

# The Peak Dwellers

By AUDREY OZANNE

*Lately Assistant Lecturer in the Department of Anglo-Saxon, University of Cambridge*

IT is remarkable how little archaeological discovery has added during the past hundred years to the Anglian material from the Peak district (FIG. 5) known to the Derbyshire antiquary, Thomas Bateman, and his colleague, Samuel Carrington. This material came largely from their own excavations in the barrows of the uplands of Derbyshire and Staffordshire and was published by Bateman in his classic *Vestiges of the Antiquities of Derbyshire* (1848) and *Ten Years Diggings in Celtic and Saxon Grave Hills* (1861). John Lucas in the 1860s excavated one or two more sites, but during the twentieth century no further Anglian mounds in the Peak proper have been investigated. Nevertheless, our knowledge of the Angles in this area may be much advanced by reconsideration of the familiar material in the light of recent discoveries elsewhere.<sup>1</sup>

Since the comprehensive résumés in the Victoria County Histories of Derbyshire (1905) and Staffordshire (1908) were made by Reginald Smith and others, we have gained several new means of dating seventh-century material. In particular Nils Åberg in his *The Anglo-Saxons in England* (Uppsala, 1926) laid a firm foundation for our studies with a chronological scheme which the breath-taking discoveries of Sutton Hoo served only to substantiate. Meanwhile T. C. Lethbridge's excavations at Burwell and Shudy Camps in Cambridgeshire and E. T. Leeds's at North Leigh and Chadlington in Oxfordshire have thrown a new light on the date and context of Faussett's great series of seventh-century cemeteries in Kent.<sup>2</sup> Even on the vexed problem of the hanging-bowls there is now some broad measure of agreement; G. Haseloff's publication of the Bekesbourne fragments is specially useful in demonstrating the existence of earlier and later types of hanging-bowl and styles of ornament within the seventh century.<sup>3</sup> Thanks mainly to R. L. S. Bruce-Mitford, we are slowly beginning to understand the vast import of Sutton Hoo for Anglo-Saxon archaeology as a whole.<sup>4</sup> D. B. Harden has distinguished the seventh-century glasses.<sup>5</sup> Vera Evison has defined a group of seventh-century shield-bosses, thus enabling us to date humble

<sup>1</sup> Thanks are due to the Trustees of the British Museum and to the Sheffield Museum for permission to publish objects in their keeping, and for photographs, and to Professor Dorothy Whitelock and Mrs. Audrey Meaney who have suggested various improvements to the text. Bateman's two books are hereafter cited as *Vestiges* and *Ten Years*.

<sup>2</sup> Lethbridge, *Recent Excavations in Anglo-Saxon Cemeteries in Cambs. and Suffolk* (Cambridge Antiq. Soc., 4to publ., n.s. III, 1931); *id.*, *A Cemetery at Shudy Camps, Cambs.* (*id.*, v, 1936); Leeds, *Oxoniensia*, v (1940), 21 ff.; *id.*, *Anglo-Saxon Art and Archaeology* (1936), ch. vi; B. Faussett, *Inventorium Sepulchrale* (1856).

<sup>3</sup> *Med. Archaeol.*, II (1958), 72 ff., with a full bibliography of earlier work.

<sup>4</sup> *Proc. Suffolk Inst. Archaeol.*, xxv (1949), 1 ff.

<sup>5</sup> *Dark-age Britain: studies presented to E. T. Leeds* (ed. D. B. Harden, 1956), 132 ff.

graves lacking in jewellery or glass.<sup>6</sup> J. N. L. Myres has identified the contemporary pottery in certain districts.<sup>7</sup> The body of relevant finds is continually being increased by excavation, as, for example, in D. M. Wilson's small but important cemetery at Melbourn (Cambs.).<sup>8</sup> The result of all this work is that one may now turn to the older publications and distinguish with some confidence between seventh-century and earlier material in all the counties of England where Anglo-Saxon cemeteries occur.

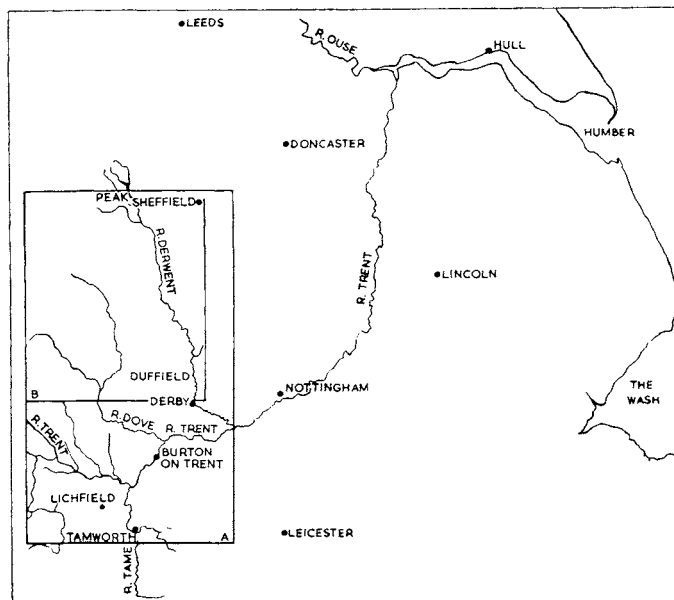

FIG. 5

SKETCH-MAP SHOWING POSITION OF THE PEAK DISTRICT

As illustrated in FIG. 6 (see inset 'A') and FIG. 7 (see inset 'B') in relation to the East Midlands of England and the Trent Basin

As far as Derbyshire and Staffordshire are concerned Margaret Fowler has recently described the relevant material, supplying new illustrations from Bateman's manuscripts in the Sheffield Museum, and has made a clear statement of the problems involved in its interpretation, with some very provocative and controversial suggestions for their solution.<sup>9</sup> The problems as she sees them are, briefly, that it is strange to find objects of Christian significance in barrows; that the contrast between the earlier pagan flat-grave interments by cremation or inhumation of the Trent basin and the obviously later barrow-inhumations of the Peak district requires explanation; that the origin of the Anglian use of barrows

<sup>6</sup> *Archaeol. Cantiana*, LXX (1957), 84 ff.

<sup>7</sup> *Archaeol. J.*, CVIII (1952), 68, 86 ff.

<sup>8</sup> *Proc. Cambridge Antiq. Soc.*, XLIX (1956), 29 ff.

<sup>9</sup> *Derbys. Archaeol. J.*, LXXIV (1954), 134 ff.

at all in this district is mysterious; that certain objects suggest Celtic connexions and an appreciable survival of Romano-British elements in the population; and finally, that there seems to be a special connexion between the Peak district and Kent, owing, it has been suggested, to the extension of the Mercian sphere of influence into south-eastern England under Wulfhere. The present paper is an attempt to solve these problems by a close attention to the dating of the finds and, even more particularly, to their distribution.

It is a commonplace that the distribution of Anglo-Saxon cemeteries broadly reflects the settlement of the population of the fifth, sixth and seventh centuries. But, if one plots individual sites on a large scale map, puzzling features emerge in certain localities where sites, more often than not seventh-century sites, are thickest on the ground in districts which it is impossible to believe were in fact the most densely inhabited areas. A good case in point is the Breckland of north-west Suffolk, where the cemeteries are much more numerous than elsewhere in East Anglia, but where one is very reluctant on three counts to admit that there was a concentration of population: first, in theory, the over-dry, sandy heathlands are fundamentally unsuitable for the support of a population supposed to have relied upon arable farming; second, they are known not to have been properly converted to arable land by enclosure and tree-planting until the nineteenth century and are described by several travellers in the seventeenth and eighteenth centuries as uninhabited and uncultivable, 'a mere African desert'; third, the record of Domesday Book reveals that this part of Suffolk supported only a sparse population of fishermen and shepherds in the eleventh century, and that, so far from being the most heavily-settled district of East Anglia, it was the least.<sup>10</sup> Since there is no known reason for the Anglian population to have shifted away from the Breckland in the centuries preceding the Norman conquest, we must conclude that the absence of intensive cultivation of the Breck has preserved much evidence of its scanty population, while ploughing has destroyed the traces left by the main bulk of the population settled elsewhere.

Precisely the same situation is met with in the Peak district, where the Carboniferous Limestone is notoriously unsuitable for anything but rough pasture, is known to have been sparsely inhabited even in relation to the forested claylands in the eleventh century, and has continued so until the present day. Agricultural difficulties set by the terrain and their gradual partial solution in modern times have been discussed recently by G. E. Fussell in his paper 'Four centuries of farming systems in Derbyshire: 1500-1900'.<sup>11</sup> Yet there is virtually no datable seventh-century material in Mercia proper except upon the Limestone (FIGS. 6 and 7).

Our first task is to show that most of the finds are in fact of this date. The descriptions which follow deal with Derbyshire and Staffordshire separately, an arrangement intended to facilitate reference to the Victoria County Histories, where a fuller account of most of the sites is to be found.

<sup>10</sup> R. R. Clarke, *In Breckland Wilds* (1937), pp. 90, 93 ff.; H. C. Darby, *The Domesday Geography of Eastern England* (1952), pp. 153 ff., especially pp. 185 ff., 201, 205 f. and figs. 38-51.

<sup>11</sup> *Derbys. Archaeol. J.*, LXXI (1951), 1 ff.

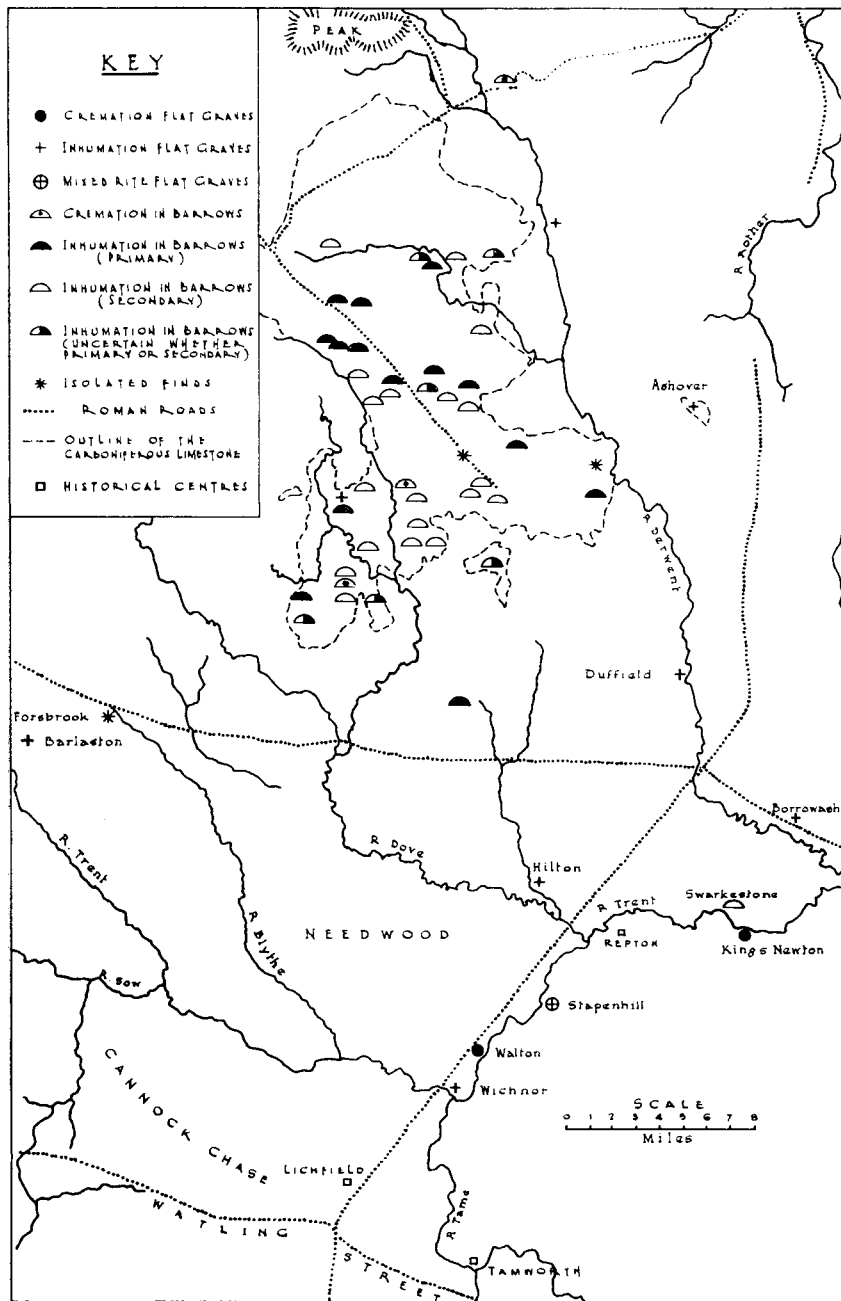

FIG. 6

DISTRIBUTION OF ANGLIAN BARROWS AND FLAT-GRAVE CEMETERIES IN THE PEAK AND ON THE TRENT (pp. 17, 35 f., 46)

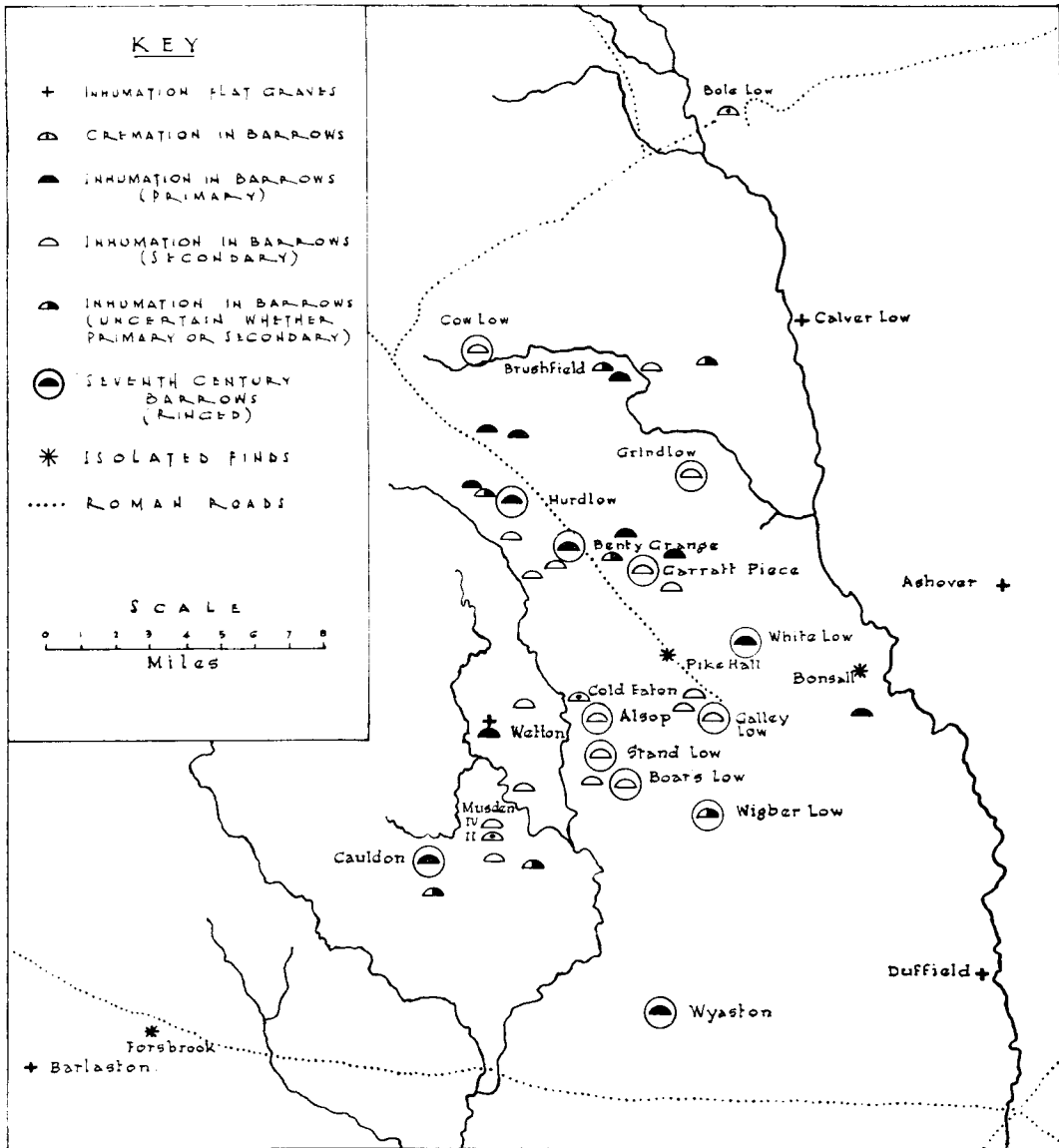

FIG. 7  
DISTRIBUTION OF ANGLIAN BARROWS IN THE PEAK (pp. 17, 35, 46)

## DERBYSHIRE

A dozen barrow-interments in the Peak district of Derbyshire may be attributed to the seventh century with some confidence.

The richest and most celebrated of these is the warrior's grave at *Benty Grange* (T. Bateman, 1848),<sup>12</sup> which contained, *inter alia*, a helmet ornamented with a Latin cross in silver on the nasal and a boar on the crest, the remains of a leather cup similarly decorated with crosses in silver, and the three escutcheons of a hanging-bowl. The straightforward interpretation of this find would seem to be that it dates from a period subsequent to the official introduction of Christianity into Mercia in 655, a conclusion borne out by a study of the style of the remnants of the escutcheons. For, while the Anglo-Saxons were avid collectors of exotic treasures when they could find them, it cannot be supposed that they were so indifferent to the importance of symbolism as to furnish a grave with two such patently Christian emblems as this helmet and cup, without meaning something by it. The same has at last been recognized in the case of the Paul and Saul spoons in the Sutton Hoo cenotaph.<sup>13</sup>

The escutcheons are represented by fragments in the Ashmolean and Sheffield Museums and by two other fragments known only from illustrations. The finds from this and the other sites are illustrated by Llewellynn Jewitt in his *Relics of Primeval Life in England* (about 1850, in the Sheffield City Museum) in water colour and to scale, a source superior to the sketches in Bateman's manuscripts.

On the fragments extant the design is a simple interlace of three legless creatures, possibly fish or serpents, grasping each other by the tail, executed in yellow enamel on a red field (FIG. 8, *a*). Françoise Henry ascribes the pieces to the seventh century on technical and stylistic grounds (the use of yellow enamel does not antedate that period) and draws attention to the similarity of the interlaced beasts with detail from the Book of Durrow.<sup>14</sup> At the same time, as she shows, there is a similarity with the animal ornament on discs without enamel from Kent,<sup>15</sup> and, one might add, more particularly with three open-work discs from Faversham having two dolphins flanking a Latin cross, another patently Christian composition (FIG. 8, *b*). Haseloff also regards the Benty Grange creatures as dolphins, and as motifs specifically of the Celtic rather than of the Germanic animal repertoire, and has shown, moreover, that Celtic influence on English ornament does not antedate Irish missionary activities beginning in about 634.<sup>16</sup> Françoise Henry was the first to suggest that hanging-bowls may have been produced in England in ecclesiastical workshops, a most satisfactory explanation of their Irish ornament and English distribution, supported by the fact that in Ireland and in England metalworking was certainly carried on within the monasteries.<sup>17</sup> The Sutton Hoo buckle illustrates the Germanic and Celtic styles of inter-

<sup>12</sup> *Ten Years*, p. 28; *Annual Report of the Sheffield City Museum*, 1955-56, p. 13.

<sup>13</sup> *Op. cit.* in note 4, pp. 30 ff.

<sup>14</sup> *J. Roy. Soc. Antiq. Ireland*, 7 ser. LXVI (1936), 235, fig. 9, f, 236.

<sup>15</sup> *Ibid.*, fig. 9, b, c.

<sup>16</sup> *Op. cit.* in note 3, p. 88.

<sup>17</sup> *Op. cit.* in note 5, pp. 71 ff.



FIG. 8

ESCUTCHEONS AND PRINTS FROM HANGING-BOWLS (pp. 20 ff.). Sc.  $\frac{3}{4}$   
*a, c, e*, Benty Grange; *b*, Faversham; *d*, Winchester; *f, g*, Middleton Moor. *c* and *e* after water-colours  
 by Ll. Jewitt

lace side by side, and was made in the mid-seventh century. Other pieces with the Celtic interlace style from Crundale and Wye Down (Kent), together with our dolphins from Benty Grange and Faversham, cannot date before 640 and are much more likely to belong to the latter half of the seventh century, while a date for Crundale in the eighth century is quite plausible. The lack of numerous parallels in metalwork from graves for such pieces and their approximation to the style of the Durrow manuscript are alike explained by the late date.

Another fragment from Benty Grange known only from illustrations (FIG. 8, *c*), is probably part of the print of the bowl. Its closest parallel is the print from the Winchester bowl (FIG. 8, *d*). A date for the latter not earlier than the middle decades of the seventh century may be argued along two independent lines: first, the style of trumpet design on the bowl's escutcheons, according to Haseloff, already shows the wiriness typical of the later seventh-century group of bowls (e.g. Bekesbourne, Whitby) and belongs to a style (e.g. Barrington, Oving, Westmorland) transitional between earlier fat patterns and the later wiry style; second, the accompanying *scramaseax* has no known parallels earlier than the second half of the seventh century, as both Lethbridge and J. D. Cowen have remarked.<sup>18</sup> The Winchester skeleton was aligned head south-south-east with the face turned to the east, so that only a quibbler would object to a Christian date on the score of orientation!

There is yet another fragment from Benty Grange known only from drawings (FIG. 8, *e*), which may be part of the frame of an escutcheon comparable to a frame from Grindlow (FIG. 9, *a*).

To sum up, the parallels quoted suggest that the Benty Grange bowl would hardly have been available for burial in a remote district of Derbyshire until the second half of the seventh century. In this context the Christian look of the helmet and cup is not surprising.

A broken hanging-bowl and one of its escutcheons (FIG. 8, *f*) were found in a grave at *Garratt Piece, Middleton Moor* (Middleton by Youlgrave)<sup>19</sup> in a barrow destroyed by a farmer in 1788. With them was associated a second enamelled object (FIG. 8, *g*), identified by Françoise Henry as the hinge of a house-shaped shrine that may be matched by a shrine from Lough Erne and is similar to the Monymusk reliquary.<sup>20</sup> It is, however, perhaps more likely to be merely another hanging-bowl attachment and in shape is not dissimilar to the ornaments immediately below the escutcheons of the largest of the Sutton Hoo hanging-bowls. A shield-boss was found also, but is not extant and no details are known of its type.

The Middleton Moor escutcheon is enamelled in red only, while the second attachment has both yellow and red, like the Benty Grange fragments. The escutcheon has a trumpet pattern of the type which Françoise Henry, together with most authorities nowadays, refers to the seventh century. In the fine lines

<sup>18</sup> Lethbridge, *A Cemetery at Study Camps, Cambs.* (Cambridge Antiq. Soc., 4to publ., n.s. v, 1936), p. 14; *Archaeol. Aeliana*, 4 ser. VIII (1931), 338.

<sup>19</sup> *Archaeologia*, IX (1789), 189; *Vestiges*, pp. 24, 105.

<sup>20</sup> *Op. cit.* in note 14, p. 234.



of the design as opposed to the bolder swelling patterns of, for example, the Greenwich escutcheon, Haseloff sees the beginnings of a development from trumpet patterns based on the triskele towards designs wherein the spirals play a more independent role, as in the Bekesbourne pieces, which are very plausibly ascribed to the latter part of the seventh century at the earliest, by analogy with those from Whitby.<sup>21</sup> His suggested sequence (based, of course, upon stylistic considerations and not proving a series of precise dates) would place the Middleton Moor escutcheon rather later than Sutton Hoo, but earlier than the Winchester bowl referred to above. A likely date for our bowl would seem to be the third quarter of the seventh century, or, at all events, not before 640.

A barrow at *Grindlow*, Overhaddon (T. Bateman, 1849)<sup>22</sup> yielded a second fragmentary hanging-bowl (FIG. 9, *a*). One escutcheon only was found, or rather part of the silver-plated bronze frame of an escutcheon of which Margaret Fowler has published a drawing after Jewitt.<sup>23</sup> A fragment from Benty Grange (FIG. 8, *e*), probably the frame of an escutcheon, has a similar decoration. The Grindlow pieces are extant in the Sheffield Museum and there is no doubt at all that they are parts of the frame of an enamel, as Bateman supposed, although he did not realize, in 1849, that it belonged to the bowl.

The rim of the vessel itself has a simple hollow moulding similar to that of the hanging-bowls from Wilton and Baginton. It is not possible to agree with Françoise Henry in dating all the examples of this simple type of bowl without a flanged rim to the sixth century, far less with Kendrick, who regarded them as Romano-British. The deduction that they are earlier than the flanged-rim bowls rests on the typology of the rims alone, and is not supported by the evidence of associated finds or stratigraphy. Were it admitted that they are earlier, it would not follow that they all belong to the sixth century. As we shall see, the Barlaston bowl is of the simple type, but there are strong reasons for regarding it as seventh-century. Simple bowls from Faversham (Kent) and Hildersham (Cambs.) belong to a group which Haseloff places 'in the first half of the seventh century and perhaps also in part of the sixth';<sup>24</sup> and the Hildersham bowl was associated with a shield-boss of seventh-century type.<sup>25</sup> There is no necessity, therefore, to regard the Grindlow bowl as specially early.

Where richer grave-goods are lacking it is sometimes possible to date men's graves by their shield-bosses. Only two are extant from the Peak district, coming from '*The Low, Alsop in the Dale*' (T. Bateman, 1845)<sup>26</sup> and *Boar's Low, Tissington* (Lucas, 1863).<sup>27</sup> The Alsop mound contained a secondary, extended male inhumation, head west, a quartz pebble in the left hand, with the metal parts

<sup>21</sup> *Op. cit.* in note 3, p. 78.

<sup>22</sup> *Ten Years*, p. 48; *Antiquity*, vi (1932), pl. i, fig. 4.

<sup>23</sup> *Op. cit.* in note 9, p. 143 and fig. 6. Margaret Fowler appears not to agree with Bateman that the object is the frame for an enamel and compares its ornament with that of a Romano-British bracelet from Castern (below p. 50). The parallel is not significant.

<sup>24</sup> *Op. cit.* in note 3, p. 73 f.

<sup>25</sup> *Proc. Cambridge Antiq. Soc.*, XLV (1952), 44 ff.

<sup>26</sup> *Vestiges*, p. 67.

<sup>27</sup> *Reliquary*, v (1864-5), 165; *op. cit.* in note 9, p. 149; Ll. Jewitt, *Grave Mounds and their Contents* (1870), pp. 236, 247; *id.*, *Half-hours with some English Antiquities* (1884), fig. 213.

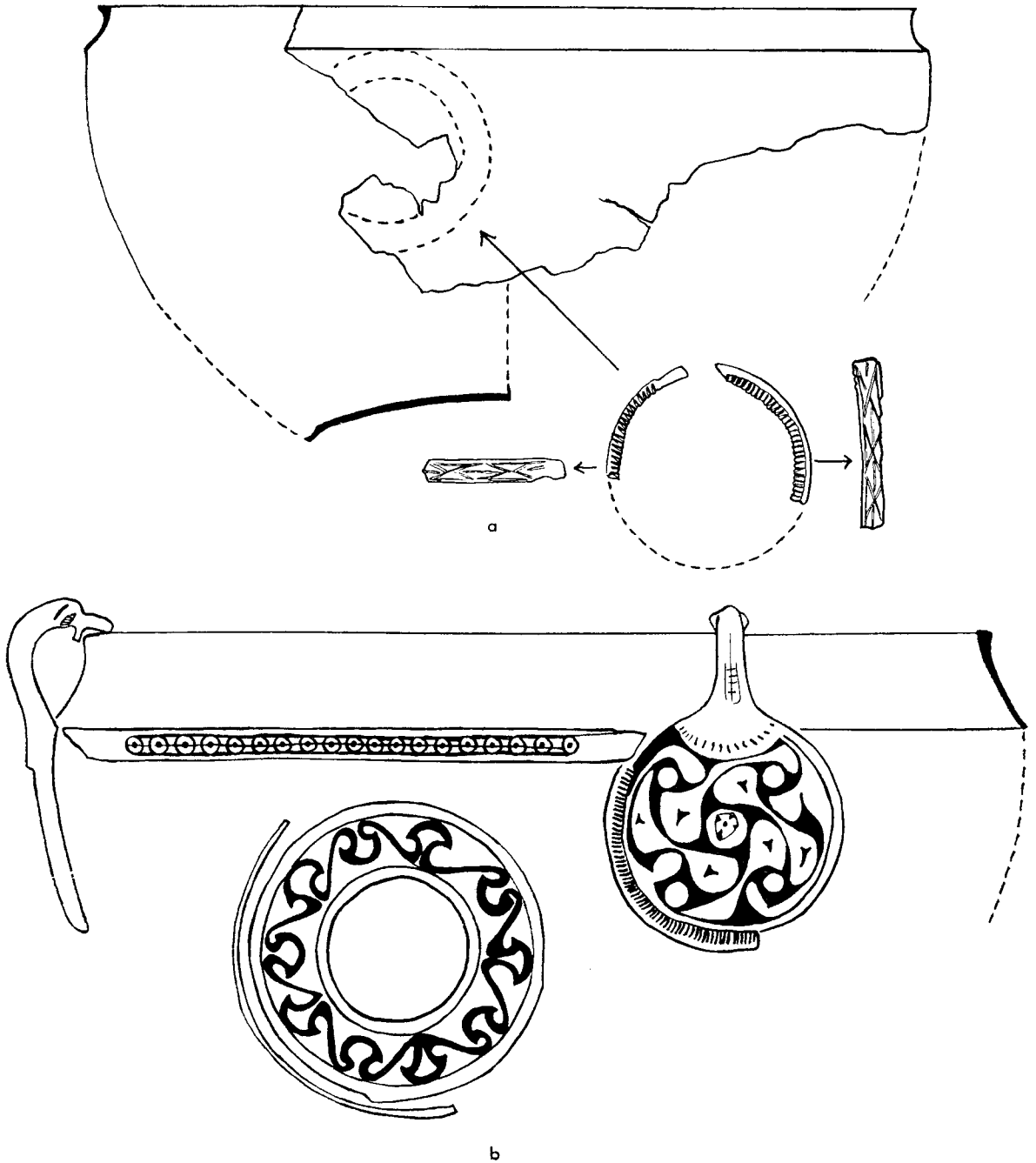

b

FIG. 9

FRAGMENTARY BRONZE HANGING-BOWLS. Sc.  $\frac{2}{3}$   
*a*, Grindlow, Derbys. (p. 23); *b*, Barlaston, Staffs. (p. 41)

of a shield including boss, rivets and hand-grip (FIG. 10, *a*). At the end of the pin of one rivet may still be seen a small bronze washer. The profile of the boss and shape of grip are typical of seventh-century shield-bosses at Holborough (Kent), Taplow (Bucks.), Holywell Row (Suff.) and Melton Mowbray (Leics.), and at other sites listed by Vera Evison, who was the first to distinguish the type.<sup>28</sup>

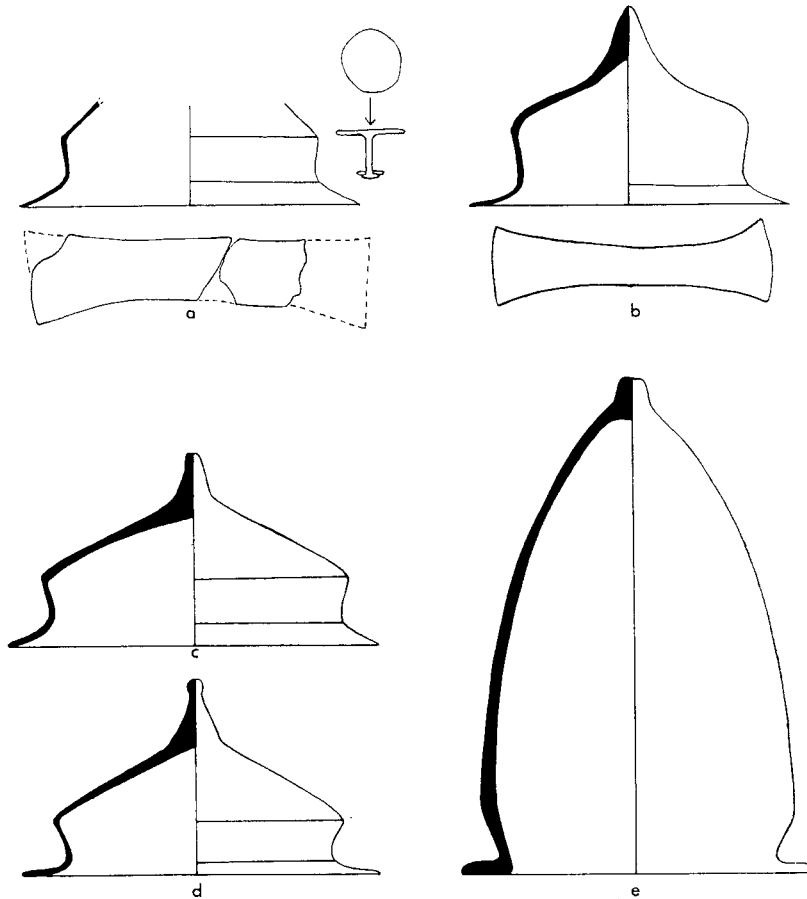

FIG. 10  
IRON SHIELD-BOSSSES FROM DERBYSHIRE (pp. 23, 25). Sc.  $\frac{1}{3}$   
*a*, Alsop; *b-d*, Hilton; *e*, Tissington

One occurs also nearer to hand in the Trent valley at Hilton, Derbyshire (A. L. Armstrong, 1946, hitherto unpublished; FIG. 10, *b*), together with bosses of the earlier carinated type (FIG. 10, *c*, *d*). Boar's Low, Tissington, contained fragments of bone in a secondary context, complete with a fine sword in a leather sheath, with silver mounts and chape, a spear-head and a tall boss of the 'sugar-loaf' type (FIG. 10, *e*). Similar bosses are best known from Kent, as for example at Sibertswold, and, if continental parallels are any guide, are a later type than that of Alsop, likely to have continued even into the eighth century. They

<sup>28</sup> *Op. cit.* in note 6, p. 96.

should be regarded as a late, rather than as a purely Kentish type, and are known elsewhere within the Mercian territory, as, for example, at Oxtou (Notts.).

Four of the five graves mentioned so far have been those of men. The sex of the skeleton at Grindlow is not known. Contemporary women's graves, one of them with a Christian ornament as specific as anything at Benty Grange, are not far to seek. Our next site, *White Low*, near Winster,<sup>29</sup> was destroyed by labourers as early as 1765, at the time of the enclosures. So far as one can tell now, the Anglian finds seem to have been in a primary context. They comprised a gold filigree pendant cross, a filigree and garnet disc and a number of objects now lost, including two pots, two glasses, beads, a silver bracelet 'studded with human heads', 'figures of animals, etc. which were affixed by rivets' and the bronze fittings of a wooden box which had contained them. Harden suggests that the glasses may have been pouch-bottles, a form which he assigns to the seventh century.<sup>30</sup>

The cross (FIG. 11, *a* and PL. IV, *E*) is made up of a solid gold plate with a central setting containing a single faceted garnet, decorated with filigree in a scroll-pattern and bordered by beaded gold wire; near the loop is a transverse line of plait filigree. Pendant equal-armed crosses are known also from Wilton (Norf.), Stanton, near Ixworth (Suff.), St. Cuthbert's grave at Durham, Desborough (Northants.) and Kingston (Kent), and a Latin cross from Chartham Down (Kent), all of them seventh-century. The White Low cross is not especially like any of these and is the only one decorated with filigree, except for the plait filigree on the loop of the Wilton cross. Pendant discs decorated with equal-armed crosses in filigree are not uncommon in Kent, as for example at Kingston, Sibertswold and Breach Down, while three at Milton-next-Sittingbourne are associated with *sceattas* probably not earlier than the last quarter of the seventh century.<sup>31</sup> The filigree of these three Milton discs is more sophisticated than that on the White Low cross. St. Cuthbert's grave-furniture alone is sufficient to inform us that in the second half of the seventh century it was not thought un-Christian to deposit important jewellery with the dead. White Low and the contemporary Kentish graves of Faussett must be accepted as Christian, not as the graves of pagans who had happened to acquire objects of Christian significance.

The White Low disc (FIG. 11, *b* and PL. IV, *D*) lacks means of attachment; it consists of a gilt silver plate with silver backing, the front decorated with a zone of garnet cloisonné round a central stone (missing) with two exterior zones of filigree ornament and four cabochon garnets. The filigree, in gold, includes cable, plait, and S-shaped motifs with a beaded wire border; the overall pattern is cruciform and perhaps significantly so. The arrangement of the cloisons in a close-set, step-cut zone mounted over hatched gold foil and the S-motif of the filigree may be taken as dating the piece in the seventh century.<sup>32</sup> Similar jewels are well known and well dated in Kent, but our disc is not precisely matched

<sup>29</sup> *Archaeologia*, III (1775), 274; *Vestiges*, p. 19; *op. cit.* in note 9, p. 148.

<sup>30</sup> *Op. cit.* in note 5, p. 166.

<sup>31</sup> *Proc. Suffolk Inst. Archaeol.*, xxxvi (1952), 16.

<sup>32</sup> E. T. Leeds, *Anglo-Saxon Art and Archaeology*, p. 105; N. Åberg, *The Anglo-Saxons in England*, pp. 109 ff.



FIG. 11

GOLD AND SILVER JEWELLERY AND GLASS BEAD FROM DERBYSHIRE (pp. 26 ff). Sc.  $\frac{1}{4}$   
*a, b*, White Low; *c, d, e*, Cow Low; *f*, Galley Low. Some of the beads and 'bullae' of *e* after water-colours  
 by Ll. Jewitt

by any of the individual Kentish disc-brooches and pendants. No doubt the Mercians, like the East Angles and the Northumbrians, may be supposed to have had their own workshops.<sup>33</sup> No exact parallels to the petal-shaped garnets of White Low are known. For complexity and sophisticated finish their cutting and setting bears no comparison with the petal or flame-shaped cloisons of the Sutton Hoo scabbard-bosses.<sup>34</sup> Nevertheless our disc probably belongs to the same chronological phase as the Sutton Hoo bosses and other jewellery with cloisons cut in more or less technically difficult curvilinear shapes, such as, for example, the fish-scales of the buckle from Gilton (Kent)<sup>35</sup> and the wreath of the pendant (PL. IV, c) from Bacton (Norf.). This period saw the apogee of the jewel-cutters' art and belongs, if Sutton Hoo is any guide, to the middle decades of the seventh century.

The placing of many of the objects in this woman's grave in a bronze-bound wooden box is entirely in keeping with the practices observed in seventh-century 'Christian Saxon' graves in Kent and Cambridgeshire.

We turn next to six women's graves in barrows, all of which contain artefacts typical of Lethbridge's 'Christian Saxon' assemblages so well known in Cambridgeshire and at Faussett's sites in Kent.

*Cow Low*, near Buxton (T. Bateman, 1846),<sup>36</sup> a prehistoric barrow, yielded the teeth of an Anglian secondary interment, presumably female, associated with a pair of gold pins, linked by a chain, and with the remains of a padlocked bronze-bound wooden box containing a necklace, a glass palm-cup, a decayed bone comb, a dog or fox tooth, and fragmentary iron and ivory objects.

The pin-suite is of solid gold with inset flat garnets in the pin-heads, bordered with beaded gold wire (FIG. 11, c). Pin-suites in gold, silver or bronze are known from Faversham, Lympe, Breach Down and Chartham Down (Kent), Shudy Camps (Cambs.), Little Hampton, near Evesham (Worcs.), Winnall (Hants), Long Wittenham (Berks.), and Roundway Down (Wilts.), the last-named site having gold pins inset with garnets almost identical with those of Cow Low.<sup>37</sup> Another very close parallel is seen in two silver pins without chains from Chartham Down and Sibertswold (Kent), both of which have inset garnets in the heads.<sup>38</sup> Near the pin-suite was found a blue glass bead (FIG. 11, d) which had a marvered wavy-line pattern, of a type common in seventh-century graves, probably a toggle for the belt.<sup>39</sup>

Of the contents of the box, the glass has been assigned to the seventh century by Harden, using typological criteria independent of the associated finds.<sup>40</sup>

<sup>33</sup> For the Northumbrians see R. L. S. Bruce-Mitford in *The Relics of St. Cuthbert* (ed. C. F. Battiscombe, 1956), p. 322.

<sup>34</sup> *Op. cit.* in note 4, pp. 32 ff., pls. ii, b, xi.

<sup>35</sup> Åberg, *op. cit.* in note 32, fig. 224.

<sup>36</sup> *Vestiges*, pp. 91 ff.; *op. cit.* in note 9, p. 147.

<sup>37</sup> *British Museum Guide to Anglo-Saxon Antiquities* (1923), p. 43 f.; Leeds, *op. cit.* in note 32, pp. 108 ff., pl. xxix, a; Lethbridge, *op. cit.* in note 18, p. 25; *V. C. H. Worcs.*, 1, 229. Thanks are due to Mrs. A. Meaney for permission to refer to unpublished finds from her excavation at Winnall.

<sup>38</sup> Faussett, *op. cit.* in note 2, pl. xii, 18, 20.

<sup>39</sup> Cf. Lethbridge, *Recent Excavations in Anglo-Saxon Cemeteries in Cambs. and Suffolk* (Cambridge Antiq. Soc., 4to publ., n.s. III, 1931), p. 76.

<sup>40</sup> *Op. cit.* in note 5, pp. 162, 165, pl. xviii, o.

The necklace as found consisted of eleven beads and pendants (FIG. 11, *e*). There were two biconical beads of 'electrum' (not extant), eight convex silver 'bullae' (four extant), and a pear-shaped silver pendant inset with a blue glass bead with white spirals. Similar biconical or barrel-shaped beads of gold or silver wire are known in seventh-century contexts at Shudy Camps (Cambs.), Desborough (Northants.), Newton Lodge, Clifton-upon-Dunsmore (Warwicks.) and Roundway Down.<sup>41</sup> The 'bullae' have an even wider distribution, again in seventh-century contexts, as at Sibertswold and Kingston (Kent), Kempston (Beds.), Burwell, Shudy Camps, Desborough, Newton Lodge, Camerton (Som.), and Uncleby (Yorks.).<sup>42</sup> The pear-shaped pendant is well matched at Melbourn (Cambs.), grave 11, in silver, and at Sibertswold, grave 172, in gold, both the parallels however having glass settings inset with millefiori which Cow Low has not.<sup>43</sup> The toothed border of the Cow Low pendant is matched by a pear-shaped gold and garnet pendant from Chartham Down and a similar pendant from Barfriston (Kent).<sup>44</sup>

I have to thank Mr. D. M. Wilson for bringing to my notice the unpublished finds in the British Museum from *Wigber Low* (Lucas, 1869).<sup>45</sup> Two individuals are represented, presumably, by a spear-head and a woman's jewellery (PL. III, A), the latter comprising two silver pins, two beads threaded on contracting rings of silver wire, a boar's tusk mounted in gold, a fragmentary gold disc-pendant, a silver penannular brooch and part of a toggle bead of very dark purple glass.

The heads of the pins are cruciform, with cabochon garnets in the centre, surrounded by four flat garnets mounted over gold foil in gold cloisonné settings, with a double border of beaded gold wire. Although they lack a connecting chain they are reminiscent of the jewelled pin-suites of Cow Low and Roundway Down.

Contracting wire rings or 'knot-rings' in silver, or less frequently bronze, were a common type of feminine ornament in the 'Christian Saxon' period. They were worn at the neck and not as ear-rings.<sup>46</sup> They are known from Kent (Chartham Down, Kingston, Barfriston, Sibertswold), Hampshire (Horndean, Winnall), Berkshire (Long Wittenham), Oxfordshire (North Leigh), Somerset (Camerton), Bedfordshire (Leighton Buzzard), Cambridgeshire (Burwell, Shudy Camps, Melbourn), Suffolk (Ipswich, Holywell Row, Warren Hill, Mildenhall), Yorkshire (Uncleby, Garton Slack),<sup>47</sup> and Lincolnshire (Castle Bytham).<sup>48</sup>

<sup>41</sup> Lethbridge, *op. cit.* in note 18, p. 5; *Archaeologia*, xlv (1880), pl. xxxix; *V.C.H. Warwicks.*, 1, 253; Leeds, *op. cit.* in note 32, p. 109, fig. 23, *b*.

<sup>42</sup> Faussett, *op. cit.* in note 2, pp. 91, fig. 1, 122; Lethbridge, *op. cit.* in note 39, p. 70 and *op. cit.* in note 18, p. 8; *Archaeologia*, xlv (1880), pl. xxxix; *V.C.H. Warwicks.*, 1, 253; Leeds, *op. cit.* in note 32, pl. xxxi, grave 94 B, pl. xxvii, grave 62.

<sup>43</sup> *Op. cit.* in note 8, p. 34; Faussett, *op. cit.* in note 2, pl. iv, 8, 9.

<sup>44</sup> Leeds, *op. cit.* in note 32, pl. xxix, *a*; Faussett, *op. cit.* in note 2, pl. iv, 5.

<sup>45</sup> B. M. Acc. no. 1873. 6-2. 95.

<sup>46</sup> *Op. cit.* in note 39, pp. 52, 70.

<sup>47</sup> Faussett, *op. cit.* in note 2, pl. vii; *Papers and Proc. Hants. Field Club*, xix (1957), 135 and fig. 15; Leeds, *op. cit.* in note 32, p. 110, pl. xxvii, grave 62, pl. xxviii, pl. xxix, *a*, pl. xxxi; *Oxoniensia*, v (1940), 22 f.; Lethbridge, *op. cit.* in note 39, pp. 2, 9, 52, 70 and *op. cit.* in note 18, p. 5; *op. cit.* in note 8, p. 34; *Proc. Suffolk Inst. Archaeol.*, vi (1888), 63, 66; *id.*, xiii (1909), 14, 19 (graves 85, 154, 157).

<sup>48</sup> *Archaeol. J.*, x (1853), 81. In the University Museum of Archaeology and Ethnology, Cambridge.

Perforated animal teeth also are a not uncommon feature of this, as of earlier periods. Boar's tusks occurred at Purwell Farm, Cassington (Oxon.), and at Camerton, beaver's teeth at Burwell, threaded on a bronze ring, and at Castle Bytham in a bronze setting.<sup>49</sup> All four are seventh-century sites.

The gold disc-pendant had a quatrefoil design of beaded gold wire, and once held a central garnet. It is a simplified version of a well-known seventh-century type, and is not unlike a pendant from Uncleby.<sup>50</sup>

The penannular brooch (FIG. 12, *f*) is round in section and decorated with three groups of transverse lines; the terminals were clearly ornamental but are unfortunately broken. Good parallels for the ring are found in penannular brooches with zoomorphic terminals recently published by H. N. Savory from Icklingham (Suff.) and Woodeaton (Oxon.) from a Romano-British context.<sup>51</sup> The type is of Celtic, ultimately of Romano-British, origin. It is interesting to observe that its English-made derivatives are more at home in English contexts in the seventh century, notably at Uncleby (Yorks.), than in the fifth and sixth centuries. The Wigber Low brooch, possibly of Celtic manufacture, must also, of course, be seventh-century in date, from its context.

*Galley Low* or *Callidge Low*, Brassington (T. Bateman, 1843),<sup>52</sup> yielded a disturbed secondary inhumation, presumably female, with, *inter alia*, two toggle-beads and the richest of the Derbyshire ornaments, a gold necklace of fourteen pieces—one biconical bead, eleven garnet pendants soldered on to biconical beads and two 'bullae' (FIG. 11, *f*). Parallels for the biconical beads and 'bullae' have been discussed for Cow Low. Both the Galley Low 'bullae' are bordered with beaded gold wire and have cylindrical rilled loops which match well with the soldered wire corrugations of the biconical beads. The pendants range from drop-shaped to triangular and oval and contain cabochon garnets, except for the two oval garnets in the centre, each of which has a single facet. Similar pendants are known from Westbere, Kingston, Sibertswold, Barfriston, Chartham and Stowting (Kent), Standlake (Oxon.), Roundway Down (Wilts.), Newton Lodge (Warwicks.), Kempston (Beds.), Desborough (Northants.) and Uncleby (Yorks.), all with garnets, and at Garton Slack (Yorks.) with a jet bead inset.<sup>53</sup>

The barrow at *Wyaston* (Carrington, 1852)<sup>54</sup> preserved only the teeth of a primary inhumation, presumably female, with a more ordinary Anglo-Saxon necklace of twenty-seven amber and multi-coloured glass beads, two silver 'ear-rings' (these look from sketches more like small staples), a silver 'finger-ring' (FIG. 12, *c*), and an annular metal object (FIG. 12, *d*), probably silver. The 'finger-ring' (not extant) was an elaborate version of the silver wire 'knot-

<sup>49</sup> *Oxonienisia*, vii (1942), 65, fig. 15; *Proc. Somerset Archaeol. and Nat. Hist. Soc.*, lxxix (1934), 45; *op. cit.* in note 39, p. 47. For Castle Bytham see the preceding note.

<sup>50</sup> Leeds, *op. cit.* in note 32, pl. xxvii, 31 (top right).

<sup>51</sup> *Op. cit.* in note 5, pl. v, *c*, *e*.

<sup>52</sup> *Vestiges*, p. 37; *op. cit.* in note 9, p. 146.

<sup>53</sup> *Antiq. J.*, xxvi (1946), pl. ii; Faussett, *op. cit.* in note 2, pls. iv and vii, 8; *Proc. Soc. Antiq. London*, 2 ser. II (1861-4), 442; Leeds, *op. cit.* in note 32, fig. 23, *b*, pl. xxix, *a*; *V.C.H. Warwicks.*, I, 253; *V.C.H. Bedfords.*, I, 181 and fig. 8; *Archaeologia*, xlv (1880), pl. xxxix; *Proc. Soc. Antiq. London*, 2 ser. xxiv (1911-12), 150 (grave 13); J. R. Mortimer, *Forty Years Researches in British and Saxon Burial Mounds of East Yorkshire* (1905), p. 251, pl. lxxxvii, fig. 672.

<sup>54</sup> *Ten Years*, p. 188; *op. cit.* in note 9, p. 150, fig. 10.



ring' of the type discussed above, and, unlike the beads, is a diagnostic seventh-century type; very similar rings are known from Kingston (Kent), grave 250, in bronze, and Holywell Row (Suff.), grave 12, in silver.<sup>55</sup> The annular object (not extant) was ribbed on the front and flat on the back and was not necessarily an annular brooch; ribbed rings occur as parts of the fittings of hanging-bowls; Jewitt's drawing does not suffice to identify the purpose of this one.

Cylindrical thread-boxes are yet another, more utilitarian, item of the 'Christian Saxon' assemblage. Examples may be cited from at least nine counties, Kent (Kingston, Sibertswold, Chartham), Wiltshire (Cherhill Barrow 10), Oxfordshire (North Leigh, Standlake), Bedfordshire (Kempston), Cambridgeshire (Burwell), Northamptonshire (Cransley), Lincolnshire (Barton-on-Humber), Derbyshire (Stand Low and Hurdlow) and Yorkshire (Uncleby, Garton Slack, Painsthorpe Wold and Kirby Underdale).

At *Stand Low*, near New Inns (T. Bateman, 1845),<sup>56</sup> the Anglian interment, again represented by teeth only but presumably female, was probably primary, although small prehistoric flint tools had been scraped into the mound. In addition to the thread-box there were two iron knives, two bronze rings, part of a glass vessel, eleven glass beads, a biconical bead of silver wire, a moulded silver pin and iron fragments which, by analogy with Burwell, were probably the chain of a chatelaine. The thread-box and the bronze rings (FIG. 12, *a, b*), which are not a pair, were found together in a position corresponding to the left side of the body, and the rings are therefore not annular brooches but 'key-rings' or component parts of the chatelaine-complex such as are well-known from Lethbridge's meticulous observations at Holywell Row, Burwell and Shudy Camps.<sup>57</sup> Three of the glass beads look earlier, but the thread-box, chatelaine and biconical bead suffice to ascribe the site to the seventh century. Moulded silver pins are frequent in the Kentish and Cambridgeshire sites in the seventh century, but rare in earlier contexts.

The barrow at *Hurdlow* (T. Bateman, 1849)<sup>58</sup> contained a primary female inhumation in the extended position, with its head to the west. There was an iron knife, and, with the thread-box, two bronze needles and the remains of thread, the remains of an iron chatelaine-chain with a silver-plated bronze attachment (FIG. 12, *m*), and an iron key-shaped object terminating in a double hook. This last is, again, part of what might be termed the chatelaine-complex. It is interesting to observe that the pagan Anglian 'girdle-hangers' in bronze are superseded throughout the country in the seventh century by these plain iron hooks; good examples were found at Burwell, Shudy Camps, Ipswich and Petersfinger (Wilts.).

The parallels cited for Cow Low, Wigber Low, Galley Low, Wyaston, Stand Low and Hurdlow are chosen not as complete lists for the types concerned, but to show that the material culture they represent obtained not only in Kent and in Cambridgeshire but throughout the country, so far as we know. The

<sup>55</sup> Faussett, *op. cit.* in note 2, pl. xi, 13; *op. cit.* in note 39, p. 12.

<sup>56</sup> *Vestiges*, p. 74; *op. cit.* in note 9, p. 148.

<sup>57</sup> *Op. cit.* in note 39, pp. 62, 86.

<sup>58</sup> *Ten Tears*, p. 52.

two names proposed for this culture, 'Kentish' and 'Christian Saxon' are neither of them entirely satisfactory, since, if the new fashions originated in Kent, they are not restricted to that county, and, although they became general during the course of the seventh century, one cannot show that they bear any precise relation to contemporary changes in religion. It is clear that the dead continued to be buried in their clothes, as in the fifth and sixth centuries; it is the design and technique of the jewellery only which has changed. The point within the seventh century at which this change took place is uncertain. However, as Lethbridge and Leeds have often demonstrated, the new fashions were in full swing after the conversion from paganism, and it is probably correct as well as convenient to call them Christian Anglo-Saxon.

The finds at Roundway Down (Wilts.) and Desborough (Northants.) are particularly instructive for dating. Roundway produced three of the leading types together, a pin-suite, seven gold pendants set with garnets and six biconical beads of gold wire. The central ornament of the pin-suite is of glass set in gold and 'engraved' with a cruciform pattern. While it is somewhat reminiscent of the Sutton Hoo scabbard-bosses, which also have a cruciform design,<sup>59</sup> it is more closely matched in setting, design and technique by some of the glass studs of the Ardagh chalice,<sup>60</sup> and even more closely by the glass stud on the Moylough belt in the Dublin Museum.<sup>61</sup> The so-called engraved pattern is left by a metal grid which has come off. In view of the date of the Irish pieces, a date in the eighth rather than the seventh century for Roundway is possible. The Desborough cemetery yielded a complete gold necklace of seventeen biconical beads, two cylindrical beads, nine 'bullae' and eight garnet pendants, from the centre of which hung a gold cross. This jewellery must have been made in the workshops of a Christian society, and, contrary to what is sometimes suggested, it more likely than not indicated the religion of the individuals who wore it. The humbler thread-boxes, too, which are a notable part of the seventh-century assemblage, have twice been found decorated with equal-armed crosses, at North Leigh (Oxon.) and at Cransley (Northants.), and they have been found in a cemetery near the Saxon church of St. Peter, Barton-on-Humber (Lincs.).<sup>62</sup> Since the Roundway Down and Desborough finds are from Wessex and Middle Anglia respectively, and since these districts were not among the first to be converted to Christianity, their jewellery must be assigned to the latter half of the seventh century or later. By analogy, our six Derbyshire graves are of the same period, and Christian.

For the culture as a whole, Lethbridge has suggested the date 650-800.<sup>63</sup> Its prolongation well into the eighth century would be in accordance with the facts that it is so much characterized by techniques different from those of Sutton Hoo and that representative finds are now becoming so numerous as to show the fashions to have been long-lived.

<sup>59</sup> *Op. cit.* in note 4, pl. xi.

<sup>60</sup> M. and L. de Paor, *Early Christian Ireland* (1960), pl. 26.

<sup>61</sup> *Op. cit.* in note 5, pl. ix, a.

<sup>62</sup> *Oxoniensia*, v (1940), 22, pl. vi, D; *Proc. Soc. Antiq. London*, 2 ser. ix (1881-3), 94; *V.C.H. Northants.* 1, 240; *Hull Museum Publications*, no. 208 (1940), pp. 257 ff.

<sup>63</sup> *Op. cit.* in note 5, p. 112.

The suggestion that cultural connexions between Mercia and Kent were increased through Wulfhere's apparent control of southern England does not explain why these connexions should be reflected in the Peakland in particular, and pending a detailed study of the situation in Middle Anglia and elsewhere, it would be a great mistake to suppose that this Kentish or 'Christian Saxon' material of the Peak is proof of a closer connexion with Kent than could be demonstrated for many other districts.

I regard it as certain that the barrows named belong to the seventh century, or later. Their assignment to a period not before 650 depends upon the view taken that these particular escutcheons and the ornaments of Christian significance are unlikely to antedate the conversion in about 655. Bede tells us that Penda did not forbid Christianity to the Mercians during his life-time.<sup>64</sup> Thus it might be suggested that objects of Christian significance reached Mercia in Penda's life-time through his alliance with Cadwallon. This does not seem likely, since the mission to the Middle Angles was not begun until two years before Penda's death, and his tolerance of Christians seems to relate to the same period; and second, the jewellery concerned is of a common type in eastern England, much of it likely to date from the later rather than from the middle of the seventh century, as has been shown. Furthermore, classes of object belonging to the earlier seventh century, such as late cruciform and square-headed fibulae and ornaments decorated in Haseloff's dense interlace style, are not met with in any of these barrows or elsewhere in the Peak district.

The accounts of the twelve excavations so far enumerated specify the orientation of the skeletons in three instances only, at Middleton Moor, Alsop and Hurdlow, all three of which had the east-west orientation, another minor indication that we are studying the remains of a Christian population.

The enquiry whether this population was building new barrows as well as using old ones is not very profitable. Thomas Bateman at his own excavations observed the distinction between primary and secondary interments and noted where possible the orientation and position of the skeletons: from Thomas's accounts, it would seem that his father, William, and Carrington did not observe such trivialities. It appears that the Anglian finds at Middleton Moor, Grindlow, Alsop, Boar's Low, Cow Low and Galley Low were secondary intrusions. The Benty Grange interment was primary in the only barrow known to have been ditched, the excavation of the other sites not being such as to have determined the presence or absence of a ditch. The accounts read as though White Low, Wyaston, Hurdlow and Stand Low were primary burials also, although it would be unwise to rely upon the fact. Bateman's first account of the Middleton Moor barrow destroyed in 1788 describes a skeleton in the centre of the barrow on the old ground surface ('upon the level of the ground') leading one to suppose this to have been primary; but, after re-excavation by William Bateman in 1826 and Thomas Bateman in 1847, the latter decided that it must have been secondary, because he found potsherds and prehistoric bone and flint tools in the mound. Since it is a commonplace of prehistoric archaeology that small artefacts of

<sup>64</sup> *Historia Ecclesiastica*, bk. III, ch. 21.

earlier periods may be scraped up and incorporated in barrow material (as, for example, at Stand Low, p. 31), these second thoughts were perhaps wrong. It is, therefore, not possible to decide finally whether the Middleton Moor interment was in a primary or secondary context in its barrow, and the same doubt extends to some of the others.

Bateman observed a distinction between prehistoric barrows having carefully constructed stone cairns within and the Anglian barrows, composed of earth only, and, he believed, of specially tempered earth intended to disintegrate the skeletons. This was not the first time the point had been noticed, since the very labourers who destroyed White Low in 1765 regarded the mound as singular because it contained no stones.<sup>65</sup> (One gathers that they were experienced!) It is worth noting that in the case of four of the five supposed primary burials only teeth or hair were preserved. The preservation of the secondary interments received less notice but seems to have been rather better, except where the bones were disturbed, although Cow Low also yielded nothing of the skeleton but the teeth.

Other barrows, in which specifically seventh-century material is lacking, are certainly Anglian. They include one at *Brushfield*, near Taddington (opened by a farmer in 1825),<sup>66</sup> which produced a long two-edged sword, two knives, an iron buckle and shield-boss. Although the other objects are preserved in Bateman's collection at Sheffield, the boss, which might have afforded a date, never came into Bateman's possession and is lost.<sup>67</sup> In a second barrow on the same farm, *Lapwing Hill*, Brushfield (T. Bateman, 1850),<sup>68</sup> was found a similar grave-group of sword, two spear-heads and knife with a primary extended male inhumation, its head to the west. The sword was enclosed in the remains of an ornamented leather sheath. Body and weapons had been contained in or on a wooden contraption fitted with heavy iron loops and staples more complex than would have been necessary for an ordinary coffin.

Several more finds of iron spear-heads and knives from barrows in Derbyshire suggest there was a larger number of Anglian graves in the Peak than can now be accurately ascertained. They are listed in the Table (p. 42 f.). In this group of graves the orientation of the skeletons was observed in only three instances, where again it was in the Christian manner, head to the west.

The only probable Anglian flat-grave cemeteries in the Peak district likewise afford no datable material. They are at *Calver Low* (T. Bateman, 1860)<sup>69</sup> and at *Overton Hall, near Ashover* (C. Kerry, 1887),<sup>70</sup> each site yielding five extended skeletons, all but one with the Christian orientation. Calver Low produced an Anglo-Saxon knife and sherd, Overton Hall had no grave-goods. Both sites, of course, might originally have had mounds. In addition, isolated finds in the

<sup>65</sup> *Archaeologia*, III (1775), 274.

<sup>66</sup> *Vestiges*, p. 27; *op. cit.* in note 9, p. 150.

<sup>67</sup> It is difficult to understand why it should have been suggested (*op. cit.* in note 9, p. 150) that this boss is the one illustrated by Jewitt, *Half-hours with some English Antiquities*, fig. 213, when Jewitt's text states that his figure illustrates the Tissington boss.

<sup>68</sup> *Ten Years*, p. 68; *op. cit.* in note 9, p. 150.

<sup>69</sup> *Ten Years*, p. 107.

<sup>70</sup> *Reliquary*, 2 ser. I (1887), 111; *V.C.H. Derbyshire*, I, 266.

Bateman collection include single Anglo-Saxon beads from twelve surface sites in Derbyshire.<sup>71</sup>

The study of the distribution and grouping of the Anglian barrows is handicapped by the fact that Bateman is not always able to give the precise site of barrows excavated before his time, e.g. Brushfield (1825), and, on rare occasions, falls below his usual standard by being vague about his own sites, as in the case of the barrows he opened in 1849, immediately after the Hurdlow excavation, 'on the hills rather nearer Buxton'.<sup>72</sup> On the whole, there is little positive evidence for the use of groups of barrows by the Angles in Derbyshire. This is probably due to the absence of diagnostic grave-goods from disturbed secondary inhumations in very many barrows and to the lack of systematic excavation. The only certain sites likely to have been closely adjacent are Brushfield (1825) and Slipper Low on the same farm near Taddington.

The continued or revived importance of the Roman road between Derby and Buxton is illustrated by the construction of new barrows and the reuse of prehistoric barrows along its line (FIG. 7). Benty Grange is close to the road, Hurdlow on the hills flanking it. Galley Low or Callidge Low near Brassington must have been near it, as also was the Garratt Piece, Middleton Moor, barrow. In the later seventh century a considerable amount of silver was in demand in England for jewellery and, towards the end, for coins. The expansion of the Anglian population in the argentiferous and lead-bearing districts of the Peak is perhaps concerned with this demand, and the comparatively rich equipment of a few of these graves may be due to the lead industry and trade. But, contrary to what is often supposed, the material culture is not a rich one. Graves are datable in so far as they are rich, and we have to deal here with only a dozen individuals in Derbyshire and two or three in Staffordshire with datable grave-goods. Most graves fail even to yield the belt-buckles so useful elsewhere for dating purposes. In considering the richness or otherwise of the group as a whole one must remember the seventh-century cemeteries excavated by Faussett and Lethbridge where single sites yield tens and hundreds of datable graves (as well as numerous ones without grave-goods at all).

The barrows occur in a remarkably compact group (FIG. 6), virtually restricted to the Carboniferous Limestone of the Peak, but avoiding the rigours of the High Peak. The flat graves at Overton Hall, Ashover, are on an inlier of the same formation. It is this distribution which may be held to account for the anomaly which many have seen in the presence of barrow-interments of a Christian character at a comparatively late date. The area in question is marginal land and has always been more suitable for pastoral than for agricultural farming, with the result that barrows had not been ploughed away. Careful attention to Bateman's text reveals that many mounds were first threatened by farmers at the time of the enclosures. Circumstances of the discovery of the whole group differ markedly from the situation in areas of primary settlement, as for example

<sup>71</sup> *Catalogue of the Bateman Collection of Antiquities in the Sheffield Public Museum* (1899), p. 227 f., J 93. 723-734.

<sup>72</sup> *Ten Years*, p. 54.

in the middle Trent area, where sixth-century Anglian cemeteries were discovered by accident in the nineteenth century through conversion of land *from* arable to other purposes, such as the laying of railways and the digging of clay-pits. The contrast, too, between soils suitable for agricultural purposes and marginal land is likely to have been much more marked in the Anglo-Saxon period than it is at the present day, owing to human interference as a soil-forming factor.

The Anglian Peak-dwellers, then, were living on marginal land at some distance from the known political and ecclesiastical centres of Mercia at Tamworth, Lichfield and Repton, and separated from those centres by belts of Triassic sandstones and marls supporting dense wood.<sup>73</sup> Although there is so little archaeological evidence for it, a much larger proportion of the seventh-century population must have continued to occupy the areas of primary settlement on the Trent, as is shown by the establishment of the episcopal seat of St. Chad at Lichfield in 669.<sup>74</sup> The date of the foundation of the church, near which the saint built his house, is not known. At all events one doubts whether any considerable proportion of the large Mercian population converted to Christianity during the third quarter of the seventh century, could, at that early stage, have been accommodated with burial in churches or churchyards. The spread of church-building to the remote Peak district is likely to have been later still, hence the continued practice there of barrow-burial. A date in the eighth century for the introduction of the new custom is suggested by the archaeological material which we have considered.

The question whether there had been Anglian penetration of the Peak district in the pagan period must be answered in the affirmative in view of heathen place-names such as Wensley.<sup>75</sup> There are not a large number of such place-names. Names in -low prefixed by an Anglian personal name do not necessarily antedate the conversion and do not prove that the individual named is buried in the barrow. The archaeological evidence is by no means so clear.

Although the area is specially rich in funerary remains which may be safely assigned to the neolithic and bronze-age periods, much doubt remains about the burial practices current in the iron age, the Roman period and the fifth and sixth centuries. In particular, there is a small group of barrows covering the remains of funerary pyres, usually without grave-goods other than potsherds and flint chips, which authorities have long hesitated to assign to any one period. These were discussed in the Victoria County History under a separate heading since it was uncertain whether they were prehistoric or Anglian.<sup>76</sup> A new light was thrown on this problem through W. Fraser's painstaking rediscovery of Bateman's 'tumular cemetery' at Heath Wood, Ingleby (Bateman's 'Foremark Hall'), and the consequent excavation of several barrows of the type in question, which proved to be Danish Viking cremations and cenotaphs of the ninth century.<sup>77</sup>

<sup>73</sup> K. Cameron, *Place-Names of Derbyshire*, 1 (Engl. Place-Name Soc., xxvii, 1959), p. xlii.

<sup>74</sup> *Op. cit.* in note 64, bk. iv, ch. 3.

<sup>75</sup> *Op. cit.* in note 73, p. xxv.

<sup>76</sup> *V.C.H. Derbyshire*, 1, 186 ff.

<sup>77</sup> Full bibliography, *Derbys. Archaeol. J.*, LXXVI (1956), 51

Whether the whole group of barrows containing cremations *in situ* must now be assigned to the Viking age is not so certain. If so, their distribution should be studied as affording evidence for the settlement of the Danes in the Peak, complementary to the witness of place-names. But caution and, above all, further excavation are required. Some of the barrows may yet be prehistoric, and, as Leeds reminded us in connexion with Ingleby, cremation *in situ* under a barrow was sometimes practised by the Saxons as, for example, in the notable instance of Asthall (Oxon.), a seventh-century barrow.

Evidence of Anglian cremations in our area is not altogether lacking. A barrow near *Cold Eaton* (Carrington, 1851)<sup>78</sup> yielded a primary deposit of burnt human bone in a small hole in the old ground surface, accompanied by iron fragments, parts of two bone combs and twenty-eight bone playing-pieces or counters of the kind found in Anglo-Saxon contexts at Oxton (Notts.) and elsewhere. The barrow was earthen in the Anglian fashion, unlike the Danish barrows at Ingleby, which contained sizable sandstone blocks made up into false cairns. Cremation had not taken place *in situ*. The counters are not objects which are closely datable in the light of present knowledge. Several examples occur in inhumation-graves of the seventh century, as at Sarre, Faversham and Bishopsbourne (Kent), Basingstoke (Hants), Bishops Cannings (Wilts.), Shudy Camps (Cambs.), Keythorpe Hall, Tugby (Leics.) and Oxton (Notts.); the more elaborate 'draughtsmen' of Taplow (Bucks.) and Castle Bytham (Lincs.) are also of this date. Counters from cinerary urns, not so easily datable, are best known in East Anglia, at Pensthorpe, Castle Acre and Illington (Norf.) and Lackford, Tuddenham and Eye (Suff.). The relevant urns from Pensthorpe and Lackford are assigned to the fifth century by Myres and Lethbridge respectively. If this early date is correct, then the counters may be imported from abroad, since they are lathe-turned, and since there is no other evidence for the use of the wheel by the Anglo-Saxons at this stage.

The Cold Eaton site has an importance which has been generally overlooked, since it reminds us that upon occasion the Angles practised cremation without urns, and suggests that other cremations unaccompanied by recognizable Anglian furniture have either been passed over without remark or classified with similar prehistoric cremations. Is this why recognizable sites in the Trent valley are few compared with what one might have expected in pagan Mercia? The existence of Anglian unurned cremations, by the way, makes it even more difficult to distinguish between the primary and secondary use of barrows by the Angles; the primary deposit in the barrow at Hough-on-the-Hill (Lincs.), for example, was a cremation without urn or grave-goods.

A second instance of Anglian cremation in our area is that at *Bole Low* or *Bone Low*, near Bamford, where three or four cinerary urns were recovered by labourers in 1780 from a mound which contained also a large number of undatable inhumations.<sup>79</sup> Unfortunately the urns are not extant, but the pot shown in the drawing with which Bateman illustrates his note on this site can hardly have

<sup>78</sup> *Ten Years*, p. 179 f.

<sup>79</sup> *Id.*, p. 253; *V.C.H. Derbyshire*, I, 265.

been anything but an Anglian urn. The barrow was near the line of the Roman road from Buxton to Sheffield.

The cremations from Cold Eaton and Bole Low, then, supply a welcome link between the urn-field and mixed-rite flat-grave cemeteries of the middle Trent area, mostly of the sixth century, and the seventh-century barrow-inhumations of the Peak.

Another useful link is afforded by M. Posnansky's excavation of at least one Anglian cinerary urn, two Anglian inhumations and the associated objects from at least one other inhumation as secondary intrusions in one of a group of barrows at *Swarkeston*, five miles south of Derby.<sup>80</sup> The primary deposit had been a cremation of bronze-age date. The Anglian grave-goods belong to the sixth century on the strength of a cruciform fibula of Åberg's type III, and through the flanged form of a shield-boss handle. Posnansky's researches demonstrate also the existence of numbers of ruined round barrows in the Trent valley.<sup>81</sup> While many of them are, no doubt, prehistoric, as he supposes, it is surely significant that the first example to be excavated, *Swarkeston*, proves to contain at least four Anglian graves in secondary positions, and may well contain more, since the larger part of the mound remains untouched.

In short, the contrast between the flat-grave cemeteries of the Trent and the barrows of the Peak may be due at least in part to the obliteration of barrows in the former region contrasted with the fine preservation of barrows on the moors. In England generally, most extant Anglo-Saxon barrows which have datable material at all may be shown to be seventh-century. Yet sixth- and even fifth-century Anglian barrows are known. It must suffice to cite *Pensthorpe*, where 'a large number of small barrows' covered fifth- and sixth-century urns of an extensive cemetery, *Earsham*, *Northwold*, *Sporle* (all in Norfolk), *Linton* (Cambs.), *Stapleford Park* (Leics.) and *Kirton Lindsey*, *Hough-on-the-Hill* and *Flixborough Warren* (Lincs.), some containing both sixth- and seventh-century material. The sites named are deliberately chosen to illustrate the occurrence of pagan Anglian barrow-burials in counties where there is least evidence in the place-names for Romano-British survival, so as to dispose of the idea that the use of barrows in the Peak has to do with the survival of British elements in the Anglian population.<sup>82</sup> The continental Angles and Saxons practised barrow-burial; it is more economic to suppose that they continued to do so in England, than that they stopped, only to begin again mysteriously in the seventh century, at the very time when, one supposes, Christianity was in process of altering their eschatological beliefs. Seventh-century barrows tend to be preserved more than earlier ones in so far as many of them occur on marginal land, such as the Peak district, in which there is little evidence for an Anglian population earlier on.

Our progress so far has been straightforward, and it has not proved difficult to explain the Christian, 'Kentish' and barrow-building proclivities of the Peak-

<sup>80</sup> *Derbys. Archaeol. J.*, LXXV (1955), 123 ff.

<sup>81</sup> *Id.*, LXXVI (1956), 10 ff., map II.

<sup>82</sup> *Op. cit.* in note 9, pp. 134 ff.



dwellers, as detected by Margaret Fowler. Her Celtic and romanizing elements, on the other hand, pose a difficult problem.

It is important to notice that the place-name evidence, while it provides instances of the survival of British place-names in Derbyshire, fails conspicuously to provide them in the area covered by the Anglian barrows.<sup>83</sup> Apart from this hint, one has only the evidence of the archaeological remains, the value of which in this connexion is highly questionable. For, given that there was a Romano-British survival, it is surely a fallacy to suppose that the material culture of a mixed Anglo-British population would of necessity accurately reflect the true proportions of Celt and Angle in its make-up. A most pertinent difficulty is that there is no dated archaeological material which may be assigned to any native British population of our area in the fifth, sixth and seventh centuries. To prove the survival of British cultural traditions in the Anglian assemblages it would be necessary to find objects of indubitable British connotation and local manufacture in unequivocally Anglian contexts. There are virtually none.

The silver haunches of the boar of the Benty Grange helmet were cut out of a piece of Roman silver.<sup>84</sup> Apart from this, it is the annular and penannular 'brooches' (FIG. 12, *a-l*) which are most relevant to our problem and which have been adduced as showing British survival. A less homogeneous collection of rings it would be hard to find. As has been seen, FIG. 12, *a-c*, from Stand Low and Wyaston are not annular brooches at all, and FIG. 12, *d*, from Wyaston would make a very odd one. FIG. 12, *f*, from Wigber Low, on the other hand, much resembles penannular brooches of a type which Savory has recently shown to be most probably British or Welsh in origin.<sup>85</sup> It constitutes, in fact, our only instance of an object with Celtic connexions being found actually in an Anglian context in the Peak, although two other penannular brooches, this time certainly of Celtic manufacture, occur in our area as isolated finds. The first of these, FIG. 12, *g*, from *Pike Hall*,<sup>86</sup> is a large bronze penannular brooch with zoöomorphic terminals, belonging to Savory's Caerwent type. The date of this type is still regarded as controversial, in spite of examples in good sixth-century Anglo-Saxon contexts at High Down (Sussex) and Nassington (Northants.). Here, it is no more evidence of a native British element in the English population than is the gilt-bronze brooch (PL. III, B) from *Bonsall*, near Matlock (1862),<sup>87</sup> another isolated find, an eighth-century piece of Irish manufacture. These two Derbyshire penannular brooches, *Pike Hall* (possibly sixth-century) and *Bonsall* (eighth-century) were probably acquired by trade and cultural contact with the Celtic centres in which they were manufactured.

The rest of the alleged romanizing material in Derbyshire is not acceptable for various reasons and is relegated to the Appendix (pp. 48 ff.).

<sup>83</sup> *Op. cit.* in note 73, p. xxi f.

<sup>84</sup> *Annual Report of the Sheffield City Museum*, 1955-56, p. 14.

<sup>85</sup> *Op. cit.* in note 5, pp. 40 ff.

<sup>86</sup> *Proc. Roy. Irish Acad.*, sect. C, XLIII (1937), no. 13, p. 448, no. 85.

<sup>87</sup> *V.C.H. Derbyshire*, I, 270.

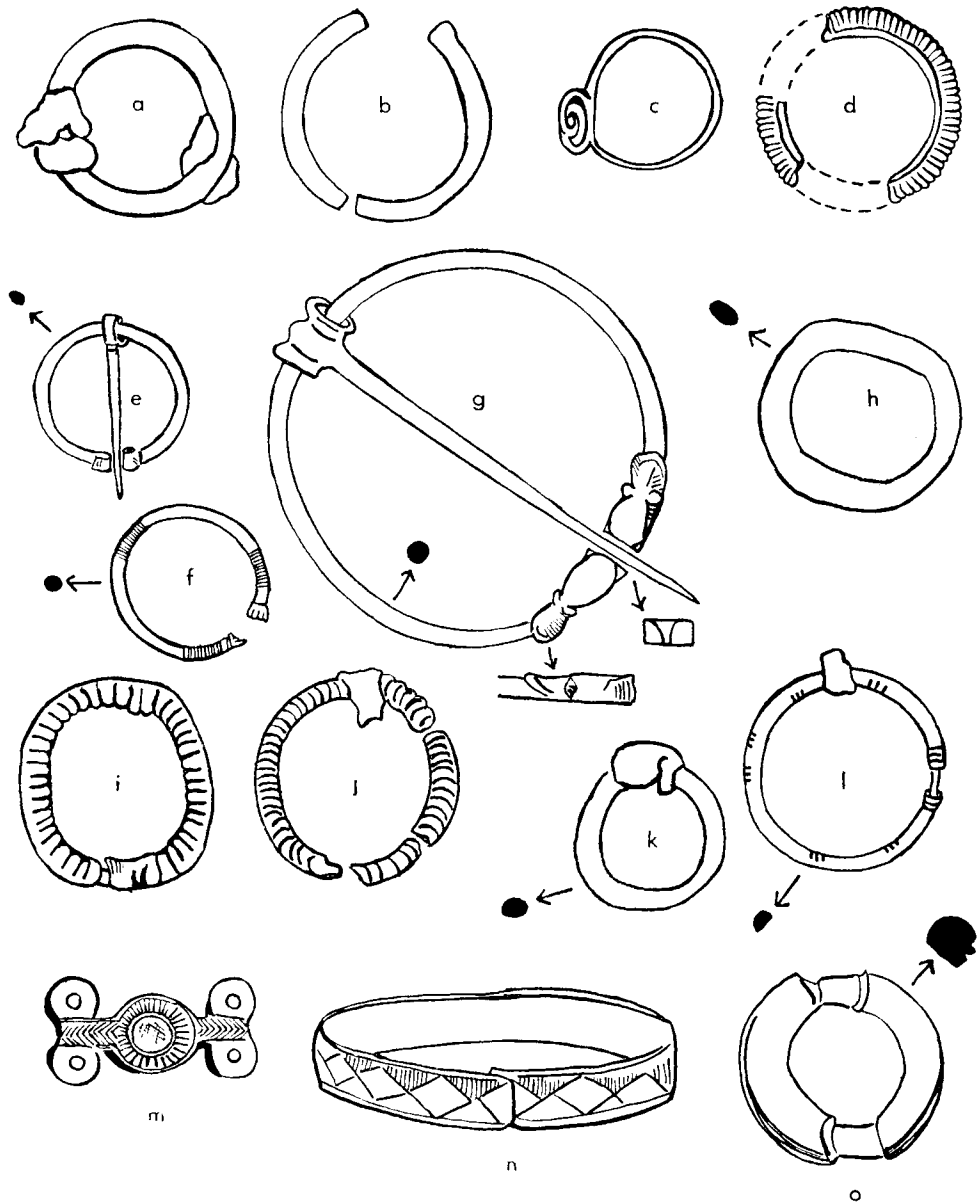

FIG. 12

METALWORK (*a-n*) AND BONE RING (*o*) FROM DERBYSHIRE AND STAFFORDSHIRE  
Sc.  $\frac{2}{3}$

*a, b*, bronze rings, Stand Low (p. 31); *c, d*, silver ornaments, Wyaston (p. 30); *e*, bronze brooch, Kenslow (p. 51); *f*, silver brooch, Wigger Low (p. 30); *g*, bronze brooch, Pike Hall (p. 39); *h*, iron ring, Nettles, near Blore (Table, p. 43); *i, j*, bronze annular brooches, Musden IV (p. 44); *k, l*, iron and bronze rings, the Burrough Fields, Wetton (p. 46); *m*, silver-plated bronze ornament, Hurdlow (p. 31); *n*, bronze bracelet, Castern (p. 50); *o*, bone ring, Winster (p. 49). *a-d, i, j*, after water-colours by Ll. Jewitt

## STAFFORDSHIRE

Fewer relevant grave-groups are known from Staffordshire than from Derbyshire, but, such as they are, they tend to confirm the conclusions reached for the neighbouring county.

The two best-known seventh-century finds do not come from barrows. They are the *Forsbrook* pendant,<sup>88</sup> an isolated find, and the flat-grave inhumation with a hanging-bowl from *Barlaston* (Wedgwood, about 1851).<sup>89</sup> The *Forsbrook* jewel (PL. IV, B) consists of a cast from a coin of Valentinian II mounted in gold, inset with cloisonné garnets over a gold foil backing and cloisonné blue glass, with a cylindrical cloisonné loop. The edge is ornamented with two strands of beaded wire separated by one strand of plain wire, which terminate on each side of the loop in an animal head. The design of the cloisons is exactly matched in a disc-brooch from *Chartham Down* (Kent).<sup>90</sup> It is simpler than in the case of the similar coin-pendants from *Wilton* and *Bacton* in Norfolk (PL. IV, A, C). Of these the *Wilton* pendant, an equal-armed cross, is specifically Christian and has the distinctive mushroom-shaped cloisons of the *Sutton Hoo* workshop; the *Bacton* jewel, a disc, has a wreath-like cloisonné pattern which cannot be closely matched but which belongs surely to the same mid seventh-century phase (see above, p. 26 f.). Although the *Forsbrook* piece is less sophisticated both in its cloisons and its loop than the other two, one would be disinclined to give it a different date.

A few brief remarks on the date of the *Barlaston* bowl (FIG. 9, *b*) must suffice if we are to avoid a lengthy reconsideration of the whole problem of hanging-bowls. The bowl has been spun, not cast as has previously been stated. Like the *Grindlow* bowl, it has a simple incurved rim somewhat thickened at the lip. We have already noticed, for *Grindlow*, that it is more than doubtful whether the typological development of the bowl-rims from this simple to the flanged type is an infallible guide to date. *Françoise Henry* in 1936 regarded the unflanged bowls as sixth century;<sup>91</sup> but, although she assigned the *Barlaston* bowl to this early type, she showed at the same time that the millefiori glass with which its enamelled escutcheons are studded is a phenomenon of Irish origin, appearing on hanging-bowls first in the seventh century.<sup>92</sup> A seventh-century date for our bowl is indeed the most likely, especially in view of her more recent paper suggesting that the Irish techniques of enamelling and millefiori found their way into English contexts by way of monastery workshops in England.<sup>93</sup> The *Barlaston* enamels afford no grounds for a precise dating. They are not unusual, the pelta motif of the *Barlaston* print being matched on the escutcheons of the *Mildenhall* bowl, and the design of the *Barlaston* escutcheons matched on Irish enamels. The enamels are ill-executed and already the introduction of millefiori insets has had a deleterious effect upon the enamelled pattern. Millefiori does not

<sup>88</sup> Åberg, *op. cit.* in note 32, p. 137, fig. 264.

<sup>89</sup> *Archaeologia*, LVI (1898), 44.

<sup>90</sup> Leeds, *op. cit.* in note 32, pl. xxix, *a* (top centre).

<sup>91</sup> *Op. cit.* in note 14, p. 245.

<sup>92</sup> *Ibid.* pp. 237, 239.

<sup>93</sup> *Op. cit.* in note 5, pp. 71 ff.

TABLE  
MINOR ANGLIAN SITES

DERBYSHIRE

<i>Site of barrow</i>	<i>Diameter of barrow</i>	<i>Excavation</i>	<i>Context</i>	<i>Sex</i>	<i>Position</i>	<i>Orientation</i>	<i> Finds</i>	<i>Sheffield Museum Catalogue No.</i>	<i>References</i>
Middleton by Wirksworth	—	Destroyed 1787	Primary	Male	Extended	—	Spear-head	—	<i>Vestiges</i> , p. 25
Middleton Moor	40 feet	W. Bateman, 1824	Two primaries	One male	Confused	—	Lance-head Awl	— J93.1164	<i>id.</i> , p. 32
Cross Flatts, Middleton by Youlgrave	—	<i>id.</i> , 1827	Primary	'Young person'	Extended	—	2 Knives	J93.1139 J93.1140	<i>id.</i> , p. 34
Near Minninglow	Small	T. Bateman, 1843	Secondaries	—	—	—	Knife Hone	J93.1170 J93.130	<i>id.</i> , p. 41 <i>Ten Years</i> , p. 83
30 yards south of Arbor Low	Small	<i>id.</i> , 1844	—	Male	—	—	Socket of spear-head	J93.1158	<i>Vestiges</i> , p. 57
Carder Low, near Hartington	14 yards	<i>id.</i> , 1845	Secondary	Male	—	—	Knife 3 Hones	J93.1166	<i>id.</i> , p. 63
Pilsbury, Hartington	—	<i>id.</i> , 1847	Secondary	Male	Extended	—	Knife	J93.1180	<i>id.</i> , p. 105
Rusden or Rushden Low	—	<i>id.</i> , 1848	Secondary	No skeleton with the Anglian find			Bone comb Knife	J93.687 J93.688	<i>Ten Years</i> , p. 43
Ryestone (Roystone) Grange, near Minninglow	11 yards	<i>id.</i> , 1849	Secondary	—	—	—	Knife	J93.699	<i>id.</i> , p. 61
Between Hurdlow and Buxton, I	9 yards	<i>id.</i> , 1849	—	—	—	—	Knife  Both these barrows were earthen in the Anglian fashion, see above p. 34.	J93.1160	<i>id.</i> , p. 54
<i>id.</i> , II	11 yards	<i>id.</i> , 1849	Primary	Male	Extended	Head west			
Near Nether Low, Chelmorton	Small	<i>id.</i> , 1849	Primary	Male	Extended	Head west	Knife	J93.1157	<i>id.</i> , p. 51
Hay Top, near Cressbrook, Monsaldale	20 yards	<i>id.</i> , 1851	Secondary	Skeleton fragmentary and disturbed but presumably male			Spear-head Bead	J93.695 J93.694	<i>id.</i> , p. 74
Near Chelmorton Thorn	9 yards	<i>id.</i> , 1859	Primary	Male	Extended	Head west	2 Knives Iron buckle	J93.1154	<i>id.</i> , p. 105
Longstone	—	Lucas, 1868	—	—	—	—	Scram-seax Pointed rod	British Museum 1873.6-2. 106, 107	—

## STAFFORDSHIRE

Castern	35 yards	T. Bate- man, 1845	Second- ary	The relevant find not with any one skeleton			Knife with horn handle	—	<i>Vestiges</i> , p. 45
Steep Low, near Alstonefield	50 yards	<i>id.</i> , 1845	Second- ary	Male	Extend- ed	—	Spear- head Spear- head Knife Arrow- head	J93.1130 J93.1135 J93.1150 J93.1133	<i>id.</i> , p. 76 <i>Ten Years</i> , p. 121
Readon or Wredon Hill	19 yards	Carring- ton, 1848	a) Prim- ary b) Second- ary	Male Male	Extend- ed Extend- ed	— —	Pebble in right hand { Spear- head Knife	J93.1152 J93.1153	<i>id.</i> , p. 122
Blore's Field, Calton	16 yards	<i>id.</i> , 1849	Second- ary	—	Extend- ed	—	Knife	J93.697	<i>id.</i> , p. 128
Nettles or Net Lows, near Blore	13 yards	<i>id.</i> , 1849	Second- ary	—	—	—	Sherds Iron ring FIG. 12, h	Not extant J93.1168	<i>id.</i> , p. 142

## POSSIBLE ANGLIAN SITES

## DERBYSHIRE

Sharp Low, near Tissington	—	T. Bate- man, 1848	Second- ary	—	Contract- ed	—	Knife Sherds	J93.1144 Not extant	<i>Ten Years</i> , p. 26
Vincent Knoll, near Parcelly (Parsley) Hay	Large	<i>id.</i> , 1849	Second- ary	Male	'Hud- dled'	—	Spear- head	J93.1165	<i>id.</i> , p. 49

occur in Anglo-Saxon archaeological contexts certainly datable in the early decades of the seventh century. Sutton Hoo sees its début. Elsewhere, beads and pendants of millefiori or of glass inset with millefiori do not occur except rarely and in graves of the 'Christian Saxon' period as at Westbere, Sarre, Sibertswold, Barfriston (Kent), Burwell, Shudy Camps (Cambs.) and Purwell Farm, Cassington (Oxon.).<sup>94</sup>

The Barlaston grave contained a sword and knife also and was therefore that of a man. No trace of the skeleton remained, but the disposition of the goods suggests that it had its head to the south. There was no trace of a barrow, but the pasture field in which the find was made had been ploughed 'at some previous time'. There were no other graves in the vicinity.

<sup>94</sup> *Antiq. J.*, xxvi (1946), 16, pl. ii (top right); *Archaeol. Cantiana*, vi (1866), 160, grave 20, vii (1868), pl. vii; Faussett, *op. cit.* in note 2, pl. iv, 7-9; Lethbridge, *op. cit.* in note 39, p. 51 and *op. cit.* in note 18, p. 5; *Oxoniensia*, vii (1942), 64.

Unfortunately only one Staffordshire barrow affords an unequivocally seventh-century find. This is one of the barrows on the *Cauldon Hills* (Carrington, 1849),<sup>95</sup> which contained an inhumation, sex and orientation unknown, accompanied by a burnished black bottle-shaped pot (FIG. 13, *a*). This bottle is not extant but is known from one of Jewitt's illustrations. It is matched at Faussett's seventh-century Kentish sites, as for example at Kingston and Barfriston.

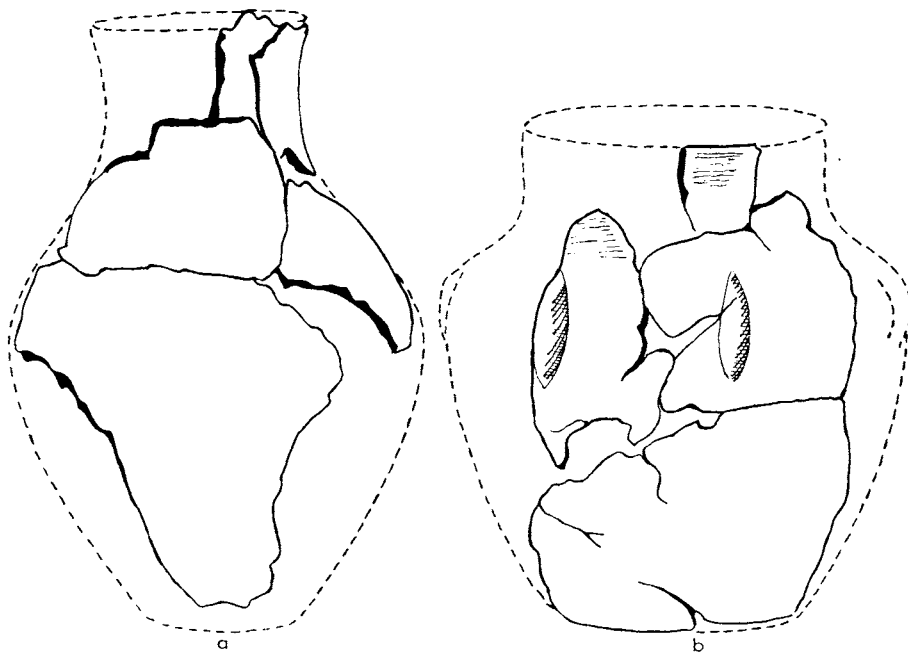

FIG. 13

POTTERY FROM STAFFORDSHIRE (p. 44 f.). Sc. not certain

*a*, bottle, Cauldon Hills; *b*, cremation urn, Musden II. After water-colours by Ll. Jewitt

*Barrow IV, Musden Hill* (Carrington, 1849),<sup>96</sup> however, yielded a pair of annular brooches which may well be of the seventh century. No details are given of sex, orientation or posture of the skeleton with which they were associated, which was one among several prehistoric and undatable inhumations in secondary positions in the mound. Margaret Fowler lists the annular brooches among finds showing Roman or Celtic traditions alive in Anglian contexts. But there is much to be said against this interpretation. As is well known, annular and penannular brooches derive from iron-age and Romano-British prototypes. Important studies have been made of later specifically Celtic penannular brooches which sometimes, but not very often, occur in Anglo-Saxon contexts.<sup>97</sup> The occurrence of brooches of distinctively Celtic manufacture as at Pike Hall may be due to

<sup>95</sup> *Ten Years*, p. 153; *op. cit.* in note 9, p. 147. Bateman's account reads as though the inhumation might have been primary. Margaret Fowler regards it as secondary.

<sup>96</sup> *Ten Years*, p. 148; *op. cit.* in note 9, p. 143, fig. 5.

<sup>97</sup> *Op. cit.* in note 5, pp. 40 ff.

trade contacts between the two peoples. A wholly separate matter was the taking up of the basic penannular and annular types by the Anglo-Saxons themselves during the fifth, sixth and seventh centuries, and the manufacture of distinctive Anglian varieties. Such brooches were worn to secure and ornament the dress, not as tribal emblems. Their popularity in East Anglia and Yorkshire cannot be taken as implying the presence of proportionate Romano-British elements in the population. For both types, further research is required upon local and chronological variations. Pairs of broad flat annular brooches have long been recognized as a typically Anglian fashion in the sixth century (as at Girton and St. John's at Cambridge, and Holywell Row in Suffolk), and Leeds has remarked that in the seventh century this fashion gives way to smaller round-sectioned annular brooches, plain, or decorated with groups of transverse lines or transverse mouldings.<sup>98</sup> At Musden IV we have a pair of round-sectioned brooches decorated with continuous transverse lines (FIG. 12, *i, j*), a sub-type which has not yet received much attention. Parallels occur at Saxby (Leics.), where there is one, at Garton Slack (Yorks.), where there is one in a seventh-century context, at Melbourn (Cambs.), with one in grave 8, and at Holywell Row (Suff.), where there is a pair in grave 11.<sup>99</sup> The Melbourn cemetery is wholly in the tradition of Lethbridge's 'Christian Saxon' sites at Burwell and Shudy Camps and dates, at the earliest, from the second half of the seventh century. Holywell Row spans the sixth and earlier seventh centuries and overlaps to some extent with the Burwell-Melbourn group: of grave 11, which contained a large assemblage of worn and broken objects, Lethbridge writes 'it is improbable that the burial took place earlier than the seventh century, and it may even be as late as the middle of it'. In the light of present knowledge, a date in the seventh century would seem to be most likely for the Musden brooches also.

Evidence for the use of groups of barrows by the Angles in Staffordshire is seen only at Musden, where a second barrow, *Musden II* (Carrington, 1848),<sup>100</sup> yielded an undatable primary cremation, without grave-goods, a secondary inhumation, head to the east, with a formless lump of flint, and the remains of two cinerary urns. These urns are not extant, but one is known, fortunately, from an illustration by Jewitt (FIG. 13, *b*), and was clearly Anglian. The knobbed projections appear to have been applied rather than pushed out from inside. Similar urns met with at Sleaford (Lincs.) and Lackford (Cambs.) are not closely datable.<sup>101</sup> Urns with applied knobs are unlikely to be very early and a date in the sixth century is probable. The Musden II urns had contained burnt bone. With Bole Low, Bamford, this is the second instance of Anglian urned cremation in our area, and with Cold Eaton, the third instance of cremation.

Both barrow-burial and flat graves are met with at *The Burrough Fields, Wetton* (Carrington, 1845-1852),<sup>102</sup> where an Anglian cemetery was in the immedi-

<sup>98</sup> Leeds, *op. cit.* in note 32, p. 99.

<sup>99</sup> *V.C.H. Leics.*, I, 235; Mortimer, *op. cit.* in note 53, p. 251, pl. lxxxvii, fig. 673; *op. cit.* in note 8, p. 32, pl. iv, *r*; *op. cit.* in note 39, p. 9.

<sup>100</sup> *Ten Years*, p. 119 f.

<sup>101</sup> *Op. cit.* in note 7, pp. 79, fig. 5, 4, and 80; Lethbridge, *A Cemetery at Lackford, Suffolk* (Cambridge Antiq. Soc., 4to publ., n.s. vi, 1951), pp. 20, 46, fig. 24.

<sup>102</sup> *Ten Years*, pp. 193 ff.; *op. cit.* in note 9, p. 145, fig. 1.

ate vicinity of a Romano-British settlement; or one should say, rather, that this seems to be the likely interpretation of what Bateman entitles the 'desultory excavations' of Carrington and the equally desultory report of them, which is mainly in Carrington's words, though in Bateman's book. The Romano-British character of the occupation-material is not in doubt. Reginald Smith<sup>103</sup> and others have taken the contents of two flat graves and one barrow to be Anglian, but the attribution is doubtful and all three skeletons were in the immediate vicinity of Romano-British rubbish. The first flat grave contained an extended female skeleton, the head to the south, accompanied by three beads, an iron awl and nails, parts of stags' horns and the bronze annular brooch (FIG. 12, *l*). The brooch is decorated with groups of short transverse lines, and has a recess for the pin, a detail common on Anglian ring-brooches, but not on Roman ones. A very good parallel occurs at Painsthorpe Wold (Yorks.) in a seventh-century context and another at Horndean (Hants) in a seventh-century context.<sup>104</sup> The second flat grave had an extended skeleton, the orientation and sex not stated, with a knife and 'the point of a javelin'. The barrow, only nine feet across, contained an extended inhumation, the orientation and sex not stated, but presumably male, with a spear-head and knife. The size of the barrow is in favour of a British attribution, the weapons of an Anglian. An iron ring from the site (FIG. 12, *k*) does not seem to have been associated with any of the skeletons, so far as can be seen from the report. Carrington's descriptions are so muddled that one may draw no valid conclusions from the coincidence here of British and Anglian remains, which are not necessarily contiguous in date.

As in Derbyshire, so in Staffordshire there are some Anglian secondary interments in barrows associated with objects such as spear-heads and knives which are not closely datable. They are listed in the Table (p. 42 f.). There are also a few isolated surface finds probably of Anglian date, as for example a glass bead and a spear-head from near Throwley.<sup>105</sup>

The barrows are restricted to the small area of the Carboniferous Limestone in the north-east of the county, where they are adjacent to the Derbyshire barrows, forming part of what is essentially one cultural group.

By the time of the Domesday Book this part of Staffordshire was as sparsely populated as any, not excepting the forested Bunter Sandstones of Cannock Chase and the Keuper Red Marls of Needwood.<sup>106</sup> It had less useful woodland, fewer mills, fewer ploughs and fewer people than the rest of the county, which nowhere supported a dense population as compared with the counties of eastern England. Parts of it were further wasted by William. It is clear that in the eleventh century even the Red Marl, forested, and by no means suitable for primary settlement, was preferred to the Carboniferous Limestone, which then and since has been wind-swept open moorland.

One is forced to the conclusion that the preservation of so many barrows

<sup>103</sup> *V.C.H. Staffordshire*, I, 208.

<sup>104</sup> Mortimer, *op. cit.* in note 53, p. 117, pl. xxxv, fig. 277; *Papers and Proc. Hants. Field Club*, xix (1957), 135 and fig. 10, 7.

<sup>105</sup> *Op. cit.* in note 71, pp. 227, no. J 93. 722 and 232, no. J 93. 1131.

<sup>106</sup> *Proc. N. Staffs. Field Club*, lxxxvii (1953), 31 ff.



on the Limestone formation is an accident of the geography. The main part of the Mercian population of Staffordshire in the seventh century was concentrated not here, but in the Trent valley in the environs of the sixth-century pagan Anglian sites of Stapenhill, Wichnor and Walton-on-Trent. Here was the centre of primary settlement, in so far as there was any in this so heavily forested county, and here were the historically-attested centres of Mercian life at Lichfield and Tamworth. Barrows have been obliterated in this area, which has been intensively ploughed since the conversion. It is more than likely that the Barlaston inhumation, for example, on the Bunter Sandstone, once lay under a mound.

### CONCLUSION

The barrows of north-western Derbyshire and north-eastern Staffordshire, obviously enough, may be ascribed to the ancestors of the *Pecsaetan* of the Tribal Hidage. Similar seventh-century barrows belonging to other Anglo-Saxon settlers are nearly always found on land which at that period would have been marginal. The barrow at Oxton, containing *inter alia* a 'sugar-loaf' shield-boss and fifteen playing-counters, the only datable seventh-century grave in Nottinghamshire known to me, was in Sherwood Forest.<sup>107</sup> A seventh-century barrow at Ingarsby is on the Leicestershire Wolds where early finds are absent.<sup>108</sup> Another at Stoke Golding (Leics.) is on the line of Watling Street, where it cuts between the forests of Charnwood and Arden.<sup>109</sup> Another at Compton Verney (Warwicks.), which yielded a Christian-looking pendant dating not earlier than about 675, is on the line of the Fosse Way as it skirts the forested areas.<sup>110</sup> To turn to districts occupied by the Jutes and Saxons, we find Faussett's great series of seventh-century sites and the Wiltshire barrows recently enumerated by L. V. Grinsell<sup>111</sup> all on over-dry chalkland where earlier Saxon remains are absent. We do not need the historical evidence to know that the seventh-century population was not concentrated in these localities.

To sum up, during the course of the seventh century the English population began to expand from its earliest settlements on the glacial gravels and similar good soils on to less favourable, marginal soils. There they formed communities which tended to be a little backward and isolated, and, probably, a little slower to have churches built for them and to abandon the rite of barrow-burial. Their barrows are often preserved where their territory was so marginal as never to be intensively ploughed. Meanwhile, the missionaries and church-building came first, naturally, to the bulk of the population remaining in the areas of primary settlement, where vast numbers of barrows have been obliterated and where the transition from barrow-burial to burial in churchyards may well have occurred earlier. Here, barrows are preserved only in exceptional circumstances, as for example when barrow-site and churchyard were combined at Taplow (Bucks.).

<sup>107</sup> *Archaeologia*, x (1792), 381 ff.

<sup>108</sup> *V.C.H. Leics.*, 1, 238 f.

<sup>109</sup> *Antiq. J.*, xii (1932), 174.

<sup>110</sup> *Archaeologia*, iii (1775), 371; *V.C.H. Warwicks.*, 1, 264 f., fig. 10.

<sup>111</sup> *V.C.H. Wilts.*, 1, 242 ff.

## APPENDIX

## FINDS WRONGLY OR DOUBTFULLY ATTRIBUTED TO THE ANGLO-SAXON PERIOD

It would be unwise to follow Bateman in the belief that all inhumations in barrows found associated with iron objects are necessarily Anglo-Saxon. One must consider what burial practices were current in the pre-Roman age, in the Roman and sub-Roman periods and at the time of the Vikings.

A most pertinent problem arises from the difficulty of distinguishing iron-age graves in our area, which is known to have been inhabited at that time. The best line of approach at first seemed to be by analogy with iron-age graves in east Yorkshire. I. M. Stead has been kind enough to discuss the material with me in the light of his knowledge of Yorkshire, and has provided most valuable information and observations. He pointed out that this suggested analogy between the east Yorkshire iron-age graves and supposed iron-age graves in Derbyshire was rash, in so far as major differences of burial practice existed between east and west Yorkshire within the iron age, and the practices in Derbyshire might well have been different again.

In east Yorkshire, the iron-age rite was one of contracted, or, less often, extended inhumation in large cemeteries of small individual barrows. Iron knives and spear-heads are not known to have accompanied the dead, except very rarely. By analogy, therefore, the graves listed in the Table (p. 42 f.), which are mainly extended interments placed as secondaries in large barrows with spear-heads or knives, are probably Anglian rather than iron-age. The only really small Peakland barrow in question is the one at Burrrough Fields, Wetton (p. 46). Where the skeletons are contracted or 'huddled' as at Sharp Low, near Tissington, and Vincent Knoll, near Parcelly Hay (p. 43), there is somewhat more reason to suspect an iron-age date: but contracted inhumation was practised by the Angles also (as for example at Sleaford, Lincs.), and where there are spear-heads or knives, an Anglian date is more likely. The attribution of all the sites in the Table to the Angles, however, leaves us without iron-age barrow-burials, a most incomprehensible blank in the record. Faced with a similar problem in Wiltshire, Grinsell has assigned the contracted skeletons to the iron age and the extended ones to the Saxon period.<sup>112</sup> He notes also an extended inhumation of the Viking period in Silbury Hill.

The Romano-British are known to have practised barrow-burial in the Peakland, as is shown by some of the finds listed in the catalogue of the Bateman collection,<sup>113</sup> which include first- or second-century brooches. The first assumption, therefore, when barrow-burials are associated with Romano-British goods, is the simple one that they are Romano-British graves and not that they represent romanizing elements in Anglian contexts. No graves are certainly attributable to the British population of the fifth, sixth and seventh centuries, and, since one knows next to nothing of this later Celtic material culture as such, one has to be chary of identifying its influence in the Anglian graves.

At least one site, Winster, has been regarded as Anglian but is almost certainly iron-age. Roman finds—the vessel and disc from The Low, Newhaven House, and the bracelet from Castern—have been accepted as illustrating romanizing elements in the Anglian material culture merely because they occur in barrows. Objects which it is frankly impossible to date—the bronze vessel from a barrow near Thor's Cave, Wetton, and the Kenslow penannular brooch—have been similarly regarded. Most of the finds in question are not easy to date in the light of present knowledge, and attributions remain doubtful. None of them, however, combines indisputable Romano-British artefacts in certain Anglian contexts.

<sup>112</sup> See the preceding note.

<sup>113</sup> *Op. cit.* in note 71, p. 183, no. J 93. 559, p. 195, no. J 93. 626, p. 196, no. J 93. 627 and p. 200, no. J 93. 669.

WINSTER, DERBYSHIRE (T. BATEMAN, 1856).<sup>114</sup>

The finds comprised two contracted male inhumations buried nine feet apart, heads to the north-east. The first was accompanied by an iron spear-head and the lower half of a quern, the second by a larger spear-head, an iron tool like a bill-hook, a ring of calcined bone or antler (FIG. 12, *o*),<sup>115</sup> the upper half of the same quern and a fragmentary clay vessel (FIG. 14). The bodies were covered with stones. Beneath them were ashes and fragments of burnt bone and wood, and the covering stones, querns and weapons had, Bateman believed, been burnt *in situ* on pyres; the bodies had not been burnt.

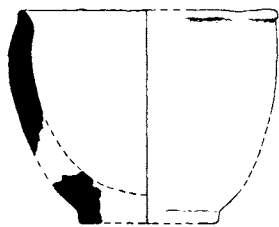

FIG. 14  
WINSTER, DERBYSHIRE  
Iron-age bowl (restored). Sc.  $\frac{1}{4}$

All the certainly Anglian inhumations in the Peak district for which the facts are known differ from the Winster skeletons in having the extended position and the Christian, head to the west, orientation. In the circumstances, it is fortunate that the date of Winster may be determined by the pottery, which one may attribute to the iron age with a fair degree of confidence. I have to thank my husband for the following comment:

'The potsherds are crude, hand-made and extremely simple, and, since there is no local material to form a basis for comparison, one must regard them with caution. Making allowance for possible local variation in clay and temper, the fabric is similar to that of the final iron-age pottery of the south midlands and Severn region, as, for example, the coarsest wares from Hunsbury (Northants.) and the lake villages (Som.). The squat shape, everted rim and thick splayed base may be matched at many sites north and west of the Thames, as, for example, at Hunsbury, the lake villages, Frilford (Berks.), Stanton Harcourt (Oxon.) and Barley (Cambs.); south of the Thames the type is better made. In Derbyshire such pottery may well have continued after the Roman conquest.'

A date not earlier than the first century A.D. is likely for the quern-stones, which are parts of a rotary hand-mill of the bee-hive shape usually attributed to the Roman period, and met with at Roman sites in the Peak, as, for example, at Melandra. The bill-hook is of a type well known from iron-age contexts, as, for example, Maiden Castle. The ring is without close parallels. It was perhaps a pulley-ring for the belt.

A likely date for the Winster finds would be the first century A.D. They are not Anglian, as has hitherto been supposed.

STANSHOPE, DERBYSHIRE (T. BATEMAN, 1852).<sup>116</sup>

The relevant finds were in a secondary position in a barrow the primary grave of which was not reached. Bateman reported fragments of burnt and unburnt human bone,

<sup>114</sup> *J. Brit. Archaeol. Assoc.*, XIII (1857), 226 ff.; *Ten Years*, pp. 98 ff.; *op. cit.* in note 9, p. 146.

<sup>115</sup> I have to thank Dr. C. Forbes of the Sedgwick Museum, Cambridge, for the identification of the material of this object. Earlier suggestions were that it was stoneware, porcelain or pumice.

<sup>116</sup> *Ten Years*, p. 187; *op. cit.* in note 9, p. 148, fig. 9.

potsherds, two burnt pieces of bronze, an iron awl and a piece of glass. The glass is post-medieval and not, as Bateman supposed, part of a palm-cup like that from Cow Low.<sup>117</sup> There is, therefore, nothing specifically Anglian from the barrow, which has been disturbed in modern times. The other finds now extant are too scrappy to be readily identifiable. They include a flint scraper which is probably neolithic or bronze-age as well as the objects listed by Bateman. Only one potsherd is extant. It is in a thick, hand-made, slightly burnished red fabric and may be of the pre-Roman iron age.

OVERHADDON, DERBYSHIRE (J. WARD, 1887).<sup>118</sup>

A barrow in Haddon Fields near Conksbury Bridge covered a grit-stone cist, in which was found the primary burial, a flexed male skeleton, head to the west, with a fragmentary rotary quern. The find was thought to be Anglian, but on insufficient grounds. The flexing of the skeleton and the quern-stone are alike reminiscent of Winster and an attribution to the iron-age or Roman periods is tempting. No certainly Anglian burial in our area is contained in a cist or is flexed.

TADDINGTON, DERBYSHIRE.<sup>119</sup>

This barrow, the precise site of which is not known, was broken into by a labourer in 1845. The burial, apparently primary, was an extended inhumation contained in a cist with the upper parts of two beehive-shaped quern-stones placed at the head and feet. Orientation and sex are not known. The find has been regarded as Anglian, but, in view of the quern-stones, may be Romano-British.

SLIPPER LOW, TADDINGTON, DERBYSHIRE (T. BATEMAN, 1851).<sup>120</sup>

The primary interment under this barrow was an extended inhumation (sex not stated), placed head to the north-west, without grave-goods. Its attribution to the Anglian period is based solely on the fact that extended inhumation under round barrows is not likely to be neolithic or bronze-age, and fails to reckon with the possibility that it may be Romano-British or Viking.

CASTERN, STAFFS. (T. BATEMAN, 1845, CARRINGTON, 1850).<sup>121</sup>

Bateman's excavation showed this barrow to contain prehistoric burials, and very probably, at least one Anglian secondary inhumation (above p. 43). A second excavation by Carrington yielded more inhumations including an extended skeleton, head to the west, sex not stated, associated with several 'flint instruments' and a bronze bracelet (FIG. 12, *n*). Anglian parallels for the bracelet at Saffron Walden and Driffield have been cited, but the former is probably Romano-British and the object at Driffield is a strap-end. On the other hand, similar bracelets are a very common Roman type indeed, occurring at all large Roman sites. There seems no reason not to accept this grave as Romano-British. There was nothing demonstrably Anglian with it.

THE LOW, NEWHAVEN HOUSE, DERBYSHIRE (T. BATEMAN, 1849).<sup>122</sup>

This mound had been badly mutilated before Bateman's excavation and one does not know whether or not the finds were associated with one another. They included unidentifiable burnt bone fragments, pieces of iron straps overlaid with bronze (compared by Bateman to the frame of the Benty Grange helmet), a bronze disc, and a cast bronze pyx. The objects are not extant, but disc and pyx are known from Jewitt's

<sup>117</sup> *Op. cit.* in note 5, p. 166, 1, *d*.

<sup>118</sup> *Derbys. Archaeol. J.*, x (1888), 47; *V.C.H. Derbyshire*, 1, 276.

<sup>119</sup> *Vestiges*, p. 84.

<sup>120</sup> *Ten Years*, p. 71.

<sup>121</sup> *Vestiges*, p. 73; *Ten Years*, p. 166; *op. cit.* in note 9, p. 142, fig. 7.

<sup>122</sup> *Ten Years*, p. 45; *op. cit.* in note 9, p. 143, figs. 2, 3.

illustrations (FIG. 15, *a, b*). The disc was decorated with raised concentric circles and a stamped pattern of chevrons and small rosettes. I know of no close parallels. Discs found in seventh-century Anglo-Saxon graves are smaller, always flat, and lack the rosettes, although they commonly have a somewhat similar pattern of concentric circles and chevrons. For the pyx, Bateman himself cites the only parallels available, which are a little bronze vessel from a Roman context at Lincoln and two from the site of Lewes priory, the Lincoln and one of the Lewes examples being decorated with equal-armed crosses. They are likely to have been Roman. Since the identification of the supposed helmet fragments is doubtful, the Anglian nature of the grave is most uncertain.

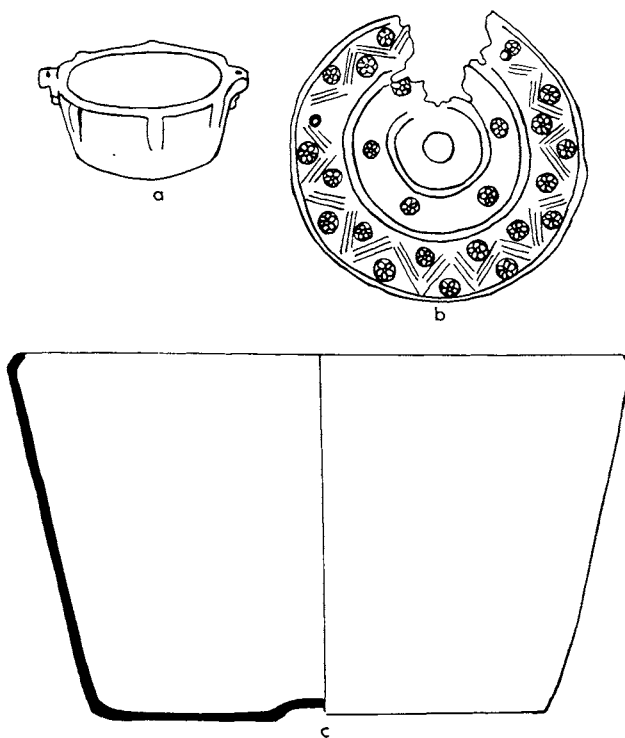

FIG. 15

BRONZE OBJECTS FROM DERBYSHIRE AND STAFFORDSHIRE (pp. 50 ff.). Sc.  $\frac{1}{2}$   
*a, b*, pyx and ornamental disc, the Low, Newhaven House; *c*, bowl, near Thor's Cave, Wetton. *a, b* after water-colours by Ll. Jewitt

KENSLOW, YOULGRAVE, DERBYSHIRE (W. BATEMAN, 1821, T. BATEMAN, 1848).<sup>123</sup>

The excavation in 1821 yielded two skeletons extended 'side-by-side', heads north-west, one certainly male and furnished with a bronze penannular brooch (FIG. 12, *e*), a quartz pebble, a red potsherd and ground stone implements. These were at first regarded as the primary burials.

When the barrow was reopened by Thomas Bateman it proved to contain pre-historic remains earlier than the two skeletons, while in the grave-pit of 1821 were found a bronze dagger and an 'Anglo-Saxon' iron knife. Thomas Bateman had therefore to

<sup>123</sup> *Vestiges*, p. 28; *Ten Years*, p. 20; *op. cit.* in note 9, p. 146, fig. 4.

reinterpret the finds of his predecessor. One skeleton must have been lower than the other, and must have been furnished with the stone implements and bronze dagger, which are certainly bronze-age. The other must have been higher in the grave, and is to be associated with the penannular brooch, the iron knife and the sherds of a narrow-necked wheel-made pot found in 1848 and said to be like the jug from Bruncliff (see below). This sort of post-excavation reconstruction is far from satisfactory.

Penannular brooches with rolled terminals may be iron-age, Romano-British or Anglo-Saxon, when they may occur in fifth-, sixth- or seventh-century<sup>124</sup> contexts. This one is very neatly faceted at the head of the pin, which inclines one to think that it may be Romano-British. Bateman's view that the grave was Romano-British seems preferable to that of Margaret Fowler, who regards it as Anglian with romanizing elements. It would be unusual to find an Anglian male skeleton with a penannular brooch. The iron knife may be British or Anglian.

BARROW NEAR THOR'S CAVE, WETTON, STAFFS. (CARRINGTON, 1850).<sup>125</sup>

The barrow yielded a sandstone bowl belonging to the bronze age and a bronze vessel (FIG. 15, *c*), whether in a primary or secondary context is not known. Margaret Fowler regards the bronze vessel as similar to one from Chessel Down in the Isle of Wight, which she believes to show romanizing or Celtic traditions in a Saxon context. But, as Åberg has shown, the Chessel Down piece is one of a group of imported Coptic bronzes of seventh-century date.<sup>126</sup> The Staffordshire vessel differs from the one from Chessel Down in being cast bronze, in having an inturned rim and omphaloid base, and in lacking ornament and perforated lugs to hold the handle. Its original iron handle is not extant. It has been badly buckled into an oval form but is drawn here as if it were straight. It is impossible to date it in the light of present knowledge. It may be Romano-British, but in no case is it evidence of Romano-British survival in an Anglian context, since the site yields no Anglian remains.

BRUNCLIFF, NEAR HARTINGTON, DERBYSHIRE (T. BATEMAN, 1847).<sup>127</sup>

In this barrow the cremated remains of a horse were associated with a primary extended inhumation, the sex and orientation not stated, furnished with an iron knife and a wheel-made trefoil-mouthed jug in red ware. It is difficult to know whether to follow Bateman and Reginald Smith, who regard the jug as a local Romano-British or sub-Roman product, or Margaret Fowler who regards it as a Frankish import. The breadth of the base is in favour of the Frankish date, and good Frankish parallels may be seen in the British Museum from St. Loup, Marne. There are, however, no close parallels in Franko-Kentish contexts in England, and it would be surprising to find a complete Frankish vessel in Derbyshire of a type not represented in Kent.

<sup>124</sup> There is one from Castle Bytham (Lincs.) found with a disc-brooch with Style II interlace.

<sup>125</sup> *Ten Years*, p. 172; *op. cit.* in note 9, p. 145, fig. 2.

<sup>126</sup> Åberg, *op. cit.* in note 32, p. 104, fig. 191.

<sup>127</sup> *Vestiges*, p. 101; *op. cit.* in note 9, p. 147, pl. i.