

Graphic Direction

# // WHITWORTH PARK EXHIBITION

Whitworth Park: Pleasure, Play and Politics  
Manchester Museum

Project Team  
23/04/14

# WHITWORTH PARK: PLEASURE PLAY & POLITICS

Graphic Direction

131\_MM\_WPEXH / Whitwoth Park: Pleasure, Play and Politics

sarah  
crossland  
//DESIGN

Exhibition space: aerial view

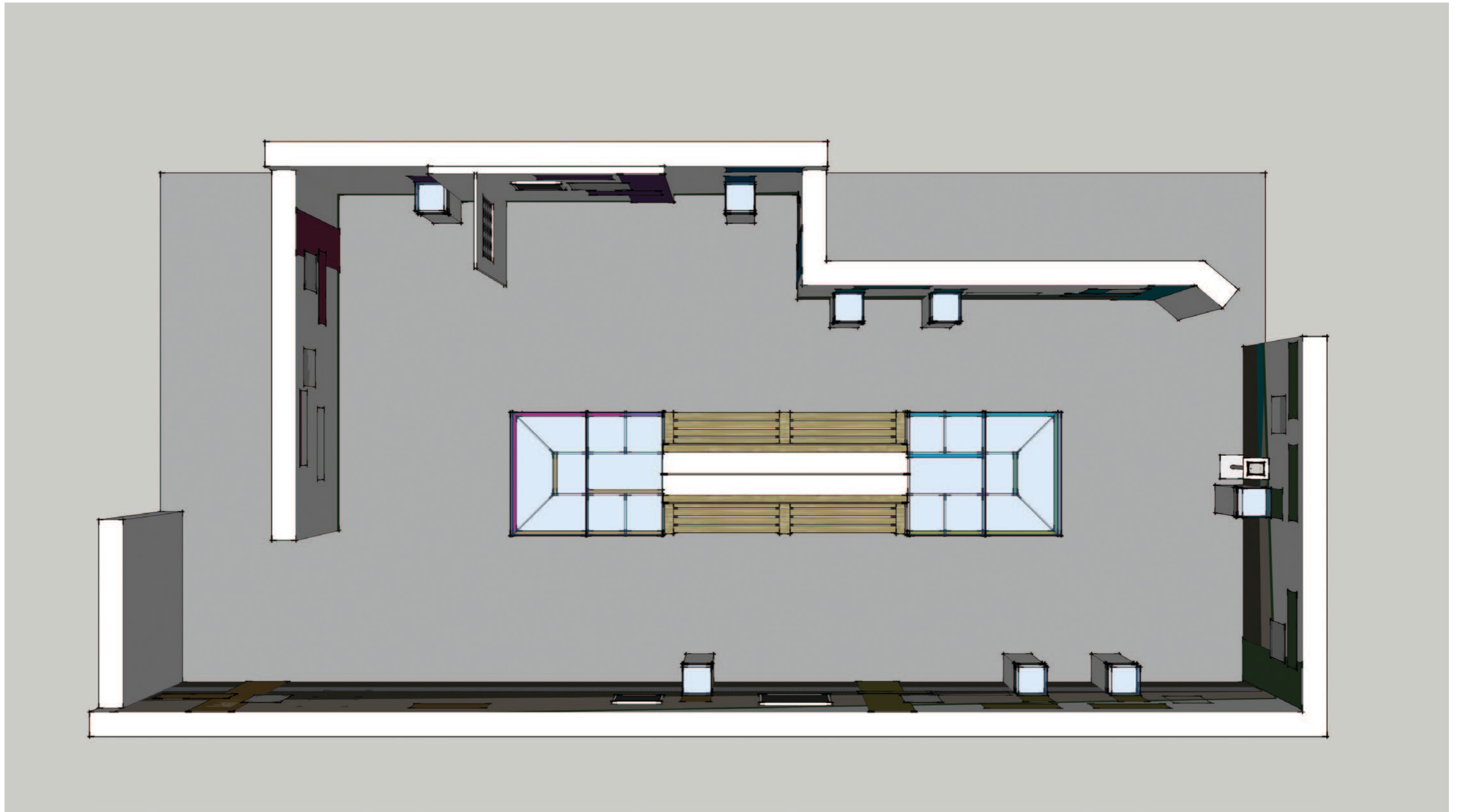

Graphic Direction

131\_MM\_WPEXH / Whitwoth Park: Pleasure, Play and Politics

**Colour palette: base colours and zones 1-7 (l to r)**



**Graphic Direction**

131\_MM\_WPEXH / Whitwoth Park: Pleasure, Play and Politics

# Graphics and aesthetics: Elevation and paint detail

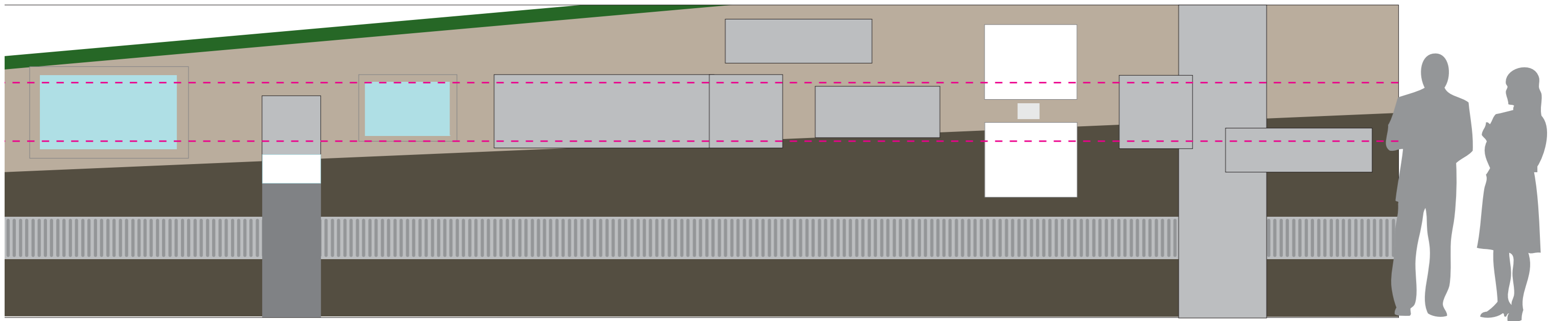
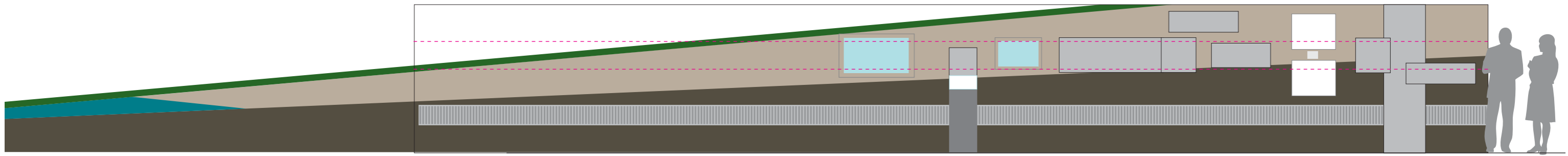

## Graphic Direction

131\_MM\_WPEXH / Whitwoth Park: Pleasure, Play and Politics

# Graphics and aesthetics: Wall 2

## Zone 1: Introduction

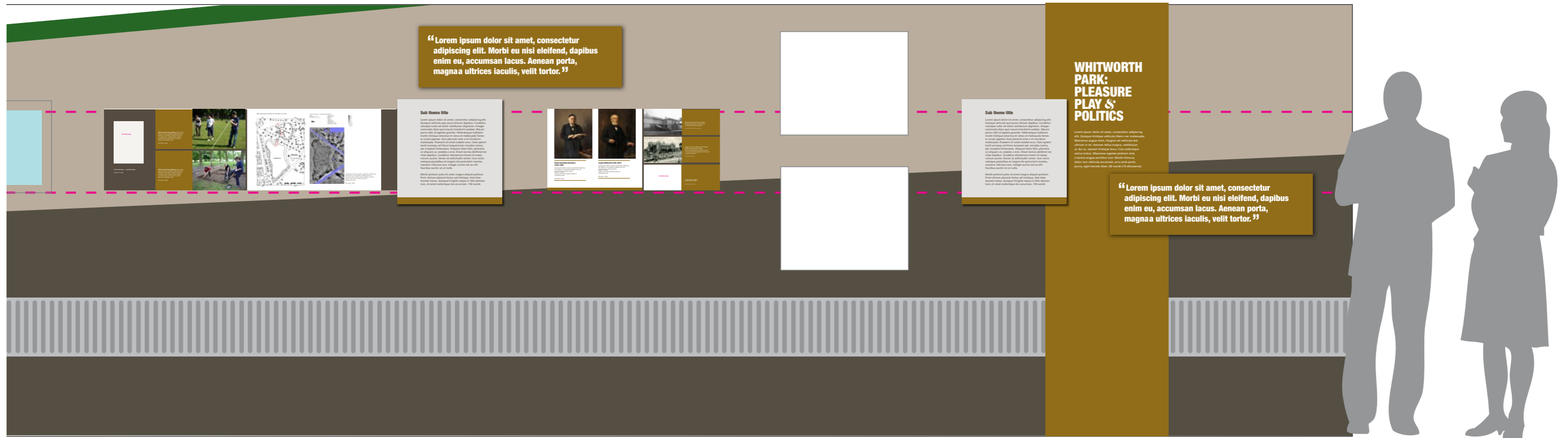

### Graphic Direction

131\_MM\_WPEXH / Whitwoth Park: Pleasure, Play and Politics

# Graphics and aesthetics: Wall graphics zone 1

## Content panels (various sizes)

Image and copy is combined to create engaging, cohesive, accessible content; avoiding multiple panels which could prove overwhelming for visitor

## Design & layout

Nod to formal park theme (geometric, flowerbeds, paths) provides structure for visualising multiple types of image and copy

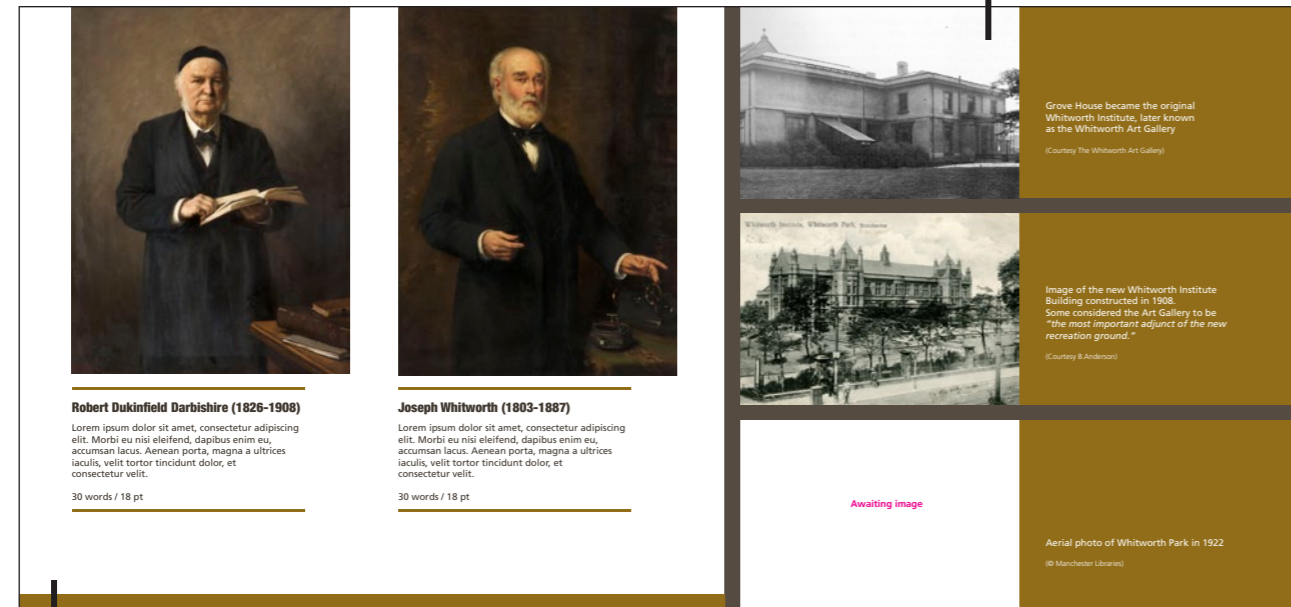

## Labels

Titles....to be discussed  
Bodycopy 18pt

# Robert Dukinfield Darbishire (1826-1908)

Lorem ipsum dolor sit amet, consectetur adipiscing elit. Morbi eu nisi eleifend, dapibus enim eu, accumsan lacus. Aenean porta, magna a ultrices iaculis, velit tortor tincidunt dolor, et consectetur velit.

## Graphic Direction

131\_MM\_WPEXH / Whitwoth Park: Pleasure, Play and Politics

## Main zone panels

Full length (where possible);  
either 2130mm or 1880mm  
colour coded and eye-catching

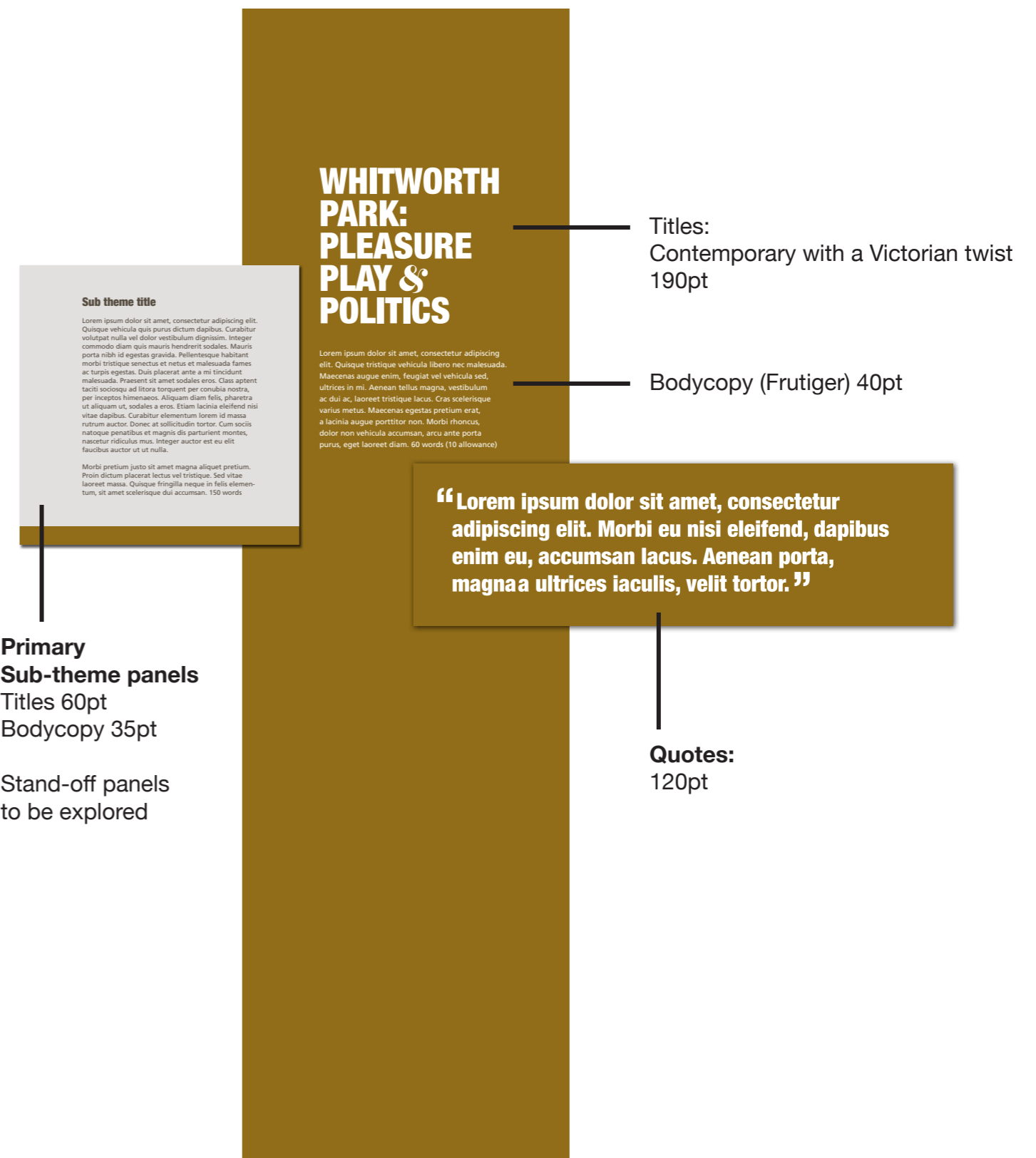

# WHITWORTH PARK: PLEASURE PLAY & POLITICS

Titles:  
Contemporary with a Victorian twist  
190pt

Bodycopy (Frutiger) 40pt

“Lorem ipsum dolor sit amet, consectetur adipiscing elit. Morbi eu nisi eleifend, dapibus enim eu, accumsan lacus. Aenean porta, magna a ultrices iaculis, velit tortor.”

Quotes:  
120pt

## Primary Sub-theme panels

Titles 60pt  
Bodycopy 35pt

Stand-off panels  
to be explored

# Graphics and aesthetics: Wall graphics zone 2

## Content panels

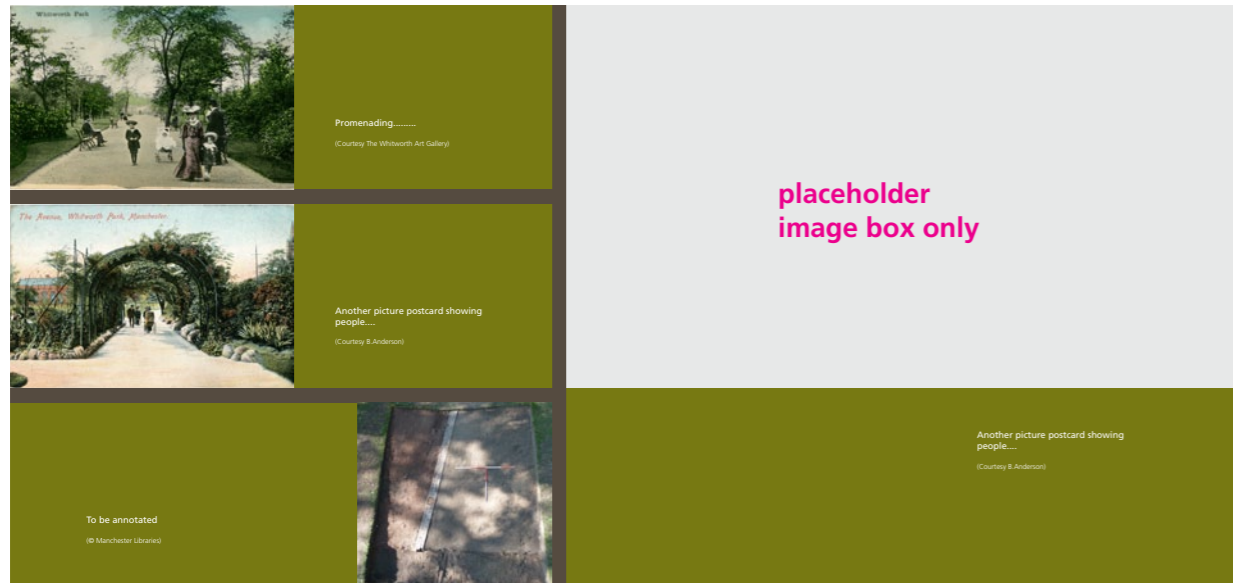

**Main zone panels**  
Full length (where possible);  
either 2130mm or 1880mm  
colour coded and eye-catching

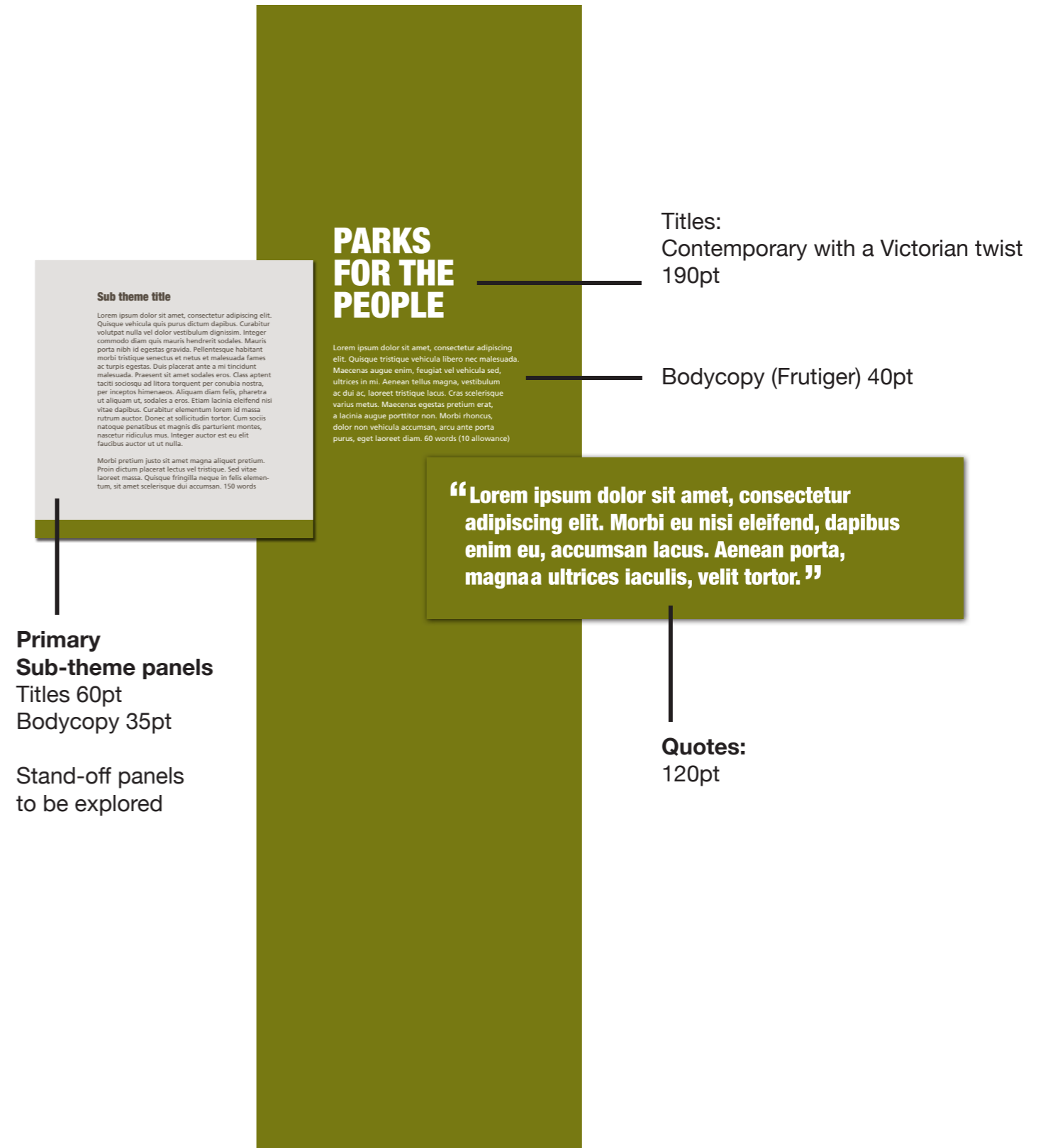

## Graphic Direction

131\_MM\_WPEXH / Whitwoth Park: Pleasure, Play and Politics



# Graphics and aesthetics: main zone panels 1-7



## Graphic Direction

131\_MM\_WPEXH / Whitwoth Park: Pleasure, Play and Politics

## Graphics and aesthetics: planters and objects in focus

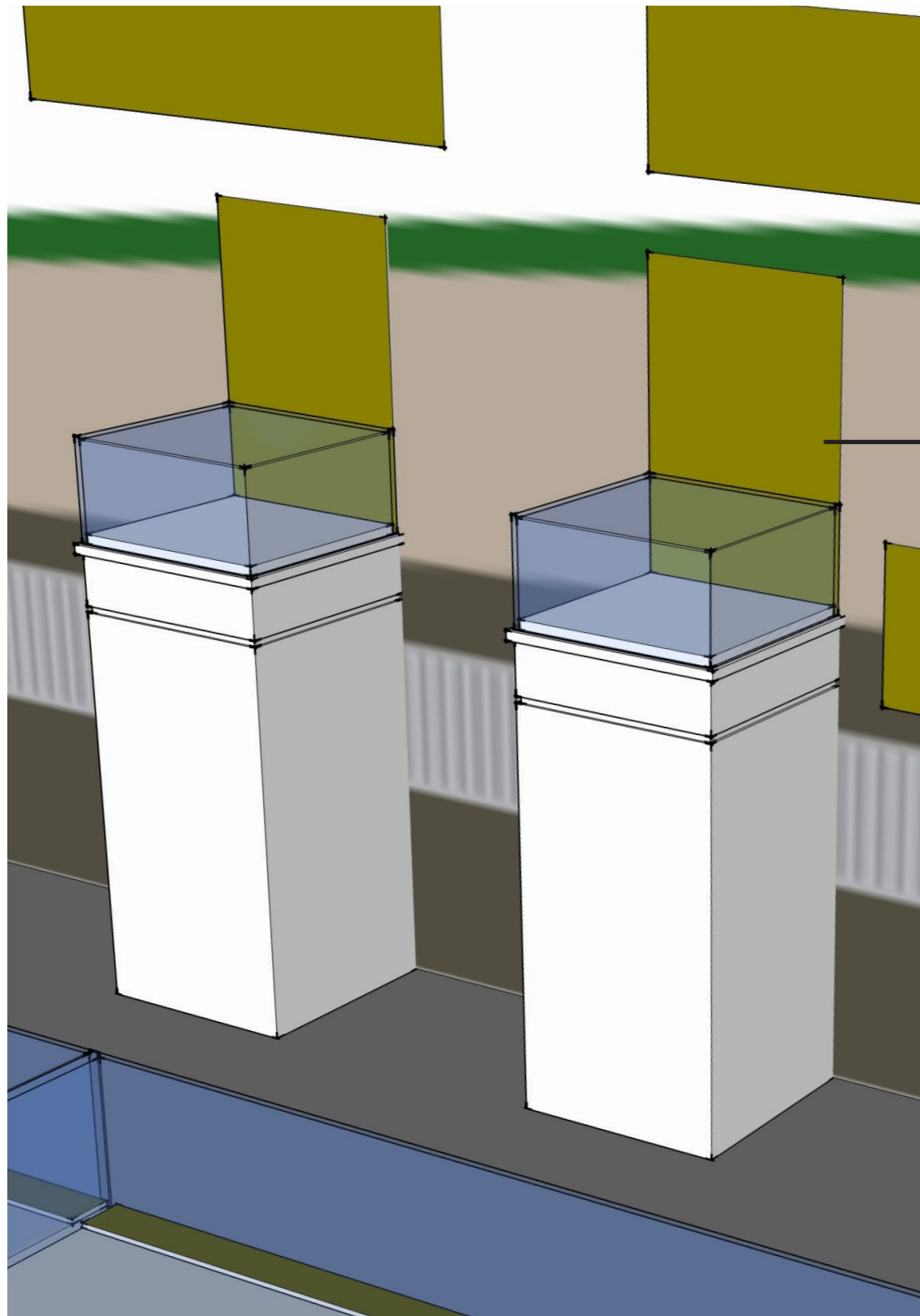

**Object in focus panels (OIFs)**  
Titles 50pt  
Bodycopy 30pt

### Title for object in focus here

Lorem ipsum dolor sit amet, consectetur adipiscing elit. Suspendisse elit massa, volutpat sit amet velit vel, luctus hendrerit ante. Vivamus eget placerat elit. Nam vulputate tincidunt nibh, vitae placerat dolor tempus in. Quisque neque odio, aliquet in porta in, ultricies a nibh. Nulla mattis, risus non fringilla varius, ligula ante vestibulum nisi, eu suscipit dui nunc posuere massa. Phasellus sagittis ultricies commodo. Aliquam et neque sed neque adipiscing scelerisque quis eu magna. Aenean non interdum.  
75 words

**OIFs** add splashes of colour while allowing case base to remain white to best showcase objects

This section positioned behind acrylic case

## Built elements: central unit (1)

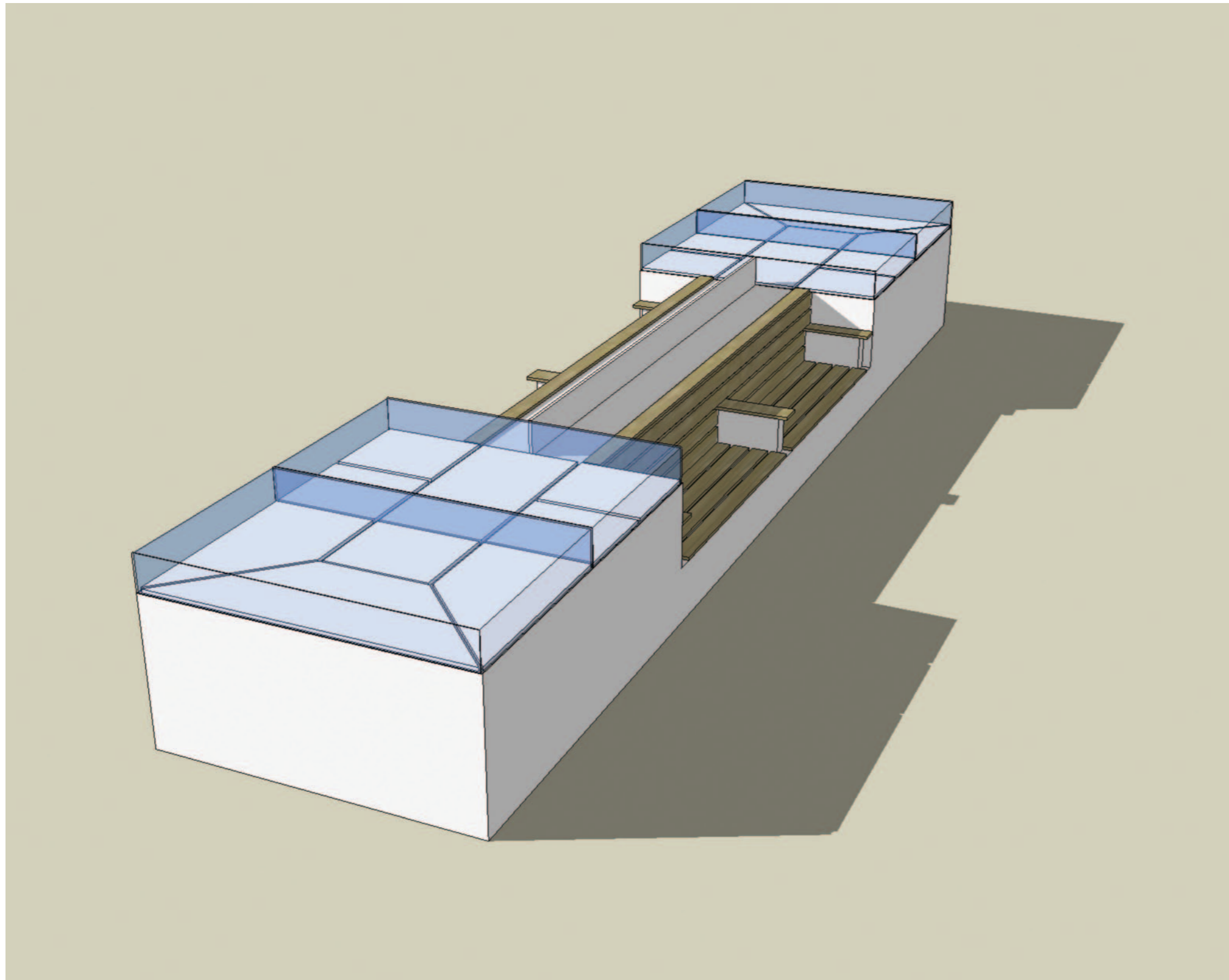

### Central unit

Optimum viewing heights observed  
Combined seating and object display

(In progress/discussion with technical  
services team)

## Built elements: central unit (2)

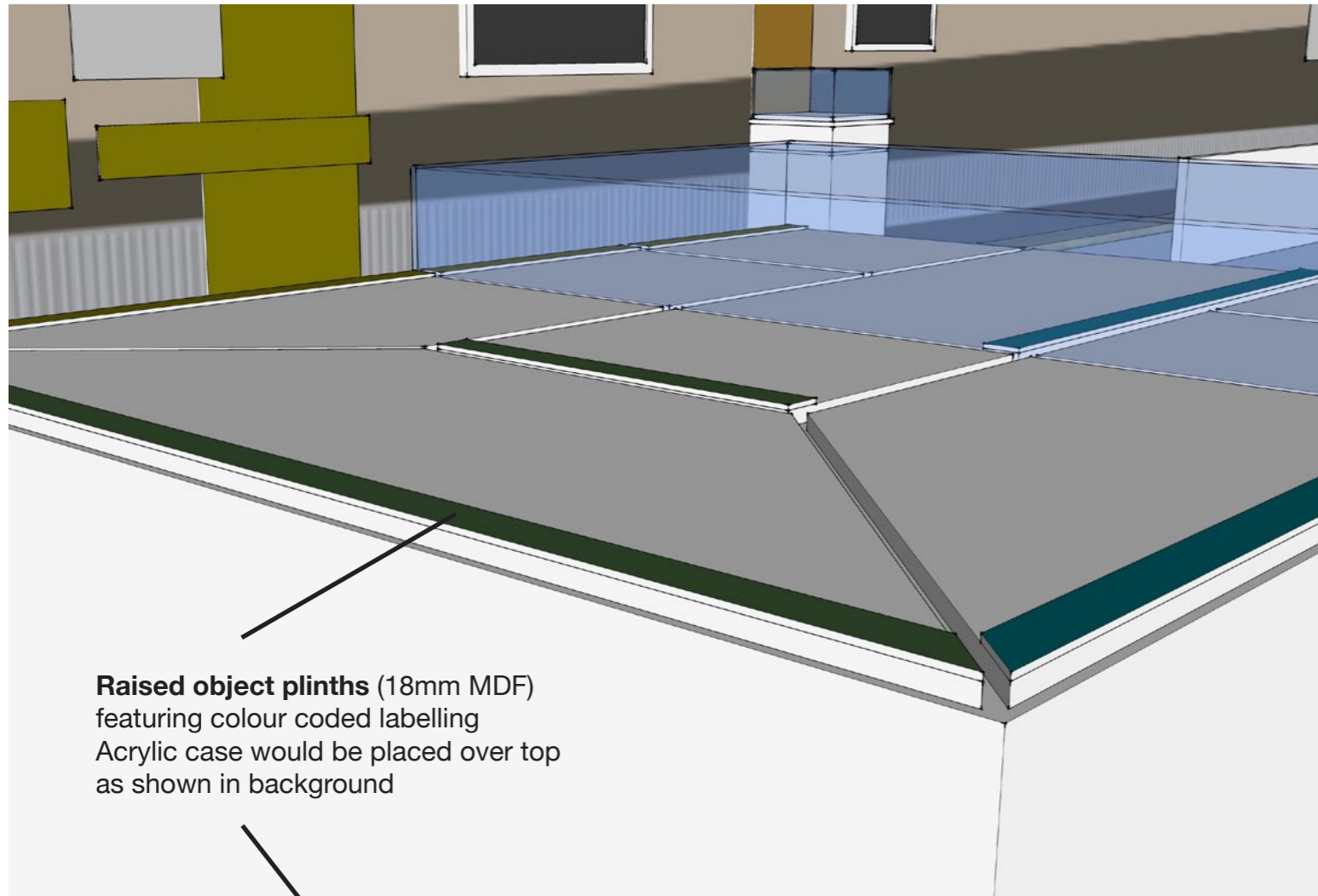

**Raised object plinths** (18mm MDF)  
featuring colour coded labelling  
Acrylic case would be placed over top  
as shown in background

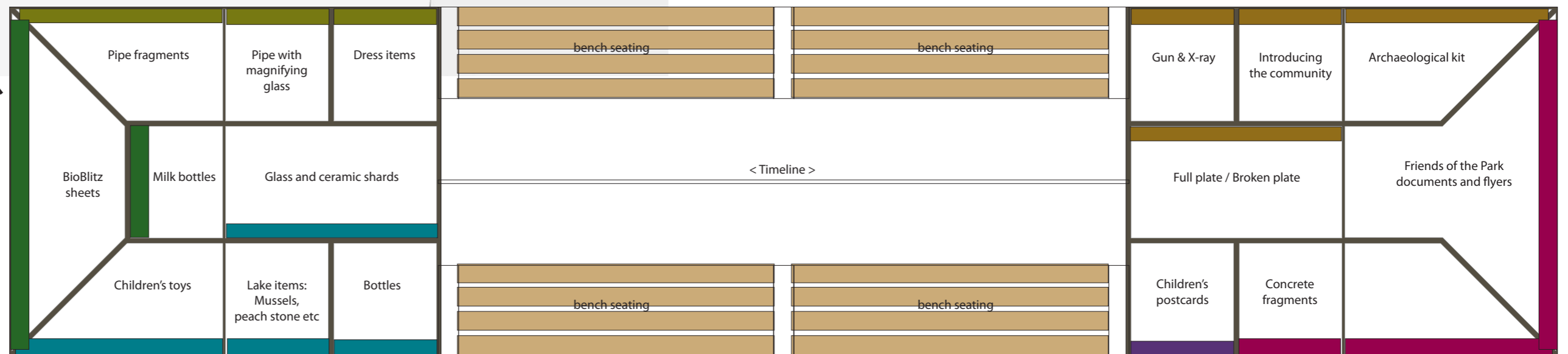

### Graphic Direction

131\_MM\_WPEXH / Whitwoth Park: Pleasure, Play and Politics

## Graphics and aesthetics: central unit labelling

**1**  
Flier in response to Car Park planning application  
(Courtesy of Ken Shone)

**2**  
A letter from the Director of Art Gallery inviting Moss Side residents to a public meeting that led to the Formation of Friends of Whitworth Park  
(Courtesy of Ken Shone)

**Object labels**  
Numbers (where required): 20pt  
Bodycopy 18pt

**1**  
Flier in response to Car Park planning application  
(Courtesy of Ken Shone)

**2**  
A letter from the Director of The Whitworth Art Gallery inviting Moss Side residents to a public meeting that led to the Formation of Friends of Whitworth Park  
(Courtesy of Ken Shone)

**3**  
Powerpoint show by Julian Tomlin at early meeting told of history but also plans for the future.  
(Courtesy of Ken Shone)

**4**  
In 2008 Friends of Whitworth Park presented proposals for the improvement of the Park. This led to working with the Park Manager on the Management Plan

**5**  
Lorem ipsum dolor sit amet, consectetur adipiscing elit. Morbi eu nisi eleifend, dapibus enim eu, accumsan lacus. Aenean porta, magna a ultrices laculis, velit tortor tincidunt dolor, et consectetur velit. Lorem ipsum dolor.

**6**  
Lorem ipsum dolor sit amet, consectetur adipiscing elit. Morbi eu nisi eleifend, dapibus enim eu, accumsan lacus. Aenean porta, magna a ultrices laculis, velit tortor tincidunt dolor, et consectetur velit. Lorem ipsum dolor.

**1**  
A solid lead toy soldier, a doll's hairbrush and doll's tea set were found. They show how particular games and toys were aimed at boy's and girls with the different roles expected of them in later life very much in mind.

**2**  
Before the commercial production of 'fivestones' or 'Jacks' children would get pig or sheep knucklebones from the butcher to play with, hence the earlier name 'knucklebones'

**1**  
A solid lead toy soldier, a doll's hairbrush and doll's tea set were found. They show how particular games and toys were aimed at boy's and girls with the different roles expected of them in later life very much in mind.

**2**  
Before the commercial production of 'fivestones' or 'Jacks' children would get pig or sheep knucklebones from the butcher to play with, hence the earlier name 'knucklebones'

**3**  
Lorem ipsum dolor sit amet, consectetur adipiscing elit. Morbi eu nisi eleifend, dapibus enim eu, accumsan lacus. Aenean porta, magna a ultrices laculis, velit tortor tincidunt dolor, et consectetur velit. Lorem ipsum dolor.

**4**  
Lorem ipsum dolor sit amet, consectetur adipiscing elit. Morbi eu nisi eleifend, dapibus enim eu, accumsan lacus. Aenean porta, magna a ultrices laculis, velit tortor tincidunt dolor, et consectetur velit. Lorem ipsum dolor.

**5**  
Lorem ipsum dolor sit amet, consectetur adipiscing elit. Morbi eu nisi eleifend, dapibus enim eu, accumsan lacus. Aenean porta, magna a ultrices laculis, velit tortor tincidunt dolor, et consectetur velit. Lorem ipsum dolor.

**6**  
Lorem ipsum dolor sit amet, consectetur adipiscing elit. Morbi eu nisi eleifend, dapibus enim eu, accumsan lacus. Aenean porta, magna a ultrices laculis, velit tortor tincidunt dolor, et consectetur velit. Lorem ipsum dolor.

### Graphic Direction

131\_MM\_WPEXH / Whitwoth Park: Pleasure, Play and Politics



**Built elements: central unit and AV (slideshow and phd film)**

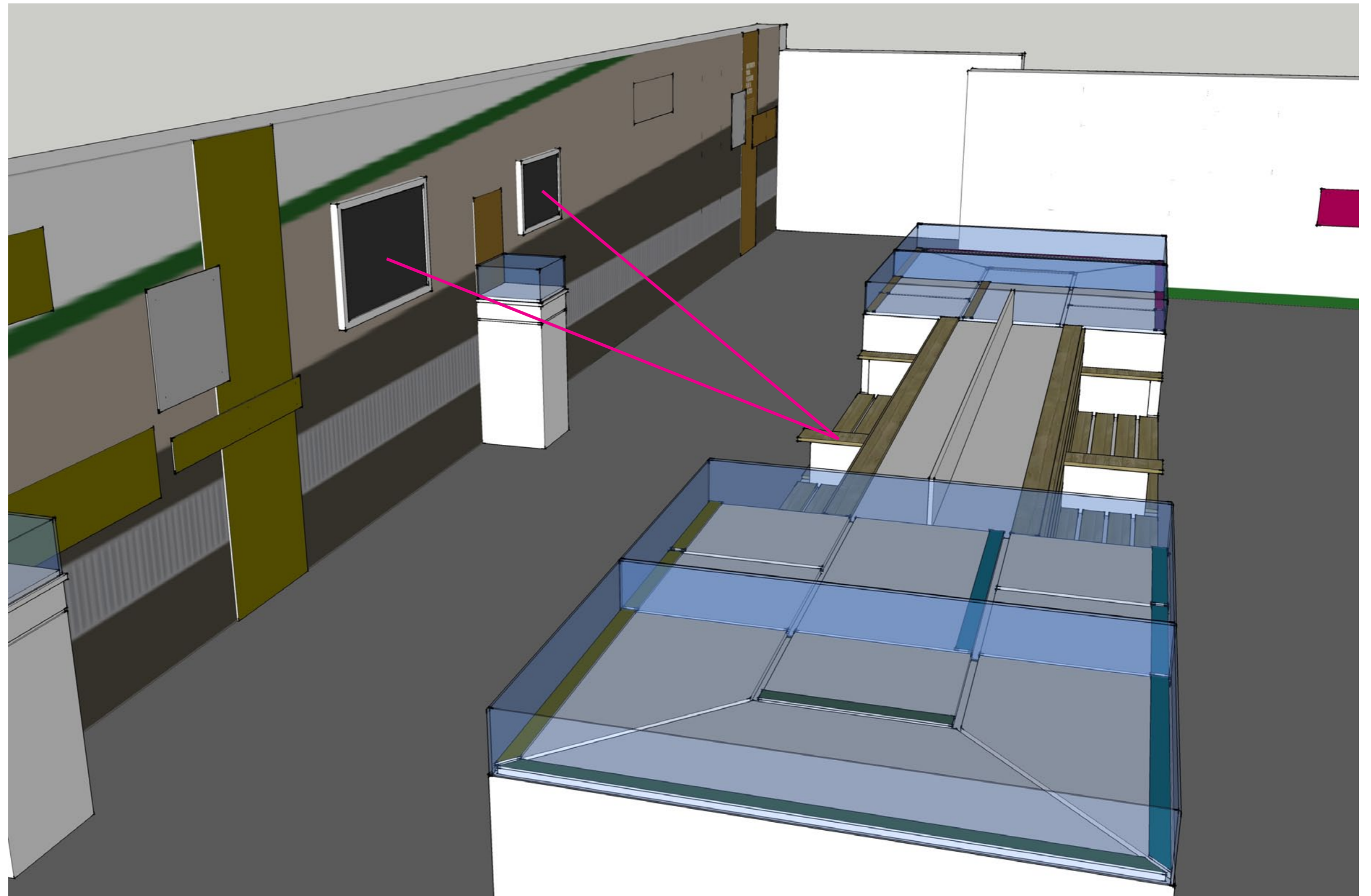

**Seating within sight line of AV**

---

**Built elements: central unit indicating timeline (construction plan only - in progress)**

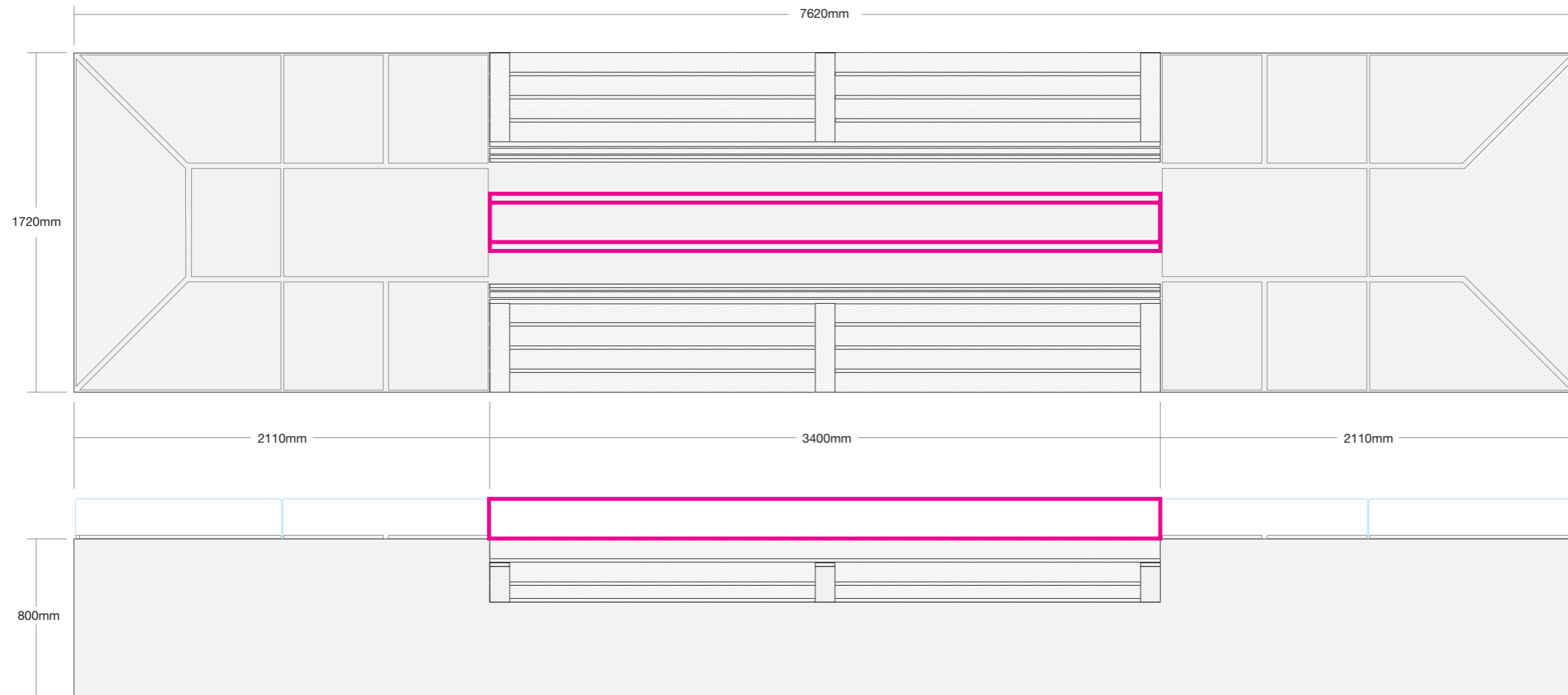

**Timeline within central unit**

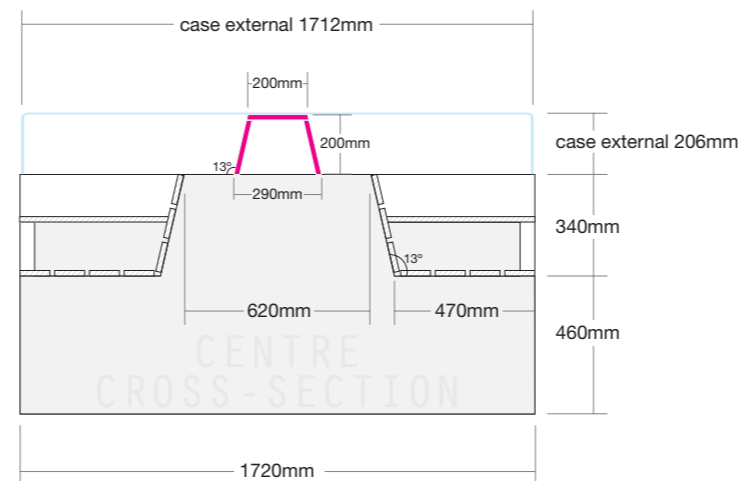
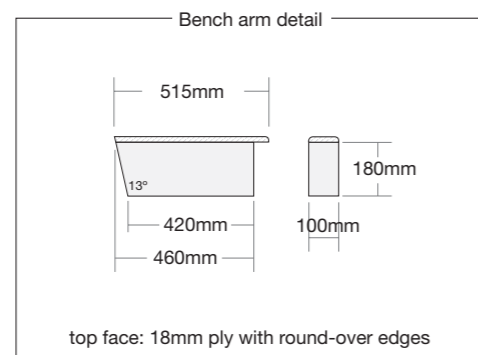

**Graphic Direction**

131\_MM\_WPEXH / Whitwoth Park: Pleasure, Play and Politics

**Built elements: postcard wall (construction plan only - in progress)**

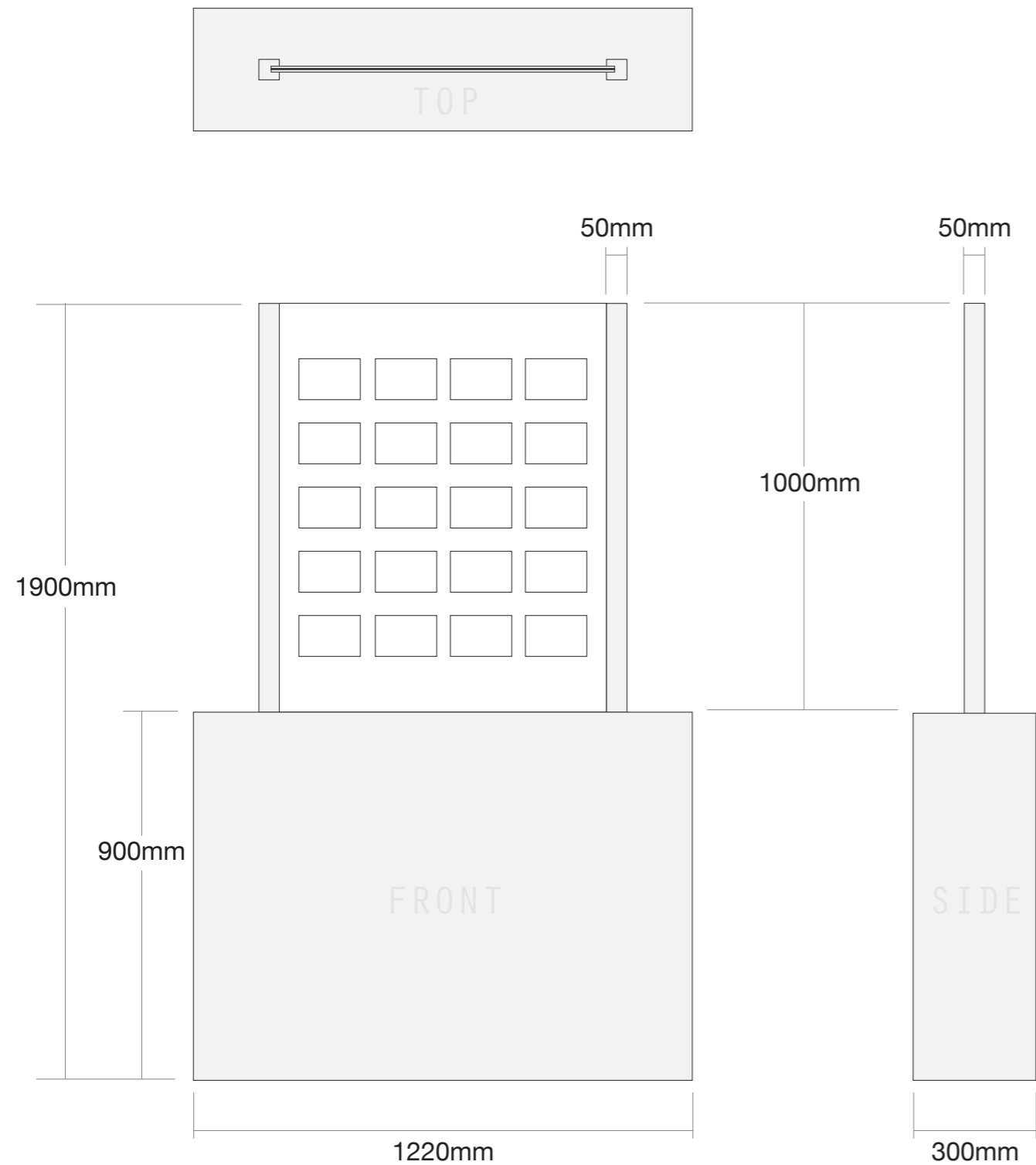

**Postcard wall design**

Construction drawing shows development of postcard display: solid base with acrylic panel housed between uprights (In progress/discussion with technical services team)

