

◆ A medieval moated site at Stretham, near Henfield, West Sussex

Edited by John Funnell

WOODEN REVETMENT by Ray Hartridge

The excavation of a 12 m length of the moat revealed a number of timbers and two partially collapsed, but *in situ*, revetments running east–west, lying on either side of the battered southern wall. A general description of the revetment is given in SAC 147. Additional information concerning the individual timbers is given below. Timber numbers are those given in Figure 11.

Fragments of plank (timber 6) are 1.0 m long and 160 × 90 mm in section, tapered at one end and near the other end a cut for a halving joint with a peg hole. Timber 12 was found with its tenon beneath the base plate of the eastern revetment.

Of five timbers found at the lower levels, but not on the bottom of the moat, one was of similar proportions to the posts of the revetment which had a tenon on one end which would go into the only empty mortise in the western baseplate, another was 240 × 100 mm in section with a bare

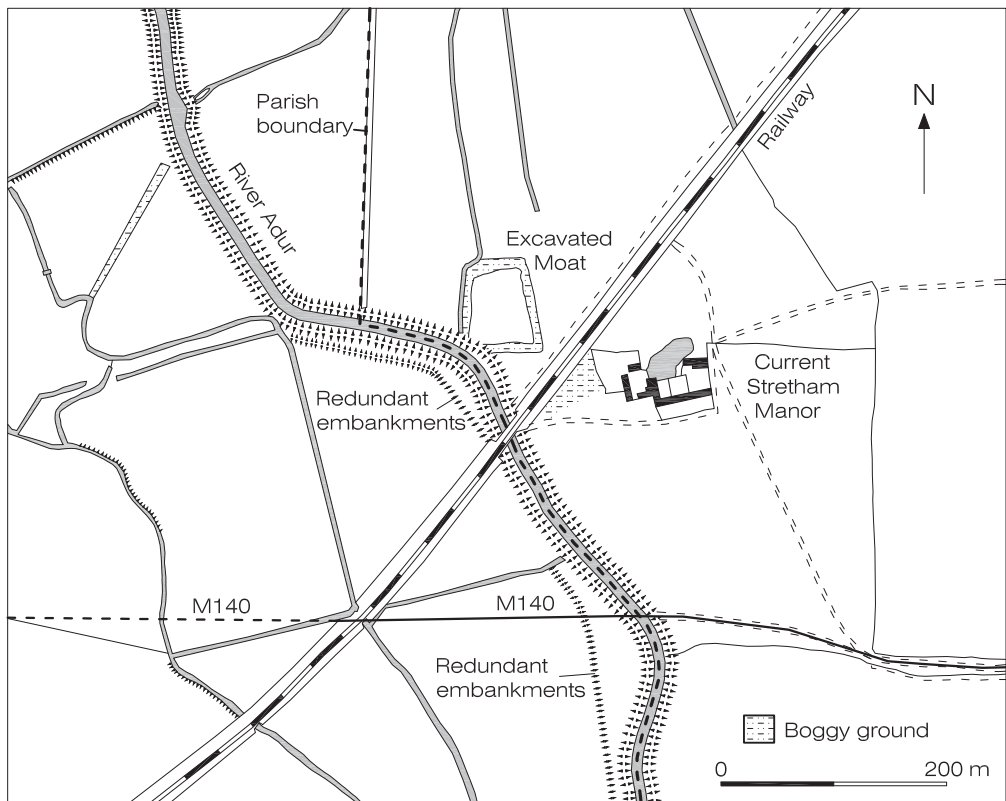

Fig. 2. Map of moated site in 1875 (based on OS 6 in. 1875 52 NW; Henfield, Steyning, Ashurst).

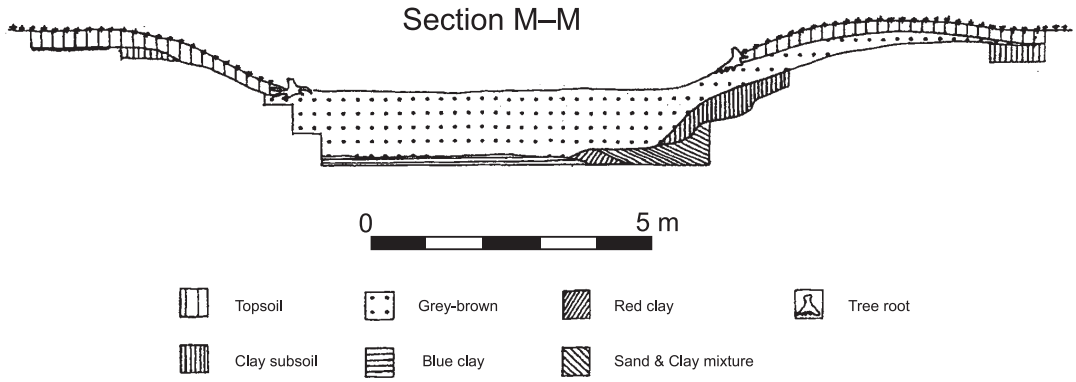

Fig. 5. Section through moat – M-M.

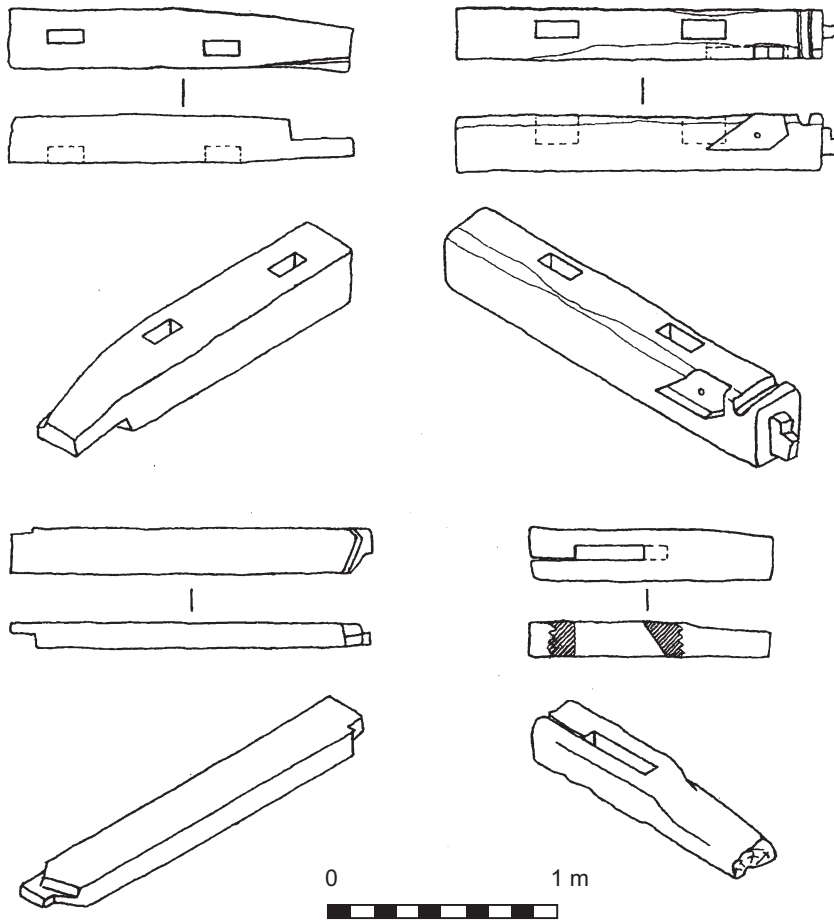

Fig. 13. Typical timbers showing joint arrangements.

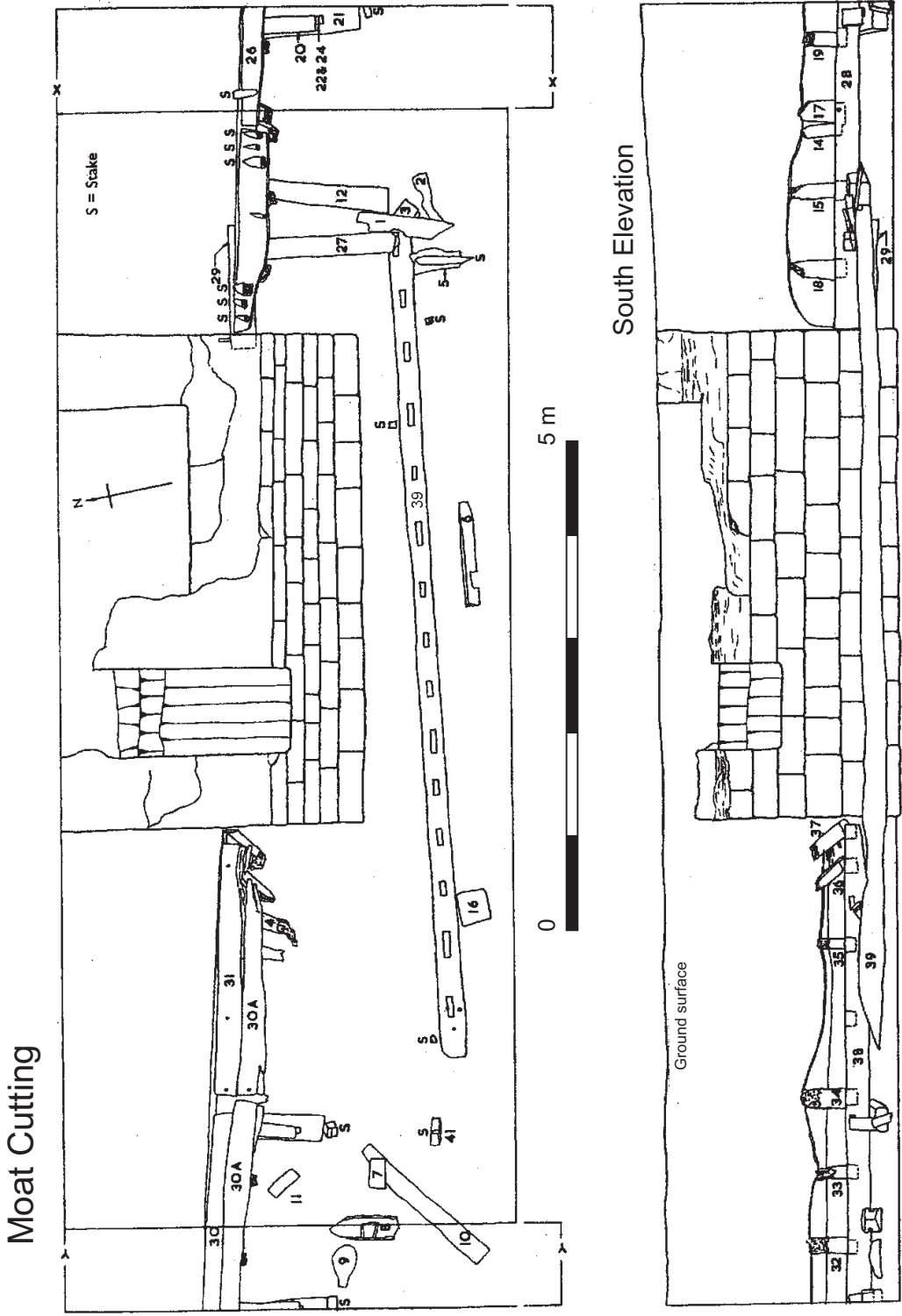

Fig. 11. Plan and elevation of the wooden revetment.

face tenon at one end and one broken off after a length of 260 mm. A third was 135 × 90 mm long and 150 mm square, tapered to a point. A fourth was 135 × 90 mm in section with a groove 30 mm wide and 40 mm deep all along one side. It was tapered at one end to a chisel point and broken off after 420 mm; probably grooved to receive a plank but re-used as a stake. The fifth and most substantial loose timber was 1.57 m long and 240 × 210 mm in section. It had been cut for four joints. On one end was a broken tenon; two mortises were cut out into one face and at 90° to these the face was cut for a matching lap-joint. This was a joint most frequently associated with the period c. 1150–c. 1250 (Hewett 1982). Typical joint arrangements are shown in Figure 13.

DETAILS OF ALL TIMBERS RECOVERED FROM THE MOAT

Numbers refer to those given in Figure 11.

1. Part of a plank 20 mm thick
2. Part of a plank 30 mm thick
3. Chock 450 × 130 × 110 mm
4. Brace 600 × 220 × 140 mm
5. Part of a plank (fragment)
6. Beam 1000 × 140 × 90 mm
7. Plank fragment
8. Beam 720 × 250 × 200 mm (grooved to take planks)
9. Block 450 × 230 mm dia. (part of tree trunk)
10. Plank 1630 × 400 × 20 mm
11. Plank 350 × 150 × 15 mm
12. Beam 1500 × 250 × 200 mm (mortise and tenon)
13. Beam 450 × 135 × 110 mm (with tenon end)
14. Beam 450 × 135 × 120 mm (with tenon end)
15. Base 430 × 150 × 120 mm
16. Chock 360 × 270 × 270 mm
17. Beam 410 × 190 × 140 mm
18. Beam 560 × 175 × 120 mm (tenon one end with peg hole)
19. Beam 560 × 1750 × 120 mm
20. Brace 750 × 200 × 125 mm
21. Beam 1320 × 340 × 170 mm (mortise with tenon 21 and 22 in opening)
22. Wedge 330 mm long (driven into moat bottom)
23. Stake (driven into moat bottom, left in place)
24. Wedge 330 mm long (driven into moat bottom)
25. Plank fragment
26. Plank fragment
27. Beam 1550 × 190 × 110 mm tenon at both ends)
28. Beam 3330 × 250 × 250 mm (mortise at both ends)
29. Beam 1170 × 270 × 270 mm (mortise in two places with peg still in position one end)
30. Plank 1870 × 305 × 30 mm
31. Plank 2600 × 280 × 20 mm (with three peg holes)
32. Beam 630 × 180 × 140 mm (tenon one end)
33. Beam 680 × 150 × 140 mm (tenon one end)
34. Beam 750 × 200 × 130 mm (tenon one end)
35. Beam 680 × 150 × 150 mm (tenon one end)
36. Beam 700 × 130 × 130 mm (tenon one end)
37. Beam 620 × 150 × 130 mm (tenon one end)
38. Beam end 1080 × 250 × 200 mm (mortise three places had been cut off)
39. Beam end 8550 × 250 × 250 mm (fifteen mortise slots, two places with three pegs)
40. Plank fragment (from east of stone structure)
41. Beam end 1300 × 220 × 110 mm (shaped as possible stake)
42. Beam 1570 × 240 × 210 mm (mortise two places and with unbroken tenon)
43. Stake? 940 × 150 × 150 mm
44. Beam fragment 960 × 250 × 100 mm
45. Beam 500 × 95 × 95 mm (with tenon and peg hole)
46. Beam 1050 × 230 × 140 mm (one mortise hole with split through to end)
47. Block 410 × 135 × 90 mm? (containing grove for planking)

THE POTTERY by Mark Gardiner

Editor's note: Owing to the passage of time, some of the pottery described, and its associated illustrations, have been lost and therefore certain drawings referred to in the text, and, marked with an asterisk, cannot be included.

Fabrics

Some of the fabric descriptions have already been published and reference should be made to Gardiner (1990, 255) and (1994, 46–8). The fabric series is based upon the work by Streeten and has been augmented and modified as necessary

with the omission of some fabric numbers. Full fabric descriptions are given below where they have not been given in the earlier publications, otherwise they are given in summary form and a representative range of the vessels illustrated.

Saxo-Norman fabrics

Fabric 1 - Coarse angular white flint, sparse sand and some mica.

- P1. Rim from cooking pot. Context X/14.*

Fabric 2 - Same as Adur Valley DH, for which see Gardiner (1990, 225).

- D. Rim from cooking pot with pie-crust decoration Building D (Fig. 14, no. 1).
- L. Stabbed rim sherd from cooking pot. Context C7 (Fig. 14, no. 2).

Fabric 26 - Same as Adur Valley DA, for which see Gardiner (1990, 253).

Fabric 33 - Same as Adur Valley DK, for which see Gardiner (1993, 44).

- O. Base of jug. This is a rare example of a jug in this fabric which seems to represent a development of Fabric DB (Gardiner & Greatorex 1997). Context D1 (Fig. 14, no. 3).

Later medieval local non-white wares

Fabric 3 - Coarse sub-angular sand with sub-angular multi-coloured flint up to 1 mm across.

- M. Cooking pot/bowl with applied bands and stabbed rim. Context P15(1) (Fig. 14, no. 4).
- P4. Cooking pot with stabbing. The vessel is unusual in that the stabbing has been made from under the rim. 'Area A/6. Trench on inside of wall above grey layer' *

Fabric 5 - Coarse sub-angular sand and broken shell fragments.

- P12/E. Tall bowl or cooking pot with stabbed rim. Compare with similar vessels from Hangleton (Smith and Hurst 1963, 118, nos 45-6, 48). Context K4(1) (Fig. 14, no. 5).
- P7. Tall bowl or cooking pot with stabbed rim and body. Area A2.*
- P31. Rim of cooking pot with coil-built body and wheel-turned rim with applied ribs. 'Moat B gravel, E end' (Fig. 14, no. 17).
- N. Rim of cooking pot/bowl Context D5 (Fig. 14, no. 6).

Fabric 6 [Steinyng Coarse Sandy micaceous ware (SCSm)] - Coarse sub-rounded sand with some larger quartz inclusions and some mica.

- C. Small vessel of unknown function, comparable with a similar pot from Seaford (Machling 1995, 205, fig. 13, no. 6). Context M19(2) (Fig. 14, no. 7).
- P14. Rim of cooking pot with applied straps. 'Kiln ditch, 530-610 mm'.*
- P18. Bowl, coil-built and finished on tournette or wheel. Sooting on outside of base, sides and below rim. Sooting at the centre of the base has worn away. 'Resting on natural immediately behind wood revetment. E.*

Fabric 7 [Steinyng Coarse Sandy ware (SCS)] - Similar to Fabric 6, but without mica.

- F. Rouletted and wavy incised line decorated cooking pot or ovoid jug. Rouletting is uncommon in Sussex and may reflect the influence of French pottery. Context C11, C12 (Fig. 15, no. 8).
- G. Rouletted decorated rim. Context L14(2) (Fig. 15, no. 9).

- P8. (not illustrated) Bowl with internal glazing similar to Gardiner and Greatorex (1997, 165, fig. 15, no. 16).
- P16. Cooking pot with distinct flange. The wheel-turned rim has been joined to a less regular body possibly made on a tournette. Context 7/60/1.*
- P58. Cooking pot with sharply everted rim and crude, splash glaze. Context P15(1) 470 (Fig. 16, no. 18).

Fabric 8 - Medium sand and occasional iron ore flecks and mica.

- H. Jug base with holes drilled from the exterior after firing. This pot was adapted, perhaps to serve as a watering pot. Purpose-made watering pots are known, for example, from London (Pearce *et al.* 1985, fig. 77). Context 'MW' (Fig. 15, no. 10).

Fabric 9 - Fine grey or translucent sand.

Fabric 10 - [Steinyng Medium Sandy ware (SMS)] - Sub-rounded clear coarse sand.

- P27. Body sherds from jug with sgraffito decoration. Contexts IA8/62, IA10/62.*

Fabric 28 - Abundant coarse sand and common mica.

Fabric 29 - Coarse sub-angular sand, grog and some mica.

Fabric 30 - Abundant medium to coarse sand with large white sub-angular quartz inclusions.

Fabric 31 - Abundant fine grey sand with occasional larger quartz grains.

Fabric 32 - Light brown surfaces, grey or brown margins and core. Hard, slightly rough fabric with hackley fracture. Contains 2% iron ore up to 0.25 mm across and 0% unsorted angular white or grey flint up to 1.5 mm across.

- A. Low bowl or skillet with sooting on exterior and thick olive green glaze on base of interior. Contexts H2(1), H3(2) (Fig. 15, no. 11).
- B. Cooking pot/bowl with external sooting. Moat 'black gravel' (Fig. 15, no. 12).

Later medieval local white wares

Fabric 12 - Abundant grey medium sand.

- I. Jug or cistern with everted rim glazed internally, pierced before firing for tie-down cover? Context H5 (2) (Fig. 15, no. 13).

Fabric 13 - Abundant sub-angular fine sand, occasional grog flecks.

- P35. Boss from lid. Cf. Holden (1963, 122, fig. 22, nos 144-5). Context M19(2)/35.*

Fabric 14 - Abundant fine to medium grey sand, occasional angular ironstone and grog.

- P50. Rim from glazed jug with stamped and applied decoration around rim. Barton (1979, 115, no. 12) illustrates a similarly decorated vessel which he describes as anthropomorphic. In the present vessel the stamps may have been intended to resemble eyes with a nose between. Contexts L3(2), M15, edge of BD, M4(1) (Fig. 16, no. 19).

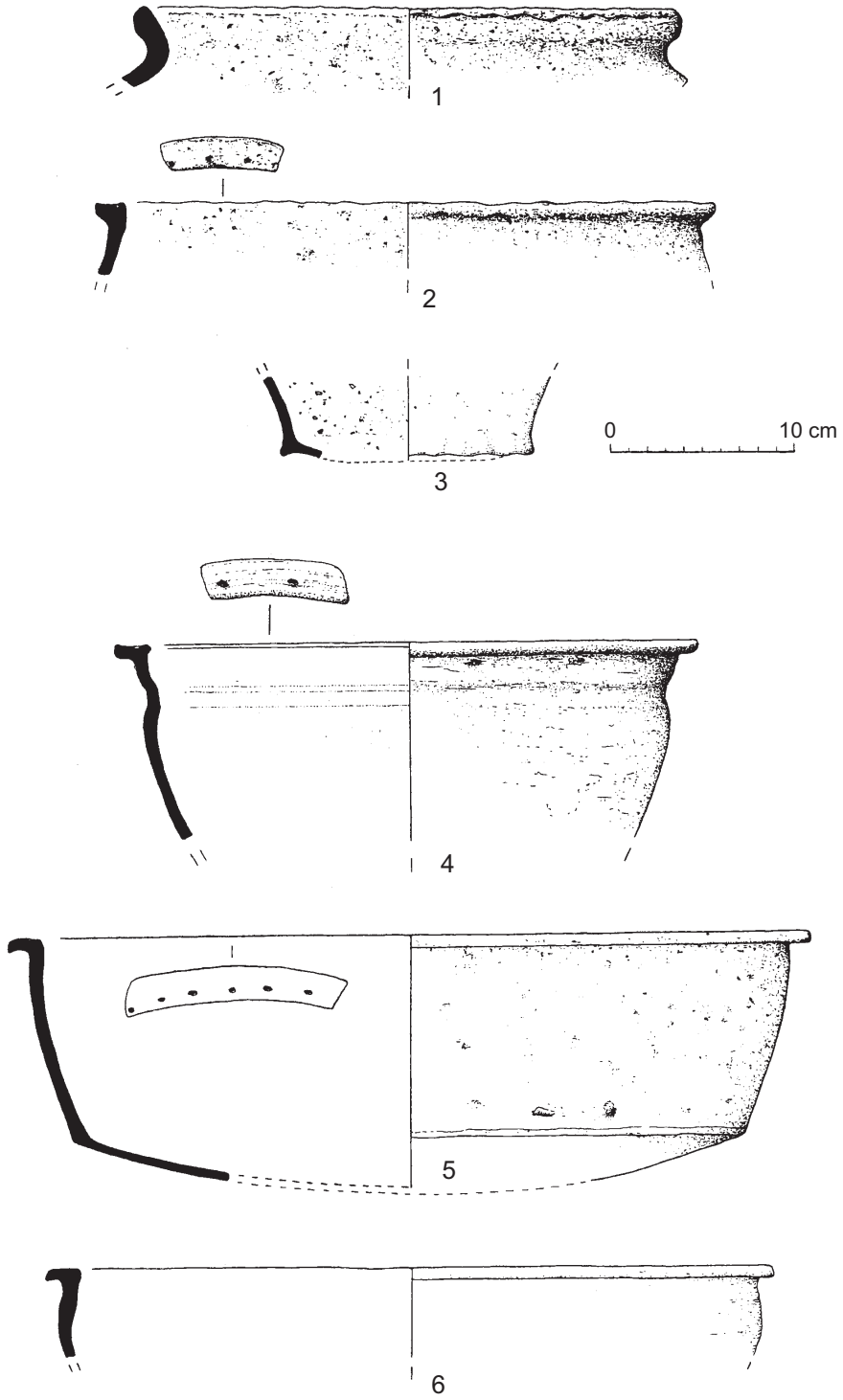

Fig. 14. Pottery 1-6.

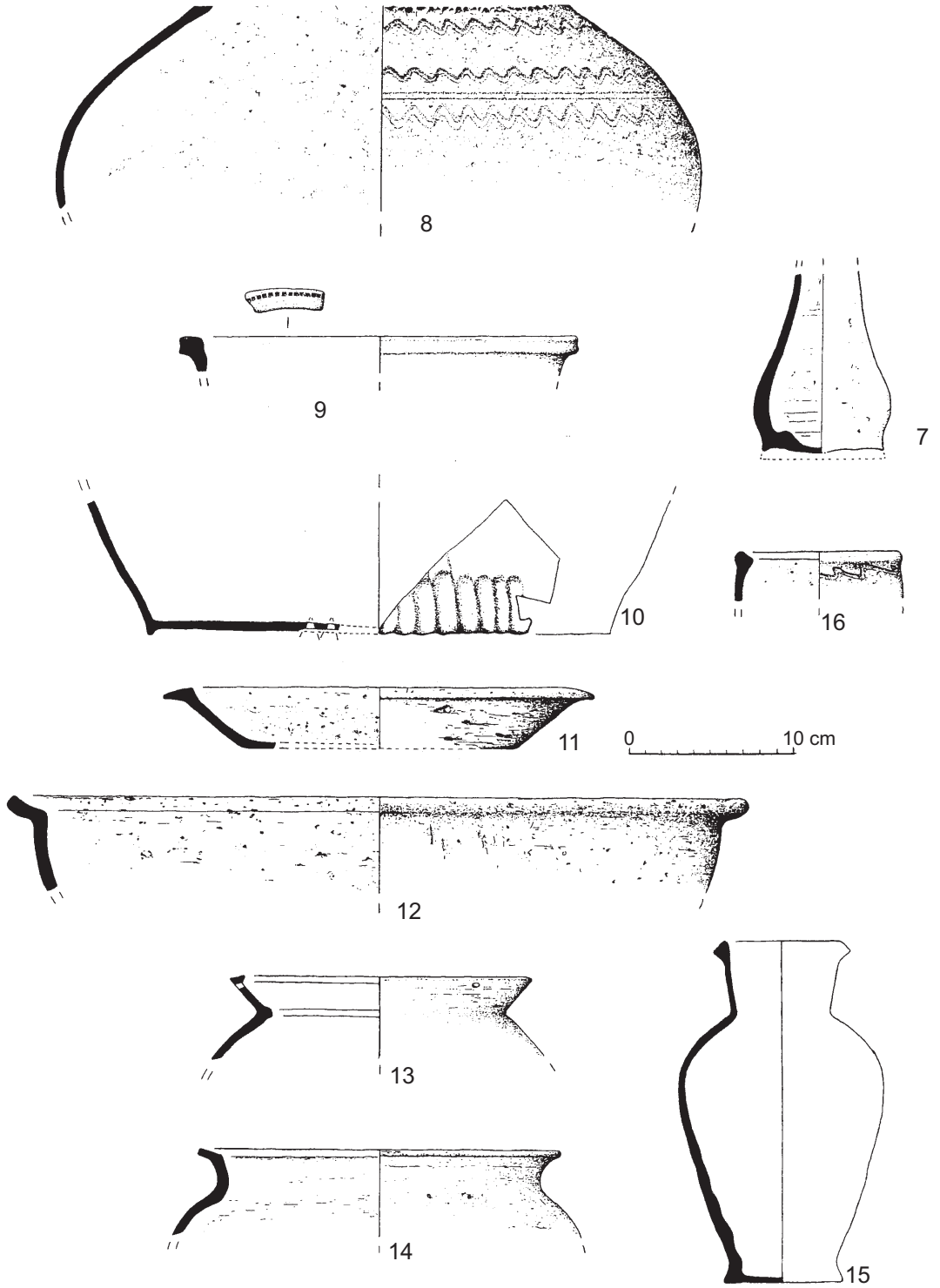

Fig. 15. Pottery 7-16.

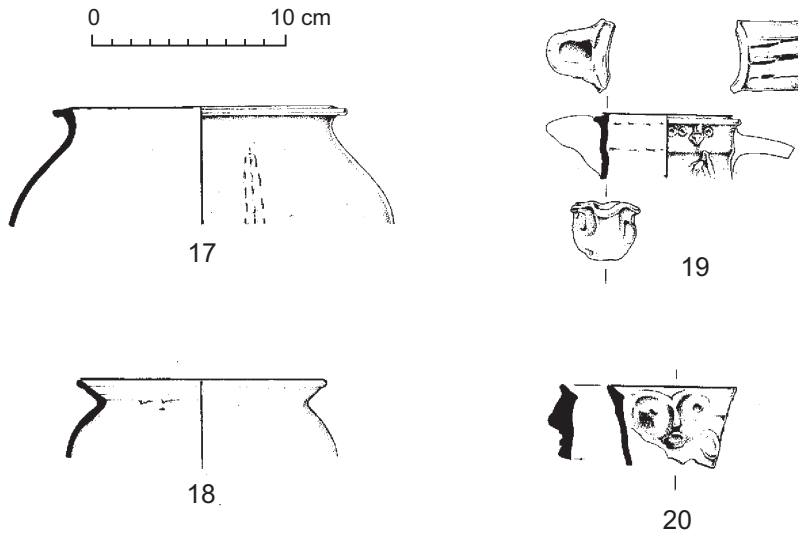

Fig. 16. Pottery 17-20.

Fabric 16 - Fine to medium grey sand, usually glazed

- Q. Cooking pot. Context A5 (Fig. 15, no. 14).
- P47. Face-on-collar jug. cf. Barton (1979, 114, no. 1 - top left). Context F, 'on chalk of E. wall' (Fig. 16, no. 20).
- P49. Applied decoration in the form of a hand from an anthropomorphic jug. There are no close local parallels, although a Lewes Friary jug with projecting arms has hand decoration (Gardiner *et al.* 1996, fig. 23, no. 3). This vessel was rather different since there were clearly no projecting arms. Context 32/60.*

Non-local English wares

Fabric 18 - Rye Ware.

Fabric 19 - Red surfaces, grey margins and core. Soft fabric, slightly coarse to feel. Very common medium to fine grade sand with frequent fine flecks of iron ore. Probably from Earlswood kilns (Turner 1974).

- J. Rim sherd with white slip under green glaze and decorated with sgraffito. Fabric 19. Context C7 (Fig. 15, no. 16).

Fabric 21 - Scarborough Ware

- K. (not illustrated). Body sherd from jug with horizontal rouletted decoration. Context P14(1).

Imports

Fabric 23 - Dutch slipware.

Fabric 24 - White faces and margins, light grey core. Hard, moderately smooth fabric with sharp fracture. Occasional red or grey fine sand grains. South-west French white ware.

Fabric 25 - Pink-orange margins and surfaces, grey core. Hard, moderately smooth fabric with sharp fracture. Common fine sand quartz, 0.5% medium grey sand quartz. Source not identified.

Fabric 34 - White faces and core. Smooth texture with rough fracture. Tempered with very fine sand and 0.5% chalk up to 1 mm across. Source not identified. Only a single vessel in this fabric was identified.

- P. Jug glazed internally and externally with a dark green coat. Context moat 'black gravel, east end' (Fig. 15, no. 15).

METALWORK

Bronze or copper alloy (Fig. 17)

1. Part of the casting with two rivets still in position.
2. A small plain ring.
3. A three-pronged casting with the stem broken off after 600 mm. A similar pricket-candlestick in the London Museum, dated to the early fourteenth century, has three folding legs, these have been broken off the Stretham example. The central pricket would hold a candle and it is suggested that the ring-socket is intended to hold a rush-light. The function of the V-shaped projection is not known.
4. A piece of decorative arcading broken off at the centre of the second arc.
5. A hollow conical object broken off at the wider end; probably a candle snuffer.
6. Metal fitting.
7. Metal fitting.

Iron (Fig. 18)

1. A much corroded rod, probably square throughout originally. Perhaps a window bar.
2. A wedge suitable for splitting wood.
3. A hook suitable for use as a pot hook.
4. Part of a spur.
5. Horseshoe.
6. Nail.
7. A short stubby arrow head with socket. Similar to one from Lodsbridge Mill at Lodswoth (Holden 1967, 124) was dated thirteenth century.
8. Key.

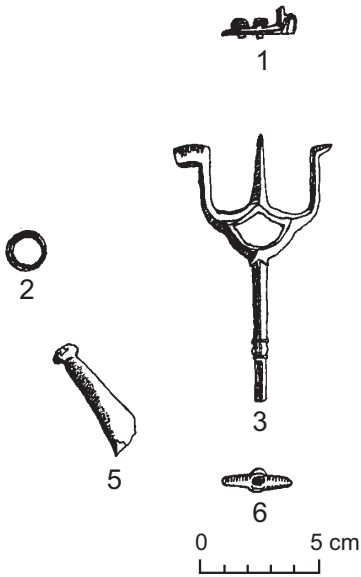

Fig. 17. Metalwork – copper alloy: 1, 6 & 7 - fittings; 2 - ring; 3 - pricket; 4 - portion of book clasp; 5 - snuffler.

Items not illustrated:

- A key.
- A short stubby arrow head with socket. Similar to one from Lodsbridge Mill at Lodswoth (Holden 1967, 124) was dated thirteenth century.
- A hook suitable for use as a pot hook.
- A corroded rod, probably square throughout originally. Perhaps a window bar.
- Part of a spur.
- A wedge suitable for splitting wood.

TILE AND SLATE by E. W. Holden
Details of tiles and slates

No.	Type	Provenance
1	? Plain ridge tile	South of H
2	? Plain ridge tile	Ditto
3	Crested light	3 'Scoop well'
4	Green-coloured glaze	Ditto
5	Green-coloured glaze	Ditto
6	Green-coloured glaze	East of F
7	Green-coloured glaze	North of J
8	Green-coloured glaze	Feature J
9	Green-coloured glaze	East of F
10	Green-coloured glaze	3 'Scoop well'
11	Green-coloured glaze	Over building B
12	Green medium glaze	West of building E
13	Crested darker green	South of building E
14	Crested darker green	Near domestic hearth

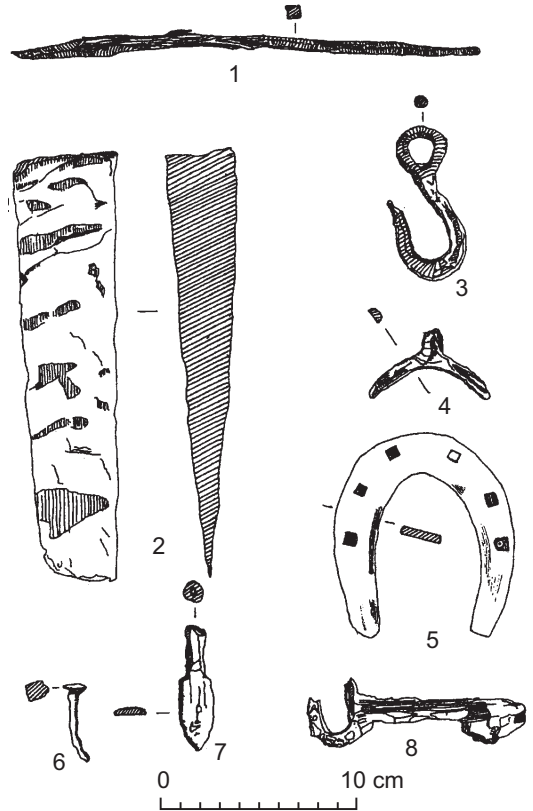

Fig. 18. Metalwork – iron.

No.	Type	Provenance
15	Crested darker green	Southwest of E
16	Crested darker green	Ditto
17	Crested darker green	C14 cobbles north of E
18	Crested darker green	West of J
19	Crested darker green	East of F
20	Crested darker green	Ditto
21	Slate, grey-black	Cobbles north of J
22	Slate, grey-black	Ditto
23	Slate, grey-black	Area J
24	Slate grey	Inside F
25	Grey/olive green	Area G
26	Slate green	J, A, B & H
27	Plain floor tile	
28	Oven tile	
29	Oven tile	Between F & J
30	Oven tile	East of B & E
31	Oven tile	

No.	Type	Provenance
32	Two Singleton OAM Crested Ridge Tiles	Southwest of E
33	Two Singleton OAM Crested Ridge Tiles	Between G working floor & F
34	Plain roof tile	West of H & J
35	Plain roof tile	Between B & E
36	Plain roof tile	Northeast of F
37	Plain roof tile	West of H & J
38	Plain roof tile	West of H & J
39	Plain roof tile	Northeast of F
40	Plain roof tile	East end of B
41	Plain roof tile	No record
42	Plain roof tile	No record
43	Nib tile	Over G 'working floor'

No.	Type	Provenance
44	Nib tile	Feature B, near buttress
45	Nib tile	Ditto
46	Nib tile	Between B & E, H & J
47	Nib tile	Building J
48	Nib tile	Northeast of F
49	Nib tile	West of H & J
50	Pan tile	Building F
51	Post medieval tile?	South of H
52	Crested ridge tile (post medieval?)	Feature 3 'scoop well'
53	Ridge tile frog	North end of F
54	Ridge tile frog	Inside feature F
55	Ridge tile frog	North of E

ACCESS TO THE SITE

by Alan Stevens

BY ROAD

Good road access was required by the bishop, as he moved from Chichester across the diocese, staying in his manors. This section describes passable roads from Amberley Castle, via Stretham, to Bishopshurst, Albourne. In 1374 the bishop was concerned to retain a right of way from Amberley to Stretham (Hudson 1987, 141). This probably used part of the Sussex Greensand Way, Margary 140 (M140) (Margary 1973, 68), approaching Stretham. Roads and paths still exist on the Upper Greensand (UGS) and then Lower Greensand (LGS) from Amberley to join the M140; perhaps at Muttons Farm (TQ 118 149), perhaps further east. In the absence of an engineered causeway, this necessitated a potentially difficult crossing of the Gault clay at any place between Rackham (TQ 0514) (Margary 1965, 180, 6) and paths north of Steyning. From Muttons Farm to the river crossing at Stretham, M140 or nearly parallel tracks along the LGS ridge may still be found.

Going eastward from Stretham, the next episcopal manor was probably at Bishopshurst, Albourne (c. TQ 265 163), though its site is not known precisely (Hudson 1987, 127). This lies 1 km north of M140, joined to it by a lane from 100 m east of Coldharbour Farm (TQ 260 150). But this is on the Gault clay. Bishopshurst, however, stood on the ancient track on LGS running east

from Henfield church. The M140 is still in use, or closely paralleled from Stretham to the LGS ridge at TQ 240 143; including a stretch of 2 km across Weald Clay, represented mainly by Horn Lane. But the next stretch of 3 km lies across Gault clay and is seldom visible by path or boundary. Margary noted evidence of the road, but his account lacks evidence of repairs or of its continued use (Margary 1965, 174). It was probably replaced by continued use of the LGS ridgeway from near the east end of Horn Lane at (TQ 235 148) to Henfield, causing the little diversion at the junction. Secondly, a short cut could be made by the 'old road' (Hudson 1987, 134), now the A2037 from Woods Mill on M140 at TQ 218 138 north to Henfield. From Henfield, lanes and footpaths still run almost due east on LGS to the site of Bishopshurst.

BY WATER

In 2003 the Normal Tidal Limit (NTL) on the River Adur was at TQ 214 187, more than 6 km upstream of Stretham. From parish boundaries following old courses, and from redundant oxbows and embankments, it is evident that the river has been given its more direct present course under the Adur Navigation Act 1807 (Hudson 1987, 31). In 1700 chalk was being landed at Mock Bridge (TQ 210 182) c. 6 km upstream (Hudson 1987, 151). It is feasible then that access by river was available during the occupation of the site, much chalk having been found in the excavations.

Access from the sea, though, is much more problematical. Peat was being dug at Henfield by 1630 (Hudson 1987, 148). This implies the former existence of a freshwater lagoon in the Adur valley. From that we may infer that the shingle barrier beach, which formed after 10,000 bp from Selsey to Hythe (Kent), was sufficiently wide to prevent seawater entering the river, while remaining sufficiently porous to permit fresh water to flow through it on the ebb tide of the sea. For the peat to form, this must have been the situation over decades or centuries. Eventually, longshore drift denuded the barrier beach, and breaches would occur in it on the ebb of the spring tide (J. Eddison pers. comm.). Once the breach was open, any freshwater flowed out, and the river would become a tidal inlet, bringing seawater inland on subsequent flood tides, until longshore drift closed the mouth again.

From time to time, then, even when Steyning had become a seaport, the river was inaccessible from the sea until a new mouth formed (Elrington 1980, 139–40). Therefore, at no time during the occupation of the site could navigation by sea and river be assured. That seawater did flow inland probably as far as Stretham is demonstrated by the remains of saltworks in Upper Beeding (Hudson 1987, 29, 40).

The River Adur rises mainly on the impermeable Weald clay; therefore it is liable to suffer sudden flooding following heavy rain (E. Towner pers. comm.). Since it flows mostly over clays and sandstones it carries fluvial silt downstream. On the flood tide, seawater, bearing marine silt, flows upstream, pushing the freshwater before it. Before the river was embanked the mixed waters spread laterally up dendritic tidal creeks in the salt marshes. At high water, at the slack, the water becomes still long enough for the silt particles to drop to the creek or river bed, or to salt-tolerant plants growing there (Green 1968, 25). Subsequent tides do not flush the silt away. That the Adur is particularly susceptible to siltation is demonstrated at Bramber Bridge (Holden 1975, 104–17).

Siltation, and the consequent shifting of channels, probably made river navigation unreliable. A combination, at one time, of a spring high water, a storm surge in the English Channel, and heavy rainfall, probably overtopped embankments and rendered Stretham uninhabitable.

COMPARISON OF STRETHAM MOAT WITH OTHERS IN SUSSEX by Alan Stevens

A desktop assessment was carried out comparing other moated sites to the Stretham Moated site.

A comparison was made between the moated sites in the clay of Suffolk, and of those in the similar Low Weald of Sussex, by searching OS 1:63360 maps 137 (1946) and 182 (1960). In the 10 × 10 km square originating at TM 2060 in Suffolk, 34 moated sites were found. In the 10 × 10 km square originating at TQ 0020 in Sussex, only one could be found.

The *VCH* (Clinch, 1905, 477) lists 52 'homestead moats' and five uncertain ones. Brandon (1977, 136) claims the total exceeds 235. Using the OS 1:25,000 First Series maps, 63 moated sites, 29 rectangular or L-shaped ponds next to standing buildings, and 34 other possible sites, were counted by the writer. Only documentary or archaeological evidence may demonstrate that a set of pond or ponds constitutes a moated site.

For the present purpose the OS Explorer 1:25,000 maps suffice since they show water sources, OD levels at 5 m intervals, and propinquity to tidal water. To these must be added the BGS 1:50,000 maps, solid and drift edition, since they show surface deposits.

Particular attention was then paid to those moated sites lying on or below 5 m OD, near rivers, which were therefore liable to suffer both fluvial and marine flooding. These were then checked for their surface geology.

TQ 200 137 STRETHAM

Two neighbouring moats (Clinch 1905, 477; T Hudson, pers. comm.).

The excavated moat *c.* 4 m OD alluvium, abandoned

East (Stretham Manor) 5 m OD, river terrace deposit, inhabited.

The river is tidal at NTL up to 7 km upstream of Stretham.

TQ 544 082 SESSINGHAM BRIDGE

Above 5 m OD. Alluvium, uninhabited, very small.

TQ 558 093 MICHELHAM PRIORY, *c.* 11 M OD

Sessingham and Michelham are fed by the River Cuckmere, like the Adur running off impervious

clay, and therefore liable to suffer flooding. Michelham Priory moat, cut into head, its south and east banks above the river and its alluvium. It is fed from the Cuckmere by a characteristic monastic leat, running from c. 600 m upstream. Floods, therefore, will tend to bypass the moat. Neither of these moats were probably affected by tides.

TQ 483 114 LAUGHTON PLACE AND TOWER

Just above 5 m OD. Moat cut into Gault clay. Not permanently inhabited.

TQ 651 088 WARTLING

Just below 5 m OD. Alluvium. 'Old Court', no building standing, no land access marked on maps.

This lies on Pevensey Level, near the left bank of the Kentland Fleet, presumably tidal before the inking of the level. Nearby there are winding roads, which are therefore likely to run on seawalls or creek ridges. The site appears to lie in a 'pool' (Green 1968, 25) and therefore became liable to flooding as any underlying peat was drained, and the ground surface sank in consequence.

There are several medieval moated sites below HWM behind the right bank of the Thames in Surrey. These were not cut until river embankments had been built (D. J. Turner pers. comm.). At Stretham, in 1875, there was a redundant embankment behind the modern right bank of the River Adur, extending c. 250 m northwest of the railway bridge. There is another redundant embankment behind the right bank of the river, starting c. 100 m south-southeast of the railway bridge and extending more than a km southwards, with a meandering watercourse on its west side, along which ran a former parish boundary (Fig. 2). They are probably the remnants of a continuous embankment on the left bank of a former course of the Adur, built to protect Stretham. This was destroyed after 1807 by the construction of the present embankments long after the excavated moat at Stretham had been abandoned. Stretham appears to be the only moated site in Sussex on a tidal river.

PLACE NAME EVIDENCE

by Alan Stevens

The place name presents problems, but also points to intriguing possibilities. The earliest written reference is dated July 2, 1281, when the bishop sealed a document at *Straetham* (Way 1852, 253

note 24), presumably in his manor house there. The name, then, was in use for the locality when the house was first built. There is no evidence of a village or a parish church at Stretham, so the name cannot originally have been *Straet-ham*. That leaves the form *Straet-hamm*. Dodgson (in Brandon 1977, 80 & 84) tells us that *hamm* may mean 'a natural feature or a man-made paddock', but he prefers 'a river meadow,' or 'dry ground in a marsh' by the 'Adur and on a Roman road (*straet*)'. This name would fit the excavated moat if it were on a Roman road. But that moat lies c. 300m away from M140, still in use today as a footpath on a LGS ridge. Another meaning of *hamm* is 'a promontory of dry land into marsh or water'. This fits TQ 2015 1345, where M140 meets the Adur, precisely. The writer suggests that the name was initially applied to this spot, and was transferred or extended when the complex was first built. Once a moat was required, it had to be dug in level ground, supplied by a stream, not the tidal river. The spot chosen for the excavated moat was also in a *hamm*, this time referring to a river meadow, so the existing name was fortuitously appropriate.

When the earliest buildings of Stretham Manor (TQ2015 1370), in the eastern part of the complex, were erected is not known. It was moated (Clinch 1905, 477; T. Hudson pers. comm.). The late medieval building is probably a remnant of earlier buildings (A. Hughes, pers. comm.). It might have been the manorial centre when Henfield manor began to be referred to as Stretham. It is a more likely manor site than the adjacent excavated moat within the same complex (C. Dyer & A. Hughes pers. comm.).

Stretham may also mean 'a river meadow', 'in a river bend' near a Roman road (Dodgson, in Brandon 1977, 80 & 84). That description fits the western moat; but it also renders the site liable to flooding. From this it follows that all historical references to Stretham always referred to the whole manorial complex.

SITING

by Alan Stevens

The excavation was confined within the island of the excavated moat, with two cuttings across the moat, but otherwise the moat remains unexamined. More importantly the enclosures close to the east arm of the excavated moat,

including a second moat, dissected by the former railway, were not surveyed (Fig. 2). Taken as a whole, the complex resembles category A2e, i.e. a medieval moat or moats, with enclosures of various kinds (La Patourel 1973, 3 & 4). The only indication that the moats are medieval is that buildings A, F, and B appear to respect the moat arms, and that Stretham Manor is a late medieval addition to a probable earlier house (A. Hughes pers. comm.). Alternatively, the island's irregular quadrilateral may be due to the need to respect buildings outside the moat. No direct evidence exists of the dates of any of the various moat arms and ponds within the complex.

Moated sites were dug mainly in heavy clay (La Patourel 1973, 7), obviating the need to line the moat, near a spring or stream to provide water (Taylor, in Aberg 1978, 10). Others may be dug in drift deposits (Le Patourel 1973, 7). The excavated moat was originally dug in alluvium. The eastern moat is situated on first to second river terrace deposits. Neither alluvium nor river terrace deposits hold water well, Section M–M (Fig. 5), which shows blue clay, presumably Gaul from at least 1 km downstream, lining the bottom of the moat. Wealden clay outcrops c. 250 m downstream, but at 5 m OD forming part of the promontory, and difficult to moat. This implies that the western part of the site was deliberately chosen to be close to the tidal river, despite the added expense entailed in lining the moat. The eastern part was built c. 1 m higher, but its moat probably also needed to be clay-lined.

HISTORICAL REFERENCES

by Alan Stevens

In 1066 Stretham Manor, but called *Hamfelde*, i.e. Henfield, belonged to the bishop of Selsey. By 1086 it belonged to the successive bishops of Chichester. In 1220 the bishop kept 43 cattle in order not to demand payment from his poorer tenants. The cattle required a secure enclosure to protect them from theft, and moated sites were commonly used for this (Le Patourel *et al.*, in Aberg 1978, 48). The excavated moat was ideal as it was on a meadow, once the hay had been harvested, but equally the adjacent eastern site was suitable, with pasture nearby. In 1247, St Richard, bishop of Chichester, confirmed two deeds at Henfield, presumably while staying at Stretham. Almost all episcopal visits were made in the spring or summer. In 1374 it was implied that the bishop came there at least once a year, and that conformed to the medieval practice of a holder of multiple estates eating the rent in-kind, and holding court in each in turn.

In 1378 there is reference to a watergate, (Hudson 1987, 141) which at least puts the manorial centre on the river, not in Henfield village. If an embankment was by then in place, protecting the complex from floods, the watergate was on that bank; but any remains of such a gate were probably demolished, or buried, by the new embankments of 1807 and later.

In 1388 the demesne meadows were reckoned to be of higher value than those of the bishop's other demesnes in the diocese. That implies that they were protected from seawater by an embankment, since seawater turns meadows into saltmarshes.

Between 1378 and 1410 there is reference to a chapel, normally a requirement of a bishop's residence. This gave rise to 'chapel garden' within the close containing the complex (Hudson 1987, 140–47).

REFERENCES

- Barton, K.** 1979. *Medieval Sussex Pottery*. Chichester: Phillimore.
- Brandon, P.** 1977. *The Sussex Landscape*. London: Hodder & Stoughton.
- Clinch, G.** 1905. Ancient earthworks, in *Victoria History of the Counties of England. Sussex* (hereafter *VCH*) **1**, 453–80.
- Dodgson, J.** 1978. Place-names in Sussex: the material for a new look, in P. Brandon (ed.), *The South Saxons*. Chichester: Phillimore, 54–88.
- Elrington, C.** 1980. *VCH* (6)**1**.
- Gardiner, M.** 1990. An Anglo-Saxon and medieval settlement at Botolphs, Bramber, West Sussex, *Archaeological Journal* **147**, 216–75.
- — 1993. The excavation of a later Anglo-Saxon settlement at Market Field, Steyning, 1988–89, *SAC* **131**, 21–67.
- — 1994. 'Medieval pottery', in G. Priestley-Bell, *Archaeological excavations at America Wood, Ashington, West Sussex, SAC* **132**, 46–8.
- Gardiner, M. et al.** 1996. Excavations at Lewes Friary 1985–6 and 1988–9, *SAC* **134**, 71–123.
- Gardiner, M. & Greatorex, C.** 1997. *Archaeological*

excavations in Steyning 1992–95: further evidence for the evolution of a Late Saxon small town, *SAC* **135**, 143–71.

Green, R. 1968. *Soils of Romney Marsh*. Harpenden Agricultural Research Council. Soil Survey of Great Britain, England and Wales. Bulletin 4.

Hewett, C. A. 1982. *Church Carpentry*, Chichester: Phillimore.

Holden, E. W. 1963. Excavations at the deserted medieval village of Hangleton, part 1, *SAC* **101**, 54–187.

— — 1967. The excavation of a motte at Lodsbridge Mill, Lodsworth, *SAC* **105**, 103–25.

— — 1975. New evidence relating to Bramber Bridge, *SAC* **113**, 104–17.

Hudson, P. 1987. *VCH* **6(3)**.

Le Patourel, H. 1973. *The Moated Sites of Yorkshire*. London: The Society for Medieval Archaeology, Monograph Series No. **5**.

Le Patourel, H. & Roberts, B. 1978. The significance of moated sites, in F. A. Aberg (ed.), *Medieval Moated Sites*. London: The Council for British Archaeology. CBA Research Report No. **17**, 46–55.

Machling, T. 1995. 'Pottery', in M. Gardiner, Aspects of the history and archaeology of medieval Seaford, *SAC* **133**, 204–6.

Margary, I. D. 1965. *Roman Ways in the Weald*. London: Phoenix House.

— — 1973. *Roman Roads in Britain*. London: John Baker.

Pearce, J., Vince, A. & Jenner, M. 1985. *A Dated Type-series of London Medieval Pottery*, part 2: *London-Type Ware*. London Middlesex Archaeological Society, Special Paper **6**.

Smith, A. & Hurst, J. 1963. 'Pottery', in E. W. Holden, Excavations in the deserted medieval village of Hangleton, part 1, *SAC* **101**, 54–181.

Taylor, C. 1978. Moated sites: their definition, form and classification, in F. A. Aberg (ed.), *Medieval Moated Sites*. London: The Council for British Archaeological Research Report **17**, 5–13.

Turner, D. 1974. Medieval pottery kiln in Bushfield Shaw, Earlswood — interim report. *Surrey Archaeological Collections* **70**, 47–55.

Way, A. 1852. Notices of the Benedictine Priory of St Mary Magdalene, at Rusper, *SAC* **5**, 244–62.
