

## Information for Project Officers Re: CAD methodology

### Background:

Site CAD drawings are being edited for 3 basic functions:

1. To enable the production of tagged shapefiles for incorporation into a scheme wide GIS to be deposited with KCC as part of their SMR.
2. to enable these shapefiles to be queried and subsequently incorporated as illustrations for site specific reports,
3. To provide an archive resource to be deposited with the ADS.

A consistent approach to the production of CAD drawings is the main reason for centralising the editing of the existing CAD archive drawings. Please note that the basic aim is **not** to produce a series of drawings from which all subsequent detailed site plan illustrations can be drawn. In many cases the digital data simply does not exist to support this and for consistencies sake the methodology will be geared towards the lowest common denominator.

If any information that will contribute towards this aim exists, or may be used on a site-specific basis to aid interpretation, it will be retained, but it will be ignored in terms of the overall strategy for creating shapefiles.

Stated in its most basic form what the CAD team will do is generate a closed polygon for each feature and tag this with a unique number which allows it to be linked to the database. This will be based on two data fields: the site code and the context number.

These polygons will be generated on their own layer allowing the original data to remain unedited.

What appears in the GIS as shapefiles can be misleading but the original data will be retained on a separate layer within the Autocad drawing and this can be overlain as a background within the GIS (although it will have no data attached).

*This means that for each site, every digitised feature must have a unique context number.*

Certain problems exist in generating these polygons of which a few pitfalls are outlined below. Please note that this is not a comprehensive list, it's just an indication of the sort of problems that are encountered.

1. If discrete features such as stake-holes have been given the same context number, a separate polygon will be drawn around the limits of the stake-holes, and the context number will be given to that. This means that the individual stake-holes will not appear in the GIS. *(A short cut in the methodology which saves numerous context sheets being generated during post-ex.)*
2. Similarly, if a feature has been cut by another and completely truncated, unless the separate parts have been given separate context numbers, an arbitrary line will be used to join it into one complete feature. *(A short cut in the methodology which saves numerous context sheets being generated during post-ex.)*
3. Where features are not fully defined, there will be an assumption that this is the limit of their known extent, and for the purposes of generating a closed polygon, an arbitrary line will be drawn.
4. Where the relationship between two or more features is unclear, and in the absence of any other information, a best guess may be generated by the Cad team rather than an arbitrary straight line.
5. Problems exist with islands within polygons and the translation of this between packages (e.g. ring ditches), so these will be drawn as a single polygon with its end faces snapped together. This will give the appearance of an arbitrary line linking the internal and external extents.

All of the above are necessary for the production of shapefiles with a unique value, but their limitations in terms of producing drawings must be born in mind.

Although the shapefiles will be queried to produce phased illustrations, they should be used in conjunction with the Autocad drawings.

1

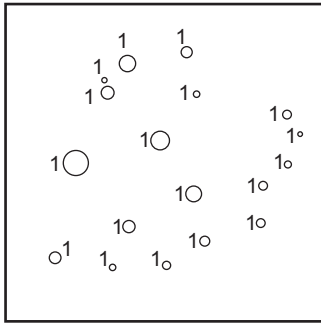

Stakeholes given the same context number

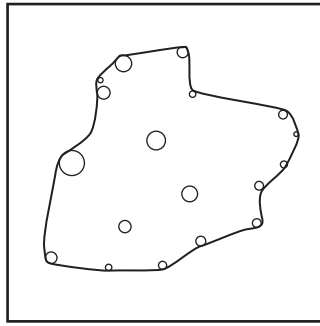

Outline of extents of stakeholes digitised

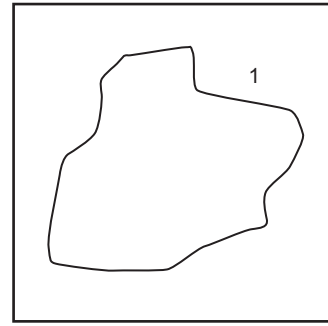

Single context number given to extents allowing unique identifier to be attached in GIS

2

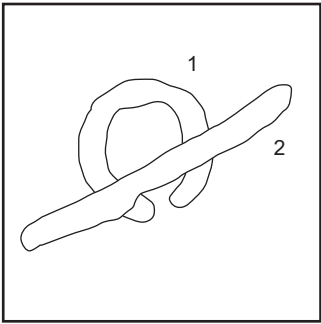

Feature truncated by another feature

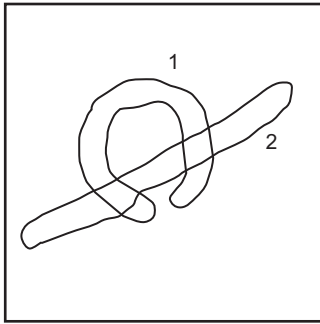

Feature 1 converted to a single shape for incorporation into GIS

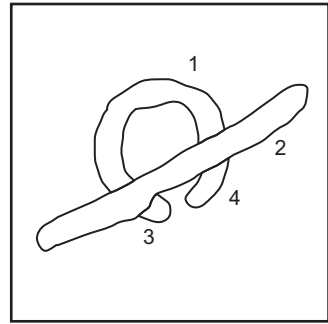

Feature 1 sub-divided into 3 separate shapes. Note this method requires the generation of further context numbers and records

3

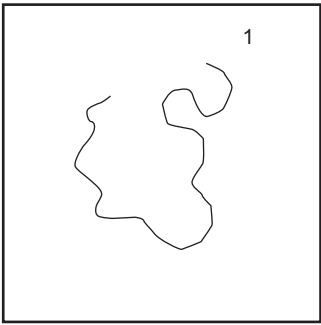

Full extents of feature not determined

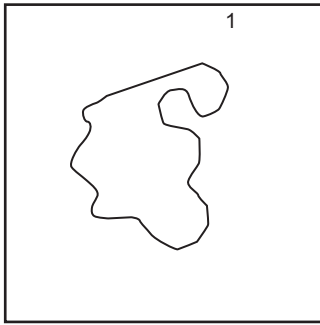

Arbitrary line drawn in order to create a closed polygon

4

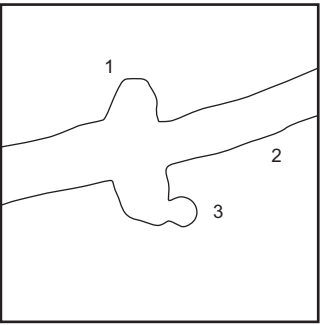

Features with no relationship identified

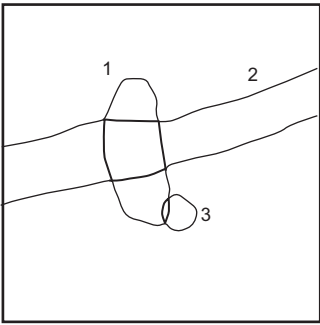

Best guess applied to creating polygons

5

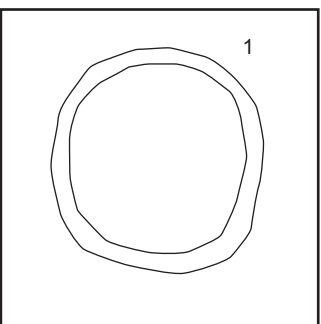

Island within feature

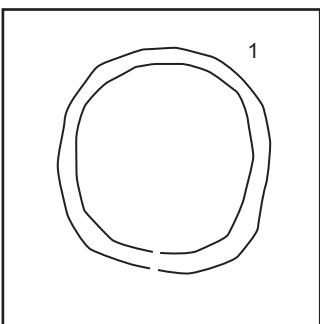

Outlines broken

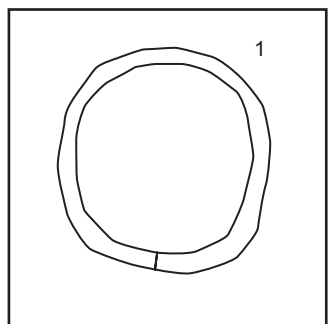

Arbitrary line drawn to close polygon

The initial drawings have been provided by four different Archaeological Units, and have been prepared from data gathered over a number of years. This means that methods not only vary from unit to unit, but also vary within each unit as general methodology has evolved, and individual sites have required.

Please be aware that the Cad team will not be familiar with the site.

They will not have access to the primary site archive and will be unable to tell which information is most up to date/relevant if provided with more than one version.

They will have no knowledge of where it is in the real world and will not be aware of how it was surveyed in.

They will also not understand coded layer names or how the drawing has been put together.

The aim is to streamline the process as much as possible for efficiency, and having all the relevant data at the beginning aids this considerably.

Where more detail is required for the analysis of cemetery sites is not part of this report and has a separate methodology although it is envisaged that the primary contexts such as grave cuts do come under the scope of this document.

Where possible the number of times that a drawing has to be revisited will be kept to a minimum, largely due to communication difficulties involved with the consultation of the appropriate project officer for each site across four different units.

***It is envisaged that each project officer will bear the responsibility of ensuring that the necessary data is supplied, and for checking drawings prior to submission to the CAD team.***

### **Methodology:**

Base level of data required. (within reason, the more information that can be provided the better).

- Details of the parent company's working methodology to produce the drawing from survey onwards.
- The limits of excavation and **any** archaeological data that exists within the drawing (e.g. features, section lines, interventions, etc.).
- Ideally all units will provide one drawing per site, ensuring that it is correctly positioned within the URL grid, or with details of how to relate the site to URL grid. Comprehensive notes about the relevance, accuracy and currency of data will be required if more than one drawing is supplied.
- Explanatory notes about how it was put together, and details of the layering structure (what layer names mean etc.) within the drawing if this is not self-evident.
- The context number for each feature to allow data tagging, preferably within the drawing, but another suitable form may be acceptable (e.g. a clearly annotated print out).

### **Method:**

A drawing/drawings is/are provided by the project officer from the parent company. It should be checked before submission since the CAD team and not the project officer will make all subsequent changes to the drawing. This is to ensure that we are all working with the same data.

There will be scope for amendments subsequently during the checking procedure, but we aim to get as complete a drawing as possible initially. For this reason it would be worth the project officer checking that features are on sensible layers and that all relevant features are incorporated into the plan before submitting a drawing for editing.

If not already in URL grid, it is translated into URL grid using information provided by the project officer.

Anything not related to the site drawing (page frames, scale bars etc) will be stripped from the drawing, including URL base maps (These may be X-referenced in at a later stage which will help to keep file sizes down, or brought in as blocks).

Closed polygons will be generated on a separate layer.

A unique identifier will be attached to each context polygon. If any features are not provided with a context number, there will be an assumption that no context records exist within the database, and therefore a polygon will not be created. These will be colour highlighted as specified above to allow project officers to check before the final drawing is submitted.

Because most of the primary drawing archive does not include interventions within features, these will not be digitised for inclusion as shapefiles.

(It is relatively common for interventions to be given separate context numbers to allow the identification of the location of finds. For the purposes of the GIS only the outline of the whole feature will be used and given an individual feature number.

Interventions will be converted into polygons and retained in the drawing should any unit wish to incorporate them into their own site specific GIS, but it will not be considered as part of the remit for the CAD team to attach any unique identification number to these.)

It is envisaged that the Cad team will complete as much as they can for each site drawing and then submit it for checking by the relevant project officer.

Any areas requiring further clarity will be colour coded with comprehensive notes indicating the nature of the problem.

The drawing will then receive any amendments and should be complete.

After this stage the drawing will be converted to Ordnance Survey grid, and anything not included in the approved drawing will not be incorporated in the GIS.

The closed polygons will be converted into shapefiles and checked within the GIS against the data.

Should it not have any data attached to the link, 3 possibilities exist:

First the number has been incorrectly entered (to be checked by initially by the CAD team in case of data entry error and then by the project officer for site archive error)

Secondly no context record exists in the database (to be checked by project officer and a context record entered into the database)

Thirdly no context record has ever existed for the feature (to be checked with project officer and then the polygon will be deleted)

There is no easy way to check whether every cut is represented on the site plan as some cut features may only appear in section.

It is envisaged that only the initially supplied and the final completed and checked drawing will be submitted for uploading onto the project extra net. The initial drawing as an outline of the site (preferably with context numbers on) to provide a broad reference and the final version providing a reference for data converted to shapefiles.