

Three excavations in medieval Dumbarton: 94–102 and 101–3 High Street and 75 College Street

Russel Coleman*

with contributions by David Perry, the late Thomas Robertson, Derek Hall, Julie Franklin, Adrian Cox, Catherine Smith, Tim Holden & Effie Photos-Jones

ABSTRACT

This report describes the results of three archaeological excavations which took place within the medieval burgh of Dumbarton, two by Eric Talbot between 1971 and 1972 on the High Street and at College Street and the third, on the High Street, by SUAT in 1997. Evidence of medieval activity, including metal working, was found on burgage plots in the High Street. A large pottery assemblage provided an important opportunity to investigate medieval trends in a west coast burgh, an area hitherto under-represented in ceramic studies. Glass waste at College Street may have originated from the site of the late 18th/19th-century Dumbarton Glassworks.

INTRODUCTION

The publication of the results of excavations in 1997 at 94–102 High Street, Dumbarton provided an opportunity to prepare reports on several earlier archaeological investigations which had taken place in the town during the 1970s: at 101–3 High Street and 75 College Street. Prior to the 1997 excavation, there had been no detailed published work on the archaeology of medieval Dumbarton although the implications of development in the burgh were first highlighted in 1972 (Simpson). In 1996 Dumbarton was included in the most recent Historic Scotland funded Scottish Burgh Survey Series (1994–7), from which the following summary is derived (Dennison & Coleman 1999).

HISTORICAL AND ARCHAEOLOGICAL BACKGROUND

The royal burgh of Dumbarton is situated on the north shore of the Firth of Clyde, approximately

1km inland, on the east bank of the River Leven (illus 1). The medieval town received its burgh charter from Alexander II (1214–49) in 1222. Dominating the town, at the confluence of the Leven and the Clyde, stands Dumbarton Rock, the narrowing of the Clyde here partly explaining the site's strategic importance. In the early medieval period, this was the principal stronghold and political centre of the Britons of Strathclyde, known to them as *Alcluith* (Clyde Rock), and to the Gaels of Dalriada and the Irish annalists as *Dun Breatann* (Fort of the Britons). The Venerable Bede, writing in AD 731 (Latham 1968), refers to the place as *civitas Brettonum munitissima* – a very strongly defended political centre of the Britons – and it is possible that the site which became the burgh of Dumbarton was situated on or close to a harbour or trading centre associated with the Rock.

Occupation of the Rock may have begun as early as the fifth century AD (Alcock & Alcock 1990). It may not have been completely abandoned between AD 870 and the building

* Headland Archaeology, 13 Jane Street, Edinburgh EH6 5HE

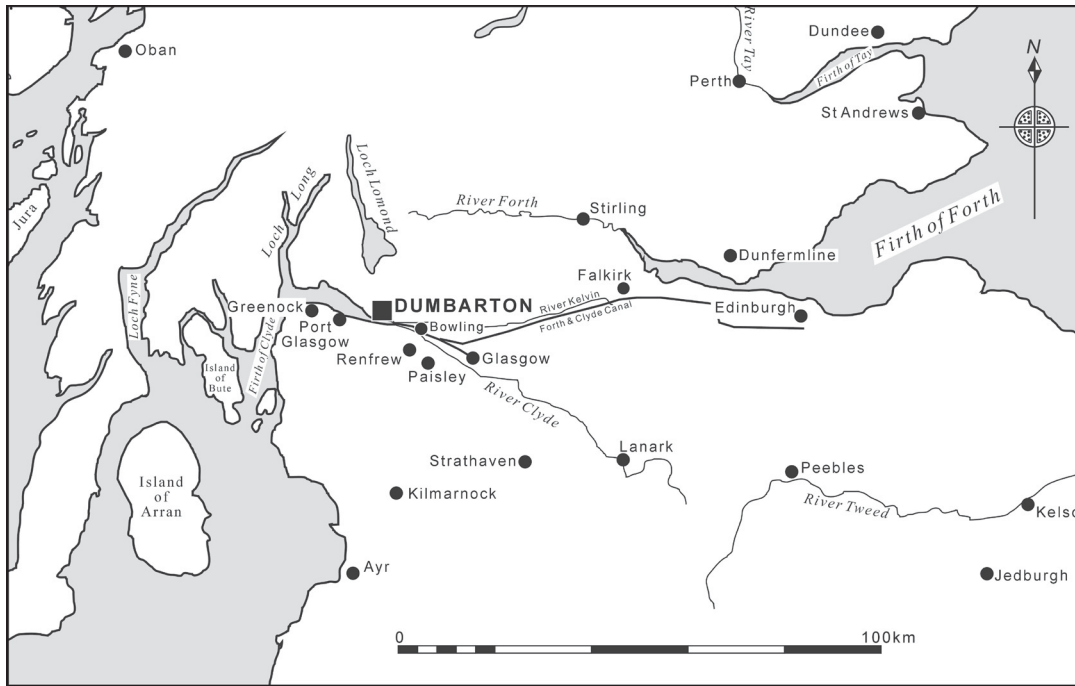

ILLUS 1 Dumbarton regional setting

of the first medieval castle; fragments of two recumbent cross-slabs of 10th-century date, possibly associated with St Patrick's Chapel, were discovered on its lower slopes. From 1238, the Rock was developed as a royal castle, subject to numerous sieges throughout the 14th, 15th and 16th centuries, subsequently becoming an artillery fortification and barracks guarding the approaches to Glasgow.

The land chosen for the burgh itself is thought to have been a 'greenfield' site (illus 2). New settlers were given five years to build and occupy a house on their plot of land (burgage plot), a period of time known as the *kirseth* during which no dues were liable. The geographical and political location of Dumbarton, at the western edge of the kingdom and on the boundary between the highlands and lowlands, may go some way towards explaining why this new settlement proved less attractive than other 12th- and 13th-century Scottish burghs. Nevertheless,

the castle required considerable labour and services, which the burgh duly provided.

As well as the rights to hold weekly markets and annual fairs, Dumbarton also held a monopoly over staple commodities produced within an extensive rural hinterland stretching from Glasgow in the east to Loch Fyne in the west, goods which could only be bought and sold at the market place in Dumbarton, as well as controlling the export of wool, hides and animal skins. Similarly, the burgh held a monopoly over river-borne trade between Loch Long and the Water of Kelvin, which led to numerous disputes with Glasgow, Renfrew and Ayr. The problem of sandbanks meant that ships could often get no further up the Clyde than Dumbarton securing its role as an important sea port. As a reflection of these rights and privileges, Dumbarton was permitted a merchant guild, one of the earliest in Scotland, in existence by 1222.

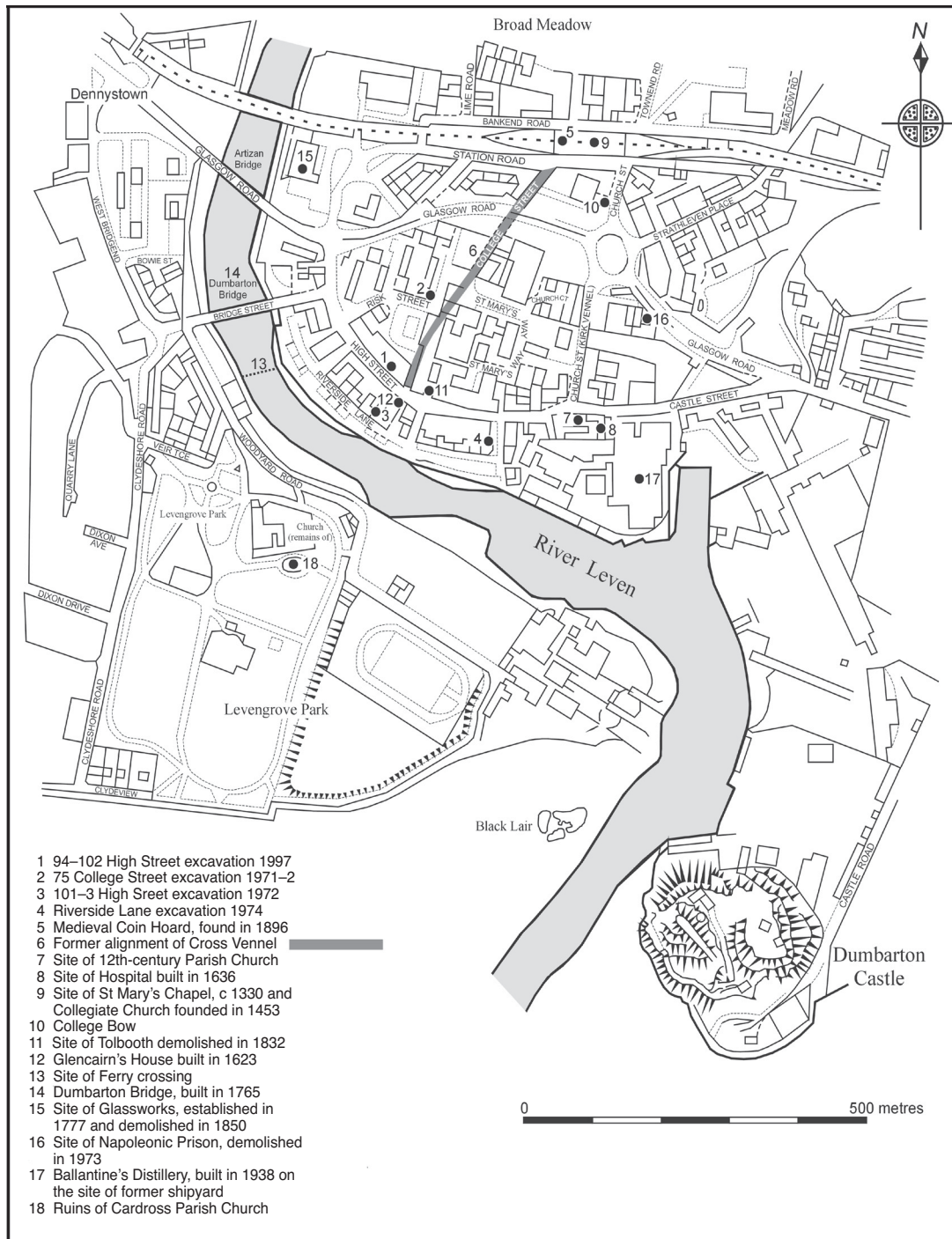

ILLUS 2 Topography of medieval Dumbarton showing location of excavated sites

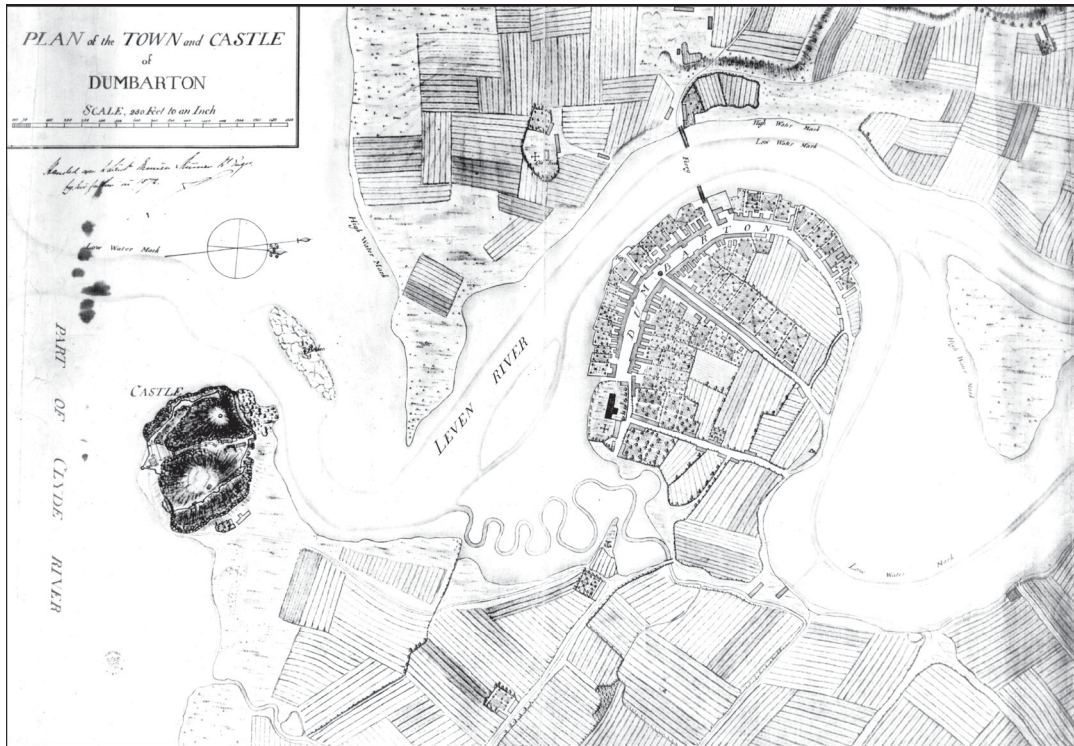

ILLUS 3 Plan of the Town and Castle of Dumbarton (Board of Ordnance, undated but pre-1765) (Crown Copyright: RCAHMS; reproduced by permission of The British Library (Add. Ms 33231 L))

THE TOPOGRAPHY OF THE MEDIEVAL BURGH

Little remains of the medieval burgh other than the town plan itself (illus 2 & 3). The main thoroughfare was High Street, with two secondary streets, Cross Vennel (now College Street) and Kirk Vennel (now Church Street). The curving alignment of High Street, reflecting the course of the flood-prone River Leven, must have influenced the layout of the original medieval properties or burgage plots. To compensate, plots were (and still are) wider on the High Street frontage, narrowing to the rear, creating a radial pattern. This is illustrated to best effect on early maps of Dumbarton such as Wood's (1818) and Ordnance Survey (OS) maps of 1866 and 1898.

The parish kirk, standing at the east end of High Street, is known from at least the 14th

century; the present structure is of 19th-century date. A chapel stood at the north end of the town by at least 1329, later becoming the collegiate church of St Mary in 1423, possibly with a hospital attached. The College Bow, part of a porch into this establishment, is all that remains, although not on its original site. The market place was located at, or near, the junction of High Street and Cross Vennel, with the market cross, tolbooth and tron close by. The oldest standing building is Glencairn's House (built 1622), opposite to the junction of High Street and Cross Vennel.

By the later 18th century, the area to the north of the bridge, built in 1765 close to the old ford, and west of High Street, was developed for industry. Glass and chemical works were established there in 1777. In 1858 Broad Meadow was drained and embanked after the construction of the Bowling to



ILLUS 4 94–102 High Street excavation 1997: location



ILLUS 5 94–102 High Street, Plot 2. General view showing former burgage plots cut in half by modern development (SUAT Ltd)

Balloch railway line. By the time of the first detailed plan of the town (Board of Ordnance pre-1765: *illus 3*) the street frontage of Cross Vennel was fully developed, as were parts of Kirk Vennel's.

THE EXCAVATED SITES

Two sites, 75 College Street and 101–3 High Street, were excavated in 1971 and 1972 by Eric Talbot, of the Department of Archaeology, University of Glasgow, funded in the second season by the Department of the Environment (*illus 2*). Students from the university archaeology department, volunteers from the field-work group of Glasgow Archaeological Society and Mr Talbot's extra-mural classes manned the excavations. Unfortunately, despite an exhaustive search, SUAT was unable to trace the original site records of either excavation, which had gone astray in the course of the intervening 25 years. However, a skeleton

stratigraphic sequence and phasing for these sites was reconstructed from post-excitation plans prepared after the first season of the excavation and a pottery report written as a degree dissertation by Genet Titmus. The post-excitation plans, in colour slide form, were kindly loaned to SUAT by Eric Talbot along with his own personal records. Information was also derived from accounts in *Discovery and Excavation in Scotland* (Talbot 1971; 1973) and *Bulletins of the Glasgow Archaeological Society* (Talbot 1972a; 1972b; 1972c). In the absence of detailed context or stratigraphic information, only a summary of the excavated features can be given. The finds, however, had only recently been deposited in the Hunterian Museum, prior to which they had been held for many years by Dumbarton Library Services, at some time having been damaged during a fire.

During the writing up of Eric Talbot's excavations, evidence of a fourth site, excavated by the late Thomas Robertson at Riverside Lane in 1974, was discovered (Robertson 1974, 80).¹ The site of the most recent excavation, the first for over 20 years, lay on the north side of the High Street (nos 94–102) almost directly opposite Eric Talbot's excavation at 101–3 High Street.

EXCAVATIONS AT 94–102 HIGH STREET, 1997

The excavation at 94–102 High Street (Site Code DT02) was carried out by SUAT Ltd over a period of four weeks during August and September 1997, prompted by the refurbishment and partial rebuilding of the former Cantors furniture store, now the Halifax bank. The site lies to the west of the junction of High Street and College Street, the latter now blocked off but still visible, and occupies three former medieval burgage plots on the frontage but only two to the rear (*illus 4*). In the medieval period, these plots would probably have stretched some 70m back (north) from High Street, but today they extend less than half that distance, the area to the north having largely been cleared for car parking and access to the 1960s shopping precinct (*illus 5*).

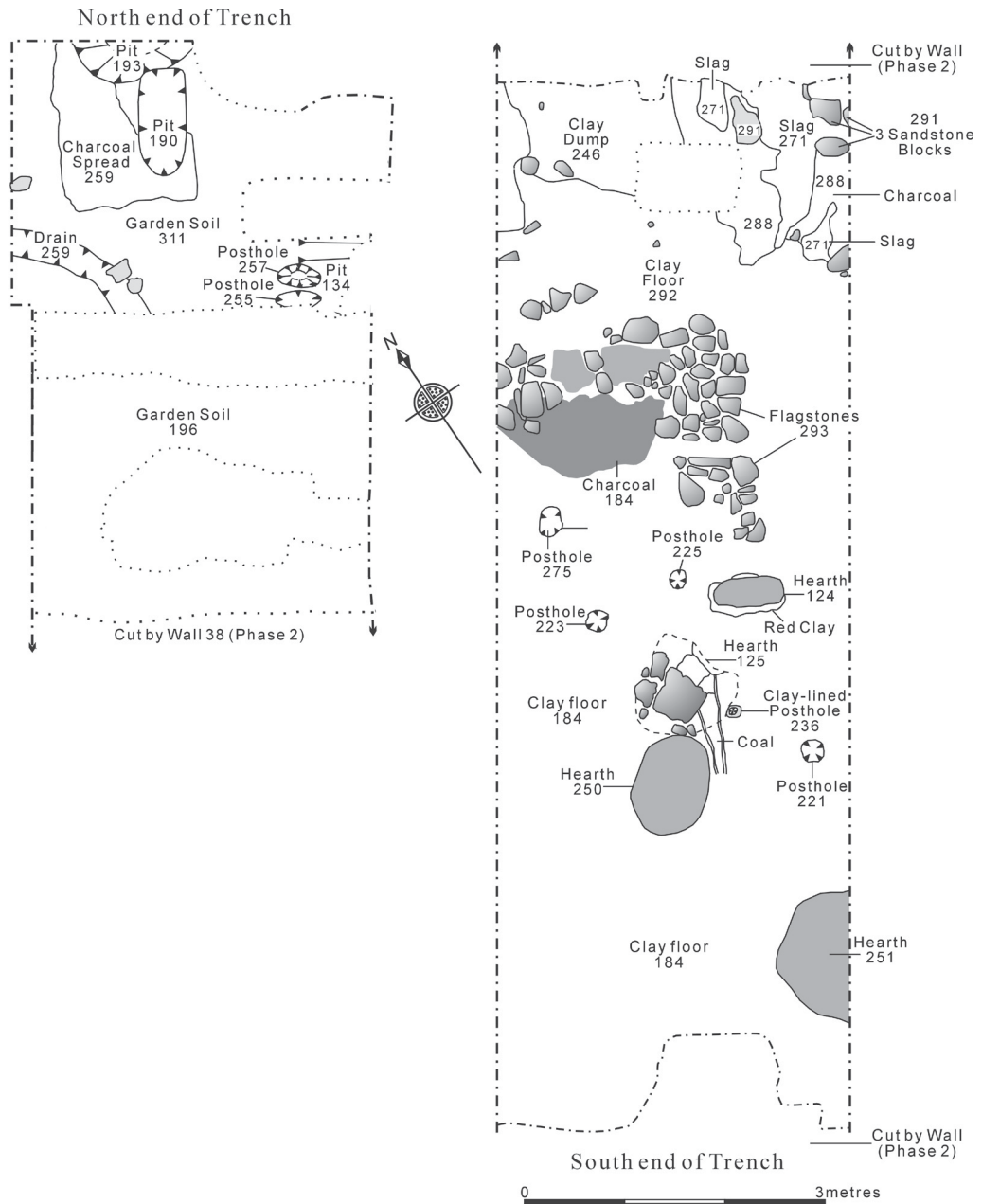

ILLUS 6 94–102 High Street. Plot 1, Phase 1

The initial site evaluation (Cachart & Coleman 1997) identified medieval and post-medieval deposits in five test pits (A–E) including garden soils, pits, hearths and scorched surfaces. The pottery assemblage provided good dating evidence for the

development of the site through the medieval period into the early modern period.

Although archaeological levels were found to survive extensively across the site, the excavation strategy was tied exclusively to the formation

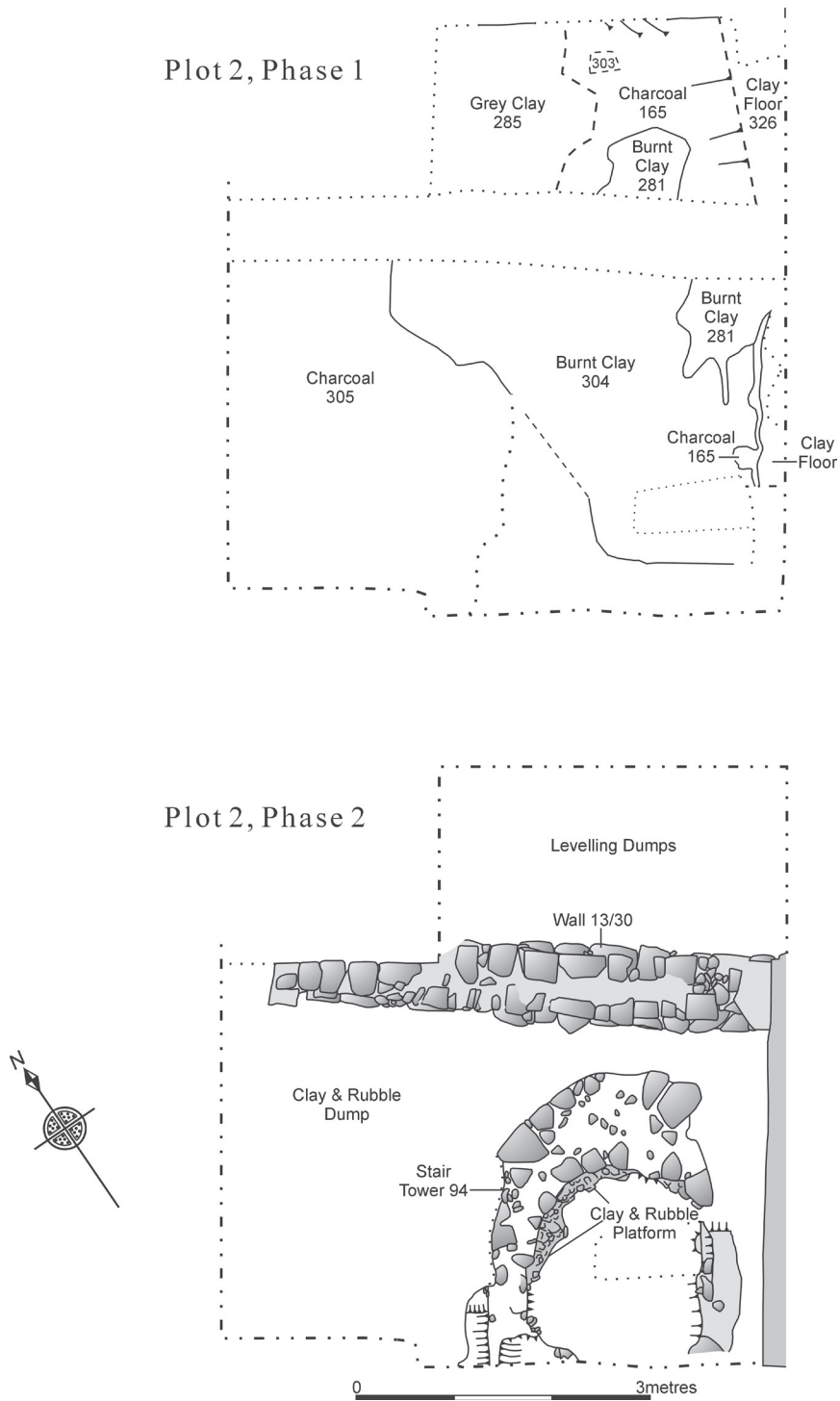

ILLUS 7 94–102 High Street. Plot 2, Phases 1 & 2

level of the new building (3.53m OD). Up to 0.5m of archaeological deposits remain preserved in situ beneath the new building. Two backland areas were identified as being at risk, necessitating the excavation of up to 0.5m of deposits. On the frontage, however, there was little requirement for archaeological work except to record those deposits exposed after the breaking out of the existing concrete floor surface. Two engineers' test-pits dug in the westernmost part of the frontage glimpsed a sequence of floors, and a possible midden-deposit surviving intact to a depth of at least 0.6m below the new formation level.

Only the eastern plot (Plot 1) and central plot (Plot 2) were under threat. No medieval plot boundaries were identified in the excavation but the modern building lines suggest Plot 1 measured c 6.5m at the rear of the site and c 7.5m on the frontage. Plot 2 measured c 5.5m at the rear of the site and c 6.5m on the frontage.

Since excavation terminated at different levels and much of the archaeology was preserved in situ, there were too few stratigraphic links to enable integrated site-wide phasing. Nevertheless, three broad phases were identified, from the medieval period (Phase 1), through the late medieval/early modern period (Phase 2), to the Victorian and modern period (Phase 3). For ease of description, the site has been divided into its three phases, then by plot.

PHASE 1: 13TH–15TH CENTURY

Plot 1 Building

In the backlands of Plot 1 (illus 6), a rectangular building, set at a right angle to the street frontage, had been constructed over what were originally gardens. Numerous hearths, scorched floor surfaces and extensive spreads of charcoal and ash indicate that the building's function was probably industrial, perhaps with living accommodation above.

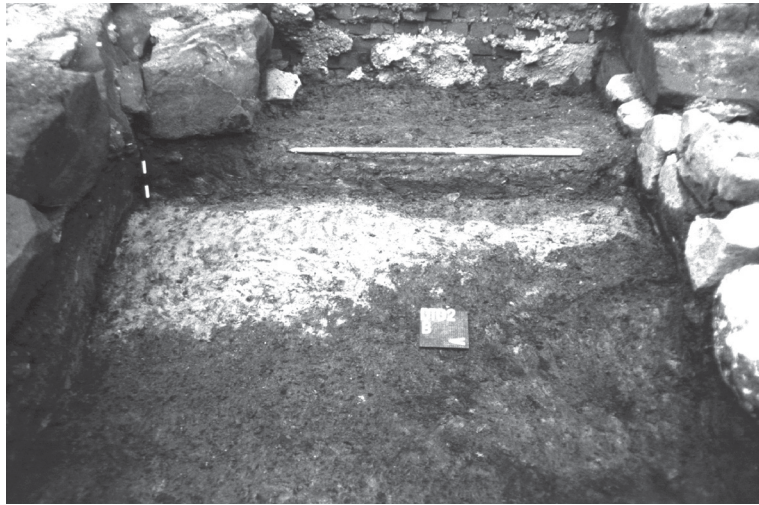

ILLUS 8 94–102 High Street. Plot 2. Clay floor of possible timber building exposed at new formation level (*SUAT Ltd*)

Few finds were recovered from within the building. However, a substantially complete jug, with the neck missing or deliberately cut off, may have stood next to one of the numerous working hearths either as a fire precaution or as a portable quenching trough. A levelling deposit above floor 184 contained 75 sherds of White Gritty ware, one with a possible owner's or maker's mark.

External yard and garden area

Outside the building at the northern end of Plot 1, a thick deposit (0.5m) comprising cultivation soils, hearths, shallow pits and drains was uncovered, indicating this area was in use periodically as a garden and yard. The lower garden surface was left in situ. Cut 259 was probably a wood-lined drain, although there was no conclusive evidence of cess material.

Plot 2 Building

In the backlands (illus 7), a building, probably timber-walled, was constructed over an earlier garden, which in turn sealed earlier features, including a cesspit. Extensive spreads of charcoal and burnt clay, possibly daub or clay hearth/furnace fragments (illus 8), suggest it functioned either as a workshop or a domestic building that had burnt down, accidentally or deliberately.

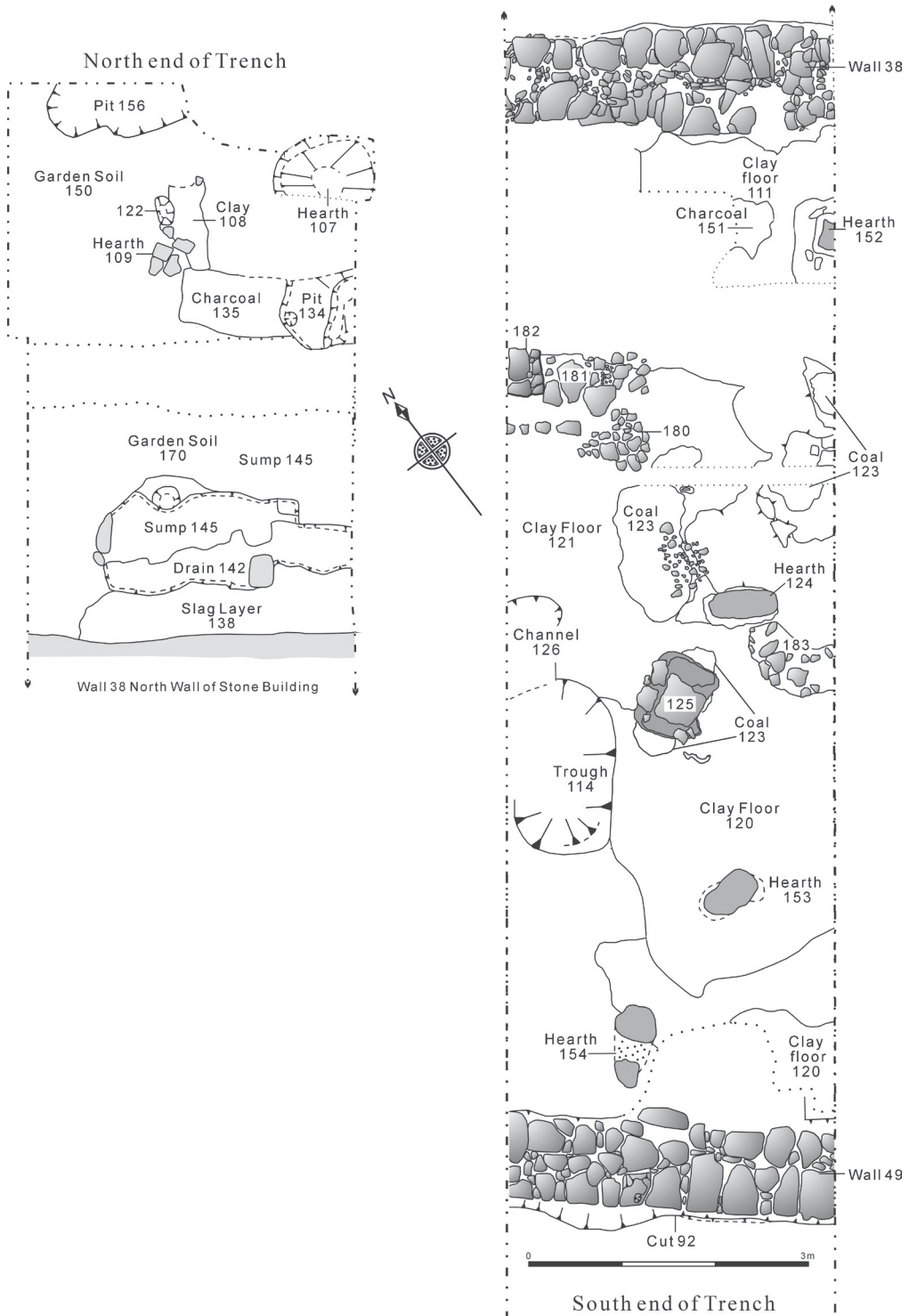

ILLUS 9 94-102 High Street. Plot 1, Phase 2

Cesspit

Natural subsoil, comprising coarse sand and gravel, was encountered at c 03m OD, to the north of the area shown on illus 7. Cut into the subsoil and probably the earliest feature identified was a shallow pit, 0.15m deep at the south end and 0.35m at the north, truncated by a Victorian wall. Analysis of the fill indicated it was a cesspit.

PHASE 2: 15TH-17TH CENTURY

Plot 1

In the backlands (illus 9), the walls of the earlier building were replaced with a series of substantial stone footings. The foundation trench cut through the earlier (Phase 1) floor surfaces. The south wall (49) was left in situ; the north wall (38), however, had to be removed. The west wall lay beyond the limit of the excavation and the east wall is probably marked by the line of the main brick wall of the standing building. Estimated internal dimensions of the building are 10.6m (N/S) and c 4.5m (E/W).

New hearths were established on the clay floor, through which a shallow tank, possibly a quenching trough (114) associated with smithing, was sunk. The original function of the building, therefore, appears to have continued, and at least one of the earlier (Phase 1) hearths remained in use. At the end of this phase, the cut for the trough was backfilled with a compact silty clay (115) containing abundant coal and slag fragments. Two sherds of Saintonge Green/Brown ware indicated a 16th-century date for the backfilling, and perhaps the abandonment of the hearths.

To the north of the building, numerous small pits and a drain were sealed beneath a thick deposit of loamy soil (150, 170), indicating continued use as a garden/yard. A large drain and sump served the stone building immediately to the south. Cut through the garden soil (150) at the northern end of the trench were some hearths and pits. A small fragment of a clay hearth base, crucible or furnace was found in the hearth fill (170). When the hearth went out of use, it was capped with a large fragment of mill stone (Cat 14, illus 17).

Plot 2

In the backlands (illus 7, lower), a clay-bonded stone wall and a circular stair-tower (94) (illus 7, 10) were built over the earlier medieval timber structure. In



ILLUS 10 94–102 High Street. Plot 2. Circular stair tower and wall of adjacent building (SUAT Ltd)

turn, these two stone structures were sealed beneath thick, artefact-rich levelling dumps deposited at the end of this phase.

The pottery assemblage recovered from Phase 2 is very similar to Phase 1 and is again almost exclusively comprised of White Gritty and Reduced Gritty wares, with a few more exotic imports such as Donyatt Ware from Somerset. Diagnostic finds were a pegged roof slate (Cat 16), a stone weight or witch's stone (Cat 15), and a knife blade (Cat 6).

PHASE 3: 18TH-20TH CENTURY

Much of the excavated evidence of the site's more recent history is recorded on the First Edition OS plan of 1866, which shows two properties on the frontage separated by a pend, and buildings to the rear (illus 11). In the backlands, much of the area once occupied by the late medieval stone building and yard in Plot 1 was sealed beneath a thick dump of clay and rubble, in advance of the construction of these new buildings

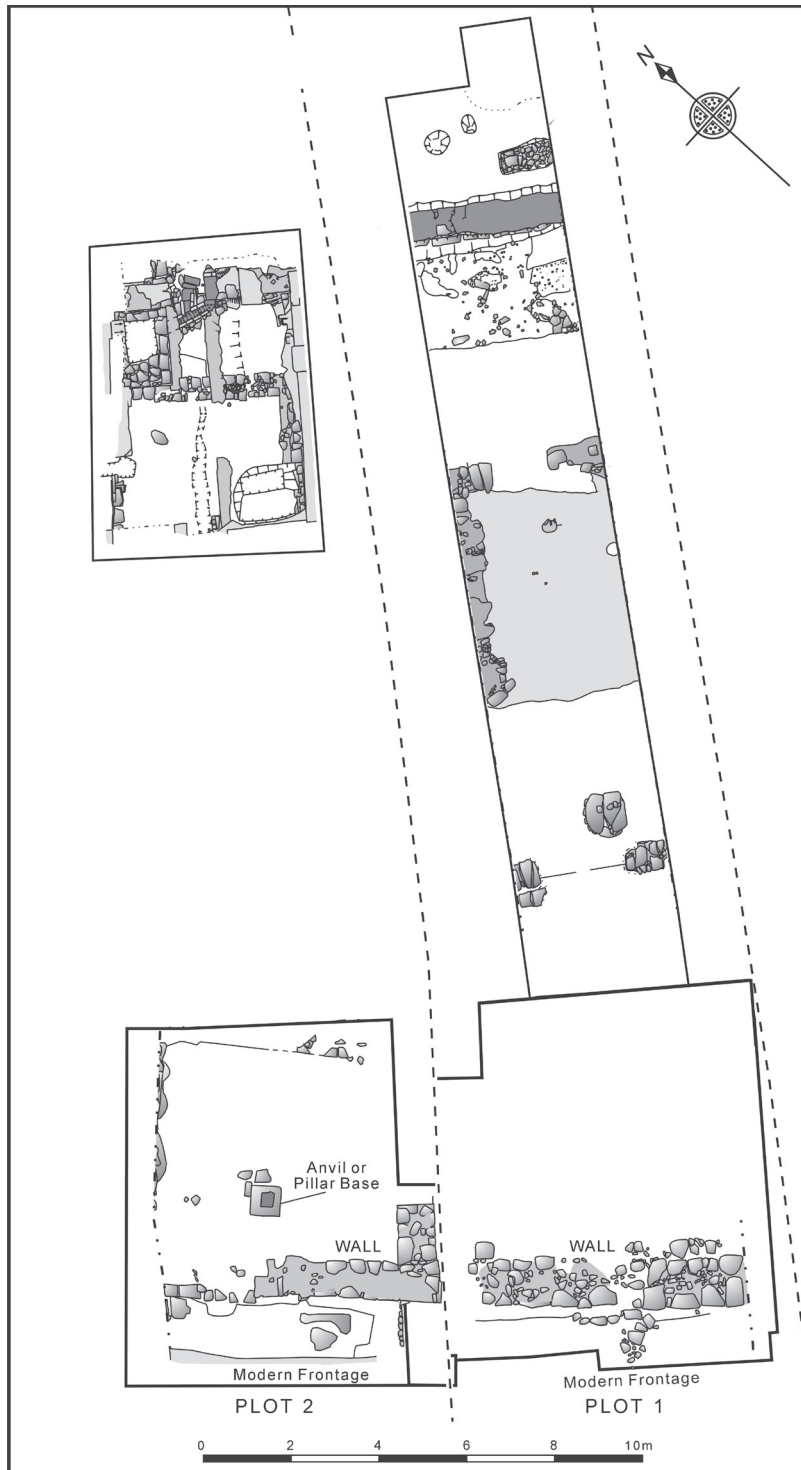

ILLUS 11 94-102 High Street. Plots 1 & 2, Phase 3

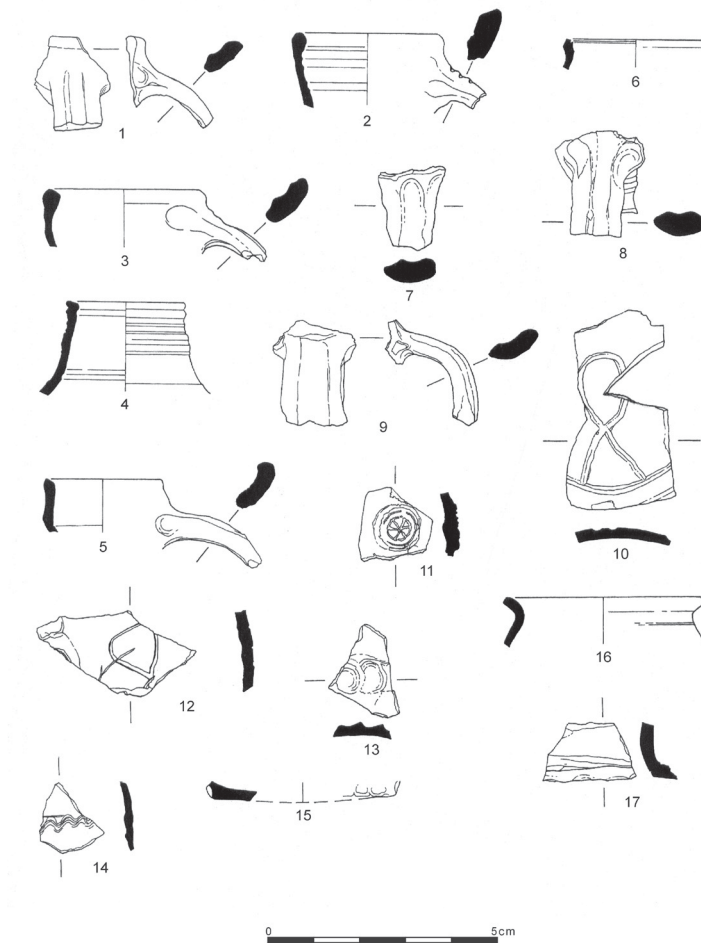

ILLUS 12 94–102 High Street: pottery

in the 18th or 19th century. On Plot 1 at least, these later buildings reused many of the earlier, medieval clay-bonded walls as foundations.

In the backlands of Plot 2, the building, which occupied much of the area under excavation, demolished in 1997, is also recorded on the 1866 OS plan. It had, however, been subject to numerous alterations and improvements, each masking earlier periods of use, and contained some structural features of interest.

The pottery assemblage, much of it residual, is dominated by china and earthen wares, but earlier wares indicate that some features in this phase may be 18th century in date. Glass waste and bottles (Cat

9–13) were plentiful, no doubt reflecting the local importance of the Dumbarton Glassworks Company, established 1777.

POTTERY FROM 94–102 HIGH STREET (ILLUS 12–15)

Derek W Hall

The site assessment and main excavation produced a total of 1730 sherds of pottery ranging in date from the 13th and 14th centuries through to the 19th century. This material has been identified by eye and assigned a recognized fabric name.

TABLE 1
Pottery from 94–102 High Street, Plot 1 (Areas A and D)

<i>Phase</i>	<i>Rgrt</i>	<i>Oxg</i>	<i>WG</i>	<i>ReG</i>	<i>Red</i>	<i>SGG</i>	<i>AngD</i>	<i>Slp</i>	<i>Ston</i>	<i>Ital</i>	<i>Ibe</i>	<i>TGE</i>	<i>Rh St</i>	<i>Earth</i>	<i>Unid Fre</i>	<i>Dony</i>	<i>Unid</i>
1	139	1	171	3	0	0	0	0	0	0	3	0	0	0	0	0	1
2	108	3	76	55	11	0	0	0	0	0	2	4	0	3	0	0	3
3	12	2	4	19	0	2	0	2	7	0	0	4	2	11	2	0	3
Total	259	6	251	77	11	2	0	2	7	0	5	8	2	14	2	0	7

653 sherds in total

Gritty Wares The fabric parameters match those previously defined for White Gritty wares (Haggarty 1984). Three potential east coast production centres have been identified, in Lothian, Borders and Fife regions, although a programme of chemical sourcing has suggested that kilns producing this fabric were more widespread than previously thought (Haggarty 1984; Hall 1997; Will et al, forthcoming). It was found on excavations at King Edward Street in Perth in association with 12th-century imported fabrics and appears to predate the East Coast Redware industry (Hall 1996b, 125). It is most commonly highly fired to a white or grey colour and contains quartz inclusions. The vessels present in this assemblage are mostly large jugs (illus 13.26). One example has what may be an owners' mark scratched into it (illus 13.25). The Dumbarton High Street group also contains sherds of oxidized and reduced variants of the standard White Gritty fabric, a trait identified in

medieval pottery from excavations in Ayr (Franklin & Hall, forthcoming) and the Scottish Borders (Hall & Crowdie 2002). The recovery of this fabric in increasingly large quantities from the west coast burghs indicates that it is unwise to treat it purely as an east coast product. The Dumbarton assemblage contains a large group of sherds in Reduced Gritty ware, apparently from large green-glazed jugs, occasionally decorated with stamped designs (illus 12.11) or even incised symbols (illus 12.10). The heaviness and thickness of the fabric indicates a date in the late 16th or early 17th centuries. It may be argued that these Reduced gritty wares represent the west coast equivalent of the late medieval Reduced greywares (see below).

East Coast Redware This fabric type is now recognized as a Scottish east coast tradition,

TABLE 2
Pottery from 94–102 High Street, Plot 2 (Area B)

<i>Phase</i>	<i>Rgrt</i>	<i>Oxg</i>	<i>WG</i>	<i>ReG</i>	<i>Red</i>	<i>SGG</i>	<i>AngD</i>	<i>Slp</i>	<i>Ston</i>	<i>Ital</i>	<i>TGE</i>	<i>Rh St</i>	<i>Earth</i>	<i>Unid Fre</i>	<i>Dony</i>	<i>Unid</i>
1	12	2	6	0	0	0	0	0	0	0	0	0	0	0	0	0
2	144	7	43	144	61	3	1	0	0	0	4	2	3	5	2	6
3	4	0	1	23	23	1	0	0	0	2	120	0	55	12	1	0
Total	160	9	50	167	84	4	1	0	0	2	124	2	58	17	3	6

687 sherds in total

Rgrt Reduced Gritty Ware; *Oxg* Oxidized Gritty Ware; *WG* White Gritty Ware; *ReG* Reduced Greyware; *Red* Redware; *SGG* Saintonge Green Glaze; *AngD* Anglo Dutch Tinglaze; *Slp* Slipware; *Ston* Stoneware; *Ital* Italian Tin Glazed Polychrome; *Ibe* Iberian Coarseware; *TGE* Tin Glazed Earthenware; *RhSt* Rhenish Stoneware; *Earth* Earthenware; *UnidFre* Unidentified French; *Dony* Donyatt Ware; *Unid* Unidentified

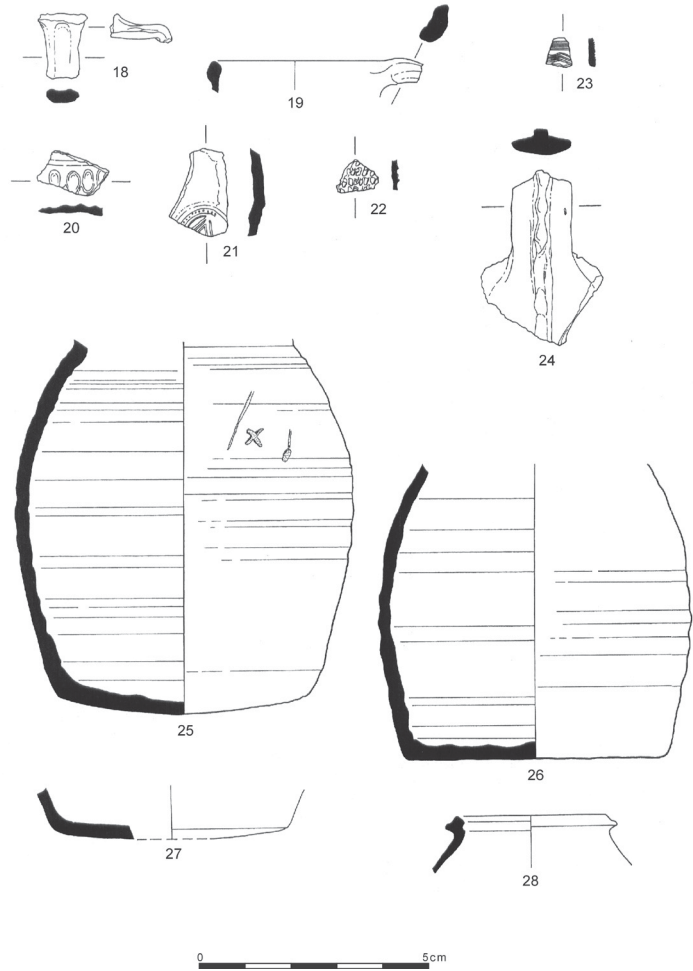

ILLUS 13 94–102 High Street: pottery

recovered from virtually every east coast burgh where archaeological investigation has taken place (Hall 1996a, 135). The Dumbarton sherds belong to the later end of the industry and may date to the 16th or 17th centuries; the sugar mould from the site assessment is an unusual find (illus 14.33).

Reduced Greyware First identified from excavations at Stirling Castle in 1980 (Haggarty 1980), this fabric may be seen as a late medieval equivalent of the East Coast Redwares, indicating a change in kiln technology and a move towards mass production in the late 15th and early 16th centuries (Hall 1996a).

Donyatt Ware Three sherds from a slip-decorated red earthenware bowl (illus 15.49) are a product of the Donyatt kilns in Somerset (R Coleman-Smith, pers comm), in production for at least 800 years. These distinctively decorated bowls are dated to between 1600 and 1650 (Coleman-Smith & Pearson 1988, 92).

Saintonge Green Glazed Vessels There are six sherds from green glazed jugs and bowls in Plot 2. These are all from vessels dating to the late 16th or 17th centuries (G Haggarty, pers comm).

Unprovenanced French Fabric Three vessel sherds of 16th-century date are decorated with finely drawn

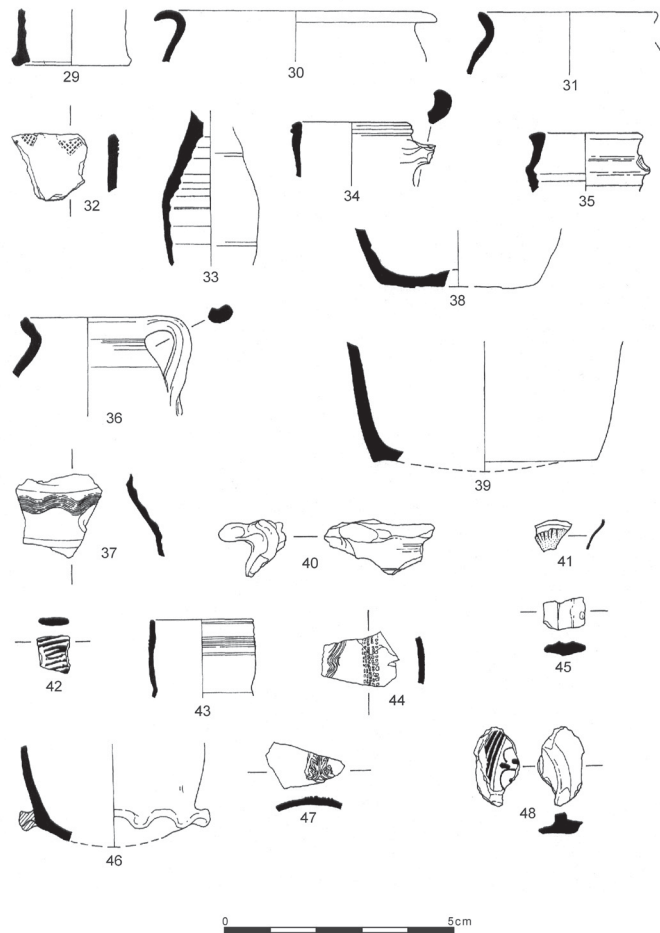

ILLUS 14 94–102 High Street: pottery

brown lines and 'feathery' leaves (illus 14.44). Probably originating in France, their precise place of manufacture is not known.

Italian Tin-glazed Polychrome Two sherds are likely to originate from Northern Italy (pers comm Duncan Brown), produced in Tuscany in the 15th and 16th centuries (Hurst et al 1986, 12–26). One fragment from a parrot beak spout (illus 14.41) and another of delicate strap handle (illus 14.42) are residual in Context 75 in Plot 2, hinting at the presence of earlier deposits in this part of Dumbarton.

Iberian Coarsewares Five sherds from Merida-type olive jars from Contexts 150, 167 and 190 in Plot 1 date to the 16th or 17th centuries (A Gutierrez, pers comm).

Rhenish Stoneware There are four sherds of Rhenish Stoneware from Plots 1 and 2, the most characteristic a fragment of facemask from a 16th-century *Bartmann* jug (illus 14.47) (Hurst et al 1986, 214).

Anglo Dutch Tin Glazed Earthenware A single base sherd (illus 14.48) in this fabric from Context 97 in Plot 2 dates to the 16th or 17th centuries (G Haggarty, pers comm).

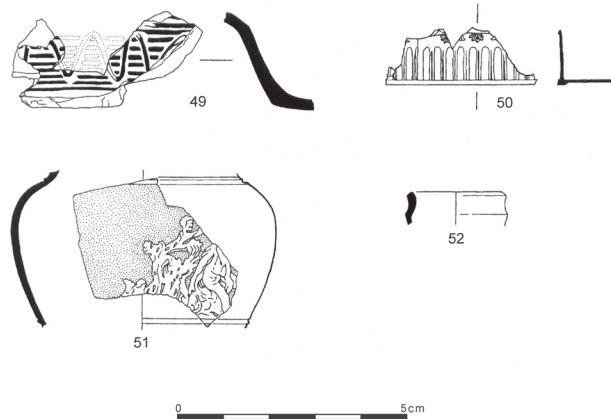

ILLUS 15 94–102 High Street: pottery

CATALOGUE OF ILLUSTRATED SHERDS FROM 94–102 HIGH STREET

Reduced Gritty Ware

- 1 Rim and strap handle from brown glazed jug. Plot 1; Area A; Context 168; Phase 1.
- 2 Rim and upper part of notched strap handle from jug glazed green. Plot 1; Area A; Context 192; Phase 1.
- 3 Rim and handle junction glazed green. Plot 1; Area A; Context 138; Phase 2.
- 4 Rimsherd from green glazed jug with heavily-rilled neck. Plot 1; Area A; Context 150; Phase 2.
- 5 Rim and strap handle from green glazed jug. Plot 2; Area B; Context 161; Phase 2.
- 6 Rimsherd from jug externally glazed green. Plot 1; Area A; Context 170; Phase 2.
- 7 Strap handle from jug glazed green. Plot 2; Area B; Context 164; Phase 1.
- 8 Strap handle from green glazed jug. Plot 1; Area A; Context 150; Phase 2.
- 9 Strap handle from green glazed jug. Plot 2; Area B; Context 163; Phase 2.
- 10 Bodysherds from large green glazed jug decorated with incised symbol. Plot 1; Area A; Context 168; Phase 1.

11 Bodysherd from jug with stamped decoration on raised circular clay pad. Plot 1; Area A; Context 168; Phase 1.

12 Bodysherd from jug decorated with incised lines. Plot 1; Area A; Context 184; Phase 1.

13 Bodysherd from green glazed jug decorated with applied thumb pads. Plot 2; Area B; Context 4; Phase 2.

14 Bodysherd from green glazed jug decorated with incised wavy lines. Plot 2; Area B; Context 59; Phase 2.

15 Thumb pad basesherd externally glazed green. Plot 2; Test Pit D; Context 4; Phase 1.

16 Rimsherd from externally smoke blackened cooking pot with traces of internal green glaze. Plot 2; Area B; Context 127; Phase 2.

17 Basesherd from dripping pan (?) with traces of internal brown glaze and external incised line. Plot 2; Area B; Context 100; Phase 2.

18 Folded skillet handle with traces of brown glaze and external smoke blackening. Plot 2; Area B; Context 99; Phase 2.

Oxidized Gritty ware

19 Rim and strap handle from chamber pot glazed green. Plot 2; Area B; Context 4; Phase 2.

White Gritty ware

20 Bodysherd from jug glazed green brown and decorated with thumb marks. Plot 1; Test Pit A; Context 10; Phase 1.

21 Bodysherd from green glazed jug decorated with stamped decoration. Plot 1; Area A; Context 273; Phase 1.

22 Bodysherd from jug glazed brown with impressed decoration. Plot 2; Test Pit E; Context 15; Phase 2.

23 Bodysherd from jug decorated with incised lines. Plot 2; Test Pit B; Context 19; Phase 3.

24 Strap handle from jug glazed green brown and decorated with thumb central strip. Plot 2; Test Pit B; Context 17; Phase 1.

25 Sidewalls and base from jug glazed green with two incised lines and a cross. Plot 1; Trench A; Context 168; Phase 1.

26 Sidewalls and base from unglazed jug. Plot 1; Area A; Context 258; Phase 1.

27 Basesherd from unglazed jug. Plot 1; Area A; Context 131; Phase 2.

28 Rimsherd from storage jar with traces of green glaze. Plot 1; Area A; Context 148; Phase 2.

29 Basesherd from cooking pot with traces of external smoke blackening. Plot 1; Area A; Context 150; Phase 2.

East Coast Redware

30 Rimsherd from storage jar glazed brown both internally and externally. Plot 2; Area B; Context 59; Phase 2.

31 Rimsherd from cooking vessel with external smoke blackening and internal green glaze. Plot 2; Area B; Context 100; Phase 2.

32 Bodysherd decorated with stamped squares. Plot 2; Test Pit E; Context 15; Phase 1.

33 Two joining fragments of sugar mould with traces of internal brown glaze. Plot 2; Test Pit D; Context 1; Phase 2.

Reduced Greyware

34 Rim and handle junction from green glazed jug. Plot 2; Area B; Context 59; Phase 2.

35 Rimsherd with handle junction from green glazed jug. Plot 2; Area B; Context 117; Phase 2.

36 Rim and complete strap handle from small jug glazed green internally and externally. Plot 2; Area B; Context 163; Phase 2.

37 Bodysherd from green glazed jug decorated with wavy incised lines. Plot 2; Area B; Context 127; Phase 2.

38 Basesherd from green glazed jug with stacking mark on base. Plot 2; Area B; Context 119; Phase 2.

39 Basesherd from jug. Plot 1; Test Pit B; Context 17; Phase 1.

40 Rim and handle junction from chamber pot glazed green both internally and externally. Plot 2; Area B; Context 100; Phase 2.

Italian Tin-glazed Polychrome

41 Fragment of parrot beak spout glazed blue and white. Plot 2; Area B; Context 75; Phase 3.

42 Strap handle fragment glazed with dark blue black stripes on a white background. Plot 2; Area B; Context 75; Phase 3.

Saintonge Green Glazed

43 Rimsherd from jug externally glazed brown, internally glazed green. Plot 2; Area B; Context 33; Phase 3.

45 Straphandle fragment with spot of external light green glaze. Plot 2; Area B; Context 127; Phase 2.

Unprovenanced French Fabric

44 Bodysherd from jug glazed green with wavy line and incised 'feather' decoration. Plot 2; Area B; Context 33/163; Phase 2/3.

Rhenish Stoneware

46 Frilled basesherd from jug externally glazed dark brown. Plot 2; Test Pit D; Context 1; Phase 2.

47 Bodysherd from *Bartmann* jug with bottom half of bearded facemask. Plot 2; Test Pit B; Context 127; Phase 2.

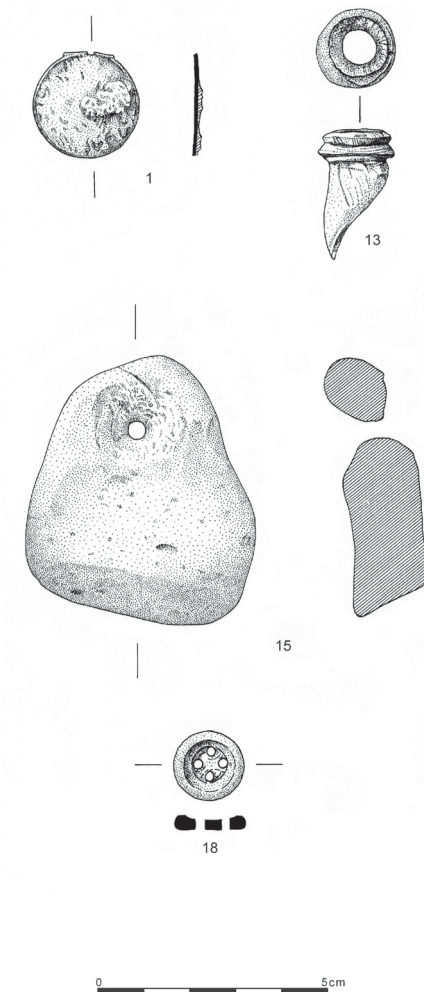

ILLUS 16 94–102 High Street: artefacts

Anglo Dutch Tin Glazed Earthenware

48 Basesherd with footring from open vessel internally glazed light blue and brown with floral decoration and externally glazed light blue. Plot 2; Area B; Context 97; Phase 2.

Donyatt Ware

49 Base and sidewall sherds from open bowl glazed yellow with green glazed sgraffito decoration. Plot 2; Area B; Contexts 97, 161 and 75; Phase 2/3.

Stoneware

50 Basesherd in highly fired black stoneware decorated with panels and leaves. Plot 1; Test Pit A; Context 4; Unstratified.

Wedgwood China (?)

51 Bodysherds from blue glazed vessel decorated with white glazed scene of human figure with dog in sylvan glade. Plot 2; Area B; Context 75; Phase 3.

Unidentified

52 Rimsherd from jug glazed brown on white slip. Plot 2; Test Pit E; Context 15; Phase 2.

OTHER ARTEFACTS FROM 94–102 HIGH STREET

Adrian Cox

A select catalogue of late medieval and post-medieval artefacts is presented and illustrated here (illus 16 & 17). Artefacts from the site evaluation have been included where pertinent to the site interpretation. Measurements are expressed to the nearest millimetre.

Copper alloy objects

Two copper alloy artefacts (Cat 1 and 2) were recovered. Found in a deposit of levelling material associated with a stone building and cellar in Phase 3, Cat 1 probably represents part of a case used to hold a watch or compass. This undecorated example probably dates from the late 18th or 19th century, when it was fashionable for cased watches to be worn on chains. Cat 2 is a narrow thimble of 19th- or early 20th-century date, with mechanically-knurled indentations.

1 Case or lid (illus 16.1). Diameter 47mm; thickness 1mm Plain, circular case or lid in three conjoining fragments, with a shallow rim encircling one face, possibly from a watch or compass casing. Two thin, tangential projections from the edge represent parts of a hinge. Context 2; Find no 15; Phase 3.

2 Thimble. Height 22mm; external diameter at base 17mm Narrow, tapering thimble with a slightly out-turned rim, with fine, mechanically-knurled indentations over its entire surface with the exception of a 3mm-deep band above the rim. (Not illustrated) Modern rubble; Find no 19.

Lead alloy objects

A roughly triangular offcut (Cat 3) was found in make-up below a floor surface in Phase 1. An irregular, heavily corroded fragment of waste sheet (Cat 4) was found in the vicinity of a hearth in Plot 1, Phase 1.

3 Offcut. Length 29mm; width 23mm; thickness 2mm Plain, roughly triangular sheet offcut, with two straight edges and a knife cut in a third. (Not illustrated) Context 231; Find no 8; Phase 1.

4 Waste. Length 21mm; width 19mm; thickness 2mm Heavily corroded, irregular fragment of waste sheet. (Not illustrated) Context 253; Find no 9; Phase 1.

Iron objects

The iron objects from the excavation were recovered in a heavily corroded condition. Several have been subjected to X-ray examination in order to reveal constructional details. Clench bolts, like Cat 5, were used to secure a double thickness of timber. Each consists of a nail which was driven through the timbers, and a rectangular or diamond-shaped plate called a rove, which was placed over the tip of the nail. The nail tip was then clenched to secure it in position. Also from Plot 2, Cat 6 is probably a fragment of a knife blade. Recovered from a dump of 18th- or 19th-century levelling material in Plot 2, No 7 represents part of a knife. No 8, from a clay and rubble deposit in Plot 1, represents part of a tool. Its serrated edge, revealed by X-radiography, indicates that it may have been used in a sawing action rather than for cutting, although the blade shape is more reminiscent of that of a round knife. Pottery recovered from the same context indicates a late 16th or early 17th century date.

5 Clench bolt? Length 63mm; max width of rove 40mm; width of nail head 27mm. Probable clench bolt, consisting of a nail with an irregularly shaped head, and a diamond-shaped rove. The rove has been dislodged and now encircles the nail at mid-shaft. (Not illustrated) Context 2; Find no 21; Phase 3.

6 Knife? Length 84mm; width 19mm; thickness 5mm. Probable knife blade, with a straight back and gently curving edge, broken at both ends. Heavily corroded. (Not illustrated) Context 117; Find no 20; Phase 2.

7 Knife. Length 65mm; max width 20mm; max thickness 13mm. Part of a folding knife or a handle

from a scale tang knife, with bone scales enclosing an iron tang or blade. Two iron rivets survive, securing the scales at either side of the knife. Broken across the position of one of the rivets. Heavily corroded. (Not illustrated) Context 2; Find no 22; Phase 3.

8 Tool. Length 64mm; max width 98mm; max thickness 36mm. Possible saw blade with toothed or serrated edge. Crescent-shaped. Heavily corroded. (Not illustrated) Context 246; Find no 23; Phase 1.

Glass

Both vessel and window glass were recovered. Almost all of the vessel glass is from wine bottles, and it seems likely that some or all of this assemblage is of local manufacture. Dumbarton was at one time Scotland's largest producer of glass. The Dumbarton Glassworks Company was a major employer in the town from the late 18th century until the mid-19th century and its products were traded widely.

Selected vessel glass fragments are catalogued below (Cat 9–13). Catalogue numbers 9 and 10 are bottle bases, both incorporating kick-ups and pontil scars, the latter being where a pontil rod was attached to the base of the bottle during the manufacturing process. Of the two neck fragments from wine bottles described below, Cat 12 is the earlier, being of late 17th- or 18th-century type.

9 Bottle base. Surviving depth 94mm; max diameter 89mm. Base from a bottle in green glass. The high, slightly off-centre kick-up has a central pontil scar surrounded by several small pieces of waste glass. Slight external surface deterioration. (Not illustrated). Context 2; Find no 12; Phase 3.

10 Bottle base. Surviving depth 34mm; max diameter 83mm. Base from cylindrical bottle in green glass. The shallow kick-up has a central pontil scar. No surface deterioration but slight abrasion. (Not illustrated). Context 75; Find no 18; Phase 3.

11 Bottle neck. Surviving depth 53mm; external diameter at rim 27mm; internal diameter at rim 17mm. Neck fragment from a moulded bottle in pale green glass with a cylindrical neck, widening towards the shoulder at point of fracture. Rim is possibly applied. Slight external surface deterioration. (Not illustrated) Context 3; Find no 13; Phase 3.

12 Bottle neck. Surviving depth 92mm; external diameter at rim 32mm. Neck and shoulder fragment from wine bottle of fairly squat form in green glass, with a pronounced string ring below the rim.

Iridescent surface patina. (Not illustrated). Context 104; Find no 17; Phase 3.

13 Bottle neck (illus 16). Surviving depth 53mm; external diameter at rim 32mm; internal diameter at rim 25mm. Neck fragment from blown wine bottle in green glass containing several elongated vesicles. Slight weathering patina on external and internal surfaces. Context 155; Find no 14; Phase 3.

Stone objects

Part of a millstone (Cat 14: illus 17) was reused as a capping stone, set in clay, over a circular hearth in Phase 2. Horizontal water mills were once common in the north and west of Scotland. Such simple, drystone structures, constructed directly over a stream that ran through apertures in the foundations, were commonplace in the Highlands.

Given its size and weight, this fragment cannot have been transported very far from where the stone (with a projected original diameter of c 1200mm) was used, although it is heavily pitted and some parts are quite severely eroded. On the underside of the fragment is an arrangement of slots or grooves, to accommodate the rynd at the top of the shaft or spindle attached to the mill wheel. This is part of an upper millstone and would have been driven directly by the mill wheel. Associated pottery indicates it is of late medieval date.

14 Millstone fragment (illus 17). Surviving length 856mm; max surviving width 589mm; max thickness 80mm. Fragment representing slightly less than half of the original stone, roughly broken across a circular central hole (projected diameter c 200mm). A shallow, raised collar, now slightly eroded, encircles the central hole on the upper face. On the lower face the hole is encircled by shallow, circumferential grooves. A deeper, curved double groove of U-shaped cross-section leads away from the hole. A fragment of an iron object adheres to the underside of the stone. Both upper and lower surfaces are pitted. Context 53; Find no 5; Phase 2.

A roughly triangular, perforated sandstone pebble was recovered during the site evaluation. This object may have functioned as a weight, for example as a loom or net weight, or to secure thatch on the roof of a building. Another possible interpretation is that it represents a so-called witch's stone, hung above the doorway of a dwelling to ward off harmful influences. Such a function has been ascribed to similar objects from Dumfries & Galloway, now in the collections of Dumfries Museum.



ILLUS 17 94–102 High Street: millstone

15 Weight or witch's stone (illus 16.15). Length 111mm; max width 100 mm; max thickness 33mm. Irregular, roughly triangular stone with a circular hole (diameter 8mm), drilled from both sides, below the apex. Site evaluation; Context D:1; Find no 11.

Stone roof slates

Few roof slates were recovered. Catalogue nos 16 and 17 have a roughly circular perforation, drilled from one face only, for attachment to roof timbers by means of a nail or peg.

16 Roof slate. Length 152mm; max width 105mm; max thickness 16mm. Roughly triangular roof slate fragment in fine-grained, micaceous slate, with a roughly circular perforation (diameter 13mm) at the narrower, upper end. (Not illustrated). Context 133; Find no 24; Phase 2.

17 Roof slate. Length 98mm; max width 119mm; max thickness 14mm. Roof slate fragment in fine-grained, micaceous slate, with a roughly circular perforation (diameter 14mm). (Not illustrated). Find no 25; Unstratified.

Shell object

Buttons made from mother-of-pearl, like Cat 18, were manufactured in England and France in the 18th and 19th centuries. Deep-sea shells were imported from Australia, the Philippines and Indonesia for this purpose (Houart 1977, 79–80). This example is probably of early 19th-century date.

18 Button. Diameter 16mm; thickness 2mm. Turned, circular button made from mother-of-pearl, with a central, circular recess in the upper face, into which four circular perforations are set. Lower face is flat. (not illus). Context 2; Find no 10; Phase 3.

Clay pipes

Three undecorated bowl fragments (of which Cat 19 is the most complete) and 19 plain stem fragments were recovered.

19 Bowl. Surviving depth 32mm; max surviving external diameter 20mm; stem bore not measurable. Fragment of a forward-leaning bowl of bulbous form, broken below the rim and across the heel. (Not illustrated). Context 75; Find no 16; Phase 3.

Coins

Two coins of 19th-century date were found.

20 Penny/halfpenny of George III, dated 1806. Copper alloy. (Not illustrated). Context 18; Find no 1; Phase 3.

21 Penny? of Victoria, dated 1865. Heavily worn. Copper alloy. (Not illustrated). Context 2; Find no 2; Phase 3.

THE ANIMAL BONE FROM 94–102 HIGH STREET

Catherine Smith

Faunal remains were recovered both from the site evaluation and the extended excavation at 94–102 High Street. Bones from mammals and birds, and shells of marine mollusca were found. The state of preservation of the bones was unfortunately not good; the marine shells were rather better preserved than the bones, indicating a calcareous soil. Due possibly to adverse conditions of preservation, the quantity of bones recovered was relatively small. Full details of the identification methods are in the site archive.

The total number of bones recovered from each species is shown in Table 3. Remains of cattle and sheep/goats dominated the assemblage; only one bone from a pig was noted. A semi-complete skeleton of a young rat (*Rattus* sp) was recovered from the

TABLE 3
Total numbers of animal bones recovered from Plots 1 and 2, and Test Pit D (94–102 High Street)

	Phase 1	Plot 2 Phase 2	Phase 3	Plot 1	Test Pit D	Total
Cattle		48	24	7	3	82
Sheep/goat		12	3	5	1	21
Pig				1		1
<i>Rattus</i> sp.			*			*
Large ungulate		10	1	1	3	15
Small ungulate		3	4	4	3	14
Indeterminate mammal	2	30	4	10	6	52
Domestic fowl <i>Gallus gallus</i>		1	1			2
Total	2	104	37	28	16	187

* Indicates partial skeleton.

TABLE 4
Composition of flots

Context number	Sample number	Flot volume	Cereal grain	Seed	Charcoal	Slag and cinder	Comments
2	115	<100 ml	+		+	+	Oat +
131	34	<100 ml	+	+	+++	+++	Oat +
133	10	<250 ml			++	+++	
150	19	<250 ml	+		++	+++	Oat +
190	22	<100 ml	++		++	+++	Oat (7), hulled barley (2)
258	32	<250 ml	++		++	+++	Oat ++, barley ++
E9	10	<100 ml		+	+		1 uncharred fig pip
E18	11	<5 ml			+		

Key: + = rare; ++ = common; +++ = common; ++++ = abundant

packing of a wall in a 19th-century building. Two bird bones, both from domestic fowl (*Gallus gallus*), were recovered. Marine molluscs were represented by oyster (*Ostrea edulis*) and cockle (*Cerastoderma edula*) shells.

The pattern of livestock husbandry at Dumbarton indicated a heavy reliance on cattle, and to a lesser extent on sheep/goats. Because of the small sample size it is difficult to determine whether there is any change in the frequency of occurrence of these two species with the passage of time. In Plot 2, the proportions of cattle to sheep are fairly similar in both late medieval/early post-medieval Phase 2 and early modern Phase 3. In Phase 2, comparing only these two species, the percentage occurrences are 80% cattle compared to 20% sheep/goat (based on fragment count). In Phase 3 the frequencies are 88.9% cattle compared with 11.1% sheep/goat. Cattle were killed (or died) at all ages ranging from juvenile to fully mature adult.

Since the numbers of bones recovered was small it is not clear whether there is any pattern in the particular body parts represented. However, all parts of the carcass, including bones which yield much meat and those which bear relatively small amounts of meat, were recovered. Thus the assemblage may be domestic rather than commercial in origin, and represents animals that were eaten.

Evidence of butchery marks on some of the bones indicated that, for the late medieval/early post-medieval Phase 2 material, the main implements used in disjuncting carcasses were axes or cleavers. In early modern Phase 3, although the medieval style

of butchery with the axe continued to prevail, there were several instances in which saws had been used. Although there was no direct evidence for butchery in Phase 1, comparison with other Scottish medieval sites indicates that axes had probably been used. Throughout Scotland, the fleshers' traditional axe continued as the preferred implement for carcass division until the early modern period, when it was gradually replaced by the saw.

THE ENVIRONMENTAL REMAINS FROM 94–102 HIGH STREET

T G Holden

Eight unprocessed soil samples, recovered from a number of cut features outside the building in Plot 1 or in the adjacent plot, and containing a high organic component, were assessed for the presence of environmental and industrial materials. The latter were dealt with separately (see 'The Industrial Soils' below).

In order to assess whether these samples contained 'humic' material, a 0.25ml sub-sample of each was gently wet-sieved. However, the organic preservation of the samples was shown to be poor in all cases. The samples were therefore submitted to flotation and wet-sieving in a Siraf-style flotation machine. The floating debris (the flot) was collected in a 300µm sieve and, once dry, scanned using a binocular microscope (Table 4). Residues were wet-sieved down to 1mm and fully sorted. In view of the industrial character of the retents they were also

tested with a magnet in order to recover hammerscale or other ferrous debris.

Both the flots and retents of most samples were dominated by cinder, with some light, vesicular slag. The retents were particularly rich in this material and substantial quantities of coal were also present. Much of the cinder was evidently from the burning of coal. Heavy vitreous slag was absent. The retents did, however, produce quantities of fine ferrous material (collected by magnet) but none of these contained any hammerscale. Interestingly the magnetic fragments do not appear in Sample E18, a possible cesspit.

Charcoal fragments and occasional cereal grains, including oats and hulled barley, were noted amongst the cinder from the flots. Black oats (*Avena strigosa*, some examples of which were still hulled) were recorded from at least one sample (Context 258). Hulled barley and black oat were the most commonly cultivated cereals in western Scotland until the 19th century and are therefore typical of medieval deposits. The presence of grain in these samples suggests a degree of domestic activity or commercial corn drying in the area. Pottery, glass, burnt bone and heavy mineral concretions were also recovered from the retents.

One sample stands out from the rest. E18 does not have the industrial character of the other samples, consisting mainly of highly degraded organic material with occasional organo-mineral concretions. Concretions such as these would be typical of highly phosphatic waste or cess deposits. The field interpretation as a cesspit is further confirmed by the presence of a single fig seed, an element that often passes through the human gut in good condition and is commonly recovered from archaeological cess deposits.

THE INDUSTRIAL SOILS FROM 94–102 HIGH STREET

E Photos-Jones

Eleven samples were taken from contexts associated with two substantial hearths (124, 125) from within a two-phase building on Plot 1. It was thought they might contain evidence of iron-working, as hammerscale, and also of processed coal or coke. Flotation had already been carried out on the samples; all were examined with a stereo-microscope under low magnification (up to $\times 10$) and three samples (12/120/F, 17/138/1 and 25/233/F) were subjected

to mineralogical investigation with X-ray diffraction (XRD).

Industrial waste in the form of smithing or smelting slag was largely absent from the industrial soils from 94–102 High Street, the only exception being Sample 17/Context 138/1 which contained two small fragments of amorphous slag. On the other hand, charcoal fragments, both heated and unreacted, were ubiquitous. Given the absence of industrial waste proper, attention was focused on the fines and particularly those which were magnetically active.

The samples were characterized by the absence of any macro specimens of metallurgical slag with only one exception (sample 17/138/1) containing two amorphous lumps (c 30mm long axis) probably associated with smithing.

A strong pull to the magnet may or may not suggest the presence of hammerscale, since the iron oxide particles (magnetite) are associated not only with smithing, but also with smelting and other iron-related metallurgical practices. Fines were removed with a magnet from Sample 17/Context 239/F (XRD 1860) and Sample 25/Context 233/F (XRD1861). Sample 17 (XRD 1860) proved to be a composite of iron oxides including wustite (FeO), magnetite (Fe₃O₄), hematite (Fe₂O₃) and some quartz. It is therefore a composite of hammerscale as well as other iron rich components present in smithing slags in particular, interpreted as fines from metallurgical waste.

Sample 25/233/F (XRD1861) was less conclusive in terms of the mineralogical phases present and therefore its identification. Although some magnetite and hematite were indeed present, the peaks are rather weak and suggest the quantities were very small. Furthermore, the spectrum displays the characteristic broad 'hump' that can be attributed to non-crystalline iron oxides. Such iron oxides may be found in earth floors and do not necessarily indicate metallurgical waste.

The majority of the samples contained heated and partially vitrified fragments of charcoal, resembling coke. Occurrence of similar material has been noted in organic industrial waste from other sites in Scotland, such as Woodend, Dumfries (Photos-Jones 1997). Coal is known to have been used by blacksmiths in the Roman period or earlier instead of or in combination with charcoal (Dearne & Branigan 1995). However, the use of processed coal/coke, even in the medieval period, represents a novel idea which will need a considerable amount of research in order to be substantiated.

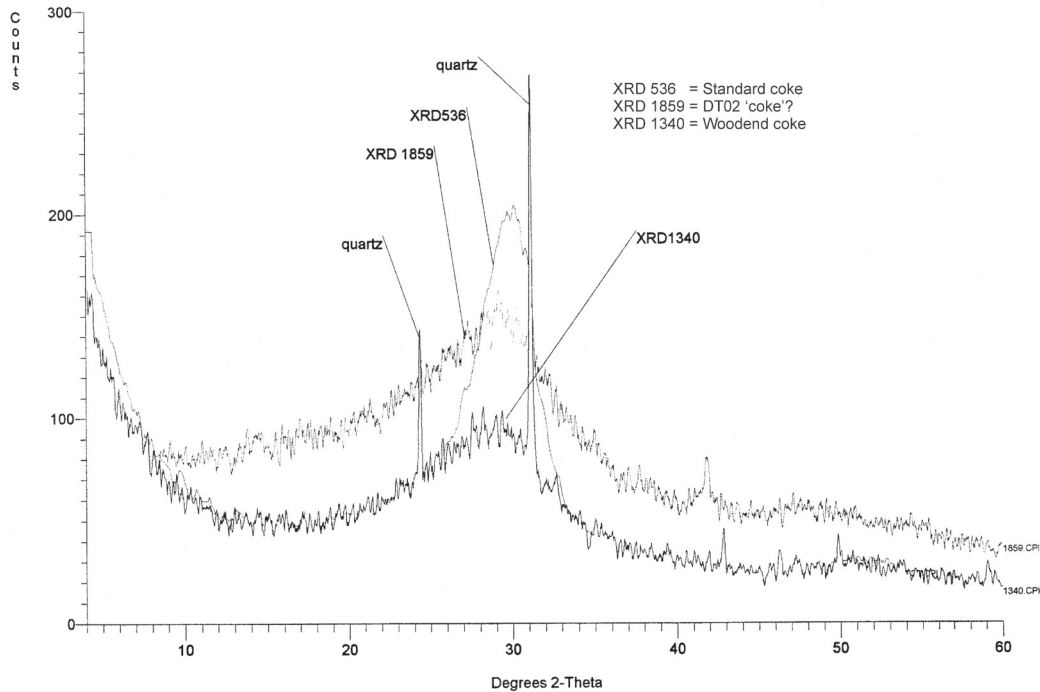

ILLUS 18 XRD spectra of 'coke' samples

The XRD spectrum of the Woodend sample closely matched that of a standard sample known to be coke (illus 18). Morphologically, the Dumbarton samples matched the Woodend samples. However on XRD analysis, Sample 12/Context 120F was not a good match for the standard coke sample. At present it seems necessary to regard the Dumbarton material as vitrified wood charcoal, until more detailed research is carried out on coal from archaeological sites.

Conclusions

Hammerscale can only be securely associated with Sample 17 and less so with Sample 25. Given the very weak pull to the magnet provided by the rest of the samples (Samples 26, 13, 12), it is likely that they may contain no hammerscale.

It was originally suggested that the black, light, frothy, glassy looking material (eg Contexts 120 & 121) resembling vitrified charcoal may have actually been processed coal, or coke. However, XRD spectra did not corroborate such a hypothesis.

The incorporation of charcoal and metallurgical waste into internal floors may well be an accidental

consequence of clearing out hearths. In some cases however these materials may have been intentionally recycled in earthen floors because of their insulating properties. Indeed similar flooring material has been encountered in Scottish Highland Bloomery sites (Photos-Jones et al, forthcoming).

EXCAVATIONS AT 75 COLLEGE STREET, 1971–2

David Perry

Excavations on the site of 75 College Street (Site Code DCS/A) took place over two seasons, in 1971–2, with the permission of Dumbarton Town Council. In the first season a trench some 12m E/W by 3m N/S, was opened up near the College Street frontage, with a northward extension, some 4.5m E/W by 1.2m N/S, to allow the full excavation of a partially exposed feature (Pit 2). In the second season, the original trench was extended some 6m to the north. In both seasons natural sand was reached, at an approximate depth of 0.5m below the modern ground surface.

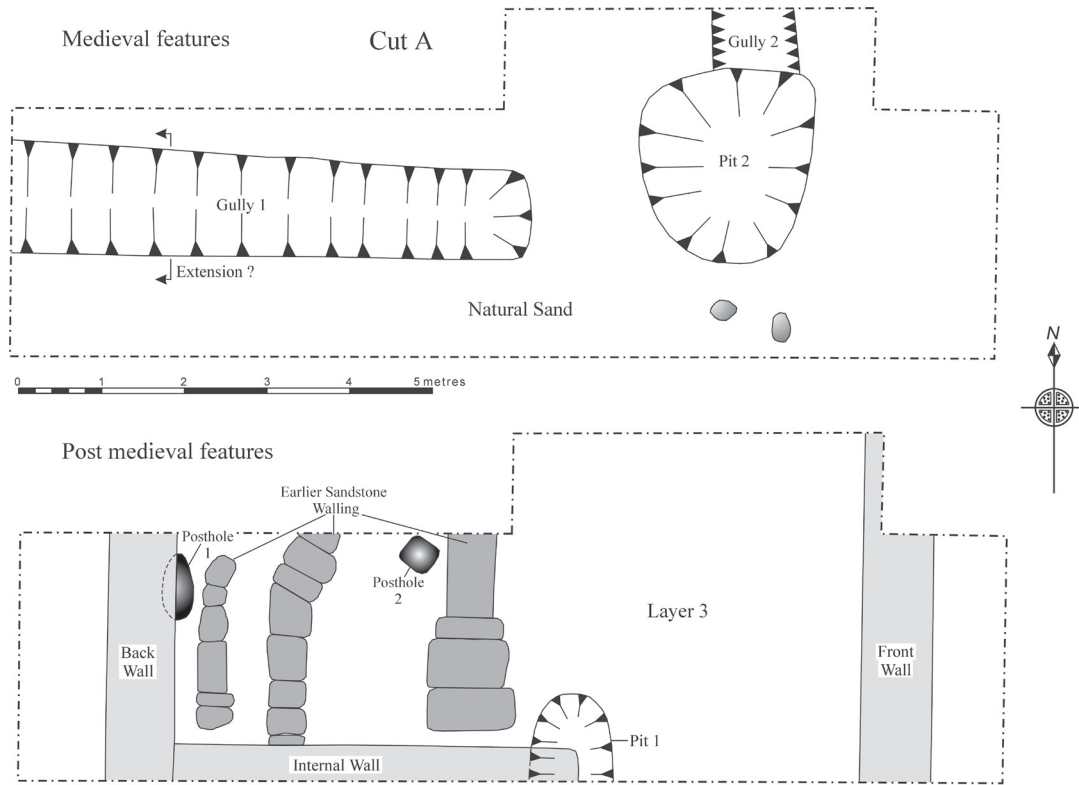

ILLUS 19 75 College Street excavation 1971–2. Cut A, medieval and post-medieval features



ILLUS 20 75 College Street. Medieval features – Gulleys 1 & 2 and Pit 2 (by kind permission of Mr Eric Talbot)

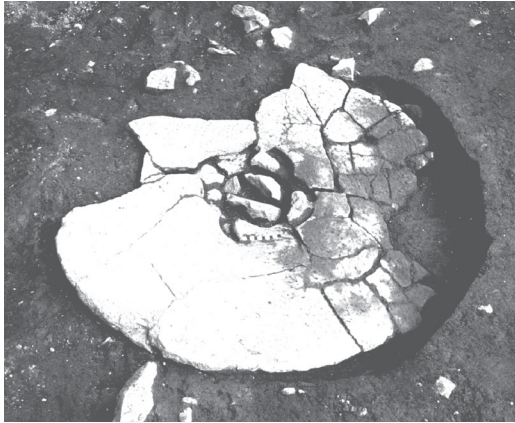

ILLUS 21 75 College Street. Millstone in situ (by kind permission of Mr Eric Talbot)

Five 'levels', probably layers or possibly 'spits', are mentioned in Titmus's (nd) dissertation on the pottery. They were numbered 1–5, 1 being the most recent, 5 the earliest. Her catalogue also refers to Levels 1 and 1a, 2, 2i and 2ii. The basis of these subdivisions is unknown. Unfortunately it is not clear how the four pits (Pits 1–4), two gullies (Gullies 1–2) and two postholes (PH 1–2) relate to these levels. From the available plans and slides, it appears that Pit 1 and PH 1 and 2 were cut into Layer or Level 3, while Pit 2 and Gullies 1 and 2 were under Layer 3. The Level/Layer numbers from the first season were retained during the second season.

THE MEDIEVAL PERIOD (ILLUS 19, 20)

Gully 1 appears to have been the earliest feature uncovered, cut into natural sand. Aligned E/W it was some 6.2m long, 1.4m wide and less than 0.5m deep. Its northern side was steeper than its southern side and it had a flat base. It may have been a boundary ditch from the earliest laying out of the properties at this part of College Street. Only sherds of White Gritty were recovered from this gully, indicating that occupation could date back to the earliest settlement of the burgh in the 13th century, before the introduction of Reduced wares.

Pit 2 was trapezoidal in outline with rounded corners, measuring 2.3m N/S and 1.5–2m E/W. Similarly, it contained only medieval pottery. On its north side, and apparently truncated by Pit 2, was Gully 2, on a N/S alignment. This gully was 1m

wide and at least 0.7m long before extending into the north section. To the south of Pit 2, under Layer 3, was an area of charcoal. Level 5, which contained no pottery (Titmus nd, 18) and Level 4, which contained only medieval pottery (White Gritty and Reduced Greyware), were also probably of medieval date and were presumably under Layer 3.

THE POST-MEDIEVAL PERIOD (ILLUS 19)

Cut into Layer 3 and extending into the south section was the northern edge of Pit 1, about 1m long and 1m wide. Two postholes were also cut into Layer 3. Posthole 1 was oval in outline, about 0.8m by 0.4m. Posthole 2 was squarish, about 0.4m across.

The most recent features on the site comprised at least two phases of sandstone walls. The more recent were the front and back walls of a building, and an internal wall at right angles to the back wall. Within the building were three other walls on a N/S alignment, truncated by the internal wall. The two western walls were parallel and curved slightly towards the east at their north end.

In the second phase of excavation, two pits (Pits 3 and 4) and a shattered millstone were uncovered (illus 21).

Since Level 3 contained more medieval than later pottery, it may have been a medieval layer with intrusive post-medieval finds. Pit 4 contained mainly 17th-century finds, glass bottle shards and a pipe stem of possible 18th-century date. Pit 3 and Levels 1 and 2 contained later finds. Numerous wine bottle shards in Pit 3 and glass waste from the site may have come from the local glassworks, which seems to have owned the site in 1818 (Wood 1818).

EXCAVATIONS AT 101–3 HIGH STREET, 1972

David Perry

The excavation at 101–3 High Street (Site Code DHS/A) took place between April and July and during September 1972 by permission of Woolworth Ltd. A narrow trench, 30m long by 2m wide, was excavated within the backlands of this property, extending from the rear of the building fronting onto High Street frontage and terminating near Riverside Lane (illus 22).

Natural sand and gravel lay at a depth of about 0.8m. The site proved to contain only a relatively



ILLUS 22 101–3 High Street, 1972. General shot with film crew present (with High Street frontage in the background) (*kind permission of Mr Eric Talbot*)

recent levelling deposit, probably associated with the construction of the 19th-century public house on the street frontage. However, this deposit contained almost exclusively medieval pottery probably imported from elsewhere within the burgh.

The designation of Levels 1–4, with Level 2 subdivided into 2, 2a and 2b (Titmus *nd*), suggest that this deposit was excavated in ‘spits’ within the imported soil, Level 1 being the first ‘spit’ (highest and most recent in date), Level 4 the last (lowest and earliest in date). It is not clear if the subdivision of Level 2 into 2, 2a and 2b was made on site or in post-excavation. Moreover, Titmus mentions only Levels 2 and 2a, although her catalogue includes 2b. Finds are recorded from three pits (Pits 1, 2 and C), although she refers only to Pits 1 and C. All pits were presumably contemporary either with the construction or use of the 19th-century building. One of the pits was lined with stones on its north and south sides, with the remnants of a possible stone base. Part of a flagstone floor, presumably of the pub, was also uncovered.

POTTERY FROM 75 COLLEGE STREET AND 101–3 HIGH STREET

Julie Franklin

The large pottery assemblage from Eric Talbot’s excavations spans the medieval to modern periods (illus 23–26). Several problems were encountered

during the writing of the report, primarily the lack of any site records although most of the finds were marked with site codes and context numbers. The context assemblages themselves were of limited help in dating, since most are very mixed and contain some post-medieval material.

The pottery report written shortly after the excavations provides some clues, but not all the contexts mentioned match those marked on the finds (Titmus *nd*). There is also some confusion about site shorthand, whether, for example, DCS 3 and DCS Pit 3 are different or the same contexts. It has been assumed

they are different and that numbers refer to levels except where marked specifically ‘pit’ or ‘posthole’.

In addition, there has at some point been a fire while the finds were in storage and some sherds of pottery are fire damaged. Though not too serious, the paper bags in which they were stored have been burnt away and the sherds rebagged into large mixed bags. Thus a number of sherds with no visible number and no clue from the packaging can now only be counted as unstratified. As well as this a number of finds and pottery were in bags with a different number to that marked on the find. Where this occurs, the number used has been that marked on the find.

Despite these problems the sites did provide a large body of material from an area with little other archaeological work carried out within this date range. The High Street site (DHS) produced a large amount of medieval pottery, including one near complete jug profile, but very little post-medieval material (1264 sherds). The College Street assemblage (DCS) contains few medieval finds, but a good range of post-medieval wares, including some near complete vessels was found (1847 sherds). The fabrics were sorted and identified by eye, and descriptions of form comply with the Medieval Pottery Research Group’s *Guide to the Classification of Ceramic Forms* (1998).

White Gritty ware (Cat 1–2; illus 23) The White Gritty assemblage numbers 496 sherds, over a quarter of the medieval assemblage. Fabric and forms are

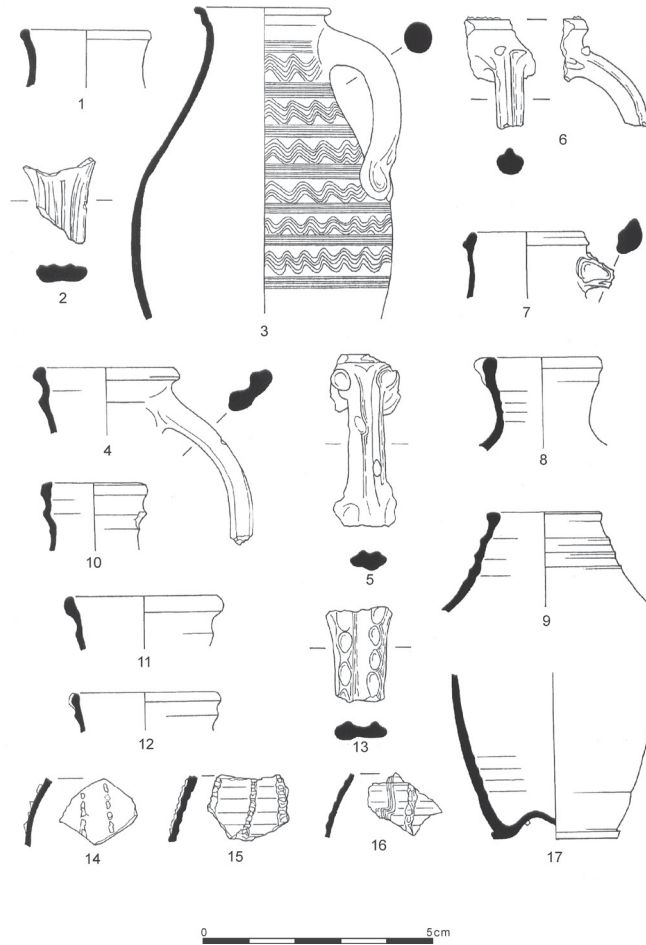

ILLUS 23 75 College Street and 101–3 High Street: pottery

typical; vessels are most commonly decorated with applied-notched strips, combed incised lines and thumbing around the base. Jars are almost completely absent and only a handful of sherds showed any signs of sooting from use as cooking pots. One context ('Gully') from College Street contained only White Gritty ware. Level 4 on the same site contained more White Gritty ware than Reduced ware. This is notable since every other context produced more Reduced Green Glaze ware, raising the possibility of an early exclusively white ware phase.

Reduced Greyware (Cat 3–18; illus 23, 24) The largest fabric group of 1340 sherds is a reduced grey sandy fabric, occasionally with oxidized orange

surfaces, and generally glazed olive green. Two-thirds of these are from the High Street, where they make up 69% of the assemblage. Though similar to the grey and orange gritty assemblage from Ayr (Franklin & Hall, forthcoming), it has more in common both in fabric and form to the tradition of Bothwell Castle, dating from the 13th to the 15th centuries (Cruden 1952, 140). When production started in Dumbarton cannot be known without further evidence. There are no accurate dates from imported sherds, other finds or stratigraphy, but a date sometime in the 13th or 14th century seems likely. It continues into the 16th or even 17th century when it is replaced by or evolves into smooth Post-Medieval Reduced ware. Almost all the sherds

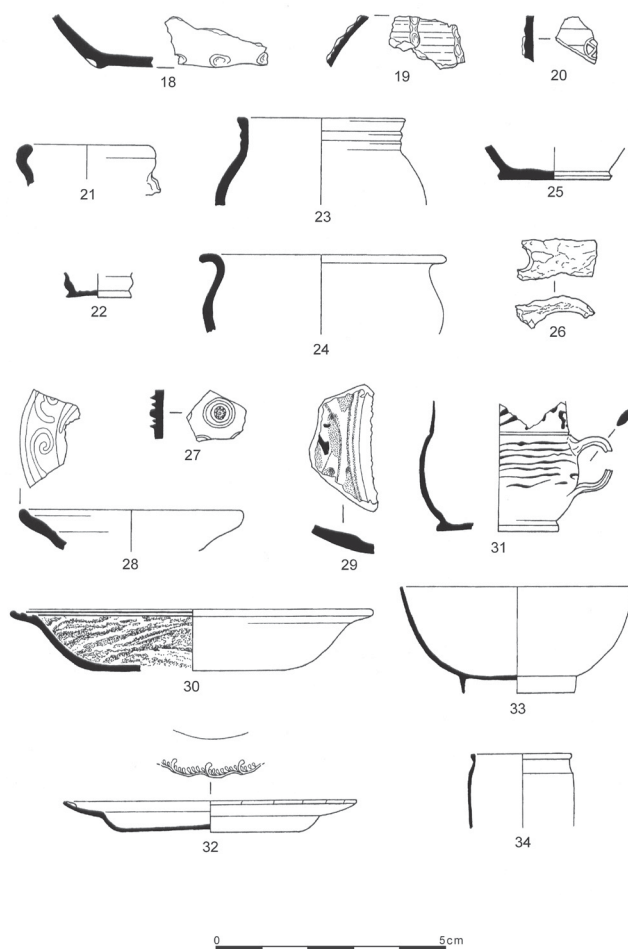

ILLUS 24 75 College Street and 101–3 High Street: pottery

represent jugs. Decoration is most commonly combed incised; the most complete jug profile is covered in alternate bands of straight and wavy comb incising. Such all-over decoration is unusual in Scotland but occurs at Bothwell Castle (Cruden 1952, 154, no 29) and also in Cumbria (McCarthy & Brooks 1988, 221, no 611). The slender shape of the jug and round-sectioned rod handle suggest possible French influence. Applied strips are also a common decoration, usually coloured black and/or notched. Thumbing is used on a few of the bases, and along the edges of two strap handles. These are common medieval decorative techniques, found in similar frequencies at Bothwell. There is one possible waster, a large misshapen base sherd (illus 23.17).

However it may have been usable as a container and should not be taken as proof of a nearby kiln.

?English Imports (Cat 19–20; illus 24) Several sherds from 101–3 High Street could not be identified with certainty. Eight sherds are of a pale coarse sandy fabric, off-white, pale pink or pale grey and covered in a glossy green glaze with copper flecks. Two orange-glazed sherds, both from the same vessel, are of a coarse pink fabric, decorated with applied thumbled strips of slightly redder clay and glazed in a bright orange with greenish patches. A strap handle and body sherd with a metallic purplish-red glaze are in the local reduced fabric, sandy and grey. The glaze is reminiscent of Midland Purple ware, produced



ILLUS 25 101-3 High Street. Saintonge chafing dish found during excavation (*by kind permission of Mr Eric Talbot*)

around the Humber in the mid- to late-15th century (Jennings 1992, 32). One is decorated with an applied stamped wheel pattern. This is an unusual device in Scotland but is found on early Medieval York Glazed Ware (Jennings 1992, 40).

Saintonge Green Glazed wares A small rim and two body sherds in Saintonge Green Glazed Wares were recovered, one from each site and one unstratified. These jugs, associated with the Gascon wine trade, arrived in England from the 13th century (Hurst et al 1986, 76) until at least the 15th (Hurst 1964, 224). Examples have been found in Ayr throughout the medieval period.

Saintonge chafing dish (illus 25) A rim sherd from a facemask chafing dish, now lost, was found during the High Street excavations. It is no longer with the

assemblage and is not mentioned in Titmus' report, though a similar sherd from the Castle is listed. The sherd was photographed and noted by Talbot to be similar to a dish found in Southampton. This was a vessel with low level handles and eight simple knobs, each decorated with a facemask and glazed alternately yellow/orange and green. They were made in southwest and central France during the 16th century (Hurst et al 1986, 80, fig 35.104).

Beauvais Earthenware A sherd of a yellow glazed white earthenware dish with wavy comb incised lines was found at College Street, Level 2. Such dishes were produced in Beauvais, northern France, centring on the first half of the 16th century (Hurst et al 1986, 106). They are more often decorated by sgraffito but a number of sherds of these green and yellow types have recently come to light from sites in south-

western Scotland (Franklin & Hall, forthcoming; Clarke 1997, 515).

Late Medieval Redware (Cat 21–2; illus 24) Forty-four sherds of sandy Redwares came from both sites, glazed either orange or green. Possibly representing vessels imported from the east coast, they include half the base of a small drug jar or cup, a type not commonly seen until the 16th and 17th centuries.

Post-Medieval Reduced Greyware (Cat 24–6; illus 24) Of the 314 sherds found, 289 were from College Street. It is smoother than the preceding sandy reduced ware and similar to pottery produced at Throsk, Stirlingshire in the 17th and early 18th centuries. Though jugs are the most commonly represented vessel, there are two rim sherds from jars, possibly cooking or chamber pots. Bases tend to be flat and about half have a distinctive foot. Decoration is limited to wavy combing.

Loire Jug (Cat 26; illus 24) Handle sherds of two separate Loire jugs were found in College Street Pit 4. They are associated with the wine trade but, due to their small size, are assumed to be containers for less bulky goods, such as olive oil (Hurst et al 1986, 100). They are more common in Scotland than England, no doubt due to the closer links between Scotland and France, and are generally dated from the 16th to 17th centuries.

Spanish Olive Jar One large body sherd from College Street came from a Spanish olive jar. Of a coarse gritty micaceous fabric, red with a buff exterior surface, such vessels were produced around Seville and are found over wide areas of the Americas and north-west Europe. The earliest known are from the late 16th century, the trade continuing until well into the 18th (Hurst et al 1986, 66).

Westerwald Type Stoneware (Cat 27; illus 24) Westerwald type stoneware, with its distinctive cobalt blue glaze, was represented by one College Street sherd, probably from a mug. Such stoneware has been imported into Britain from the early 17th century and is still produced today but the stamped decoration is among the earliest used (Jennings 1981, 123).

Slipware (Cat 28; illus 24) A rim sherd from a slipware dish found at College Street was probably made in England or Holland in the 17th century (G Haggarty, pers comm).

Tin Glazed Earthenware (Cat 29; illus 24) Sixteen sherds of tin glazed earthenware were found at College Street. The largest of these was part of a plate, of a pale pinkish-orange fabric, painted with a blue design. The remainder were of pale cream fabric, mostly from flat wares, except for three sherds, of small hollow vessels, possibly drug jars. Production of these wares centred in the 17th and 18th centuries in the Netherlands and England (Jennings 1981, 187).

The College Street Dump (Cat 30–42; illus 24, 26–7) A large collection of later sherds and several near complete vessels made up half of the College Street assemblage. These were concentrated in Pit 3 and Level 2 but sherds were spread through most features, with many adjoining sherds found in separate contexts. The number of near complete vessels, especially when compared to the collection of earlier small sherds implies they were dumped in situ. They fell into two main date ranges, a small group from the late 17th century and the rest from the late 18th and early 19th centuries. Not enough is known of the types of wares being produced in Glasgow and the rest of Scotland at this time to be able to claim a local origin. Most are assumed to be of English manufacture, unless otherwise suggested. The earlier group consists of an agate-ware dish and a few sherds of white-bodied slipware, including a near complete single handled jar (probably a chamber pot). Both date to around 1690. The bulk of the pottery comes from the late 18th and early 19th centuries. The finest of the wares is a large collection of 232 sherds of creamware, comprising several feather edged plates, several bowls, a jar and a tea- or chamber pot handle. There is also a piece of a hand painted pearlware dish or bowl. Most of the slipware came from three or four large bowls decorated with the same simple design in white slip over a red body. The unusual form, simplicity and frequency of these bowls suggest they may have been produced in Glasgow. They date to about 1790 or 1800. The rest of the slipware is more fragmentary, but all are red bodied with simple designs in white slip, appearing of approximately the same date. A slip-lined bowl is decorated with splashes of green and brown colouring added to the glaze. These were being produced at West Pans near Edinburgh in about 1780 or 1790, but it seems more likely that this came from a closer source. Much of the group was of large, coarse utilitarian vessels, one of stoneware, most of red earthenware. Most of these appear to be from large jars, glazed either orange or black. These

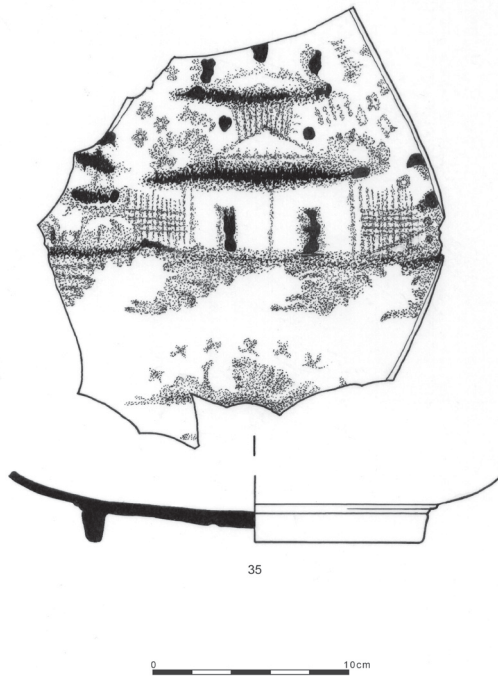

ILLUS 26 75 College Street and 101–3 High Street:
pearlware/dish base

vessels are more likely to be of local manufacture as, being less desirable, they are less likely to travel. This is a relatively low status assemblage with mostly utilitarian wares and few finely decorated vessels or porcelain.

CATALOGUE OF ILLUSTRATED SHERDS FROM 75 COLLEGE STREET AND 101–3 HIGH STREET

White Gritty ware

- 1 Jug rim. Patchy olive glaze. DHS. 2.
- 2 Jug handle. Ridged and grooved decoration, patchy olive glaze. DHS. 2.

Reduced Greyware

- 3 Jug profile. Combed decoration. Thin patchy glaze. DHS. 2a.
- 4 Jug rim and handle. Thin patchy olive glaze. DCS. Pit 2.

- 5 Jug rim and handle. Patchy olive glaze. DHS. 2.
- 6 Jug rim and handle. Applied pip decoration, stacking scar on rim, patchy olive glaze. DHS. 2a.
- 7 Jug rim and handle. Possibly was glazed, none remaining. DCS. 1.
- 8 Jug rim. Patchy flaking glaze. DHS. 2.
- 9 Jug rim. Thin patchy dark glaze. DCS. 3.
- 10 Jug rim. Patchy olive glaze. DHS. 2a.
- 11 Jug rim. Thin patchy olive glaze. DHS. 2.
- 12 Jug rim. Patchy olive glaze. DCS. 4.
- 13 Jug handle. Thumbed decoration, olive glaze on outside. DCS. 3.
- 14 Body sherd. Applied scale decoration, thin flaking olive glaze. DHS. 4.
- 15 Body sherd. Applied notched black strips, olive glaze. DHS. 2a.
- 16 Body sherd. Applied thumbed black strip and combing, olive glaze. DHS. 2.
- 17 Jug base, possible waster. Metallic brown glaze, possibly burnt. DCS. Pit 4.
- 18 Base. Thumbed decoration, flakes of olive glaze remaining on wall. DHS. 2.

?English Imports

- 19 Body sherd. Coarse gritty pink fabric, applied thumbed red strip decoration, clear glaze with patches of olive, appearing orange over body, brighter orange over decoration. DHS. 2a.
- 20 Body sherd. Grey sandy fabric, applied stamped decoration, patchy metallic purplish red glaze. DHS. 2.

Late Medieval Redware

- 21 Jug rim. Patchy olive glaze. DHS. 3.
- 22 Small jar/cup base. All over interior blackened glaze, patchy on exterior walls. DCS. 3.

Post-Medieval Reduced Greyware

- 23 Jar rim. Flaking olive glaze, internal and external. DCS. 3.

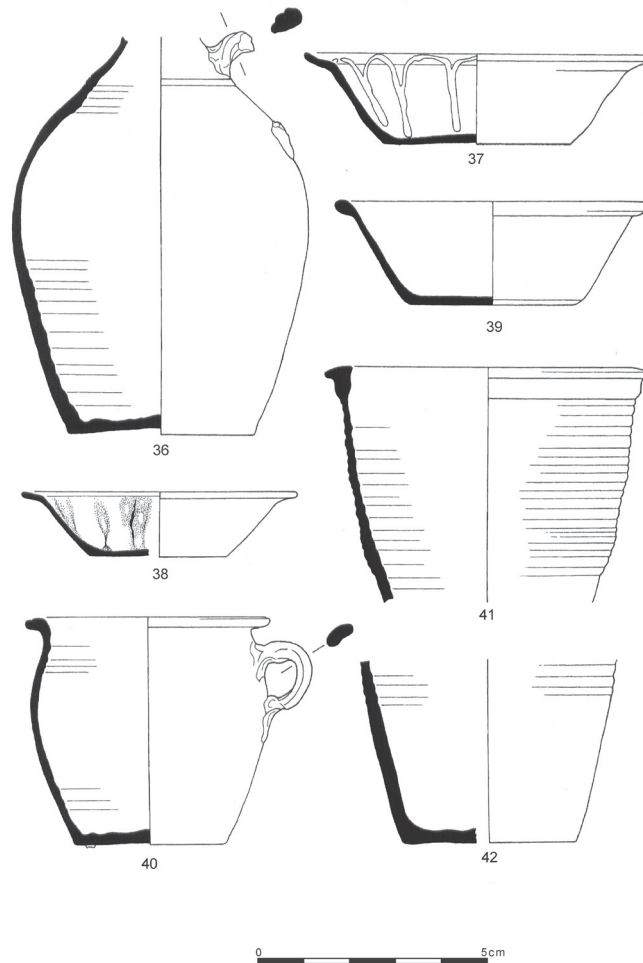

ILLUS 27 75 College Street and 101–3 High Street: pottery

24 Jar rim. Olive glaze, internal and external. DCS. Pit 3.

25 Base. Patchy flaking olive glaze, internal and external. DCS. 3.

Loire Jug

26 Rim and handle. Flaking fabric, unglazed. DCS. Pit 4.

Westerwald Type Stoneware

27 Body sherd. Applied stamped decoration, coloured pale grey, against blue ground. DCS. 3.

Slipware

28 Dish rim. White slip decoration over red body, glaze flaking and discoloured. DCS. 3.

Tin Glazed Earthenware

29 Dish sherd. Pink fabric, tin glazed white with fabric colour showing through in places, hand painted in blue and dark blue. DCS. 3.

The College Street Dump

30 Agate ware dish. Body of mixed red and white clay, giving marble effect. Rim covered in white

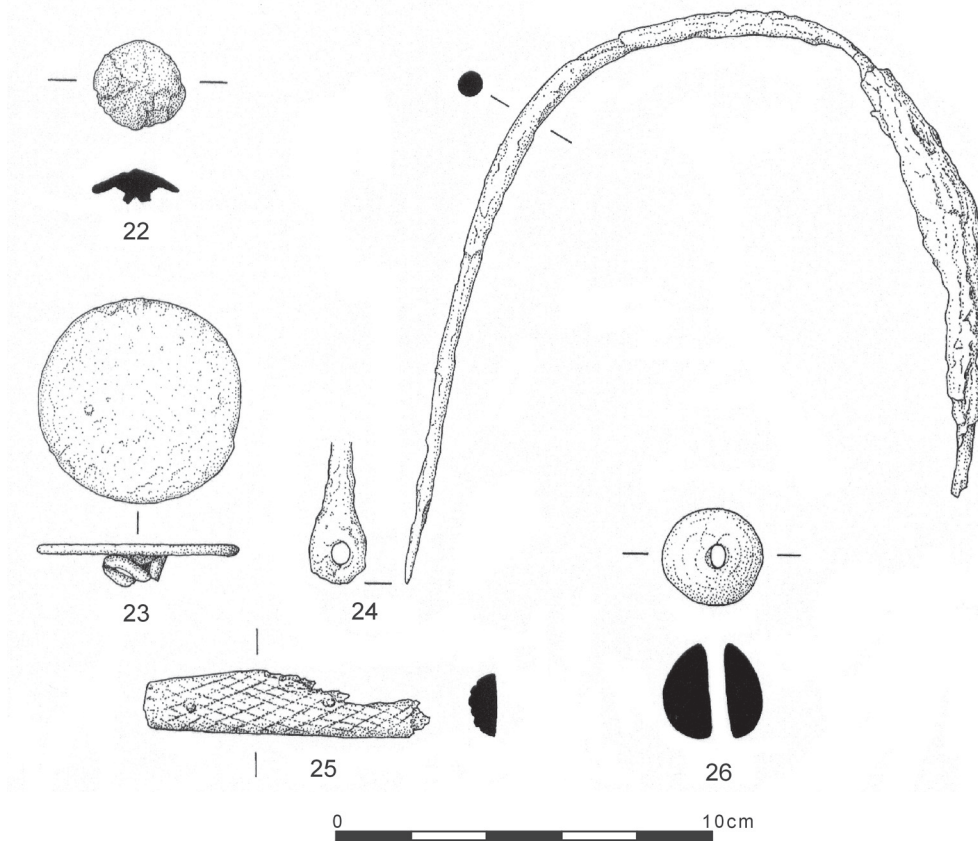

ILLUS 28 75 College Street and 101–3 High Street: artefacts

slip with two sgraffito stripes. Glazed all over except bottom of base, showing brown and yellow. c 1690. DCS. 2, Pit 3, one sherd marked DHS 1.

31 Slipware handled jar. Off white body with combed brown slip decoration. Glazed on exterior except lower walls and base, all over glaze on interior, showing brown on yellow. c 1690. DCS. Pit 4, 2.

32 Creamware plate. Feather edged decoration. c 1790. DCS. Pit 3.

33 Creamware bowl. c 1790. DCS. Pit 3.

34 Creamware jar. DCS. Pit 3.

35 Pearlware bowl/dish base. Hand-painted decoration, blue and dark blue. Late 18th-early 19th century. DCS. Pit 3.

36 Stoneware jug. Coarse grey fabric, all over external brown salt glaze. DCS. Pit 3.

37 Slipware bowl. Red bodied, decorated with white slip. Glazed all over interior, showing yellow on reddish brown. 1790–1800. DCS. 2.

38 Slip-lined bowl. Red bodied with interior white slip lining. Clear glaze all over interior, showing cream, with patches of green and brown colouring in glaze. 1780–90. DCS. Pit 3.

39 Slip-lined bowl. Plain red bodied bowl with interior slip lined and glazed, showing cream. DCS. Unstratified.

40 Earthenware handled jar. Red sandy fabric, interior glaze, thin in places, showing orange with brown mottles. c 1800. DCS. Pit 3, 2, 1.

41/42 Earthenware jar. Coarse red fabric with black manganese/iron glaze. Glazed on exterior except lower walls and base, all over glaze on interior. DCS. 2, 1, Pit 3.

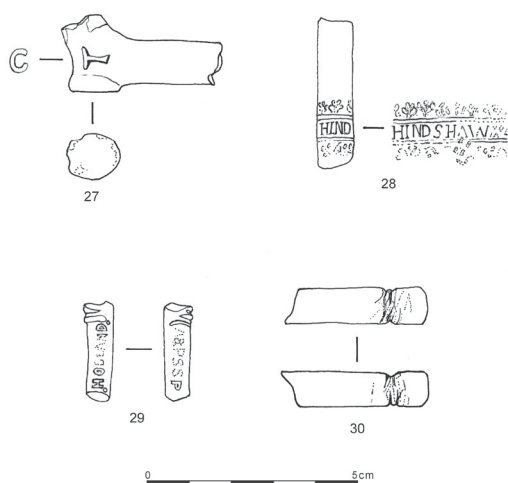

ILLUS 29 75 College Street and 101–3 High Street: artefacts

OTHER ARTEFACTS FROM 101–3 HIGH STREET AND 75 COLLEGE STREET (ILLUS 28–30)

Julie Franklin

The storage problems affecting the pottery (above) also adversely affected the other artefacts. Metalwork especially has suffered from poor preservation, both pre- and post-excavation. Non-ferrous metalwork is sparse and none is attributable with any certainty to the medieval period. Some of the iron finds have turned to dust in their bags. Despite these problems the sites did provide a large body of material from an area with little other archaeological work carried out within this date range.

Copper alloy objects

The finds of non-ferrous metal, all from College Street, were poor in quality and quantity. None were diagnostic and few were even recognizable. One button is possibly attributable to the medieval period, another is certainly post-medieval.

22 Button (illus 28). Small conical shaped with remains of a wire loop fastening at the back. Diameter 12mm, depth 3mm. DCS. Pit 3.

23 Button (illus 28). Flat disc with wire loop fastening at back. Diameter 28mm, thickness 2mm. DCS. 1.

Iron objects

The iron was all in very bad condition due to its time spent in paper bags. There are no objects which

definitely date to the medieval period, although it is likely that the High Street finds, from their associations with the pottery, are medieval. These numbered only a few nails, and unrecognizable lumps and strips. One triangular sectioned strip was probably part of a knife blade, but lacked either point or tang. A bucket handle from College Street is possibly of some age. Again, pottery associations mean it is most likely to date between the late 17th and early 19th century. Other objects are all obviously modern or unrecognizable.

Nails make up most of the assemblage. The largest group of nails are long, generally over 100mm, with small pointed rectangular heads and, originating only from College Street, are certainly post-medieval. Shorter nails with large square heads are the norm for earlier deposits.

24 Bucket handle (illus 28). Round sectioned rod of iron bent into a broad U shape. The one remaining terminal is rounded and flat with a central hole. There are 20 fragments present from the other terminal. Height 170mm, width 150mm. DCS. U/S.

Other finds

25 Bone scale from a two-part implement handle (illus 28), with iron rivet at narrow end, decorated with deeply incised cross hatching. Length 76mm, width 17mm, thickness 7mm. DCS. Pit 3.

26 Glass bead, transparent blue (illus 28). Diameter 14mm, length 13mm, hole 2mm. DCS. 3.

Clay pipes

Eight of the 40 clay pipe pieces were marked and were identified, (unless otherwise stated) following Davey (1987). Almost all came from College Street. The earliest were two late 17th to early 18th century pipes by Glasgow makers James Colquhoun and the Hyndshaw family. There is no record of any pipe makers working in Dumbarton and the predominance of Glasgow pipes here bears this out. There was also a fragment of stem from a 17th-century Dutch pipe, marked 'HOLLAND'. A pipemaker called Jan Pietersz Holland was working in Gouda in 1648 (Duco 1981, 321), though whether he marked his pipes thus is not known. The only other foreign pipe was from Cork, of 19th century date (Higgins 1981, 228). The rest, including the only marked pipe from the High Street, were from 19th and early 20th century Glasgow makers John Waldie, Hugh Divine,

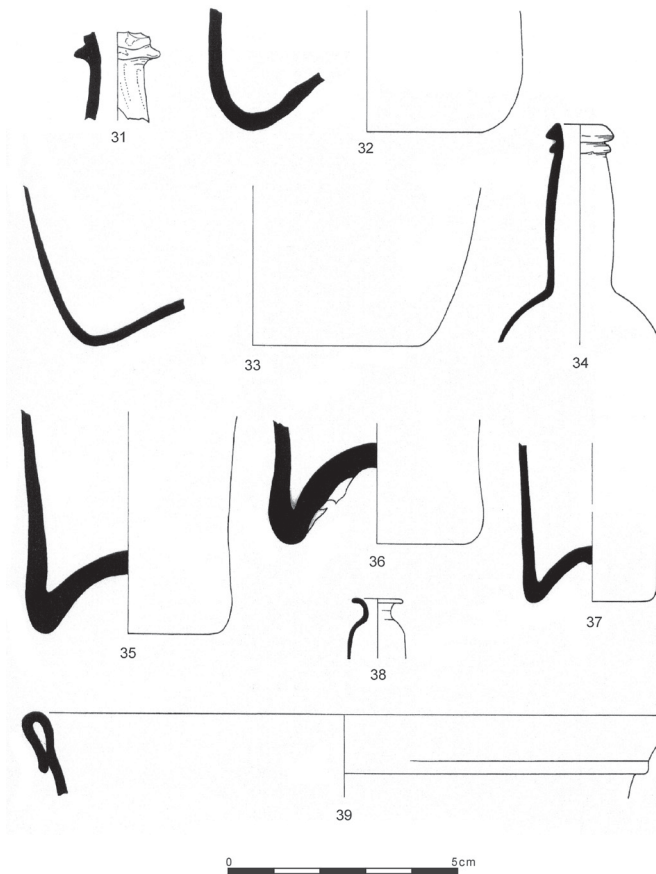

ILLUS 30 75 College Street and 101–3 High Street: artefacts

William Murray, and John Boyd, all with names stamped on the stem.

27 Stem and heel with relief moulded initials 'IC' (illus 29). James Colquhoun, Glasgow, 1660–1730 DCS. 2.

28 Stem with roller stamped band bearing lettering '?HINDSH-W' (illus 29). William/Samuel Hyndshaw, Glasgow, 1674–1734. DCS. 2.

29 Stem with relief moulded decoration and lettering 'A & P.S.SP'/'-HOLLAND' (illus 29). Dutch, possibly Gouda, 17th century. DCS. 2.

30 Stem deeply scored around middle, possibly for use as a wig curler or bobbin (illus 29). 17th/18th century. DCS. Pit 4.

Glass

A large quantity of glass (246 sherds) came almost exclusively from College Street (illus 30). None dates to before the 17th century and most were from wine bottles. These were especially numerous in Level 2 and Pit 3 and ranged from the late 17th to 19th century, agreeing with the pottery dates from these contexts. A small phial and the base kick of another probably date to the 17th or 18th century. There was also a small amount of modern window glass.

Two rims were apparently from bowls or jars. Both were of olive green glass about 25cm in diameter, made in the same way, by folding a strip down over the outside of the rim. A similar sized bowl of dark glass, though with a simple rim, was found in Norwich, and a folded rim of smaller size from a decorated pale glass jar is also shown. Both date to the

early 17th century (Haslem 1993, 109). However the presence of two vessels of such an unusual form could mean they were products of the later Dumbarton Glassworks, which was operational from 1777 until 1850 (Turnbull 2001, 291). Little is known of the kind of glasswares it produced, but some of the late 18th and early 19th century bottles as well as 26 pieces of glass waste could have originated there.

Wine bottles

31 Neck fragment. Down tooled string rim, olive green. Late 17th-mid 18th century. DCS. Pit 4.

32 Base. Deep kick and rounded walls, olive green. Early 18th century. DCS. Pit 4.

33 Base. Rounded kick, with straight outward sloping walls, olive green. Late 17th-early 18th century. DCS. 2.

34 Neck. Convex neck with mouth down tooled over string rim and rounded shoulders, olive green. Late 18th-early 19th century. DCS. 2.

35 Base. Domed kick and outward sloping walls, olive green. Mid-late 18th century. DCS. Pit 3.

36 Base. Complete base with conical kick, badly made with adhering glass fragments from pontil rod inside kick, olive green. Mid-late 18th century. DCS. 2.

37 Base. Small base, machine made with shallow conical kick with central nipple and straight sides, amber to olive green. 19th century. DCS. 2.

Other vessels

38 Neck of small phial. Short neck and flat rim, very pale green. 17th/18th century. DCS. Pit 4.

39 Bowl rim. Wide folded rim, olive green. 17th/18th century. DCS. 1.

ANIMAL BONE FROM 101–3 HIGH STREET AND 75 COLLEGE STREET

Catherine Smith

As noted in the pottery report (Franklin, above) some fire damage had occurred to the original packaging in which the finds from 101–3 High Street (code DHS/A) and 75 College Street (DCS/A) were stored; a further code appears to have been allocated to mixed material which has been treated as unstratified (DMLO).

Preservation of the animal bones from both sites varied considerably from context to context. The material from 101–3 High Street was in slightly better condition than that from College Street, and suffered from less abrasion and post-depositional damage.

Species present

The bones were mainly those of domesticated livestock. At 101–3 High Street, cattle, sheep/goat, goat, pig, horse, dog and domestic fowl (*Gallus gallus*) were present. At College Street, the range of species was restricted to cattle, sheep/goat, pig, horse and rat (*Rattus*) species. This last was more likely to have been the brown rat (*Rattus norvegicus*) than the black rat (*R. rattus*). A cattle phalange from the same context at College Street which contained the rat bone showed the characteristic pattern of rodent tooth marks.

Cattle and sheep/goat bones were, however, the most numerous of all the species found at the two sites, as at 94–102 High Street. One fragmentary skull with horn cores was positively identified as goat. The numbers of bones from each species are shown in Table 5 along with a summary of the percentage frequencies of the main food-forming mammals (Table 6). Comparison may be made with sites of known medieval date on the east coast of Scotland, at which cattle outnumber sheep/goats almost without exception (Hodgson 1983). Similarly, pig bones are relatively scarce. Although commonly kept in burgh towns in the medieval period, pig remains are never frequent in Scottish archaeological assemblages. This is partly because the presence of large numbers of cattle and sheep brought into the burghs for slaughter and sale masks the presence of pigs (Smith 2000). Based on mandibular tooth wear and epiphysial fusion evidence, more cattle than sheep/goats survived to maturity, and more young pigs were killed than either of the other two species.

Horse bones were present at both 101–3 High Street and College Street, but absent from 94–102 High Street. A single bone of dog was noted in the 101–3 High Street assemblage; none was recovered from College Street or 94–102 High Street. One domestic fowl bone was recovered from 101–3 High Street, compared with two bones from 94–102 High Street and none from College Street. This is perhaps an indicator of a low recovery rate of small fragments, not unsurprising since soil sampling was not undertaken.

Shells of marine molluscs were also recovered. Oysters (*Ostrea edulis*) were recovered from both

TABLE 5
Total number of bones from 101–3 High Street (Site DHS/A), 75 College Street (Site DCS/A) and mixed sites (DMLO, DHS/A, DCS/A)

<i>Species</i>	<i>Number of bones from each site</i>		
	<i>101–3 High Street</i>	<i>75 College Street</i>	<i>Mixed material</i>
Cattle	136	42	58
Sheep/goat	40	19	33
Goat	1		
Pig	9	3	2
Horse	13	1	2
Dog	1		
Rat (<i>Rattus</i> sp)		2	
Large ungulate	42	3	6
Small ungulate	3	28	6
Indeterminate mammal	209	77	70
Domestic fowl (<i>Gallus gallus</i>)	2		
Indeterminate bird	1		
Total	457	175	177

College Street and 101–3 High Street. Fragments of mussel (*Mytilus edulis*) and wulk/periwinkle (*Littorina littorea*) were found in the 101–3 High Street assemblage.

Butchery evidence on the bones

Evidence of marks made by butchery implements on the bones of cattle, sheep/goat and pig indicates that the tools used most frequently were axes or cleavers.

In addition, bones of these animals retained evidence of cuts made by metal knives.

Three bones had been sawn. Two probably came from cuts of mutton equivalent to the modern gigot chop while a horse metapodial or cannon bone from College Street, sawn medio-laterally across the shaft near to its distal articulation, was probably an offcut from artefact manufacture (DCS/A 2). Horse metapodials possess relatively straight and thick-

TABLE 6
Numbers and percentages of main food-forming mammals at sites in Dumbarton, based on fragment count

	<i>Dumbarton High Street (DHS/A)</i>		<i>Dumbarton College Street (DCS/A)</i>		<i>Dumbarton 94–102 High Street, Area B (DT01/DT02)</i>	
	<i>n</i>	<i>%</i>	<i>n</i>	<i>%</i>	<i>n</i>	<i>%</i>
Cattle	136	68.3	42	64.6	72	82.8
Sheep/goat	40	20.1	19	29.2	15	17.2
Goat	1	0.5		*		
Pig	9	4.5	3	4.6		
Horse	13	6.5	1	1.5		
Total	199	99.9	65	99.9	87	100.0

Note: * indicates that sheep and goat percentages are expressed as one figure. Mixed material from DCS/A and DHS/A (code DMLO) has been omitted from this table.

walled shafts which make them an ideal source of relatively long, strong bone pieces which can be formed into handles, gouges, etc.

Size of animals

No complete cattle long bones survived, so it was not possible to estimate withers heights for this species. However, comparison of the available breadth measurements with those from medieval urban sites indicate a conformity with other Scottish populations, although, to date, no significant difference in size has been detected between animals of medieval and post-medieval date. Similarly, there was no evidence of large, modern sheep.

Two bones from small ponies estimated to stand at about 12:3 and 12:1 hands height (129.5cm and 126.2cm) were found at 101–3 High Street. A review of medieval horse heights has shown that no animal of above 14:2 hands has so far been recovered from a Scottish medieval urban site (Smith 1998).

DISCUSSION

THE ARTEFACT AND POTTERY ASSEMBLAGES FROM DUMBARTON

Julie Franklin, Derek Hall & Adrian Cox

The Dumbarton pottery assemblages are of great interest for Scottish medieval pottery studies. First, it is very rare to find urban deposits of late medieval date in Scotland, as they have normally been destroyed by extensive Victorian or modern development. Second, one of the largest gaps in our knowledge of Scottish medieval pottery concerns local industry and the range of imported wares on the west coast. This assemblage goes some way to addressing both these problems.

The assemblage is dominated by variations of a gritty ware assumed to be made locally. White Gritty is generally defined as an east coast Scottish product, though it is found on a number of west coast sites, for example, forming 17% of the medieval assemblage from Ayr (Franklin & Hall, forthcoming). On these sites it decreases in volume as the local Reduced ware industry

takes over. Whether it was actually produced in the west is a bone of contention, though in view of the volume of material found it seems likely. Recent chemical analysis of Scottish Gritty wares by the British Geological Survey has indicated that production sites may have existed on the west coast (Will et al, forthcoming).

A variety of stamped and incised decorations found on gritty wares at 94–102 High Street may indicate either owners' or makers' marks. These wares were found in association with imported pottery dating to the early to mid-1600s and exemplify the style and form of late medieval pottery on the Scottish west coast.

The pottery from Eric Talbot's excavations is the only demonstrably medieval material from either site. None of it can be placed with certainty in the 13th century, though there is no reason why the earliest pottery could not be contemporary with the foundation of the burgh in 1222.

It is of limited use to try and reconstruct the stratigraphy of these sites. The margin of error resulting from badly-labelled finds, unknown contexts and unknown excavation techniques is too great. However, some patterns do emerge from the complete artefact and pottery assemblage. Almost all the material from 101–4 High Street excavation was medieval, though only Level 2a and Pit C escaped later contamination. The near complete jug profile from Level 2a may have been deposited in situ, though how it relates to Levels 2 and 3 with their 19th-century intrusions is unknown. The site's High Street location, and the pottery and other finds evidence, suggest that the deposits date from around the foundation of the burgh and that very little was laid down after the early 17th century.

The absence of medieval English imports from College Street could imply a later start date for deposits there when compared with the High Street. This could, however, merely be a factor of the lower status of areas behind the High Street. The contexts containing White Gritty (Level 4 and Gully) at College Street may

in fact be the earliest, but without further dating evidence this cannot be certain. College Street Pit 2 also contains only medieval material. Most of the finds from Level 3 are medieval, though it also contains the bulk of the 17th-century material. Pit 4 is mostly 17th century. Levels 1, 2 and Pit 3 contain most of the later finds, including most of the clay pipes and glass.

There are some apparent gaps in the College Street sequence, particularly for the mid-17th and mid-18th centuries. There is no glass from before the late 17th century and no clay pipes dating earlier than 1660. Likewise, the expected pottery from the mid-18th century is not present. The completeness of the later pottery implies it has been dumped *in situ* and in two distinct phases, one in the late 17th century and one in the late 18th to early 19th century. Possibly this represents two phases of infilling to raise the ground level against the threat of flooding.

The pattern of imported pottery at Dumbarton is typically west-coast. There are no Yorkshire wares, the most common medieval import on the east coast, no Dutch wares and only one fragment of Rhenish stoneware. Instead, France, England and Spain provide most of the imports, reflecting the cargoes of wine, olives and olive oil transported within them. Similarly at Ayr and at a number of other west coast sites most of the imports were French (Cruden 1952; Dunning 1968; Clarke 1997; Franklin & Hall, forthcoming). Only Paisley Abbey differs, the only imports there being stoneware (R Will, pers comm). The high quality of the imported wares at Dumbarton reflects the former status of the burgh.

Another west-coast trend is the predominance of jugs. The proportion of jugs to jars increases during the medieval period; lack of jars is generally taken as a sign of a later assemblage as metal cooking pots become more widely available. In Ayr, too, there was a relative dearth of jars. Possibly metalwork was generally easier to come by on the west coast, from trade links up the Irish Sea from the copper and tin mines of south-western England. Certainly some large

hauls of metalwork have been found in the west, for example at Lochmaben and Threave Castles (Macdonald & Laing 1975; Good & Tabraham 1981). The apparently later start of the pottery industry in the west, compared to the 12th-century dates of the Border Abbeys (Tabraham 1984; Haggarty & Will 1995) may reflect an acceleration of supply and demand for bronze and iron cooking wares, rather than a lagging behind of demand for pottery vessels.

The artefact assemblages provide evidence mainly of post-medieval activity, although there is also limited evidence of lead alloy-working in the late medieval period at 94–102 High Street and a millstone fragment from this site also appears to be of late medieval date. Although it had been reused as capping for a hearth, the millstone is a rare and important find in an archaeological context.

These excavations produced a moderately large amount of glass. Particularly abundant were the remains of wine bottles. Some of this glass and glass waste material could have originated from the Dumbarton Glassworks, established in 1777 to the north-west of College Street. In 1818 the company may have owned the site at College Street (Wood 1818). Glass manufacture was a major industry in the burgh at this time. Other artefacts of interest also date from this period, for example the watch or compass casing from 94–102 High Street.

THE ANIMAL BONE FROM DUMBARTON

Catherine Smith

At urban sites of medieval date on the north-east coast of Scotland, cattle generally dominate over sheep/goat (see for example, Hodgson, 1983). Since little prior work has been done on animal bones from the west coast of Scotland, the Dumbarton material has proved a valuable comparison.

At Glasgow Cathedral Square (Smith, unpublished), it has been found that, as at Dumbarton, cattle were more frequent than sheep. Similarly, at sites in the north-east of

Scotland, for example in Perth and Aberdeen, cattle were also the more important of the two. By contrast, in the Borders, for example in medieval and post-medieval Peebles, sheep were relatively more common (Smith 2002). The differences in the proportions of cattle to sheep probably indicate the importance of the cattle-hide trade in the north-east and west of the country, while in the Borders, the emphasis was on wool.

Dumbarton's status as a royal burgh meant that the town enjoyed economic privileges, which included trading rights over an extensive rural hinterland. The livestock which were traded at its weekly fairs, and on which tolls and customs were levied, would have been raised in this hinterland (Dennison & Coleman 1999). Domestic animals, in their roles as producers of skins and hides, were still of great importance to the local economy in the later 17th century (*ibid*). The bones from the site may represent animals which were part of this trade in livestock.

DISCUSSION OF THE EXCAVATIONS

The first two excavations in Dumbarton, undertaken by Eric Talbot in 1971 and 1972, were considered disappointing at the time even by their excavator, whose previous experience had been as City Archaeologist in King's Lynn. Nevertheless, these were two of the earliest excavations ever carried out in a Scottish town and established the importance of the archaeology and origins of towns in Scotland as much to fellow archaeologists and planning authorities as to the general public. Both excavations demonstrated that archaeological levels did survive with a particularly good medieval pottery assemblage, but the momentum was somehow lost and, barring Thomas Robertson's excavation in 1974, nothing else was done in Dumbarton for nearly 25 years. Although there have been some major developments since the early 1970s, most notably the bypass, it has been the numerous small, piecemeal developments, particularly in the backlands between High

Street and the River Leven, that have potentially done the greatest damage, slowly eroding away what remains of the archaeology of this small, but important, medieval burgh and port. The introduction of NPPG 5 in 1994, the local publicity that the 1997 excavation generated and the publication of Historic Scotland's Scottish Burgh Survey of Dumbarton in 1999 have at last managed to engender renewed interest in the burgh's medieval past and stem the steady loss of archaeological information.

It was possible partially to compare and contrast the development of two adjacent burgh plots at 94–102 High Street, although this investigation was largely confined to the mid-backlands area. Both plots appear to have started life as typical backlands used for gardens, stockyards and pit-digging before being built up in the late medieval period. This may be due merely to population pressure, but, given the industrial nature of the buildings and finds, it may have been in response to economic opportunities such as those provided by numerous phases of building work at the castle or, perhaps, by the choice of Dumbarton as a shipbuilding and outfitting base for the royal fleet in the late 15th century and first half of the 16th.

The dating evidence seems to fit within this historical framework. In the mid-backlands at least, both plots appear to have been occupied by workshops established at roughly the same time, probably in the 15th century. The timber building in Plot 2 was replaced by two stone buildings. The building in Plot 1 may have started life as a timber structure before being replaced in stone along much the same lines. Quality buildings such as this, which appears more substantial than a mere ancillary outhouse or shed set back from the frontage, may suggest that the respective plots had already been subdivided by the end of the 15th century and that the middle backlands were now functioning as independent properties in their own right, rather than as service areas for frontage buildings.

The analysis of the charcoal, ash and slag from hearths and from clay floors immediately

around the hearths within the stone building (Plot 1, Phase 1 and 2) proved somewhat elusive as to what was being produced or what processes were involved (Photos-Jones, above). There was, however, some evidence for hammerscale and the vitreous charcoal, in particular, provoked some discussion as to whether this was rare evidence of coke production in the medieval period. There were too many hearths within this building to be purely domestic in function, but, if they were semi-industrial or craftwork orientated, exactly what they were producing or being used for has proved difficult to determine. The unexcavated timber building in Plot 2 may also have been a workshop. Of the 19 slag-bearing contexts, only five originated from within the building in Plot 1 (38, 121, 152, 168, 246). Similarly, it had been hoped that spatial analysis of the numerous small finds could also provide some clue as to the function of the building (Cox & Franklin, above), but of the 34 contexts producing iron objects, for example, only four were derived from within the building (69, 137, 168, 246). Two contexts (168, 246), a make-up layer for a floor and a rubble dump respectively, produced both slag-like material and iron objects.

However, studied as an assemblage, the iron ore, slag, possible furnace fragments and charcoal does indicate ironworking (Photos-Jones, pers comm). There was also a high proportion of nails within the finds assemblage and although it would be tempting to suggest that these were being manufactured for the construction or refitting of late medieval ships, or were a by-product of salvage, this material is scattered throughout all three phases and across both burgage plots, much of it from garden soils, pit fills and levelling dumps outside the buildings thought to be workshops.

It was not possible during the excavation to examine the earliest levels (which lie preserved beneath the new building), but test-pitting carried out during the initial site evaluation provided a glimpse of what lay unexcavated. The possible cesspit (Plot 2, Phase 1), which

contained a fig seed and Gritty ware pottery, offers both paleo-environmental potential for the future and suggests that early levels do survive. Whether they can provide supporting evidence that Dumbarton was developed on a 'greenfield site' in 1222 or has much earlier origins remains an avenue for future excavation. The possible burgage plot boundary ditches found at the College Street excavation, for example, would appear to support the former as they contained 13th century pottery contemporary with the founding of the burgh. Features of this early date this far north of High Street also provide some idea as to the extent of the medieval burgh.

The documentary sources for Dumbarton record the age-old problem of flooding and the numerous attempts to counteract it. Although no evidence of actual flooding was identified during the excavation, the deep cultivation horizons and thick levelling dumps recorded may also have served to raise the ground level above the floodwaters, incidentally sealing and preserving earlier levels. If these deposits really are a response to the problem of flooding then this site may prove typical of others and deep levelling dumps sealing early layers may be a recurring feature of the archaeology of Dumbarton.

The pottery recovered from late medieval and early post-medieval levels in Dumbarton has added to our knowledge of the ceramics of this later period and has provided the first known find spots in Scotland of both Donyatt Ware (Somerset) and Italian tin-glaze Polychrome. The assemblage, which complements those recovered from other west coast burghs such as Ayr, Paisley and Glasgow, indicates trading links and inland networks markedly different from those of the east-coast burghs; the former engaged in trade with France, Germany, Spain, Italy and the west coast of England, the latter with the Low Countries and northern England (Hall & Franklin, above). The French wine trade was undoubtedly of great importance to the medieval economy of Dumbarton and the other west coast burghs. The assemblage has

also provided further evidence to support a west coast production centre of that supposedly east coast medieval phenomenon, Gritty wares.

Working to a formation level, as at 94–102 High Street, represents a considerable saving to the developer of both time and money and is in keeping with the policies expressed in NPPG 5 of preservation in situ. From an archaeological perspective, however, the only way to fully understand the development of a medieval urban site, or perhaps any site, is to remove it completely and reconstruct it from the recorded data during post-excavation analyses. On the 94–102 High Street frontage, a virtually complete sequence of medieval deposits was preserved for future archaeologists to record and study if redevelopment threatens again. At the rear of the site, approximately half the surviving archaeological deposits were excavated, but the formation level coincided with the most complex stratigraphy, including a sequence of timber and stone buildings in two adjacent properties. These remain preserved beneath the new development, but only a detailed record of the new building's foundation design and careful demolition in years to come will ensure they survive to be studied once again.

ACKNOWLEDGEMENTS

SUAT would like to thank the developer, Highland Improvements Ltd, for providing the funding for the excavation, post-excavation and publication of the results of the work at 94–102 High Street, and their agent, Mr Hood, of Hood Graham Ltd. We would also like to thank Historic Scotland, and in particular Olwyn Owen, for their financial support and West of Scotland Archaeology Services (WOSAS), and in particular, Hugh McBrien, for their curatorial role in the 94–102 High Street excavation. Thanks are also due to Lawrence Keppie, Hunterian Museum, for tracing the finds and other archive material.

Derek Hall would like to thank Richard Coleman-Smith for identifying the Donyatt ware, George Haggarty for identifying the French wares and Alejandra Gutierrez for identifying the Iberian Coarsewares.

E Photos-Jones is indebted to Mr M McLeod for his invaluable assistance in the undertaking and characterization of the XRD spectra of the industrial soils.

Julie Franklin would like to thank George Haggarty for identifications, dating and ideas related to the pottery from Eric Talbot's excavations.

The late Thomas Robertson, in his Glasgow Archaeological Bulletin report, extended his thanks to Mr Eric Talbot for his invaluable help in organizing the excavation and to the members of the Glasgow University Archaeological Society who helped with the digging. The excavation of 101–3 High Street was carried out with the permission of F W Woolworth Ltd and that at 75 College Street with the permission of Dumbarton Town Council.

Frank Moran drew the artefact illustrations, and the plans were drawn by David Munro. Catherine Smith edited earlier versions of this paper.

Finally, the author would like to thank Eric Talbot for his help and assistance throughout the project and for allowing access to his own archive material.

NOTE

- 1 During the early part of 1974, a series of trial trenches was opened up under the direction of the late Thomas Robertson, prior to road widening in Riverside Lane, a street linking the High Street with the Shore, some 200 yards from the Old Parish Church (Robertson 1975). Although a small number of sherds of late-medieval pottery were recovered from two pits close to the street frontage, no stratification could be adduced. It was concluded that all remains of previous building had been stripped away during the construction of the tenements still standing on the site in 1974.

REFERENCES

- Anon nd *Plan of the Town and Castle of Dumbarton*. (Undated, but probably pre-1765, as it shows the ferry, which preceded Dumbarton Bridge opened in 1765.)
- Alcock, L & Alcock, E A 1990 'Reconnaissance excavations on Early Historic fortifications and other royal sites in Scotland, 1974–84: 4, Excavations at Alt Clut, Clyde Rock, Strathclyde, 1974–75', *Proc Soc Antiq Scot*, 120, 95–149.

- Cachart, R & Coleman, R 1997 'A site evaluation at 94–102 High Street, Dumbarton'. Unpubl report.
- Clarke, J 1997 'The Later Medieval Pottery', in Hill, P, *Whithorn and St Ninian: the excavation of a monastic town 1984–91*. Stroud.
- Coleman-Smith, R & Pearson, T 1988 *Excavations in the Donyatt Potteries*. Oxford.
- Cruden, S 1952 'Scottish Medieval Pottery: the Bothwell Castle Collection', *Proc Soc Antiq Scot*, 86 (1951–2), 140–70.
- Davey, P (ed) 1987 *The Archaeology of the Clay Tobacco Pipe, X: Scotland*. Oxford (=Brit Archaeol Rep, Brit Ser, 178).
- Dearne, M J & Branigan, K 1995 'The use of coal in Roman Britain', *Antiq J*, 75, 71–105.
- Dennison, E P & Coleman, R 1999 *Historic Dumbarton: the archaeological implications of development*. Edinburgh (=Scott Burgh Survey).
- Dixon, P J, Mackenzie, J R, Perry D R & Sharman P 2002 *The origins of the settlements at Kelso and Peebles, Scottish Borders*. Scottish Archaeological Internet Reports, <http://www.sair.org.uk/sair2/sair2.pdf>.
- Duco, D H 1981 'De Kleipijp in de Zeventiende Eeuwse Nederlanden', in Davey, P (ed) *The Archaeology of the Clay Tobacco Pipe, vol V part ii: Europe 2*, 111–367. Oxford (=Brit Archaeol Rep, Int Ser, 106.2).
- Dunning, G C 1968 'The trade in medieval pottery around the North Sea', *Rotterdam Papers*, 1, 35–68.
- Franklin, J & Hall, D W forthcoming 'The pottery', in Perry, D R et al, 'Excavations in Ayr 1983–87'.
- Good, G L & Tabraham, C J 1981 'Excavations at Threave Castle, Galloway, 1974–78', *Med Archaeol*, 25, 90–140.
- Haggarty, G 1980 'The pottery', in Ewart, G 'Excavations at Stirling Castle 1977–78'. *Post-Med Archaeol*, 14, 36–46.
- Haggarty, G 1984 'Observations on the ceramic material from phase I pits BY and AQ', in Tabraham, C, 'Excavations at Kelso Abbey', *Proc Soc Antiq Scot*, 114, 395–7.
- Haggarty, G & Will, R 1995 'Ceramic Material', in Lewis, J H & Ewart, G J, *Jedburgh Abbey: the archaeology and architecture of a Border abbey*, 98–105. Edinburgh (=Soc Antiq Scot Monogr Ser, 10).
- Hall, D W 1996a 'Blind date-Scottish medieval pottery industries', *Tayside Fife Archaeol J*, 2, 126–8.
- Hall, D W 1996b 'The pottery', in Bowler, D, Cox, A & Smith, C (eds) 'Four excavations in Perth 1980–1984', *Proc Soc Antiq Scot*, 125, 952–9.
- Hall, D W 1997 'The pottery', in Rains, M & Hall, D W (eds) *Excavations in St Andrews 1980–89: a decade of archaeology in a historic Scottish burgh*, 40–63. Glenrothes (=Tayside Fife Archaeol Comm Monogr, 1).
- Hall, D W & Crowdie, A 2002 'The pottery', in Dixon, P J, Mackenzie, J R, Perry D R & Sharman P.
- Haslem, J 1993 'Glass vessels', in Margeson, S, *Norwich Households: the medieval and post-medieval finds from Norwich survey excavations 1971–1978*, 97–117. Norwich (=East Anglian Archaeol Rep, 58).
- Higgins, D 1981 'Surrey clay tobacco pipes', in Davey, P (ed) *The Archaeology of the Clay Tobacco Pipe, vol VI: pipes and kilns in the London region*, 189–293. Oxford (=Brit Archaeol Rep, Brit Ser, 97).
- Hodgson, G W I 1983 'The animal remains from mediaeval sites within three burghs on the eastern Scottish seaboard', in Proudfoot, B (ed) *Site, Environment and Economy*, 3–32. Oxford (=Brit Archaeol Rep, Int Ser, 173).
- Houart, V 1977 *Buttons: a collector's guide*. London.
- Hurst, J G 1964 'Sixteenth and seventeenth century imported pottery from the Saintonge', in Evison, V I, Hodges, H & Hurst, J G (eds) *Medieval Pottery from Excavations*, 221–55. London.
- Hurst, J G, Neal, D S & van Beuningen, H J E 1986 *Rotterdam Papers VI: pottery produced and traded in north-west Europe 1350–1650*. Rotterdam.
- Jennings, S 1981 *Eighteen Centuries of Pottery from Norwich*. Norwich (=East Anglian Archaeol Rep, 13).
- Jennings, S 1992 *Medieval Pottery in the Yorkshire Museum*. York.
- Latham, R E 1968 *Bede A History of the English Church and People* trans Sherley-Price, L, revised Latham, R E. London.
- McCarthy, M R & Brooks, C M 1988 *Medieval Pottery in Britain AD 900–1600*. Leicester.
- Macdonald, A D S & Laing, L R 1975 'Excavations at Lochmaben Castle, Dumfriesshire', *Proc Soc Antiq Scot*, 106, 124–57.
- Medieval Pottery Research Group 1998 *Guide to the Classification of Ceramic Forms* (=Med Pot Res Gp Occ Pap, 1).

- Photos-Jones, E 1997 The Woodend 'Industrial Waste'. Unpubl report.
- Photos-Jones, E, Atkinson, J A, Hall, A J & Banks, I forthcoming 'The Bloomery Mounds of the Scottish Highlands: Part I, the archaeological background'.
- Robertson, T 1974 'Dumbarton', *Discovery Excav Scot* 1974, 80.
- Robertson, T 1975 'Dumbarton, Riverside Lane, 1974', *Glasgow Archaeol Soc Bulletin*, NS1, 1 (Autumn 1975).
- Simpson, G (ed) 1972 *Scotland's Medieval Burghs: an archaeological heritage in danger*. Glasgow.
- Smith, C 1998 'Dogs, cats and horses in the Scottish medieval town', *Proc Soc Antiq Scot*, 128, 859–85.
- Smith, C 2000 'A grumphie in the sty: an archaeological view of pigs in Scotland, from their earliest domestication to the agricultural revolution', *Proc Soc Antiq Scot*, 130, 705–24.
- Smith, C 2002 'The animal bone from Bridgegait, Peebles', in Dixon, P J, Mackenzie, J R, Perry, D R & Sharman P.
- Smith, C unpublished 'The animal bone from Site 17B, Glasgow Cathedral Square'. Unpubl report.
- Tabraham, C J 1984 'Excavations at Kelso Abbey', *Proc Soc Antiq Scot*, 114, 365–404.
- Talbot, E 1971 'Dumbarton', *Discovery Excav Scot* 1971, 19.
- Talbot, E 1972a 'Dumbarton', *Glasgow Archaeol Soc Bulletin*, 1:1 (Spring 1972), 4.
- Talbot, E 1972b 'Dumbarton', *Glasgow Archaeol Soc Bulletin*, 1:2 (Autumn 1972), 6.
- Talbot, E 1972c 'Archive report on recent archaeological work in Dumbarton'. Unpubl report in Dumbarton Library.
- Talbot, E 1973 'Dumbarton', *Discovery Excav Scot* 1973, 24.
- Titmus, J undated *Pottery from Dumbarton High Street and College Street*. Unpubl undergrad diss, Univ Glasgow.
- Turnbull, J 2001 *The Scottish Glass Industry 1610–1750*. Edinburgh (=Soc Antiq Scot Mongr, 18).
- Will R, Chenery, S, Haggarty, G, Hall, D W, Jones, R & Vince, A forthcoming 'Sourcing Scottish White Gritty ware'.
- Wood, J 1818 *Plan of the Town of Dumbarton*.

Cartographic sources

- Ordnance Survey, 1:500, 1866.
- Ordnance Survey, 1:500, 1898.
- Ross, C 1777 'Dumbarton Town', inset in *A Map of the Shire of Dumbarton taken from an actual survey*.
- Wood, J 1832 'Dumbarton', inset in 'Map of Dumbartonshire', in Thompson, J *The Atlas of Scotland*.

This report is published with the aid of grants from Highland Improvements Ltd and Historic Scotland.