

Archaeological Field Unit

**Prehistoric, Medieval and Post-Medieval Features  
on Land to the South of the High Street, Foxton**

Andrew Hatton

March 2004

**Cambridgeshire County Council**

Report No. 199

Commissioned by Moss Builders and Cambridgeshire County Council Property  
and Procurement Division

**Prehistoric, Medieval and Post-Medieval Features  
on Land to the South of the High Street, Foxton  
(TL 411 482)**

Andrew Hatton

March 2004

Editors: Mark Hinman and Elizabeth Shepherd Popescu

Illustrator: Jon Cane

with contributions by Ian Baxter, Corinne Duhig, Stephen Kemp, Chris Montague,  
Paul Sealey and Paul Sperry



Report No. 199

©Archaeological Field Unit  
Cambridgeshire County Council  
Fulbourn Community Centre  
Haggis Gap, Fulbourn  
Cambridgeshire CB1 5HD  
Tel (01223) 576201  
Fax (01223) 880946

Arch.Field.Unit@cambridgeshire.gov.uk  
<http://edweb.camcnty.gov.uk/afu>

## **SUMMARY**

*In response to a series of proposed developments including housing, a community centre and a school, eight stages of archaeological work were undertaken by the Archaeological Field Unit (AFU) of Cambridgeshire County Council between 1998 and 2002 in accordance with Briefs issued by the County Archaeology Office (CAO). This work included a desk-based assessment, evaluations and area excavation.*

*The earliest archaeologically significant remains present within the development area consisted of a general background scatter of struck flint identified largely in the upper fills of medieval ditches. The earliest cut features were of Late Iron Age date, and comprised a possible pyre and two small pits one of which contained cremated human remains in a Gallo-Belgic pot.*

*Evidence for Roman activity within the development area was restricted to occasional sherds of pottery, with no clear evidence of occupation.*

*The medieval period saw an increase in land usage, evidence for which took the form of large ditches which divided-up the landscape. Extensive pitting was also identified.*

*Progression from the medieval to the post-medieval periods saw a change in the method of land division with the construction of clunch walls. Further extensive pitting took place in this period, probably for the ad hoc recovery of gravel.*

*Since the 19th century the development area has been used as allotments and orchards, for light industry (bicycle manufacturing) and later housed the village hut and subsequent village hall.*

## TABLE OF CONTENTS

<b>1</b>	<b>INTRODUCTION</b>	<b>1</b>
<b>2</b>	<b>GEOLOGY AND TOPOGRAPHY</b>	<b>1</b>
<b>3</b>	<b>ARCHAEOLOGICAL AND HISTORICAL BACKGROUND</b>	<b>1</b>
<b>4</b>	<b>STRATEGY AND METHODOLOGY</b>	<b>5</b>
<b>5</b>	<b>RESULTS</b>	<b>7</b>
	<b>Period 1: Prehistoric</b>	7
	<b>Period 2: Late Iron Age/Roman</b>	9
	<b>Period 3: Roman</b>	9
	<b>Period 4: Medieval</b>	9
	<b>Period 5: Post-Medieval</b>	21
	<b>Period 6: Modern</b>	29
<b>6</b>	<b>DISCUSSION AND CONCLUSIONS</b>	<b>31</b>
	<b>ACKNOWLEDGEMENTS</b>	<b>34</b>
	<b>BIBLIOGRAPHY</b>	<b>35</b>
	<b>Maps Consulted</b>	<b>35</b>
	<b>APPENDICES</b>	
<b>Appendix 1</b>	Lithic Analysis, by Stephen Kemp	36
<b>Appendix 2</b>	Selected Iron Age and Roman Pottery, by Paul Sealey	37
<b>Appendix 3</b>	Medieval Pottery, by Paul Spoerry	38
<b>Appendix 4</b>	Small Finds and Metal Detector Survey, by Chris Montague	39
<b>Appendix 5</b>	Human Bone, by Corinne Duhig	40
<b>Appendix 6</b>	Animal Bone, by Ian Baxter	42
<b>Appendix 7</b>	Environmental Remains, by Val Fryer	44
<b>Appendix 8</b>	Section Drawings	48
<b>Appendix 9</b>	Context List	50
<b>Appendix 10</b>	Site Photographs and Open Day Newspaper Coverage of Foxton	57

## LIST OF FIGURES

<b>Figure 1</b>	Location of evaluation area and archaeological trenches	2
<b>Figure 2</b>	Historic maps showing the development area	4
<b>Figure 3</b>	Phase 2: Late Iron Age cremations and possible pyre	8
<b>Figure 4</b>	Phase 4: medieval boundaries and drainage ditches	10
<b>Figure 5</b>	Phase 5: medieval ditches and pitting	14
<b>Figure 6</b>	Detail of 2002 excavation, Area 4	22
<b>Figure 7</b>	Phase 6: post-medieval quarrying and walls	24
<b>Figure 8</b>	Detail plan and section of wall <b>500</b>	26
<b>Figure 9</b>	Phase 7: modern features	30
<b>Figure 10</b>	Phase plan showing projected alignments of medieval ditches and post-medieval walls	32

## LIST OF TABLES

<b>Table 1</b>	Worked flint by context	36
<b>Table 2</b>	Metalwork	39
<b>Table 3</b>	Human remains	41
<b>Table 4</b>	Animal bone by context	42
<b>Table 5</b>	Plant remains	46
<b>Table 6</b>	Samples from FOX HS 01	47

**Prehistoric, Medieval and Post-Medieval Features on Land to the South of  
High Street, Foxton  
(TL 411 482)**

**1 INTRODUCTION**

Between 1998 and 2002 the Archaeological Field Unit (AFU) of Cambridgeshire County Council undertook eight phases of excavation within a new development area to the south-east of the High Street, Foxton (Fig. 1). The works were carried out by the AFU in response to Briefs issued by the County Archaeology Office (CAO).

Archaeological fieldwork commenced in 1998, with investigation at the High Street Allotments, Foxton, to the south of the High Street. Evaluation and monitoring was undertaken on adjacent land, to the south of the recreation ground, before a new school and community centre were built. An archaeological watching brief was also carried out south of the High Street during 1999. Further stages of archaeological fieldwork took place during 2000 including the monitoring of the foundation trenches of the community centre. The final stage of fieldwork was undertaken in 2002, with the excavation of a parcel of land to the west of the parish church, immediately south of the High Street.

**2 GEOLOGY AND TOPOGRAPHY**

The site lies on Lower Chalk overlying Melbourn Rock and Totternhoe Stone, just south of an area of 1st and 2nd terrace gravels (BGS 1952).

From the High Street the land slopes gently in a southerly direction from 18.3m OD to 18m OD beyond the southern boundary of the development area. The valley of the Cam is two miles wide between Chapel Hill, Barrington and West Hill, Foxton (Widdowson 1973) and the tributaries of the Cam or Rhee are fed from the spring line on the chalk 'uplands'.

**3 ARCHAEOLOGICAL AND HISTORICAL BACKGROUND**

Foxton lies south of the River Cam, to the west of Hoffer Brook and to the east of Shepreth/Foxton Brook. The development land has, in recent years, been agricultural/horticultural and there is no documentary evidence for any building on the site. Allotment boundaries are marked on the 1830 Enclosure map (Fig. 2) and whilst the boundaries themselves have disappeared some are preserved in lines of trees on the 1887 OS map (Fig. 2).

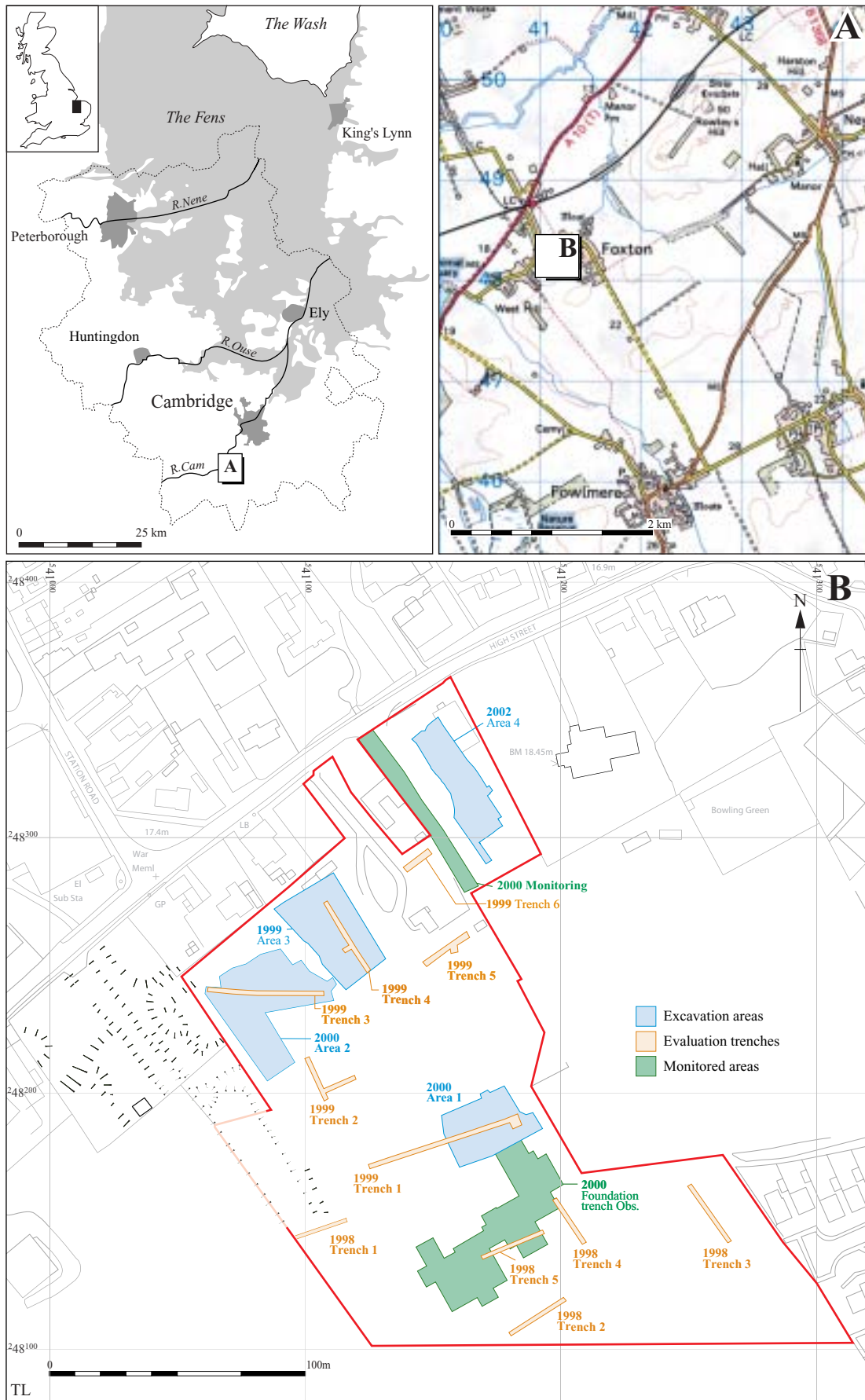

Based upon Ordnance Survey mapping with the permission of the Controller of Her Majesty's Stationery Office Crown Copyright. Unauthorised reproduction infringes Crown copyright and may lead to prosecution or civil proceedings. (Cambridgeshire County Council licence No. LA 07649X 2003)

**Figure 1** Location of excavation areas, trenches and observation areas with development area outlined.

Occupation of the river valleys in south-west Cambridgeshire is characterised in the Iron Age, Roman and medieval periods by settlements paired on either side of a ford (Taylor 1973). Foxton and Barrington are an example of this type of settlement pattern.

The presence of extensive crop marks, including those associated with substantial Iron Age and Roman rural settlement excavated in 1993, to the south and west of the present site (Macaulay 1995), suggests considerable prehistoric and early historic activity in the area.

Early Saxon cemeteries have also been found along the major river valleys in South Cambridgeshire (Malim & Hines 1998) and another Anglo-Saxon cemetery has been identified in the eastern part of the Cam valley at Foxton.

The name Foxton is first mentioned in the Domesday survey as *Foxetune* (EPNS 1973), interpreted as 'Farm where foxes abound'. The name appears to have changed by 1396 to Foxston and again by 1549 to Faxton. To the north of the development site is Bury Farm (Parker 1975), known in 1622 as Foxton Burye and Berry Close in 1840 suggesting a manorial site (burh).

The present village of Foxton was built along a brook, which is now filled in, and the former parish boundaries were the Cam or Rhee, Hoffer Brook, Shepreth Brook and the old Fowlmere Road. The open fields were enclosed following an Award made in 1830 (Wright 1982).

The site falls within the boundary of Herod's Farm and it has been noted that soil marks of small rectangles and a track along the south side of the village are the remains of medieval houses along what may have been a back lane running almost parallel to the High Street (Malim 1990). This suggests that the village has shrunk and that the former back lane was the southern boundary to a village green forming a settlement pattern similar to that seen at Barrington and Haslingfield. The aerial photographic assessment failed to identify earthworks or soil marks in the area of the proposed development. In pasture to the south of the High Street and west of the development site a pronounced hollow-way and several house platforms survive as upstanding features and were the subject of an earthwork survey carried out in 2000 (Fosberry 2000; see Fig. 1).

Archaeological recording was previously carried out 50m to the west and just over 100m to the north of the subject site (Kemp 1994). This work failed to reveal archaeological features, although the trenches were set over 10m back from the High Street and were less than 1m wide.

Less than 1km to the west a gas pipeline revealed a small quantity of Neolithic pottery and worked flint (Maynard *et al* 1994). Middle to Late Iron Age features were also recorded but the majority of features in this area appear to date to the 1st century AD with fewer 2nd and 3rd century features and an increase in activity in the 4th century including an inhumation cemetery which was in use between AD250-400. Limited evidence of 5th century occupation was found in this area.



1887 OS map



1830 Enclosure map



1810 OS map

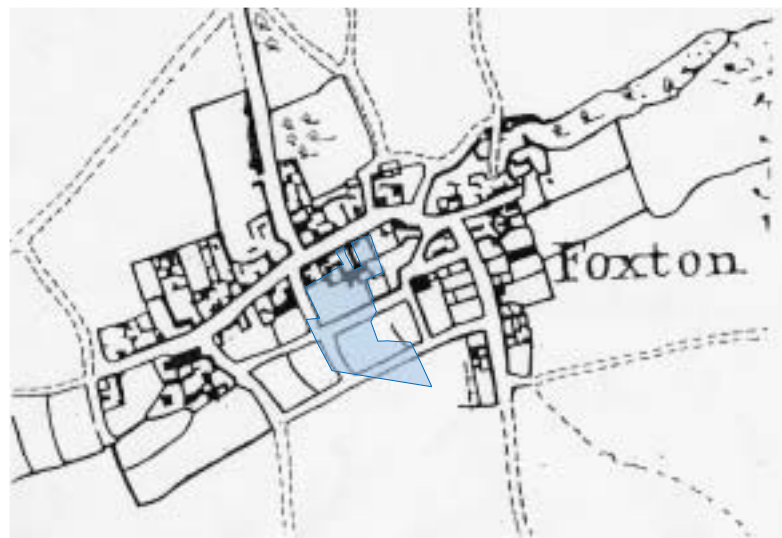

**Figure 2** Historic maps showing development area in blue tone.

Middle to late 19th-century cartographic evidence indicates the location of the parish hut (No 57 on the 1887 Ordnance Survey Map; see Fig. 2), the village pond south-east of the village hut and the High Street in its present location with property boundaries extending south towards the development site. The latter half of the 1920s saw the construction the village hall and associated ground works. The village pond was back-filled during the 1950s.

#### **4 STRATEGY AND METHODOLOGY**

Various responses were required to implement the archaeological conditions that had been placed on the development by the CAO. These responses included documentary research and a two per cent evaluation, the results of which led to four areas being defined as requiring excavation. In addition two other areas were subject to a watching brief but other construction works such as the access road were left unmonitored.

The original area identifiers used during each phase of excavation have been changed for clarity. These now consist of four excavation areas (Areas 1-4), eleven evaluation trenches (1998 Trenches 1-5; 1999 Trenches 1-6) and additional areas of archaeological monitoring.

Where excavation was required all soil in the designated areas above the archaeological horizon was removed with a mechanical excavator under archaeological supervision. Archaeological features were excavated by hand and features/deposits were recorded using the AFU's single context recording system. Each distinct cut, fill and layer was allocated an individual number. Within this report the cut/feature numbers are given in bold and the fill/deposit numbers are given in plain text. Contexts were numbered sequentially for individual phases of work (see Appendix 9). Where several sections were dug through ditches or in the case of the 2002 excavation a wall, a master number (M) has been assigned to the whole feature. Features were planned using a Total Station Theodolite and manual techniques.

Bulk samples from features were dry sieved through a 10mm mesh. Following consultation with the Cambridgeshire County Council Archaeology Development Control Officer a decision was taken not to take samples for flotation.

Metal detector surveys of the excavated areas and spoil heaps were carried out on three separate occasions by AFU staff and members of the Saffron Walden metal detectors club.

#### **4.1 Stage 1: Desk-Based Assessment**

An initial desktop survey considered cartographic, documentary, published and aerial photographic evidence. The only archaeological remains identified were traces of a lane leading south from the High Street. It has been suggested that a back lane might have extended from the extant hollow way to the west of the subject site east-west across the development area (Parker 1975) .

#### **4.2 Stage 2: Evaluation, FOX HS 98 (Fig. 1)**

Between 16th and 20th October 1998 an archaeological evaluation of the field to the south-west of the recreation ground identified two features cut into the chalk (Roberts 1998). The evaluation comprised five machine-excavated trenches (1998 Trenches 1-5) with a total length of 115.5 m, which gave a two per cent sample of the site. The north-eastern corner of the site had suffered a degree of disturbance during the 20th century and the north-western part of the site had been used as an orchard in the recent past. The rest of the site had been used for growing fodder beet and as allotments.

#### **4.3 Stage 3: Evaluation, FOX HS 99 (Fig. 1)**

Between 19th and 23rd April 1999, in the area just south of the High Street, four evaluation trenches (1999 Trenches 1-4) were excavated to a total length of 135m, which gave a two per cent sample of the site. In the north-eastern part of the site post-medieval activity had a significant impact on the underlying remains. A further evaluation trench was excavated along the line of the proposed access road, to the south-east of No. 42 High Street (1999 Trench 5).

#### **4.4 Stage 4: Watching Brief, FOX HS 99 (WB) (Fig. 1)**

In response to pressure from the client to begin construction on part of the site it was agreed in consultation with the CAO that rapid excavation of the area of the site most heavily affected by post-medieval disturbance could be undertaken at short notice. A watching brief in Area 3 (23rd to 29th April 1999), covering an area of 101sqm in the north-eastern part of the site, occurred immediately after the completion of the 1999 evaluation.

#### **4.5 Stage 5: Monitoring, FOX HS 00 (M) (Fig. 1)**

Monitoring of the foundation trenches of the community centre and new primary school between 1st May 2000 and 28th September 2000 was intended to investigate parts of the site not covered by earlier work in the area.

#### **4.6 Stage 6: Excavation, FOX HS 00 (Fig. 1)**

Between the 6th and 17th March 2000, an excavation commenced on Areas 1 and 2 covering 0.3ha (Roberts 2000). The parcel of land had been previously used as agricultural land, allotments or orchard. The excavation strategy was

designed to answer questions on the nature and character of the site, to identify prehistoric and Roman occupation features and provide dating evidence for those features identified in the 1999 evaluation.

#### **4.7 Stage 7: Monitoring, FOX HS 00 (M) (Fig. 1)**

Observations from monitoring of the service trench (gas and water pipes) took place to the east of No. 46 High Street in 2000. Tree roots had disturbed a considerable portion of the northern part of the trench. A modern (gas?) pipe crossed the trench, in a north-easterly to south-westerly direction, approximately 22m from the High Street. Another modern pipe crossed the trench at 48m from the High Street and just beyond this the topsoil and subsoil were approximately 0.4m deep over chalk natural.

Beyond this point only two features were visible cut into the chalk natural. The narrowness of the trench precluded identification of the features. Roots from trees and bushes to the west of the trench had penetrated to a depth of over 0.3m and had caused considerable disturbance to the topsoil and subsoil.

#### **4.8 Stage 8: Excavation, FOX HS 02 (Fig. 1)**

Between 8th and 26th April 2002 excavation commenced on land previously occupied by the village hall and associated car park, located south of the High Street and west of St Laurence's Church. Many of the features located in the northern half of the site had been heavily truncated. Excavation revealed that up to 0.50m of natural chalk had been removed prior to the deposition of clunch, lain as an aid to drainage, prior to the construction of the village hall.

## **5 RESULTS**

### **5.1 Period 1: Prehistoric**

#### *5.1.1 Phase 1: Bronze Age Activity?*

Although no features were definitely attributable to a specific early prehistoric period several features contained only flint tools or flakes, or no artefactual material. The leached nature of the fills suggests the possibility that these were deposited in an early period. The scatter of worked flints (12 in total; see Appendix 1) recovered suggested use of the area from as early as the Bronze Age, although there was no clear evidence of settlement or artefact concentrations.

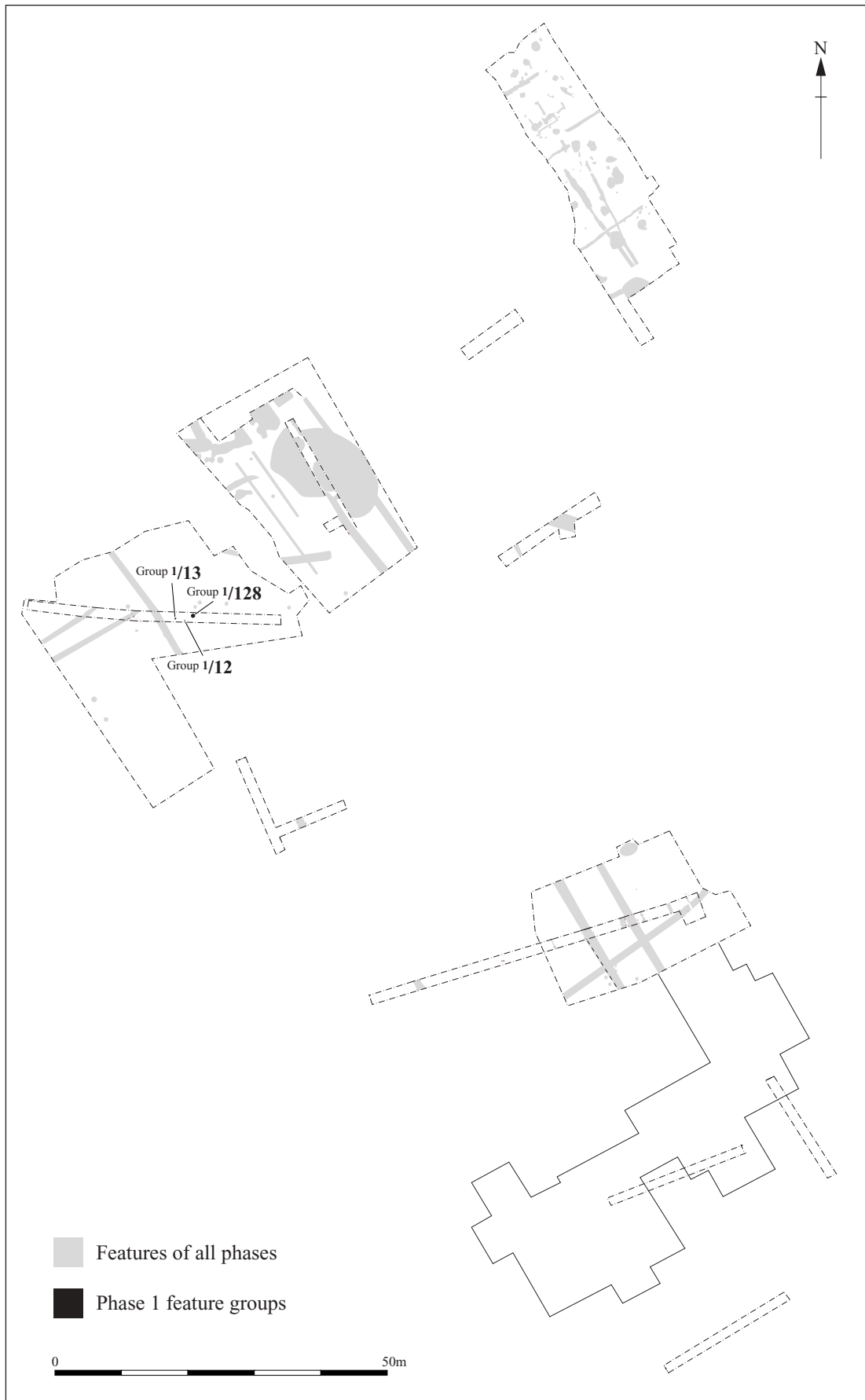

*Figure 3 Phase 2: Late Iron Age cremations and possible pyre*

### 5.1.2 *Phase 2: Late Iron Age/Roman*

#### a) Cremations (Fig. 3)

Late Iron Age activity was identified by cremated remains of a part of an individual in a vessel dated to the 1st century AD contained within a pit (**128**). A heavily truncated burnt area (**13**) and two cremation pits (**12** and **128**) were located at 53m, 57m and 62m respectively from the western end of Trench 3 (Group 1). Feature **13** was believed during the evaluation to be a cooking pit or hearth as its base had been discoloured due to direct heat. Later truncation had removed all traces of any former infilling. Its proximity to the cremation vessel found in pit **128** and burnt remains in pit **12** may indicate a link between the features, and may suggest that this was the base of a funeral pyre.

Pit **12** (0.4m long, 0.34m wide and 0.16m deep) was oval with moderately steep sides and a concave base. It contained a fill (55) of mid-pale grey brown silty sand with patches of dark brown staining from charcoal with occasional gravels and increasing amounts of charcoal towards the south. Two small sherds of late Iron Age/Roman pottery were found in this fill together with fragments of burnt bone.

Pit **128** (Appendix 10, Plate 4) (0.5m long, 0.45m wide and 0.11m deep) was irregular in shape with steep sides and a flat base. It contained a cremation vessel, identified as a butt-beaker dating to the 1st century AD (Appendix 2) and the cremated remains were those of a single adult of less than 35 years (Appendix 5) with two fragments of animal bone. Surrounding the around the cremation urn was a fill of light orange grey sandy silt (125).

## 5.2 **Period 2: Roman**

### 5.2.1 *Phase 3: Residual Roman Pottery*

A few Roman residual sherds were identified, including a fragment of samian pottery found in the upper fill of a medieval ditch (ditch **M3**; see below).

## 5.3 **Period 3: Medieval**

### 5.3.1 *Phase 4: Trackways, Boundary and Drainage Ditches*

Elements of the local medieval infield and outfield systems included two trackways. One of these trackways (**17** and **15**) ran parallel to the High Street and was aligned north-east to south-west: the other (**M1** and **M3**) was positioned at right-angles to the High Street, aligned north-west to south-east. Ditch **M4** was associated with the latter track on the basis of alignment, and may have functioned as a boundary/drainage ditch (Fig. 4). Two further possible drainage ditches (**M5** and **M6**) were identified 30m to the west of the parish church, each of which was aligned north-west to south-east.

#### a) North-East to South-West Aligned Trackway (Fig. 4)

Two parallel ditches **17** and **15** (equivalent to **257** and **266**; Group 2), approximately 2.5m apart and aligned north-east to south-west extended

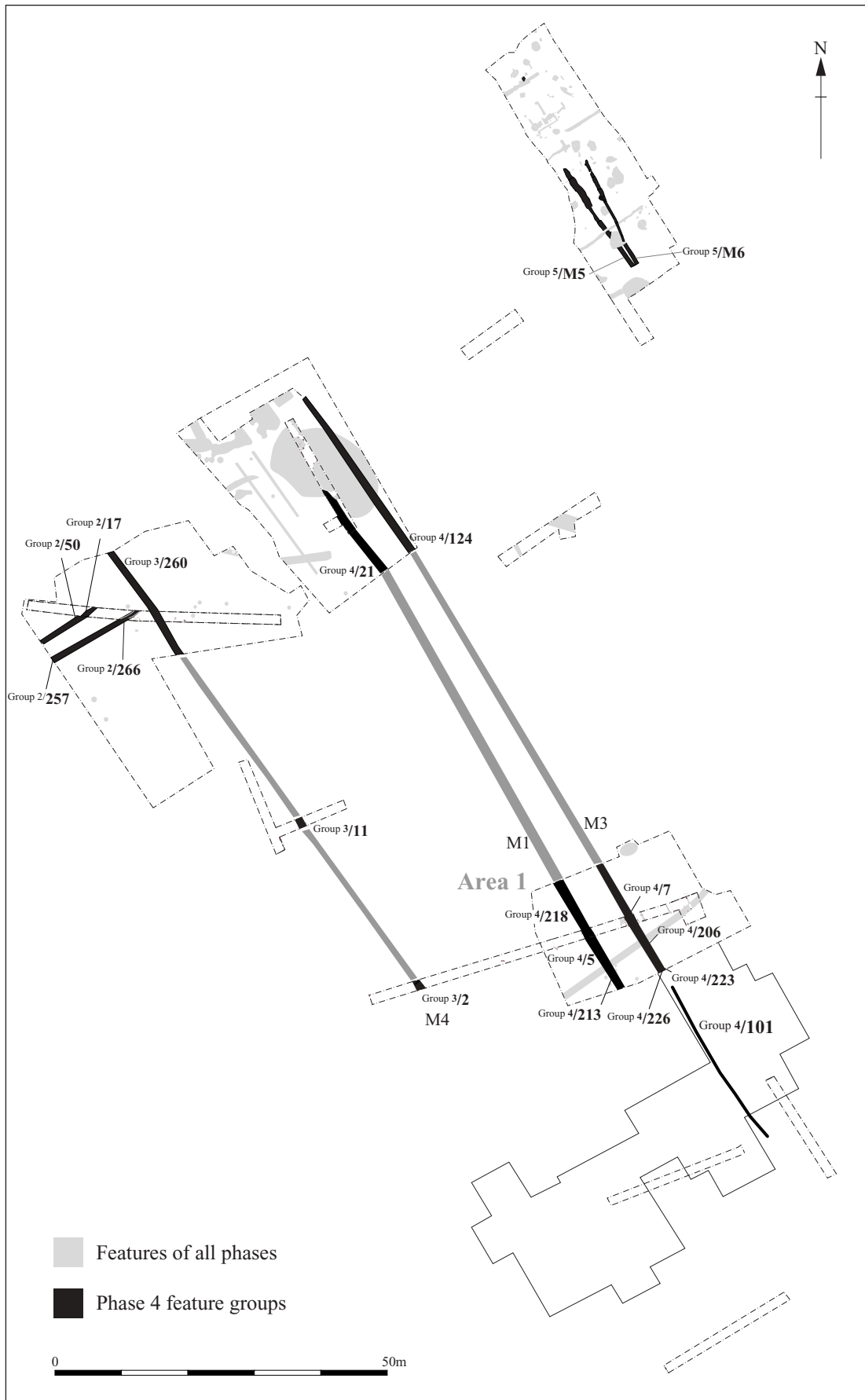

*Figure 5 Phase 4: Medieval boundaries and pitting*

beyond the south-western baulk of Area 2. These two ditches appeared to respect the position of ditch **M4**, which lay 2m to the north-east, but did not continue to the east of it.

Ditch **17=50**, (6m long) aligned north-east to south-west, contained a single fill (49), which contained sherds of medieval pottery and bone. Two further fills were recorded (51 and 52) one of which (52) contained a single sherd of medieval pottery.

Ditch **15=257-266** was aligned north-east to south-west and was 6m long.

Ditch segment **257** (1.3m wide and 0.55m deep) was aligned north-east to south-west. The primary fill (256) consisted of dark brown silty sand with moderate grit. Subsequent fills appeared to derive from the northern side of the ditch. Fill 255 was a reddish brown sand with moderate chalk fragments and grit sealed by dark brown silty sand with frequent grit and gravel (254). The final two fills (253 and 252) were fairly evenly distributed across the top of this ditch. Fill 253 was a dark brown silty sand with rare grit sealed by 252, a dark brown silty sand with more frequent grit. No finds were recovered from any of the fills in this part of the ditch. The eastern terminal of the ditch was excavated (cut **266**, fill 267) where it was 0.8m wide and 0.18m deep with more gently sloping sides and a flat base. The fill was a dark brown silty clay with occasional gravel.

Ditch section **266** (see section in Appendix 8) (0.80m wide and 0.18m deep) was aligned north-east to south-west. The fill (267) was greyish brown silty clay with occasional small stones.

b) Field Boundary (Fig. 4)

A single ditch (**M4**; Group 3), with an identified length of 100m, extended in a south-easterly direction across Area 2 and was also identified in 1999 Trenches 1 and 2. Three segments were excavated across the ditch (**2**, **11**, and **260**).

Ditch segment **260** (see section drawing in Appendix 8) (1.14m wide and 0.31m deep) was aligned north-west to south-east. Its fill (261) of greyish brown sandy silt with occasional small inclusions contained a single fragment of Roman tile.

Ditch segment **11** (1.28m wide and 0.30 deep) was aligned north-west to south-east. It contained two fills, the basal fill consisting of mid-grey sandy silt (42) with occasional small stone inclusions. Above this lay mid-orange grey sandy clay silt (41) with occasional small stone inclusions. Struck flint was recovered from fill 41.

Ditch segment **2** (1.30m wide and 0.27 deep) was aligned north-west to south-east. It contained three fills with the basal fill consisting of mid-grey sandy silt (32), with occasional small stone inclusions. Above this lay mid-grey sandy silt (31), with occasional small stone inclusions. Fill 31 was sealed by mid-orange grey sandy clay silt (30), with occasional small stones. No finds recovered from any of these fills.

c) North-West to South-East Aligned Trackway (Fig. 4)

Two parallel ditches (**M1** and **M3**; Group 4) aligned north-west to south-east extended in a south-easterly direction across Area 3 and were also identified in the foundation trenches of the community centre/school both within and to the south-east of Area 1. Both ditches were positioned at right-angles to the High Street. The internal space between the two ditches measured between 5 and 6m.



## Ditch M1

Ditch **M1** was located to the south-west of, and ran parallel to, ditch **M3**, and was noted in 1999 Trenches 1 and 4 and Area 1, with a visible length of 95m. Four segments (**21**, **218**, **5**, and **213**) were excavated across the ditch with segment **218** being located at the inter-section with a later ditch (**M2**). Segment **213** was positioned at a point where the ditch disappeared under the southern baulk.

Ditch segment **21** was aligned north-west to south-east and had steep sides and a flat base. Four sherds of medieval pottery were recovered from its fill (18).

Ditch segment **218** (see section drawing in Appendix 8) (0.80m wide, 0.51m deep) was aligned north-west to south-east and had steep sides and a flat base. Its basal fill consisted of grey clay (219) with no obvious inclusions. Above this lay a greyish brown silty clay (220) with occasional small stone inclusions.

Ditch segment **5** was aligned north-west to south-east and had steep sloping sides and a flat base. Its basal fill consisted of mid-orange grey sandy clay silt (33) with occasional small stone inclusions. Above this lay, light grey/white chalky clay silt (36) with occasional small stone inclusions.

Ditch segment **213** (2.15m wide, 0.40m deep) was aligned north-west to south-east and had shallow sides and a concave base. Its fill (213) was of light brownish grey clayey silt with occasional small stone inclusions.

## Ditch M3

Ditch **M3** was located to the north-east west of, and ran parallel to, ditch **M1** and was noted in Areas 1 and 3, and in the foundation trenches of the community centre with a visible length of 146m.

A total of five segments (**124**, **7**, **206**, **226**, **223**) were excavated across ditch **M3**. Segment **101** was truncated by the excavation of the foundation trenches of the community centre, which allowed for its recording. Segment **124**, located within Area 3 was excavated during the watching brief. A further segment (**7**) was excavated during evaluation. The three remaining segments were excavated during the excavation. Segment **206** was located at the inter-section of **M3** and late ditch **M2**, whereas segment **226** and **223** were both located at the southernmost baulk of Area 1.

Ditch **124** (1.30m wide, 0.20m deep) was aligned north-west to south-east and had steep sides and a flat base. It was filled with light orange brown sandy clay silt with moderate gravel inclusions (123).

Ditch **7** was aligned north-west to south-east and had steep sides and a flat base. It contained three fills with the basal fill consisting of light grey white chalky clay silt (39), with occasional gravel inclusions. Fill 37 was sealed by light grey white chalky clay silt (38) with occasional gravel inclusions. Fill 38, was in turn sealed by mid-orange grey sandy clay silt 37 with occasional gravel inclusions. Of the three fills identified within this ditch, only one (37) contained sherds of medieval pottery.

Ditch segment **206** (0.72m wide, 0.35m deep) was aligned north-west to south-east and had steep sides and a flat base. It contained two fills with the basal fill consisting of light grey clay (205) with occasional gravel inclusions. Above this lay, light greyish brown sandy clay (204) with occasional gravel inclusions.

Ditch segment **226** (1.3m wide, 0.68m deep) was aligned north-west to south-east and had steep sides and a flat base. Its basal fill consisted of light grey clay (225) with no large inclusions. Above this lay, light reddish brown sandy clay (224) with occasional gravel inclusions.

Ditch segment **223** (1.4m wide, 0.37m deep) was aligned north-west to south-east and had steep sides and an irregular base. Its basal fill consisted of light brownish grey clayey sand (222) with no large inclusions. Above this lay, light reddish brown sandy clay 221, with no large inclusions.

Ditch segment **101** (0.70m deep), aligned north-west to south-east, had steep sides and a concave base. Its fill (100) was of mid brown fine sand with occasional small flint inclusions which contained fragments of medieval pottery.

d) **Drainage Ditches (Figs. 4 and 6)**

Two ditches (**M5** and **M6**; Group 5), located in Area 4, were aligned north-west/south-east, and had visible lengths of 22m and 21m respectively. Both ditches were located on the south-western side of Area 4 approximately 25m from the north-western baulk. The two ditches appeared to be converging towards the south-eastern end of the site, although definite evidence of this had been removed during excavation of the village pond. The distance between the two ditches at the north-western end was 3.4m, steadily reducing to 0.20m to the south-east.

At 5m from the north-western terminal of ditch **M6**, the featured deepened for a distance of 4m before rising up to its original depth to continue towards the pond. The deeper stretch of ditchwork provided an aid to drainage in the form of a 'soak-away'.

**Ditch M5**

Two segments (**539**, and **542**) were excavated across ditch **M5**. Segment **539** was located at the north-western terminal of the ditch and segment **542** was located 15m to the south-east. Ditch segment **542** (see section drawing in Appendix 8) (0.44m wide, 0.36m deep) was aligned north-west to south-east. Its fill (543) was an olive brown clayey silt, with moderate small flint inclusions.

**Ditch M6**

Four segments (**525**, **523**, **546** and **527**) were excavated across ditch **M6**.

Ditch segment **525** (0.50m wide, 0.18m deep) was aligned north-west to south-east. Its fill (526) of brown clayey silt with occasional small flint contained sherds of pottery and fragments of animal bone.

Ditch segment **546** (0.60m wide, 0.19m deep) was aligned north-west/south-east. It was filled with yellowish brown clayey silt with occasional small flint inclusions (547).

Ditch **523** (4m long, 0.44m wide and 0.46m deep) was aligned north-west to south-east and had steep sides and a gradual base. Its fill of pale brown chalky silt with occasional large and small flint pebble inclusions (524), contained fragments of animal bone.

Ditch segment **527** (see section drawing in Appendix 8) (0.64m wide, 0.15m deep) was aligned north-west to south-east. Its fill consisted of greyish brown clayey silt with occasional small flint inclusions (528).

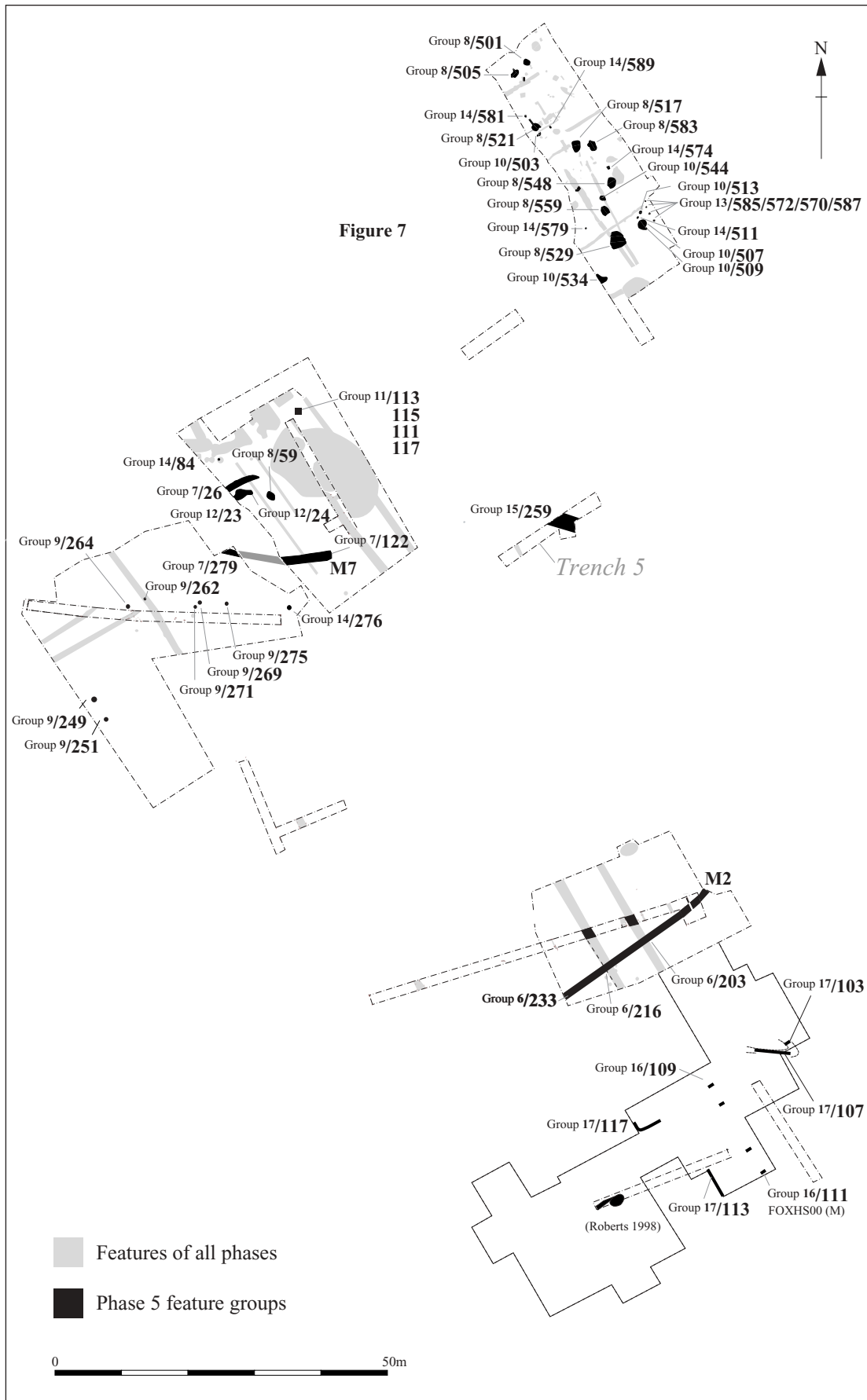

**Figure 5** Phase 5: Medieval ditches and pitting

### 5.3.2 Phase 5: Other Medieval Features

Investigation revealed evidence of large scale re-organisation of the medieval field system, a change in land usage and the introduction of small structures.

#### a) Boundary Ditch (Fig. 5)

A single ditch (**M2**; Group 6), with an identified length of 30m, extended in a south-westerly to north-easterly direction across Area 1. The terminal at the north-eastern end of the ditch had been truncated by modern disturbance.

Three segments (**203**, **216** and **233**) were excavated across the ditch. Segments **203** and **216** were located at the intersections with earlier ditches (**M3** and **M1** respectively). Segment **233** was located 6m from the south-western baulk of Area 1.

Ditch segment **203** (0.85m long, 0.57 wide and 0.29m deep) was aligned north-east to south-west. Its fill (202) consisted of light greyish brown clay silt with occasional flint inclusions..

Ditch segment **216** (see section drawing in Appendix 8) (1m long, 0.60 wide and 0.33m deep) was aligned north-east to south-west. Its fill (217) comprised light greyish brown clay silt with occasional flint inclusions.

Ditch segment **233** (see section drawing in Appendix 8) (0.95m long, 0.96 wide and 0.22m deep) was aligned north-east to south-west. Its fill (234) consisted of light greyish brown clay silt with occasional flint inclusions.

#### b) Curvilinear Ditch (Fig. 5)

A single curvilinear ditch (**M7**; Group 6) was identified 16m south-east of the north-western corner of Area 3 with a visible length of 6m, extending beyond the south-western baulk. The ditch did not reappear in Area 2 on the same alignment although a short section of ditch on the west-north-west to east-south-east alignment in Area 2, along with a second section of ditch on the east-west alignment in Area 3 have been interpreted as part of the same feature which thus defined an irregular C-shaped enclosure. The shape in plan of the ditch indicates it was enclosing a small area (220sqm) within an individual plot of land.

Three segments (**26**, **279** and **122**) were excavated across ditch **M7**, with the initial segment **26** located 2m from the south-western baulk. Segment **279** was located at the point where the ditch was exposed within Area 2 and segment **122** was placed at the eastern terminal of the ditch.

Ditch segment **26** (1.08m wide and 0.25m deep) had a steeply sloping northern edge and a more gently sloping southern edge and a flat base. Its fill (25) comprised light brown grey sandy clay silt with occasional gravel and contained fragments of animal bone but no datable material.

Ditch segment **279** (1.8m wide and 0.24m deep) had a gently sloping northern side, a steep, uneven southern side and a concave base. The fill (280) consisted of dark grey brown sandy silt with moderate gravel inclusions.

Ditch segment **122** (1.7m wide, 0.42m deep) was curvilinear in plan and had a gently sloping northern side, a steep, uneven southern side and a concave base. The basal fill consisted of light grey/white chalky clay silt (121), with occasional small flint inclusions. Above this lay, light brown clay silt (120) with occasional gravel inclusions, which contained fragments of animal bone.

c) Pitting (Figs. 5 and 6)

Nine large pits were identified during excavation in Area 4. Pits **501**, **505**, **521**, **517**, and **583** were located in the northern half of the site. Further south, pit **559** had been truncated during the modern period (Group 8). Pits **529** (same as **531**) and **548** located in the southern half of the site, do not appear to have been truncated by modern intervention and may have retained much of their original depth. A further pit (**59**) was identified in Area 3.

Environmental evidence from the fill of pit 521 (see Appendix 7) indicates the low density disposal of domestic/dietary waste.

Pit **501** (2m long, 2.10m wide, 0.09m deep) was sub-circular with shallow sides and a flat base. Its fill (502) was dark brown clayey silt with occasional flint inclusions from which fragments of medieval pottery were recovered.

Pit **505** (1.87 long, 0.80m wide, 0.07m deep) was an irregular oval in plan with shallow sides and irregular base. The fill (506) was grey sandy silt, with occasional flint inclusions. Fragments of tile were recovered.

Pit **517** (2.27m long, 1.44m wide, 0.45m deep) was an irregular oval in plan with steep sides and flat base. It contained three fills with the primary fill (518) consisting of pale brown silty sandy clay with moderate flint and chalk inclusions. Above this lay brownish yellow sandy silt (519) with frequent gravel and occasional flint inclusions. Sealing fill 519 was brown sandy silt with occasional flint inclusions (520). Each of these fills contained sherds of medieval pottery and fragments of animal bone.

Pit **521** (1.32m long, 1.40m wide, 0.22m deep) was sub-circular with shallow sides and a flat base. The fill (522) was light grey sandy silt, with moderate flint inclusions, which contained fragments of animal bone.

Pit **529** (same as 531) (see section drawing in Appendix 8) (1.50m long, 0.80m wide, 0.44m deep) was circular with steep sides and a concave base. Its fill (530) was pale brown sandy silt with frequent gravel inclusions.

Pit **531** (same as 529) (see section drawing in Appendix 8) (2.26m long, 2m wide, 0.46m deep) was sub-rectangular with steep sides and a concave base. The basal fill consisted of brown sandy silt (532) with frequent gravel inclusions. Above this lay yellowish brown silty sand (533) with frequent gravel inclusions.

Pit **548** (see section drawing in Appendix 8 and Appendix 10, Plate 5) was 2m long, 1.96m wide, 0.89m deep and had square steep sides, flat base. It contained six fills. The primary fill (549) was an olive yellow sandy silt with frequent pea-grit and flint inclusions. This deposit lined the edges of the feature and may represent dumping or slumping. Above this lay two fills (550; an olive brown sandy silt with occasional flint inclusions and 552; white chalk), which were recognisable as tip lines indicating deposition from the south-west side. Occupying the central area at the base of the pit was light olive brown sandy silt with occasional flint inclusions (551). Fill 553, olive brown clayey silt with moderate flint inclusions, occupied most of the rest of the pit. The final deposit brick rubble (554) was located towards the north-eastern side of the feature. This may have been the result of modern infilling as a means of creating a stable surface prior to the construction of a car park.

Pit **559** (see section drawing in Appendix 8 and Appendix 10, Plate 3) was 1.50m long, 1.88m wide, 0.80m deep. It was oval in plan with steep sides and flat base. The basal fill (557), which was sampled (Appendix 7) consisted of olive brown clayey silt with occasional large and small flint inclusions. Above this lay a deposit of white chalk (558) which had been truncated by modern machining and which contained occasional small and large flint inclusions. This appears to have acted as a capping layer.

Pit **583** (1.80m long, 1.40m wide, 0.25m deep) was complex in shape, with moderate sides and a flat base. Its fill (584) was a dark olive brown sandy silt with occasional small flint inclusions.

Pit **59** contained a single fill (58) of grey brown silty sand from which animal bone and eight small and abraded sherds of medieval pottery were recovered.

d) **Miscellaneous Pits (Area 2) (Fig. 5)**

Seven pits were identified in Area 2 (Group 9). Pits **249** and **251** were located in the south-western half of the area and pits **262**, **264**, **269**, **271** and **275** lay to the north-east.

Pit **249** (0.65m long, 0.6m wide and 0.21m deep) was oriented approximately north-west to south-east and had concave sides in the upper part, becoming steeper towards the sloping flat base. The basal fill (248) was a loose dark brown silty sand and the upper fill was a dark brown silty sand with moderate gravel and grit.

Pit **251** (1.10m long, 1.04m wide and 0.25m deep) was oriented approximately north-west to south-east and had steep sides and an irregular base. Its fill (250) was a dark brown silty sand with moderate grit.

Pit **262** (see section drawing in Appendix 8) (diameter 0.35m, 0.13m deep) had gradually sloping sides with a concave base. Its fill (263) was a brownish yellow silty sand with occasional small stones.

Pit **264** (see section drawing in Appendix 8) (diameter 0.79m, 0.19m deep) had a steep western side, a more gradually sloping eastern side and a concave base. Its fill (265) was a dark brown silty clay with small stones.

Pit **269** (diameter 1.5m and 0.2m deep) had concave sides and a shallow concave base. Its fill (268) was a dark greyish brown clay silt and contained the semi-articulated remains of a calf: to the south of pit **269** was a further very shallow pit, which contained articulated ribs, from the same animal.

Pit **271** (0.9m long, 0.63m wide, 0.28m deep) had steeply sloping concave sides and a concave base. Its fill (270) was a grey brown silty sand with moderate grit and chalk flecks.

Pit **275** (1.7m long, 1.6m wide and 0.23m deep) had gently sloping sides and a slightly uneven flat base. Its fill (274) was a mid brown slightly clay silt with moderate gravel which contained medieval and post-medieval pottery and animal bone.

A further feature (**278**) in this area was excavated but was found to be a tree hollow.

e) **Miscellaneous Pits (Area 4) (Fig. 5 and 6)**

Six pits were identified in Area 4: **503**, **544**, **513**, **507**, **509** and **534** (Group 10).

Pit **503** (0.84 long, 0.66m wide, 0.08m deep) was sub-rectangular with shallow sides and irregular base. Its fill (504) was a grey sandy silt, with occasional flint inclusions which contained no artefact material. The pit was truncated by a modern pipe trench.

Pit **544** (0.47m wide, 0.12m deep) was circular with shallow sides and concave base. Its fill (545) was light olive brown clayey silt with occasional small flint inclusions.

Pit **513** (0.60m diameter, 0.66m wide, 0.19m deep) was circular with moderate sides and a concave base. Its fill (514) was a light olive brown sandy silt with frequent small flint inclusions that contained sherds of medieval pottery.

Pit **507** (1.98 long, 1.75m wide, 0.54m deep) was sub-rectangular with steep sides and concave base. Its fill (508) was a grey brown sandy silt, with occasional flint inclusions.

Pit **509** (0.90 long, 0.70m wide, 0.18m deep) was sub-circular with steep sides and a concave base. Its fill (510) was a pale yellow sandy silt with moderate small flint inclusions that contained sherds of medieval pottery.

Pit **534** (3.7m wide, 0.22m deep) was oval with shallow sides and flat sloping base. Its fill (535) was a yellowish brown clayey silt with occasional large and small flint inclusions.

f) Possible Structure (Fig. 5)

A sub-rectangular pit **111** (Group 11) was identified towards the northern corner of Area 3. Three associated postholes were interpreted as being structural. Each of the postholes was evenly spaced around the north-eastern edge of the sub-rectangular pit perhaps forming a screen or temporary shelter.

The even distribution of the postholes around the edge of the larger sub-rectangular pit indicate a structural function, with the smaller posthole housing an upright, which functioned as an additional wall support for the other load-bearing uprights. The reason for the absence of evidence for a wall construction on the south-western side of the sub-rectangular pit may be due to the need for protection from the north-easterly prevailing wind. It is not possible to determine the type and function of this possible structure due to extensive damage caused by modern disturbance.

Pit **111** (1.9m wide and 0.08m deep) had steep sides and a flat base. Its fill (110) was a mid-light orange brown sandy clay silt with occasional gravel.

Posthole **113** (1.2m long, 0.7m wide and 0.3m deep) in the northern part of pit **111** was sub-rectangular with near vertical sides and an irregular base. Its fill (112) was a light to mid grey brown sandy clay silt with occasional chalk fragments at the northern end. There was heavy root disturbance in this feature.

Posthole **115** (diameter 0.32m, depth 0.16m) had steep sides and a concave base. Its fill (114) consisted of light to mid grey brown sandy clay silt with occasional chalk fragments.

Posthole **117** (diameter 0.6m, depth 0.4m, extending beyond the excavated area) was on the eastern edge of feature **111** but it could not be determined whether it cut the pit or fill of **111** and it is thus assumed to be contemporary. This posthole had vertical sides and a flat base. Its fill (116) was a light to mid-grey brown sandy clay silt with occasional chalk fragments. Two medieval base sherds (Essex micaeous ware grey ware; 1200-1400) were recovered from the deposit.

g) Drainage Ditch and Sump (Fig. 5)

Located 25m to the south-east of the north-western corner of Area 3 was a probable drainage ditch (**24**; Group 12) which had an identified length of 2.4m with the remainder obscured under the south-western baulk. An adjacent pit (**23**) may have served as a sump.

Pit **23** (1.7m wide and 0.65m deep) had steeply sloping sides and a flat base. Its fill (22) was a light brownish-grey sandy clay silt with occasional gravel inclusions that contained sherds of medieval pottery and fragments of animal bone.

Ditch **24** (0.8m wide and 0.2m deep) was aligned east to west. Its fill (22) was a light brownish-grey sandy clay silt with occasional gravel inclusions that contained sherds of medieval pottery and fragments of animal bone.

h) Fence-line/Boundary Marker (Fig. 5 and 6)

Four undated postholes (**585**, **572**, **570** and **587**; Group 13) were located in the south-eastern half of Area 4. Although the postholes contained no dating evidence they may represent the remnants of a fence-line. Their alignment reflects the churchyard boundary immediately to the east of the site.

Posthole **585** (0.35m wide, 0.05m deep) was circular with moderate sides and a concave base. Its fill (586) was mid-greyish brown silty sand with moderate small flint inclusions.

Posthole **572** (0.28m wide, 0.36m deep) was circular, with steep sides and a flat base. Its fill (573) was a dark greyish brown clayey silt with occasional small flint inclusions.

Posthole **570** (0.39m wide, 0.52m deep) was circular, with steep sides and a flat base. Its fill (571) was a dark greyish brown clayey silt with occasional small flint inclusions.

Posthole **587** (0.35m wide, 0.05m deep) was circular with moderate sides and a concave base. Its fill (588) was a mid-greyish brown silty sand with moderate small flint inclusions.

i) Miscellaneous Postholes (Fig. 5 and 6)

Seven undated postholes were located (Group 14) consisting of five in Area 1 (**581**, **589**, **574**, **579**, **511**); one in Area 3 (**84**) and another in Area 2 (**276**). A sample taken from posthole **579** indicated the possible disposal of domestic waste (Appendix 7).

Posthole **581** (0.24m wide, 0.10m deep) was circular with steep sides and a flat base. Its fill (582) was a greyish brown clayey silt with occasional small flint inclusions..

Posthole **589** (0.25m wide, 0.08m deep) was circular with steep sides and a flat base. Its fill (590) was a greyish brown clayey silt with occasional small flint inclusions..

Posthole **574** (0.42m wide, 0.18m deep) was rectangular, with steep sides and a flat base. it contained two fills with the basal fill consisting of white redeposited chalk (575) with occasional flint inclusions, which performed the function of posthole packing. A post pipe identified in section was filled with olive brown clayey silt (576) which contained <2% small flint inclusions.

Posthole **579** (0.27m wide, 0.11m deep) was circular with steep sides and a flat base. Its fill (580) was a dark grey clayey silt with occasional small flint inclusions.



Posthole **511** (0.40m wide, 0.42m diameter, 0.19m deep) was circular and steep sided, with a concave base. Its fill (512) was a light yellowish brown with moderate small flint inclusions.

Posthole **84** (0.28m diameter, 0.22m wide and 0.14m deep) had steep sides and a flat base. Its fill (92) was a pale grey/orange brown silty sand with very occasional gravels.

Posthole **276** (0.35m wide and 0.11m deep) had moderate sides and a concave base. Its fill (277) was a yellowish brown sandy silt with occasional small stones.

j) Ditch (Fig. 5)

A single large ditch (**259/291**; Group 15) was located centrally within 1999 Trench 5 and aligned east-west. Interpretation of its function of the ditch is problematic given its location solely within one trench. Given its size, however, it may have functioned as a boundary marker.

Ditch **259** (see section in Appendix 8) (3m wide and 0.8m deep) had steep sides and a slightly concave base. It appeared to have two re-cuts. The earliest phase of the ditch contained three fills: fill 285 was a brown clay sand, 284 a brownish grey silty clay and 283 a greyish brown clay silt. The fills of the first re-cut were 273 which was a brownish grey clay sand, 272 a light grey clay and 258 a brownish grey silty clay. The final re-cut (**291**) contained two fills: 282 which was a brown silty sand and 281 a brown silty sand.

k) Miscellaneous Ditches (Fig. 5)

Two undated ditches (**109** and **111**; Group 16) were located within foundation trenches within the footprint of the community centre/school to the south of Area 1. The form and fills contained within these two ditches were very different. Their common alignments, however, may suggest that they were contemporary. A gap between the two ditches suggests an entrance way.

Ditch **109** (3.70m wide and 0.75m deep) was aligned north-west to south-east and had vertical sides and a flat base. Its fill (108) was a dark brown silt with occasional small flint inclusions.

Ditch **111** (1.50m wide and 0.25m deep) was aligned north-west to south-east and had steep sides and a concave base. Its fill (110) was a light brown fine sand.

l) Miscellaneous Pits (Fig. 5)

Four undated pits of possible medieval date (**103**, **107**, **113** and **117**; Group 17) were located within the footprint of the community centre/school. The rather elongated shape of the features within this group is attributed to the fact that they were observed within narrow foundation trenches.

Pit **103** (0.50m long, 0.80m wide and 0.30m deep) was oval in plan with steep sides and concave base. Its fill (102) was of dark brown fine sand with occasional small flint inclusions.

Pit **107** (1.5m wide and 0.50m deep) was elongated in plan with steep sides and a concave base. Its fill (106) was mid brown fine sand with occasional small flint inclusions.

Pit **117** (1.5m wide and 1.1m deep) was elongated in plan with steep sides and a concave base. Its fill (116) was mid brown fine sand with occasional small flint inclusions.

Pit **113** (2.5m wide and 0.40m deep) was elongated in plan with steep sides and flat base. Its fill (112) was dark brown fine sand with occasional small flint inclusions.

## **5.4 Period 4: Post-Medieval**

### *5.4.1 Phase 6: Quarrying Activity, Wall Building and Drainage Ditches*

#### a) Localised Domestic Quarrying (Fig. 7)

Numerous quarries of probable post-medieval date were located (Group 18). Although many of the features were found to be inter-cutting they have been placed together as they may have functioned within a limited period. Few contained diagnostic finds. The location of the features, to the rear of structures situated along the street frontage suggests very localised *ad hoc* quarrying activity. The limited depth of excavation indicates that the purpose of digging was to recover moderate amounts of gravel for domestic use.

Pit **29** (1.3m long, 1.05m wide) extended beyond the northern edge of Area 3. Its fill (106) was of olive grey brown silty sand with occasional gravel.

Pit **65** (0.85m long, 0.75m wide and 0.25m deep) had near vertical sides and a flat base. The fill (75) contained fragments of post-medieval tile.

Pit **73** (over 6m wide) was not fully excavated but contained at least two fills. The lower fill (72) was a very light grey chalky clay silt with occasional flint nodules. The upper fill (71) was a light orange brown sandy silt with occasional gravel that contained sherds of post-medieval pottery.

Ditch **77** (over 3m long, 1.35m wide and 0.15m deep), oriented approximately north–south, had a moderately sloping eastern side and a gentle slope on the western side and a concave base. Its fill (87) was a very mottled pale grey-brown sandy and silty sand with occasional gravel.

Pit **78** (over 4m long, 2.6m wide and 0.33m deep) was sub-rectangular with a steep southern side and more gently sloping eastern and northern sides. The break of slope was concave and the base flat. The single fill (88) was a pale orange brown very faintly silty sand with occasional gravel.

Pit **79** (1.9m long, 1.6m wide and 0.37m deep) was sub-circular with moderately steep edges and a flat base. The fill (85) was a mid-pale grey brown slightly silty clay sand with occasional gravel. Medieval pottery was recovered from this feature, which was probably introduced during the large amount of modern disturbance that had taken place.

Pit **80** (1.3m long, 0.5m wide and 0.27m deep) was sub-rectangular with steep sides and a flat base. Its fill (89) was a mid-pale grey brown faintly silty sand with occasional gravel.

Pit **81** (0.95m long, 0.55m wide and 0.2m deep) had moderately steep sides and a concave base. Its fill (90) was a pale grey brown faintly silty sand with occasional gravel.

Pit **82** (0.9m long, 0.7m wide and 0.14m deep) had gently sloping sides and a gently concave base. The fill (86) was a pale grey brown silty sand with very occasional gravel and contained a small sherd of medieval pottery, which was probably introduced by modern disturbance.

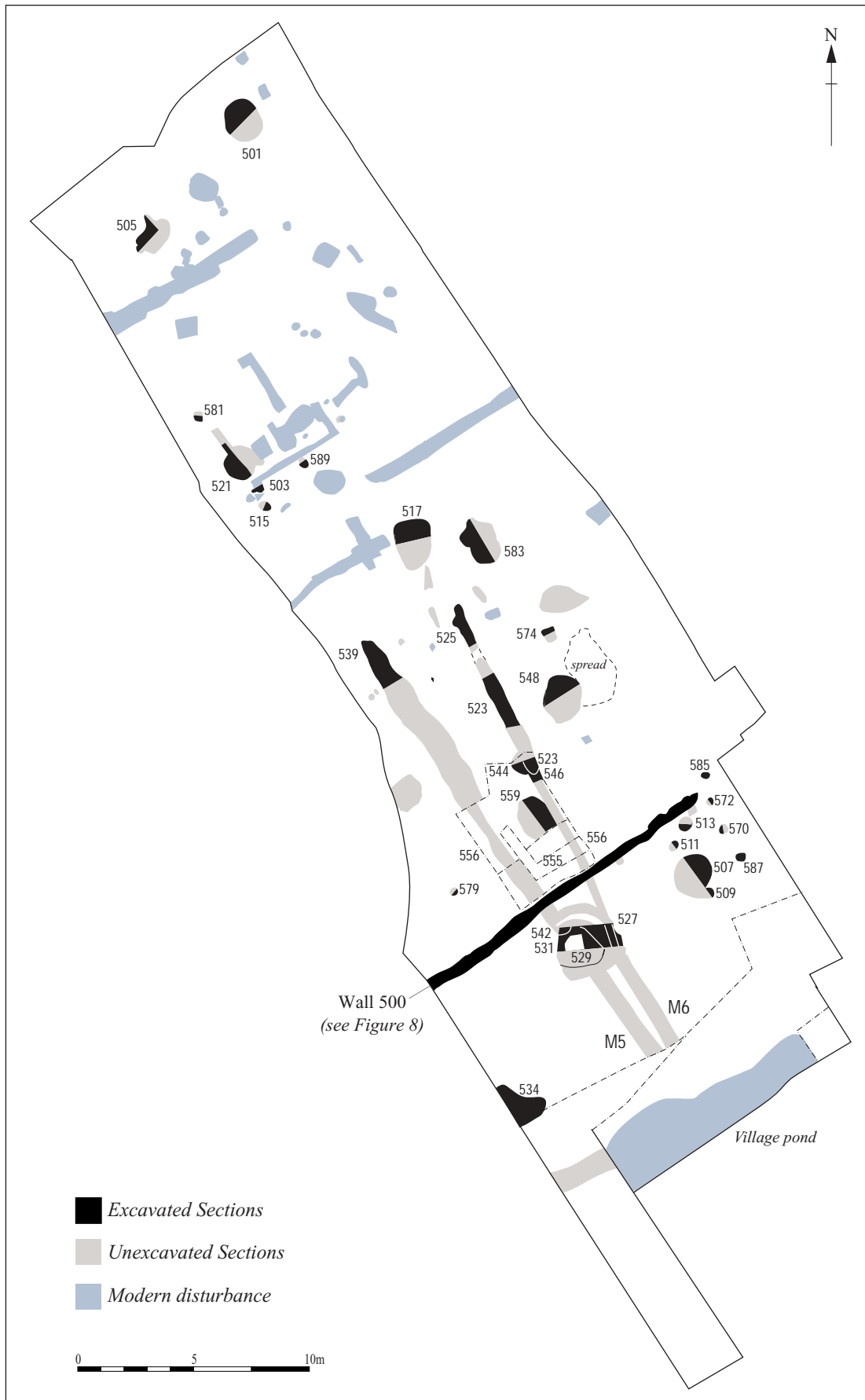

**Figure 6** Detail of 2002 excavation, Area 4

Pit **83** (0.9m long, 0.8m wide and 0.13m deep) was an irregular linear with uneven sides and a concave base. The fill (91) was a pale greyish brown silty sand with occasional small flint inclusions.

Pit **94** (3m long, 3.5m wide and 0.28m deep) was sub-rectangular with steep edges, a concave break of slope and a flat base. Its fill (101) was a pale-mid grey-brown faintly clay, slightly silty sand with occasional gravel. This feature contained a single sherd of glazed post-medieval pottery.

Pit **95** (0.6m long, 0.5m wide and 0.19m deep) had a steep south-eastern edge and a gently sloping western side and the base was flat. Its fill (108) was a pale-mid grey brown slightly silty sand with very occasional gravel.

Pit **96** (2.7m long, 2.25m wide and 0.53m deep) was sub-circular with a steep, stepped, eastern edge and a moderate western edge with a flat base. Its fill (102) was a mid-pale grey brown sandy silt with occasional gravel.

Pit **97** (1.2m long, 0.85m wide and 0.14m deep) was an irregular oval shape in plan with a steep western edge, and concave base. Its fill (103) was a mid-grey brown silty sand with occasional gravel which contained fragments of post-medieval tile and pottery sherds.

Pit **98** (1.5m long, 0.9m wide and 0.16m deep) was an irregular oval shape in plan with gently sloping sides and a concave base. Its fill (104) was a pale greyish pink compacted chalk with occasional flints.

Pit **107** (unexcavated) was circular in plan with a width of 0.28m.

Pit **109** (2m long, 0.80m wide and 0.20m deep) was linear in plan with gently sloping uneven sides and a concave base. Its fill (105) was a mid-grey brown silty sand with patches of moderate to frequent gravel and sand.

Pit **119** (3.3m wide, 0.27m deep) had vertical sides and a flat base. Fill 118 was a pale mid grey brown slightly clay silty sand with occasional gravel.

Pit **287** (see section drawing in Appendix 8) (0.87m long, 0.82m wide and 0.21m deep) had moderate sides and a concave base. Its fill (286) was a light grey brown silty clay with occasional gravel.

Pit **240** (see section drawing in Appendix 8) (1.7m long, 1.6m wide and 0.18m deep) had steep concave sides and a flat base. Its fill (239) was a dark grey brown clay silt which contained a worked flint flake and fragments of animal bone.

Pit **244** (see section drawing in Appendix 8) (diameter 4m, depth 0.5m) had slightly stepped edges and a fairly flat base and contained three fills. The primary fill (243) was a very pale brown clay silt, which was sealed by a grey brown clay silt (242). The upper fill of this feature, 241 was a pale brown clay silt. There was no artefact material from this feature.

Pit **230** (diameter 0.45m, depth 0.05m) had shallow, concave sides and a flat base. Its fill (229) was a very pale brown clay silt which contained a single piece of worked flint.

Pit **232** (diameter 0.3m, depth 0.12m) was circular with steep sides and a concave base. Its fill (231) was a pale grey soft clay silt.

Pit **236** (0.71m long, 0.3m wide and 0.09m deep) was shallow sided with a concave base, truncates 237. Its fill (235) was a light grey brown sandy clay.

Pit **238** (0.5m long, 0.4m wide and 0.03m deep) had gradually sloping sides and a concave base. Its fill (237) was a light brown mottled grey sandy clay.

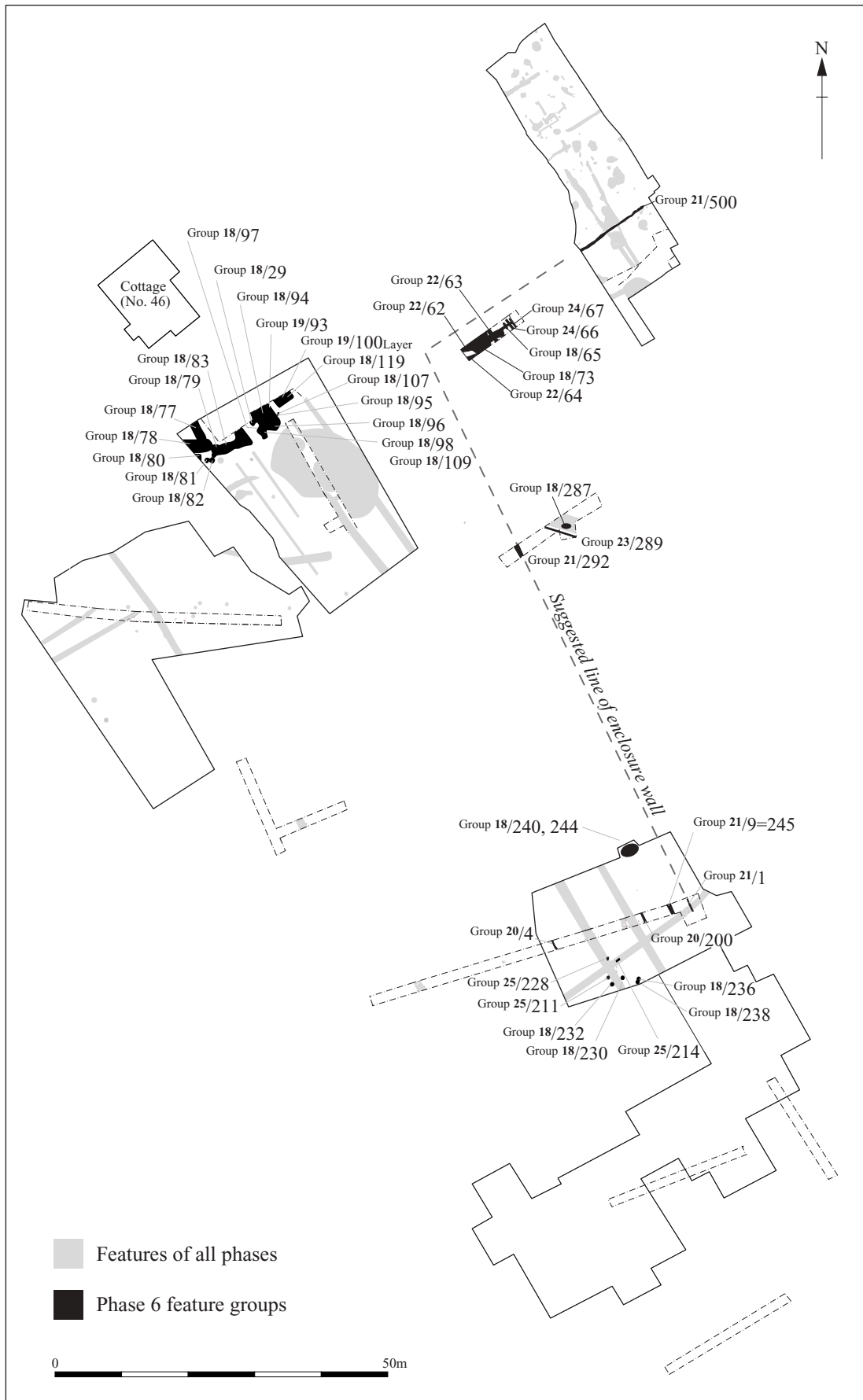

**Figure 7** Phase 6: Post-Medieval quarrying and wall construction

b) Wheel-Rut and Road-Metalling (Fig. 7)

A single wheel rut (**93**) and the remnants of a metalled surface (100) were identified in Area 3; Group 19). These features were undated but may have been contemporary with the quarrying activity detailed above: two of the quarry pits (**94** and **95**) cut into the wheel rut.

The north-west to south-east alignment of the wheel rut and surface, at a right-angle to the High Street, may indicate the route towards a stable at the rear of the street frontage.

Rut **93** (5m long, 0.3m wide and 0.07m deep) had gently sloping sides and a concave base. Its fill (99) was a pale grey brown silty sand with occasional gravel.

Layer 100 (3m long, 0.25m wide and 0.16m) consisted of small chalk blocks that had been compacted into a surface.

c) Drainage Ditches (Fig. 7)

Two ditches (**200=8** and **4**; Group 20) were located in Area 1. Both ditches were aligned north-west to south-east. It was suggested in the evaluation report that ditches **4** and **8** were hedge lines. Subsequent excavation revealed that ditch **8** continued southwards and was therefore re-interpreted as a drainage ditch. Ditch **4** was no longer visible.

Ditch **200** (see section drawing in Appendix 8) (same as **8** and **4**) (0.33m wide and 0.11m deep) had steep sides and a concave base. Its fill (201) was an olive brown silty clay with occasional flint inclusions that contained a small very abraded sherd of medieval pottery suggesting it was residual.

d) Clunch Built Boundary Walls (Fig. 7 and 8)

Three clunch-built walls were recorded (Group 21): wall **500** was identified in Area 4 and walls **1** and **9/245** exposed in 1999 Trench 1. Wall **1** possibly continued as wall **292** in 1999 Trench 5, some 80m to the north.

It is possible that the clunch wall identified in 1999 Trenches 1 and 5 (**1/292**) was associated with wall **500**, forming a right angle possibly related to an enclosure. Although, no direct relationship can be obtained between the different walls, projecting the two alignments (including the back boundary of No. 46 High Street) does create such a right-angled corner.

Wall **9/245** must have formed a separate structure although its common alignment with and its proximity to wall **1**, being only 3.5m away, suggest that together they may have demarcated an alleyway or lane leading from the High Street to the rear of the properties and the fields beyond.

**Wall 500**

The north-east to south-west alignment and location of wall **500** suggested that it may have been a continuation of the present back boundary of No 46 High Street. Its visible length within the excavation area was 14m. The wall was found on excavation to have different

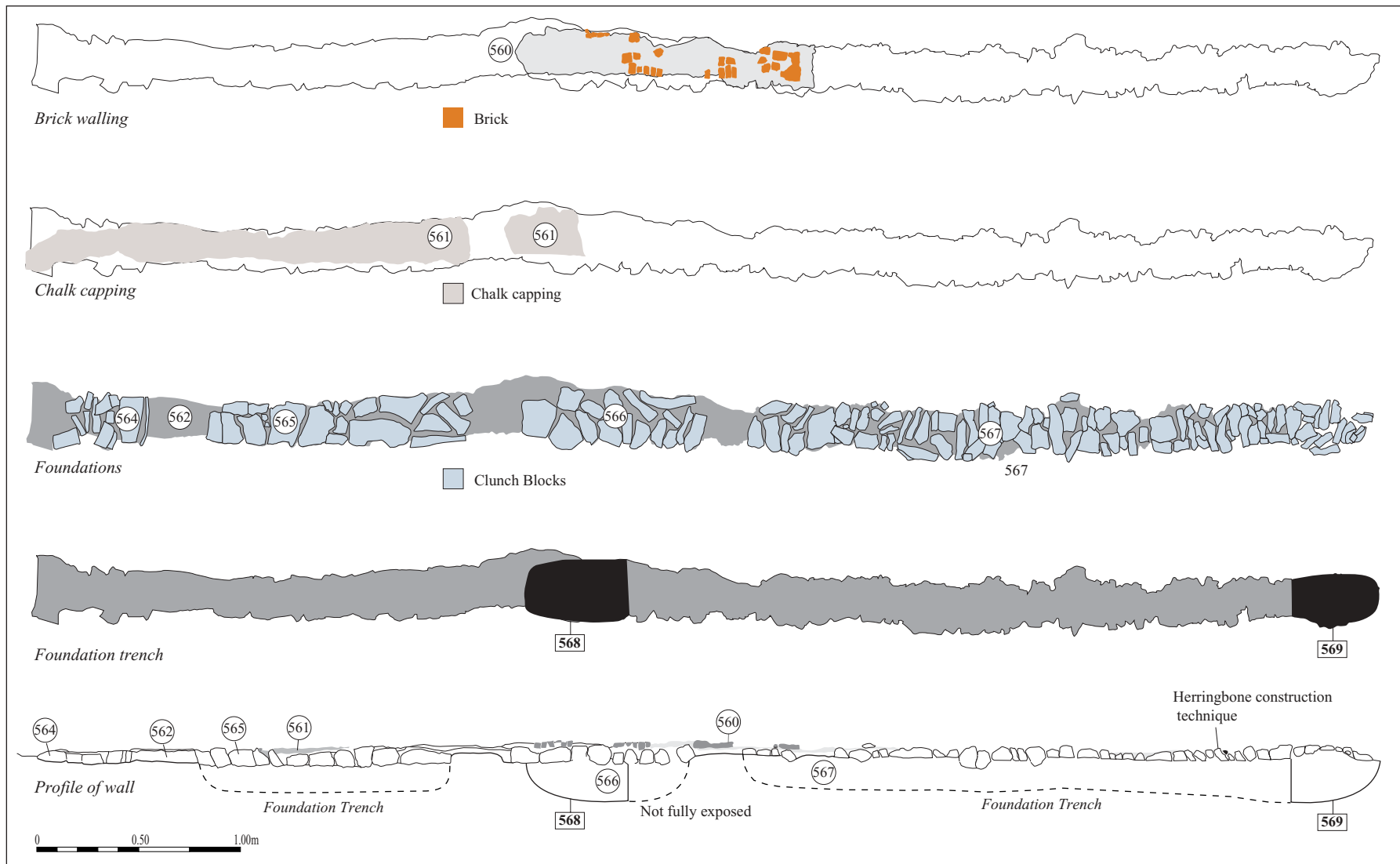

Figure 8 Detail plan and section of wall 500

stages of construction. The earliest stage consisted of four individual foundations (564 (unexcavated), 565 (unexcavated), 566 and 567) consisting of large and small clunch blocks.

Cut **568** of foundation 566 was 0.60m wide and 0.12m deep. The foundation consisted of closely packed clunch blocks and silty sand.

Cut **569** of ditch 567 was 0.44m wide and 0.14m deep (see section in Appendix 8). The foundation consisted of closely packed clunch blocks and silty sand.

On excavation wall **500** revealed two distinct methods of construction. Foundations 564, 565 and 566, indicated a haphazard construction technique, whereas foundation 567 showed evidence of a herring-bone construction technique.

The clunch blocks of all the foundation segments were bonded together by a greyish brown silty clay with frequent small flint inclusions (562) which contained a single fragment of clay-pipe stem. This bonding material had been hammered down into the voids between each clunch block and into the spaces between each segment of wall 500.

After the early stage of wall construction had been completed, a layer of white hammered chalk (561; 0.45m wide, 0.05m deep and 4.5m long) was used to cap the south-western end of the wall. Despite the absence of this chalk from the north-eastern end of the wall, some capping material must have originally existed in order to confer structural stability.

The last phase of visible construction of wall **500** consisted of brick walling (560). Its faces had been built using half bricks (0.06m wide, 0.05m wide and 0.11m long) bonded together by mortar. The void between the two wall faces was filled with brick rubble.

#### **Walls 1 and 9=245**

Walls **1=192** and **9=245** were identified in 1999 Trench 1. The walls ran parallel to each other and were aligned north-west to south-east, with the visible length being 76m for wall **1=292** and 12m for wall **9=245**. The two walls petered out towards the south-eastern baulk of Area 1.

#### e) **Drainage Ditches (Fig. 7)**

In 1999 Trench 6 elements of possible drainage ditches were located, two of which (**62** and **64**; Group 22) ran parallel to each other and were aligned north-east/south-west. The remaining possible drainage ditch (**63**), aligned north-west to south-east was positioned at a right-angle to the other two ditches.

Ditches **62** and **64** may have been drainage and/or internal property divisions parallel with the frontage, whilst ditch **63** probably separated two properties and was perpendicular to the frontage.

In 1999 Trench 5 (Group 23) was a single ditch (**289**) aligned north-west to south-east, with a visible length of 5m. The differing alignment of ditch **289** to the ditches recorded in 1999 Trench 6 cannot be easily explained as a boundary and this may have functioned as a drainage ditch.

Two parallel ditches (**62** and **64**) ran approximately 0.60m apart and extended beyond the boundaries of the trench. Ditch **62** had a visible length of 14.6m. A segment was excavated across this feature. Ditch **64** had a visible length of 3.8m and a single segment was excavated across it.



Ditch **63** was located 9m from the south-western end of the trench and at a right-angle to Ditch **62**.

Ditch **62** (0.7m wide and 0.3m deep) was aligned north-east to south-west. This ditch had steep sides and a flat base. Its fill (69) was a light grey clay silt with occasional flint nodules and gravel which contained two small, abraded sherds of medieval pottery, fragments of animal bone and a fragment of Niedermendig lava.

Ditch **64** (over 0.52m wide and 0.3m deep) was aligned north-east to south-west. Its sides were steep and the base was not revealed. Its fill (74) was not recorded.

Ditch **63** (0.85m wide and 0.3m deep) was aligned approximately north-west to south-east and had a near vertical eastern edge, a more gradually sloping western edge and a flat base. Its fill (70) was a mid-dark grey clay silt with occasional gravel, which contained fragments of animal bone and sherds of pottery (at least one of which was glazed).

Ditch **289** (see section in Appendix 8) (0.43m wide and 0.09m deep) had concave sides and a concave base. Its fill (288) was a brown sandy silt with occasional pea-grit which contained a residual sherd of Iron Age pottery.

f) Possible Structural Activity (Fig. 7)

Two undated beamslots (**66** and **67**; Group 24) were located 3.6m and 2.65m respectively from the north-eastern end of 1999 Trench 6. Both features were aligned north-west to south-east.

Beam slot **66** (0.55m wide, 1.54m long and 0.3m deep) was aligned north-east to south-west. Its sides were steep and had an abrupt break of slope and a flat base. Its fill (76) was of dark grey clay silt.

Beam slot **67** (0.3m wide, 1.4m long and 0.1m deep) aligned north-east/south-west, truncated 69. The sides were steep and had an abrupt break of slope and a flat base. Its fill (297) was not recorded.

g) Miscellaneous Pits (Fig. 7)

Three pits in Area 1 (Group 25) had been cut into the top of earlier ditches. They contained dark, relatively organic-rich fills and may have been late medieval or post-medieval in date.

Pit **228** (diameter 0.75m, 0.27 m deep and cut into the fills of ditch **218**) had gradually sloping sides and a flat base. Its fill (227) consisted of dark grey brown silty clay with occasional gravel.

Pit **214** (see section in Appendix 8) (2.7m long, 0.47m wide and 0.42m deep, oriented approximately east/west) had almost vertical sides and a flat base. Its fill (215) comprised very dark grey brown silty clay containing fragments of animal bone, shell and seven small fragments of abraded and probably residual medieval pottery.

Pit **211** (2.15m long, 0.55m wide and 0.18m), oriented approximately east/west) had almost vertical sides and a flat base. Its fill (210) consisted of dark greyish brown silt clay with occasional flints inclusions. A small, probably residual medieval rim sherd and fragments of animal bone were found.

## 5.5 Period 5: Modern

### 5.5.1 Phase 7: Village hut, Village hall construction and associated car park, erection of fences and pitting

#### a) Village Hut (Fig. 9)

Cartographic evidence (1887 Ordnance Survey Map, Fig. 2) and historical sources, together with local knowledge, indicate that the village hut (Group 26) was located towards the north-western corner of Area 1, although no evidence of the village hut was identified during the excavation. The village pond, however, which was also identified on the 1887 Ordnance Survey Map, was still present at the time of the excavation located at the south-eastern end of Area 1.

#### b) Construction of the Village Hall (Fig. 9)

Foundation trenches (Group 27) were identified in the north-western half of Area 1. Investigation in the north-western half of Area 3 revealed evidence of ground preparation before the construction of the village hall. This entailed the removal of natural chalk for a distance of 21m in a south-easterly direction from the north-western baulk to a depth of 0.50m. Ground preparation continued with the deposition of large amounts of clunch blocks within the machined area. The clunch blocks were then compacted in order to create a stable surface on which to construct the village hall.

#### c) Car Park (Fig. 9)

The car park is located 25m to the southeast of the north-western baulk of Area 1. Ground preparation (Group 28) occurred before the laying down of the car park surface, which involved the excavation of a damp area of the landscape resulting in a shallow rectangular pit (**556**).

Pit **556** (length 4m, 3.5m wide and 0.30m deep) had steep sides and a flat base. Its fill (555) was a sharp sand with occasional small stone inclusions.

#### d) Rubbish pits (Fig. 9)

Two pits modern pits were found (Group 29): pit **68** was located at the north-eastern end of 1999 Trench 6 and pit **20** on the north-eastern side of Area 3. Both pits produced modern debris which would seem to suggest that the land to the rear of the street frontage had become a dumping area.

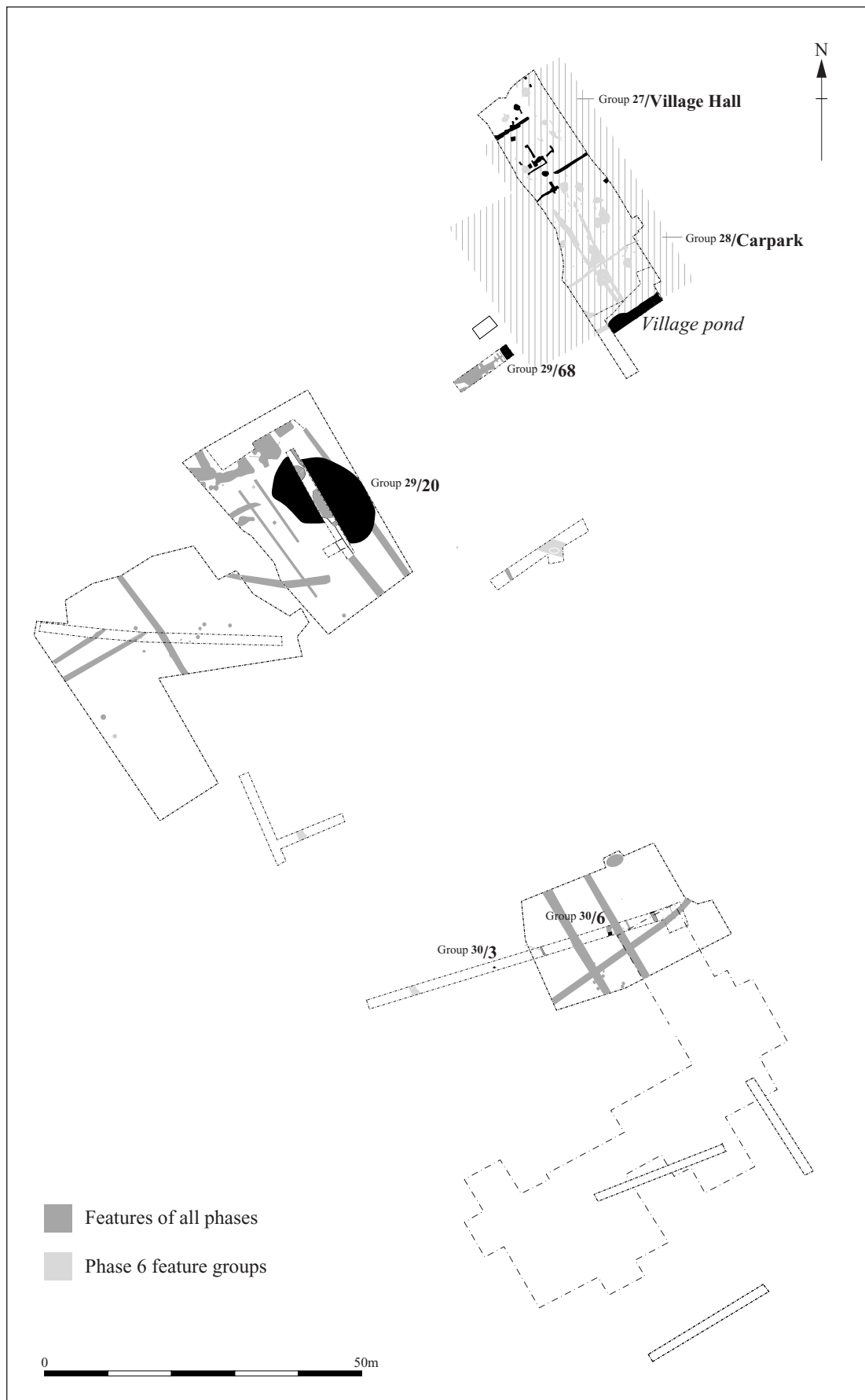

**Figure 9** Phase 7: Modern features

- e) Fence-line/boundary marker (Fig. 9)

Two postholes (**6** and **3**) were located 30m and 75m respectively from the north-eastern of 1999 Trench 1 (Group 30). Both of the postholes contained similar modern material. It is possible that these were the remnants of a former fence-line.

## 7 DISCUSSION AND CONCLUSIONS (Fig. 10)

The excavation to the rear of Foxton High Street has produced archaeological remains from the prehistoric, medieval and post-medieval periods, although the sparsity of finds from excavated features has hindered reliable dating. The investigation identified the geological depositional sequence as being mainly chalk in the southern and north-eastern part of the site, with gravel to the north, overlaid by approximately 0.3m of topsoil.

The early prehistoric archaeology is sparse within the development area and occurs in the form of residual worked flint, possibly attributable to the Bronze Age (Appendix 1). The presence of a burnt flint amongst the small assemblage may indicate knapping around hearths, close to the excavation area.

The Late Iron Age and Roman presence on the site is slight consisting of the presence of two cremations and a possible funeral pyre. These remains were broadly contemporary with the Iron Age and Roman settlements to the south (Scheduled Ancient Monument 216; Macaulay 1995), from which the few sherds of Roman pottery recovered may have derived. The cremations appear to be isolated, although surrounding features may have been ephemeral and were perhaps removed during subsequent agriculture (*i.e.* the orchard and deep ploughing for sugar beet cultivation).

The site initially appeared to be significant to the understanding of the development of medieval Foxton as part of the development area was thought to have been located within the historic village core. Excavation has now proved that this land was not utilised for domestic habitation during the medieval and post-medieval periods, but suggests rather that it was peripheral to the settlement and has been largely agricultural throughout its history.

The site produced limited artefactual and ecofactual evidence, the most significant find being the cremation vessel and associated human remains (Appendix 5). Finds were generally sparse although a small assemblage of medieval, post-medieval and modern metalwork was recovered during metal detecting (Appendix 4). Environmental remains indicate low density scatters of refuse, possibly including domestic and/or dietary waste (Appendix 7), while animal bones included the main domesticates with limited evidence for butchery, with no wild species or birds present (Appendix 6). Very little



**Figure 10 Phase plan showing projected alignments of medieval ditches and post-medieval walls**

pottery had been incorporated into the topsoil or subsoil as a result of manuring and it is possible that the development site was used as pasture until the recent past.

The features assigned to the medieval period (Phase 4) form part of a network of boundary ditches dividing-up the landscape into individual parcels of land. Two parallel ditches may indicate a minor route running parallel to the High Street, although this did not appear to continue eastwards for any distance.

A second, larger track at right angles to the other would have given direct access from the High Street to the outer fields. This subsequently shifted eastwards to the position of the modern lane. The alignment of the larger trackway can be seen partially preserved in the form of two rows of trees running north-west to south-east across the landscape on the 1887 OS map. It is probable that the ditches leading away from the High Street functioned as drainage ditches to take water away from the street frontage.

Further east, two converging medieval ditches found in Area 4 ran in a south-easterly direction towards the modern pond and away from an area known to flood. This may suggest an earlier date for the presence of a water catchment area or dew pond, although any evidence to confirm this suggestion had long since been eradicated by the excavation of the later pond.

Medieval pitting was evident, although the paucity of finds indicates that these were not associated with the intensive disposal of domestic waste. Environmental samples confirm the discard of extremely low levels of refuse, which may include domestic/dietary waste.

Post-medieval activity on the site indicates changes in land usage, moving away from agricultural practices within close proximity to the street frontage, to exploiting the land through the extraction of gravel. The very localised *ad hoc* quarrying activity suggests that the gravel extracted was for local consumption. The lack of artefactual material recovered from the pits indicates that rapid backfilling had taken place.

A change in the method used for the division of the landscape was also evident, moving away from ditch digging to the construction of walls. Material used in the construction of the one wall consisted of clunch blocks laid down in a shallow foundation trench, capped by hammered chalk on top of which bricks were laid bonded together by mortar. This wall may be a continuation of the boundary associated with the cottage located immediately to the west of the 2002 excavation, and it may have created pasture that could be used on seasonal basis. This is not to say that the area could not be used for arable purposes, although this form of usage would have been very limited when considering the continual water problem caused by the 'Common Stream' (the course of which ran along the route of the High Street) and its inability to cope with excessive quantities of water.

Evidence that water continued to be a major problem in this part of Foxton is provided by the fact that the village hut had to be erected on stilts, following

extensive ground work, as a means of aiding drainage. The constant problem of excessive water and how to combat its effect has played a major role in the development of the landscape in this part of Foxton.

## **ACKNOWLEDGEMENTS**

The author would like to thank H.C. Moss (Builders) Ltd who commissioned and funded the work on the development site. Thanks also to Tony Baker, Mark Hinman, Stephen Macaulay, Chris Montague, Cyril Pritchett and Diane Walls and staff from Bedfordshire Archaeological Service who worked on site; to Steven Kemp for the Total Station Survey; and Jon Cane, Caroline Malim and Leomie Willoughby-Ellis who worked on the illustrations for this report. Members of the Saffron Walden Metal Detectors Club carried out the metal detector survey. Thanks are also due to all the people who either volunteered on-site or offered information pertaining to the history of Foxton. The project was managed Mark Hinman, who also edited this report along with Elizabeth Shepherd Popescu.

The work was carried out in response to seven briefs for archaeological investigation issued by Andy Thomas, County Archaeology Office (Development Control), who visited the site and monitored the excavation.

## **BIBLIOGRAPHY**

British Geological Survey (BGS) Drift Sheet 205, 1952, reprinted 1970

EPNS (English Place Names Society), 1973, Vol. 19, *The place names of Cambridgeshire and the Isle of Ely*

Fosberry, R., 2000, *Earthwork Survey TL 4105/4823 Foxton, Cambridgeshire February 2000*

Kemp, S., 1994, *Archaeological Recording Brief at 40 High Street, Foxton*, AFU Report A38

Macaulay, S., 1995, *Herod's Farm, Foxton SAM 216 An Iron Age and Roman cropmark site*, AFU Report 118

Malim, T., 1990, *Archaeology on the Cambridgeshire County Farms Estate*

Malim, T., and Hines, J., 1998, *The Anglo-Saxon Cemetery at Edix Hill (Barrington A), Cambridgeshire*, Counc. Brit. Archaeol. Rep. 112

Maynard, D.J., Cleary, R., Moore, R., Brooks, I.P., and Price J., 1994, 'Excavations at Foxton, Cambridgeshire', in Price, J., Brooks, I.P., and Maynard, D.J. *The Archaeology of the St. Neots to Duxford Gas Pipeline*, Brit. Archaeol. Rep. Brit. Ser. 255

Parker, R., 1975, 'The common stream'

Roberts, J., 1998, *Prehistoric Features on land south of Foxton Recreation Ground*, AFU Report A141

Roberts, J., 2000, *Undated Remains to the south-west of Foxton Recreation Ground* AFU Report A169

Taylor, C., 1973, *The Cambridgeshire Landscape*

Wright, A.P.M., 1982, *Victoria History of the Counties of England: Cambridgeshire*, Vol. VIII South–West Cambridgeshire: Armingford and Thriplow Hundreds

Widdowson, E., 1973, *Cam or Rhee*

### **Maps consulted**

1810 pre-Enclosure map

1830 Enclosure map

1st edition OS 1887



## *Appendix 1: Lithic Analysis*

by Stephen N. Kemp

The majority of stone collected during excavation and from bulk sieving was heavily patinated flint. The worked flint all appears to have come from locally available material and is similar to the flint recovered as 'background' material during bulk sieving.

A small proportion of the flint appears to have been burnt, although firing was not to a high temperature.

Two fragments of vesicular lava from a single context (69) possibly represent the remains of a quern stone.

Humanly struck flint was recovered from six contexts. These are largely knapped flakes made from readily available material from the local environment. One of the scrapers is manufactured on a either a natural or very crudely struck flake.

The flakes are short and broad, and are the proximal end suggesting the distal end has been removed for use. The fine, uniform and restricted edge damage on some of these flakes indicates that these artefacts, which are usually the waste products of the manufacturing process, have been used as tools without any additional preparation. Their condition also suggests that they probably functioned as tools for short periods and were easily replaced.

Three scrapers were present within the excavated assemblage. As mentioned above one of these occurs on a presumed natural flake. The other two occur on secondary flakes. One is an end scraper from a small river cobble the other a side scraper, both was made on flakes. Three flint flakes have been burnt.

None of the artefacts are type fossils and therefore dateable to a specific period. The ease of manufacture and the crude forms, the lack of preparation and control, the use of natural flakes and the condition in which these artefacts have been disposed suggests readily available raw materials and an almost fortuitous use of knapping products for the manufacture of formal tools and usable pieces.

Given the small assemblage and its presence within a residual position over wide range of contexts, which is compounded by the lack of type fossils and other dating evidence it is difficult to be specific about the date of these artefacts. Given the knapping attributes it is likely that the assemblage is Bronze Age in date and as has been stated before is based on small river cobbles, which were readily available within the vicinity of the site.

The gravels along the River Cam are rich in Neolithic and Bronze Age activity sites and it is likely that this assemblage is part of this prehistoric use of the flood plain. The presence of a burnt flint flake within the assemblage is suggestive of prehistoric knapping around hearths close to the excavation area. It is likely that these activity areas and associated land surfaces on to which these artefacts were deposited have been truncated by later activity and are no longer in existence.

The table below lists stone collected during the evaluations and excavation. Unworked stone was recorded and discarded.

<b>Context</b>	<b>No. flints</b>	<b>Type</b>
58	1	scraper
212	2	flakes
221	2	proximal flakes
224	2	1 flake, 1 scraper
229	1	small flake
239	1	flake, possibly used as a borer
258	3	2 flakes, 1 borer

*Table 1: Worked flint by context*

*Appendix 2: Selected Prehistoric and Roman pottery*

by Paul Sealey

An almost complete mid-1st century butt beaker was associated with the cremated bone in context 127 within cremation **128** (Appendix 10, Plate 4). This has been dated to between AD 10-60.

Two sherds of a Late Iron Age/Early Roman (Gallo-Belgic) butt beaker were found in association with the cremation in pit **12**.

### Appendix 3: Medieval pottery

by Paul Spoerry

Context number	Pottery (kg)	Pottery Date
18	0.057	Medieval
22	0.028	Medieval
37	0.013	Medieval
49	0.070	Medieval
52	0.004	Medieval
58	0.057	900-1350
69	0.012	900-1150
70	0.007	1150-1350
85	0.034	1200-1400
86	0.009	1200-1400
101	0.003	1250-1400
103	0.024	1400-1560
116	0.180	1200-1400
201	0.002	Medieval
210	0.005	Medieval
212	0.002	Medieval
215	0.028	1200-1400
217	0.001	Medieval
246	0.004	Post-medieval
274	0.039	1400-1500
501	0.042	Medieval
502	0.000	1250-1350
508	0.041	1200-1400
514	0.270	1200-1400
520	0.025	1150-1350
540	0.049	900-1400
550	0.106	1200-1400
553	0.240	1200-1400
557	0.046	1250-1350
<b>Total</b>	<b>1.398</b>	

*Table App.3.1: Quantification of post-Roman pottery*

This small assemblage is mostly of quite fragmented medieval pottery. Many of the pieces are body sherds from shell-tempered vessels that cannot easily be assigned to a date-range of less than 200 years duration, thus making good dating difficult in many cases. Where least dateable, these pieces have been classified as either St Neots type ware or Shelly ware. Other examples can, however, be certainly classified as either St Neots type ware, or Shelly ware, giving approximate dates of 900-1150 and 1150-1350, respectively.

Virtually no pottery derives from the three major ditch systems/sequences and, unsurprisingly, little pottery was also recovered from postholes on the site.

Further work on this assemblage is not recommended.

*Appendix 4: Small finds catalogue and metal detector survey*

by Chris Montague

A systematic metal detector survey was carried out across the site and over spoil heaps on three separate occasions by Chris Montague and the Saffron Walden Metal Detectors Club, to determine the concentrations of ferrous and non-ferrous objects. Most of the finds noted below were recovered during metal detecting rather than excavated from identified contexts.

<b>Object</b>	<b>Description</b>	<b>Material</b>	<b>Date</b>
Jetton	Nuremberg	cu alloy?	16th c
Buckle		cu alloy?	13 - 14th c
Strap end		cu alloy?	13 - 14th c
Bag seal		lead?	19th c
Crottel bell		cu alloy and iron?	16 - 17th c
Harness rings x 2	horse furniture	cu alloy?	
Jetton	Nuremberg	cu alloy	16th c
Crottel bell	fragment	cu alloy	15 - 16th c
Bag seal		lead	19th c
Musket ball	rifle shot	lead	18 - 19th c
Rivet		cu alloy	18 - 19th c
Button	tunic button	pewter	18 - 19th c
Stud	furniture stud	cu alloy	18 - 19th c
Dross	3 fragments	lead	? - 19th c
Weight?	circular object	lead	? - 19th c
Coins	1 farthing, 2 ha'pennies	cu alloy	1927/1928
Nail	hand-made small	cu alloy	18 - 19th c

*Table 2: Metalwork*

## Appendix 5: Human Remains

by Corinne Duhig

### Summary

The remains were received in an upturned pot, the base of which had been broken in antiquity and compressed, with its contents, into the mid-part of the pot. In order to investigate the method of filling, it was decided to remove the cremated material in three layers from the pot base, its mid-part – now surrounding the base – and the upper pot/rim area. Methods used are those of Cho *et al* (1996) and Ubelaker (1989) for general bone analysis and McKinley (1989) for cremations.

### The Pot Fill

During exposure of the cremated material in the base, large portions of single bones were seen, although they were cracked through and could not be removed whole. A femoral head/neck/proximal shaft, a midshaft of tibia and part of a temporal bone of the skull (area of the petrous bone, auditory meatus, glenoid fossa and zygomatic root) were the most distinctive portions, but there were also shaft tubes from smaller long bones, including a radial head and proximal shaft. All were photographed *in situ*. There did not appear to be any arrangement of bones, not even a similar orientation of long bones, as might be expected for efficient filling of the container, but the disorder could have been produced if the pot had been broken before soil had filled it and fixed bones in position. Skull and long bones predominated, however, as described below.

The base contained 95% of all the bone, and by contrast only small fragments were present in the mid-part and even fewer, smaller fragments in the upper pot/rim. The material that was found outside the pot must have come from the mid-part or the uppermost level of the base, and been released when the pot was broken. It contained several large fragments of pelvis along with rib and some unidentifiable material; it appears, therefore, that in general skull and long bones were concentrated in the base of the pot, with pelvis above. As observed below on the charcoal, however, there is a possibility that this material was never within the pot and was deliberately deposited outside it.

### The Bone

After washing, the fragment size-range is mainly 1–3 cm maximum dimension but with many larger fragments (largest are two proximal femoral shafts, 8 cm and 6.5 cm in length, and a portion of vault 4.7 x 2.8 cm) and very little in the <4 mm range (the ‘small fraction’ which also contains small stones from the matrix). Bone from every area of the skeleton is present to at least some extent, with many distinctive fragments, for example from face and skull base (e.g. maxillary alveoli, zygomatic arches, inferior orbital rim), vertebral arches, sciatic notch and iliac crest of pelvis, heads of long bones and a metatarsal base; there are no teeth. The two proximal femoral shafts are from different sides but are of similar size, suggesting they are a pair. There is no other duplication of body parts evident, so one individual only is probably represented.

That this is an adult individual is shown by bone size and by the fused state of the epiphyses, but the vault sutures are unfused and age is therefore probably less than 35 years (Suchey in Cho *et al.* 1996). The sex can not be determined and no pathological conditions identified.

### Pyre Technology and Depositional Practice

The sample ranges in colour from creamy-white to black, and a considerable proportion, particularly in the diploë of the skull vault and within the long bone shafts, is patched blue-grey and black, indicating that burning was not sufficient to remove all the organic component of bone in these areas. McKinley finds that a temperature of at least 500°C, with the pyre maintained for 7 to 8 hours, is necessary for complete combustion, but Mays (1998) finds 645°C the minimum and Shipman *et al.* (1984) 940°C. Sufficient to say that most archaeological cremations are very well burned, and this one is slightly less well-burned than the usual.

Weights and per centages of the fractions, shown below, confirm that skull and long bones dominate the sample and the skull is at a higher proportion than in McKinley's 'ideal' cremation (where per centages are skull 18.2%, axial skeleton 23.1%, limbs 58%).

Beakdown of sample	Weight (g)	% of whole	% of identified bone
skull	68	30.6	33.7
axial skeleton	23	10.4	11.4
limbs/extremities	111	50.0	54.9
all identified bone	202	91.0	100.0
unidentified	20	9.0	–
total	222	100.0	–
small fraction	29	–	–

Table 3: Human Remains

Weight of bone is at the bottom end of the range for archaeological cremations, 200–2000 g (McKinley 1989; Mays 1993), and emptying of the pot showed that it was only about half full. Two fragments of animal bone were commingled with the human bone in the base of the pot. No other non-human burnt material was found in the fill, although a bag of charcoal with a few tiny burnt bone flakes accompanies the material from outside the pot. It is not impossible, but stretching credibility, that all the charcoal escaped when the pot was broken; it appears more likely that the bones were deliberately placed in the pot without other pyre residue.

## References

- Cho, H., A.B. Falsetti, J. McIlwaine, C. Roberts, P.S. Sledzik & A.W. Willcox. 1996. *Handbook of the Forensic Anthropology Course of the Department of Archaeological Sciences*, University of Bradford and the NMHM/AFIP, Washington D.C.
- McKinley, J.I. 1989. Cremations: expectations, methodologies and realities. In C.A. Roberts, F. Lee & J. Bintliff (eds.), *Burial archaeology. Current research, methods and developments*: 65–76. Oxford: British Archaeological Reports (BAR British Series 211).
- Mays, S. 1998. *The archaeology of human bones*. London: Routledge.
- Mays, S. 1993. *The human bone from Godmanchester, Cambridgeshire (1988–1992 excavations)*. (AML Report 39/93). London: English Heritage.
- Shipman, P, G. Foster & M. Schoeninger. 1984. Burnt bones and teeth: an experimental study of colour, morphology, crystal structure and shrinkage. *Journal of Archaeological Science* 11: 307–25.
- Ubelaker, D.H. 1989. *Human skeletal remains: excavation, analysis, interpretation*. (Manuals on Archaeology 2). Washington: Taraxacum for Smithsonian Institution.

## Appendix 6: Faunal Remains

by Ian Baxter

### Introduction

A very small quantity of animal bone was recovered by hand from excavated features. Fragments have been identified to species or size of animal where possible. The bones forming the subject of this report are assumed to date from all phases of occupation of the site. The bone was very variable in its preservation with condition ranging from poor to good. Most of the unidentified material is highly fragmented. All identified and 'countable' fragments are recorded on an Access database. This is a tiny assemblage precluding any detailed analysis.

### Methods

All of the animal bones from High Street, Foxton were hand-collected and an under-representation of smaller species and body parts is to be expected from this site.

The mammal bones were recorded following a modified version of the method described in Davis (1992) and Albarella *et al* (1997). In brief, all teeth (lower and upper) and a restricted suite of parts of the postcranial skeleton were recorded and used in counts. These are: horn cores with a complete basal cross section, skull (zygomaticus), atlas, axis, scapula (glenoid articulation), distal humerus, distal radius, proximal ulna, carpal 2+3, radial carpal, distal metacarpal, pelvis (ischial part of acetabulum), distal femur, distal tibia, calcaneum (sustenaculum), astragalus (lateral side), centrotarsale, distal metatarsal, proximal parts of the 1st, 2nd and 3rd phalanges. At least 50% of a given part had to be present for it to be counted. The presence of large (cattle/horse size) and medium (sheep/pig size) vertebrae and ribs was recorded for each context, although these were not counted. The separation of sheep and goat was not attempted.

### Quantification

Context	
18	cow molar, 3 mm rib frags, mm tibia, mm ulna frag., 1 shaft frag
22	immature pig jaw, mm humerus, distal end
25	fragments lm skull (horse?), 2 mm rib frags, 1 frag mm tibia
49	sheep/goat molar
58	1 immature bovine tooth, 1 sh/goat tooth, 7 frags
69	1 sh/goat scapula frag, distal end cow humerus, with butchery marks
70	frags immature cow skull, 1 mm shaft frag.
71	3 lm shaft frags
85	2 mm shaft frags
210	distal end lm femur, 1 unid frag.
215	2 lm teeth, 2 lm shaft frags, 1 sh/goat tooth, distal end sh/goat tibia
239	8 lm limb frags
258	1 sh/goat tooth
268	immature cattle skeleton (almost complete)
273	1 proximal end lm radius
274	2 lm shaft frags, 1 sh/goat shaft frag
mm	medium mammal – sheep/goat/pig sized
lm	large mammal

Table 4: Animal bone by context

Where the bone is heavily eroded or too fragmented the size of animal only has been estimated. Age of animal has been estimated fusion of epiphyses/tooth wear or eruption.

### **Discussion and Conclusion**

This is a very small assemblage and little can be said regarding age profiles or husbandry practices at the site. However, the main domestic food species are represented and butchery marks were noted on at least one bone. No bird bones or wild species were identified.



## **Introduction**

Three samples were taken for assessment of the plant macrofossil assemblages. These were taken from posthole **579** (Sample 2), pit **559** (Sample 3) and pit **521** (Sample 4), all of which were assigned to Period 3, Phase 5.

## **Methods**

The samples were processed by a member of the Archaeological Field Unit team, collecting the flots in a 500 micron mesh sieve. The dried flots were scanned under a binocular microscope at magnifications up to x 16, and the plant macrofossils and other remains noted are listed on Table 1. Nomenclature within the table follows Stace (1997). Whilst most plant remains were preserved by charring, un-charred seeds of meadow/creeping/bulbous buttercup (*Ranunculus acris/repens/ bulbosus*) and elderberry (*Sambucus nigra*) were noted. Although these may be modern in origin, both seeds have a woody endocarp and can persist, even in well-aerated archaeological deposits, for a considerable period.

## **Results of Assessment**

### *Plant Remains*

Cereal remains and/or seeds/fruits of common weed plants are present at low to moderate densities in all three samples. Preservation of the macrofossils is poor to moderate; a high number of the cereal grains are severely puffed and distorted as a result of charring at very high temperatures.

### *Cereals*

Oat (*Avena* sp.) and/or wheat (*Triticum* sp.) grains are recorded at very low densities in samples 3 and 4. A higher number of indeterminate grains are present throughout, but all are far too distorted for positive identification. A single bread wheat (*T. aestivum/compactum*) type rachis node is present in Sample 4.

### *Wild Flora*

Seeds/fruits are extremely rare and are only recorded as single specimens. Taxa noted include stinking mayweed (*Anthemis cotula*), shepherds needle (*Scandix pecten-veneris*) and an indeterminate large grass (Poaceae). Fragmentary elderberry seeds are present in Sample 2.

### *Other Plant Macrofossils*

Charcoal fragments are present throughout. Other plant remains are extremely rare but indeterminate seeds are recorded from Sample 2.

### *Molluscs*

Mollusc shells are present at a low density in all three samples, with open country species being predominant. However, it should be noted that the specimens from Sample 2 may be modern in origin, as surface structures and colouration are well preserved. The shells from samples 3 and 4 appear slightly more abraded, but it is not possible to categorically state whether they are contemporary with the contexts.

### *Other Materials*

The pieces of black porous 'cokey' material in Sample 4 may be derived from the combustion of organic materials (including cereal grains) at extremely high temperatures. The fragments of eggshell, fish and mammal bone may be dietary refuse. Small mammal and/or amphibian bones are also present.

### *Discussion*

The composition of the assemblages appears to be consistent with their being derived from extremely low density scatters of refuse, possibly including some domestic/dietary waste. Although the origin of the cereal grains is uncertain, they may be indicative of small quantities of hearth waste.

### *Conclusions and Recommendations for Further Work*

In conclusion, plant macrofossils are rare in all three samples. The material present appears to be derived from low density scatters of refuse, possibly from domestic sources.

As none of the samples produced quantifiable assemblages (i.e. 100 plus specimens), and as the precise origin of the material is far from certain, it is unlikely that further analysis would add to the interpretation of the site or its component features. Therefore, no further work is recommended.

### *References*

Stace, C., 1997, *New Flora of the British Isles*. Second edition.

Sample No.	2	3	4
Context No.	580	557	522
Cereals			
<i>Avena</i> sp. (grain)		x	
Cereal indet. (grains)	x	x	xx
<i>Triticum</i> sp. (grains)		x	x
<i>T. aestivum/compactum</i> type (rachis nodes)			x
Herbs			
<i>Anthemis cotula</i> L.		x	
Large Poaceae indet.		x	
<i>Ranunculus acris/repens/bulbosus</i>	xnc		
<i>Scandix pecten-veneris</i> L.		xcf	
Trees/shrubs			
<i>Sambucus nigra</i> L.	xnc		
Other plant macrofossils			
Charcoal <2mm	xxx	xx	xx
Charcoal >2mm	xx		x
Indet.seeds	x		
Molluscs			
Open country species			
<i>Helicella itala</i>			x
<i>Pupilla muscorum</i>	x		
<i>Vallonia costata</i>		x	x
<i>V. excentrica</i>		x	
<i>V. pulchella</i>	x		x
Catholic species			
<i>Cochlicopa</i> sp.	x	x	x
<i>Trichia hispida</i> group	x	xx	
Other materials			
Black porous 'cokey' material			xx
Eggshell		x	
Fish bone	x	x	x
Mammal bone	x	x	x
Small mammal/amphibian bone	x	x	x
Sample Volume (litres)			
Volume of flot (litres)	0.1	<0.1	<0.1
% flot sorted	100%	100%	100%

Table 5: Plant remains

Key to Table

x = 1 – 10 specimens    xx = 10 – 100 specimens    xxx = 100+ specimens

FOX HS 01

Sample Number	Context Number	Initial Volume	Volume processed	FLOT				RESIDUE					Comment	
				Grain	Seeds	Charcoal	Bone	Grain	Seeds	Charcoal	Bones			Pot
											Sml	Large		
2	580	5	5	0	##	#####	0	0	#	#	#	#	0	At least 7 different weed seeds. Fish scale and ?mineralisation.
3	577	10	10	##	#	#	#	#	0	#	#	#	0	Slightly better preservation of cereals.
4	522	10	10	##	#	#	#	#	0	0	#	0	0	Poor preservation of cereals. Fish scale

Table 6: Samples from FOX HS 01

**Appendix 8: Section drawings**

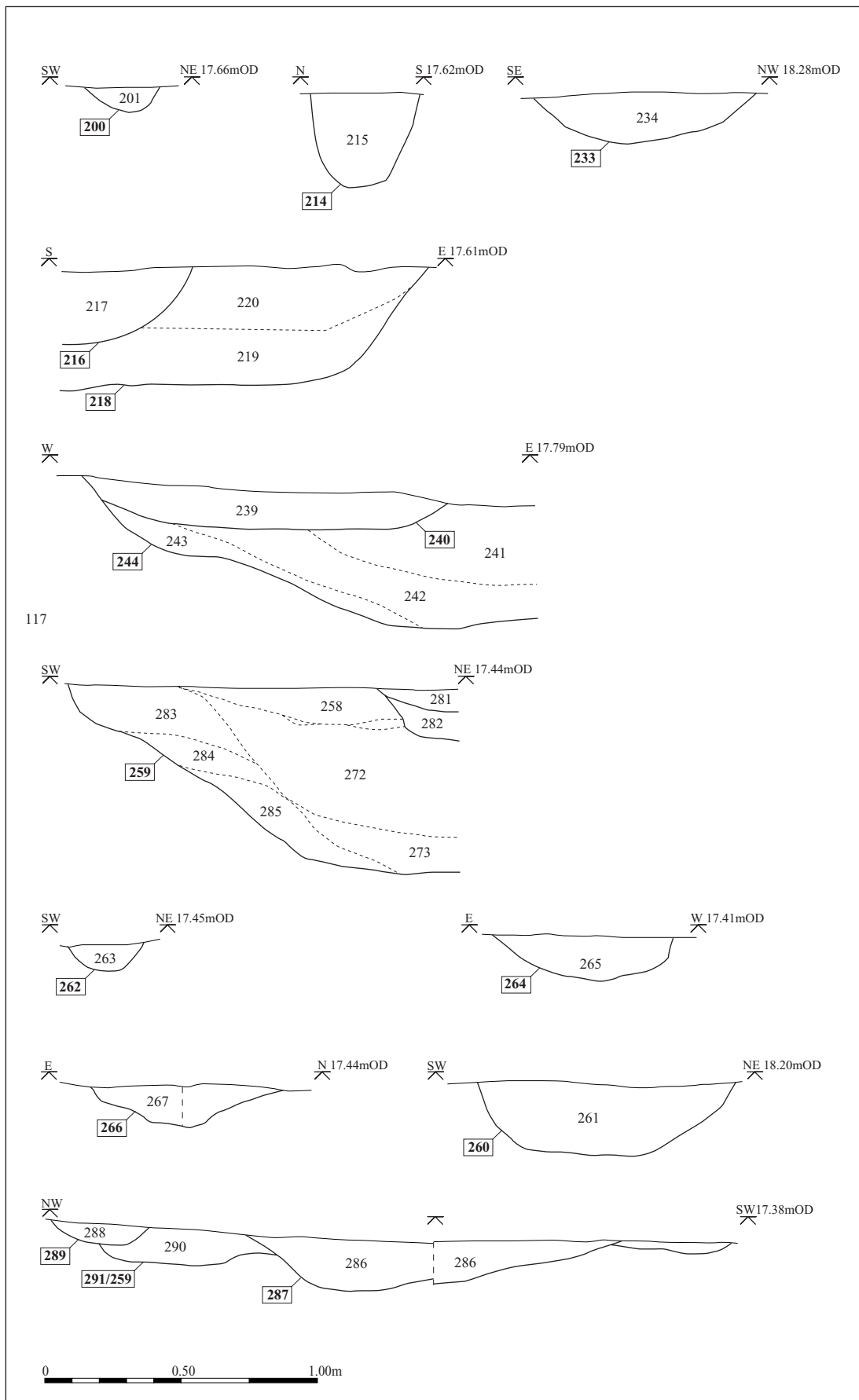

Appendix 8: Section drawings (cont.)

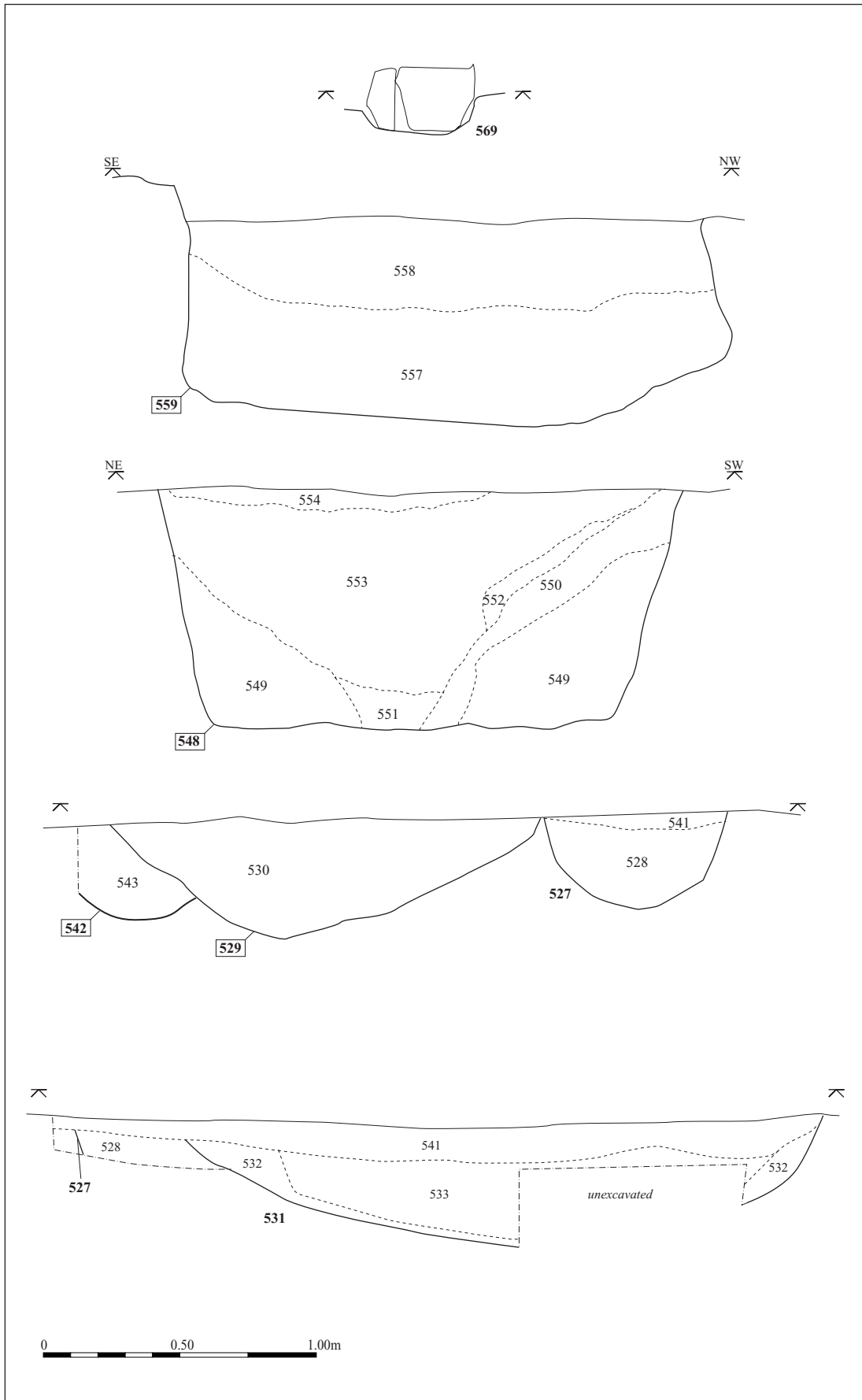

Appendix 9: Context Records

**Stage 3/4 Evaluation and Watching Brief 1999**

Context No	Fill of	Filled by	Context type	Description
1				Topsoil
2		30,31,32	Ditch cut	Linear ditch, steep sided, flat base
3			Posthole cut	Circular, steep sided, concave base
4			Hedgeline cut	Linear ditch, moderate sides, concave base
5		33,34,35,36	Ditch cut	Linear ditch, steep sided, flat base
6			Pit cut	Modern feature
7		37,38,39	Ditch cut	Linear ditch, steep sided, flat base
8			Hedgeline cut	Linear ditch, moderate sides, concave base
9			Ditch cut	Wall foundation
11		41,42	Ditch cut	Linear ditch, steep sided, flat base
12		55	Cremation pit cut	Oval, steep sided, concave base
13				Hearth base
14			Pit cut	Circular, moderate sides, concave base
15			Ditch cut	Linear ditch, moderate sides, concave base
16			Posthole cut	Circular, steep sides, flat base
17			Ditch re-cut	Linear ditch, moderate sides, concave base
18	21		Ditch fill	Greyish brown sandy silt deposit
19	21		Ditch fill	Brown sandy silt deposit
20	21		Ditch fill	mid-brown sandy silt deposit
21		18,19,20	Ditch cut	Linear ditch, moderate sides, concave base
22	23,24		Pit and ditch fill	Light brown clayey silt deposit
23		22	Pit cut	Circular, steep sided, flat base
24		22	Ditch cut	Linear ditch, steep sided, concave base
25	26		Ditch fill	Light brownish grey sandy clay deposit
26		25	Ditch cut	Linear ditch, steep sided, flat base
27	28		Ditch fill	Light grey clay silt deposit
28	27		Ditch cut	Linear ditch, steep sided, flat base
29		106	Pit/ditch cut	Unexcavated
30	2		Ditch fill	Orange grey sandy clay deposit
31	2		Ditch fill	mid-grey sandy silt deposit
32	2		Ditch fill	mid-grey sandy silt deposit
33	5		Ditch fill	Orange grey sandy clay deposit
34	5		Ditch fill	mid-grey sandy silt deposit
35	5		Ditch fill	Greyish white chalky clay silt deposit
36	5		Ditch fill	Greyish white chalky clay silt deposit
37	7		Ditch fill	Orange grey sandy clay deposit
38	7		Ditch fill	Greyish white chalky clay silt deposit
39	7		Ditch fill	Greyish white chalky clay silt deposit
40	10		Ditch fill	Greyish brown clayey silt deposit
41	11		Ditch fill	Orange grey sandy clay deposit
42	11		Ditch fill	mid-grey sandy silt deposit
43	3		Posthole fill	Grey brown clayey silt deposit
44	4		Fence line fill	mid-grey brown sandy silt
45	6		Modern Pit fill	
46	8		Fence line fill	
47	9		Ditch fill	Wall capping in ditch
48	9		Ditch fill	Wall foundation material (clunch)
49	50		Ditch fill	Brown sandy silt deposit
50		49	Ditch re-cut	Linear ditch moderate sides concave base
51			Ditch fill	Brown sandy silt deposit
52			Ditch fill	Brown sandy silt deposit
53	14		Pit fill	Greyish brown clayey silt deposit

<b>Context No</b>	<b>Fill of</b>	<b>Filled by</b>	<b>Context type</b>	<b>Description</b>
54	13		Hearth fill	
55	12		Pit fill	mid-greyish brown silty sandy deposit (cremation)
56	57		Pit fill	mid-greyish brown silty sandy deposit
57		56	Pit cut	Circular, steep sides, concave base
58	59		Pit fill	Greyish brown silty sandy deposit
59		58	Pit cut	Circular, steep sides, concave base
60	61		Ditch fill	Brown sandy silt deposit
61		60	Ditch cut	Linear ditch moderate sides concave base
62		69	Ditch cut	Linear ditch, steep sided, flat base
63		70	Ditch cut	Linear ditch, gradual sides, flat base
64		74	Ditch cut	Linear ditch, steep sided, flat base
65		75	Pit cut	Sub-circular, steep sided, flat base
66		76	Beamslot cut	Linear ditch, steep sided, flat base
67		297	Beamslot cut	Linear ditch, steep sided, flat base
68			Quarry cut	Modern disturbance
69	62		Ditch fill	Light grey clayey silt deposit
70	63		Ditch fill	Dark grey clayey silt deposit
71	73		Quarry fill	Orange brown sandy silty deposit
72	73		Quarry fill	Light grey chalky clay silt deposit
73		71,72	Quarry cut	Modern
74	64		Ditch fill	Dark grey clayey silt deposit
75	65		Posthole fill	Grey brown clayey silt deposit
76	66		Ditch fill	Dark grey clayey silt deposit
77		87	Ditch cut	Linear ditch, moderate sides, flat base
78		88	Hollow cut	Sub-rectangular, steep sided, flat base
79		85	Pit cut	Sub-circular, moderate sides, flat base
80		89	Pit cut	Sub-rectangular, steep sided, flat base
81		90	Pit cut	Oval, steep sided, concave base
82		86	Pit cut	Sub-circular, moderate sides, flat base
83		91	Pit cut	Circular, moderate sides, concave base
84		92	Posthole cut	Sub-circular, steep sided, flat base
85	79		Pit fill	Pale greyish brown silty clay deposit
86	82		Pit fill	Pale greyish brown silty sandy deposit
87	77		Ditch fill	Pale greyish brown silty clay deposit
88	78		Hollow fill	Pale orange brown silty sandy deposit
89	80		Pit fill	Pale greyish brown silty sandy deposit
90	81		Pit fill	Pale greyish brown silty sandy deposit
91	83		Ditch fill	Pale greyish brown silty sandy deposit
92	84		Posthole fill	Pale orange brown silty sandy deposit
93		99,100	Rut cut	Wheel rut
94		101	Pit cut	Sub-rectangular, steep sided, flat base
95		108	Posthole cut	Sub-circular, steep sided, flat base
96		102	Pit cut	Sub-circular, steep sided, flat base
97		103	Pit cut	Oval, steep sided, concave base
98		104	Pit cut	Oval, shallow sided, concave base. (fire pit)
99	93		Wheel rut fill	Pale greyish brown silty sandy deposit
100	93		Layer	Off white chalky silt deposit
101	94		Pit fill	Pale greyish brown silty clay deposit
102	96		Pit fill	Pale greyish brown silty clay deposit
103	97		Pit fill	Mid-greyish brown silty sandy deposit (modern)
104	98		Fire pit cut	Pinkish white compacted chalk deposit
105	109		Pit fill	Mid-greyish brown silty sandy deposit
107			Pit cut	Unexcavated
108	95		Pit cut	Pale greyish brown silty clay deposit
109		105	Ditch cut	Linear ditch butt-end, shallow sided, concave base
110	111		Ditch fill	Light orange brown sandy clay deposit



Context No	Fill of	Filled by	Context type	Description
111		110	Ditch cut	Linear ditch, steep sided, flat base
112	113		Posthole fill	Mid-grey brown sandy clay deposit
113		112	Posthole fill	Sub-rectangular, steep sided, irregular base
114	115		Posthole fill	Mid-grey brown sandy clay deposit
115		114	Posthole cut	Circular, steep sided, concave base
116	117		Pit fill	Mid-grey brown sandy clay deposit
117		116	Pit cut	Linear ditch, steep sided, flat base
118	119		Pit fill	Pale greyish brown silty clay deposit
119		118	Pit cut	Rectangular, steep sided, flat base
120	122		Ditch fill	Brownish grey clay silty deposit
121	122		Ditch fill	Light grey chalky clay silt deposit
122		120, 121	Ditch cut	Linear ditch, steep sided, concave base
123	124		Ditch fill	Light orange brown sandy clay silt deposit
124		123	Ditch cut	Linear ditch, steep sided, flat base
125	128		Pit fill	Orange grey sandy silt deposit
126	128		Cremation pit fill	mid-grey brown sandy silt deposit
127	128		Cremation pot fill	Cremation pot
128		125, 126, 127	Cremation cut	Irregular steep sided, flat base

## Stage 2 Excavation of Areas 1 and 2

Context No	Fill of	Filled by	Context type	Description
200		201	Ditch cut	Linear ditch, steep sided, concave base
201	200		Ditch fill	Olive brown silty clay deposit
202	203		Ditch fill	Brown clay sand deposit
203		202	Ditch cut	Linear ditch, steep sided, concave base
204	206		Ditch fill	Light greyish brown clayey sand deposit
205	206		Ditch fill	Light grey clay deposit
206		204,205	Ditch cut	Linear ditch, steep sided, irregular base
207				Topsoil
208				Subsoil
209				Natural
210	211		Pit fill	Dark greyish brown silty clay deposit
211		210	Pit cut	Linear ditch, steep sided, flat base
212	213		Ditch fill	Light brownish grey clayey silt deposit
213		212	Ditch cut	Linear ditch, shallow sided, flat base
214		215	Pit cut	Elongated, steep sided, flat base
215	214		Pit fill	Brownish grey silty clay deposit
216		217	Ditch cut	Linear ditch, steep sided, flat base
217	216		Ditch fill	Brown silty clay deposit
218		219, 220	Ditch cut	Linear ditch, steep sided, flat base
219	218		Ditch fill	Grey clay deposit
220	218		Ditch fill	Brownish grey silty clay deposit
221	223		Ditch fill	Light reddish brown sandy clay deposit
222	223		Ditch fill	Light reddish brown sandy clay deposit
223		221,222	Ditch cut	Linear ditch, steep sided, irregular base
224	226		Ditch fill	Light reddish brown sandy clay deposit
225	226		Ditch fill	Light grey clay deposit
226		224, 225	Ditch cut	Linear ditch , steep sided, concave base
227	228		Pit fill	Dark greyish brown silty clay deposit
228		227	Pit cut	Circular, shallow sided, flat base
229	230		Pit fill	Pale brown clayey silt deposit
230		229	Pit cut	Circular, shallow sided, flat base
231	232		Pit fill	Grey clayey silt deposit
232		231	Pit cut	Circular, shallow sided, flat base
233		234	Ditch cut	Linear ditch, moderate sides, flat base

<b>Context No</b>	<b>Fill of</b>	<b>Filled by</b>	<b>Context type</b>	<b>Description</b>
234	233		Ditch fill	Greyish brown silty clay deposit
235	235		Pit fill	Light brown clayey silt deposit
236		235	Pit cut	Oval, gradual sided, flat base
237	238		Pit fill	Light brown clayey silt deposit
238		237	Pit cut	Oval, gradual sided, flat base
239	240		Pit fill	Dark greyish brown clayey silt deposit
240		239	Pit cut	Sub-circular, steep sided, flat base
241	244		Pit fill	Pale brown clayey silt deposit
242	244		Pit fill	Greyish brown silty clay deposit
243	244		Pit fill	Pale brown clayey silt deposit
244		241, 242,243	Pit cut	Circular, moderately sided, flat base
245		246	Drain cut	Modern drain
246	245		Drain fill	Modern fill
247	249		Pit fill	Dark brown sandy silt deposit
248	249		Pit fill	Dark brown sandy silt deposit
249		247, 248	Pit cut	Oval, steep sided, flat base
250	251		Pit fill	Dark brown sandy silt deposit
251		250	Pit cut	Oval, steep sided, flat base
252	257		Ditch fill	Dark brown sandy silt deposit
253	257		Ditch fill	Dark brown sandy silt deposit
254	257		Ditch fill	Dark brown sandy silt deposit
255	257		Ditch fill	Reddish brown sandy deposit
256	257		Ditch fill	Dark brown sandy silt deposit
257		252,253,254, 255, 256	Ditch cut	Linear ditch, steep sided, flat base
258	259		Ditch fill	Brownish grey silty clay deposit
259		258,272,273, 281, 283	Ditch cut	Curvilinear ditch, steep sided, flat base
260		261	Ditch cut	Linear ditch, steep sided, flat base
261	260		Ditch fill	Greyish brown sandy silty deposit
262		263	Posthole cut	Sub-circular, moderate sides, concave base
263	262		Posthole fill	Brown sandy silty deposit
264		265	Pit cut	Oval, moderate sides, flat base
265	264		Pit fill	Dark brown silty clay deposit
266		267	Ditch cut	Linear ditch, shallow sided, flat base
267	266		Ditch fill	Dark brown silty clay deposit
268	269		Pit fill	Dark greyish brown clayey silt deposit
269		268	Pit cut	Sub-circular, moderate sides, concave base
270	271		Pit fill	Greyish brown silty sandy deposit
271		270	Pit cut	Oval, steep sided, concave base
272	259		Ditch fill	Light grey clay deposit
273	259		Ditch fill	Brownish grey clayey sandy deposit
274	275		Pit fill	mid brown clay silt deposit
275		274	Pit cut	Oval, shallow sided, irregular base
276		277	Posthole cut	Circular, shallow sided, concave base
277	276		Posthole fill	Greyish brown sandy silt deposit
278			Tree throw	Olive brown sandy silt deposit
279		280	Ditch cut	Linear ditch, shallow sided, concave base
280	279		Ditch fill	Olive brown sandy silt deposit
281	259		Ditch fill	Brown silty sandy deposit
282	259		Ditch fill	Brown silty sandy deposit
283	259		Ditch fill	Greyish brown sandy silt deposit
284	259		Ditch fill	Brownish grey clayey sandy deposit
285	259		Ditch fill	Brown silty sandy deposit
286	287		Pit fill	Light brownish grey clay silty deposit
287		286	Pit cut	Oval, moderately sided, concave base
288	289		Ditch fill	Brown silty sandy deposit
289		288	Ditch cut	Linear ditch, shallow sided, irregular base
290	291		Ditch fill	Light brownish grey clay silt deposit

Context No	Fill of	Filled by	Context type	Description
291		290	Ditch cut	Curvilinear ditch

#### Stage 5/6 Evaluation 2000 (monitoring)

Context No	Fill of	Filled by	Context type	Description
100	101		Ditch fill	Mid brown fine sand deposit
101		100	Ditch cut	Linear ditch, steep sided.
102	103		Ditch fill	Dark brown fine sand deposit
103		102	Ditch cut	Linear ditch, steep sided. Concave base
104			Layer	Mid brown fine sand deposit
105			Natural	Natural chalk
106	107		Ditch fill	Mid brown fine sand deposit
107		106	Ditch cut	Linear ditch, steep sided. Concave base
108	109		Ditch fill	Dark brown silty deposit
109		108	Ditch cut	Linear ditch, steep sided. flat base
110	111		Ditch fill	Light brown fine sandy deposit
111		110	Ditch cut	Linear ditch, steep sided. Concave base
112	113		Ditch fill	Dark brown fine sandy deposit
113		112	Ditch cut	Linear ditch, steep sided. flat base
114	115		Ditch fill	Mid brown fine sand deposit
115		114	Ditch cut	Linear ditch, steep sided. flat base
116	117		Ditch fill	Mid brown fine sand deposit
117		116	Ditch terminal	Linear ditch, steep sided, flat base
118				Topsoil
119	121		Ditch/pit fill	Yellowish brown sandy silt deposit
120	121		Ditch/pit fill	Mid-yellowish brown clayey silt deposited
121		119,120, 124	Ditch/pit cut	Not enough evidence to determine feature form
122	123		Ditch/pit fill	Yellowish brown sandy silt deposit
123		122	Ditch/pit cut	Not enough evidence to determine feature form
124	121		Ditch/pit fill	Pale yellowish brown sandy silt deposit
125	128		Pit fill	Dark greyish brown sandy silty deposit
126	128		Pit fill	Pale brown sandy clayey silt deposit
127	128		Pit fill	Pale yellowish brown sandy silt deposit
128		125, 126, 127	Pit cut	Circular, steep sided, concave base

#### Stage 7 2002 Excavation

Context No	Fill of	Filled by	Context type	Description
500			wall	Foundation of clunch wall
501		502	Pit cut	Sub-circular, shallow sided, irregular base
502	501		Pit fill	mid-brown clayey silt deposit
503		504	Pit cut	Sub-rectangular, shallow sided, irregular base
504	503		Pit fill	Grey sandy silt deposit
505		506	Pit cut	Irregular, shallow sided, irregular base
506	505		Pit fill	Grey sandy silt deposit
507		508	Pit cut	Sub-rectangular, steep sided, concave base
508	507		Pit fill	mid-grey brown sandy silt deposit
509		510	Pit cut	Sub-circular, steep sided, concave base
510	509		Pit fill	mid-brown clayey silt deposit
511		512	Pit cut	
512	511		Pit fill	
513		514	Posthole cut	
514	513		Posthole fill	
515		516	Posthole cut	Circular, steep sided, flat base

<b>Context No</b>	<b>Fill of</b>	<b>Filled by</b>	<b>Context type</b>	<b>Description</b>
516	515		Posthole fill	mid-brown clayey silt deposit
517		518,519,520	Pit cut	Oval, steep sided, flat base
518	517		Pit fill	Pale brown sandy clay deposit
519	517		Pit fill	Brownish yellow sandy silt deposit
520	517		Pit fill	Brown sandy silt deposit
521		522	Pit cut	Sub-circular, shallow sided, irregular base
522	521		Pit fill	Light grey sandy silt deposit
523		524	Ditch cut	Linear ditch, steep sided, concave base
524	523		Ditch fill	Pale brown clayey silt deposit
525		526	Ditch cut	Linear ditch, steep sided, concave base
526	525		Ditch fill	Brown clayey silt deposit
527		528,541	Ditch cut	Linear ditch, steep sided, concave base
528	527		Ditch fill	Grey-brown sandy silt deposit
529		530	Pit cut	Circular, steep sided, concave base
530	529		Pit fill	Pale brown sandy silt deposit
531		532, 533	Pit cut	Sub-rectangular, steep sided, concave base
532	531		Pit fill	Brown sandy silt deposit
533	531		Pit fill	Yellowish brown silty sand deposit
534		535	Ditch cut	Linear ditch, shallow sided, sloping base
535	534		Ditch fill	Yellowish brown clayey silt deposit
536			Layer	Subsoil
537			Layer	Topsoil
538			Layer	Re-deposited chalk
539		540	Ditch cut	Linear ditch, steep sided, concave base
540	539		Ditch fill	Light olive brown clayey silt deposit
541	531		Pit fill	Yellowish brown sandy silt deposit
542		543	Ditch cut	Linear ditch, steep sided, concave base
543	542		Ditch fill	Brown sandy silt deposit
544		545	Pit cut	Circular, shallow sided, concave base
545	544		Pit fill	Light olive brown clayey silt deposit
546		547	Ditch cut	Linear ditch, steep sided, concave base
547	546		Ditch fill	Yellowish brown clayey silt deposit
548		549,550,551, 552,553, 554	Pit cut	Square, steep sided, flat base
549	548		Pit fill	Olive brown sandy silt deposit
550	548		Pit fill	Olive brown sandy silt deposit
551	548		Pit fill	Light olive brown sandy silt deposit
552	548		Pit fill	Re-deposited chalk
553	548		Pit fill	Olive brown clayey silt deposit
554	548		Pit fill	Re-deposited brick
555	556		Fill	Sharp sand
556		555	Machine cut	Construction cut for car park
557	559		Pit fill	Olive brown clayey silt deposit
558	559		Pit fill	Re-deposited chalk (capping)
559		557, 558	Pit cut	Sub-circular, steep sides (slightly under cut, concave base)
560			Wall course	Small area of brick construction associated to wall 500
561			Layer	Hammered chalk creating a level surface associated to wall 500
562			Layer	Greyish brown silty clay deposit
563				Not used
564			Wall course	Clunch foundation associated to wall 500
565			Wall course	Clunch foundation associated to wall 500
566			Wall course	Clunch foundation associated to wall 500
567			Wall course	Clunch foundation associated to wall 500
568		566	Foundation cut	Excavated segment of wall 500
569		567	Foundation	Excavated segment of wall 500

<b>Context No</b>	<b>Fill of</b>	<b>Filled by</b>	<b>Context type</b>	<b>Description</b>
570		571	Posthole cut	Circular, steep sided, flat base
571	570		Posthole fill	Dark greyish brown clayey silty deposit
572		573	Posthole cut	Circular, steep sided, flat base
573	572		Posthole fill	Dark grey clayey silt deposit
574		575,576	Posthole cut	Rectangular, steep sided, flat base
575	574		Posthole fill	White re-deposited chalk (packing)
576	574		Posthole fill	Olive brown clayey silt deposited
577				Not used
578				Not used
579		580	Posthole cut	Circular, steep sided, flat base
580	579		Posthole fill	Dark grey clayey silt deposit with flecks of charcoal
581		582	Posthole cut	Circular, steep sided, flat base
582	581		Posthole fill	Greyish brown clayey silt deposit

*Appendix 10: Site Photographs, Open Day and Newspaper Coverage*



*Plate 1* General view of FOXHS02 under excavation



*Plate 2* Survey work on FOXHS02



*Plate 3* Section of Pit 559



*Plate 4* Gallo-Belgic vessel found during FOXHSA99 excavations

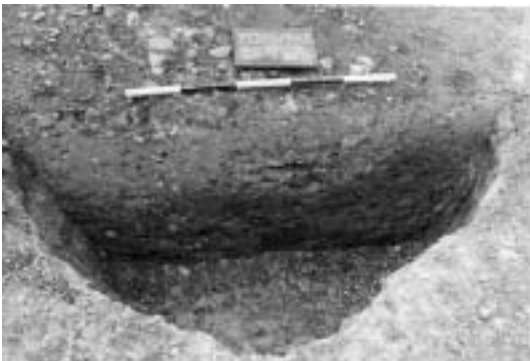

*Plate 5* Section of Pit 548



*Plate 6* Open Day



*Plate 7* Open Day

## Dig reveals ancient villagers were well off



# A wealth of finds

**TREASURES** from the past, plus hundreds of pieces of broken pottery, have been dug up in Foxton. Archaeologists have combed through tonnes of soil to find out more about the people who lived in the village centuries ago. Reporter **KATE ASH** persuaded them to show tools and reveal their finds.

**CLUTCHING** a 2,000-year-old vase I suddenly find my fingers trembling. "Hold on hard on the bottom, like a baby," advises Mark Hissman of the Archaeology Field Unit.

It is a beautiful object. Made in the late Iron Age, between 20-40 AD, its pattern is almost as clear as the day it was cast.

Its discovery at the site, just off Foxton High Street, caused a stir and revealed that the ancient villagers were relatively well-to-do.

It was found as a cremation urn and was imported from France, just before the Romans invaded in 43 AD.

The person whose remains were to rest inside was probably a rich farmer or member of the Iron Age elite, according to Mr Hissman, senior project officer.

He said: "It is extremely elegant and it wouldn't have been cheap.

"Finding imported goods, which were relatively expensive, shows that there was a cultured elite living in south west Cambridgeshire.

"It was a fairly muddy area, just like today." Builders are due to move onto the site, which has been earmarked for new housing, so the clock is ticking for the dig.

However, the archaeologists believe they have already unearthed everything of interest, thanks partly to the hard work of volunteers such as Dudley Pacey.

Mr Pacey, 51, who lives in Foxton and has been involved with searching and digging the site, said: "Finding something that no-one has touched for centuries is a real excitement.

Unearthing the past... archaeologists at work just off Foxton High Street, top left, with inset, some of the objects discovered. Above, an Iron Age pot found at the site.

"I've always been interested in archaeology and I couldn't resist getting involved when they started digging in my village."

The dig has shown that people have lived in Foxton for thousands of years, as first work from 2,800 BC has been discovered.

Recent finds include a chalk well, dating back to the 17th Century, which was the former site of archaeologist Bob Hatten.

He said: "It is rare because chalk usually decays. We think it is on the same alignment as the next door cottage as it would have been a boundary wall."

Fragments of Roman pots were also dug up by archaeologist Nick Pate. He said: "You could still see the pattern and make out the flange parts, about the same size as mine."

However, it is feared that much of the archaeology was destroyed in the 1930s when foundations were dug for a community centre, which used to stand at the site. This could explain why expected finds from the early Saxon period failed to materialise.

Children from Foxton School visited the dig earlier this week to see the fragments from the past. Mr Hissman said: "We want to encourage young people to be interested in archaeology.

"It is a privilege. We uncover things which no one has seen, sometimes for thousands of years."

To find out more about open days at archaeological digs around the county, visit Cambridgeshire County Council's website at [www.cambridgeshire.gov.uk](http://www.cambridgeshire.gov.uk)



**Easy does it...** Project manager Mark Hissman, left, gingerly scoops away at the earth looking for more finds as does a willing pair of hands, right.



Plate 8 Press coverage of the FOXHS02 Open Day (Article by Kate Ash and reproduced by kind permission of the Cambridge Evening News)



Cambridgeshire  
County Council

Education, Libraries  
and Heritage

*The Archaeological Field Unit  
Fulbourn Community Centre  
Haggis Gap  
Fulbourn  
Cambridge CB1 5HD  
Tel (01223) 881614  
Fax (01223) 880946*