

2005-2006



Protocol for reporting finds of archaeological interest

Annual Report to BMAPA 2005-2006



ENGLISH HERITAGE



November 2006

Prepared by

Wessex Archaeology 

British Marine Aggregates Producers Association and English Heritage

Protocol for reporting finds of archaeological interest

Annual Report to BMAPA 2005-2006

November 2006

prepared by
Wessex Archaeology

Project Background

In April 2003, the British Marine Aggregates Producers Association (BMAPA) and English Heritage (EH) jointly published *Marine Aggregate Dredging and the Historic Environment: Guidance Note*. The Guidance Note sets out the character and importance of the marine historic environment and describes best practice in dealing with archaeological matters in the course of planning marine aggregate dredging in English marine waters. It includes details of measures to mitigate the effect of marine aggregate dredging on the historic environment, including the implementation of protocols to report and deal with finds made in the course of dredging.

Protocols for reporting archaeological finds emerged as a mitigation option as it became apparent that watching-briefs by archaeologists, either on board dredging vessels or at wharves, were likely to prove ineffective because of the scale and character of the dredging process. Protocols are intended to provide a 'safety net' for reporting finds that occur once dredging is in progress, and are in addition to measures to avoid areas of archaeological sensitivity through desk-based assessment and field evaluation.

Such protocols have formed part of the mitigation strategy set out in several Environmental Statements for individual

dredging licence applications. However, BMAPA recognised that it would be more consistent and effective to introduce a single, unifying protocol and in August 2005 BMAPA and EH introduced a protocol applicable to all BMAPA members, covering all wharves, vessels and production licence areas.

The Protocol was prepared by Wessex Archaeology (WA) in consultation with BMAPA, EH and other interested parties. BMAPA member companies have voluntarily committed to implementing the Protocol across all existing operations. It is hoped that non-BMAPA companies will also adopt the Protocol voluntarily.

Protocol

The Protocol provides for finds being made by members of staff employed by aggregate dredging companies on the seabed, on board dredging vessels, and at wharves.

Under the Protocol, staff report to a local 'Site Champion' on the vessel or at the wharf and the Site Champion compiles a preliminary report. The Site Champion passes the report on to the 'Nominated Contact', a single identified person within each company (see table overleaf).

The role of the Nominated Contact within each company is to inform EH of the find as soon as

possible, and to pass on the reported details, preferably within two working days of receiving information from the Site Champion. The Nominated Contact is also required to advise other dredgers operating in the same area to keep a particular watch for finds and, if the seabed position of the find is reasonably certain, to implement a Temporary Exclusion Zone (TEZ) until archaeological advice has been obtained. TEZs may only be revoked if it can be concluded that no important wreck or other feature is present. TEZs may be formalised as a longer-term Archaeological Exclusion Zone (AEZ) if the presence of a wreck or feature is confirmed or if no conclusion can be drawn and the company does not wish to resolve the situation by further investigation.

EH's role is, on receiving the report, to advise the Nominated Contact of the actions to be taken. EH will also liaise with various agencies, institutions and individuals with responsibilities and interests in respect of the marine historic environment and finds from the sea, and pass details of the find on to the National Monuments Record (NMR) and appropriate local Sites and Monuments Record/Historic Environment Record (SMR/HER).

WA is currently carrying out aspects of EH's role as part of an Implementation Service commissioned and supported by BMAPA.

BMAPA Company	Nominated Contact	Position
Britannia Aggregates Ltd	Richard Fifield	Marine Resources Manager
DEME Building Materials Ltd	Frank Rimell	Resident Manager
Hanson Aggregates Marine Ltd	Robert Langman	Resources Manager
Kendall Bros (Portsmouth) Ltd	Richard Kendall	
Northwood (Fareham) Ltd (Lafarge Aggregates Ltd)	Brian White (Malcolm Whittle)	General Manager
Norwest Sand & Ballast Ltd	Nick Brown	General Manager
CEMEX UK Marine	Graham Singleton	Marine Resource Manager
United Marine Aggregates Ltd	Andrew Bellamy	Resources Manager
Volker Dredging Ltd	Richard Fifield	Marine Resources Manager

Implementation Service

The Implementation Service encompasses elements of EH's role in the Protocol that are concerned with recording and passing on information about reported finds, and limited decision-making regarding archaeological actions in respect of reports that can clearly be addressed without contention.

The Implementation Service does not cover decision-making where a higher level of curatorial involvement is required (i.e. where reports result in TEZs that are likely to warrant further investigation and/or formalisation as an AEZ).

At the core of the Implementation Service is a web-based reporting system. Nominated Contacts have secure access to web pages on which they can record details of finds reported by Site Champions and through which they can receive advice.

Each report received through the web-pages is assessed by WA staff. Contentious discoveries are forwarded promptly to EH for further curatorial assessment. Reports considered non-contentious are dealt with by WA staff.

Scanned drawings, digital photographs and other files may be uploaded to the website for the purposes of interpretation. In certain circumstances WA may request that the find is made available for closer inspection but, in most cases, recovered finds are held by the companies.

Advice is sought from accredited specialists within and external to WA regarding both interpretation and any additional works required to stabilise, conserve or record recovered finds. This advice is passed to the Nominated Contacts along with guidance on resolving issues of ownership and disposing of finds.

The provision to carry out any additional work falls outside the terms of the Implementation Service although the companies may make arrangements with WA to carry out further work at an additional cost. Advice on sources of funding can be provided by WA.

WA is also responsible for disseminating the information reported through the Implementation Service to the NMR and local SMR/HER and other interested parties such as:

- EH Maritime Team;
- The Crown Estate;
- EH regional offices;
- Local Government Archaeological Officers;
- Portable Antiquities Scheme (PAS) Finds Liaison Officers;
- the Receiver of Wreck;
- the Ministry of Defence.

Through the web pages WA can generate a report compliant with the Monument Inventory Data Standard, a content standard for heritage data sets that sets out what sort of information should be recorded. This report can then be forwarded via email to the above parties.

Feedback is sent to the wharves and vessels in the form of an A4 poster providing an archaeological and historical context for the discovery and outlining its importance.

If permission is given by the Nominated Contact details of the finds are also made publicly available through WA's web pages.

Further information about the Protocol and the Implementation Service may be found at:

- <http://www.wessexarch.co.uk/projects/marine/bmapa>



Awareness programme poster and training

Raising Awareness

During 2006 WA undertook a programme of education and awareness raising to accompany the introduction of the Protocol. The Awareness Programme was funded through the Aggregates Levy Sustainability Fund (ALSF) and comprised:

- visits to BMAPA company wharves and vessels;
- visits to benthic and geophysical survey companies;
- workshops for Nominated Contacts, Site Champions and other interested parties including archaeology professionals;
- the development of a DVD-based remote training package for BMAPA company vessels.

Visits were undertaken to 30 wharves, 3 vessels and 4 survey companies and made use of a combination of formal and informal techniques, including presentations, group discussions and one-to-one discussion as appropriate to circumstances and facilities.

Specific information was provided to staff on:

- the nature of the marine historic environment;
- identifying typical marine finds;
- the responsibilities of staff under the Protocol;
- handling and storing marine finds;
- basic finds recording.

Difficulties with arranging suitable times to visit most vessels - primarily relating to tight shipping schedules - and to some wharves resulted in the production of a DVD-based remote training package which was sent out to all those wharves and vessels WA were unable to visit.

Three regional workshops were organised focusing on finds recognition, handling, recording and storage. Particular emphasis was

placed on the questions commonly raised by aggregate company staff.

The first was held in Salisbury in April 2006 and focused on marine aggregate dredging operations in the West and South West. The second was held in York in July 2006 and focused on dredging in the North and the third was held in London in October 2006, focusing on dredging in the East and South East.

The workshops demonstrated the importance of finds reported from industry, and the contribution such reports are making to our understanding of the past. The workshops also provided an opportunity for discussion and the exchange of experience and views.

During the course of the Awareness Programme WA took part in a number of seminars, meetings and outreach events to introduce the Protocol to a wider audience and to illustrate the importance of the artefacts reported through the Protocol. These included:

- EH Outreach Seminar (Savile Row, London 14/02/06);
- PAS AGM (British Museum, London 16/03/06)
- EH ALSF Seminar (Savile Row, London, 12/05/06);
- Stourhead Archaeology Extravaganza (Nautical Archaeology Society, Stourhead, Wiltshire, 03/06/06-04/06/06);
- Maritime Archaeology and Wildlife Weekend (Hampshire and Wight Trust for Maritime Archaeology, Hurst Castle, Hampshire, 19/08/06-20/08/06) (Figure 5);
- Marine ALSF Conference (University of Southampton, 08/09/2006);

WA also submitted an article to Dredging and Port Construction magazine which has an international readership throughout all sectors of the industry.



Selection of pre-Protocol finds

Reports: Pre-Protocol

Prior to the establishment of the Implementation Service a number of finds were brought to the attention of WA:

- Fishing net weight (CEMEX, July 1999);
- mammoth tooth, tusk, vertebra, scapula and red deer antler (UMA, August 2002);
- giant deer jaw (UMA, April 2003);
- gun and holster (UMA, April 2004);
- mammoth tooth (UMA, December 2004);
- cannonball and two iron pins (UMA, February 2005);
- explosive harpoons (Hanson, May/October 2005);
- Cannonball (Hanson, November 2005);

During the course of the Awareness Programme further finds were brought to the attention of WA that, for a variety of reasons, were not reported through the Implementation Service:

- aircraft remains, identified as a Supermarine Attacker (Hanson, Arco Dart, February 2006);
- wooden practice shell (UMA, April 2006);
- chrinoidea fossils (CEMEX, Billingham, May 2006);

- pewter plate (Hanson, Wallsend on Tyne May 2006);
- possible cannonball (UMA, Newhaven, May 2006);
- mammoth tooth (UMA, Erith, June 2006);
- anchor (UMA, Erith, June 2006);
- building stone (UMA, Erith, June 2006);
- fishing net weight (UMA, Ridham, June 2006);
- fragment of timber with copper nail (Britannia, Northfleet, September 2006);
- unidentified, bowl shaped iron artefact (Britannia, Northfleet, September 2006);
- selection of animal remains including mammoth teeth and tusks (Britannia, Northfleet, September 2006).

Many of these discoveries were found before the Protocol had been implemented and in most cases key details such as location of discovery had not been recorded. Most had been kept at the wharves or on board vessels for a substantial length of time.

A record of these discoveries has been kept in the project archive.



Seafang

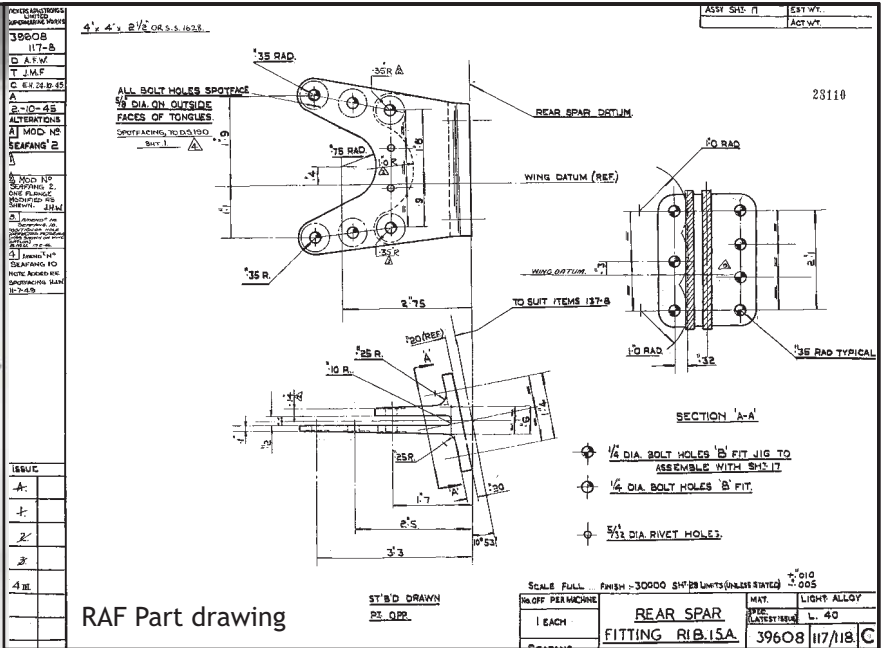

RAF Part drawing



Spitfire



Attacker

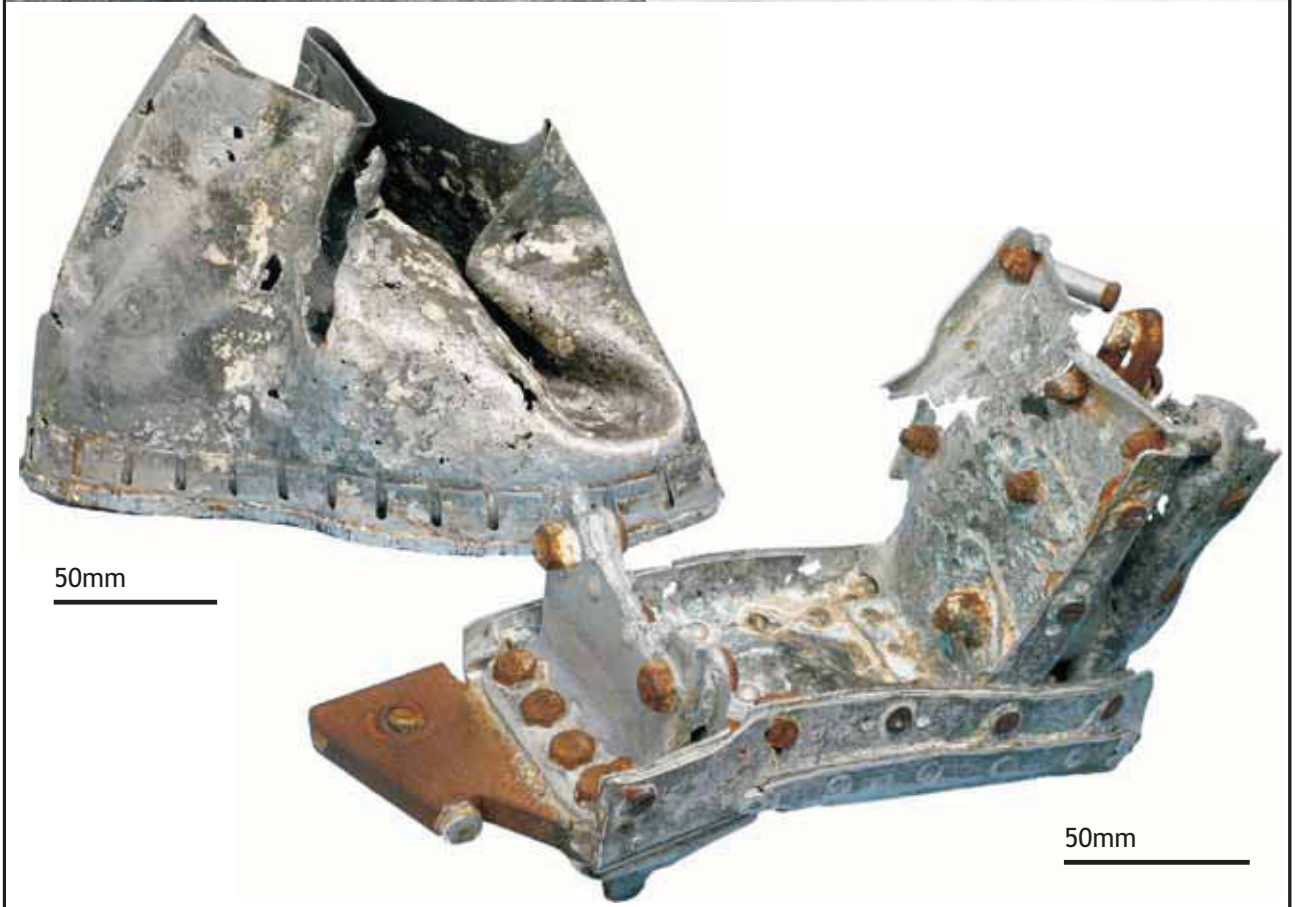

Case study - Supermarine Attacker

Case Study: Supermarine Attacker

In 2005 two pieces of aircraft wreckage were spotted on board the Hanson Aggregates Marine dredger 'Arco Dart' within sand and gravel dredged off the coast of Worthing, Sussex. The parts were kept on board the vessel for over a year before being passed to WA staff during a site visit as part of the Awareness Programme.

The RAF museum at Duxford was able to match a serial number identified on one of the two parts to a rear wing spar from a plane developed by Supermarine at the end of the Second World War, the Spiteful, an intended replacement for the Spitfire. However, very few of this type of plane were manufactured after the design was rejected by the RAF in favour of the new jet powered Gloster Meteor and de Havilland Vampire.

Supermarine's first attempt at a jet powered fighter, the Attacker, kept the same wing as the Spiteful and, although the design was rejected by the RAF, 143 were built for the Royal Navy. The Attacker entered service as the first jet fighter of the Fleet Air Arm and several were lost at sea.

The most likely match for the parts found on the Arco Dart is the Attacker WP275 which crashed into the sea on the 6th July 1956 after taking off from Royal Naval Air Station Ford, in Sussex when the wing tip folded and the pilot ejected. The pilot, Sub-Lieutenant J. F. Yeates of the Royal Naval Volunteer Reserve, survived unharmed.

Crashed aircraft are important to archaeologists because in many cases they offer a unique form of evidence for the historic development of flight. If surviving examples of a particular type of craft do exist they are often only the later models of a particular type or they have been heavily refurbished. Moreover, all crashed military aircraft are protected by law under the Protection of Military Remains Act 1986. The discovery of aircraft remains is thus incredibly important, particularly as aircraft crash sites may contain human remains.



Selection of finds reported through the Protocol during 2005-2006

Reports: Protocol

During the first year of operation WA received 19 reports through the Implementation Service encompassing over 80 separate finds (see table below).

None of the reports were considered contentious by WA and no higher level curatorial involvement from EH was required.

Further details of each discovery are included in the wharf reports appended to this report.

Date Reported	Report ID	Description	No. of Finds
12/10/2005	Hanson_0008	Cannonball, whale bone and block wheel	3
31/10/2005	CEMEX_0015	Two pieces of metal and a bone	3
02/12/2005	Hanson_0018	Mammoth bones and teeth and a piece of deer bone	10
10/01/2006	Hanson_0019	Bomb	1
01/02/2006	UMD_0021	Mammoth humerus	1
01/02/2006	UMD_0022	Rowlock, fishing weight and ornamental object	3
07/02/2006	UMD_0026	Boat hook	1
01/03/2006	Hanson_0035	Mammoth tusk	1
03/05/2006	CEMEX_0039	Eroding peat layer with animal bone, wood and a struck flint	Multiple (20+)
31/05/2006	UMD_0041	Fragment of bone, possible deer metatarsus	1
31/05/2006	UMD_0042	Fragments of bone, possible pelvis of a horse, scapula, rib and long bone from horse, cattle or deer	4
31/05/2006	UMD_0043	Fragment of tooth, possible woolly mammoth	1
31/05/2006	UMD_0044	Fragments of bone, possible pelvis and long bone from horse, cattle or deer	2
31/05/2006	UMD_0045	Half of an upper molar of a woolly mammoth	1
21/07/2006	UMD_0059	Aircraft remains	3
26/07/2006	UMD_0061	Aircraft remains	Multiple (20+)
11/08/2006	UMD_0062	Aircraft brake pedal and lamp	2
25/08/2006	CEMEX_0064	Cannonball	1
04/09/2006	UMD_0065	Fishing net weights	2
			80+



50mm



50mm



Staff from Purfleet Aggregates

Case study - Mammoth Tusk

Case Study: Mammoth Tusk

In February 2006 a mammoth tusk fell off the conveyor belt, just as it was about to enter the crusher, at Purfleet Aggregates Ltd., Thurrock, Essex. The load had been dredged from the Coal Pit, Hanson's license area 408, c. 50 miles North East of the Wash.

Mammoths are relatively rare fossils in Britain and there are few dated examples. They occur from the Wolstonian ice age (380,000 to 130,000 years ago) to the end of the Devensian ice age (c. 10,000 years ago). The nearest dated examples to area 408 are found in the Southern Bight of the North Sea, 120km to the south-east, where radiocarbon dates for thirteen *Mammuthus primigenius* fossils all date between 32,000 and 40,000 years old (van Glimmerveen et al. 2004).

The tusk from Area 408 is one of the most northerly examples of *Mammuthus primigenius* for which good positional data is available and may have significant implications for understanding of the distribution of this species during the last ice age.

The tusk is not an articulated element; it was recovered from gravel and was therefore not *in situ*. However, the level of reworking is believed to be moderate in these gravels (Allen 2006). The tusk is in good condition with some discolouration and flaking, and damaged at the tip and the proximal part, some of which may have occurred during the process of being dredged. It was unlikely to have been residual for more than 5,000 years and as such may be assumed to be approximately coeval with the deposit. Thus, dating the tusk will also broadly provide a date for the gravel deposit.

Samples from the tusk were submitted by English Heritage's Scientific Dating section for AMS dating at the Oxford Radiocarbon Accelerator Unit, University of Oxford, and the Centre for Isotope Research at the University of Groningen (Allen 2006).

Two results have so far been received:

OxA-16326	44450±650BP
GrN-30233	43150±1500BP

A further sample is being dated for quality-control purposes and the result is expected in early December 2006 (Allen 2006). Once this result has been received the archaeological significance of the discovery will be fully assessed. However, the precision of this result exceeds those of most other previous results and is a significant scientific and archaeological advance.

This result is an important addition to the compendium of Mammoth dates, has confirmed the date of the gravels and highlights the value of the Protocol.

References

Allen, M., 2006, Area 408 Zone C: Swart Bank: Interim Radiocarbon Results, Interim Report, Wessex Archaeology.

Glimmerveen, J. van, Mol, D., Post, K., Reumer, J.W.F., Plicht, H. van der, Vos, J. de, Geel, B. van, Reenen, G. van and Pals, J.P., 2004, The North Sea project: the first palaeontological, palynological and archaeological results. In: N.C.Fleming (ed.), *Submarine prehistoric archaeology of the North Sea*, CBA Research Report 141, 43-52.

Specialists

During the year 2005 to 2006 specialist advice was sought from a number of experts in order to obtain the best possible interpretation and to offer the most appropriate advice to Nominated Contacts regarding conservation and disposal of the finds.

A number of specialists also spoke at the workshops organised as part of the Awareness Programme.

Further details of the contribution made by specialists are included in the wharf reports appended to this report.

Expert	Specialism	Institution/Organisation
Andy Curren	Ice age mammals	Collections Manager (Palaeontology), Natural History Museum
Andy Simpson	Military aircraft	Curator, Aircraft and Exhibits Department, RAF Museum
Antony Firth	Commercial maritime archaeology	Section Head (Coastal and Marine), Wessex Archaeology
Cathie Chisham	Sediments and palaeobotany	Environmental Archaeologist, Wessex Archaeology
Graham Scott	Ship archaeology and underwater fieldwork	Senior Archaeologist (Coastal and Marine), Wessex Archaeology
Gustav Milne	London Archaeology and Maritime Archaeology	Senior Lecturer, University College London
Ian Panter	Conservation of marine finds	Principal Conservator, York Archaeological Trust
Jack Russell	Environmental archaeology	Archaeologist (Coastal and Marine), Wessex Archaeology
Jenni Chambers	Prehistoric flint	Project Officer, National Ice Age Network
Jens Auer	Ship archaeology, submerged aircraft remains and underwater fieldwork	Senior Archaeologist (Coastal and Marine), Wessex Archaeology
Jessica Grimm	Animal bone	Animal Bone Specialist, Wessex Archaeology
Lorraine Mephram	Finds specialist, ceramics	Finds & Archives Manager, Wessex Archaeology
Matt Leivers	Prehistoric flint	Finds Specialist, Wessex Archaeology
Mike Trevarthan	Prehistoric flint	Project Officer, Wessex Archaeology
Richard Sabin	Cetacean remains	Curator, Mammal Curation Group, Natural History Museum
Stuart Leather	Submerged Prehistoric Landscapes	Project Manager, Wessex Archaeology
Vince Holyoak	Military aircraft	Senior Policy Officer, Rural & Environmental, English Heritage

Liaison and Accessibility

Details of each discovery have been sent to:

- Virginia Dellino-Musgrave, EH Maritime Team;
- Mark Russell, BMAPA;
- Mike Cowling, The Crown Estate;
- David Hilton, NMR.

Details of discoveries regarded as wreck under the Merchant Shipping Act 1995 have been forwarded to the Receiver of Wreck:

- Hanson_0008
- CEMEX_0015
- UMD_0022
- UMD_0026
- UMD_0059
- UMD_0061
- UMD_0062
- CEMEX_0064

- UMD_0065

Details of discoveries that may relate to military wrecks or aircraft have been forwarded to the Ministry of Defence:

- Pre-protocol: Supermarine Attacker;
- UMD_0059
- UMD_0061
- UMD_0062

Data has also been sent to the appropriate PAS Finds Liaison Officers and to the Local Government Archaeology Officers and SMR/HER in the county off which the discovery was made.

Further details of liaison and the return of data to interested parties are included in the wharf reports appended to this report.

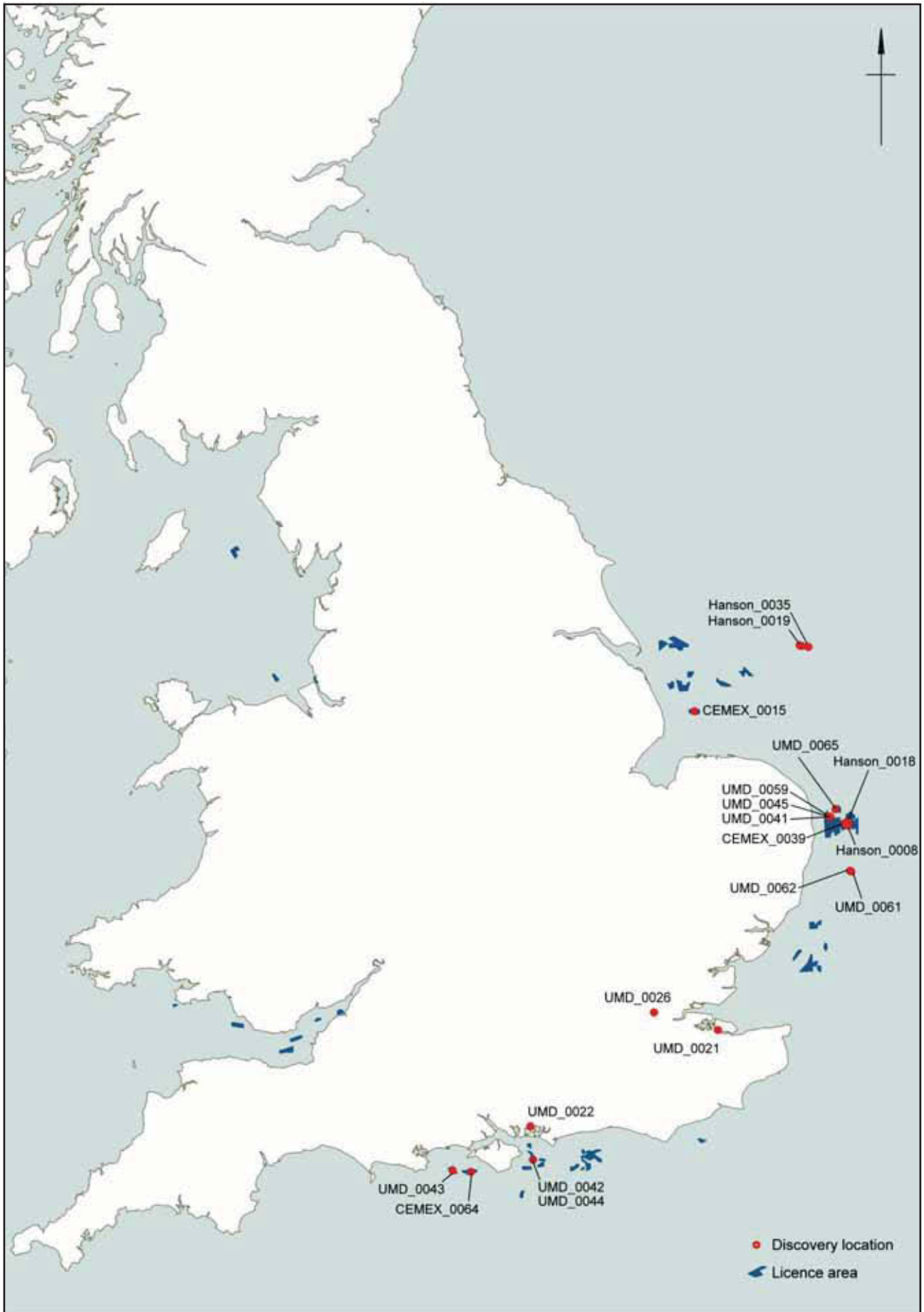

Location of discoveries 2005-2006

Discussion

Importance

During the year 2005-2006 over 80 separate artefacts have been reported through the Implementation Service. A number of 'pre-Protocol' finds have also been brought to the attention of WA staff during visits to wharves as part of the ALSF funded Awareness Programme.

A number of these discoveries have proved extremely important in their own right. For example, the identification of the Supermarine Attacker WP275, the dating of mammoth tusk Hanson_0008 and the identification of an eroding peat layer CEMEX_0039. The individual importance of each discovery is discussed in further detail in the wharf reports appended to this report.

All discoveries, however, will ultimately contribute to a fuller understanding of the marine historic environment and the distribution of archaeological remains on the seabed, as well as meeting best practice and discharging licence conditions and other legal obligations.

The map opposite shows the distribution of the finds so far reported through the Implementation Service. As further discoveries are reported and mapped it will be possible to identify meaningful patterns in the distribution of types of finds that will aid archaeologists in the identification of sites and archaeologically sensitive areas on the seabed.

In disseminating the data reported through the Implementation Service the aggregates industry is directly contributing to the baseline information on submerged archaeology accessible in the NMR and SMRs/HERs. Moreover, the Protocol is also contributing to an understanding of the marine historic environment throughout the wider archaeology profession.

This is of benefit to both the public in general and to the marine aggregate industry in enabling companies and curators to be quickly alerted to the presence of archaeological sites that can be better protected as a result.

Key Issues

During the past year a number of issues have been raised that WA have begun to address to improve the efficiency of the Implementation Service.

Metal/Concreted Finds

The use of a magnet and metal detectors at most wharves means that a substantial number of potentially interesting metal artefacts are discovered in most loads. This has brought into question the viability of reporting every discovery through the Implementation Service.

Wharves and vessels have been advised to report all items produced from metals other than iron and steel. Aluminium objects may indicate aircraft wreckage, copper and copper alloy objects might indicate a wreck or may be very old and precious metal objects and coins are relatively easy to date and are thus of high archaeological value.

However, where non-ferrous items are obviously of recent date and/or made of thin, tinned or painted metal sheet it will not be necessary to report them.

The Protocol recognises that the range and date of iron and steel objects is so wide that it is difficult to provide general guidance. It recommends that objects covered in concretion are likely to be of archaeological interest as the thick amorphous concrete-like coating indicates that the object has been submerged for some time. The Protocol also suggests that pieces of metal sheet and structure may indicate a wreck and should be reported.

This advice, however, has proved to be insufficient to account for the iron, steel and concreted objects recovered through the magnet and metal detector.

Of the 80+ finds reported through the Implementation Service only six ferrous items have been reported including four easily recognisable objects (two cannonballs, an ornamental object and a boat hook) and two items of possible ship structure. The rest of the items comprise objects of wood, bone and non-ferrous metals. Far more ferrous items are

discovered at the wharves, however, than any other material.

This discrepancy indicates that confusion surrounding what should and should not be reported is resulting in a failure to report the ferrous items.

At present wharves have been advised to report all ferrous artefacts that are either unusual or readily identifiable as part of a ships equipment.

Alternative approaches have been discussed including stockpiling metal artefacts for regular examination by an archaeologist and stockpiling concretions for x-ray.

During the coming months the precise nature of the recovery of metallic items at wharves will be fully investigated and clear guidance will be produced so that objects of archaeological value can be readily identified.

Receiver of Wreck

The high number of metal and concreted finds is additionally complicated by the legal requirement to report all items of wreck to the Receiver of Wreck under the Merchant Shipping Act 1995. Each piece of metal may prove to originate from a wreck and, as such, should be reported. In practice, however, neither the wharf staff nor the Receiver of Wreck are in a position to deal with such large numbers of finds.

Following discussions with the Receiver of Wreck, WA has incorporated the requirement to report finds within the Implementation Service and a function has been created within the web-based reporting system to automatically generate a report which can be sent to the Receiver. This will enable professional archaeologists to offer appropriate advice on which finds need to be reported to the Receiver and reduce the paperwork that needs to be completed by wharf staff and the Receiver.

The applicability of this process is currently being assessed and the issue is expected to be resolved in the near future.

The Portable Antiquities Scheme: Finds Liaison Officers

The Protocol states that, in addition to a number of other individuals and institutions, EH are required to liaise with the relevant PAS

Finds Liaison Officer with regard to each individual discovery.

The PAS is a voluntary scheme to record archaeological objects found by members of the public in England and Wales. The scheme was established to promote the recording of chance finds and broaden public awareness of the importance of such objects for understanding our past.

At the heart of the PAS is its network of Finds Liaison Officers, who have a role in publishing the scheme, recording reported finds, giving advice on finds recording and conservation, giving talks and lectures and encouraging liaison between members of the public, metal detector users, archaeologists and museums.

Initially WA simply forwarded details of each discovery - to the officer in the county off which the discovery was made - as part of the Implementation Service.

However, following discussions with the PAS it has been decided that the most valuable role that the Finds Liaison Officers could play would be in providing local information for wharves and, where discoveries are made on board vessels, the dredging companies. As such, details of discoveries are now being sent to the officer for the county in which the wharf or company is based.

In particular, it is hoped that through the PAS the dredging companies will be able to forge links with local institutions that may be able to assist with conservation or act as a repository for important finds.

Munitions

A Guidance Note has been produced by the industry in conjunction with the police and Health and Safety Executive which sets out the appropriate procedures to be taken should a munition be encountered either on board a dredger or at an aggregate wharf. This takes precedence over any archaeological requirements. Discoveries of munitions may also be of archaeological interest and the Protocol requests that they should be reported.

It has become clear that some wharves and vessels will encounter munitions on a regular basis, some as often as two or three times a week. During the year 2005-2006, however,

only two cannonballs and one bomb have been reported through the Protocol.

When items are discovered, the procedures defined in the Guidance Note require munitions experts to identify and to decommission or dispose of the item where necessary and, in most cases, a record of each instance will be kept for future reference.

It has been recognised that, due to the high numbers of items being encountered, filing an additional report through the Implementation Service would create an unrealistic amount of extra paperwork for the Site Champions.

It may be beneficial to develop a separate reporting system for munitions to enable wharf managers and vessel masters to simply forward a copy of the records they are required to keep as part of their standard procedures. In this way munitions which may prove of archaeological interest can be identified through the Implementation Service.

Additional guidance will be developed to resolve this issue during the coming months.

Encouraging Smaller Companies

During the first year of the Protocol reports were submitted by only three of the nine BMAPA companies, UMA, Hanson and CEMEX.

These are the three largest of the BMAPA companies with the greatest number of wharves and vessels processing the greatest volume of aggregate. It is possible, therefore, that the lack of reports from smaller companies may be a direct reflection of the amount of aggregate processed.

It may also be a reflection, however, of other operational circumstances which constrain the discovery of artefacts or the filing of reports.

For example, during the course of the Awareness Programme WA became aware that a vessel dredging for sand alone will process the aggregate at sea and that all aggregate larger than sand, including archaeological artefacts, will be redeposited straight over the side of the vessel. While it is possible that anomalies on the seabed or artefacts trapped in machinery will be identified at sea, the aggregate offloaded at wharves is unlikely to contain artefacts of archaeological interest. This is particularly the case for operations

which take place in the North West and Bristol Channel regions

Where the existence of operational constraints can be identified wharves may benefit from the development of additional guidance and assistance with regard to the application of the Protocol. However, where no such circumstances can be identified smaller companies may simply need further encouragement to report discoveries through the Implementation Service.

Third Parties (Wharves and Survey Companies)

Related to the above issue is the use of third parties by BMAPA companies and the extent to which they should also be encouraged to adhere to the Protocol.

Many marine aggregate wharves are not in fact operated by BMAPA member companies. While BMAPA members have encouraged all wharves where marine aggregates are supplied to participate (including several which are located on the Continent), they are under no obligation to report discoveries under the terms of the Protocol.

The extension of the Protocol to cover all work done for BMAPA members by survey or geotechnical companies has been discussed with BMAPA. However, in the coming months efforts will be made to agree the extent to which all contractors may be bound by the terms of the Protocol.

Delay in Reporting and Responding

During the year 2005-2006, WA has noted a significant delay in many instances between the discovery of an artefact, the compilation of a preliminary report by the Site Champion and the filing of an online report by the Nominated Contact. In some cases WA also recognise that there has been a similar delay in providing a formal response to the Nominated Contact although in most instances an informal response has been offered as soon as possible.

The Protocol requires certain actions to be undertaken by the various parties. The timescale of many of these actions may be critical to safeguarding finds of archaeological interest and to avoiding unreasonable disruption to commercial operations.

The Protocol recommends that staff should report a find to the Site Champion immediately

so that the position of the find or anomaly on the seabed may be calculated and so that measures may be taken to safeguard finds. The Site Champion should forward a preliminary report to the Nominated Contact on the same day so that decisions with operational implications, such as the establishment of TEZs, can be made promptly. The Nominated Contact is expected to file a report through the Implementation Service within two working days of receiving the information from the Site Champion.

In order to minimise any impact on operations the Protocol also recommends that an initial formal response from WA should be made to the Nominated Contact within two working days of receiving the information.

During 2005-2006 no reports were considered contentious by WA, no higher level curatorial involvement from EH was required and no TEZs were required. The time delay has not, therefore, proved problematic. However, this may not necessarily continue to be the case and efforts must be made by all parties to adhere to the recommended overall timescale of five working days for the reporting process.

Feedback: Newsletter

The importance of providing feedback to wharves has been recognised, both to encourage staff and to highlight the importance of the contribution made by the marine aggregates industry.

Wharf reports (appended to this report) have been produced to send to the wharf or vessel at which a discovery was made. In addition, details of discoveries have been posted on the WA website:

- <http://www.wessexarch.co.uk/projects/marine/bmapa/discoveries.php>

However, it has been suggested to WA that these measures are insufficient. Webpages cannot be relied upon as a means of publicising the finds being made because many staff do not have access to the internet. The wharf reports are also insufficient to publicise the discoveries across the marine aggregates industry as, to date, they have been sent only to those who made the discovery. Finally, in most cases, the paper reports and webpages have only been produced once research for each discovery has been completed, which may

mean a significant delay if, for example, it is necessary to wait for lab results or specialist advice.

Some wharf staff have requested regular updates of the finds being reported through the Implementation Service to maintain interest and to facilitate a deeper understanding of what is and is not considered archaeologically important. A printed newsletter appears to be the preferred option and WA are currently discussing options with EH and BMAPA.

Conservation and Disposal of Finds

Perhaps the most important issue that has been raised over the past year is the lack of clear guidance on what should happen to finds once they have been reported or who should be responsible for longer term conservation and storage.

The role of PAS Finds Liaison Officers in providing advice on what to do with finds in the long term has been discussed. Finds Liaison Officers are generally based within the local museums service and are thus well placed to put dredging companies in touch with institutions that may be able to help them with conservation or placing artefacts.

Issues of ownership and responsibility need to be resolved and clear guidance needs to be produced so that the artefacts may be used effectively rather than allowing them to disintegrate. For example, there is high potential for artefacts to be used as part of local outreach programmes in schools or museums. The public benefits of such programmes should be discussed with the dredging companies and avenues of funding for conservation investigated.

Conclusion

The discoveries reported during 2005-2006 demonstrate a positive response to the Protocol following its publication and indicate a successful launch of the Implementation Service. The value of the discoveries and the contribution being made by the marine aggregates industry is acknowledged by EH and the role of BMAPA in promoting a responsible attitude to the marine historic environment is commended.

Following the publication of the Protocol a number of issues have been raised that need to

be addressed although it is clear that all parties remain committed to the resolution of these issues and to the efficient application of the Protocol.

It is important to continue building upon the successes of the first year, to further expand baseline data for archaeology on the seabed and to deepen our understanding of the marine historic environment. As such, archaeology

professionals and seabed developers will be able to continue to safeguard our heritage and to protect sites for the future.

Through the Protocol, BMAPA has set a precedent for all developers active within the marine environment. It is hoped that similar schemes will be established to incorporate the wide range of industries aiming to minimise their impact upon archaeology.

Appendix
Wharf reports for discoveries 2005-2006



BMAPA/EH

Protocol for Reporting Finds of Archaeological Interest

Hanson_0008_a: Cannonball

This cannonball was found at Hanson's SBV Flushing wharf in September/October 2005 by the Site Champion at this wharf Henk Strijdonk within material dredged from licence area 361 off the coast of Great Yarmouth.

Cannonballs, or round shot, are one of the earliest forms of projectiles fired from cannons. Round shot was made in early times from dressed stone and from iron by the late 15th century until the late 18th century.

Unfortunately this example disintegrated quickly and was disposed of at the wharf in Flushing. Metal artefacts from marine contexts are very unstable once they are removed from the seabed and require professional conservation if they are to survive long term. In the short term the most effective treatment is to keep them submerged in fresh water. No photographs were taken before the artefact was lost.

Finds of cannonballs on the seabed may relate either to the location of a battle (such shot will often exhibit signs of firing or impact damage) or to the location of a shipwreck. The durability of metallic elements compared to wood and other organics means that older shipwrecks, or shipwrecks in high energy environments, are often represented solely by cannon and concreted shot on the seabed. Even reports of individual cannonballs can therefore tell us much about warfare at sea or potentially pinpoint the location of a currently unidentified shipwreck.

Information about this discovery has been forwarded to:

- English Heritage
- BMAPA
- The Crown Estate
- The Receiver of Wreck
- The National Monuments Record
- The Historic Environment Record for Norfolk
- The Local Government Archaeology Officer for Norfolk
- The Finds Liaison Officer (Portable Antiquities Scheme) for Norfolk



Hanson_0008_b: Wooden Sheave

This wooden sheave was found at Hanson's SBV Flushing wharf in October 2005 by the Site Champion at this wharf Henk Strijdonk within material dredged from licence area 361 off the coast of Great Yarmouth.

A 'sheave' is the name given to a wheel or disk with a grooved rim used as a pulley as part of a ship's rigging system. The design of this sheave with a metal coak (strengthening piece) inserted in the centre suggests that it is post 1850s in date.

The sheave is well worn around the outer edge, although the faces are in better condition. This may suggest that the sheave had been in use for some time before being lost on the seabed.

It has not been possible to identify the ship from which this find may have originated although the discovery of further wreck material from the area would greatly enhance the possibility of pinpointing the location of a currently unidentified shipwreck.

Information about this discovery has been forwarded to:

- English Heritage
- BMAPA
- The Crown Estate
- The Receiver of Wreck
- The National Monuments Record
- The Historic Environment Record for Norfolk
- The Local Government Archaeology Officer for Norfolk
- The Finds Liaison Officer (Portable Antiquities Scheme) for Norfolk



BMAPA/EH

Protocol for Reporting Finds of Archaeological Interest



Hanson_0008_c: Whale Bone Fragments

Two pieces of bone found at Hanson's SBV Flushing wharf in October 2005 by the Site Champion at this wharf Henk Strijdonk within material dredged from licence area 361 off the coast of Great Yarmouth.

These two pieces of bone were identified from photographs as cetacean (dolphin, porpoise and whales) in origin by Richard Sabin, Curator of Mammals at the Natural History Museum. The skeletal remains of dolphins and porpoises are more fragile than these fairly robust fragments suggesting that these come from a type of whale.

It has not been possible to identify species or age from the photographs although the eroded surfaces and fossilised appearance suggests that they are prehistoric rather than modern.

The Natural History Museum has been recording cetacean remains since 1913 and all items of whale bone reported through the protocol are being forwarded to the Museum for their records. In this way we can contribute to a national understanding of cetacean occurrences throughout prehistory to the present day.

Information about this discovery has been forwarded to:

- English Heritage
- BMAPA
- The Crown Estate
- The Natural History Museum
- The National Monuments Record
- The Historic Environment Record for Norfolk
- The Local Government Archaeology Officer for Norfolk
- The Finds Liaison Officer (Portable Antiquities Scheme) for Norfolk



BMAPA/EH

Protocol for Reporting Finds of Archaeological Interest



CEMEX_0015_a: Bone Fragment

Piece of bone found on board the CEMEX dredger Sand Heron by Gregorz Przelakowski within material dredged in the NE of licence Area 107 c. 10 miles off the coast of Lincolnshire. The bone was spotted on top of a cargo, prior to discharge, on 15th October 2005.

This small piece of bone is triangular in shape but appears to have been accidentally broken rather than deliberately shaped. The surface is patinated and it has not proved possible to identify the species through visual examination.

Animals were carried on board ships as cargo and as provisions and animal bone from sheep, horses, cattle and pigs, for example, may end up on the seabed as a result of a shipwreck or through simple waste disposal. Animal remains may also end up in marine contexts having been washed from terrestrial deposits by rivers or eroded from cliffs or beaches. Alternatively they may date to a time when the seabed was dry land.

During an ice age more of the world's water is incorporated within ice sheets on land and sea level drops exposing areas of the seabed. When the ice melts at the end of an ice age the water floods back into the seas and oceans and the sea level rises again, inundating wide expanses of dry land.

At the height of the last ice age c. 18,000 years ago the North Sea would have been dry land. Sea level did not reach its current level until c. 5,000 years ago. It is possible, therefore, that this piece of bone may have originated from a prehistoric landscape which now lies submerged on the seabed.

As it is not been possible to identify the species it is difficult to determine how this piece of bone ended up on the seabed. The discovery of further material from this area, however, will aid identification and potentially help us to identify an unknown archaeological site on the seabed.

Information about this discovery has been forwarded to:

- English Heritage
- BMAPA
- The Crown Estate
- The National Monuments Record
- The Historic Environment Record for Lincolnshire
- The Local Government Archaeology Officers for Lincolnshire
- The Finds Liaison Officer (Portable Antiquities Scheme) for Lincolnshire



BMAPA/EH

Protocol for Reporting Finds of Archaeological Interest



CEMEX_0015_b: Possible Structural Elements

Two pieces of iron found on board the CEMEX dredger Sand Heron by Gregorz Przelakowski within material dredged in the NE of licence Area 107 c. 10 miles off the coast of Lincolnshire. The finds were spotted on top of a cargo, prior to discharge, on 15th October 2005.

Of the two pieces of iron reported by CEMEX one appears to be wrought and the other cast.

Wrought iron is commercially pure iron, having a very small carbon content but usually containing some slag. "Wrought" essentially means "worked" and wrought iron is tough and malleable enabling the product to be hammered and welded to make various objects. It has been used for thousands of years and is the 'iron' referred to historically.

Cast iron is a hard and brittle, non malleable iron-carbon alloy. It cannot be worked but is melted and cast in a mould. Cast iron was known in China during prehistoric times and was in general use in Britain in the 16th century. Its earliest uses include cannon and shot although it did not become widely used for structural purposes until the later 18th century.

The wrought iron piece is heavily abraded and it is impossible to determine the purpose that it may have fulfilled. The cast iron piece appears to be broken but the shape indicates that it may have formed part of a ship's knee, a supporting structural element.

It has not been possible to identify a ship from which these finds may have originated although the discovery of further wreck material from the area would greatly enhance the possibility of pinpointing the location of a currently unidentified shipwreck.

Information about this discovery has been forwarded to:

- English Heritage
- BMAPA
- The Crown Estate
- The Receiver of Wreck
- The National Monuments Record
- The Historic Environment Record for Lincolnshire
- The Local Government Archaeology Officers for Lincolnshire
- The Finds Liaison Officer (Portable Antiquities Scheme) for Lincolnshire



BMAPA/EH

Protocol for Reporting Finds of Archaeological Interest



Hanson_0018_a: Ice Age Mammal Remains

These fragments of tooth and bone were found at Hanson's SBV Flushing wharf by the Site Champion at this wharf Henk Strijdonk within material dredged from licence area 361 off the coast of Great Yarmouth, East Anglia.

These fragments are reported as comprising mammoth teeth and bone and a piece of deer bone. The woolly mammoth evolved from earlier mammoth species, adapting to a cooling climate in Northern Europe and North America c. 300,000 years ago. They became extinct at the end of the last ice age c. 10,000 years ago.

The remains of ice age mammals such as deer and woolly mammoth may end up in marine contexts having been washed from terrestrial deposits by rivers or eroded from cliffs or beaches. Alternatively they may date to a time when the seabed was dry land.

During an ice age more of the world's water is incorporated within ice sheets on land and sea level drops exposing areas of the seabed. When the ice melts at the end of an ice age the water floods back into the seas and oceans and the sea level rises again, inundating wide expanses of dry land.

At the height of the last ice age c. 18,000 years ago the North Sea would have been dry land. Sea level did not reach its current level until c. 5,000 years ago. It is possible, therefore, that these fragments of bone may have originated from a prehistoric landscape which now lies submerged on the seabed.

Photographs of the finds were sent to Andy Currant, Curator of Mammals at the Natural History Museum but he was unable to offer any further information from the available photographs. The fragmentary nature of the pieces means that identification of a specific skeletal element is difficult without closer and more detailed analysis. However, the number of bone and teeth fragments suggest that area 361 may have high potential for identifying prehistoric landscapes and may help us to locate sites of enormous archaeological importance.

Information about this discovery has been forwarded to:

- English Heritage
- BMAPA
- The Crown Estate
- The National Monuments Record
- The Historic Environment Record for Norfolk
- The Local Government Archaeology Officer for Norfolk
- The Finds Liaison Officer (Portable Antiquities Scheme) for Norfolk



BMAPA/EH

Protocol for Reporting Finds of Archaeological Interest



Hanson_0019_a: Possible Zeppelin Bomb

This bomb was found on board the Hanson vessel Arco Dijk by the Captain A. R. Greenway within material dredged from licence area 408 c. 70 miles off Spurn Point in the Humber region.

This bomb was originally thought to be a Zeppelin bomb from WWI.

The Zeppelin was a type of airship pioneered by Count Ferdinand von Zeppelin in the early 20th century. The outstanding success of the design saw the term Zeppelin coming into casual use as a term for all airships. During the first world war the German military made extensive use of Zeppelins as bombers and scouts. Of the eighty-eight built during the war over sixty were lost.

The recovery of munitions or structure from a zeppelin would be of high archaeological and historical importance. Unfortunately this example was ultimately shown to be a modern practice bomb.

Information about this discovery has been forwarded to:

- English Heritage
- BMAPA
- The Crown Estate
- The National Monuments Record
- The Historic Environment Record for North Lincolnshire
- The Local Government Archaeology Officers for North Lincolnshire, Kingston Upon Hull and the East Riding
- The Finds Liaison Officer (Portable Antiquities Scheme) for North Lincolnshire



BMAPA/EH

Protocol for Reporting Finds of Archaeological Interest



UMD_0021_a: Mammoth Humerus

Large section of bone found at United Marine Aggregates' wharf at Ridham Dock by the wharf manager Jo O'Brien. The date of dredging and the dredging area are unknown.

This bone was identified from this photograph as a large section of animal humerus by Jessica Grimm (Animal Bone Specialist, Wessex Archaeology). The bone is c.30cm long, much larger than that of a horse, auroch or giant deer and most probably from a mammoth.

The woolly mammoth evolved from earlier mammoth species, adapting to a cooling climate in Northern Europe and North America c. 300,000 years ago. They became extinct at the end of the last ice age c. 10,000 years ago.

The remains of ice age mammals such as the woolly mammoth may end up in marine contexts having been washed from terrestrial deposits by rivers or eroded from cliffs or beaches. Alternatively they may date to a time when the seabed was dry land.

During an ice age more of the world's water is incorporated within ice sheets on land and sea level drops exposing areas of the seabed. When the ice melts at the end of an ice age the water floods back into the seas and oceans and the sea level rises again, inundating wide expanses of dry land.

At the height of the last ice age c. 18,000 years ago the North Sea would have been dry land. Sea level did not reach its current level until c. 5,000 years ago. It is possible, therefore, that this section of bone may have originated from a prehistoric landscape which now lies submerged on the seabed. Unfortunately, as the location of the discovery on the seabed is unknown it is not possible to use this find to identify any such submerged sites.

Information about this discovery has been forwarded to:

- English Heritage
- BMAPA
- The Crown Estate
- The National Monuments Record
- The Sites and Monuments Record for Kent
- The Local Government Archaeology Officer for Kent
- The Finds Liaison Officer (Portable Antiquities Scheme) for Kent



BMAPA/EH

Protocol for Reporting Finds of Archaeological Interest



UMD_0022_a: Metal Objects

A selection of metal objects found at United Marine Aggregates' wharf at Bedhampton Quay in January 2006 by Darren Taylor. The material came from the vessel City of Chichester but specific data on the licence area or load is unknown.

The metal objects include a rowlock, fishing weight and an unidentified, ornamental object.

The object in the bottom left hand corner appears to be a broken rowlock, a holder attached to the gunwale of a boat that holds the oar in place and acts as a fulcrum for rowing. It is not possible to determine the craft from which this artefact originated, or the date of the find. It may have come from a shipwreck although it may simply have been discarded or lost overboard.

The object in the top left hand corner comprises a short section of wood encased in lead and has been identified from this photograph as a lead fishing net weight. It has not proved possible to determine the date of the find through visual examination alone. Lead has been used by humans for at least 7000 years and may therefore may be prehistoric in date.

The final object, in the top right hand corner, appears to be ornamental and has no obvious function.

Unfortunately, as the location of the discovery on the seabed is unknown, it is not possible to use these finds to identify any archaeological sites or areas of potential on the seabed.

Information about this discovery has been forwarded to:

- English Heritage
- BMAPA
- The Crown Estate
- The Receiver of Wreck
- The National Monuments Record
- The Historic Environment Record for Hampshire
- The Local Government Archaeology Officer for Hampshire
- The Finds Liaison Officer (Portable Antiquities Scheme) for Hampshire



UMD_0026_a: Metal Hook

Metal hook discovered within dredged material at United Marine Aggregates' wharf in Erith. The date and location of the discovery is unknown.

This metal hook has been identified from this photograph as a boat hook or grappling iron. It is possible that may also be part of an anchor or fishing equipment. The lack of rust and concretion indicates that the find is modern in date or that the find was buried until very recently.

The appearance suggests that it is made of wrought iron. Wrought iron is commercially pure iron, having a very small carbon content but usually containing some slag. "Wrought" essentially means "worked" and wrought iron is tough and malleable enabling the product to be hammered and welded to make various objects. It has been used for thousands of years and is the 'iron' referred to historically.

Unfortunately, as the location of the discovery on the seabed is unknown, it is not possible to use this find to identify any archaeological sites or areas of potential on the seabed.

Information about this discovery has been forwarded to:

- English Heritage
- BMAPA
- The Crown Estate
- The Receiver of Wreck
- The National Monuments Record



BMAPA/EH

Protocol for Reporting Finds of Archaeological Interest



Hanson_0035_a: Mammoth Tusk

This mammoth tusk fell off the conveyor belt just as it was about to enter the crusher at Purfleet Aggregates in Thurrock, Essex. The tusk was discovered in February 2006 by Mick Hayward within material dredged by the Hanson vessel Arco Humber in licence area 408 c. 50 miles NE of the wash, known as the 'Coal Pit'.

Mammoths are relatively rare fossils in Britain. They occur from the Wolstonian ice age (380,000 to 130,000 years ago) to the end of the Devensian ice age (c. 10,000 years ago) but there are few dated examples.

The tusk from Area 408 is one of the most northerly examples of *Mammuthus primigenius* for which good positional data is available. For this reason, English Heritage's Scientific Dating section submitted samples from the tusk for AMS dating at the Oxford Radiocarbon Accelerator Unit, University of Oxford, and the Centre for Isotope Research at the University of Groningen. Two results have so far been received suggesting a date of 44,250 (+/-600 years) Before Present (BP).

A further sample is being dated for quality-control purposes and the result is expected in early December 2006. However, at present the tusk appears to date to the end of the Middle Palaeolithic (150,000 to 40,000 BP), during the Devensian ice age, before the earliest evidence for Cro-magnon man in what is now Britain and when Neanderthal populations predominated.

Advice on the conservation of the tusk was sought from Andy Currant, Collections Manager in the Palaeontology department of the Natural History Museum. He recommended that as much salt as possible should be washed out of the tusk before drying it slowly and storing it in a humid atmosphere. Drying the tusk too quickly and too completely is likely to result in irreversible distortion.

Wessex Archaeology has been soaking the tusk in clean water to remove the salt since its recovery. Once appropriate storage for the tusk has been agreed with Hanson and English Heritage an attempt will be made to dry out the tusk slowly by covering the tusk in wet sand and leaving it to dry naturally.

This discovery has high potential to contribute to our knowledge of climate and the limits of the ice front during the last ice age and may have significant implications for understanding of the distribution of *Mammuthus primigenius*, a potentially exploitable resource for human populations. Once the final result has been received the archaeological significance of the discovery will be fully assessed and published. However, this result is an important addition to the compendium of Mammoth dates and highlights the value of the Protocol.

Information about this discovery will be forwarded to:

- English Heritage
- BMAPA
- The Crown Estate
- The National Monuments Record
- The local Sites and Monuments Records/Historic Environment Records for Lincolnshire, East Yorkshire and Norfolk;
- The Local Government Archaeology Officer for Lincolnshire, East Yorkshire and Norfolk;
- The Finds Liaison Officer (Portable Antiquities Scheme) for Essex.



BMAPA/EH

Protocol for Reporting Finds of Archaeological Interest

CEMEX_0039_a: Eroding Peat Layer

A collection of wood and other artefacts was reported from the Steenkorrel wharf in Amsterdam in February 2006. The material came from a load dredged by the CEMEX vessel Sand Falcon from licence area 360 off Great Yarmouth.

A collection of dark, decaying waterlogged pieces of wood was reported by CEMEX in May 2006. The proximity of the discovery to the wreck *Cornmead* which sank in 1941 led to the assumption that the wood may be related to the remains of this wreck.

CEMEX kindly made the collection available to Wessex Archaeology for inspection by our finds specialists and it soon became clear that a relationship between the wood and the wreck *Cornmead* was unlikely. The collection was found to contain not only wood but also peat, mineralised bone, antler and a single piece of struck flint.

The wood was analysed by Cathie Chisham, Palaeobotanist at Wessex Archaeology. She identified that the wood is unworked suggesting that it represents the natural environment rather than a structure such as a ship wreck, fish trap or terrestrial structure. The bone was examined by Jessica Grimm, animal bone specialist at Wessex Archaeology. The fragments were heavily mineralised and it was not possible to identify the species although all are of large mammals, probably herbivores. Three fragments of antler were identified as deer. Finally, the struck flint was identified as man made by Matt Leivers, flint specialist at Wessex Archaeology.

The nature of the recovery of the remains means that it is not possible to guarantee that all of the items are contemporary. However, the presence of reworked fragments of peat is certainly suggestive that the material has been eroded out of a peat layer. If we assume that the material is broadly contemporary then a submerged terrestrial land surface, probably of early Mesolithic date (c. 8,500 BC), is the most likely origin of the material.

During the last ice age a greater proportion of the world's water was incorporated in ice sheets and sea level dropped. As a result large expanses of land, now forming the seabed of the North Sea and the English Channel, were available for human habitation. At the end of the ice age sea levels rose as the ice sheets melted and these areas became submerged. Many of these former terrestrial landscapes lie preserved on the seabed.

The study of submerged prehistoric landscapes and associated archaeological deposits is still a young science and discoveries of such land surfaces are incredibly important for our understanding of the nature and distribution of prehistoric settlements. The field promises to provide a different and valuable source of information about prehistoric peoples and has the potential to expand our knowledge of those societies and inform terrestrial archaeology, possibly even to transform the currently prevalent, terrestrial perspective itself.

Information about this discovery will be forwarded to:

- English Heritage
- BMAPA
- The Crown Estate
- The National Monuments Record
- The Historic Environment Record for Norfolk
- The Local Government Archaeology Officer for Norfolk



BMAPA/EH

Protocol for Reporting Finds of Archaeological Interest



UMD_0041_a: Fragment of Bone

This fragment of bone was found on board United Marine Dredging's vessel City of Westminster by Capt Paul Harrington within material dredged from licence area 254 off the coast of Great Yarmouth.

This broken fragment of bone is approximately 10cm long and was identified from the above photograph as a possible deer metatarsus by Jessica Grimm (Animal Bone Specialist, Wessex Archaeology). Without closer examination it is not possible to identify the species.

Large, wild herbivores, such as deer, have long been present in northern Europe and this bone may be prehistoric in date.

During the last ice a greater proportion of the world's water was incorporated in the ice sheets and sea level dropped. As a result large expanses of land, now forming the seabed of the North Sea and the English Channel, were available for population by humans and animals. At the end of the ice age sea levels rose as the ice sheets melted and these areas became submerged. Many of these former terrestrial landscapes lie preserved on the seabed.

It is not currently possible to confirm a date for the bone although the discovery of further material from the same area may support a prehistoric interpretation. As further discoveries are reported and mapped it may be possible to identify meaningful patterns in the distribution of finds that will aid archaeologists in the identification of sites and archaeologically sensitive areas on the seabed. This is of benefit to both the public in general and to the marine aggregate industry in enabling companies and curators to be quickly alerted to the presence of archaeological sites that can be better protected as a result.

Information about this discovery has been forwarded to:

- English Heritage
- BMAPA
- The Crown Estate
- The National Monuments Record
- The Historic Environment Record for Norfolk
- The Local Government Archaeology Officer for Norfolk
- The Finds Liaison Officer (Portable Antiquities Scheme) for Norfolk



BMAPA/EH

Protocol for Reporting Finds of Archaeological Interest



UMD_0042_a: Fragments of Bone

These fragments of bone were found at United Marine Aggregates' wharf at Bedhampton Quay in February 2006 by Darren Taylor. The artefacts were discovered within material dredged by the vessel City of Chichester in licence area 122/3 off the Isle of Wight.

These fragments of bone were identified from the above photograph as the pelvis of a horse and a scapula, rib and long bone from horse, cattle or deer by Jessica Grimm (Animal Bone Specialist, Wessex Archaeology).

Large, wild herbivores, such as deer, horse and cattle have long been present in northern Europe and the bones may be prehistoric in date.

During the last ice a greater proportion of the world's water was incorporated in the ice sheets and sea level dropped. As a result large expanses of land, now forming the seabed of the North Sea and the English Channel, were available for population by humans and animals. At the end of the ice age sea levels rose as the ice sheets melted and these areas became submerged. Many of these former terrestrial landscapes lie preserved on the seabed.

From the beginning of the Neolithic (c. 4,000 BC) human populations in what is now Britain began to domesticate animals such as horse and cattle for agriculture. By this time, however, sea level had risen to roughly what it is today and any bones of this date or later will have been washed offshore from terrestrial deposits, or possibly associated with the cargo or provisions carried on board a shipwreck.

Without closer examination it is not possible to identify the species, nor confirm a date for the bones. However, as further discoveries are reported and mapped it may be possible to identify meaningful patterns in the distribution of finds that will aid archaeologists in the identification of sites and archaeologically sensitive areas on the seabed. This is of benefit to both the public in general and to the marine aggregate industry in enabling companies and curators to be quickly alerted to the presence of archaeological sites that can be better protected as a result.

Information about this discovery has been forwarded to:

- English Heritage
- BMAPA
- The Crown Estate
- The National Monuments Record
- The Sites and Monuments Record for the Isle of Wight
- The Local Government Archaeology Officer for the Isle of Wight
- The Finds Liaison Officer (Portable Antiquities Scheme) for Hampshire



BMAPA/EH

Protocol for Reporting Finds of Archaeological Interest



UMD_0043_a: Fragment of Tooth

This fragment of tooth was found at United Marine Aggregates' wharf at Bedhampton Quay in May 2006 by Darren Taylor. The fragment was discovered within material dredged by the vessel City of Chichester in licence area 127 off the Isle of Wight.

This fragment of tooth is approximately 12.5cm long and was identified from the above photograph as part of a woolly mammoth tooth (*Mammuthus primigenius*) by Jessica Grimm (Animal Bone Specialist, Wessex Archaeology).

Mammoths are relatively rare fossils in Britain. They occur from the Wolstonian ice age (380,000 to 130,000 years ago) to the end of the Devensian ice age (c. 10,000 years ago) but there are few dated examples. It is not currently possible to confirm a date for the tooth.

This discovery has been added to the currently available baseline data for the marine historic environment in the South Coast region. As further discoveries are reported and mapped it may be possible to identify meaningful patterns in the distribution of finds that will aid archaeologists in the identification of sites and archaeologically sensitive areas on the seabed. This is of benefit to both the public in general and to the marine aggregate industry in enabling companies and curators to be quickly alerted to the presence of archaeological sites that can be better protected as a result.

Information about this discovery has been forwarded to:

- English Heritage
- BMAPA
- The Crown Estate
- The National Monuments Record
- The Sites and Monuments Record for the Isle of Wight
- The Local Government Archaeology Officer for the Isle of Wight
- The Finds Liaison Officer (Portable Antiquities Scheme) for Hampshire



BMAPA/EH

Protocol for Reporting Finds of Archaeological Interest



UMD_0044_a: Fragments of Bone

These fragments of bone were found at United Marine Aggregates' wharf at Bedhampton Quay in May 2006 by Gary Cooper. The artefacts were discovered within material dredged by the vessel City of Chichester in licence area 122/3 off the Isle of Wight.

These fragments of bone were identified from the above photograph as a pelvis and long bone from horse, cattle or deer by Jessica Grimm (Animal Bone Specialist, Wessex Archaeology).

Large, wild herbivores, such as deer, horse and cattle have long been present in northern Europe and the bones may be prehistoric in date.

During the last ice a greater proportion of the world's water was incorporated in the ice sheets and sea level dropped. As a result large expanses of land, now forming the seabed of the North Sea and the English Channel, were available for population by humans and animals. At the end of the ice age sea levels rose as the ice sheets melted and these areas became submerged. Many of these former terrestrial landscapes lie preserved on the seabed.

From the beginning of the Neolithic (c. 4,000 BC) human populations in what is now Britain began to domesticate animals such as horse and cattle for agriculture. By this time, however, sea level had risen to roughly what it is today and any bones of this date or later will have been washed offshore from terrestrial deposits, or possibly associated with the cargo or provisions carried on board a shipwreck.

Without closer examination it is not possible to identify the species, nor confirm a date for the bones. However, as further discoveries are reported and mapped it may be possible to identify meaningful patterns in the distribution of finds that will aid archaeologists in the identification of sites and archaeologically sensitive areas on the seabed. This is of benefit to both the public in general and to the marine aggregate industry in enabling companies and curators to be quickly alerted to the presence of archaeological sites that can be better protected as a result.

Information about this discovery has been forwarded to:

- English Heritage
- BMAPA
- The Crown Estate
- The National Monuments Record
- The Sites and Monuments Record for the Isle of Wight
- The Local Government Archaeology Officer for the Isle of Wight
- The Finds Liaison Officer (Portable Antiquities Scheme) for Hampshire



BMAPA/EH

Protocol for Reporting Finds of Archaeological Interest



UMD_0045_a: Mammoth Tooth

This fragment of tooth was found at United Marine Aggregates' wharf in Erith in April 2006 by Rick Bodle. The tooth was discovered within material dredged by the vessel City of Westminster in licence area 254 off Great Yarmouth.

This fragment of tooth is approximately 30cm long and was identified from the above photograph as a mammoth tooth by Jessica Grimm (Animal Bone Specialist, Wessex Archaeology). Andy Currant (Collections Manager in the Palaeontology department of the Natural History Museum) suggested that the photograph shows half of a very fine third upper molar of a woolly mammoth (*Mammuthus primigenius*).

Mammoths are relatively rare fossils in Britain. They occur from the Wolstonian ice age (380,000 to 130,000 years ago) to the end of the Devensian ice age (c. 10,000 years ago) but there are few dated examples. It is not currently possible to confirm a date for the tooth.

This discovery has been added to the currently available baseline data for the marine historic environment in the East Coast region. As further discoveries are reported and mapped it may be possible to identify meaningful patterns in the distribution of finds that will aid archaeologists in the identification of sites and archaeologically sensitive areas on the seabed. This is of benefit to both the public in general and to the marine aggregate industry in enabling companies and curators to be quickly alerted to the presence of archaeological sites that can be better protected as a result.

Information about this discovery has been forwarded to:

- English Heritage
- BMAPA
- The Crown Estate
- The National Monuments Record
- The Historic Environment Record for Norfolk
- The Local Government Archaeology Officer for Norfolk
- The Finds Liaison Officer (Portable Antiquities Scheme) for London



BMAPA/EH

Protocol for Reporting Finds of Archaeological Interest



UMD_0059: Aircraft Remains

These fragments were found at United Marine Aggregates' wharf at Ridham Dock in July 2006 by Tony Miller and Gary Phillips. The fragments were discovered within material dredged by the vessel City of London in licence area 254 off Great Yarmouth.

These fragments of aluminium most likely represent parts of a crashed aircraft. Photographs of the remains were sent to Andy Simpson at the RAF museum but, without any serial numbers or identifiable features, it has not proved possible to identify the type of aircraft they represent. He did indicate, however, that traces of black paint, apparent in the photograph on the right, indicate that this was a plane which predominantly operated at night. Both British and German aircraft operating at night during WW2 had black undersides and partially or totally black fuselage sides at varying periods of the war.

Crashed aircraft are important to archaeologists because in many cases they offer a unique form of evidence for the historic development of flight. If surviving examples of a particular type of craft do exist they are often only the later models of a particular type or they have been heavily refurbished. Moreover, all crashed military aircraft are protected by law under the Protection of Military Remains Act 1986. The discovery of aircraft remains is thus incredibly important, particularly as aircraft crash sites may contain human remains.

This discovery appears to comprise isolated remains rather than representing a coherent crash site. No obstructions were identified on the seabed and there are no reports of significant aircraft structure caught in the vessel draghead. For this reason the remains are not considered to be contentious, although the discovery of further remains from the same area should be reported immediately.

Information about this discovery has been forwarded to:

- English Heritage and BMAPA
- The Crown Estate
- The Receiver of Wreck
- The MOD
- The National Monuments Record
- The Historic Environment Record for Norfolk
- The Local Government Archaeology Officer for Norfolk
- The Finds Liaison Officer (Portable Antiquities Scheme) for Kent



BMAPA/EH

Protocol for Reporting Finds of Archaeological Interest



UMD_0061: Aircraft Remains

These fragments of aircraft were found at United Marine Aggregates' Greenwich wharf in July 2006 by Paul Tallents. The fragments were discovered within material dredged by the vessel City of London in licence area 430 off Southwold.

Photographs of these parts were sent to Andy Simpson at the RAF museum but, despite the presence of a part number and a BOSHH symbol, it has not proved possible to identify the type of aircraft they represent. He suggested that the gear and cog wheels are most likely engine related, possibly propeller reduction, pitch control gear or engine supercharger, but it is not possible to offer any further interpretation.

Crashed aircraft are important to archaeologists because in many cases they offer a unique form of evidence for the historic development of flight. If surviving examples of a particular type of craft do exist they are often only the later models of a particular type or they have been heavily refurbished. Moreover, all crashed military aircraft are protected by law under the Protection of Military Remains Act 1986. The discovery of aircraft remains is thus incredibly important, particularly as aircraft crash sites may contain human remains.

Although this discovery was found in a similar area to further plane parts (UMD_0062_a) this report appears to comprise isolated remains rather than representing a coherent crash site. No obstructions were identified on the seabed and there are no reports of significant aircraft structure caught in the vessel draghead. For this reason the remains are not considered to be contentious, although the discovery of further remains from the same area should be reported immediately.

Information about this discovery has been forwarded to:

- English Heritage
- BMAPA
- The Crown Estate
- The Receiver of Wreck
- The MOD
- The National Monuments Record
- The Historic Environment Record for Suffolk
- The Local Government Archaeology Officer for Suffolk
- The Finds Liaison Officer (Portable Antiquities Scheme) for London



BMAPA/EH

Protocol for Reporting Finds of Archaeological Interest



UMD_0062: Rudder Pedal and Lamp

These artefacts were found at United Marine Aggregates' Greenwich wharf in June 2006 by Paul Tallents within material dredged by the vessel City of London in licence area 430 off Southwold.



The pedal pictured above is engraved with the logo for the North American Aviation Company, an aircraft manufacturer focusing on the construction of small single-engined planes in the 1930s and which built more military aircraft between 1935 and 1967 than any other manufacturer in U.S. history. The presence of this logo suggests that the pedal comes from either the P-51 Mustang fighter or the B-25 Mitchell bomber, both manufactured for the U.S. air force by North American Aviation and used widely in Europe during the Second World War.

Photographs of the two parts were sent to Andy Simpson at the RAF museum. The museum has surviving examples of both the P-51 and the B-25 and an aircraft technician at the museum was able to examine both planes to find matches for the parts. The pedal in the picture matched the rudder pedal on both planes! Unfortunately, a serial number identified on the lamp was no more helpful in identifying the plane. In fact, a match for the lamp could not be found on either aircraft. It is possible that the lamp may be unrelated or that it was an addition to the crashed aircraft in question and not standard equipment.

Crashed aircraft are important to archaeologists because in many cases they offer a unique form of evidence for the historic development of flight. If surviving examples of a particular type of craft do exist they are often only the later models of a particular type or they have been heavily refurbished. Moreover, all crashed military aircraft are protected by law under the Protection of Military Remains Act 1986. The discovery of aircraft remains is thus incredibly important, particularly as aircraft crash sites may contain human remains.

Although this discovery was found in a similar area to further plane parts (UMD_0061_a) this report appears to comprise isolated remains rather than representing a coherent crash site. No obstructions were identified on the seabed and there are no reports of significant aircraft structure caught in the vessel draghead. For this reason the remains are not considered to be contentious, although the discovery of further remains from the same area should be reported immediately.

Information about this discovery has been forwarded to:

- English Heritage and BMAPA
- The Crown Estate
- The Receiver of Wreck
- The MOD
- The National Monuments Record and the Historic Environment Record for Suffolk
- The Local Government Archaeology Officer for Suffolk
- The Finds Liaison Officer (Portable Antiquities Scheme) for London



BMAPA/EH

Protocol for Reporting Finds of Archaeological Interest



CEMEX_0064_a: Cannon ball

This cannon ball was found at CEMEX's Crown Wharf by Dave Davies. It was found in material dredged on 29th July 2006 from licence area 137 off the southwest coast of the Isle of Wight.

Cannon balls, or round shot, are one of the earliest forms of projectiles fired from cannons. Round shot was made in early times from dressed stone and from iron by the late 15th century until the late 18th century.

Finds of cannon balls on the seabed may relate either to the location of a battle (such shot will often exhibit signs of firing or impact damage) or to the location of a shipwreck. The durability of metallic elements compared to wood and other organics means that older shipwrecks, or shipwrecks in high energy environments, are often represented solely by cannon and concreted shot on the seabed. Even reports of individual cannonballs can therefore tell us much about warfare at sea or potentially pinpoint the location of a currently unidentified shipwreck.

Metal artefacts from marine contexts are very unstable once they are removed from the seabed and require professional conservation if they are to survive long term. In the short term the most effective treatment is to keep them submerged in fresh water.

Information about this discovery has been forwarded to:

- English Heritage
- BMAPA
- The Crown Estate
- The Receiver of Wreck
- The National Monuments Record
- The Historic Environment Record for the Isle of Wight
- The Local Government Archaeology Officer for the Isle of Wight
- The Finds Liaison Officer (Portable Antiquities Scheme) for Hampshire



BMAPA/EH

Protocol for Reporting Finds of Archaeological Interest



UMD_0065_a: 2 Stone Fishing Net Weights

These weights were found at United Marine Aggregates' Ridham Dock by Louis Smith in dredged material received from the vessel Arco Beck. The material had been dredged on 19th August 2006 from licence area 296 off the Norfolk coast.

These weights have been fashioned from stone, probably flint, and are of unknown date. They would probably have been used as weights for a fishing net, line or lobster pot. Both items contain a roughly circular hole through which they would have been attached to the fishing gear.

Finding fishing weights is interesting from an archaeological point of view because the location of such a find can tell us about where people were fishing. They also give us information on the diet of the people who lived near here. Fishing is known to have occurred around Britain since early prehistoric times. Some of the earliest discoveries of artefacts have been made by English Heritage of fish traps on the Isle of Wight coast. Fishing weights may have been used in an inshore environment or have been used further out at sea on fishing gear deployed from vessels.

Although the weights have clearly been worked by human agency there is no way of gauging their age, as such items were used from the prehistoric to the post-medieval periods.

Information about this discovery has been forwarded to:

- English Heritage
- BMAPA
- The Crown Estate
- The Receiver of Wreck
- The National Monuments Record
- The Historic Environment Record for Norfolk
- The Local Government Archaeology Officer for Norfolk
- The Finds Liaison Officer (Portable Antiquities Scheme) for Kent



British Marine Aggregate Producers Association
 Gillingham House, 38-44 Gillingham Street
 London SW1V 1HU
 Tel: 0207 963 8000 Fax: 0207 963 8001
 bmapa@qpa.org www.bmapa.org

BMAPA is one of the constituent bodies of the Quarry Products Association, the trade association for the aggregates, asphalt and ready-mixed concrete industries.



ENGLISH HERITAGE

1 Waterhouse Square,
 138-142 Holborn,
 London EC1N 2STT
 Tel 020 7973 3002 Fax 020 7973 3001
 customers@english-heritage.org.uk
 www.english-heritage.org.uk



Wessex Archaeology

Head Office
 Portway House, Old Sarum Park
 Salisbury, Wiltshire SP4 6EB
 Tel 01722 326867 Fax 01722 337562
 info@wessexarch.co.uk
 www.wessexarch.co.uk