

Excavation of a Thirteenth-Century Wooden Building at Weoley Castle, Birmingham, 1960-61

AN INTERIM REPORT

By ADRIAN OSWALD

Keeper of the Department of Archaeology, City of Birmingham Museum

WEOLEY castle (O.S. 1 in. Sheet 131.024828), which lies within the city boundary of Birmingham (FIG. 39), is a fortified manor house whose licence to crenellate goes back to 1264 (Patent Rolls Oxon., 16 October) when Roger de Somery I was granted permission to 'enclose with a ditch and a wall of stone and lime, fortify and crenellate the dwelling house of his Manor of Weoley'. The work took place between this year and 1280, when Roger's grandson was born in the castle. This work is represented by the present walls and the buildings of stone inside them. The walls enclose an area of about an acre and a half surrounded by a very wide moat originally about 8 ft. deep. As might be expected under the terms of the licence, this was not the first building on the site. Excavations which have taken place since 1955 have indicated that at depths of 4 ft. to 6 ft. earlier structures are to be found.¹

In 1960 a determined effort was made to find these levels with the help of labour provided by H.M. Prison at Winson Green. Work continued in 1960 and 1961 for a period of roughly two months each year. A considerable stone building in the NE. part of the castle was discovered (FIG. 40). This structure, made of reused stone, suffered two destructions. It was probably an end hall and was built inside a bank and ditch enclosing a slightly smaller area than the present one. The bank of this defensive structure had post-holes which were dug before the building, for the outside levels of this stone building overlay the clay of the bank. This stone structure came to an end by fire sometime subsequent to 1248. This date rests on a halfpenny of Henry III, in excellent condition, of a type introduced in 1248 (see p. 132). A final date of, perhaps, 1260 might not seem unreasonable for the conclusion of this structure.²

South-west from this building a long trench revealed an immensely interesting wooden structure (FIGS. 40-41) at a depth of 4 ft. to 8 ft. below the present surface. As the site was waterlogged, the actual wood timbers were preserved in many

¹ Excavations by P. B. Chatwin and the late G. M. Bark in 1930-40 recovered the plans of the chapel, guest-house, great hall, kitchen and some chambers of the fourteenth and fifteenth centuries. The work was not published and the notes were almost all destroyed by fire subsequently.

² For details of this building and of the subsequent evolution of the castle see the interim report in *Trans. Birm. Archaeol. Soc.*, LXXVIII (1962), 61 ff.

places to a height of 3 ft. above their original floor-level. The wet summer of 1960 prevented more than the W. end of this building being explored and the excavation in 1961 was solely devoted to recovering as much of its plan and of its history as possible.

The reason why these early buildings lay so deep is that the construction of the present wide moat displaced a large quantity of earth, which was dumped

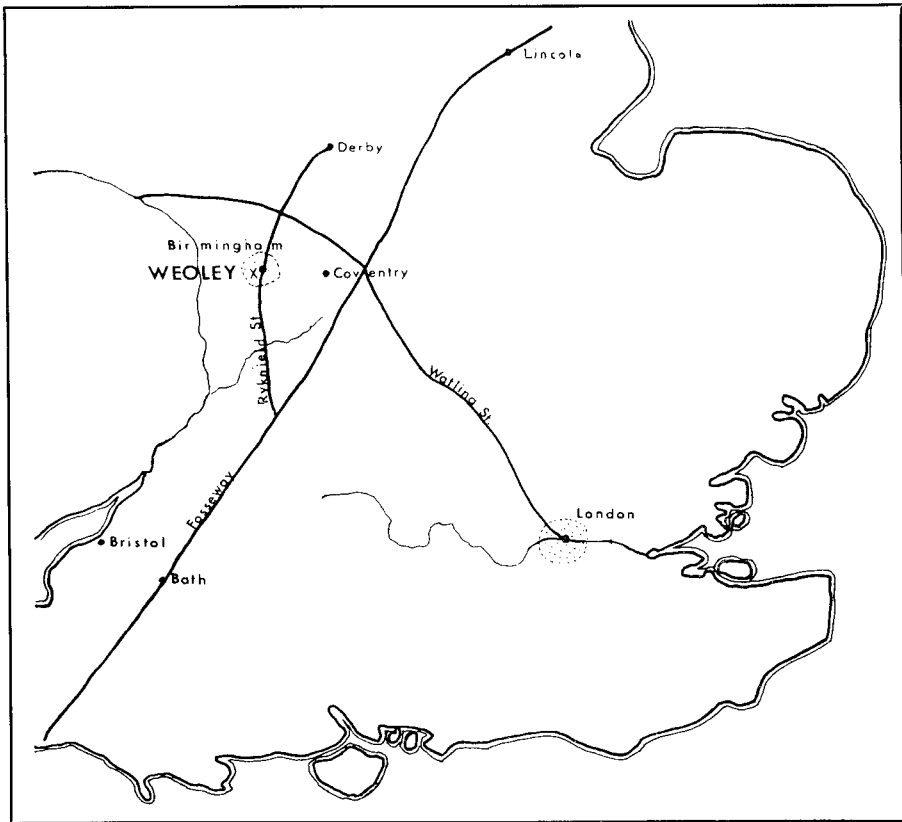
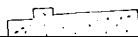

FIG. 39
MAP SHOWING POSITION OF WEOLEY CASTLE, BIRMINGHAM

over the earlier buildings on the site, covering them to a depth of about 4 feet. This dump, in the area of the wooden building, consisted mainly of clay and red sand, which had the effect of excluding all air from the wooden structure and helped to preserve it under the extremely wet conditions of that corner of the castle. These wet conditions seem to have been caused by the accumulation of water behind the earlier bank forming boggy deposits over the whole of the southern half of the castle.

While excavating, it was decided to spare, if possible, the fine restored

moat



Rights have not yet been
granted to use this im-
age in electronic media.
Please refer to printed
article.

FIG. 40

WEOLEY CASTLE, BIRMINGHAM

Position of stone hall (sb) and wooden kitchen (wb) with connecting passage. An earlier wooden structure is shown between the two (p. 122)

Copyright Birmingham City Museum

fifteenth-century hearth of the later kitchen, which extended over a fair proportion of the middle of the building and which is an attraction for visitors. Many later walls were also left, particularly on the south and east where it was clear rotting would prevent any increase in knowledge of building details. The actual digging proceeded under scaffolding and reinforced plastic sheeting. By these methods, despite the wet site, the walls of the excavation stood up to all the assaults of the weather.

An attempted reconstruction of the site *c.* 1260 is shown on FIG. 40 *bis*.

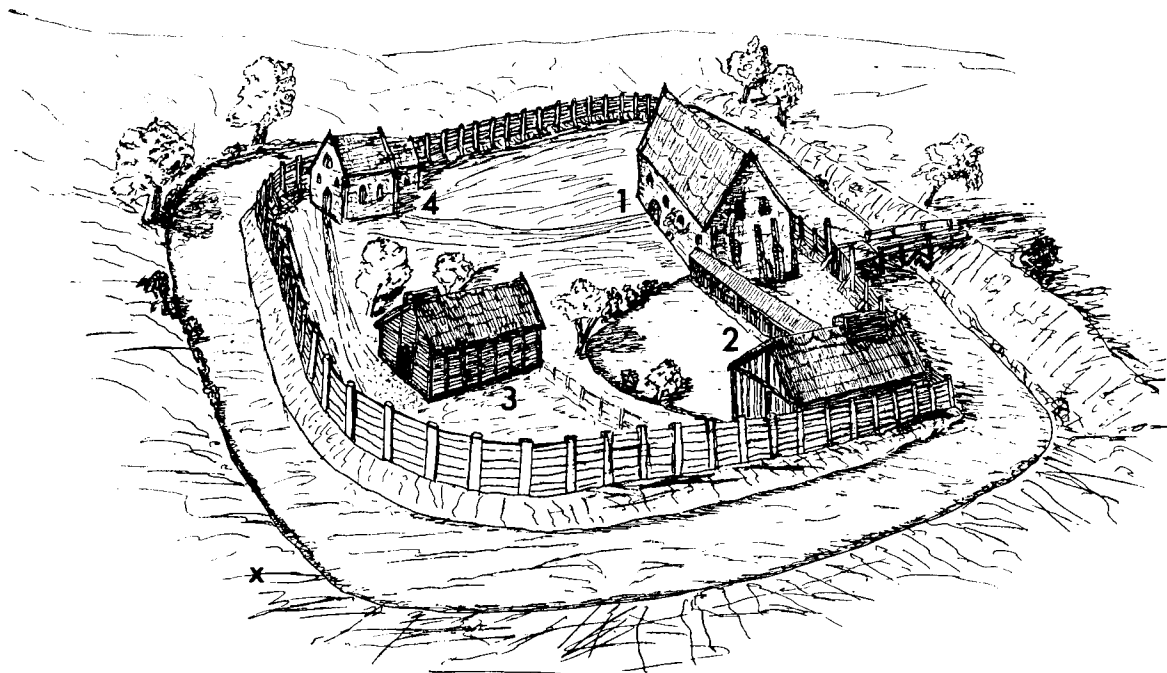

FIG. 40 *bis*

WEOLEY CASTLE, BIRMINGHAM

Possible reconstruction *c.* 1260, looking north

1. Stone building. 2. Wooden building with corridor. 3. Wooden building discovered in 1962. 4. Possible site of chapel indicated by decorative stonework

Copyright Birmingham City Museum

THE WOODEN BUILDING (PL. XII, A, B; FIGS. 41, 42*a, b*, 43, 44)

The building measured 41 ft. 3 in. by 22 ft. 6 in. It was constructed in oak and at the four corners were large upright posts. Only one of these at the NW. corner remained in being, but the slot of the NE. post was observed. Wooden sill beams linked these corner-posts. The wood had rotted on the S. and E. sides, where the beams had been cut into the bank and were not waterlogged. Practically the whole of the N. side and half the W. one was preserved. On the north, between the corner-posts, were three intermediate uprights. Two of these flanked the doorway and that on the east in the centre of the building was particularly

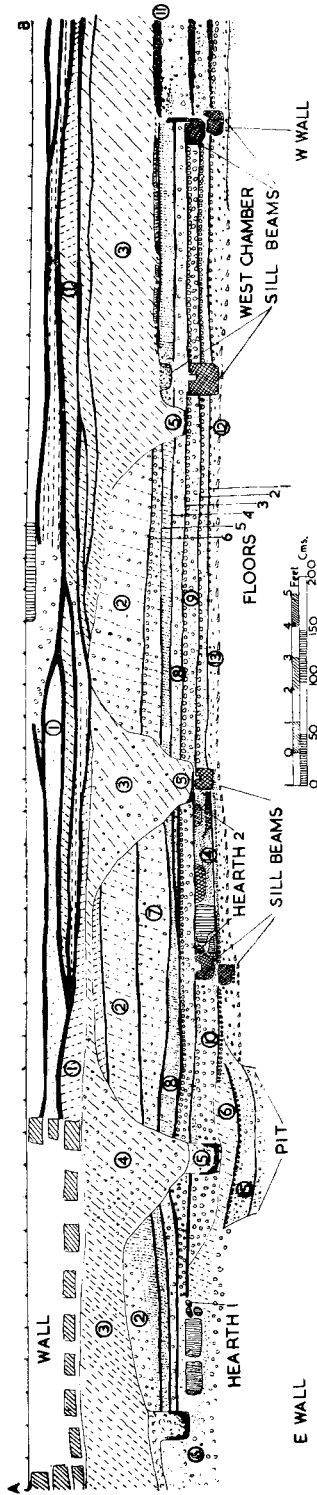

FIG. 42a

WEOLEY CASTLE, BIRMINGHAM

SECTION A-B ACROSS WOODEN BUILDING FROM E. TO W. (pp. 116 ff.)

1. Charcoal layers between pink and grey sandstone; probably rakings from kitchen hearth.
2. Yellow clay and gravel from moat of c. 1270.
3. Red sand from moat of c. 1270.
4. Red sand and gravel from moat of c. 1270.
5. Robbed post-holes of building-periods III-VI.
6. Yellow clay and gravel of early bank.
7. Yellow clay and gravel.
8. Grey and yellow sand of floors 4 and 5.
9. Cobbles of floor 3.
10. Cobbles of floor 2.
11. Black marsh deposits outside building.
12. Sandstone chippings.
13. Brown clay with cut wood.
14. Grey clay of drain (?).
15. Grey yellow silt of pit.

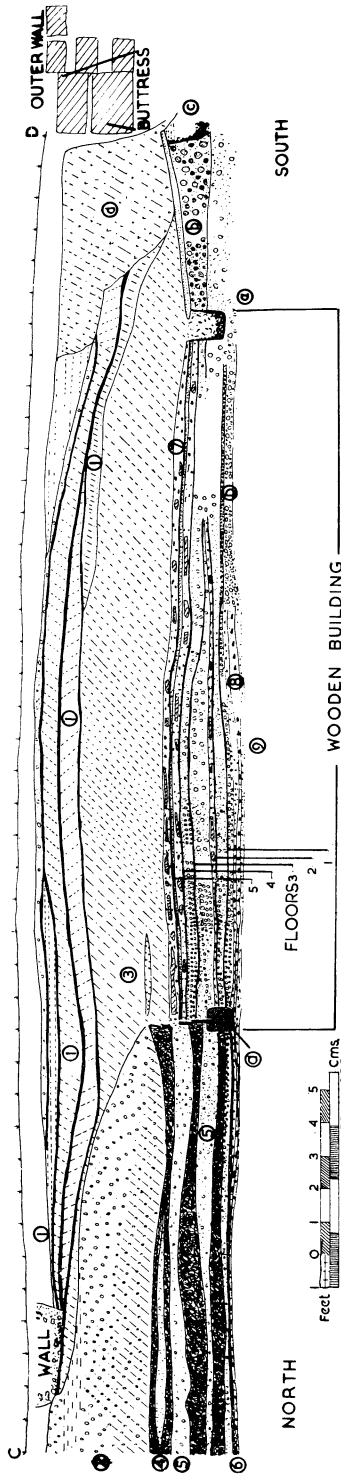

FIG. 42b

WEOLEY CASTLE, BIRMINGHAM

SECTION C-D ACROSS WOODEN BUILDING FROM N. TO S. (pp. 116 ff.)

d. Cut for wall buttress. c. Post-hole of early bank. b. Gravel of early bank. a. Slot for S. wall of building and sill beam of N. wall.

1. Charcoal layers between pink and grey sandstone; probably rakings from kitchen hearth.
2. Yellow clay and gravel from moat of c. 1270.
3. Red sand and gravel from moat of c. 1270.
4. Black marsh deposits outside building.
5. Grey silty clay and cobbles.
6. Brown clay with cut wood.
7. Quantities of timber in the black deposit.
8. Sandstone chippings.
9. Red clay with decomposed twigs.

massive, measuring 18 in. by 6 in. It had been used in a previous building, having grooves cut in it and a hole bored through. Like all these uprights it was flat-bottomed, resting on stones. Its depth below floor 1 was 3 ft. compared with 2 ft. 6 in. for the corner-posts and less for the others. All were dug into large holes, refilled with clean clay. No posts were observed on the W. side. Between these uprights were placed sill beams varying in width between 12 in. and 8 in. and in depth between 10 in. and 6 in. and butting on to the posts. These sill beams carried in their centres vertical posts mortised into them at intervals varying from 4 ft. to 3 ft.; they were also grooved longitudinally to carry the weather-boarding. The vertical uprights were grooved on their sides and into these grooves were slid planks of horizontal weather-boarding, varying in width from 6 in. to 10 in. and in thickness from 1 in. to $\frac{1}{4}$ in., with the thicker planks at the base. This horizontal weather-boarding was certainly used on the N. side and also on the W. side of the building and in the internal partitions. The method of fixing it in the grooves could not be ascertained; neither nails nor pegs were used and perhaps wedges were involved. Rotting prevented any observations on the S. side (PL. XVI, A).

The vertical weather-boarding of period III (p. 117; PL. XVII, A, B) was irregular in width and varied in thickness from 1 in. to $\frac{1}{2}$ in. Boards were pegged either horizontally to the rebate of the sill beam or, as in most cases, diagonally to the base of the beam. They did not appear to be tongued or grooved. The thicker planks overlapped the thinner but the alternation was not consistent. Two mortises on the sill beam for vertical posts may or may not be part of the structure, for the beam may have been reused. The same applies to the northern sill beam (FIG. 44). There was a radical difference in the grooving of these sill beams. For horizontal weather-boarding the grooving was more or less in the centre of the beam. For vertical weather-boarding the outside edge was rebated so that the planks overlapped on to the beam (FIG. 44).

The interior door between the W. chamber and the rest of the house was harr-hung, pivoted at base and top throughout the whole of its life, and it was renewed four, or possibly five, times. Renewal on two occasions was by the insertion of a fresh block of wood at the base as the level was raised. The main door on the north, if one existed, was not pivoted but was swung on some form of hinge (PLS. XIII, B, XIV, A).

Roofing was probably thatch; indeed what appeared to be reeds, perhaps from reed thatch, were found on floor 4. Possibly the heavy concentration of round and apparently burnt twigs 1 in. or so in diameter on floor 1 on the S. side of the W. chamber represents the wattles laid across the roof-timbers before thatching. Some slight clue to the angle of the roof lies perhaps in a plank (PL. XVIII, B) which must have formed the top vertical plank of the end gable. The angles here are 38° , but the cutting is rough and the roof may well have been steeper, as it would need to be for thatch. Heavy timbers found on the top floor-level in the chamber suggested the remains of a very rough truss.

In all it may be said that the building as a whole was rough and its frequent repair showed that it lacked strength. The floor-levels throughout the whole of the building's existence were of gravel.

STRUCTURAL PERIODS

Period I (FIGS. 41, 43, 45)

From the first there was an entrance on the N. side, an entrance which was to persist with certain alterations throughout the life of the building, and from this entrance an apparent path, later a causeway, ran to the SE. corner of the stone hall. In this first stage of construction there was a room at the W. end, the hole for the harr-hung door remaining in the sill beam, which in its turn was fixed to the ground with a long peg (PL. XIII, B). East of this there was another room, or even small hall, on the E. side of which there was a large hearth cut off from the N. wall by a sill beam again carrying horizontal weather-boarding.

The hearth was built of two layers of large sandstone blocks. The interior surface was set with clay, sandstone and cobbles, in the centre of which, much smaller, lay the fire area. It is possible, in this early stage, that this hearth lay outside the building (PL. XVII, C). The very large hole for a small vertical post at the junction of the sill beam proceeding N. from the hearth implies that the building ended at this point, although this could not be confirmed with certainty by excavation.

Period II (FIGS. 41, 43, 45)

The chamber on the W. was narrowed and had its entrance on the N. The large room was cut into by an interior partition, again with grooves for horizontal weather-boarding. The sill beam between the hearth and the N. wall was renewed (FIG. 42, a). The existence of floor 2 (FIG. 42, a), N. of the hearth and E. of this sill, proved that the whole length of the building was in use at this period. There was added to the hearth on the W. an extension of sandstone set in clay, bordered on the N. with what appeared to be a charred beam, and possibly a drain running out of the NE. corner. This extension had some trace of burning on its surface in the centre. It may have been a working area designed more to carry wet slops, and perhaps even a washing-up area (PL. XII, B).

Period III (FIGS. 41, 43, 45)

In the next stage the sill beam at the W. end had rotted and was replaced by another to which was affixed vertical weather-boarding, some of the footings of which were in position (PL. XVII, A, B). The entrance was narrowed. Two beams with a hard cobbled floor in between remained in place (PL. XVI, B). If weather-boarding was used here it was vertical weather-boarding, to judge by the grooves cut in the beams on the external edges. There were, in fact, traces of such boarding on the surface of the causeway. At the doorway one of the door-supports on the W. was renewed. A very curious feature, just to the NE. of this door, was an apparent drain consisting of a large piece of reused oak 2 in. thick, oblong in form, semi-circular in section, with a hole in the middle of it. It had been slid under the weather-boarding of the wall so that it projected inside the building slightly and was cut into one of the main upright supports of the door. It may have served as a pissoir (PL. XIV, B). As before the large hearth continued in use in this period, though reduced in area. The inner door to the chamber was renewed.

An apparent major change in design probably occurred in this period; it

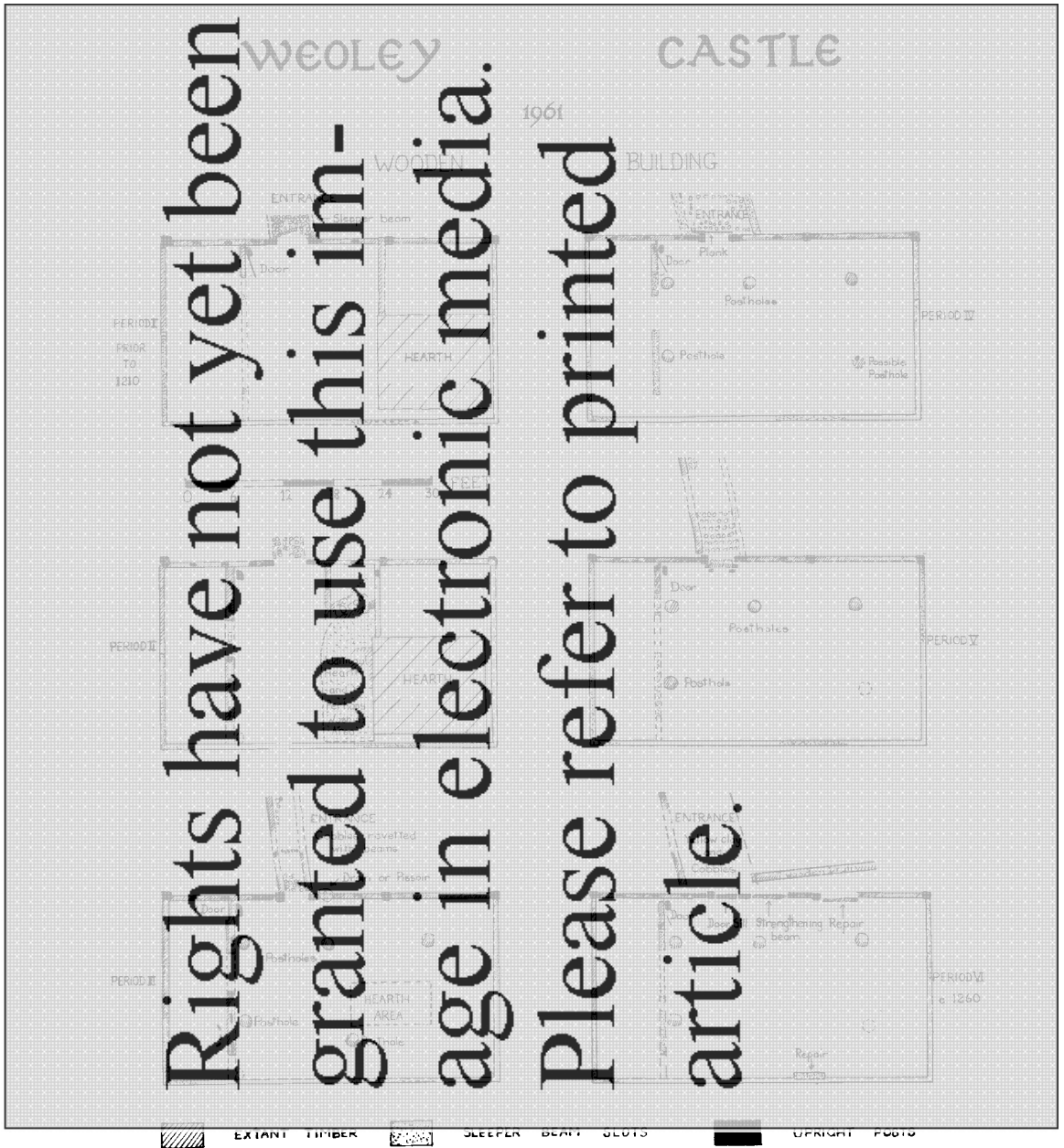

FIG. 43
 WEOLEY CASTLE, BIRMINGHAM
 Development of wooden building (pp. 112 ff.)

Copyright Birmingham City Museum

certainly existed in the later periods. With the exception of the chamber at the W. end, the interior partitions were swept away and the whole of the E. end was converted into an aisled hall with the roof carried on three uprights forming two bays. The post-holes of the uprights on the N. were clearly seen (FIG. 42, *a*, 5) and there was one on the S. also by the W. inner partition. A minor one out of line on the S. may belong also. Its position may be due to the continuance of the hearth (PL. XIII, A).

Period IV (FIGS. 41, 43, 45)

The floor-level was renewed. The big hearth went out of use and presumably was replaced by a smaller one, which, if it exists, must lie under the fifteenth-century hearth. The entrance was widened and was divided from the house by a vertical plank placed across the doorposts (PL. XVI, B). The inner door to the chamber, still harr-hung, was renewed again.

Period V (FIGS. 41, 43, 45)

The major change in this period was a reconstruction of the entrance (PLS. XIV, A, XV, B) with a massive threshold beam notched into the uprights and held in position with two vertical planks. The causeway was slightly widened. The inner door of the chamber received a wooden washer with a piece of leather in the hole to enable the door to swing.

Period VI (FIGS. 41, 43, 45)

The level now appears to have been made up another foot. The entrance was again widened and raised (PL. XV, A) and a curious feature was put down on the NE.—perhaps a long, oak-boarded drain. There was a renewal of the rotted timber walls, particularly on the NE. and the SE. In the final stages the initial dump from the moat, consisting of red sand, brown clay and gravel, was placed over the eastern portion of the building excluding the W. chamber. This was allowed to consolidate (there was in places a vegetation deposit on the surface), then the large upright posts were removed and finally the W. chamber, perhaps used as a contractor's hut till then, was sealed with pure red sand (FIGS. 42, *a*, *b*, 3).

PURPOSE OF THE BUILDING (FIG. 40)

It is suggested that this structure was a kitchen for the stone building. The use of a covered corridor implies that it was desirable to keep the elements at bay for people crossing from one building to another—very necessary if food had to be carried.³

The enormous hearth could only have been used for cooking on a large scale and its enlargement in period II implies even bigger cooking operations. A big hearth also existed in the fifteenth century to the W. of this (p. 112, FIG. 41) but the alteration of the building after period II may imply a change in purpose. Unless there was an earlier hearth under the fifteenth-century one, the building certainly was no longer used as a kitchen.

³ Such corridors and covered alleys are frequently referred to in the Liberate Rolls (M. E. Wood, '13th-century domestic architecture,' *Archaeol. J.*, cv (1958), suppl. p. 115). At Prestbury moat, Gloucestershire, Helen O'Neil found such a pentice leading from the kitchen to the hall door (*Trans. Bristol and Gloucesters. Archaeol. Soc.*, LXXV (1956), 5ff.). See also T. Borenius & J. Charlton, 'Clarendon palace,' *Antiq. J.*, XVI (1936), 72.

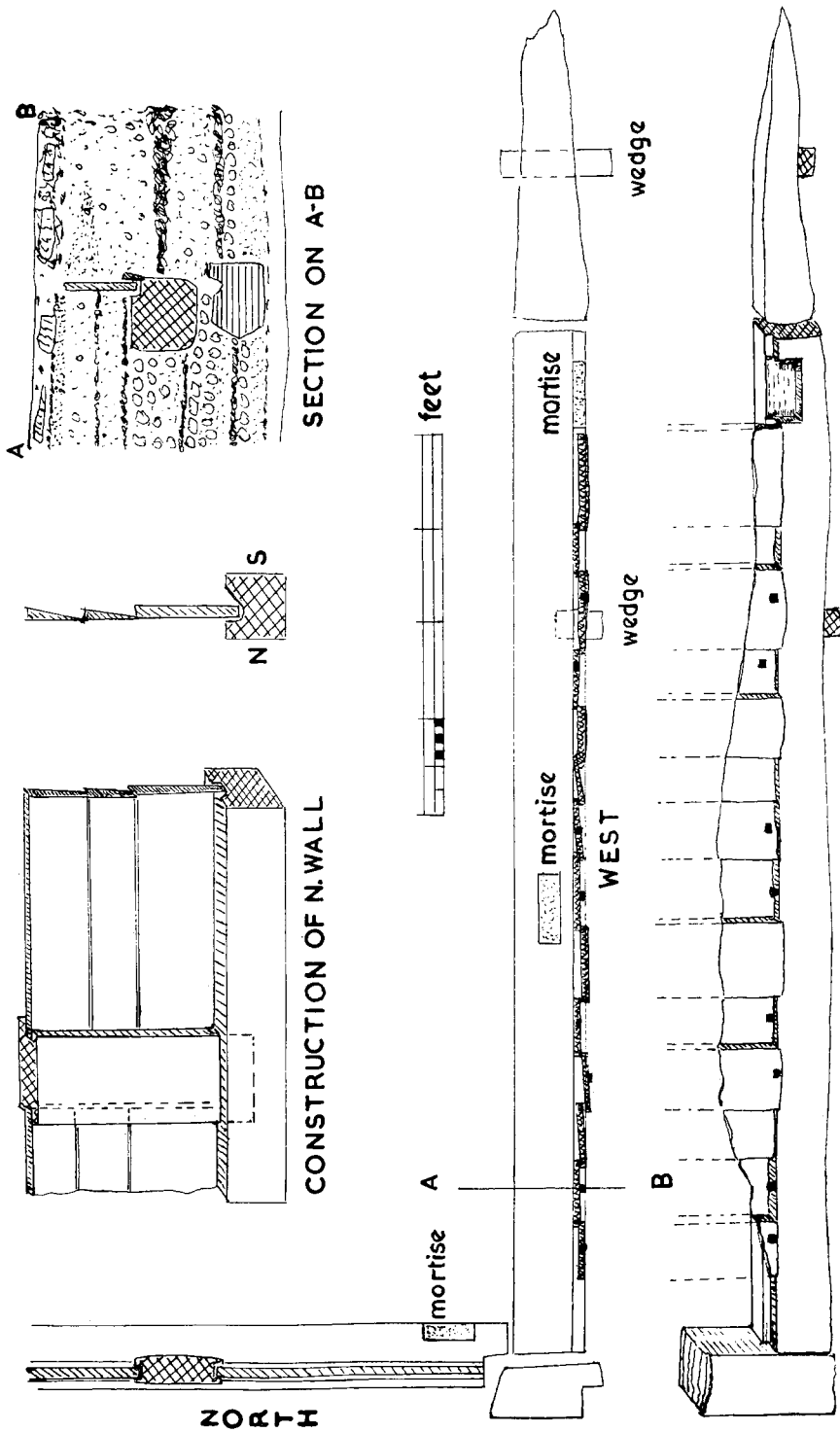

ELEVATION OF W WALL

FIG. 44

WEOLEY CASTLE, BIRMINGHAM
 Details of construction of walls of wooden building (p. 116)

Rights have not yet been granted to use this image in electronic media. Please refer to printed article.

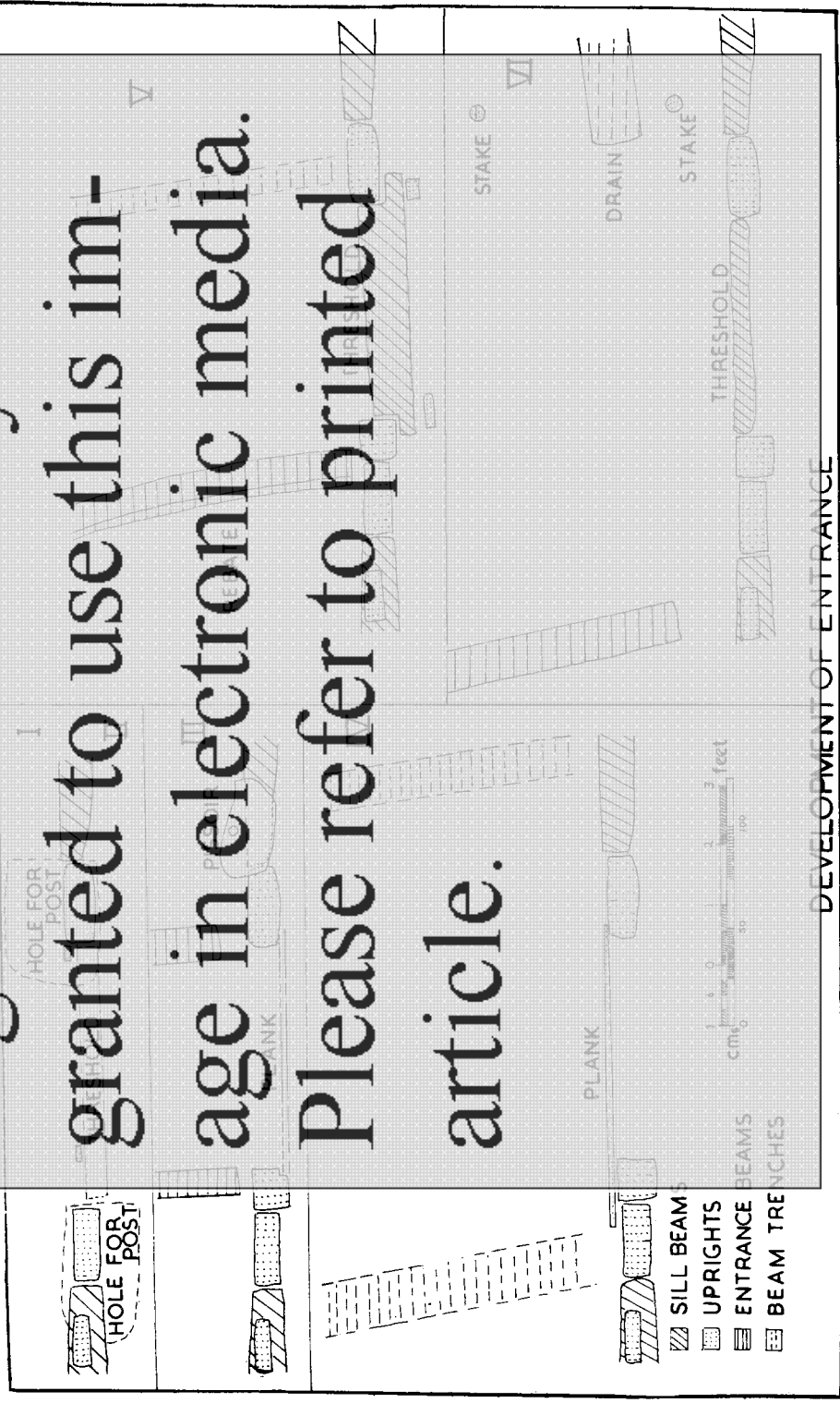

FIG. 45
 WEOLEY CASTLE, BIRMINGHAM
 Development of entrance of wooden building (pp. 117, 119)

EARLIER STRUCTURES ON THE SITE (FIG. 40)

Apart from the wooden building, the excavation of 1961 showed that the initial stage was a large ditch without a bank; a ditch which was later recut to make a ditch and bank for a palisade. This ditch and bank antedated the stone and wooden buildings we have been discussing and therefore the initial beginning on the site, if the large ditch is indeed the beginning, must be placed perhaps well before 1200.

Timber structures of this early period were found together with pits and hearths. The associated pottery is not particularly characteristic of the twelfth century, but on the other hand there are two stone gorgon-head gargoyles which cannot be later than 1150 at the latest. The evidence, then, as far as it goes, indicates a manor occupied perhaps by 1100, with stone buildings already in use and large timber structures.

Over the whole of the area of the wooden building there were traces of still earlier structures—two pits on the N. and what appeared to be the remains of a big hearth or oven at a considerable depth, about 1 ft. below the level of the earliest period (PL. XVII, c).

DATING

The finds from the building consisted of pottery, some metal objects of interest and two coins relating to it. The coin of Henry III (p. 132; PL. XVIII, c, 2) in the top floor-level of the stone building must mark also the closure of the wooden building, since the two were so intimately connected, as indeed the section showed. A penny of John (p. 132; PL. XVIII, c, 1), minted *c.* 1210, was found in the black layer on the N. side of the wooden building (FIG. 42, *b*, 5-6), which accumulated against the bottom of the building and which corresponds with floor 2. It would seem reasonable, therefore, to allot a life span of perhaps 60 years for this building, from, say, 1200 to 1260. Is this long enough to account for five reconstructions? It hardly seems likely, particularly since most of these floors carried vegetation and hazel nuts on their surface and showed that after each destruction the site lay fallow for a little time before rebuilding. On the other hand, none of the pottery is characteristic of the twelfth century in this area and, therefore, the following dates seem to be the safest ones under the present conditions:

Periods I and II. *c.* 1200-1230.

Periods III, IV, V and VI. *c.* 1230-1260.

COMPARISONS WITH SIMILAR STRUCTURES ELSEWHERE

The use of weather-boarding in this building was a complete surprise in an area where the oldest buildings have an infilling of daub and wattle between timber-framing. However, there are barns in the area of seventeenth-century or early eighteenth-century date where both vertical and horizontal weather-boarding are used, and they may represent a continuance of tradition.

There is an early notice of the use of weather-boarding at Southwark in 1223⁴ and in 1378 a mention of nails for weather-boarding for buildings at Fornsett, Norfolk,⁵ but whether this boarding was vertical or horizontal we do not know.

⁴ L. F. Salzman, *Building in England down to 1540* (1952), p. 244.

⁵ *Ibid.*

For anything like a close comparison on construction we must go to Germany, to the houses found in the ring-moat at the Husterknupp.⁶ House 3, which is of much the same proportions as Weoley but which is at least 250 years older, had vertical weather-boarding on sill beams. The sill beams dovetailed into upright posts and the weather-boarding, tongued and grooved, fitted into central slots in the sill beams. On the whole it was a much more rigid structure than Weoley, where the sill beams merely abutted against the posts, which in any case were flat-bottomed and rammed and not pointed. The arrangement of the vertical weather-boarding pegged into a rebate suggests an easier and better method than that employed at the Husterknupp. Somewhat similar boarding and pegging occurs in the church at Stock, Essex, and a continuation of the tradition may be noted in Monmouthshire in the stud and panel work of medieval houses.⁷

Horizontal weather-boarding was used on the houses of the Stellerburg of the ninth and tenth centuries.⁸ Here, however, it was tongued and grooved, but it was set into the uprights and sill beams in exactly the same manner as at Weoley. The sill beams were dovetailed as at the Husterknupp. Another parallel is to be found at Burgdorf in Saxony in the eighth and ninth centuries.⁹ It is interesting that at the Stellerburg, as at Weoley, both vertical and horizontal weather-boarding occur. Whether the two forms represent two building traditions from different areas is a matter yet to be resolved clearly.

There are obvious affinities with Scandinavian stave building, but the arrangement of both vertical and horizontal weather-boarding differs, particularly with regard to the lack of tongued and grooved work. The intermediate mortised uprights between the horizontal boards also seem to have no parallel. The non-mortised sills and corner-posts are intermediate in classification between the mortised sills and plain upright planking in the ground. The arrangement seems to occur in the Norwegian stave churches in the latter part of the twelfth century.¹⁰

POTTERY

The pottery here described is in the main from the floor-levels of the wooden building or from the levels outside which have a definite correlation with those within. Pottery was scarce inside the building except in the room at the W. end, but was more plentiful outside. Fragments from outside levels fitted in some cases those from inside even where the distance apart was as much as 50 feet.¹¹

With regard to frequency of the ware, certain conclusions are possible. First, the recurved rims of the cooking-pots (nos. 3 and 4) grew markedly less as the thirteenth century progressed. On the other hand, the exaggerated recurved rim (no. 14) continues throughout the period; the same may be said of glaze (green, yellow and orange) and thumb-pressed bases. The hard grey ware (nos. 29-34) seems to fall just within the period covered, being markedly less frequent in period II. The recurved bowls (no. 26), fine

⁶ A. Herrbrodt, *Der Husterknupp, eine niederrheinische Burganlage des frühen Mittelalters* (1958), pp. 25-40.

⁷ Sir C. Fox and Lord Raglan, *Monmouthshire Houses* (1951), figs. 2 and 11.

⁸ F. Saestel, 'Die Stellerburg und Wikingerzeitliche Zimmermannskunft,' *Mannus*, 1939, p. 29 ff.

⁹ H. Schroller, 'Beiträge zum urgeschichtlichen Hausbau in Niedersachsen,' *Mannus*, 1934, p. 68 ff.

¹⁰ A. Bugge, 'Origin, development and decline of the Norwegian stave church,' *Acta Archaeologica*, vi, fasc. 1-2 (1935), 152 ff.; *Der Husterknupp*, fig. 78.

¹¹ For the pottery from the stone building see *op. cit.* in note 2, pp. 71 ff.

red-glazed ware (no. 35) and the Deritend ware (no. 21) begin *c.* 1230. The characteristic wavy-line pottery (nos. 16-20) dies out by this same date. Convex bases were the rule except where shown.

POTTERY ANTEDATING THE BUILDING FROM THE CLOSE VICINITY (FIG. 46)

1. Buff grey with large white grits, medium firing. From the sandstone layer (FIG. 42, *a*, 12). Cp. Beere, *Med. Archaeol.*, II (1958), fig. 31, nos. 11, 14, and Wareham castle keep, *id.*, IV (1960), fig. 21, D 18.
2. Medium grey with medium white grits, medium firing. Layer as no. 1. Cp. Beere, *loc. cit. s.v.* no. 1, and White castle, *Antiq. J.*, xv (1935), 320 ff., fig. 4, no. 19.

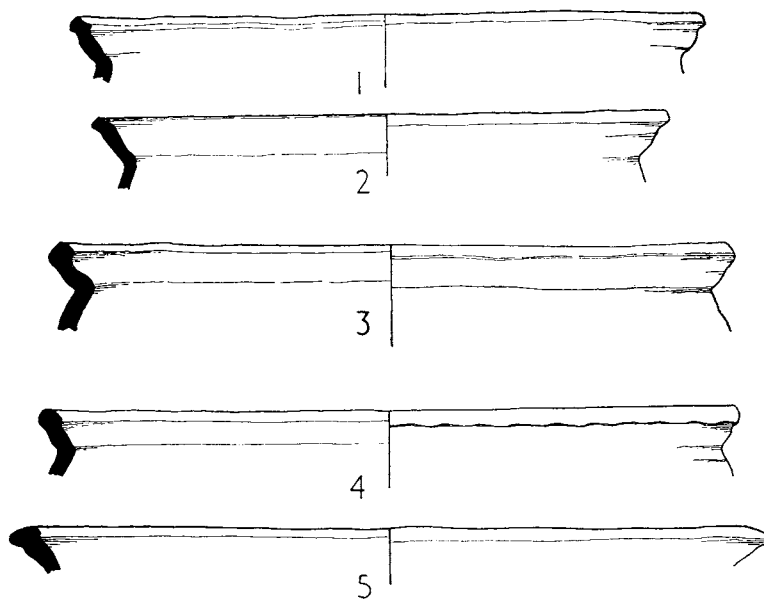

FIG. 46

WEOLEY CASTLE, BIRMINGHAM

Pottery antedating wooden building (p. 122). Sc. $\frac{1}{4}$

Copyright Birmingham City Museum

3. Buff grey, large white grits, medium firing. From the top of the early bank. Cp. Whittington court Roman villa, *Trans. Bristol and Gloucesters. Archaeol. Soc.*, LXXI (1952), fig. 7, no. 39.
4. Dark blue grey, medium white grits, well fired. Finger-pressing on rim. From the matrix of the early bank. Cp. Wareham castle keep, *loc. cit. s.v.* no. 1, D 26, Ascot Doilly, *Antiq. J.*, xxxix (1959), 219 ff., fig. 9, c 1 and White castle, *loc. cit. s.v.* no. 2, no. 20.
5. Light buff grey, fine black grits, well fired. Layer as no. 4. Cp. Ascot Doilly, *loc. cit. s.v.* no. 4, D 10, and City defences, New College, Oxford, *Oxoniensia*, xvi (1951), fig. 15, no. 3.

All the above sherds have twelfth-century affinities. No. 4 is the only stratified sherd from Weoley castle with finger-pressing. The group as a whole is not likely to be earlier than the middle of the century.

POTTERY FROM BUILDING AND CLOSE VICINITY, c. 1200-1230

Floors 1 and 2 (FIG. 47)

6. Dark blue grey, fine black grits, well fired, floor 1. Cp. no. 5.
7. Buff, fine black grits, well fired, with sparse olive-green glaze on interior, floor 2. Similar specimens of the same period fitted with spouts, with orange and yellow glaze on interior, were recovered from the E. side of the stone building (Cp. *op. cit.* in note 2, p. 73, fig. 7). Cp. also Hungate, York, *Archaeol. J.*, cxvi (1959), fig. 23, nos. 17 and 18, ascribed to the twelfth century.
8. Blue black with friable surface, fine white grits, lightly fired, floor 2. A vessel which seems to have been made on a slow wheel, resembling in texture many pagan Saxon pots.
9. Blue black, fine white grits, medium fired. Found in equivalent levels outside the building with coin of John (p. 122; PL. XVIII, c, 1).

Floor 3. c. 1230-40 (FIGS. 47-48)

10. Dark blue grey with white grits, medium firing, floors 3 and 4. Cp. White castle, *loc. cit. s.v.* no. 2, no. 18.
11. Dark blue grey, fine white grits, medium firing. For shape cp. R. J. Sherlock, 'Excavations at Deritend,' *Trans. Birmingham Archaeol. Soc.*, LXXIII (1955), fig. 2, no. 7.
12. Blue black with fine black grits, medium firing, with purplish brown interior. For shape cp. City defences, New College, Oxford, *loc. cit. s.v.* no. 5, fig. 15, no. 15.
13. Dark blue grey, large white grits, medium firing.
14. Grey buff, with large white grits, well fired. Similar vessels from periods II and III of the stone building. Cp. D. Sturdy, 'Pottery from Clarendon hotel, Oxford,' *Oxoniensia*, xxiv (1959), fig. 8, no. 1.
15. Blue grey, well fired with small white grits. Cp. E. M. Jope, 'Mediaeval pottery in Berkshire,' *Berks. Archaeol. J.*, I (1947), fig. 5, no. 2, and Hawkesley farm, *Trans. Birmingham Archaeol. Soc.*, LXXVI (1958), fig. 7, no. 14.
- 16-20. Group of vessels with characteristic incised wavy-line decoration. This appears to be a local fabric, very friable, varying in colour from blue to red, containing large white grits. No. 19 from floor 2, nos. 16, 18 and 20 from black layer outside building (FIG. 42, b, 6/5) with coin of John (p. 122; PL. XVIII, c, 1), no. 17 from below the level of the earliest building. A local comparison occurs at Hawkesley farm, *loc. cit. s.v.* no. 15, fig. 6, no. 3. These were not found above floor 2 and one was earlier than c. 1230.

Floor 4. c. 1240-1250 (FIG. 49)

21. Medium grey, well levigated, thin ware with fine black grits, extremely hard firing. The ware closely approximates to that of nos. 29-34. One fragment from the corridor N. of the wooden building. Handle as Deritend, *loc. cit. s.v.* no. 11, fig. 2, no. 21. No glaze, but similar glazed handles occurred in this level and those above. Cp. also Deritend, *loc. cit. s.v.* no. 11, p. 110, and Brandon castle, *Trans. Birmingham Archaeol. Soc.*, LXXIII (1955), 80, fig. 10, no. 2.
22. Blue grey, fine white grits, well fired. Thin fabric. Cp. Shareshill, *Trans. Birmingham Archaeol. Soc.*, LXXVII (1959), fig. 8, no. 9.

Floor 5. c. 1250-1260 (FIG. 49)

23. Reddish orange, fine black grits, well fired. The concave rim and colour of this ware are characteristic, and it was only found on floors 5 and 6 and associated levels.

Floor 6. c. 1250-1270 (FIG. 49)

24. Reddish orange, medium white grits, well fired.
25. Blue grey, large white grits, well fired.
26. Thin grey ware, well levigated and hard fired. Three of these incurved-rim bowls were found in levels near those equating with floor 4.

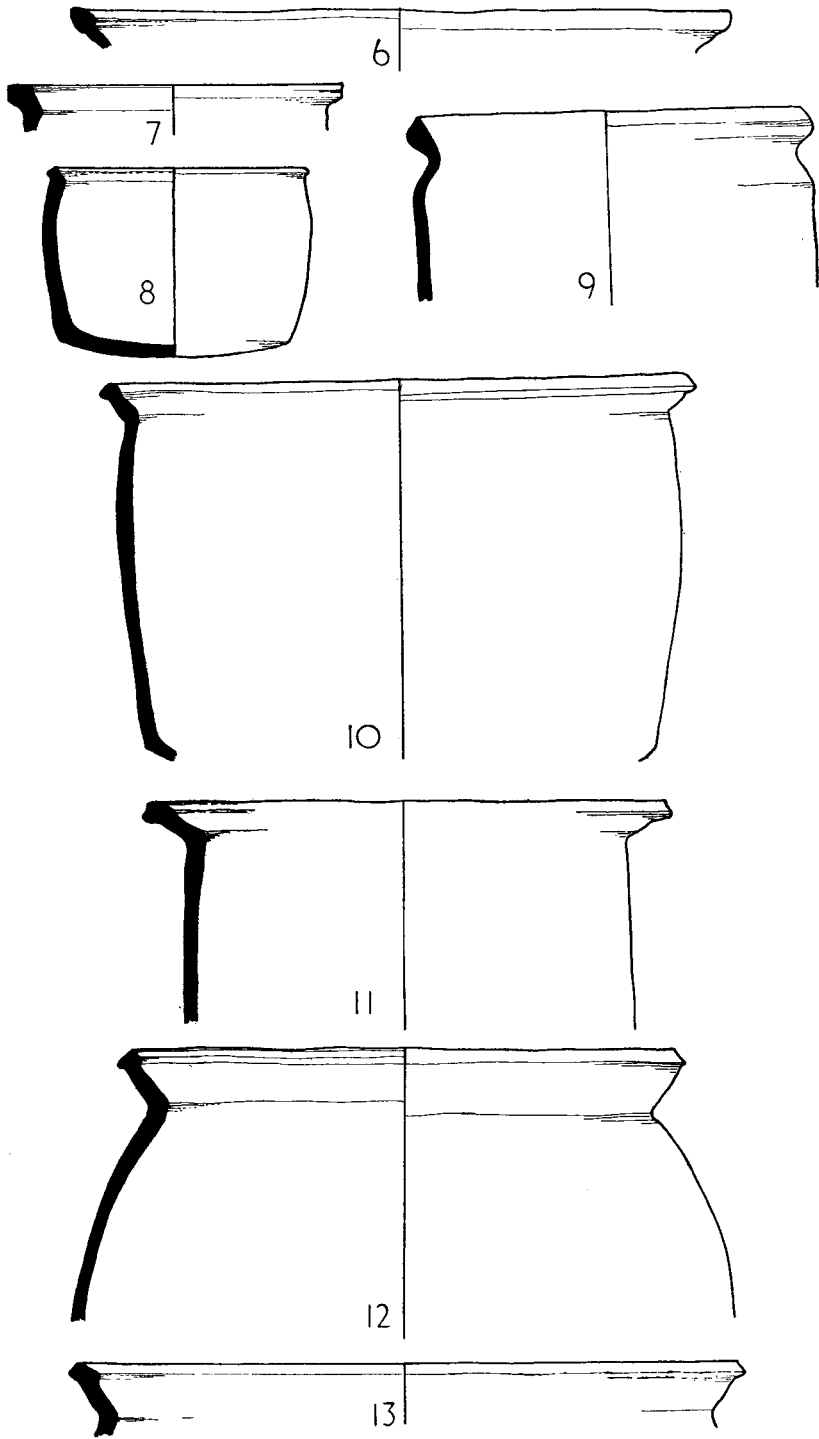

FIG. 47

WEOLEY CASTLE, BIRMINGHAM

Pottery from wooden building, c. 1200-1230 (pp. 117, 125). Sc. $\frac{1}{4}$

Copyright Birmingham City Museum

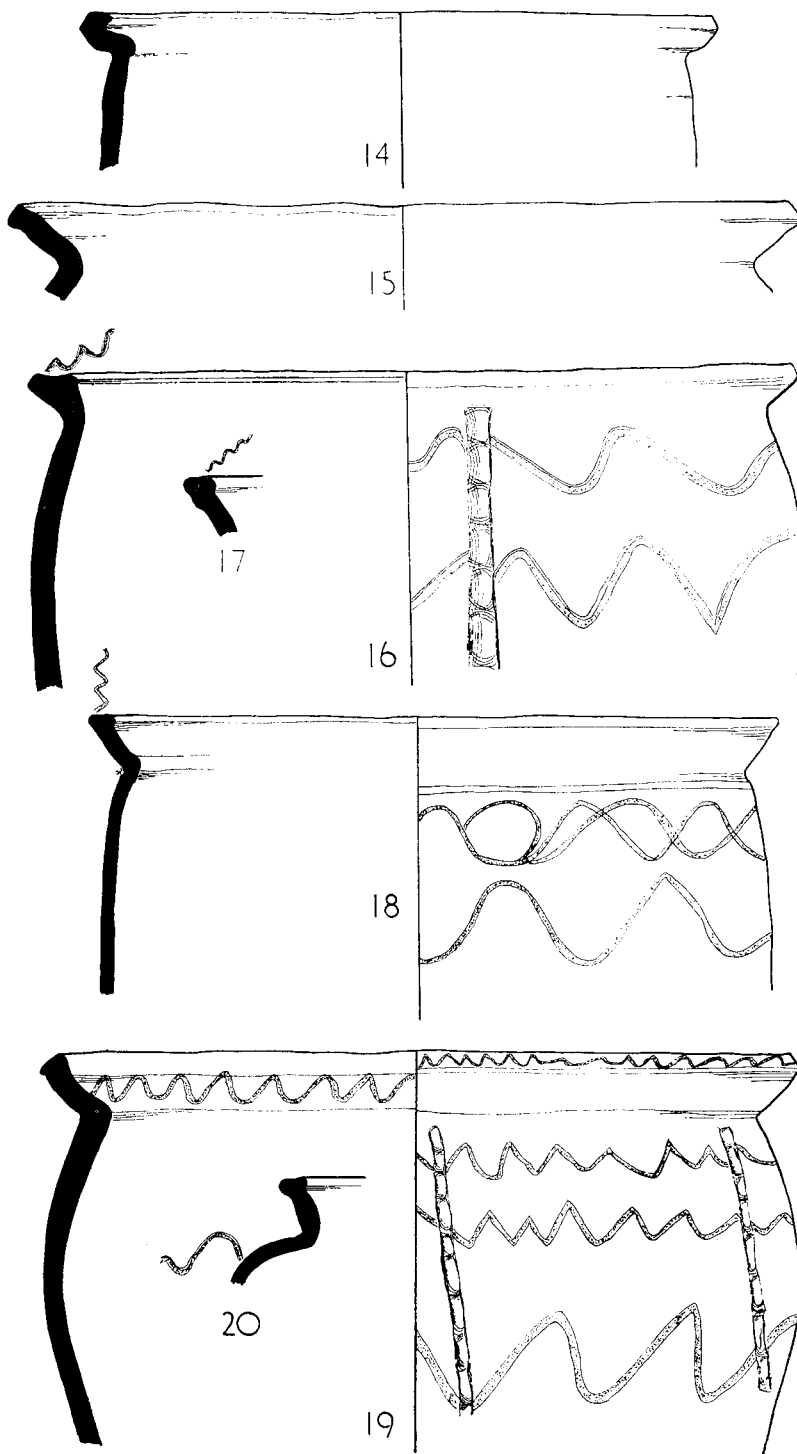

FIG. 48

WEOLEY CASTLE, BIRMINGHAM

Pottery from wooden building c. 1200-1230 (pp. 117, 125). Sc. $\frac{1}{4}$

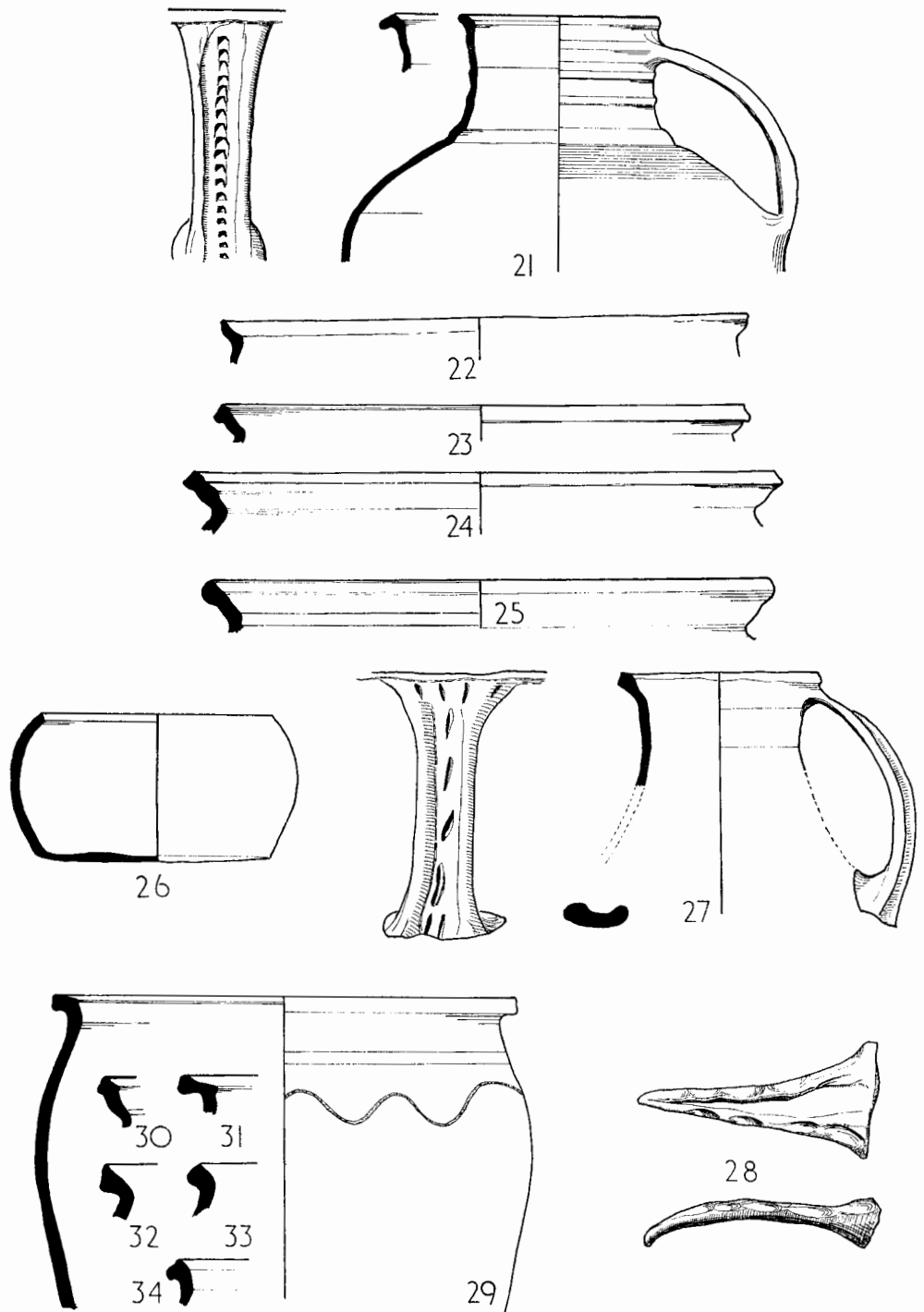

FIG. 49

WEOLEY CASTLE, BIRMINGHAM

Pottery from wooden building, c. 1230-70 (pp. 117, 119, 125, 129). Sc. $\frac{1}{4}$

Copyright Birmingham City Museum

27. Buff red ware, slightly gritty surface, well fired. Dark apple-green glaze. Top black level N. of wooden building. For shape cp. White castle *loc. cit. s.v.* no. 2, no. 15.
28. Hard grey ware with small white grits and pinched decoration. Skillet handle. From floor 6 and top black levels W. of wooden building. Cp. Deritend, *loc. cit. s.v.* no. 11, no. 24, and Audlem kilns, *Med. Archaeol.*, IV (1960), fig. 40, nos. 15 and 16.

Various Levels (FIGS. 49-50)

- 29-34. A group of hard grey ware, well fired and levigated, varying in colour from dark blue through grey to buff. The ware occurs in all levels but sparsely in the period before the earliest building, when the colour is usually buff. It compares closely in texture with the earlier group at Deritend, *op. cit. s.v.* no. 11, pp. 109-10, and is extremely well finished. Cp. for shapes Selsley Common, *Trans. Bristol and Gloucesters. Archaeol. Soc.*, LXVIII (1949), 30 f., figs. 2 and 3.
29. Floors 4 and 5 and top and middle black layers in vicinity of wooden building. Periods II and III of stone building. Cp. Hungate, York, *op. cit. s.v.* no. 7, c ware, p. 76, fig. 16, nos. 28 and 29.
30. Floors 4 and 5. Cp. Deritend, *loc. cit. s.v.* no. 11, no. 2.
31. Floor 3. Cp. Clarendon hotel, Oxford, *Oxoniensia*, XXIII (1958), fig. 18, z 16.
32. Floor 2. Cp. *loc. cit. s.v.* no. 31, z 14; Deritend, *loc. cit. s.v.* no. 11, no. 5.
33. Bottom black layer N. of wooden building with coin of John (p. 122; PL. XVIII, c, 1). Cp. Deritend, *loc. cit. s.v.* no. 11, no. 1.
34. Layer as no. 33.
35. Fine red ware, well fired vertical bands of dark red glaze flanked by raised cream slip strips alternating with bands of raised cream slip leaves on a yellow glazed ground. Floor 6. This is a sister vessel to one discovered (PL. XVIII, A, 1; and *op. cit.* in note 2, p. 75, fig. 2) in the robbed wall of the stone building which presumably dates between 1264-1280 (licence to crenellate and completion of Roger de Somery's building). The technique occurs in the Oxford region, rouletting along the strips being a feature, and painting is also known in the same area. Cp. Jope, *op. cit. s.v.* no. 15, fig. 7, nos. 1, 2 and 3. Similar jugs also occur in London. At Weoley they appear to be firmly dated c. 1250-1280.

POTTERY LATER THAN THE BUILDING (FIG. 50 and cp. PL. XVIII, A, 2)

36. Fine buff ware with reddish surface. Streaky apple-green glaze with, probably, gutter spout. From the bottom ash layer above the dump of the moat over the wooden building (FIG. 42, a, 1). Cp. Ascot Doilly, *op. cit. s.v.* no. 4, fig. 19, κ 1, White castle, *loc. cit. s.v.* no. 2, nos. 13 and 17, and E. M. Jope, 'Late 12th-century well at St. John's College, Oxford,' *Oxoniensia*, xv (1950), fig. 17, no. 4.

SMALL FINDS (FIG. 51)

FROM LEVELS EARLIER THAN THE BUILDING

1. Portion of barrel padlock-case, bronze. Cp. *Antiq. J.*, VIII (1928), 524.
3. Handle, iron, coated with silver on the under side. Mount for a crook (?).
24. Punch or nail, iron.
25. Square-headed nail.

FROM THE BUILDING LEVELS

Periods I and II. c. 1200-1230

2. Top of barrel padlock. Cp. Hungate, York, *Archaeol. J.*, cxvi (1959), fig. 18, no. 4, where there is a full discussion of method of working and parallels, and Lydney castle, *Antiq. J.*, xi (1931), pl. xxxv, fig. 2. The present example has elaborate fretwork decoration.
4. Iron shears with silver inlay. *London Museum Med. Catal.* (1940), p. 159, fig. 47, type 1b.

5. Iron pick with birch handle. Floor 1. *Op. cit. s.v.* no. 4, p. 126 and Lydney castle, *op. cit. s.v.* no. 2, pl. xxxv, fig. 7.
6. Spindle-whorl of stone (soft slate). Floor 2.
7. Staple, iron (several examples).
8. Strip, bronze, with punched decoration. Slightly thicker on top edge by $\frac{1}{64}$ in. Top edge smoothed and filed. Possibly a decorative top for leather or wooden bottle. For a discussion on bronze strip see E. M. Jope, '12th-century castle at Ascot Doilly,' *Antiq. J.*, xxxix (1959), 267.
9. Iron ring with traces of silvering on exterior.

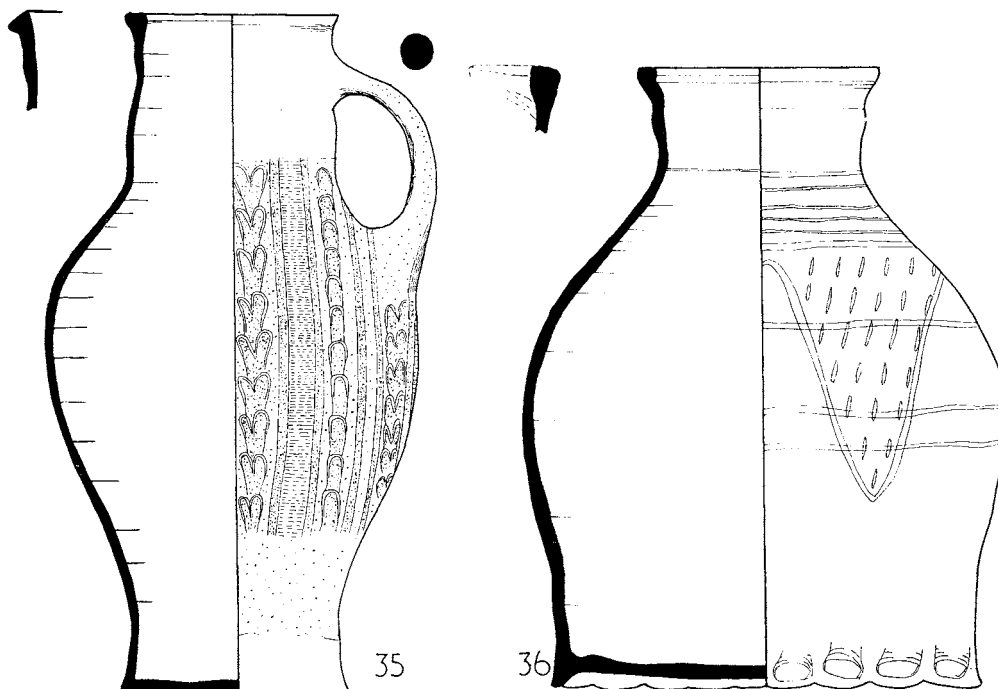

FIG. 50

WEOLEY CASTLE, BIRMINGHAM

Pottery from wooden building, c. 1270-80 (p. 129). Sc. $\frac{1}{4}$

Copyright Birmingham City Museum

10. Base of wooden bowl: ash (*fraxinus excelsior*).
12. Handle of antler horn.
22. Fragment of wooden bowl: oak.
26. Nail, iron. Floor 2.
28. Nail, iron.
31. Netting needle, bronze.

Period III, c. 1230-1270

11. Handle of chest, iron. Floor 3.
13. Horseshoe, iron. Outside levels corresponding to floors 4, 5 and 6.
14. Horseshoe, iron, with countersunk round holes and wavy edge. Floor 3. *Op. cit. s.v.* no. 4, pp. 114-5.
15. Part of hinge, iron. Levels as no. 13.

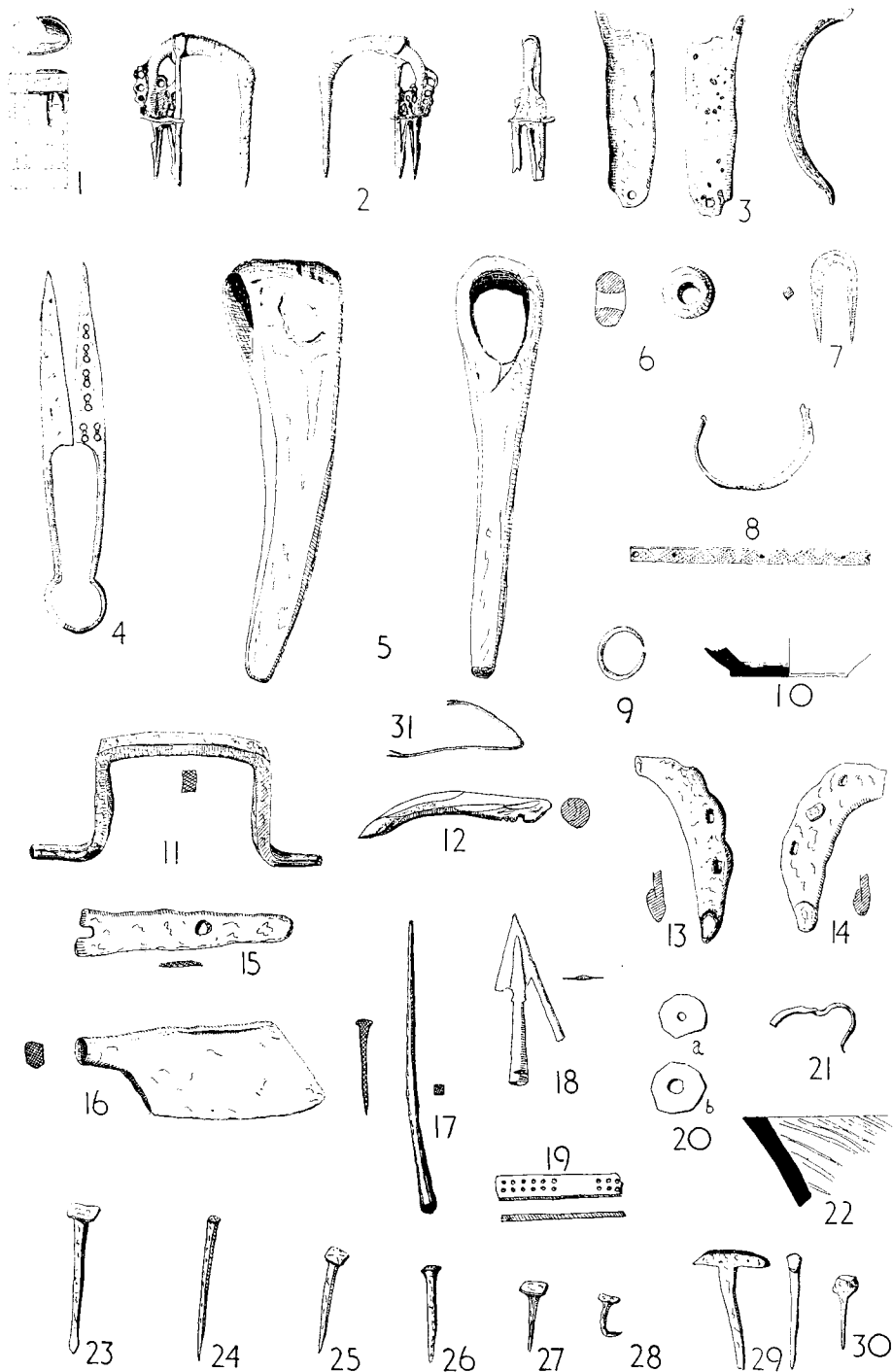

FIG. 51

WEOLEY CASTLE, BIRMINGHAM

Objects of metal, stone, wood, horn and leather (pp. 129 ff.). Sc. $\frac{1}{4}$

Copyright Birmingham City Museum

16. Chopper, iron. Top edge flattened by hammering. Levels as no. 13.
17. Arrowhead, iron. Levels as no. 13. *Op. cit. s.v.* no. 4, p. 66, fig. 16, type 7. For a hoard of these arrowheads see Brandon castle, *Trans. Birmingham Archaeol. Soc.*, LXXIII (1955), pl. 7.
18. Arrowhead, iron, with slight wings in shaft. Floor 6. *Op. cit. s.v.* no. 4, p. 66, fig. 16, type 15.
19. Punched leather strap. Floor 5.
- 20a & b. Cut leather washers. Floor 4.
21. Leather lace. Floor 5.
23. Nail, iron, with spatulate blade. See Ascot Doilly, *op. cit. s.v.* no. 8, fig. 20, no. 10. Levels as no. 13.
27. Square-headed nail, iron. Levels as no. 13.
29. Nail, iron. Levels as no. 13.
30. Horseshoe nail, iron. Levels as no. 13. Cp. Ascot Doilly, *op. cit. s.v.* no. 8, fig. 20, no. 6.

SHOES (FIG. 52)

Fragments of nine shoes were found but the two illustrated are the only ones with traces of upper remaining; both belong to *c.* 1220 and bear comparison with those from the Clarendon hotel, Oxford, *Oxoniensia*, xxiii (1958), 75-7.

1. A small man's shoe for the left foot about size 4½. Floor 1. Interior repairs of heel and sole, rough stitch right through. Flesh side interior of sole and upper.
2. Man's shoe size 6, left foot, appearing as a slipper. Sole and heel repairs and interior wooden sole. The upper appears to be a repair sewn over the remnant of the earlier upper at the toe cap. The heel has been moulded from a hollow. Stitching was by thread.

COINS (PL. XVIII, C)

By R. H. M. Dolley

Lecturer in Medieval History, Queen's University, Belfast

1. *Obv.* **hENRICVS R EX;** ; *Rev.* **+ RAVR·ON·LVND.**

Weight (uncleaned) 22·81 grains, die-axis *c.* 90°

Short Cross penny of John (type of Henry II) of Lawrence class vc by the London moneyer Rauf. The dies for this issue were certainly in production by 1208, and possibly a year or two earlier, but 1208 can be taken as a secure *terminus post quem* for the layer dated by the coin. How long class vc continued in production is not clear, but it certainly was not much after 1210, and of course the coins were not demonetized until 1247—though then very effectively. Even so, however, the condition of the coin might be thought most consistent with its having been lost during the second decade of the thirteenth century. From black layer between nos. 5 and 6, FIG. 42, b.

2. *Obv.* ***hE [NRICVSR]EX·III'** ; *Rev.* **IOH | OHS | [ADM | VND]**

Weight (uncleaned) 9·26 grains, die-axis *c.* 315°

Cut halfpenny of the so-called *Long Cross* issue of Henry III by the Bury St. Edmunds moneyer John. Sufficient of the obverse type is visible for the coin to be given with confidence to Lawrence classes IIIa or IIIb, and the absence of ligation between the O and N of the copulative in the reverse legend suggests class IIIa. Class III is believed to have been introduced late in 1248, and this year must be considered an absolute *terminus post quem* for a layer dated by the coin. An absolute *terminus ante quem* is provided by the extremely effective demonetization of the *Long Cross* issue in 1279, but the condition of

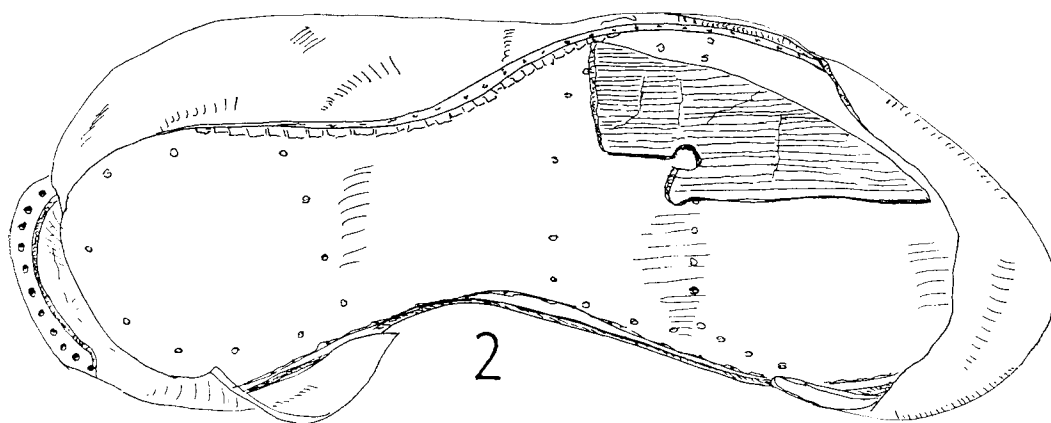
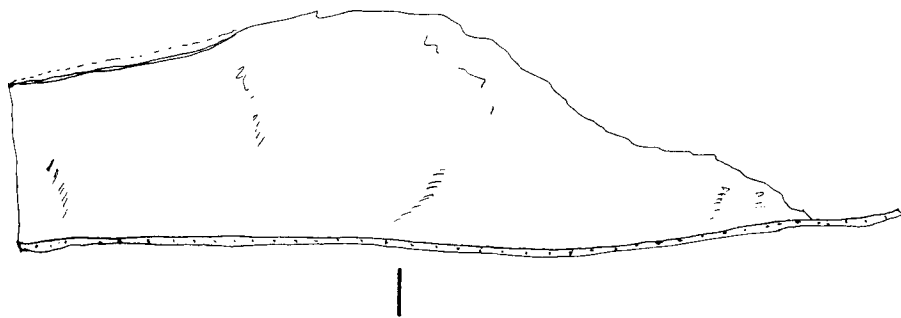
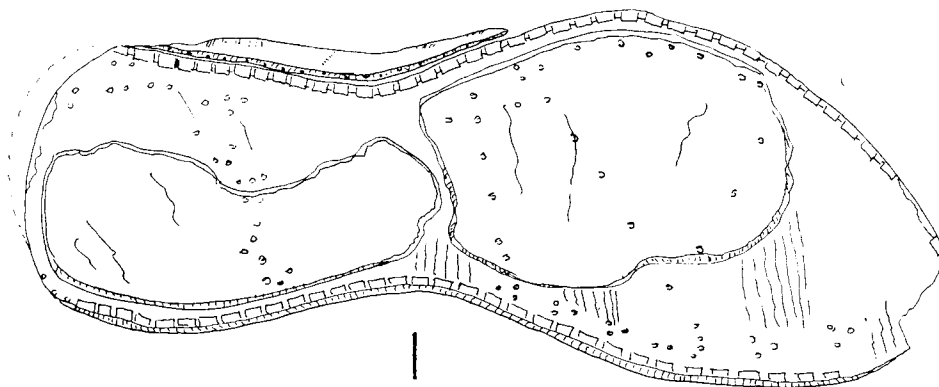

FIG. 52
WEOLEY CASTLE, BIRMINGHAM
Leather shoes from wooden building, c. 1200-1230 (p. 132). Sc. $\frac{1}{2}$

Copyright Birmingham City Museum

the cut halfpenny may seem to indicate loss within a very few years of its being put in issue. From top floor of stone building.

FLIES

By Professor F. W. Shotton

Department of Geology, University of Birmingham

Flies found in top black deposit outside the building were first identified by Mr. K. G. V. Smith (Oxford University) as pupae of *Muscinae* (Deptervus flies) near *Stomoxys* and *Heamatobia*. Mr. P. J. Osborne of this department later examined the mummified flies inside the pupae, after swelling them in tribasic sodium phosphate. They are almost certainly *Stomoxys calcitrans* Linn (the Stable Fly or Biting House Fly). 'Sucks the blood of warm-blooded animals such as horses, cattle, dogs, cats, chickens and occasionally human beings; . . . the larvae . . . develop on straw, hay and other debris impregnated with animal excretions, such as stable litter. Sometimes old decaying hay or straw alone is chosen, or horse manure, but never cattle dung. Pupation takes place in drier parts of the habitat or in the ground': C. N. Colyer & C. O. Hammond, *Flies of the British Isles* (1951), pp. 301-2.

NOTE

The Society is much indebted to the City of Birmingham Museum and Art Gallery for a grant towards the cost of publishing this paper.