

The Samian Ware by G C Boon¹

The material published is arranged according to Phases and levels. There is little ware of note, and it is sufficient to only publish a range of the decorated ware, omitting nondescript and unstratified material, and all plain ware (which occurred in the usual forms and frequency) except for three stamped pieces (nos. 18-20), for details of which I am thankful to Mr B R Hartley. Although unstratified an unusual dish is included (no. 21).

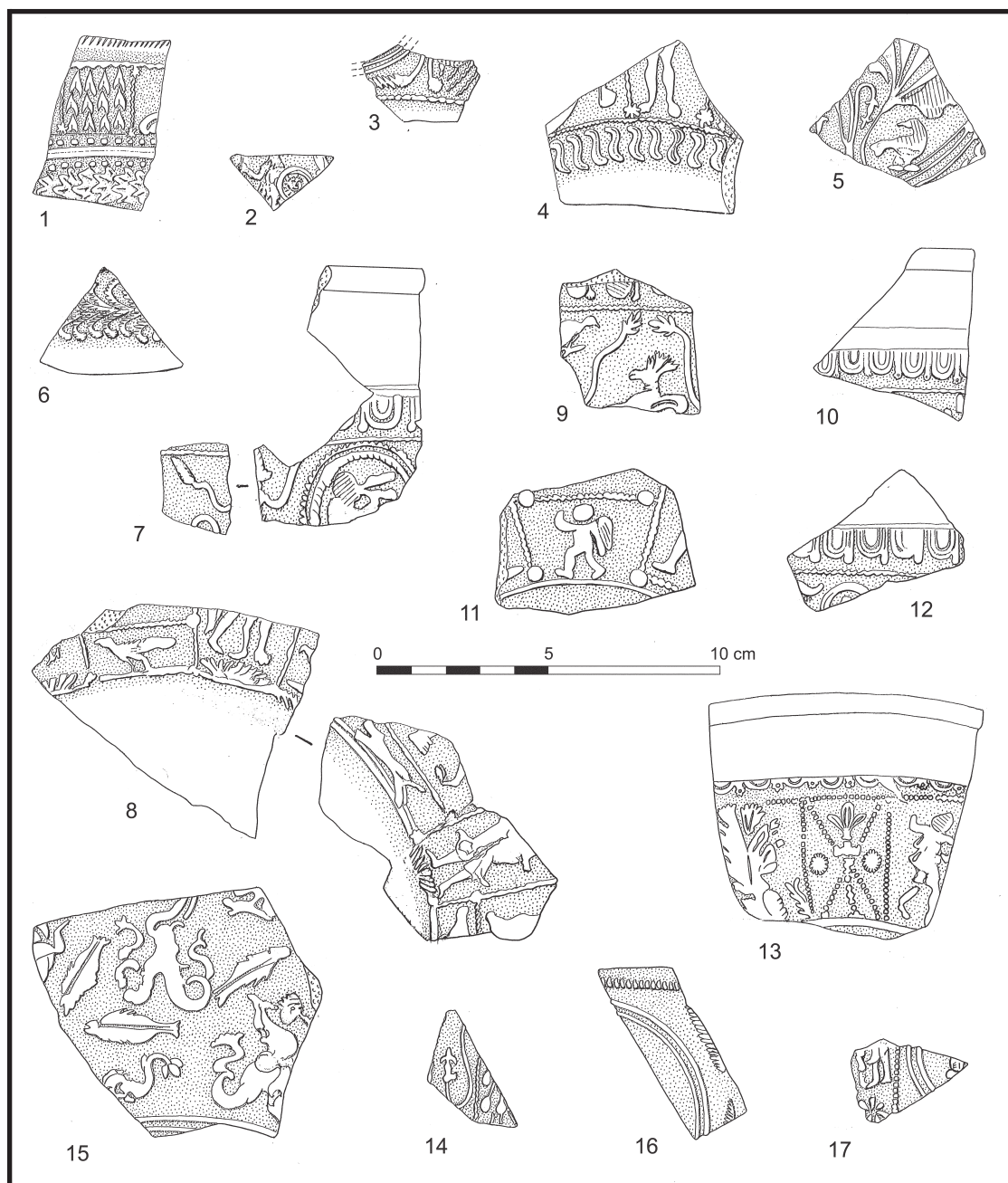

Fig. 32: Decorated samian ware

¹ This report was written after the excavations were completed and not revised in 1996.

Phase I (No samian).*Phase II* (All Flavian).

- 1 Dr. 29. Upper zone with imbrication and the fore-legs of an animal in the panel to R. Lower zone delimited by a wreath of palmate leaves cf. Knorr 1919, Taf. 44G; Oswald 1931, pl. X.12, Jucundus. Vespasianic, cf. Atkinson 1914, pl. V.21. (D7).

Phase III

(Much residual Flavian, some later, down to late Antonine. Plain ware of Hadrianic-Antonine and Antonine date well in evidence).

- 2 Dr.37, a small, thin piece which is the earliest decorated sherd in the series, showing part of Minerva, O.131A. Style of Germanus of La Graufesenque, cf. Knorr 1912, Taf. XI.4. Neronian-Vespasianic. (D6).
- 3 Dr. 37, panel and medallion design; the tendril, cf. Knorr 1919, Taf. 64N, Passienus; Vanderhoeven 1978, Taf. 83.675. Vespasianic. (D6).
- 4 Dr. 37, basal. The standing figure is uncertain. The reversed S-godroons of the wreath are occasionally met, e.g. Vanderhoeven 1978, Taf. 83.675; James 1978, 86, fig. 10.13; Karnitsch 1959, Taf. 16.3-4. Karnitsch proposed 'Style of Mercato' of La Graufesenque, Flavian. (D6).
- 5 Dr. 37, with part of an all-over undulating scroll design, using the big palmate leaf, a Germanus original (Knorr 1919, Taf. 35.52); for the general style cf. Hermet 1934, pl. 81.7; Vanderhoeven 1978, Taf. 82.672. Might well be Mercato; cf. Knorr 1952, Taf. 53E. Flavian. (D6).
- 6 Dr. 37, burnt basal wreath fragment, style of Drusus I of Les Martres-de-Veyre, cf. Stanfield and Simpson 1958, pl. 13.168 etc. About AD 100-120. (D6).
- 7 Dr. 37, with distinctive large ovolo of L. Cosius of La Graufesenque; the Satyr is a Germanus original, O.609, here much remoulded: cf. Jacobs 1912, Taf. IV.23, with the same ovolo and similar cross as here on the L. The double arch appears as a wreath or swag there. Cf. Karnitsch 1959, Taf. 25.34. The accompanying shard (excavated at Caerleon in 1962) with the same ovolo shows the structure of the arch and a very similar cross motif which enables the small burnt fragment to be brought in; the stag is not in O., cf. Karnitsch 1959, Taf. 23.8 or 30.2. Late

Flavian or Trajan-Hadrianic.

- 8 Dr. 37, basal fragments of metope décor with notably O.121 and O.333, the Diana and Venus with Handmaiden (these occur together on a Dr. 37 from 1954 excavations at Caerleon). The birds, nondescript dog, and tufts, together with the (base of a) column, are favourite types in late South Gaulish ware. The hind leg of a rearing quadruped has not been identified. Banassac ware of the late Flavian to Trajan-Hadrianic period, cf. Jacobs 1912, Taf. II.13, etc. (D4-5 conj.).
- 9 Dr. 37, late freestyle, inspired by the work of Germanus of La Graufesenque. Neither stag nor bird is in O., but cf. Vanderhoeven 1978, Taf. 87.725, where the stag 'smaller than O.1738' appears. Cf. Jacobs 1912, Taf. II.12. (D4).
- 10 Dr. 37. Late South Gaulish ovolo; cf. Vanderhoeven 1978, Taf. 88.745 for similar. (D4).
- 11 Dr. 37, basal fragment, metopes, with the Cupid, O.435, seen e.g. on the late South Gaulish Dr. 29, Curle 1911, 205, no. 8; Vespasianic-Domitianic. (D4).
- 12 Dr. 37, small. The details – ovolo, Amazon O.2444, made-up tree, etc., Stanfield and Simpson 1958, pl. 81, passim. Style of Acaunissa of Lezoux; the trifold bud in the cross motif is as Rogers 1974, no. G.89. About AD 125-50. (D4).
- 13 Dr. 37, Lezoux ware, mould very worn; ovolo cf. Dore and Gillam 1979, fig. 29.72, on a mould signed bowl of Mercator II, i.e. as Rogers 1974, no. B.180. Horn of Pan-mask to L. below, lightly impressed, not O.214 though lightly impressed. About AD 170-90. (D4).

Phase V (All Flavian)

- 14 Dr. 37, good lustrous ware with poppy-head basal wreath; style of Mommo, as Knorr 1919, Taf. 59, detail 26; Atkinson 1914, pl. XIII.62 gives the Vespasianic date. Cf. Vanderhoeven 1978, Taf. 87.725-7 for other examples. (A2).

Phase VI

(Rubbish-survivals, down to late Antonine).

- 15 Dr. 37. Marine freestyle, with the Tritons O.19 at the top of the fragment, and 21 at lower right; the dolphin, O.2394A, and a fish not in O., but see Stanfield and Simpson 1958, pl. 125.8 in the style of Jullinus. Mr G B Rogers, who most kindly commented on this piece, notes that it also appears on a mould-signed bowl of Servus-iv noted by him. The present style, however, has affinities with the work of Justus of Lezoux, c. AD 150-80, cf. Stanfield and Simpson 1958, pl. III.12.13-4. (E1).
- 16 Dr. 37, with a big double medallion and double twists (sloping to R.) in the spandrels. Style of Cinnamus of Lezoux, thus: cf. Stanfield and Simpson 1958, pl. 158.22. About AD 160-90. (E1).
- 17 Dr. 37. The beaded line is Rogers 1974, 34, no A12, Lastuca and various other potters, about AD 160-90 according to Stanfield and Simpson (1958), but perhaps rather earlier. I have traced neither the rosette without centre, nor the very small double figure-type, with legs on the R. and leg or trophy, etc. on the L. Lezoux ware, Antonine. (E1).

Potters' stamps and graffito on plain ware

- 18 SJEVERI on a Dr. 33, South Gaulish: Mr Hartley notes that this is a stamp of his Severus-ii of La Graufesenque, c. AD 65-95; no other instance of this particular die, however, is on record. (D4).
- 19 REGINI in tabula ansata, on Dr. 18/31, from Lezoux. Mr Hartley identifies this as a 'new' die of his Reginus-iv, c. AD 135-55. The style is quite different from the normal, particularly the ansae, by no means common at Lezoux. (D2).

A section of this bowl is given, together with a drawing of the basal underside, where two graffiti will be seen. That within the base-ring seems merely to have been a spoilt attempt at the other. This may perhaps be read p(anna) or p(atina) xiv (rather than xlv, although that is just possible) – 'dish no. 14' of a set belonging, perhaps, to a particular contubernium, which would certainly have had some vessels in common cf. the graffito ante cocturam, Pe]lveis contub(e)rnio Messoris on a 'mortarium' (Boon and Hassall 1982, 58, no. 44, fig. 6). I cannot cite other examples of pottery vessels numbered in such a way, but two of the surviving cups

in the Plas Uchaf, Abergele deposit of bronzeware (see now RIB II.2 nos. 2415.61-2) – bore scratched numerals, and the bronze skillet from the Museum site at Caerleon (See now RIB II.2 no. 2415.39) also bore a serial number, in that case in punctuate form.

- 20 G.E.N.I.T.O[.R.F.] on Dr. 31, from Lezoux. Mr Hartley's Genitor-ii die 5a; the site-record (including Birdoswald, Catterick, Old Penrith and Piercebridge) and the forms (31,31R) suggests c. AD 155-90. (Unstratified)¹.

Unusual form

- 21 Thickly-potted with deeply undercut rim, and small offset at the wall-base junction. Central Gaulish; compare the Rheinzabern form. Ludowici Tg (Os-wald and Pryce 1920, pl.LX, no.1)². (Unstratified).

1 This example of die 5a by Genitor ii of Lezoux is now listed in the published volumes of the Index of Potters' stamps (Hartley and Dickinson 2009, vol 4, 176). This die appears at Catterick, Birdoswald, Piercebridge and several other sites in the UK and the potter is dated AD 160-200 (Hartley and Dickinson 2009, vol 4, 176-7).

2 Form identification corrected by Dr Monteil.

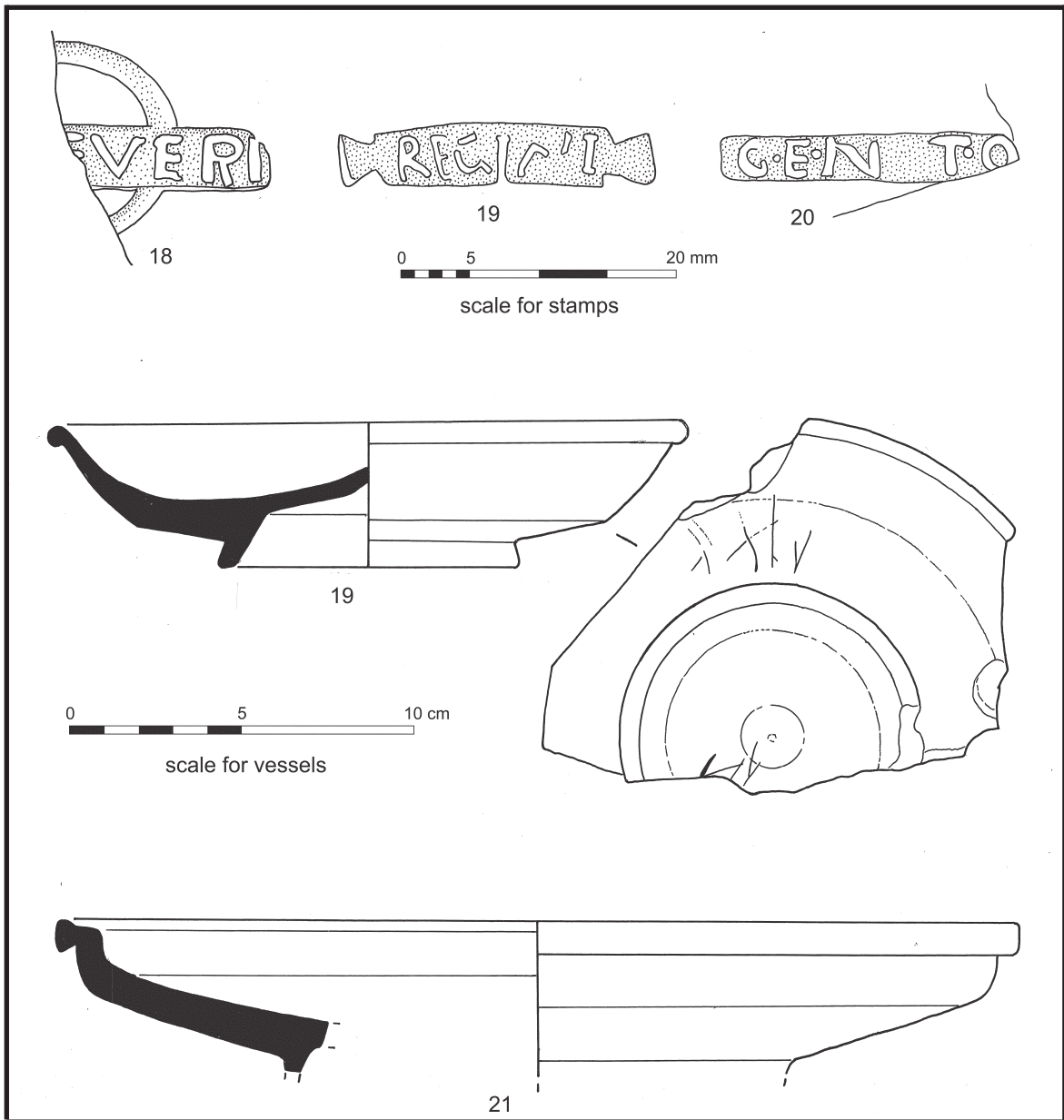

Fig. 33: Plain samian. Stamps, graffito and an unusual plain form