

Chapter 9 : The Pottery

Part 2: The mortaria

Jeremy Evans, Kay Hartley and Phil Mills

with contributions by Yvonne Boutwood

(file name : ChD9mortariaform)

Contents

Mortaria fabrics	9.130
Mortaria form catalogue	9.140

Figure list

Fig. D9.21	Mortaria forms 1-18	9.149
Fig. D9.22	Mortaria forms 19-38	9.150
Fig. D9.23	Mortaria forms 39-61	9.151
Fig. D9.24	Mortaria forms 62-84	9.152
Fig. D9.25	Mortaria forms 85-104	9.153

Chapter 9 : The Pottery

Part 2: The Mortaria

Jeremy Evans, Kay Hartley and Phil Mills
with contributions by Yvonne Boutwood

[Note – the abbreviation P & H used in the mortaria report refers to Hartley, K., 1995, 'Mortaria', in Phillips, D., and Heywood, B., *Excavations at York Minster Volume I. Part 2 The Finds* (London), 304-23.

The serial numbers after the entries were those assigned by KH during her work on the mortaria in the 1980s. These are given on the database in the second column of the table.]

Mortarium fabrics

Yvonne Boutwood and Kay Hartley with additions by J. Evans

Descriptions refer only to the mortaria in the sample, ie other products of same potteries are not included eg early second-century products or other variants of Mancetter-Hartshill potteries etc. Colour references are to the Munsell Soil Colour Chart (1975).

NB. Not all examples are listed after the descriptions.

Fabric 1 Rhineland

Fabric: brownish-pink (5YR 7/6). Inclusions: quartz and sparse orange-brown fragments with occasional soft white calcareous fragments (2mm). Trituration grit: mainly or solely translucent quartz. Serial nos. 411; 526.

Serial no. 384 is a variant of the above fabric, probably produced in the same workshop: very hard, fine-textured, fired to creamy-buff, with thick, well-defined, light red core (Munsell 2.5YR 6/8); the reddish-brown surface colour with buff patches may be a slip, but it was probably intended to be buff-cream. Inclusions: sparse and ill-sorted, transparent quartz (0.5mm); white and pale yellow, rare calcareous fragments (upto 2mm). Trituration grit: mainly or solely quartz (1-2mms).

The rim-profiles of all three mortaria are also notably similar.

Fabric 2 Rhineland

Cream fabric (no Munsell equivalent); self-coloured. Inclusions:, quartz, common sub-angular grains (up to 2 mms) with rare black fragments. Trituration grit: solely translucent and opaque quartz (2-3mms). Serial no. 193

Fabric 3 Rhineland

Hard, white fabric. Inclusions: quartz, common, well-sorted grains and red-brown fragments. Trituration grit: solely fine quartz.

Serial nos:143;191;209;457;480;530)

All: sandpaper grit up to & under bead type

209;457; survive to show deeply corrugated

480 fabric similar but gritting and form differ; poorly made

Fabric 4 Rhineland

Fabric: hard, cream, sometimes with pinkish core. Inclusions: quartz and red-brown fragments (as fabric 3); large fragment of pink feldspar (5mm) and chunks of cream and pinkish-brown hard pottery fragments (up to 5mm) are common. Trituration grit: fine quartz. Serial no. 93

Fabric 5 Rhineland

Fabric: brownish-cream (10YR 8/6). Common inclusions: ill-sorted, transparent pink and white quartz and opaque red-brown fragments, often rounded (2mm). Trituration grit: one or two surviving are as inclusions. Serial nos. 248; 332; 362

Fabric 6 Probably Soller, Kreis Düren, Lower Germany (Tomber and Dore 1998, 79-80) Hard, cream (10YR 8/4) fabric, sometimes with darker core and with hackly fracture. Inclusions: sub-angular, translucent white and pink quartz (1mm), quartz occasionally coated with orange stain, and rare red-brown fragments. Trituration grit: opaque white and translucent quartz (3-4mm), often fired to orange-brown at surface near the spout.

Fabric 7 Oise/Somme region, northern France (Tomber and Dore 1998, 75-76)

Fabric: hard, brownish-cream (2.5YR 8/4); self-coloured. Inclusions: moderate, well-sorted, tiny quartz, occasional red-brown fragments. Trituration grit: opaque quartz and flint inside and on flange. Serial nos. 123; 194; 356; 395; 385 differs slightly.

Fabric 8 Ellingham, Norfolk rather than Colchester (Hartley and Gurney 1997)

Fabric: greenish-cream (5YR 8/3); self-coloured. Inclusions: translucent and white quartz, red-brown and tiny black fragments. Trituration grit: none survives. Serial no: 458;

Fabric 9 Probably Brampton, Norfolk

Fabric: cream with brown iron staining; self-coloured. Inclusions: abundant, ill-sorted quartz, sparse, black fragments. Trituration grit: none survives, but some quartz and flint fragments (1-2mm) on surface of flange. (Serial no 461)

Serial no. 382 is likely to be from Brampton or some other source in Norfolk. The fabric is finer textured with tiny quartz and red-brown inclusions.

Fabric 10 Lower Nene valley

Fabric: hard, fine-textured, greyish-cream; it occasionally has a pink or orangy core; it is sometimes fired to pink near the surface with greyish-white core or can be fired to pink throughout. The mortaria usually have a slip which may be self-coloured, buff or orange-brown. Inclusions: moderate to sparse, quartz, red-brown fragments and occasional black material. Trituration grit: entirely black slag. Serial Nos: 11; 12; 60; 241 has fairly frequent inclusions and an unusually small trituration grit for the LNV; it is in fact a sort of fine ware.

Fabric 11 Lower Nene valley

Fabric: hard, orange (5YR 6/8) with ochre-brown core. Inclusions: few, including sub-angular quartz, sparse black fragments and rare large (4mm) hard purplish fragment Trituration grit: entirely black slag. Serial No. 20;

Fabric 12 Mancetter-Hartshill potteries, Warks

Fabric: hard cream, sometimes very fine-textured, usually self-coloured. Inclusions: moderately well-sorted, very moderate to sparse, random, translucent pinkish quartz with fewer red-brown fragments. Trituration grits: hard red-brown and/or blackish fragments (upto 5mm); probably re-fired pottery.

Fabric 13 Lincoln

Fabric: cream, smooth, fine-textured and micaceous; self-coloured. Inclusions: sparse to moderate, ill-sorted, sub-angular quartz, and sparse red-brown fragments. Trituration grit: mixed, quartz, flint, brown sandstone (5-6mm) and red-brown ?haematite. Serial nos: 416A; 351; 480A; HS 78 R8/9; 399

Fabric 14 Oxford (Young 1977; Tomber and Dore 1998, 174 (OXF WH)

Fabric: hard, cream, sometimes with a very thick pale orange core or a pale orange 'skin'; self-coloured. Inclusions: moderate tiny quartz, generally well-sorted; sometimes sparse, orange-brown fragments. Trituration grit: translucent quartz, often with pink, brown or grey colouration.

Fabric 15 Oxford colour-coated mortaria (Young 1977; Tomber and Dore 1998, 176 (OXF RS)

Fabric: fine-textured, orange-brown (2.5YR 6/8) with thin drab core; red-brown colour-coat. Inclusions: none visible at x10 magnification. Trituration: as Fabric 14.

Fabric 16 Crambeck late parchment ware (Corder 1937 and 1989; Tomber and Dore 1998, 196)

Fabric; hard, fine-textured, very smooth to the touch; greyish-cream, sometimes with grey or pink core. The surface may be burnished or occasionally have an opaque, red-brown slip. Inclusions: Barely visible at x10magnification, but very occasional, tiny quartz and red-brown fragments evident. Trituration grit: tiny (1-2mm), closely packed black or reddish-brown iron slag.

Fabric 17 Crambeck parchment ware with large trituration grits (Corder 1937 and 1989; Tomber and Dore 1998, 196)

This fabric is identical to Fabric 16 except that it has a coarser (3-4mm), more widely dispersed trituration grit.

Three rim fragments (no.340 with externally grooved base), and 30 body and base sherds; the latter include 5 mortaria with the smooth polished bases, 2 with grooves in the underside of the base (making 3 with no. 340) and 1 other which appears to have an external depression in the base. 7 sherds appear to have had a dark brown or red-brown slip of some kind (see catalogue comments).

Note – The mortaria in the coarser Crambeck fabrics frequently have the remains of a buff-brown slip which has not always been noted.

Fabric 18 Crambeck early whiteware (Corder 1937 and 1989; Tomber and Dore 1998, 196)

Essentially the same as Fabric 17, but the quartz inclusions are readily visible at x10 magnification. Trituration grit as for Fabric 17. Sometimes has a brown-buff slip. This fabric is perhaps more liable than Fabrics 16-17 to have a pink core or occasionally to be pink throughout.

Fabric 19 Crambeck early whiteware

Similar to Fabric 18, but has a perceptibly granular texture, though not so granular as that in the common Verulamium region fabric. Trituration grit as in Fabric 18. Often with buff-brown slip. Sherd no.87 has red- brown stripes painted across the rim.

Fabric 20 Crambeck early whiteware with fine trituration grits

Similar to Fabric 19 but with the tiny (1-2mm), closely packed trituration grit associated with Fabric 16. Sherd no. 286 has a dark brown zig-zag pattern painted, probably all round the rim wall.

Fabric 21 A pottery using forms common to Crambeck (eg nos. 68, 114, 221), and Mancetter-Hartshill (nos. 435, 447), LNV, Swanpool and the Cantley potteries. These forms appear also to have been used by incomers to the Crambeck potteries themselves (see P & H, fig 126 (no. 61 may be in Fabric 22), but those were produced in a fabric readily recognisable as Crambeck.

Greyish-white fabric with a sandwich core of brownish-pink and pale grey, often with a buff-brown slip; very slightly micaceous and can have a slightly soapy texture. The fabric is relatively fine-textured, but at x20 magnification moderate to fairly frequent fairly well-sorted, tiny quartz inclusions are visible with rare red-brown and black material. The trituration grit consists of black iron slag. The sandwich effect is the result of variations from the norm during the firing process, but it is unusual in mortaria made at Crambeck. Fabric 25 exhibits the same features. Often with buff-brown slip, occasionally almost cream.

This author (JE) believes these can fit within the range of fabric 18.

Fabric 22 A workshop probably active in the Catterick/Piercebridge area producing mortaria with Crambeck type rim-profiles
Serial Nos. 28 and 44 are in a slightly granular, orange-brown fabric with buff-brown slip and abundant, tiny, quartz inclusions; no trituration grit survives, but it was fairly certainly black slag. Bodysherd HS 7? 22.8 RF is a finer version of this fabric with polished, buff-brown slip and packed, tiny fragmented black slag trituration grit.

Fabric 23 Catterick/Piercebridge area
Greyish-cream fabric with a thick, well-defined blackish core and drab brown surface; fairly fine-textured and with slightly soapy feel; moderate inclusions of fairly well-sorted quartz with occasional larger (2mm) brown iron fragments. Trituration grit: black iron slag. It can hardly be described as straw-tempered ware, but there is evidence of straw in the clay. Some may have had a cream slip. Serial Nos 47; 345;

Fabric 24 Same source as Fabric 23
Drab buff-brown fabric, sometimes a little orangy, with blue-black core similar to Fabric 23 but thinner; very moderate, ill-sorted inclusions of quartz and brown iron. No trituration grit survives. Some, possibly all, had a cream slip.
Fabric 24 is similar to Fabric 23, but with more inclusions. Serial Nos 5; 92; 149

Fabric 25 Perhaps the same local workshop as Fabric 21
Very slightly micaceous fabric, usually greyish-brown at surface with similar sandwich core to Fabric 21: pale orange-brown with pale grey inner core; sometimes without inner core. Moderate, ill-sorted inclusions, quartz, opaque red-brown, and white fragments. The mortaria may have a cream or a buff-brown slip, perhaps sometimes only on the flange and no. 242, has red-brown stripes as decorative motifs on the hammerhead rim in the manner of Mancetter-Hartshill mortaria. One base body sherd (HS 80 ADK) has red-brown slip on the inside and buff-brown slip on the outside. Trituration grit consists entirely of black iron slag, occasionally purple inside.
In this author's view (JE) closely related to Catterick fabric MB12

Fabric 26 Same local workshop serving Piercebridge as Fabric 24-25 ; looks like a coarser version of 24
Notably softer in texture than fabric 25, but not dissimilar. Slightly soapy to the touch where the surface survives intact. Moderate inclusions: angular, ill-sorted quartz, red-brown, opaque white, and black slag fragments. Trituration grit consists of black slag. Some mortaria have a thin cream slip: Serial nos. 91/177 and 227 may have had a brownish slip.

Fabric 27 Probably to be equated with Catterick MB12, but has links with Fabrics 24-26.
Hard, buff-cream to pale orange-brown fabric, sometimes with very pale brown core. Moderate inclusions of ill-sorted, sub-angular quartz and sparse red-brown fragments (up to 2mm). Trituration grit consists entirely of black iron slag. Thin cream and thick brownish slips were used. There is no example where cream slip was certainly used all

over, but some where the brownish slip was so used (Serial nos.456; 134? The normal practice seems to have been either to have brownish-orange slip on the outside only, or to use the cream slip first and then apply the brown slip on the outside only; sherds Serial nos. 147 and 179 have a horizontal band of brownish slip on the inside at the base of the rim as wells having it on the exterior. All 4 spouts are of the same, thumb depression type.

Fabric 28 = Catterick Fabrics MB12, but has links with Fabrics 24-27
Hard red- to orange-brown fabric, occasionally with dark grey core; moderate inclusions of quartz, sparse red-brown and chalk fragments and occasional feldspar. The texture varies because the inclusions range from being ill-sorted and sub-angular in some mortaria (up to 2mm), to being quite well-sorted (0.5mm) in others. Trituration grit: blackish slag with occasional sandstone fragments. The vast majority of sherds in this group have thin cream slip on the inside and on the rim with orange- to dark red-brown slip on the outside. Sherds Serial nos 319 and 74 have had bands of orange-brown painted inside at the base of the rim. No. 288 is an attempt at a fine ware Drag 45 mortarium. Five spouts survive, all of the finger depression type.
Rim sherds have cream slip on the inside and orange- to red-brown slip on the outside: Serial nos. 27; 42; 43; 59; 74; 76;78; 108; 109/282; 116; 124/284; 111; 153; 163; 176/309; 188; 285; 319; 291; 484; 509; 528; 456
Rim sherds with red slip inside and out: 228 (Dr 45)
Rim sherds with indeterminate slip combinations: Serial nos 2; 24; 29/107+303+281; 80; 290; 172

Fabric 29 This seems to be the equivalent of Catterick Fabrics MB12, but the similarity of the fabric with Piercebridge fabric 33 (except for the trituration grit) raises the possibility of production at Piercebridge.
Hard, fine-textured, orange-brown fabric, occasionally with grey core; fairly frequent inclusions of well-sorted, sub-rounded quartz, sparse red-brown and black fragments with very rare cream clay pellets. Trituration grit: black iron slag.
Two spouts, both thumb depression.
Rim sherds with cream slip on the inside and brown slip on outside: Serial nos 30; 61; 75; 79; 46/211; 145; 312
Body sherds: HS 80 ADA; HS 77 AL, SZ?; BN;
Slips indeterminate: HS 78 XG2;
With cream slip on both sides: Serial nos 213; 243; 249; 327; 337; 338;

Fabric 30 This fabric which was being used for producing Crambeck fine-ware mortarium types (see P & H fig 125, no.42, but with a small flange at the top), was probably produced in the Piercebridge/Catterick area
Hard, fine-textured, orange-brown fabric with drab or grey core; moderate inclusions of small quartz, fairly common white fragments and occasional red-brown material. Trituration grit: fine (2-3mm) black iron slag, packed close together.

With red-brown slip all over and white motifs on rim: 533 and HS 79 SN; 534;
Body sherd: HS 78 ?TB; HS 78 JU; HS 77 ??3B

Fabric 31 Ditto;

A fine-grained, brown fabric, softer in texture than fabric 30 with abundant, minute, quartz inclusions and very rare, tiny slag fragments. The trituration grit probably always consisted entirely of black iron slag. What appears to be identical fabric was used for ordinary mortaria as well as for 'fine ware'. The single example of the former, no. 18 is of the same general type as Corder 110; it had thin, matt, dark brown slip on the outside with cream slip on top of the flange and on the inside with a band of dark brown slip on the inside of the bead; none of the trituration grit survives. A body sherd ((HS 76 11 in circle 4E) and a base/body sherd (HS 77 BJ) are in the same fabric but have a polished red-brown exterior (no slip visible inside, but worn), and have the closely packed, tiny slag trituration grit used in Crambeck, fine ware mortaria.

Fabric 32 The similarity between this Fabric 29 and this fabric and fabrics 33 and 34 (except for the trituration grit) present at the Piercebridge kiln suggests that a later workshop at Piercebridge itself could have been involved in the production of fabrics closely similar to Catterick MB11-12..

Hard, very fine-textured orange- to red-brown fabric, sometimes with very thick, well-defined dark bluish core to about 1mm from the surface; overall, cream slip. Inclusions: very moderate, tiny, but ill-sorted, quartz with rare red-brown and black fragments. Trituration grit: black slag. Fabric represented in this sample by variants of Crambeck mortarium type 6 (Corder 1928, 122) and a Mancetter-Hartshill type Serial no 279 and one possible bodysherd in the style of a Mancetter-Hartshill wallsided mortarium; Serial nos 223+367+183.

Fabric 33 Piercebridge kiln

Hard, orange-brown fabric, with cream slip. The inclusions are moderate to frequent, ill-sorted, but all tiny to smallish, mostly quartz with some red-brown and black material. The randomly distributed trituration grit consists of large chunks of quartz with hackly fracture, up to 4mm across and reaching up to the bead in places. Few are visible because the slip is still intact over much of the surface. 497/267 (27K); HS 80 10.6 AER; HS 81 6.3 AGX

Fabric 34 Piercebridge kiln

Hard, fine-textured, orange-brown fabric with almost black core, sometimes very thick and well-defined and stretching to one mm or less from the surface; cream slip. This is a much finer-textured version of Fabric 33 with fewer, but similar inclusions, which are barely visible. The vessels have been in a reducing atmosphere until late in the firing. Trituration grit as for Fabric 33. 486 (19K); 492 (25K); 489/490 (24K);

Fabric 35 Piercebridge kiln

Self-coloured, orange-brown fabric(2.5YR 5/8) with pale under layer and sometimes a grey core; fine-textured with sparse inclusions: angular quartz, red-brown material, rare black and white fragments and black charcoal remains of plant material in underfired sherds. Much of trituration grit has fallen out, but enough survives to suggest it was as with Fabrics 33 and 34.

Fabric 36 More than one workshop in the Piercebridge/Catterick/Binchester area
Hard orange-brown fabric (2.5YR 6/8), with grey core, sometimes thick (no. 270), usually with cream slip. Moderate, ill-sorted inclusions: angular translucent quartz, sparse red-brown fragments. Trituration grit consists of translucent and opaque quartz, yellow and brown sandstone, red-brown fragments and quartz sandstone (4-5mms). Serial nos 358; 270; HS 81 AKD; HS 77 24.1 AC

Fabric 37 Likely to be in the Piercebridge/Catterick/Binchester area
Very hard, orange-brown fabric (2.5YR 5/8) with cream slip. Moderate inclusions of tiny quartz, but some ill-sorted grains; occasional black and red-brown fragments, very rare soft white calcareous fragments. The trituration grit consists of pale grey vesicular slag like material (unidentified). Serial No 428.
Likely to be Niedermendig lava from a quern (JE).

Fabric 38 Catterick/Binchester/Piercebridge area
Orange-brown fabric (7.5YR 7/8) to (5YR 6/8), moderate to abundant, ill-sorted quartz inclusions, occasional red-brown and rare black fragments. Trituration grit is quartz or may have very rare black fragments. Some have a cream slip, but can probably have a matt self-coloured slip. Serial nos 85; 468; 374; HS 79 16.8 KJ

Fabric 39 Probably Piercebridge
Hard, orange-brown fabric, with cream slip. The inclusions are frequent, moderately well-sorted, tiny to smallish, mostly quartz with occasional red-brown and black material. The trituration grit consists of large chunks of grey material with hackly fracture, and may include quartz and red-brown sandstone. The fabric may be a variant of Fabric 33, but the trituration grit is different. HS 77 24.1 AC;

Fabric 40 Piercebridge/Binchester/Catterick area (worth looking at trituration grit carefully)
Very hard, red-brown fabric (5YR 6/6); with dark grey core and cream slip. Inclusions very moderate, ill-sorted, but mostly tiny to small; random, consisting of quartz, black material and sometimes with calcareous fragments (up to 1.5mm). The trituration grit includes quartz, quartz sandstone, ?haematite, grey and black rock, red-brown sandstone and perhaps slag. Serial nos 403-6 (Anaus; 1 vessel, with calcareous inclusions); 234 (attributable to Anaus); 205; 469 (Mascellio); 537 (Anaus); 401 (attributable to Anaus); 409;

Fabric 41 Piercebridge/Binchester/Catterick area
Hard, orange-brown fabric (5YR 7/8), with medium to light grey core and cream or matt, self-coloured slip. Fairly frequent, mostly tiny to small but some larger inclusions, mostly quartz with few red-brown and black fragments. Serial nos 237; 402 (matt, brown slip); HS 80 8 in circle, 3b

Fabric 42 North-east, probably Piercebridge/Binchester/Catterick area
Very hard, fine-textured, orange-brown fabric (2.5YR 6/8) with dark blue-grey core and probably a matt, self-coloured slip or white slip. Moderate inclusions of tiny translucent and opaque quartz with rare black fragments. The trituration grit consists of mixed quartz, calcareous(?chalk), yellow sandstone, feldspar and black fragments. Serial nos 354; 529.

Fabric 43 north-east, Corbridge a likely source
Brownish-cream to pale brown (10YR 8/4) fabric, may occasionally have pale grey core; self-coloured or self-coloured slip. Fairly frequent inclusions, sub-rounded, mostly tiny to small with some larger; mostly quartz, with rare opaque black and red-brown material. The trituration grit consists of mixed quartz and red-brown sandstone with ?haematite, quartz sandstone and possibly slag. Serial nos 84; PB 73 TF sf307; 186; TF 74 22B

Fabric 44 Piercebridge area most likely source
Pale orange-brown fabric(7.5YR 6/6), slightly micaceous, with grey core and perhaps a cream slip. Abundant inclusions of ill-sorted, angular quartz with occasional red-brown fragments. The trituration grit is mainly translucent quartz and white feldspar (2-3mm) with small black fragments (1mm) and gold mica. HS 78 MH

Fabric 45 Catterick/Piercebridge area
Fine-textured, pale to mid-brown fabric; self-coloured. Inclusions, very moderate very ill-sorted, from minute up to 11mms, quartz, black ?slag, red-brown and perhaps other material. Only one black slag trituration grit survives, but as the potter was following the Crambeck type 6 tradition it is likely that all the grit was black slag. Serial nos 226; 365

Fabric 46
A hard, oxidised fabric with blue-grey core and thin orange-brown margins and surfaces, with occasional moderate sand c0.3mm. Trituration grits; angular white quartz only, c1-3mm

Fabric 48
A hard oxidised fabric with an orange core, margins and surfaces, 'clean', with occasional sand c0.1mm. Surfaces have a thick red-brown slip. Trituration grits; angular white quartz only c1-3mm.

Fabric 49
An oxidised fabric with a grey core, orange margins and surfaces, with some-common sand c0.1mm and occasional ironstone c0.1mm. Trituration grits; angular white grog c1-4mm.

Fabric 50
A hard, oxidised fabric with an orange-brown core, margins and surfaces, 'clean', with occasional brown ironstone c1mm and occasional fine silver mica. Trituration grits; none surviving

Fabric 51

A hard, oxidised fabric with orange core, margins and surfaces, 'clean' and 'soapy' with occasional ironstone up to 2mm. Trituration grits; none surviving.

Fabric 52

An oxidised fabric with a buff-brown core, margins and surfaces with common orange ironstone(?) c0.3-0.5mm and common fairly fine sand c0.2mm. Trituration grits; none surviving.

Fabric 53 Probably Verulamium

A hard fabric with a black core, orange-brown margins and buff, slipped surfaces, with common-abundant moderate sand c0.3mm.

Fabric 54 Probably Piercebridge area

A hard fabric with a pale grey core and buff-brown margins and surfaces, poorly levigated, with some angular quartz and grey stone c0.3-0.5mm and occasional large ironstone c2mm. Also common fine gold mica. Interior brown slipped. Perhaps related to fabric 44. Trituration grits; few survive, some quartz and red and black stone c2mm.

Fabric 55

A hard fabric with a white core and buff-orange margins and buff-brown surfaces, with some fine sand c0.05mm and occasional rounded red ironstone c0.2-0.5mm. Trituration grits; common angular black slag c1-2mm.

Fabric 57

A hard whiteware with a blue-grey core, pink margins and white surfaces, with common angular quartz sand c0.3-0.5mm. Perhaps a Coal Measures clay? Trituration grits; none survive.

Fabric 58

A hard whiteware with a pale grey core and buff-white margins and surfaces, with some sand c0.2-0.3mm and occasional black ironstone c0.2-0.3mm. Trituration grits; none survive.

Mortarium Form catalogue

Fabrics 1-6, Rhenish

Fabric 1, Rhenish

- 1 M1.1 D.147 Serial 411 & 526 A typical Rhenish collared mortarium, AD 150-250, cf Gose (1984), type 451; Gillam (1970) type 272.

Fabric 2, Rhenish

- 2 M1.1 D.103 Serial 193 A typical Rhenish collared mortarium, AD 150-250, cf Gose (1984) type 451; Gillam (1970), type 272.

Fabric 3, Rhenish

- 3 M1.1 D.100 Serial 209 A typical Rhenish collared mortarium with groove on top of rim and very fine trituration grits. AD 150-250, cf Gose (1984) type 451/453; Gillam (1970), type 272.

- 4 M2.1 D.102 Serial 480 A beaded and flanged mortarium, AD 150-250, cf Gose (1984) type 462, 3rd century.

Fabric 5, Rhenish

- 5 M1.1 D.104 Serial 332 A beaded and flanged mortarium with a horizontal, beaded flange, AD150-200, Soller(?), cf Gose (1984) types 461/2

Fabric 6, Probably Soller (Tomber and Dore 1998, 79-80), Rhineland

- 6 M1.1 D.098 Serial 45 A beaded and flanged mortarium with horizontal, thickening flange, AD170-220, Soller.

- 7 M1.2 D.099 Serial 10 A beaded and flanged mortarium with horizontal, beaded flange, AD150-220, Soller.

Fabric 7, Oise, Somme

- 8 M1.1 D.084 Serial 356 Mortarium of Gillam (1970) type 238, AD 70-110.

Fabric 8, Ellingham, Norfolk (Hartley and Gurney 1997)

- 9 M1.1 D.107 Serial 458 A beaded and flanged mortarium with strongly downsloping flange, almost collared. AD180-250

Fabric 9, Probably Brampton, Norfolk

10 M1.1 D.106 Serial 382 A collared mortarium, AD 170-250.

Fabric 10, Lower Nene Valley

11 M1.1 D.108 Serial 383 A beaded and flanged mortarium, perhaps 3rd century.

12 M2.1 D.109 Serial 244 A reeded flanged beaded and flanged mortarium, AD 250-400+

13 M2.2 D.111 Serial 304 A beaded and flanged mortarium with single groove, possibly 3rd century.

14 M2.3 D.115 Serial 60 A beaded and flanged mortarium with horizontal, grooved rim, perhaps cAD350-400.

15 M2.4 D.116 Serial 328 A beaded and flanged mortarium with beaded flange, cf Frere (1984) fig109,2631, AD 350-400.

16 M2.5 D. 141 Serial none A deeply grooved beaded and flanged mortarium with distinctive hooked flange tip, a variant of type M2.1, AD 250-400.

17 M3.1 D.131 Serial 241 An unusual reeded rimmed, near wallsided mortarium. The treatment of the trituration grit also unusual; there is a close unpublished parallel from Ware, Herts, later 3rd-4th century.

Fabric 12, Mancetter-Hartshill, Warwickshire

18 M1.1 D.037 Serial 387 Reeded rimmed hammerhead mortaria, AD 220-350.

19 M1.2 D.029 Serial 360 Reeded hammerhead mortaria, slightly outswept at distal end, AD 220-350.

20 M1.3 D.030 Serial 379 A reeded hammerhead mortaria with slight beads at rim and distal end, cAD 200-260.

21 M1.4 D013 Serial 473 Stubby hammerhead mortarium, probably 3rd century.

22 M1.5 D014 Serial 166 An un-reeded concave hammerhead mortarium, AD 270-370.

23 M1.6 D.033 Serial none Concave reeded hammerhead mortaria, AD250-350.

- 24 M1.7 D.137 Serial none A stepped collared mortarium, perhaps 3rd century.
- 25 M1.8 D.138 Serial none An un-reeded hammerhead mortarium, perhaps 3rd or early 4th century.
- 26 M2.1 D.006 Serial 372 A collared mortarium beaded at rim and distal end, AD 200-220
- 27 M2.2 D.041 Serial 259 A hammerhead mortarium with upright bead and groove at distal end, cAD 200-230.
- 28 M2.3 D.139 Serial none An incipient reeded hammerhead with two grooves, C AD200-250.
- 29 M3.1 D.007 Serial 459 A beaded and flanged mortarium with reeded flange, AD 200-250.
- 30 M3.2 D.009 Serial 503 A 4-reeded hammerhead mortarium with two grooves, AD 200-250.
- 31 M4.1 D.008 Serial 505 A beaded and flanged mortarium with flange rising above bead, flange downsloping, cAD 140-170.
- 32 M4.2 D.145 Serial none A beaded and flanged mortarium with flange rising above bead, hooked at distal end and beaded, cAD 100-140.
- 33 M5.1 D.010 Serial 250 A large thick mortarium beaded with straight, downsloping flange, cAD 170-230.
- 34 M6.1 D.028 Serial 451 Mortaria with bead and straight, downsloping flange, AD 170-200.
- 35 M6.2 D.019 Serial 407 Mortaria with bead and slightly curving, downsloping flange, AD 160-200
- 36 M6.3 D.032 Serial 516 A beaded mortarium with a fairly straight downsloping flange, grooved at the distal end, AD 170-220
- 37 M6.4 D.039 Serial 397 A beaded and flanged mortarium with a strongly defined bead with a bead on the distal end, AD 150-200.
- 38 M6.5 D.025 Serial 422 A beaded, un-reeded hammerhead, AD250-350.
- 39 M6.6 D.144 Serial none A hammerhead mortarium with two grooves, AD 200-350.

- 40 M7.1 D.016 Serial 396 A beaded and flanged mortarium with curving flange, AD160-200
- 41 M7.2 D.017 Serial 430 A beaded and flanged mortarium with strongly downcurving flange, cAD 160-200.
- 42 M7.3 D.142 Serial none A beaded and flanged mortarium, perhaps cAD 140-180.
- 43 M7.4 D.036 Serial 389 A beaded and flanged mortarium, cAD160-220.
- 44 M7.5 D.066 Serial 538 A beaded and flanged mortarium with a broad outcurving flange, inturned at the distal end, AD 140-180.

Fabric 13, Lincoln

- 45 M1.1 D.083 Serial 399 A beaded and flanged mortarium with bead above flange, AD140-180.
- 46 M2.1 D.064 Serial 416A A beaded and flanged mortarium with flange rising above the bead, AD 110-40.

Fabrics 14 and 15, Oxfordshire

- 47 M1.1 D.143 Serial none Oxfordshire (Young 1977) type M17, AD240-300.
- 48 M2.1 Serial 429 Oxfordshire (Young 1977) type M10, AD 180-240. Not illustrated.

Crambeck and Crambeck related fabrics (16, 17, 18, 19, 20, 21 and 22)

- 49 M1.1 Wallsided mortarium, often with slightly curving collar, a variant on the usually common Corder (1937) type 7, Catterick (Wilson 2002a) type M60A. Perhaps mid fourth century.
- 50 M1.2 D.139 A wallsided mortarium grooved at rim and on bottom of collar, a variant on Corder (1937) type7, later 4th century.
- 51 M1.3 Wallsided mortaria grooved below rim, Corder (1937) type 7, c AD 355-400+.
- 52 M2.1 Beaded and flanged mortaria with two grooves on flange near bead, Corder (1937) type 6, cAD 285-355/400.
- 53 M2.2 D.119 Serial 475 A beaded and flanged mortarium, a variant on Corder (1937) type 6 missing grooves on flange, cAD 285-355/400.

- 54 M2.3 D.120 Serial 112 A reeded hammerhead mortarium, cf Corder (1928) no 120, cAD 285-355.
- 55 M2.4 D.123 Serial 165 A reeded hammerhead mortarium with defined bead, cf Corder (1928) no 118, cAD 285-355.
- 56 M2.5 D.124 Serial 124 A beaded and flanged mortarium with incised wavy line on flange, a variant of Corder (1937) type 6, cAD 285-355.
- 57 M2.6 D.125 Serial 119 An unusual beaded and flanged mortarium with a large bead replacing the flange, presumably a variant on Corder (1937) type 6, cAD 285-355.
- 58 M2.7 D.126 Serial 435 An unreeded hammerhead mortarium, perhaps cf Catterick type M46A. Later 3rd-mid 4th century.
- 59 M2.8 D.127 Serial 231 A hammerhead mortarium with a three-cordoned rim, perhaps cAD 285-355.
- 60 M3.1 A parrot's beak mortarium, a variant of Corder (1937) type 8 with a heavy, sometimes hooked upper bead, cAD355-400+.
- 61 M3.2 A parrot's beak mortarium, Corder (1937) type 8, cAD355-400+.
- 62 M3.3 A parrot's beak mortarium, a variant of Corder (1937) type 8 with insloping flange, cAD355-400+.
- 63 M4.1 A collared mortarium(?) with beaded rim and flange, perhaps mid 4th century.

Fabric 18A, Crambeck related

- 64 M1.1 D.132 Serial 197 A wallsided mortarium with groove on the lower wall, with red paint band along it. Perhaps a variant of Crambeck (Corder 1937) type 7. Probably 4th century.

Fabric 30, Crambeck related

- 65 M1.1 A distinctive variant on Crambeck type 8 in an oxidised fabric with white painted decoration, a wallsided form with two large cordons at top and bottom of collar. Probably mid-late 4th century.
- 66 M2.1 A red slipped Dr 45 copy mortarium, probably 4th century.

Fabric 31, possibly Crambeck related

67 M1.1 D.130 Serial 18 An oxidised mortarium beaded with a large cordon on the flange, perhaps cf Corder (1928) No 110, perhaps 4th century.

Fabric 45, possibly Crambeck related

68 M1.1 D.060 Serial 226 A mortarium with a bead and straight, reeded flange, cf Corder (1928) no 110, perhaps 4th century. Fabric clean and closer to fabric 50.

69 M1.2 D.061 Serial 365 An mortarium beaded with a cordon on the flange, perhaps cf Corder (1928) No 110, perhaps 4th century.

Fabric 55, possibly Crambeck or Cantley tradition related

70 M1.1 D.154 Serial none A beaded and flanged mortarium with horizontal flange, beaded at the distal end, perhaps 4th century.

Fabrics in the Catterick Cantley tradition (fabrics 23-29)

71 M1.1 D.049 Serial 225 A reeded hammerhead mortarium, cAD 250-350.

72 M1.2 D.044 Serial 146 An unreeded hammerhead mortarium, cAD 250-350. (not illustrated).

73 M1.3 A concave, unreeded hammerhead mortarium, Catterick (Wilson 2002) type M46, cAD 250-350.

74 M1.4 A collared mortarium with near vertical flange with two ridged cordons, cAD 250-350.

75 M1.5 D.051 Serial 213 A reeded hammerhead type mortarium with defined upper bead, (cf Crambeck and related type M2.4 above), cAD 250-350.

76 M1.6 D.054 Serial 111 A three cordoned hammerhead with fairly horizontal flange, cAD 250-350.

77 M1.7 D.055 Serial 172 A collared mortarium with grooves at top and bottom of collar, cAD250-350.

78 M1.8 D.056 Serial 29 A triple-beaded flanged mortarium with bead at top and bottom, cf M1.7, this type of much more triangular section, cAD250-350.

79 M1.9 D.057 Serial 223 A hammerhead mortarium with rim divided into three cordons, lower one vertical, cAD300-350. Not illustrated. See M32, M1.2 for illustration of the form.

80 M1.10 D058 Serial 345 A curving collared mortarium rim divided into three cordons, cAD250-350.

- 81 M1.11 D.146 Serial none A small concave hammerhead mortarium, a miniature version of Catterick (Wilson 2002) type M46A perhaps, cAD250-350.
- 82 M2.1 D.052 Serial 211 & 46 A beaded and flanged mortarium with straight flange, cAD250-350.
- 83 M2.2 D.053 Serial 249 A beaded and flanged mortarium with high bead, fairly horizontal tapering flange with groove on end, perhaps cAD300-350.
- 84 M2.3 D.134 Serial 199 A beaded and flanged mortarium, reeded on the flange (cf Crambeck and related mortaria M2.4), probably cAD300-350.
- 85 M2.4 D.149 Serial none A beaded and flanged mortarium with stubby, swelling bead, possibly cf Oxford (Young 1977) type M22, cAD250-350.
- 86 M3.1 D.135 Serial 319 An unreeded hammerhead mortarium, generally similar to Catterick (Wilson 2002a, Fig 185, M43), on drawn example brown slip outside; cream inside, band of brown slip on inside of bead; cf M1.2 above, cAD250-350.

Fabric 32, possibly Cantley tradition

- 87 M1.1 D.133 Serial 279 A plain wallsided mortarium with red painted decoration reminiscent of that found on Mancetter and Catterick Cantley tradition vessels. Probably 4th century.
- 88 M1.2 D.057 Serial 223 A hammerhead mortarium with rim divided into three cordons, lower one vertical, probably 4th century.

Early oxidised fabrics

Fabrics 33-35, Piercebridge kiln (see Hartley Kiln Products below p000)

- 89 M1.1 D.096 Serial 496 A beaded and flanged mortarium with broad, curving, shallow flange rising above bead, AD 90-120.
- 90 M1.1 D.096 Serial 499 A beaded and flanged mortarium with broad, curving, fairly horizontal flange rising above bead, AD 90-120.

Fabric 36, early oxidised

- 91 M1.1 D.079 Serial 358 A beaded and flanged mortarium with broad, curving, fairly horizontal flange level with bead, AD 90-120.
- 92 M2.1 D.080 Serial 270 Mortarium of Bushe-Fox type 26-30, form as Saturninus based at Catterick, (Wilson 2002a, fig.168, MS38), AD 100-140.

Fabric 37, early oxidised

- 93 M1.1 D.078 Serial 428 A beaded and flanged mortarium, bead slightly above broad, horizontal flange, 2nd century. The vessel is probably a one-off, the trituration grits appear to be Niedermendig lava recycled from an old quernstone.

Fabric 38, early oxidised

- 94 M1.1 D.071 Serial 374 A beaded and flanged mortarium with broad, curving, fairly horizontal flange rising above bead, form as Catterick (Wilson 2002a, fig 184, M16), AD 100-140. Mortarium stamp MS11 (see Hartley below p. 9-132), Saturninus.
- 95 M2.1 D.075 Serial 85 Mortarium of Bushe-Fox type 26-30, form as Saturninus based at Catterick, (Wilson 2002,fig.168, MS38), AD 100-140.
- 96 M3.1 D.076 Serial 408 A beaded and flanged mortarium with bead rising above broad horizontal flange sharply down-turned at end and grooved at distal end, AD100-150.

Fabric 40, early oxidised

- 97 M1.1 D.081 Serial 401 A beaded and flanged mortarium with broad flange rising above bead and sharply down-curved with groove on tip of distal end, the latter is a feature of the Catterick/Corbridge potter Anaus, AD120-140.

Fabric 41, early oxidised

- 98 M1.1 D.073 Serial 402 A beaded and flanged mortarium with broad flange rising above bead and out-curving at end, AD120-140, See Hartley (below p. 9-131), Stamp MS8, Anaus.

Fabric 42, early oxidised

- 99 M1.1 D.077 Serial 354/529 A mortarium of Gillam (1970) type 237, a military product with concentric scoring inside and on flange, AD 60-90.

Fabric 50, early oxidised

- 100 M1.1 D.150 Serial none A beaded and flanged mortarium with strongly curving flange rising above bead, form similar to early Mancetter vessels, cf Catterick (Wilson 2002a) type M71, AD 130-80, perhaps AD 130-70.

Fabric 51, early oxidised

- 101 M1.1 D.152 Serial none Flange fragment of large mortarium with straight, downsloping flange, perhaps later 1st-2nd century.

Early Verulamian

Fabric 53

102 M1.1 D.153 Serial none A beaded and flanged mortarium, with deep down curving flange. Probably Verulamium region, AD 60-90.

Other whitewares

Fabric 58

103 M1.1 D.156 Serial none A collared mortarium with insloping collar, reeded, perhaps later 2nd-early 3rd century.

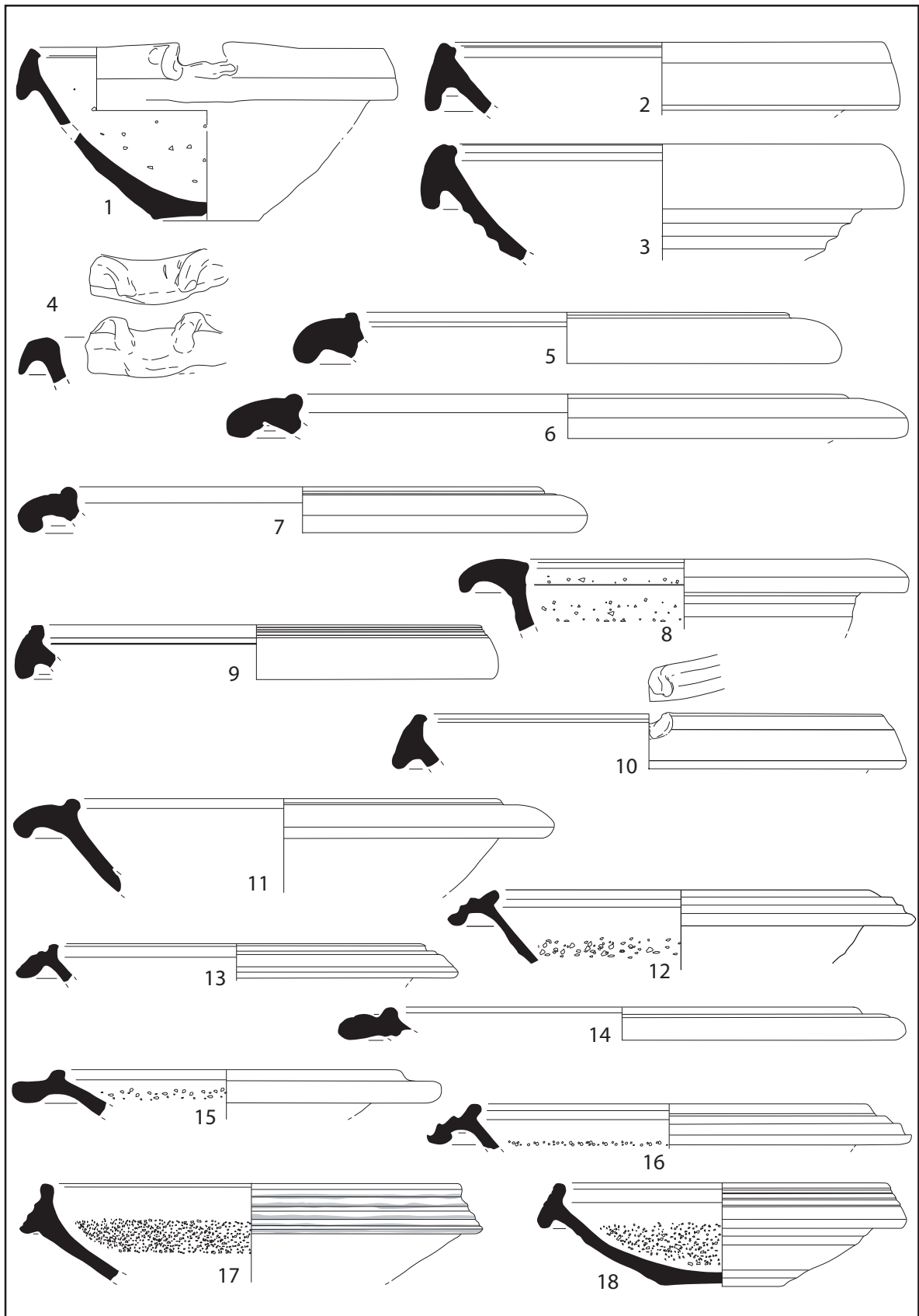

Fig. D9.21 Mortaria forms 1-18

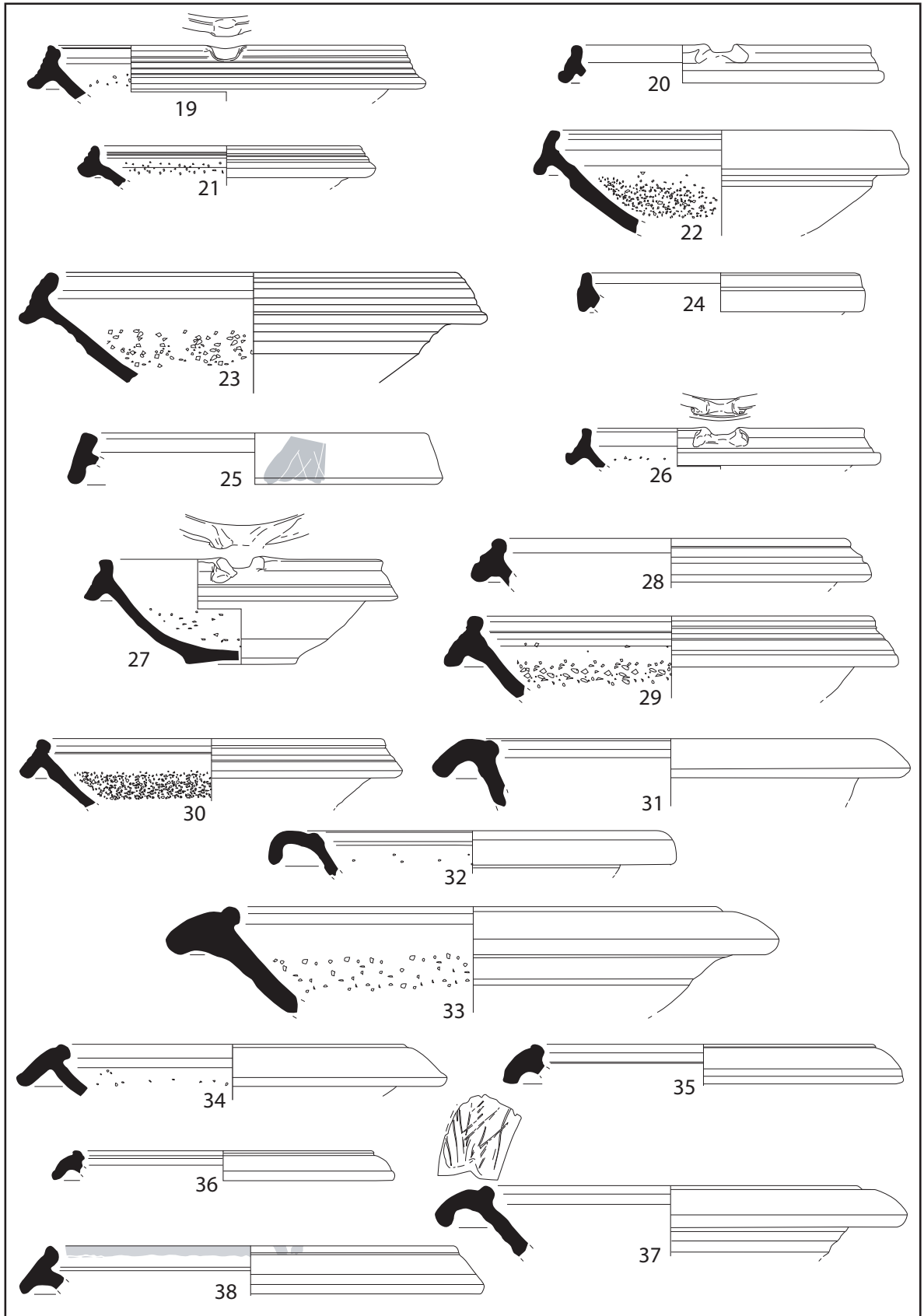

Fig. D9.22 Mortaria forms 19-38

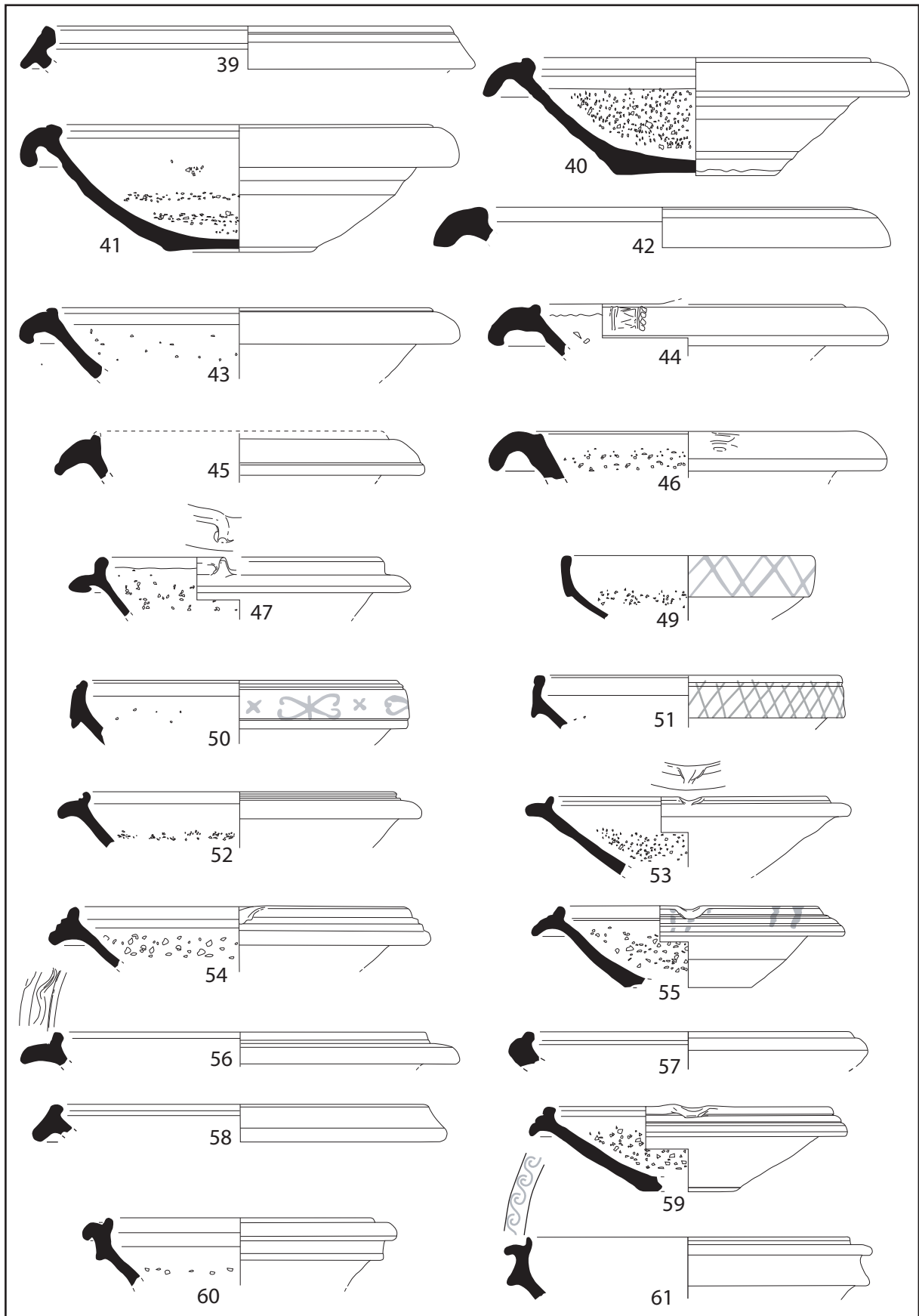

Fig. D9.23 Mortaria forms 39-61

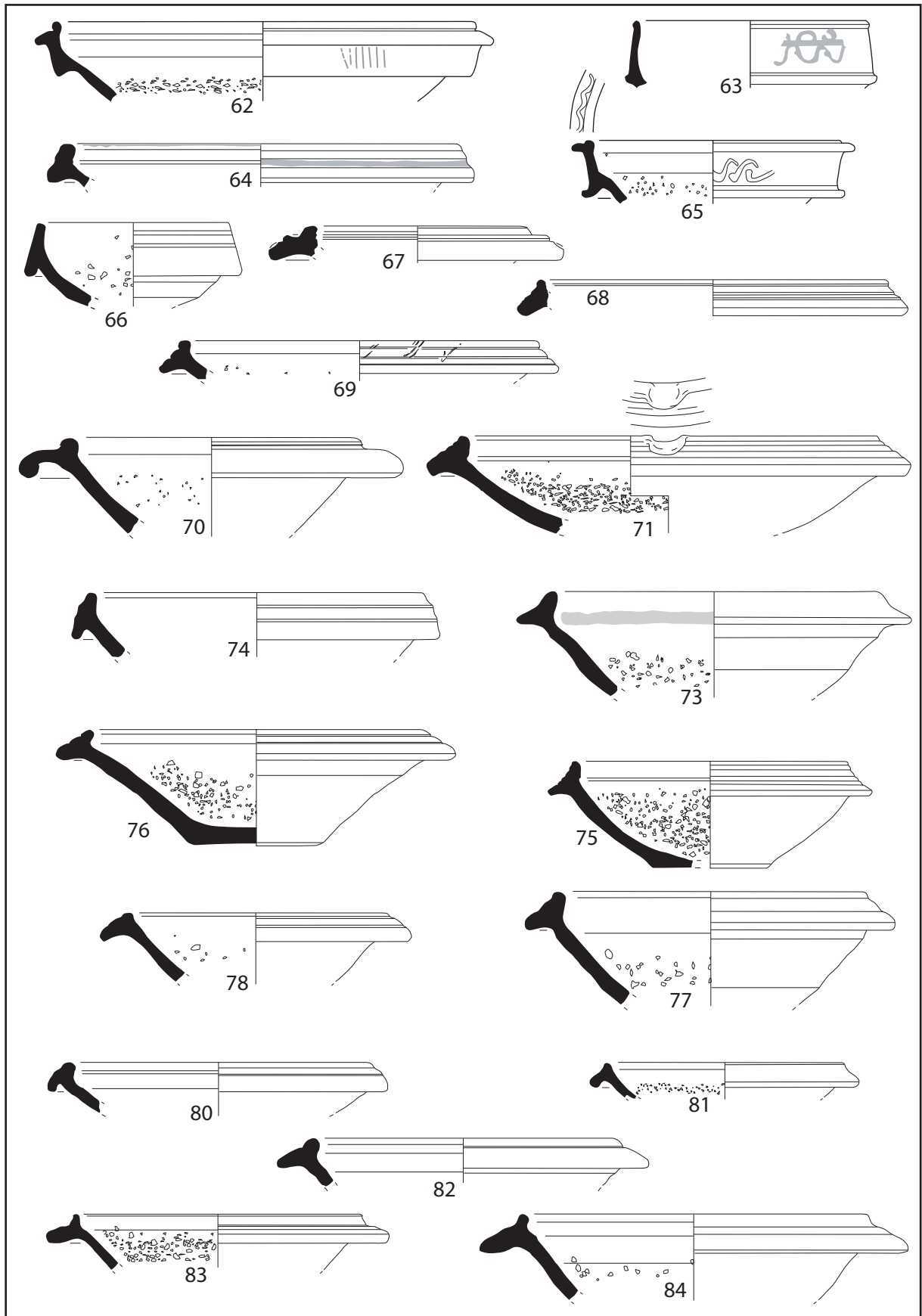

Fig. D9.24 Mortaria forms 62-84

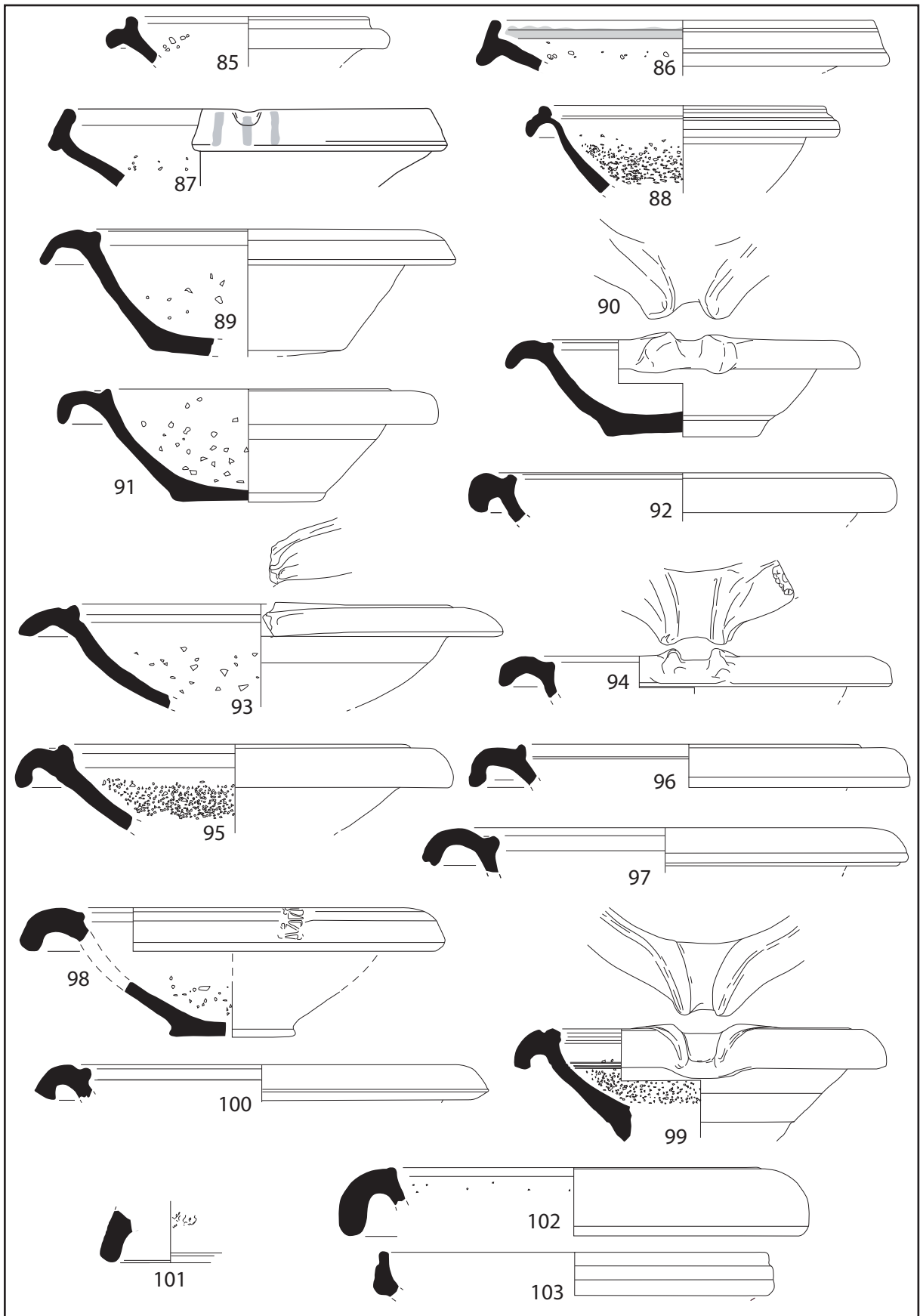

Fig. D9.25 Mortaria forms 85-103