

Source No: SHE 18517
Event No: EHE 1851



Herefordshire Archaeology
Planning Services
Sustainable Communities Directorate
Herefordshire Council

Further Investigation of the Rotherwas Ribbon Stage 2: 2010 Excavation Assessment/Interim Report

NGR: 35050 23660

**Herefordshire Archaeology Report No 281
(In Execution of EH Project Design 5463)**

Report prepared by
I. Bapty & D. N. Williams

With contributions from
M. Allen, I. Baxter, N. Daffern, E. Edwards, C J. Evans, L. Pearson, A. Richards, H.
Lamdyn-Whymark

Herefordshire Archaeology
PO Box 230, Blueschool House,
Blueschool Street, Hereford HR1 2ZB

Herefordshire Archaeology is Herefordshire Council's county archaeology service. It advises upon the conservation of archaeological and historic landscapes, maintains the county Sites and Monuments Record, and carries out conservation and investigative field projects. The County Archaeologist is Dr. Keith Ray.

1. Introduction

The report presents an assessment of the preliminary results of a Herefordshire Archaeology led excavation to further investigate the remains of the unusual Neolithic/Bronze age structure known as the 'Rotherwas Ribbon'.

The project was commissioned by English Heritage in February 2010, and with the kind permission of the landowner the excavation took place in February and March 2010. The Assessment/Interim report was completed in March 2011.

2. The Rotherwas Ribbon

The Rotherwas Ribbon is an unusual and enigmatic Neolithic or Early Bronze Age linear structure consisting of a 6 to 8 metre wide stone surface located within a linear hollow. A 67 metre length of the Ribbon was identified, uncovered and partly excavated in 2007 during a PPG16 supported archaeological recording exercise in advance of the construction of the Rotherwas Access Road, Herefordshire. The structure was associated with a significant bone, pottery and flint artefact assemblage, and also appeared to be spatially and chronologically linked with a group of eight pits (six of which were filled with burnt stone) which were located immediately adjacent to the Ribbon. Radiocarbon dates suggest a late 3rd/early 2nd millennium BC date range for the feature.

The precise understanding of the Ribbon remains uncertain. On the one hand, the Ribbon appears to represent a 'new' category of Early Bronze Age (and perhaps later Neolithic?) monument of uncertain purpose, but with potentially significant implications for the understanding of local, regional and national archaeological sequences from this period. On the other hand, the apparently unusual nature of the structure demands that it is more fully understood before its wider significance can be evaluated. In particular, key questions concerning the relative interplay of natural and cultural processes in the creation of the Ribbon remain to be fully answered, and its full extent is also unknown

Additional EH funded Geophysics and Lidar survey was undertaken under the management of Herefordshire Archaeology in late 2009. The geophysics survey results positively indicated the likely presence of a linear feature extending north and south from the known Ribbon section.

3. The Further Excavation Project

The project involved excavation of five 30 X 3 metre evaluation trenches along the possible extension of the Rotherwas Ribbon. The investigation process included appropriate programmes of geoarchaeological and palaeoenvironmental sampling and analysis, and an OSL (Optically Stimulated Luminescent dating) sampling programme. The work was carried out in close collaboration with an EH advisory team, and involved a joint excavation team from Herefordshire Archaeology and the Worcestershire Historic Environment and Archaeology Service (WHEAS).

The results across the five trenches revealed multi-period archaeological deposits dating from at least the Mesolithic to the Roman periods. One probable further section of the Rotherwas Ribbon was certainly identified (Trench 3 to the north of the Access Road), and this has tended to confirm the likely date and cultural context of the Ribbon. Elsewhere a complex series of deposits were found where hollows/channels were associated with stone surfaces of varying dates. In Trench 5 (adjacent to the Rotherwas Futures site) a probable Bronze Age burnt mound sealed

earlier pits and surfaces. By contrast, the features in Trenches 1 and 2 (south of the Road) were mainly of Roman date, and suggest the presence of a Roman settlement in this locality. Meanwhile, in Trench 4, an ancient water channel (probably active in the Neolithic/Bronze Age period) has emphasised the role of alluvial processes in this part of the earlier prehistoric Rotherwas landscape.

4. Conclusions

The preliminary artefact, geoarchaeological and environmental specialist studies have amplified contextual understanding of the Ribbon and its environs, although clear interpretation of the 'Rotherwas Ribbon' remains elusive at this interim stage, and questions concerning its extent, nature and purpose remain to be fully answered.

The Assessment Report sets out a programme of post excavation work which will attempt to further address the project aims via the significantly enhanced information now available. That process will include additional geoarchaeological and palaeoenvironmental analytical work, scientific dating, and completion of the other specialist and excavation reportage to final report standard.

Contents

Section 1: Background	1
1.1 Introduction	1
1.2 The Rotherwas Ribbon: 2007 Excavation	1
1.3 Proposed Further Investigation Programme	2
1.4 Stage 1 Results	2
Section 2: Further Excavation Project	3
2.1 Introduction	3
2.2 Project Location	3
2.3 Site Geology	4
2.4 Project Aims and Objectives	4
2.5 Project Methodology	5
2.6 Personnel and Management	6
2.7 Timescale and Field Conditions	6
Section 3: Further Excavation Project Results	8
3.1 Trench 1	8
3.2 Trench 2	12
3.3 Trench 3	16
3.4 Trench 4	23
3.5 Trench 5	30
3.6 Preliminary Discussion and Findings	39
Section 4: Specialist Reports	47
4.1 Prehistoric Pottery	47
4.2 Roman Pottery	48
4.3 Struck Lithics	51

4.4 Animal Bone	56
4.5 Environmental Remains	59
4.6 Geoarchaeology	68
Section 5: Discussion and Recommendations	93
5.1 Towards a Combined Interpretation	93
5.2 Proposed Post Excavation Work	99
Section 6: References	109
Section 7: Appendices	112
Appendix 1: Stratigraphic Matrices and Finds Catalogue	112
Appendix 2: Geophysics Results Reassessment	128
Appendix 3: Geoarchaeology - Profile Descriptions	130
Appendix 4: Geoarchaeology - Clast Records	134
Appendix 5: Lithological and Shape Characteristics	138
Appendix 6: The Flint Assemblage By Trench	150
Appendix 7: Environmental Tables	151

1. BACKGROUND

1.1 Introduction

This document provides an Assessment Report (in line with MORPHE procedure) for an archaeological excavation undertaken at Rotherwas, Herefordshire in February and March 2010.

The project was managed by Herefordshire Archaeology as Stage 2 of a programme of further work to evaluate the 'Rotherwas Ribbon' (first discovered in 2007), and was funded by English Heritage (HEEP) via EH Project Design 5463.

1.2 The Rotherwas Ribbon: 2007 Excavation and Findings

The Rotherwas Ribbon is an unusual and enigmatic Neolithic or Early Bronze Age linear structure consisting of a 6 to 8 metre wide burnt stone surface located within a hollow/cut. A 67m length of the Ribbon was identified, uncovered and partly excavated in 2007 during a PPG16 supported archaeological recording exercise in advance of the construction of the Rotherwas Access Road, Herefordshire. The structure was associated with a significant bone, pottery and flint artefact assemblage, and also appeared to be spatially and chronologically linked with a group of eight pits (six of which were filled with burnt stone) which were located immediately adjacent to the Ribbon. The Ribbon was also cut by two later (Iron Age/Roman?) ditches on broadly the same alignment, and itself cut an earlier linear feature. A group of six radiocarbon dates (obtained from carbonised hazel samples from two of the pits and a charcoal spread on the Ribbon surface) lie within a late 3rd/early 2nd millennium BC date range, and suggest that the last use of the feature was during this period.

The initial post excavation work and analysis has been reported within an Assessment Report and Updated Project Design including a detailed structural description and assessment of the excavated section of the Ribbon (Sworn *et al* 2009). The 2007 post excavation process has raised a series of key questions about the nature and status of the Rotherwas Ribbon. On the one hand, the Ribbon appears to represent a 'new' category of Early Bronze Age (and perhaps later Neolithic?) monument of uncertain purpose, but with potentially significant implications for the understanding of local, regional and national archaeological sequences from this period. On the other hand, the apparently unusual nature of the structure demands that it is more fully understood before its wider significance can be evaluated. In particular, key questions concerning the site formation process (relative interplay of natural and cultural processes in the creation of the Ribbon?), the extent of the Ribbon beyond the Access Road corridor, the detailed structural composition of the monument, and its date across the full period of cultural activity associated with the structure, cannot be answered simply from the data provided by the 2007 excavation work (see Sworn *et al* 2009, and EH Project Design 5463 for detailed elaboration of these research questions).

1. 3 Proposed Further Investigation Programme

In consultation with English Heritage and the Rotherwas Prehistory Advisory Panel, a two stage further research process was devised to address the questions arising from the 2007 excavation.

At Stage 1 remote sensing techniques (Lidar and geophysics) would permit initial assessment of the potential presence, survival and nature of comparable deposits in the fields either side of the known Ribbon section.

Subject to the results of Stage 1, Stage 2 would potentially involve further targeted excavation to 'ground truth' the Stage 1 results, and to address the key research questions arising from the 2007 investigation.

1. 4 Stage 1 Results

With funding support from English Heritage (under Project Design 5463 Stage 1) and the kind agreement of the landowner, Stage 1 was carried out in late 2009 under the management of Herefordshire Archaeology (Lidar data/analysis supplied by the Environment Agency, Geophysics survey/analysis undertaken by Contract Archaeology). The Lidar results were, unfortunately, inconclusive with respect to the identification of any significant trace of a more extensive 'Ribbon' hollow (Bapty and Atkinson 2011).

However, the geophysics survey results did indicate the possible presence of a linear feature extending north and south from the known Ribbon section (Boucher 2010, see Appendix 2 for overview plan). Analysis of the combined geophysics data suggested that the identified feature was likely to be of archaeological interest, was located on the margin of the principal zones where down-slope water action is naturally focused, and was potentially associated with areas of burning and other contextual variation.

2. FURTHER EXCAVATION PROJECT

2.1 Introduction

In the light of the Stage 1 results, the Project Design for the ‘Stage 2: Further Excavation’ project was developed by Herefordshire Archaeology in early 2010. HEPP funding was provisionally agreed in February (subject to some additional editing of the Project Design), and work commenced in mid February.

It should be noted that the project timescale was partly necessitated by a pending change in March 2010 from arable to orchard land-use in the southern part of the proposed excavation area. We are grateful both to English Heritage for facilitating the project within this window, and to the landowner for permitting access in advance of the orchard planting.

2.2 Project Location

The excavation work was undertaken in the fields to the north and south of the 2007 Ribbon excavation, now buried beneath the Rotherwas Access Road (which links the A49 near the Grafton Inn to the B4399 on the east side of Hereford).

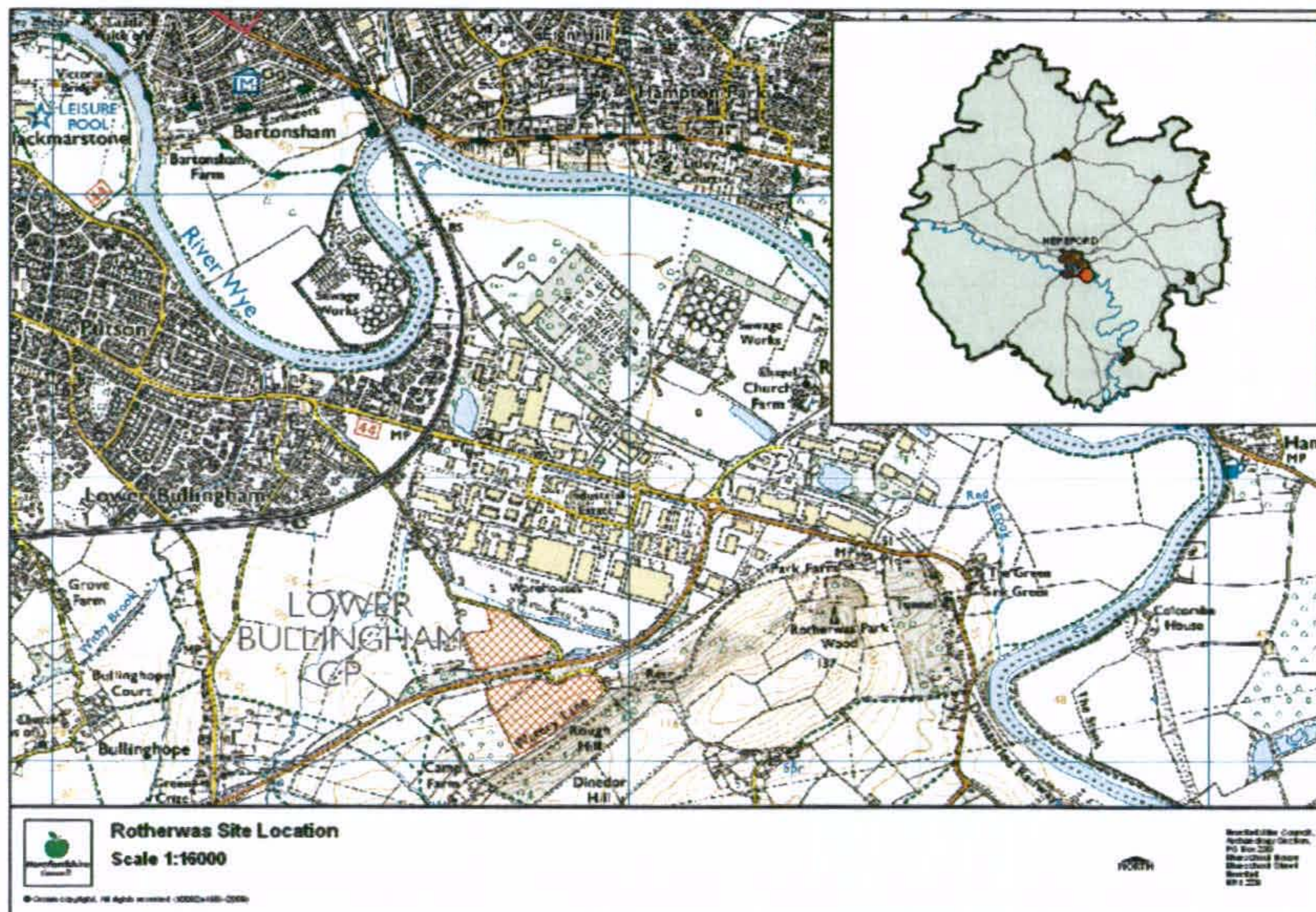

Figure 1: Site Location (centre point: NGR 35050 23660)

2.3 Site Geology

The underlying bedrock is Devonian Lower Old Red Sandstone of the Raglan Mudstone Formation. Much of the drift geology is made up of river terrace deposits.

The soils are of the Newnham Series that consists of reddish coarse and fine loamy soils over gravel while in the valley base. Locally some areas are effected by groundwater.

2.4 Project Aims and Objectives

Aims

- To ‘ground truth’ the Stage 1 remote sensing data results, and to positively demonstrate the existence, location and extent of the Rotherwas Ribbon beyond the road corridor;
- To further assess the nature of the Rotherwas Ribbon, and the relative interplay of cultural and natural processes in the formation of the observed feature;
- To develop better understanding of the landscape/local landform context of the Rotherwas Ribbon;
- To refine the dating of the Rotherwas Ribbon;
- To build improved interpretation of the cultural associations and use of the Rotherwas Ribbon;
- To inform the development of a conservation and management strategy for the Ribbon, and to underpin that strategy by providing absolute information about existence, extent and archaeological significance of the monument.

Objectives

- To assess the characteristics of the Rotherwas Ribbon beyond the road corridor, and the consistency of those characteristics along the complete monument;
- To further test the combined relationship, character and formation process of the Ribbon surfaces, intervening silt/other deposit horizons, and the Ribbon ‘construction cut’ (in so far as these components are collectively present along the monument as a whole);
- To further assess the exact origins and nature of the ‘construction cut’ (in so far as this feature is present in the evaluation areas);
- To assess the relationship of the Rotherwas Ribbon to other archaeological features in its vicinity including associated pits, the known earlier ditch, and the known later ditches, and to interrogate the reasons for the coincidence of these features in one corridor (in so far as such coincidence is observed);

- To further assess patterns of artefact deposition associated with the Ribbon, and to evaluate the precise site formation processes which created those patterns;
- To identify additional dating evidence for the construction/development phases of the Ribbon, particularly with respect the recovery of dating material (C14, OSL: and artefact) sealed by the Ribbon surfaces;
- To undertake a detailed clast description and analysis of the Ribbon surface, and to assess the likelihood of natural or cultural origin through this process;
- To undertake a lithological description of the Ribbon stones, and to establish the probable source of the parent material;
- To undertake detailed sampling of the soil/silt/colluvial/fill deposit sequences associated with the burial, context and creation of the Rotherwas Ribbon;
- To undertake palaeoenvironmental sampling of secure/sealed archaeological contexts associated with the Ribbon, including potential recovery of pollen, plant macro-fossil and charred plant remains;
- To provide evidence support, if appropriate, the development of a Conservation Management Plan for the Rotherwas Ribbon as part of the wider Rotherwas historic landscape;
- To provide information which will inform the development of the Herefordshire Local Development Framework, and to create a context for positive awareness of the Ribbon in the Herefordshire forward planning context;
- To provide a basis for the production of further public information about the Rotherwas Ribbon.

2.5 Project Methodology

The detailed project methodology is set out in the Project Design (Bapty 2010).

In summary, the project involved excavation of five 25 x 3 metre evaluation trenches located with respect to the geophysics results along the suggested extension of the Rotherwas Ribbon (Fig 2). Under archaeological supervision, all trenches were initially excavated by machine down to natural or archaeological deposits. The remaining deposits were then excavated by hand.

The stratigraphic sequences exposed in all trenches during the excavation were recorded by running context and scale drawings (1:20 for plans and 1:10 for sections). Context sheets were completed for all identified contexts. Photographic records were also made on digital media during the excavation.

Detailed provision was made for excavation of deposits identified as ‘the Ribbon’ to include full sectioning and recording of the Ribbon and associated features (including the ribbon hollow, and the deposits under the Ribbon) in all trenches where the Ribbon was identified.

The investigation process additionally included agreed programmes of geoarchaeological and palaeoenvironmental sampling and analysis, and a dating programme including Optically Stimulated Luminescence dating (OSL) and Radiocarbon dating (C14). Sampling of various materials on-site, were undertaken either by the allotted specialist or by site staff after consultation with the allotted specialist. All bulk samples taken were recorded on plan. Column and OSL locations were recorded on section drawings.

Backfilling was carried out by machine.

2.6 Personnel and Management

The excavation was managed/directed by Herefordshire Archaeology (Peter Dorling), and undertaken by a combined professional team consisting of site staff from Herefordshire Archaeology and Worcestershire Historic Environment and Archaeology Service (WHEAS).

Trench supervisors were as follows:

Trench 1 – D. N. Williams (HA)

Trench 2 – T. Hoverd (HA)

Trench 3 – S. Sworn (WHEAS)

Trench 4 – A. Mann (WHEAS)

Trench 5 – D. N. Williams (HA)

It should additionally be noted that the fieldwork was directly informed by liaison with relevant English Heritage specialist staff, who, as well as inputting to the development of the Project Design, also undertook advisory site visits in the course of the work.

Further advisory support was provided by members of the Rotherwas Prehistory Advisory Panel (established in 2008 under the chairmanship of Tony Fleming, English Heritage Inspector of Ancient Monuments)

2.7 Timescale and Field Conditions

The excavation was undertaken in two parts. The first, consisting of the excavation of Trenches 1 and 2, south of the Rotherwas Access Road, took place between 2nd February and the 10th February. During this period the weather was far from ideal with heavy snow and generally wet conditions.

The second period of work, the excavation of Trenches 3 to 5, north of the Rotherwas Access Road, was excavated between 15th February and 17th March. During this period work was stopped due to heavy snowfall and was generally very cold.

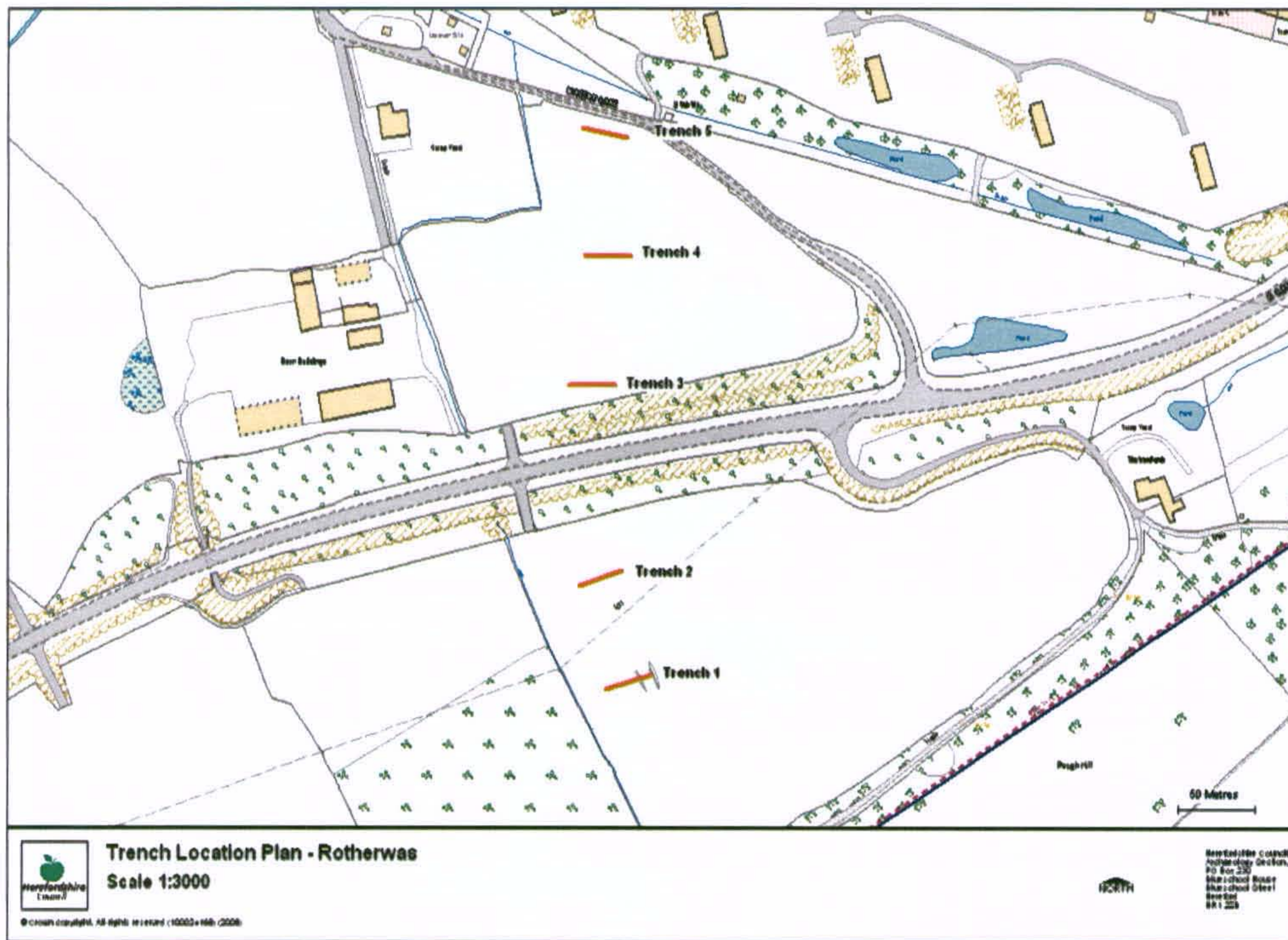

Figure 2: Trench Locations

3. FURTHER EXCAVATION PROJECT RESULTS

3.1 Trench 1 (28m x 3m, see Appendix 1, Figure 2)

Trench 1 was the most southerly of the trenches and the furthest upslope. The trench was extended by 3m during the initial opening by machine to clarify deposits uncovered at the east end. Although this extension was technically outside the original brief, full understanding of these eastern deposits was deemed to be of potential relevance to the overall project aims and objectives.

The topsoil (2500) consisted of a dark brown friable clay silt with occasional small fragments of sandstone, that had an average depth of 0.35m. Underlying this was a 0.10m deep band of red-brown clay silt (2501), again with occasional small fragments of sandstone. For a further depth of 0.04m, the matrix remained the same but the stone content increased considerably (2506).



Plate 1: *Both upper (2511) and lower (2517) surfaces with the concentration of larger stones down the middle (beyond the ranging rod [© Herefordshire Archaeology]).*

The next two layers related to a substantial stone surface which apparently crossed the trench on a broadly north-south alignment, and which was c.6m wide and c.0.16m deep. The 0.08m deep upper surface horizon (context 2510) is probably the result of plough action into the top of the surface. It consisted of a mixed stone/clay/silt dark red-brown matrix (similar to, but darker than 2506), with a significant increase in the size and quantity of stone towards the base of the layer where an almost continuous deposit was



Plate 2: *The lower surface (2517) and its associated ditch as viewed from the south. The cut into the natural is just visible along the left hand side (© Herefordshire Archaeology)*

A shallow ditch (2512) marked the eastern side of surface 2510/2511. This ditch was 0.30m wide x 0.08m deep, was cut into the natural, and was visible across the entire width of the excavation area.. Fragments of Roman pottery were recovered from the fill of the ditch. The western side of surface 2511 occupied a cut into the natural.

Underlying the stone surface (2511) was a very thin band (0.02m) of dark red-brown silt (2515). Beneath this was a second, north-south aligned stone surface (2517). This was 1.40m wide x 0.14m deep, and formed a complete surface consisting of both rounded and angular stone ranging in size from 0.02m diameter to 0.10m. As with 2510/2511, this surface also contained small sandstone fragments. The lower part of the surface comprised a 0.18m deep horizon which, although still containing abundant stone, showed an increasing proportion of silt within the matrix. Roman pottery was recovered from this basal silty horizon. The surface overlay the natural, and occupied a cut into the natural.



Plate 3: *Large stone (2503) band within the dark brown cut fill (2518), located at east end of trench 1 (© Herefordshire Archaeology).*

The east end of the trench was extended during the machine cut to identify features that became visible after the removal of both the topsoil (2500) and the subsoil (2501 [Plate 3]). Underlying the subsoil was a clearly defined band of dark soil (2518) within a c.3m wide cut (2530) and down the centre of this feature was a band of large stone (2503) initially identified by the machine bucket (Plate 3). This stone band (2503) was aligned north-south, was visible across the width of the trench and was c.1.50m wide. The stone in this band was predominantly angular and averaged in size c.0.70m x 0.40m x 0.10m.

Underlying both 2503 and 2518 was a compact stone surface (2532 [Plates 4 and 5]), which lies directly on the natural at the base of cut 2530. This surface was aligned roughly northwest-southeast. A 1.80m length was exposed and was shown to be 1.70m wide and 0.08m thick. The stones of this surface varied in size from 0.05m to 0.18m diameter, and, in contrast to other two surfaces identified within Trench 1, included fire cracked stone, fragments of sandstone and quartz pebbles. Finds from the surface matrix consisted of 14 pieces of bone.

As with the two surfaces in the central area, the east side of 2532 was marked by a ditch cut into the natural clay. The ditch (2526) was parallel to the surface; it was 1m wide and 0.32m deep and contained two fills. The upper fill (2525) was 0.20m deep and consisted

of a mid-brown silty clay with occasional small rounded and angular stones with occasional fragments of charcoal and bone. The lower horizon consisted of a sandy silt, but no finds were recovered (Plate 5).



Plate 4: *Compacted stone surface (2532) laid onto the natural (© Herefordshire Archaeology).*



Plate 5: *Same surface (2532) showing its associated ditch (2526 [© Herefordshire Archaeology]).*

Three other narrow ditches were recorded within the trench (2504, 2505 and 2509), and all contained pottery of Roman date.

Preliminary Assessment

- Most of the features/contexts are associated with or underlain by Roman pottery and are therefore of Roman or later date;
- The presence of apparent building debris (context 2503) implies the presence of substantial buildings/a Roman period settlement in the immediate vicinity.

In terms of the project aims:

- The trench has established that the Stage 1 geophysics results in this area correctly indicated the presence of cultural deposits. However, no cultural or natural deposits were found which explained or coincided with the additional zone of higher conductivity indicated by the geophysics results;
- The principal observed features were located within depressions in the natural in the central and eastern areas of the trench. Features including the ditches and the stone deposits/surfaces appeared to show a broadly north-south orientation corresponding with the overall trend of the geophysics results;
- With reference to the stratigraphy, the earliest feature at the western end of the trench was the lower stone surface (2517). This was cut into the natural and associated with an eastern ditch. The base horizon of the surface produced Roman pottery;
- With reference to the stratigraphy, the earliest feature at the eastern end of the trench was a narrow compacted stone surface including burnt stone and quartz (overlain by the large stone (2503) and dark fill (2518) deposits which produced Roman pottery and assemblages of bone). This surface lay directly on the natural and was bordered on its eastern side by a 'U' profile ditch. An assemblage of 14 pieces of bone was recovered from the surface. It is not currently dated, but its composition (notably including the presence of burnt stone and quartz) presents some similarities to the Rotherwas Ribbon as observed in 2007, and contrasts in these respects with the other surfaces excavated in Trench 1.

3.2 Trench 2 (30m x 3m [see Appendix 1, Figure 2])

Trench 2 was located lower down the hillslope/to the north of Trench 1, but was still to the south of the 2007 'ribbon' excavation. The deposits of archaeological interest were focussed on a depression in the natural at the western end of the trench

The uppermost colluvial layer (3005) lay under the c.0.30m deep topsoil (3000). 3005 was c.0.30m in average depth, and consisted of a grey-brown sandy-silt. Within this deposit several sherds of Roman pottery were recovered. Cut into this layer at the east

end of the excavated area was a small channel (3001). This was visible across the width of the trench (Plate 6), and had a maximum width of 1m and a maximum depth of up to 0.40m. The fill of this feature consisted of a well-compacted orange-brown silty-clay with occasional large stones. Roman pottery was recovered from this deposit.



Plate 6: *Eastern ditch during excavation (© Herefordshire Archaeology).*



Plate 7: *Both upper (3006) and lower (3017) stone surfaces, separated by only a very thin band of colluvium (© Herefordshire Archaeology).*

Beneath the colluvial layer, a stone surface was identified. This stone surface (3006) consisted of a continuous deposit made up of small, both angular and rounded stone, and in places was up to 0.18m in depth. This surface in turn overlay a very thin layer of colluvium (3015) which contained a significant quantity of animal bone.

This layer of colluvium overlay a lower compacted stone surface (3017 [Plate 7]) associated with a ditch (3018 [Plate 8]). The ditch was “U” shaped, flat bottomed and was visible across the width of the trench. The ditch was cut into the natural clay and averaged 0.40m wide. The upper fill of the ditch consisted of a sandy-silt (3016) under which the primary fill (3019) consisted of a band of small angular stone.



Plate 8: *Western cut into the natural under excavation (© Herefordshire Archaeology). Cutting through both stone surfaces was a modern land drain (3020 [Plate 9]). This was also visible across the width of the trench, was c.0.25m wide and c.0.50m deep; it had steep straight sides and a flat base.*

The compacted surface consisted of angular weathered sandstone. Five pieces of flint were recovered from the matrix, with no other finds. The stone matrix was essentially a layer of single stone thickness (up to 0.1 metres thick), and sat directly on the natural. The surface was located within a cut (3021) into the natural (3022). This cut was visible



Plate 9: *Lower surface with partially excavated land drain 3020 (© Herefordshire Archaeology)*

Preliminary Assessment

- The majority of the features/contexts are associated with Roman pottery and are therefore of Roman or later date.

In terms of the project aims:

- The trench has established that the Stage 1 geophysics results in this area correctly indicated the presence of cultural deposits. However, no cultural or natural deposits were found which explained or coincided with the additional zone of higher conductivity indicated by the geophysics results;
- The principal observed features were located within a depression in the natural at the western end of the trench. Features including the ditches and the stone deposits/surfaces appeared to show a broadly north-south orientation corresponding with the overall trend of the geophysics results;

- With reference to the stratigraphy, the earliest feature was the lower stone surface (sealed beneath the upper stone surface with a thin layer of colluvium between the two, closely resembling the sequence in the central area of Trench 1). This surface consists of angular sandstone set within a cut or gully (with the stone lying directly on the natural at the base of the cut).
- The only finds from within or beneath this surface were five pieces of flint (from the matrix), and the surface is not currently dated.
- Two OSL samples were also taken during the excavation (one from the upper thick band of colluvium (3005) and one from the base of the trench). The latter sample in particular has the potential to date the lower stone surface. In addition, bone was recovered from the colluvial horizon overlying the surface (3015), and C14 dating of this material might provide a *terminus ante quem* for the lower stone surface.

3.3 Trench 3 (30m x 3m [see Appendix 1, Figure 2])

Trench 3 was located immediately north of the road and was the closest to the 2007 'Ribbon' feature (Sworn *et al* 2009). Given the inconclusive findings from Trenches 1 and 2 with respect to the project aims, and in order to maximise the likelihood of identifying a deposit of the same character as that found in 2007, the decision was taken to re-locate Trench 3 closer to the known length of the Ribbon than had been planned within the original Project Design. The trench was also positioned to test the geophysics anomalies in this area. The trench was 30m in length and 3m wide and as per the brief was excavated by machine down to the Ribbon or the natural gravels. As a consequence, the overlying stratigraphy was identified within the section, and recorded and sampled on this basis.

Underlying c.0.30m of topsoil (3500) was a 0.22m deep reddish-brown clay-silt subsoil (3501). Cut into this horizon was a modern drainage ditch (3509). This was 1.80m wide and 0.65m deep (cutting into the natural 3502) and was visible across the width of the trench. The fill of this feature (3508) consisted of a grey-brown silty-sand with occasional charcoal fragments, but was itself again cut by a later field drain (3504). The cut of this second drain was 0.60m wide and 0.50m deep and was again visible across the width of the excavated trench. The fill (3503) consisted of a dark grey-brown sandy-silt with a modern ceramic drain pipe at its base. A field drain (3516) also cut 3501. This field drain was 0.23m deep and 0.40m deep and was again visible across the excavated trench. The fill of this drain (3515) consisted of a grey-brown silty-clay comprising a mix of both subsoil and natural.

Underlying the subsoil (3501) was a 0.16m deep layer of a light grey-red sandy-silt (3513 [same as 3522]). Sandwiched between this and the subsoil was a small band, c.1.73 m wide and 0.14m deep, of a pinkish-orange re-deposited silty-clay with manganese flecks (3546 [same as 3521]). Cutting both 3521 and 3522 was a further linear ditch (3518). This ditch was 0.70m wide and 0.26m deep and was again visible across the width of the excavated trench. The fill (3517) was a red-brown silty-clay with rare manganese flecks.



Plate 10: *The curvi-linear ditch (3507/3512) at the east end of the trench (© Worcestershire Historic Environment and Archaeology Service)*



Plate 11: *The Ribbon (3514) and a section of the curvi-linear ditch (3507 viewed from the southeast (©Worcestershire Historic Environment and Archaeology Service).*



Plate 12: *The Ribbon (3514) and a section of the curvi-linear ditch (3507/3512) from the north (©Worcestershire Historic Environment and Archaeology Service).*

Underlying the 3513 was a very thin (0.02m) layer of a reddish-grey slightly silty-sand (3545) that was only c.2.05m wide. This in turn overlay a stone surface (3514 [Plates 11 and 12]). The stone surface was between 5 and 6 metres wide, and appeared to be part of a more extensive north-south aligned feature which had been cut obliquely by Trench 3. It had a closely packed 'metalled' appearance, and was mainly made up of rounded stones between 0.02m and 0.12m in length, and also contained some quartz pebbles and occasional fire cracked stone. The surface was shallow, being on average only two stones thick, and was uniform in character and thickness across its exposure within Trench 3. It was slightly inclined from east to west, with the total rise of 0.4 metres giving the western side a subtly embanked appearance. The western edge of the surface was sharply defined against the contrasting brown-pink natural into which it was cut, while the eastern edge appeared more diffuse against the rather different grey/brown gravelly natural exposed in this area (see below). 10 pieces of bone and two small pieces of pottery were recovered from the surface, and some of this material (including one piece of pottery) was sealed within the stone matrix.



Plate 13: *'Striped' natural clays and gravels underlying the Ribbon 3514 (© Worcestershire Historic Environment and Archaeology Service).*



Plate 14: *The machine cut deep section across Trench 3 viewed from the north-east. The base of the ranging rod lies on the mixed horizon which formed the base of the hollow at this point and which the Ribbon surface overlay, and the continuation of that horizon can be seen east of the hollow (nearest the camera) within the sectional exposure of the superficial geology (© Worcestershire Historic Environment and Archaeology Service).*

This surface lay within a shallow cut (3523) into the natural (3502/3550 [3551, 3552, 3553, 3545]), although it did not occupy the full width of the wider hollow. The natural generally consisted of a compact light brown-pink clay-silt with sand, with frequent manganese and occasional angular mudstone. This deposit was varied, and was found in roughly north-south aligned 'stripes' (Plate 13), the majority of which were located under the stone surface. The first (3502) consisted of a compact light brown-pink clay-silt with sand and this overlay a firm yellow-brown silty-clay (3554). The second (3550) was a compact blue-yellow clay with frequent gravel. The third 'band' of natural (3551) was a firm yellow-brown silty-clay with gravel and the fourth (3552) was a grey-brown silty-sand. The last natural deposit (3553) underlying the surface was a friable brown-red silty-clay with evidence of gleying where the deposit changed colour to a mottled green-blue.



Plate 15: *The substantial ditch 3520 viewed from the north (© Worcestershire Historic Environment and Archaeology Service).*

At the conclusion of the hand excavation (and following the 100 % removal/sampling of the stone surface) a 15 metre long section of the trench incorporating and extending either side of the area where the stone surface had been located was subject to further deep trenching by machine (Plate 14). The trench was dug to a depth of up to 3 metres below the base of the cut for the stone surface (representing the maximum depth technically possible with the machine). As observed within the limits of the deep trench, the horizon on which the stone surface lay formed a continuous undulating band within the superficial geology, and as such extended as a visible layer into the undisturbed natural clay deposits to the east and west of the cut/hollow 3523 (i.e. the creation of the cut/hollow had locally exposed this horizon prior to the laying/deposition of the stone

surface on top of this exposure within the area of the cut). The underlying bedrock was not reached within the depth of the deep trench, but the superficial geology essentially comprised a continuous deposit of glacial clays throughout the depth of the observed section.

Cutting the natural 3502 was a substantial north-south aligned linear ditch (3520 [Plate 15]). This ditch was aligned roughly north-south, it was 1.22m wide and 0.50m deep and was visible across the width of the trench. The fill (3519 [same as 3532]) was a grey-brown clay-silt with rare rounded and cracked stone.

Preliminary Assessment

- The principal observed features were associated with a broad colluvially filled depression in the superficial geology;
- In terms of the stratigraphic sequence, the latest feature (excluding the recent drainage ditch and associated field drain) is the curvilinear ditch 3512, which cuts ditches 3518 and 3520, which cut the colluvial silts overlying the stone surface and its associated cut/hollow;
- The observed features in Trench 3 are not provisionally dated by association with closely diagnostic artefact material.

In terms of the project aims:

- The trench has established that the Stage 1 geophysics results in this area correctly indicated the presence of cultural deposits;
- Excepting the east-west aligned curvilinear ditch, the principal features (Ditches 3518, 3520 and the stone surface and associated cut) appeared to show a broadly north-south orientation corresponding with the overall trend of the geophysics results;
- Ditches 3518 and 3520 (which produced no artefact dating evidence or other finds) may be held to broadly resemble in character and stratigraphic position (late in the hollow infill sequence) the similarly aligned late prehistoric/Roman features recorded a short distance to the south in the 2007 excavation. However, it should be stressed that this association/connection is not proven by direct evidence;
- The stratigraphically late curvilinear ditch (which produced no artefact dating evidence or other finds) is of a distinctive steep sided and flat bottomed form, runs on an east-west rather than a north-south alignment (at least as observed within the area of Trench 3), and is generally of a markedly different character to any other ditches observed either in the present project or in the 2007 Rotherwas Access Road investigations;

- Across a range of specific comparative criteria (stratigraphic pattern of the overlying silts, nature and composition of the surface, association with the cut/hollow in which it sits, associated pottery and bone), the ‘metalled’ stone surface closely resembles the Rotherwas Ribbon as observed in 2007. Given its additional coincidence of alignment and proximity to the northern extremity of the Ribbon as excavated in 2007, it is reasonable to conclude with a reasonable degree of certainty that this is an extension of the same feature;
- The addition of the Trench 3 surface to the 2007 section of the Rotherwas Ribbon means that a continuous Rotherwas feature of 82 metres is now known. The feature evidently continues to the north of Trench 3;
- The closely packed surface included a significant quartz component (as in 2007), and also some burnt stone. Although there was a lower incidence of burnt stone than was present in much of the Ribbon as observed in 2007, the proportion was consistent with the similar lower density observed at the southern end of the 2007 Ribbon excavation. This combined pattern (inclusive of the 2007 evidence) may begin to delineate a significant pattern of compositional variation along the known Ribbon feature as a whole;
- Throughout Trench 3, the Ribbon surface/deposit was of uniform thickness and character, and inclined slightly from west to east (resembling in this detail the embanked/undulating appearance of the Ribbon as observed in 2007);
- Pottery and bone were recovered directly from the surface of the Ribbon (as in 2007). In addition the full excavation of the area of surfacing within the trench resulted in the recovery of a pottery sherd and bone sealed within the stone matrix;
- The general character of the cultural material recovered from the Ribbon is comparable to that found in the 2007 excavations (and, proportional to the area of exposure, was also comparable in quantity), although flint was not recovered from the surface in Trench 3;
- As in 2007, the surface was observed to be located within a cut/hollow of uncertain origin which it did not completely occupy;
- Within the cut/hollow, the stone surface/Ribbon lay directly on the underlying natural (i.e. there was no silt/colluvial deposit between the base of the Ribbon and the natural). The particular natural exposure on which the Ribbon lay consisted of a mixed gravel rich horizon which was observed to extend as a distinct layer into the adjacent areas of the undisturbed superficial geology east and west of the ribbon cut/hollow. No stone layer was observed overlying this horizon in the undisturbed natural beyond the cut/hollow;
- It is reasonable to conclude that stone surface was deposited on the underlying natural deposit after the latter had been exposed by the formation of the cut/hollow.

Moreover, the absence of intervening silt or colluvial horizons between the two contexts tends to suggest that the stone surface was deposited/created either as part of a continuous process which also created the hollow, very shortly after the formation of the cut/hollow, or following later cleaning/scouring of the hollow (by whatever mechanism) back to the underlying natural (although it should be stressed that no archaeological evidence was observed which supports such a re-cut scenario);

- Since the stone surface/Ribbon is associated with cultural material (both from its surface and from within the matrix), and the ‘striped’ pattern of the underlying natural deposit appears consistent with peri-glacial cryoturbation processes in an Ice Age context, then it can be reasonably suggested that there is a long time gap between the formation of the underlying natural deposit and the subsequent creation of the cut/hollow and associated stone surface/Ribbon deposit;
- Five OSL samples were taken from within Trench 3. In combination, three of these samples may help date the Ribbon specifically (subject to the viability of those samples), and to test the chronological associations of the deposit sequence of which the Ribbon is a part. The first sample was taken from the layer immediately above the Ribbon, the second from the Ribbon itself and the third from the natural underlying it.
- In addition, radiocarbon dating of the bone sealed within the stone/Ribbon deposit potentially allows a *terminus-post quem* for the creation of the Ribbon to be established/confirmed;
- The 3 metre long exposure of the Ribbon in Trench 3 did not provide additional evidence of some features which were noted in the 68 metre 2007 Ribbon excavation. No nearby pits were identified in the present excavation, no area of ‘secondary/upper’ surfacing was found, no areas of charcoal staining/deposition were found, and the ribbon hollow was not observed to cut earlier cultural features. Project aims concerning further detailed assessment of these specific details as observed in 2007 cannot be directly pursued via the Trench 3 evidence;
- Given the very limited exposure of the Ribbon in Trench 3, it cannot be said that the localised absence of such features necessarily distinguishes the character of the Ribbon in the vicinity of Trench 3 from the Ribbon as observed in 2007 (where these features were also only present in some places).

3.4 Trench 4 (30m x 3m [see Appendix 1, Figure 2])

Trench 4 was located north of Trench 3 on the edge of a significant east-west break of slope/terrace feature (Figure 2). It was positioned not only to identify the possible continuation of the Ribbon feature, but also to more generally test the geophysics responses in this area, and to provide evaluation coverage in the middle of the northern field. This trench was 30m in length and 3m wide. As per the brief, it was excavated by

machine down to the Ribbon or natural deposits. As a consequence of this method of excavation, the overlying stratigraphy was identified within the section, and recorded and sampled as necessary.



Plate 16: *Ditch (4019) on the east side of the depression as viewed from the east (© Worcestershire Historic Environment and Archaeology Service).*

Underlying c.0.35m of topsoil (4000) was a 0.55m deep mid-brown silty-sand subsoil (4001 [same as 4020]). This in turn overlay a 0.12m deep gleyed subsoil (4031). Under the sub-soil (4031) was an interface/diffuse change (4003 [same as 4004]) between the colluvial/alluvial layer (4002) and the overlying gley (4031). This was a sterile layer of mid brown silty-clay with blue-grey mottling, and contained 1 flint flake and 22 sherds of Roman pottery.

Underlying this at the west end of the trench was a level area of loose unsorted stone (4028) up to 0.10m thick. This in turn was cut by a north-south aligned depression (4038) which more broadly lay within the natural sands and gravel (4034, containing frequent manganese flecks). The depression (4038) was 8.80m wide and 0.65m deep, and was filled by a colluvium/alluvium deposit (4002). This consisted of a firm yellow-brown sandy-clay that became sandier with depth. A significant quantity of flint flakes were recovered from the upper horizons of this fill (Plate 17).

Context 4034 (natural sands and gravels with manganese flecks) overlay a lower natural layer (4035) consisting of a very firm red-pink silty-clay with pale green-blue clay mottles and very occasional small sub-rounded stone. These horizons were cut by a

channel with a probable re-cut and a complex set of fill deposits. The initial channel (4033) cut through 4034 and down to the top of 4035. This channel cut is c.0.71m deep and 7.94m wide and is visible across the width of the excavated trench. The fill (4032) consisted of a brown-orange firm silty-clay with sand that proved to be sterile.



Plate 17: *Part of the flint flake spread uncovered during the excavation of channel fill 4002 with edge of the stone spread 4028 just visible on the right (© Worcestershire Historic Environment and Archaeology Service).*

This fill was re-cut by channel 4027 (Plate 18). The channel cut was 6.84m wide by 0.73m deep and was visible across the excavated trench. The fills of channel 4027 were varied and complex, and will be best described via specialist geomorphological analysis - what is of immediate provisional note is that all the fills appear to be deposited from the west. The base fill (4008) consisted of a stony layer with a grey-blue sand matrix. The stones were poorly sorted and included predominantly small sub-angular/rounded stone with occasional broken stone and even fewer quartz fragments. It should be noted is that this horizon was very loose and unconsolidated. A second small truncated area of stone (4011 [Plate 19]) was also noted against the east side of cut 4027. This was a loose deposit, but was more cohesive than 4008, and consisted of small/medium sub-angular and rounded stone in a light blue-grey coarse sand with occasional quartz pebbles. Within this deposit both flint flakes and bone were recovered.

Overlying this and partially overlying 4008 at the east end was a deposit that filled the remainder of cut 4027. This deposit (4009) was up to 0.47m thick and consisted of a mottled layer including light grey and light yellow-brown sandy-clay with very

occasional charcoal flecks. The next fill (4007) directly overlay the base stony deposit (4008), and butted fill 4009. This was a 0.19m thick layer of light grey-brown silty-clay with sand and only very occasional small rounded stone and charcoal flecks. Overlying this was a further 0.24m thick fill (4006) comprising light blue-grey silty-clay, with occasional small rounded stone (but without the charcoal flecks which characterised the underlying 4007 deposit). Overlying both 4006 and the previously mentioned 4009, was a silty clay deposit (4005) which formed a very firm red-brown layer with grey mottles and occasional sandy patches. Overlying this was a 0.34m thick band of pure sand (4023), which, unlike the underlying horizontal deposits (4005, 4006, 4007 and 4008), sloped down from west to east, and as a result overlay both 4005 and 4006. The last “angled” fill, 4024 overlies not only 4023, but also the western edge of the cut 4027. This fill forms a 0.36m deep horizon consisting of a grey-brown firm silty-clay with occasional charcoal flecks and several flint flakes. This sequence of slanting fills was finally overlain by blue-grey silty-sand layer colluvial/alluvial interface layer 4004/4003 which sealed the channel depression as a whole (see above), and which was hereabouts only 0.10m thick.



Plate 18: *Significant depression (4027) in base of trench viewed from the northeast (© Worcestershire Historic Environment and Archaeology Service).*

Immediately to the east of channel cut 4027 was a complex of three ditches on a north-south alignment. The upper two ditches (4013 and 4019) were cut from the gleyed subsoil 4031. The latest ditch (4013) was 1m wide, 0.23m deep, and was visible across the width (north-south) of the excavated trench. This was filled by a brown-red silty-clay with some rounded pebbles and charcoal flecks (4012). No finds were retrieved from this deposit.

Ditch 4013 was cut by the second linear ditch (4019), which effectively appears to be a re-cut of ditch 4013. This ditch was 1.78m wide and 0.36m deep, and was visible across the excavated area (which in this instance was 2.80m due to health and safety considerations). The primary fill (4014) was only c.0.10m deep and consisted of a light blue-grey silty-clay with sand which (interestingly) lined the eastern side of the cut ditch edge (4019 [Plate 16]). The second fill (4015) also entered the ditch from the east and consisted of a 0.36m deep orange-pink silty-clay - again no finds were recovered from this horizon. The last fill (4016) had a maximum depth of 0.28m and consisted of a grey-brown clay-sand with rare sub-rounded and angular stones and charcoal flecks.



Plate 19: *Small linear spread of gravel ([4011] © Worcestershire Historic Environment and Archaeology Service).*

Ditch 4019 cut the upper fill of the third ditch in the sequence (4022). This ditch (4022) was cut into the natural clay forming the side of the channel cut, and was stratigraphically later than the main channel cuts and the stone deposits 4008 and 4011 previously described. Ditch 4022 was 0.93m wide by 0.44m deep, had a 'U' shaped profile, and was visible across the excavated trench. The fill (4021) was a compact mottled grey-yellow silty-clay. Within this horizon was a small quantity of sub-angular and angular stone, as well as large sub-rounded stones, and some charcoal fragments and flint flakes. This fill continues to the east (out of the channel) as a horizontal layer overlying the natural (4002 and 4010).

It should also be noted that three field drains ran on a north-south alignment across Trench 3. These cut into the gleyed subsoil, and were the latest features observed in the trench.

Preliminary Assessment

- The principal observed features were associated with a broad colluvially sealed depression in the superficial geology. The particular build up of overlying colluvium at this point (associated with the east-west terrace/break of slope) means that this depression is now deeply buried;
- A principal channel (4033) with a complex deposit/fill sequence (including subsequent channel re-cut 4027) ran on a broadly north–south alignment (although the channel appeared to have been cut obliquely by the trench, suggesting a south-east to north-west course). This channel sequence was sealed by - and therefore pre-dates - an upper colluvial/alluvial interface horizon (4003/4004) which produced one flint flake and twenty-two sherds of Roman pottery. Channel 4033 cut - and is therefore later than - the shallow depression (4038) which produced a large assemblage of flints from a spatially limited area of the upper fill (4002);
- At the base of the principal channel complex, two thin spreads of loosely consolidated mixed stone and gravel (4008 and 4011) overlay the natural, and one of these (4011, eastern side of channel re-cut 4027)) produced one flint and one piece of bone;
- The principal channel (comprising 4033 and recut 4027) was bordered on its eastern side by a sequence of three ditches on a broadly north-south alignment. The earliest ‘U’ profile ditch (4022) cut into the natural, but stratigraphically post-dated the channel cuts and basal stone deposits, and therefore dates from a period when the channel silting process had begun. The second ditch (4013) cut the upper fill of 4022, and this was in turn cut by the third ditch 4019 (which essentially appears to be a recut of 4013). Ditches 4013 and 4019 were both cut from the gleyed subsoil which overlies the colluvial/alluvial interface deposit 4003/4004, and therefore date from a late point in the deposit sequence after the principal channel complex had become infilled;
- None of the ditches produced direct artefact dating evidence (or any other finds).

In terms of the project aims:

- The trench has established that the Stage 1 geophysics results in this area indicated the presence of features with cultural associations;
- The principal features (hollow with channels including basal stony deposits and spatially associated ditches on the eastern side of the channel) appeared to show a broadly north-south orientation corresponding with the overall trend of the geophysics results;
- The observed nature of the channel and the fills and deposits within it appears consistent with down-slope water action/alluvial processes, associated water borne

deposition of the primary fills (including the two loose stone spreads in the base of the channel), and a subsequent period of more gradual alluvial and colluvial silting;

- The Trench 4 channel feature does demonstrate the importance of drainage/alluvial processes in this part of the Rotherwas landscape in earlier prehistory, and as such indicates that such processes may be relevant to the understanding of other features in the immediate landscape, and to the nature and spatial focus of cultural activity in the locality;
- The combined stratigraphic evidence and artefact evidence currently tends to indicate that the principal channel complex came into being in a Mesolithic/Neolithic context (as suggested by the apparent *terminus post-quem* established by the flint assemblage sealed within context 4038) and that the infilling of the feature had most likely occurred by the Early Medieval period (as suggested by the Roman pottery assemblage from the alluvial/colluvial interface context 4003/4004). The fact that stony layer 4011 included a flint flake and a piece of bone appears consistent with this suggested sequence (and at least demonstrates that this particular deposit formed after significant cultural activity had begun in the surrounding landscape);
- The character of the deposits within the channel (including the two loose stone spreads in the base of the channel) provides an important comparison with the nature of the deposits (including the stone surfaces) variously observed in Trenches 1,2,3, 5 and the 2007 Ribbon excavation (and with the deposit sequence in the large palaeochannel recorded to the west during the 2007 Rotherwas Access Road project). Collectively, this resource of comparative data potentially provides an important key for both a more sophisticated general evaluation of the relative interplay of natural and cultural processes in the Rotherwas buried prehistoric landscape, and a better specific understanding of the origin of the deposit sequence in each of the excavated trenches;
- One important specific comparison is between the basal stone deposits in Trench 4 and the Ribbon deposit as observed in the 2007 excavation and in Trench 3. Although the mixed stone size, sorting pattern, and the loose and unconsolidated makeup of the Trench 4 deposit is entirely different to the character of the Ribbon contexts (and immediately suggests a very different formation process/origin), it is interesting that contexts 4008/4011 directly overlay the natural (as with the Ribbon surfaces within their hollows), and that 4008 in particular included small sub-angular and rounded stone as well as a small quantity of quartz pebbles (again echoing the lithological makeup of the Ribbon). That lithological similarity might reflect a common geological source, or it could even more directly result from erosion and re-deposition of stone materials derived from an up-slope Ribbon like context;
- The origin of the Trench 4 channel feature cannot be certainly inferred from the available evidence. The channel may be entirely natural, its creation may indirectly reflect changes in local drainage patterns caused (intentionally or otherwise) by nearby human activity, or it may directly begin as a wholly or partly cultural feature

which is then modified by alluvial processes – or, indeed, some combination of any or all of these may be true.;

- The course of the channel beyond Trench 4 is not known, and in so far as any significant judgement can be made from such a short exposure of the feature, its trend appears south-east to north-west. The deep masking of the feature by subsequent colluvial deposition in this area demonstrates the difficulty of attempting to track (or understand the formation of) such a feature via reference to a current micro-topography which is evidently significantly altered from the surface landform present in prehistory;
- The association of the channel with the later ditches on its eastern side does, however, suggest that the partly in-filled channel remained a significant landscape feature into the later prehistoric and Roman landscape (or perhaps that its former alignment became fossilised within later settlement patterns). The ditches are not dated, but the 'U' profile of the earliest ditch (4022) might be judged consistent with a prehistoric origin (perhaps later prehistoric given its stratigraphic position??), while ditches 4013 and 4019 are cut from high in the stratigraphic sequence (and cut through the Roman pottery associated context 4003/4004), suggesting a Roman or later date);
- It should also be noted that the presence and pattern of the later ditches does echo, at least superficially, the somewhat similar ditch sequences in Trench 3, the 2007 Ribbon excavation, and Trenches 1 and 2. Nevertheless, no direct association between the Trench 4 ditches and those in the up-slope trenches can be demonstrated at this point (nor, of course, can any relationship be more generally demonstrated between any of the ditch sections identified in any of the different trenches). Given that the five evaluation trenches collectively offer only 'keyhole' access to what is evidently a complicated set of features spread over a large area, any simplistic attempts to 'join up' disparate (if broadly similar) linear contexts probably has more potential to mislead than enlighten;
- The suggested relative sequence in Trench 4 may be tested and enhanced in absolute dating terms via the OSL dating samples taken from this trench. One was taken from the natural below 4008, one from the layer (context 4002) through which the principal channel was 'cut', and one from the uppermost alluvial fill of the channel.

3.5 Trench 5 (25m x 3m [see Appendix 1, Figure 2])

Trench 5 was located at the northern extent of the research area (Figure 2). It was placed with respect to the geophysics responses, and the possible extension of the Ribbon suggested by those responses. Since the trench also lay immediately to the south of (and within the same topographical context) as the adjacent Rotherwas Futures site where prehistoric deposits had been recovered during recent archaeological work in advance of

development, it also potentially allowed the interface between the Ribbon and the Futures deposits to be assessed.



Plate 20: *Section showing the location of the upper surface and plough damage (© Herefordshire Archaeology).*

The trench was 25m in length and 3m wide and, as per the brief, was excavated by machine to the Ribbon or the natural gravels. In the event, significant features were subsequently observed in section on the northern side of the trench. Since these features were evidently integral to the understanding of the primary archaeological sequence within the central area of the trench, a localised 4 x 1 metre northern extension was excavated by hand to permit their further investigation.

For the purpose of this summary, the trench description is divided into two sections. The first section describes the central area of the trench where a series of overlying surfaces were encountered at the eastern end of a broad depression in the natural gravels. The second section describes the eastern area of the trench where a complex of pits were found cut into the surface of an adjacent rise in the gravels.

Central Area

Three overlying stone surfaces were excavated at the eastern end of a depression within the gravels. The surfaces all varied in their size and make up, and are separated by bands of buried soil and colluvium which had progressively accumulated within the hollow (so burying each successive surface in the process).



Plate 21: *Section through the pit underlying the upper stone surface (© Herefordshire Archaeology).*

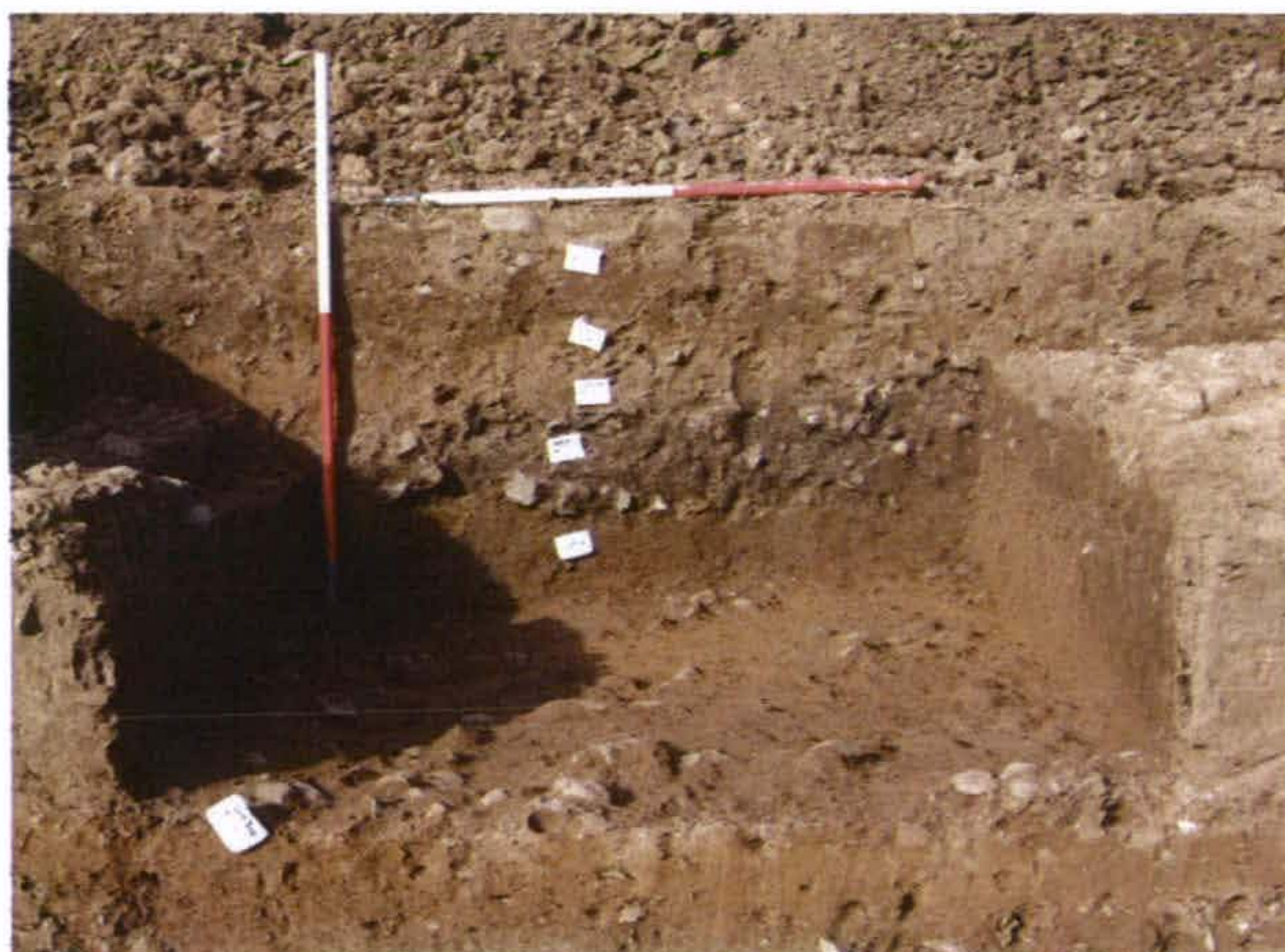

Plate 22: *Section showing the location of the second surface (base of upright ranging Pole [© Herefordshire Archaeology]).*

Plate 23: *Detail of the second surface (© Herefordshire Archaeology)*

Just to the east of the main surface, and also cut into the buried soil (4507), was a second contemporary pit (also initially identified in section). This was 0.30m wide and 0.22m deep (truncated). Importantly, the pit produced dating evidence in the form of a small sherd of pottery.

Underlying the stone surface (and cut into by the pits), was a buried soil (4507). This horizon appeared to occupy a hollow, and accordingly rose to the west and east of the stone surface to form the adjacent subsoil. The buried soil (4507) had a maximum depth of 0.40m, and overlay a second stone surface (4534). This second stone deposit (4534 [Plate 22]) was visible in section for a distance of c.4m and consisted of a narrow

(c.0.08m) band of both rounded and angular stone (c.0.02m x 0.06m) which formed a solid, but not completely continuous surface (Plate 23).



Plate 24: *Detail of the lowest surface and the cut (right edge) into which it was laid (© Herefordshire Archaeology).*

Underlying the second surface was a second buried soil (4532). Like the upper buried soil, this soil appeared to fill a hollow, and showed a similar rise to the east and west such that it firstly extended beyond the second surface to underlie the upper buried soil (4507), and then continued beyond the margins of 4507 to form the subsoil throughout the rest of the trench. Because buried soil 4532 extended beyond and rose above the second stone surface (4534), soil creep/erosion had caused some of this deposit to fall back over the eastern edge of that surface, creating an apparent effect of partial burial by the ‘underlying’ deposit.

Throughout the majority of the excavated area, buried soil 4532 was underlain by the natural superficial geology (4523). The natural consisted of near vertical bands of gravel and clay which are provisionally considered to be the result of peri-glacial cryoturbation processes. As revealed with the full length of Trench 5, the surface of the natural clay and gravels gently undulated, and it is this natural undulation which appears to be the origin of the hollow which the surfaces and associated buried soils sit within.



Plate 25: *An area of levelling and the underlying small pits to the east of the main excavation. One still filled with stone (4526) and in front of it an excavated pit, 4524 (© Herefordshire Archaeology).*

At the eastern end of the hollow (i.e forming part of the vertical sequence which included the upper stone surfaces), buried soil 4532 overlay the third and lowest stone surface (Plate 24). This surface (4515) was aligned roughly northwest-southeast and was 1.60m wide and 0.12m thick. The surface was continuous and compacted, and consisted of abundant, mainly rounded, stone (0.05m x 0.05m) with occasional quartz and sandstone fragments. The surface lay directly on the underlying cryoturbated natural (4523). Where the natural clay rose on its eastern side, the surface was cut into the side of the hollow creating a sharply defined 'stepped' edge (Plate 24).

Eastern Area

The archaeological features at the eastern area of the trench were spatially associated with the surface of the rise in the natural which extended east of the central area/hollow (Plate 25). This higher area was sealed by the eastward continuation of the buried soil 4532 (the lower buried soil within the central area stratigraphic sequence) which hereabouts formed the subsoil.

The soil horizon overlay a levelled stone surface (4519). This surface was visible across the width of the trench, and was c. 4m wide with diffuse eastern and western edges. The

surface showed a tangible contrast to the adjoining exposures of natural gravel, and in comparison to the natural gravel was characterised by an abundance of larger rounded stones and occasional charcoal flecks.

Underlying the surface were three small pits. The first (4524) measured c1m in diameter and had gently sloping sides to a depth of 0.28m, and a slightly concave base. The fill of this feature (4527) was not dissimilar to the 'subsoil' above, although there was a higher silt content, and both charcoal and small fragments of pottery were retrieved from the base. The second pit (4526) immediately adjoined 4524. It was oval in shape measuring c.0.55m (north-south) x 0.30m (east-west), but was otherwise similar in profile and depth to pit 4524. However, unlike pit 4524, no charcoal or finds were recovered from pit 4526. The third pit (4518) was located immediately to the west of 4526. It measured c.0.70m in diameter and 0.33m deep. Again, no finds were recovered from this pit.

Preliminary Assessment

- The principal observed features were spatially associated with a broad depression in the natural, and were located within the eastern end of that depression and on the rise in the gravels immediately to the east of the depression;
- The character and artefact associations suggest that the archaeological deposits in this trench are of prehistoric date, probably Bronze Age and earlier (the probable burnt mound in itself suggests a Bronze Age date - compare with the similar features from the immediately adjacent Futures site);
- In terms of the stratigraphic sequence, the latest feature within the main hollow is the upper stone surface/burnt mound deposit, which overlay two pits (including one directly under the surface with a charcoal rich fill). These features seal a buried soil and a second stone surface, which itself seals a lower buried soil and a third stone surface. The latter occupies a cut into the natural, and was associated with cultural material including bone and flint;
- At the higher eastern end of the trench, the extension of the lower soil (which hereabouts formed the subsoil) sealed a further area of stone surface, and this overlay a sequence of three inter-cutting pits, the latest of which produced a small pottery assemblage;
- The lower soil horizon forms an important reference point in the stratigraphic sequence. Since the lower stone surface in the main depression, and the stone surface and pits at the eastern end of the trench, are all sealed by this horizon, they predate it and may be regarded as a very broadly contemporary group of features. Likewise, since the burnt mound like deposit, its associated pits and the second stone surface all overlay this horizon, they post-date it and represent later phases of activity which nevertheless appear to be prehistoric in date. It should additionally be noted that the second stone surface and the upper burnt mound surface are themselves separated by

a time period sufficient to allow the accumulation (by whatever mechanism) of the upper buried soil over the second surface;

- The natural exposure of the superficial geology in this trench consisted of banded gravels and clays which are provisionally considered to be the result of peri-glacial cryoturbation processes. The naturally undulating profile of these deposits appears to be the origin of the central hollow and adjacent eastern rise which the archaeological deposits are associated with.

In terms of the project aims:

- The trench has established that the Stage 1 geophysics results in this area correctly indicated the presence of cultural deposits;
- Features including the second and lower stone surfaces in the central hollow appeared to show a broadly north-south orientation corresponding with the overall trend of the geophysics results;
- The deposits include a sequence of stone surfaces and associated features which do in some ways resemble the 2007 excavation/Trench 3 Ribbon sequence. Most obviously, the lowest surface consisted of a consolidated stone deposit (4515) which includes burnt stone and quartz in the matrix, which occupies the eastern edge of a broader hollow, which sits directly on the natural within a cut which is sharply defined on its eastern side, and which is associated with flint and bone. The surface did not produce diagnostic artefact dating evidence, and is not positively dated;
- In terms of the stratigraphy, surface 4515 is broadly contemporary with the adjacent surface (4519) on the gravel rise immediately to the east, and the inter-cutting pit group (including the prehistoric pottery assemblage from the latest pit) which is sealed by surface 4519. The inter-cutting pit group resembles similar pit groups recorded during the Rotherwas Access Road excavations which were dated via associated pottery to the late Neolithic/Early Bronze Age;
- It should be noted that surface 4519 is the only surface from Trenches 1-5 (or from the 2007 Ribbon excavation) to be identified outside the context of a channel/hollow/cut. As such, it demonstrates that stone surface creation was occurring in a range of contexts in the prehistoric Rotherwas landscape. Since surface 4519 seals the pit group, and butts against the adjoining natural gravel exposures, it does appear to be a direct product of deliberate cultural action, and cannot be easily explained in this situation by any notional natural formation process;
- The relationship of the lower surface 4515 and the second surface 4534 (with the lower buried soil 4532 between) resembles, at least superficially, the pattern of the upper and lower surfaces observed in the 2007 Ribbon excavation. However, in Trench 5, there is an evident difference in character between the two surfaces (the 'upper surface' is not fully continuous, and does not include quartz and burnt stone),

and the intervening horizon (comprising a buried soil) differs from the silt horizon observed in 2007;

- The re-deposition of the adjacent burial soil onto the eastern side of the second surface does demonstrate that this surface (4534) was exposed (and visible) for the period of time while such marginal weathering processes occurred;
- The upper stone surface and associated pits can be provisionally interpreted as a burnt mound complex comparable to similar burnt mounds known from the immediately adjacent Rotherwas Futures site and other places within the Rotherwas locality (e.g, recent excavations at Redhill and Bullinghope). The sealing of Trench 5 by these features provides an important stratigraphic, chronological and cultural reference point for the Trench 5 sequence (and apparently ties that sequence into the Futures complex);
- It may be significant to note that Trench 5 lies at the topographical interface between the valley side and the flood plain, and that situation is reflected in the deposit sequence by the relative absence both of colluvial accumulation (as compared to the up-slope trenches) and of alluvial accumulation /sealing (as compared to the deposit sequence within the Rotherwas Futures site);
- The principal hollow within Trench 5 (which the archaeological deposits relate to) is of uncertain origin, but most likely reflects natural undulation within the superficial geology;
- The partial exposure of the natural gravels within Trench 5 – within an alternating north-south aligned sequence of ‘striped’ clay and gravel deposits within the superficial geology which appears to have been created by peri-glacial cryoturbation - does raise some further questions about the exact context of the sequence of secondary stone surfaces within the trench. While it is clear from the stratigraphy that none of the various secondary surfaces are directly linked to this peri-glacial action (they originate in a much later chronological context in association with cultural activity and episodes of Holocene soil deposition), it is interesting that the surfaces do spatially relate to and sometimes butt up against natural gravel exposures. Particularly if the Trench 5 surfaces are seen to be a deliberate product of cultural action (which seems wholly or partly likely on present evidence), then the relationship to adjacent natural gravel exposures may very well be significant in either functional or, indeed, representational terms (or both). The patterns within Trench 5 open the important possibility that natural gravel surfaces are being actively recognised, incorporated and used within wider patterns of cultural activity, and that has obvious potential relevance for the broader understanding of the Ribbon;
- Further dating evidence for the Trench 5 sequence is potentially provided by specialist analysis of the prehistoric pottery, by analysis of the two OSL samples from this trench (which were taken from the natural below surface 4515, and from the buried soil (4532) above 4515), and by radiocarbon dating of charcoal samples

from the pit beneath the burnt mound/upper surface, and the bone material from surface 4515.

3.6 Preliminary Discussion/Findings

General Observations

- Collectively, the five trenches all produced archaeological and deposit patterns which show a certain degree of generic similarity, and that in itself was an interesting result. In particular, each 30 metre trench showed a restricted distribution of areas of archaeological interest, with a focus in each case on buried hollows/channels (apparently showing a broadly north-south alignment) where cultural and depositional activity was observed, and where, in particular, patterns of stone surfaces/deposits and ditches were noted (and with very little archaeology observed beyond or between these hollow/channel features);
- Such a pattern is not by any means a commonplace one in the archaeological record generally (compare, for example, the character of the deposit sequences recovered over the last 25 years at Wellington Quarry, albeit in a flood-plain context), and nor was this precise pattern observed elsewhere in the immediate locality along the 1.6 km east-west landscape transect provided by the Rotherwas Access Road, or within the flood-plain located Futures site to the north (although burnt-mound like stone spreads were found at the Futures site). The apparent implication is that there is something specific ‘happening’ in this particular area (and perhaps on this particular overall north-south alignment, and across this particular intermediate valley side topographical zone), that this influences settlement activity in this area over a long period of time, and that the Rotherwas Ribbon (however understood) in some way fits within (or marks the beginning of?) that particular pattern;
- On the face of it that general pattern might seem entirely relevant to building better understanding of the Rotherwas Ribbon as observed in 2007 (which itself consisted of a north-south aligned linear stone surface feature set within a hollow/channel and associated with later ditches). However, what is equally apparent is that the specific character and chronology of the deposits showed very significant differences across the five trenches, and by no means exhibited a straightforward connection with the Rotherwas Ribbon (or, for that matter, a straightforward connection between the specific deposits and features between any given trench and the next);
- Notwithstanding the overall north-south alignment of many of the features in the trenches (principally hollows, surfaces, stone deposits and ditches), and the nominal similarity and stratigraphic position of some of the features, it is not straightforward to attempt to spatially ‘connect up’ features from one three metre wide trench to the next. In fact, to notionally do so across such a large area with unknown intervening deposit sequences is potentially highly misleading, and cannot be sustained by direct evidence. In the case of Trench 3, where the ‘Ribbon’ deposit was spatially close to

the 2007 Ribbon exposure, such a connection has been made, but even in that instance it is an assumption;

- Although the results from Trenches 1-5 may tend to suggest that this particular corridor is, for whatever reason, a significant focus of cultural activity over a long period of time, there is clearly a danger that very limited ‘keyhole’ investigation of just that presumed corridor – in fact just one part of a mid-slop zone where widespread cultural activity would be expected - may be creating something of a false ‘self-fulfilling prophecy’ effect in this sense. The relationship of the geophysics survey evidence to the Trench 1-5 deposits which were subsequently observed is not straightforward (see Appendix 2), and the deposit sequence beyond the areas of interest indicated by the geophysics has not been tested (except, of course, within the Access Road corridor - excepting the large palaeochannel to the west – it is relevant to note that no comparable features were actually observed east and west of the Ribbon);
- A significant site-formation process issue is the uncertain effect of later truncation in this landscape. This mid-slope zone has been subject to intensive arable agriculture from at least the medieval period onwards (see, for example, the relic medieval field-system recently identified to the west by Lidar survey). The particular area of the Ribbon has additionally been subject to sustained late 20th century arable intensification, and colluvial accumulation in the form of defined east west-terraces (including the one now occupied by the Access Road) is perhaps a consequence of these long-term agricultural processes. Elsewhere along the Access Road corridor, only deeply cut prehistoric features (post-holes and pits) survived archaeologically, and the floor horizons etc of the presumed Beaker house to the west had been completely removed even despite relatively deep (post-Medieval?) colluvial burial (Sworn et al 2009). In other words, differential survival/preservation of features which happen to have been associated with buried hollows/channels– and which were perhaps originally associated with much more varied patterns of cultural activity across adjacent landscape zones – may be giving those features a disproportionate apparent significance;
- These combined caveats – effects of later truncation, limited ‘keyhole’ investigation in some degree based on prior assumptions, potential for additional cultural deposits in areas which were not sampled, limitations of spatially dispersed trenching as a mechanism for tracking and defining potentially complex and extensive features – also need to be generally borne in mind when developing any broader overview of what has or has not now been demonstrated with respect to the probable extent and character of the Rotherwas Ribbon . Indeed, it remains possible that surviving extensions of the twisting 2007 feature were actually entirely missed within the trenching exercise.

The Ribbon in Trench 3

- On the (apparently reasonable) assumption that a further length of the Rotherwas Ribbon was identified in Trench 3, 87 metres of the Rotherwas Ribbon is now known;
- The stone surface was of closely similar width, form and apparent composition to the 2007 exposure, and presented a densely packed ‘metalled’ appearance;
- The stone surface contained cultural material within, as well as from the surface of, the matrix (bone, pottery, and some burnt stone), and logically can therefore only have formed in a context where significant cultural activity was occurring (i.e. from the Neolithic period onwards);
- Although presumed fire cracked and burnt stone was present in the surface in Trench 3, there appeared to be a lower incidence than was observed across much of the 2007 excavation, suggesting variation along the Ribbon in this respect;
- The surface showed a significant incline from east to west, perhaps reflecting a similar pattern of undulation to that observed along the Ribbon in 2007;
- The surface was located in a shallow cut in the base of the hollow such that it was an integral part of the base of the hollow;
- As in 2007, the surface did not completely occupy the base of the hollow, and this somewhat curious and potentially important detail does need to be recognised and accommodated within any given explanatory model;
- The broad cut/hollow in which the surface is located was of similar character and form to that observed in 2007. At this analytical stage, it appears that the observed morphology and profile of the hollow could equally be the product of cultural or natural processes (or the interaction of one with the other), and no direct evidence was recovered which can definitively determine the origin of this feature;
- The hollow in which the surface sits is a ‘stand-alone’ feature in its immediate context (i.e. the deep trenching in Trench 3 produced no evidence of a more extensive/more deeply buried palaeochannel complex/valley feature of earlier origin with which the Ribbon hollow might be associated);
- As judged from the *prima-facie* stratigraphic evidence, the formation of the surface and the hollow (or at least the hollow in the form as associated with the surface) are likely to be closely contemporary events (otherwise it is hard to explain why there are no intervening colluvial/alluvial/soil deposits between the densely consolidated surface and the underling natural);
- The underlying superficial geology in the vicinity of the Ribbon consists of clay and gravel deposits. In the base of the Ribbon hollow, those deposits showed a marked

‘striped’ pattern which appear to be the product of peri-glacial cryoturbation processes;

- The natural horizon on which the stone surface lay extended beyond the Ribbon hollow into the adjacent areas of undisturbed superficial geology, and this evidence strongly indicates that there is no formative relationship between the Ribbon surface (localised within the hollow only) and the broader patterns within the underlying superficial geology;
- Other identified Ribbon research issues – including the nature of the apparent upper and lower surfacing locally observed in 2007, burning activities apparently associated with the Ribbon, and the presence/relationship to the Ribbon of adjoining pits containing burnt stone - were not additionally evidenced in Trench 3, and no additional observations can therefore be made regarding those issues.

Possible ‘Ribbon related’ features in Trenches 1, 2, 4 and 5

- In Trench 4 the observed channel and primary fill sequence clearly reflects alluvial processes, and the associated deposition of eroded stone/sediment material (including culturally derived bone and flint) generated by up-slope water erosion. This demonstrates that these processes are an important potential factor in this landscape zone, and may in some degree be relevant to the understanding of features in other trenches;
- It is also very relevant that the Trench 4 channel can be stratigraphically demonstrated to have formed in a Mesolithic/Neolithic context. This suggests that although the Trench 4 channel and the Trench 3 Ribbon sequences are very different in specific characteristics - notably the character of the unconsolidated mixed/water-lain gravel fills in Trench 4 and the uniform ‘metalled’ ribbon surface in Trench 3 –they may have originated in the same time frame, and were almost certainly closely adjacent inter-visible features in the same earlier prehistoric landscape;
- The flint assemblage from the stratigraphically early silt/soil deposit in Trench 4 is an important contextual reference point, not only because it stratigraphically fixes the formation of the principal Trench 4 channel complex which cuts the deposit, but because it also most likely indicates Mesolithic activity in this vicinity (albeit with the caveat that one imported flint from the assemblage appears more consistent with a Neolithic date, and that the assemblage probably represents a time limited/transient event in terms of the activity which generated it). In addition, the formation of the silt/soil deposit which contained the assemblage, apparently within a shallow earlier hollow/channel feature, may be indicative of an earlier episode of (natural?) channel formation at this location;
- The particular stratigraphic/archaeological sequence in Trench 5 offers another important contextual reference point. The sequence is sealed by a an apparent burnt

mound which can be generically related to similar burnt mound-like features known from the adjoining Rotherwas Futures site and at three other sites across the South Hereford locality. Beneath the burnt mound, a lower stone surface set into the base of the hollow is likely to be of directly cultural origin (see, for example, the apparently artificial cut into the eastern side of the hollow), resembles the Ribbon in significant details, and is probably of broadly earlier prehistoric date given its stratigraphic situation. Two other surfaces (including one sealing a pit group overlooking the hollow) also seem to be of probable cultural origin (especially given the relationship to the burnt mound). How the Trench 5 deposits directly relate to the Trench 3/2007 excavation Ribbon feature (if at all) is unknown – they may yet be better understood as an extension of the adjoining Futures site sequence - but they do demonstrate that distinctive patterns of cultural practice, including the use and laying of stone surfaces in and around hollows, was a significant component of earlier prehistoric activity right across this part of the landscape;

- It may also be relevant to add that the surface of the superficial geology within Trench 5 exhibited peri-glacial effects, with alternate north-south aligned banded exposures of gravels and clays (similar to the peri-glacial striping effects in Trench 3), and probable cold related shattering of some of the natural gravel exposures. Interestingly, and perhaps significantly, there did appear to be spatial integration of the secondary stone surfaces within the pattern of the natural gravels and clays, perhaps suggesting the possibility that the natural gravel (and clay?) exposures were also being recognised and exploited as surfaces with cultural value;
- Additional narrow stone surfaces were located directly over the natural in the base of hollows in Trenches 1 and 2. These formed stratigraphically early elements of their respective sequences, and are undated (although they were both sealed by Roman associated contexts). The broad composition and character of the densely packed surface in Trench 1 in particular (with quartz, burnt stone and associated bone) did resemble the Ribbon (Trench 3 and 2007), while the sandstone dominated surface in Trench 2 produced a number of flints, but no other finds. Until these surfaces are more firmly dated their significance is hard to assess, and their stratigraphic position immediately beneath Roman pottery associated contexts naturally raises the possibility that they are also belong in that time-frame;
- As in Trench 3, it is very hard to certainly define, on the basis of clear evidence, the precise origin of the observed hollows/channels in Trenches 1,2, 4 and 5 with respect to the relative interplay of natural and cultural processes in their creation (and, despite superficial morphological similarities, particular hollows across the five trenches may have significantly different origins in this respect). However, the observation that the principal hollow in Trench 5 did seem to reflect a natural undulation in the underling superficial geology may well be relevant to that wider question.

Late Prehistoric, Roman and Post-Roman features

- Trenches 1 and 2 both produced spatially related arrangements of ditches and stone surfaces which were associated with/or sealed contexts containing Roman pottery, and which are therefore of Roman or later date. The surfaces (and their related ditches) occupy hollows/cuts in a pattern which, at least superficially, resembles other elements of the wider archaeological sequence from the trenches as a whole. In the central area of Trench 1 an upper Roman pottery associated surface overlay a lower surface which sealed silts containing further Roman pottery. It may or may not prove to be chronologically significant that, in a superficially similar pattern in Trench 2, the Roman associated upper surface in Trench 2 closely overlay the flint associated lower sandstone surface (see above);
- In addition to the various ditches which spatially contiguous to the surfaces in Trenches 1 and 2, Trenches 3 and 4 (but not Trench 5) also both produced stratigraphically late north-south aligned ditch complexes (probably later prehistoric and later) on the eastern side of the respective hollows/channels in those trenches (although direct dating evidence was not recovered from any of the Trench 3 and 4 ditches). As has been noted, direct connection between any of the ditch sections observed across Trenches 1-4 and in the 2007 Ribbon excavation (or, for that matter, between the earlier hollows with which these ditches are associated) cannot be safely inferred, despite their apparent similarities. However, there does seem to be a consistent general pattern where the partly in-filled earlier hollow features are being fossilised/marked in the later landscape by linear ditches. Whether or not this reflects overall demarcation of an inherited alignment, or whether it simply reflects, for example, more localised field drainage/boundary creation along convenient existing landscape features, cannot be certainly assessed from present evidence;
- Dark fill deposits including a dump of large stones and a significant assemblage of abraded Roman pottery and bone formed the upper element of the sequence within the hollow at the eastern end of Trench 1 (overlying the undated Ribbon like surface at the base of that hollow), and would seem to represent filling and levelling of this area in a Roman or later context. The character of these upper deposits (with the rubble most probably representing building demolition) is consistent with the presence a Roman (and possibly later?) settlement in the vicinity of Trench 1. A logical suggestion would be that Trench 1 is located on the northern edge of a main focus of settlement activity which lies immediately south of the trench (and it is worth noting that it is unlikely that the stone building debris was moved very far from the site of the structure it derives from);
- The presence of a spring 50 metres to the south-west of the Trench 1 (at the base of the steep northern slope of Dinedor Hill) may also be a significant feature with respect to a settlement focus in this area (and, indeed, to earlier settlement activity in this immediate landscape);
- Taking into account the structural character of the Roman pottery associated stone surfaces in Trenches 1 and 2 with their accompanying ditches, and in the light of the probable spatial relationship to a significant Roman settlement, a logical interpretation

of these features would be that they represent a sequence of paths/trackways heading up slope on a north-south alignment. That alignment and pattern, may of course, be significantly influenced by inherited settlement patterns and the micro-topography of the pre-existing landform;

- The character and nature of the settlement cannot be certainly inferred on present incidental evidence, although further analysis of the pottery, artefact and bone assemblage from Trench 1 in particular may potentially allow some further deductions in this respect. The broad chronological range of the Trench 1 pottery (from the first to the fourth centuries, see Roman pottery assessment below) does in itself tend to imply that this is a significant settlement with a complex history. The presence of stone buildings reinforces that impression, and it may be relevant to add that a nearby stone structure of probable Roman date (function uncertain) was also found in 2008 in excavations on the Rotherwas Futures site (700 metres to the north-east);
- The presence of significant Roman/later settlement activity in this area does have obvious implications for potential Roman/later disturbance and destruction of earlier cultural features which may once have existed in the same vicinity;
- Although the discovery of a Roman settlement was unexpected in the research context of the present project, the presence of ditches with Roman pottery found during the Access Road investigation (including the one which cut and ‘followed’ the Ribbon) has long indicated that there must be significant Roman period activity in the vicinity (indeed, it was primarily with the expectation of possible discovery of Roman settlement features that further investigation commenced in 2007 in the area where the Rotherwas Ribbon was subsequently found). In that sense, the results from the southern field in particular do help to partly resolve one of the wider archaeological questions raised by the Access Road investigations, and perhaps also establish a late-prehistoric to Early Medieval settlement context which is directly relevant to the understanding of the later ditches throughout Trenches 1-4 and the 2007 excavations;
- The undated but intriguing east-west curvilinear ditch in Trench 3 is late in the stratigraphic sequence. Also taking into account its atypical character, it is tempting to suggest that this could be of Early Medieval date. That is a purely speculative suggestion, but it does raise the possibility that significant settlement activity continued in this vicinity into a Post-Roman context. Indeed, the clearance of the former settlement site may have occurred in an Early Medieval context, and whenever that occurs it must reflect a coordinated act of landscape re-modelling and re-planning.

Integration of the excavation results with the geophysics and Lidar survey evidence

Lidar

- The Lidar Digital Terrain Model for the locality (Bapty and Atkinson 2011) produced no tangible pre-excavation evidence of any distinct topographical feature along the Ribbon corridor which could be distinguished from a wider pattern of subtle north-

south aligned hollows/ridges extending throughout this vicinity (whose significance is unclear, but which may be artefact of later agriculture and associated colluvial accumulation).

- Reviewing the DTM in the light of the Trench 1-5 excavated evidence essentially confirms that finding. There is no relationship between the surface topography and the buried features now known in those areas, and even a major feature such as the Trench 4 channel cannot be certainly detected on the Lidar beyond the confines of the excavated trench. It does therefore seem that, by whatever process, later re-modelling of the surface landform has entirely masked the micro-topography of the prehistoric landscape. Although this is a negative finding, it is an important one in the sense that it means there is no useful evidence from the Lidar to underpin further understanding of the spatial relationship between the features in each trench.

Geophysics

- The relationship of the geophysics data to the excavated evidence is complex (see Appendix 2 for trench by trench summary assessment). On the one hand, the general trend of the geophysics responses, and the broad incidence of cultural/natural features along the north-south linear alignment apparently indicated by the resistivity results in particular, does appear to be borne out by the trench by trench excavation results. However, in specific terms the relationship is less clear. To take Trench 1 as an example, the significant excavated features at the eastern end of the trench - including the hollow, the Roman rubble and fill deposits, and the well defined lower surface and its accompanying ditch - were not in any way indicated by the resistivity responses. In fact, the eastern end of this trench (and of Trench 2) was actually located/opened to test the broad 'band of higher conductivity' which was identified in the southern field. In reality, no apparent archaeological, geological or geomorphological feature could be identified in either Trench 1 or 2 which explained or correlated with this result. Elsewhere, even coherent and well defined features which lay relatively late in the stratigraphic sequence – notably the linear ditches – cannot be tangibly tracked or recognised within the geophysics responses;
- The other obvious complexity is that, even within the generally valid geophysical identification of a north-south zone of archaeological interest, there is very considerable variation in the specific excavated character and chronology of the features on that alignment. To the south, it does now seem likely that the broad spread of responses are mostly indicating the Roman/later settlement. However, at least in overview, there is no obvious analytical difference between, for example, the geophysics responses in that area, the responses which were associated with the probable palaeochannel in Trench 4, or the responses which were associated with the Bronze Age features in Trench 5. It may be that closer re-analysis of the data might tease out some distinctions, but there has to be a real question mark over the potential predictive power of that process given what we now know of the complexities (and uncertain inter-relationships) of the deposits and features along this corridor.

4. SPECIALIST REPORTS

4.1 Prehistoric Pottery (Emily Edwards)

A total of 15 sherds of late Bronze Age pottery were recovered from three contexts in Trench 5 at Rotherwas, the majority having been recovered from context 4505. These sherds were small, plain and abraded body sherds; all with the exception of one sherd were manufactured from quartzite fabrics matching either 5.4 or 5.8 in the Worcestershire Fabric series.

FEATURE	CONTEXT	SOIL SAMPLE	COUNT	WEIGHT	FABRIC	DATE
Soil Patch	4505	600	1	6	Quartzite	LBA
Soil Patch	4505	604	3	12	Quartzite	LBA
Soil Patch	4505	605	4	4	Quartzite	LBA
Soil Patch	4505	606	2	4	Quartzite	LBA
Soil Patch	4505	607	1	8	Quartzite	LBA
Soil Patch	4505	608	1	10	Quartzite	LBA
Natural Gravel	4510	609	1	0.5	Quartzite	LBA
Natural Gravel	4510	613	1	0.5	Grog	LBA?
Fill of Pit 4529	4530	624	1	4	Quartzite	LBA
			15	49		

Table 1: Table giving breakdown and quantification of prehistoric pottery (LBA: late Bronze Age)

Methodology

The entire assemblage was quantified by count and weight, with a note being made of principal fabric groups, forms, decoration and surface treatment. Spot dates were based on assessment of fabric, firing, decoration and form, fabric being determined through macroscopic examination. Fabric Codes are those recommended by the Prehistoric Ceramics Research Group (PCRG 1997).

Dating and Provenance

The majority of these sherds were recovered from contexts relating to a burnt mound, largely from deposit 4505, which is a spread rather than a secure context. The grog tempered sherd derives, however, from a more secure and discreet context: a pit that has been cut into the mound.

Generally speaking, in excess of 20 sherds or several diagnostic sherds are required from a single prehistoric context (Shennan 1981; De Roche 1977; Lambrick 1984) to allow some precision of dating taking into account residuality. This must be taken into account with the spot dating especially where there are less than five sherds.

Condition

These sherds were small, plain and abraded body sherds, which have an appearance consistent with having been middened before deposition, rather than having been broken for deposition or left in context.

Discussion

The significance of this group lies in the associated features, which are either directly interpreted as burnt mound deposits or are stratigraphically related to these. These sherds require further fabric analysis and comparisons with the Worcestershire fabric series, but very little additional work beyond a search for local and regional parallels, which will put the pottery into a regional context.

Additional Note (I Bapty)

It should be noted that two small pieces of prehistoric pottery from Trench 3 (associated with the stone surface) were mistakenly omitted from the report. These are not specifically diagnostic beyond a generic prehistoric date, but they will be additionally assessed at the Post Excavation stage.

4.2 Roman Pottery (C Jane Evans)

Introduction

One box of pottery was rapidly scanned to provide a summary and provisional dating, and an estimate of costs for post-excavation analysis. None of the pottery was marked. This proved to be a problem as some sherds were found loose at the bottom of the box, presumably having fallen out of one of the bags. These have been re-bagged as unstratified.

Fieldwork at Rotherwas produced c295 sherds of Roman pottery, most of which were fragmentary and abraded. Sufficient diagnostic sherds were present to date the sequence, although the small size of individual context assemblages meant that most could not be closely dated. The pottery came from 23 contexts, of which 12 produced 3 or fewer sherds.

Trench 1

The largest assemblages came from Trench 1 (Table 1), positioned to investigate the proposed line of the ribbon. These came from a ditch fill at the west end of the trench (fill 2505), a ditch fill from the east end of the trench (fill 2503) and layer of compact stone (2529).

The bulk of the assemblage comprised a range of Severn Valley ware fabrics, mainly oxidised, though other sources was also represented, including Black-burnished ware (BB1) from Dorset, Oxfordshire ware and 2 sherds of imported samian.

The pottery fabrics and forms indicated long date range for the sequence of deposits. The presence of Palaeozoic limestone tempered ware in particular suggested earliest Roman activity, dating up to perhaps c AD 60, while sherds in organic tempered Severn Valley ware indicated broadly 1st to 2nd century activity. Assemblages dated on this basis to the 1st century came from: stone layers 2529, and 2528 (same as 2532, the lowest fill of cut 2518), the latter associated with fire cracked stones; the lowest fill of ditch 2526 (2527); and 2524, the primary fill of cut 2523.

A few contexts produced BB1, suggesting a date after c AD 120. The band of stone (2503) within ditch 2530 included a fragmentary BB1 rim, probably dating to the later 2nd or 3rd century AD, as well as some residual 1st century material. This assemblage also included a distinctive, highly micaceous grey ware, and one of the two sherds of samian from the site. Fill 2508 produced a BB1 jar sherd decorated with right-angle cross-hatch, also suggesting a later 2nd to mid 3rd century date. The pottery from ditch fill 2504 was less diagnostic: only 6 sherds of Severn Valley ware were recovered with a broadly 1st to 2nd century date.

The latest Roman forms came from the largest assemblage, from upper ditch fill 2505. The 33 sherds of BB1 from this fill included a drop-flange bowl, along with a local copy of this form, and a sherd from a jar decorated with obtuse cross-hatch burnish. These suggest a late 3rd to mid 4th century date. This fill also produced the only sherd of Oxfordshire white mortaria and second sherd of samian from the site, presumably residual.

Small quantities of other finds were incorporated with the Roman pottery from Trench 1. A few fragments of ceramic building material, including imbrex roof tile, came from deposits 2503, 2511 and 2514. 2513 produced a broken fragment of burnt flint.

Trench 2

Trench 2 produced a much smaller assemblage, most of which came from cut 3001 (fills 3014 and 3002) and a layer of colluvium (3003). The dating for this material was limited. Colluvial layer 3003 included a sherd of BB1, which suggested a *tpq* of c AD 120. The Severn Valley ware forms from cut 3001 were not closely datable.

Trench 3

The box of Roman pottery included a small quantity of material from Trench 3. Fragments of burnt clay came from 3505, and very small fragments of abraded fired clay/pottery from 3514. The fill of a modern drainage ditch (3509, fill 3508) produced 2 sherds of post-medieval orange ware (WSM fabric 90) dating to the 18th century.

Trench 4

Trench 4 produced the smallest assemblage of Roman pottery, all in Severn Valley ware. The only identifiable form came from context 4003 (<502>) but this was not closely datable.

Trench 5

Also included amongst the Roman pottery were 12 sherds of earlier prehistoric pottery, mainly in an angular quartz tempered fabric (WSM Fabrics 5.4 and 5.8). These have been assessed by Emily Edwards.

Context	Sherd count
2503	63
2504	6
2505	105
2506	10
2508	2
2511	2
2513	1
2514	1
2515	1
2518	1
2522	2
2524	1
2525	1
2527	6
2528	3
2529	30
<i>Total Trench 1</i>	<i>235</i>
3002	11
3003	9
3006	1
3014	9
<i>Total Trench 2</i>	<i>30</i>
3514	2?
<i>Total Trench 3</i>	<i>2?</i>
4003	8
4004	14
<i>Total Trench 4</i>	<i>22</i>
<i>Total unstratified</i>	<i>8</i>
Total pot	297

Table 2: *Summary of the Roman pottery by Trench/context (sherd count)*

Suggestions for future work

Only the Roman pottery from Trench 1 justifies further analysis. The pottery provides a chronological sequence for the deposits investigated. More detailed analysis of the fabrics, specifically the Severn Valley ware, will allow for comparison with other Herefordshire sites, in particular the other sites excavated along the Rotherwas Ribbon (WHEAS 2009, 2010). It is estimated that c 15 sherds will require drawing, to illustrate the dating evidence.

4.3 Struck Lithics (Hugo Lamdyn-Whymark)

Introduction

One hundred and six flints were recovered from Excavation Trenches 1-5 that were excavated to investigate the course of the Rotherwas Ribbon to the north-west and south-east of the Rotherwas Access Road (Appendix 6). This report characterises the lithic assemblage and presents recommendations for future work.

Methodology

The flints were catalogued according to broad artefact/debitage type and retouched pieces were classified following standard morphological descriptions (Bamford 1985, 72-77; Healy 1988, 48-49; Bradley 1999, 211-227; Butler 2005). Additional information was recorded on the condition of the artefacts, including burning, breakage, the degree of edge-damage and the degree of cortication. The assemblage was catalogued directly onto a Microsoft Access database and data was manipulated in Microsoft Excel.

Raw material and condition

The struck lithics are all manufactured from flint, but variations in texture, colour and cortex indicate that the flint raw materials were obtained from at least three different sources. The most common raw material was a light yellowish brown to mid brown flint that exhibits an abraded and slightly pitted surface. The colour and an abraded surface indicate that this raw material was obtained from a secondary source, such as river gravels. A second raw material, represented by only five flakes from contexts 2512, 4002 (3 flakes) and 4505, is a dark brown flint with a 2-3 mm thick cortex. The cortex was typically buff coloured, but in one example it was white (4002). This raw material may originate from a chalk region. The third flint raw material, Bullhead Bed flint from the base of the Reading Beds, is represented by a single flint flake from context 4002 (SF 538). The flake exhibits a 2 mm thick dark olive green cortex and an underlying 3 mm thick mid orange band; the flint is mid brown with occasional whitish-grey inclusions (Figure 1). The closest outcrop of Reading Beds is located to the south of Marlborough, Wiltshire, 105 km to the south-east of the excavation. The main deposits of Bullhead Bed flint are located further east around the edge of the London Syncline, with extensive

outcrops around Newbury, Reading, Essex, the North Downs and north Kent (Sumbler 1996).

The flint assemblage was in variable condition, but individual contexts typically yielded artefacts of comparable condition. The flints from Trenches 1 and 2 exhibited moderate edge-damage indicating that these artefacts have been subject to some post-depositional disturbance. The flints from Trenches 3, 4 and 5 generally exhibited only slight edge-damage, and a few flints from context 4002 were in fresh condition, raising the possibility that artefacts from these trenches were recovered from broadly contemporary contexts. Three flints from context 4002 and one flint from 4506, however, exhibit moderate edge-damage indicating that at least some flints were exposed for a period before burial.

The greater part of the assemblage was free from surface cortication, but approximately half of the flints from context 4002 and occasional flints from other contexts exhibited a light white or bluish-white cortication. One flint from context 3545 exhibited a moderate white surface cortication. The degree of cortication reflects localised ground conditions and cannot be used as evidence for dating.

The assemblage

The flint assemblage will be considered by Trench below.

Trench 1

Trench 1 yielded two flint flakes and an end scraper with a spur on its right hand side. The scraper was recovered from the lower metallated surface (2511) and the flakes were recovered from overlying layers (2514 and 2515), which are located between the lower and upper surfaces. All three flints exhibit moderate edge-damage. This condition is typical of material exposed to trampling and disturbance in surface layers. These flints are not particularly diagnostic, but they are likely to date from the Neolithic or Bronze Age.

Trench 2

Trench 2 yielded two flint flakes of squat proportions (colluvium 3005 and the fill of feature 3001, 3014) and a burnt and broken end scraper of thumbnail proportions (subsoil 3002). These flint all exhibited moderate edge-damage. The flints are not intrinsically datable, but these artefacts would not be out of place in a late Neolithic/early Bronze Age assemblage.

Trench 3

Eleven flints, comprising eight flakes, a piercer, a thumbnail scraper and a knife were recovered from Trench 3. The flakes are all of comparatively squat proportions, but few technological attributes can be observed as five flakes are broken and one is burnt. The

retouched tools comprise a piercer manufactured by enhancing a point on a broken flake (colluvium 3513), a D-shaped thumbnail scraper exhibiting fine pressure-flaked retouch (colluvium 3513) and the distal end of a knife (ditch 3512, fill 3510). The knife exhibits pressure-flaked semi-abrupt retouch along the left hand side and slight abrupt retouch along the right hand side and around the distal end. The distal end exhibits a small area of crushing and wear that may result from use as a strike-a-light. The style of retouch on the knife and scraper and the form of these tools is typical of the late Neolithic/early Bronze Age. The other artefacts are not intrinsically datable, but they may be broadly contemporary with the tools.

Trench 4

Trench 4 yielded the largest assemblage with 79 flints. Sixty-nine flints were recovered from a flint scatter in colluvium (4002) and a further seven flints were recovered from the overlying interface between the colluvium and alluvium (4003). A flake (layer 4011) and a chip (4006) were recovered from the fills of palaeochannel 4027 and a petit tranchet/chisel arrowhead (SF 588) was recovered as a residual find in ditch 4019, fill 4024. One corner of the arrowhead's blade edge is broken and base of the arrowhead is snapped, however, the latter appears to have occurred during manufacture as a small area of retouch extends on to the broken edge. The broken corner reveals that this artefact has been lightly burnt. This form of arrowhead dates from the middle Neolithic and the style is commonly associated with Peterborough Ware.

The flint scatter in colluvium 4002 and the overlying layer 4003 is dominated by thin chips (flakes with a maximum dimension less than 10 mm) and small flakes; the largest flake recovered from these contexts measures 30 mm in length. Only one blade and two flakes of blade-like proportions are present and only two flakes exhibit platform-edge abrasion. This indicates that small flakes were the intended product. A single platform core on a flake and a tested nodule, weighing 13 g and 10 g respectively, support this view as the flake scars on their surface measure between 10 mm and 15 mm in length. No refits were found between the cores and the flakes and it is clear that several flakes originate from different cores. Therefore, while the cores may indicate some flint knapping, the scatter may also contain utilised flakes from other knapping events.

One flake is particularly notable as it manufactured from a distinct raw material, Bullhead Bed flint, and it has been deliberately snapped at both ends to form a wedge-shaped flake segment (SF 538, Figure 1) (Lamdin-Whymark forthcoming). The resemblance of this artefact to a chisel arrowhead is striking, but the tool cannot be classified as an arrowhead due to the absence of formal retouch. The front edge of this flake exhibits extensive use-wear. It is likely that this flint was imported to the site as a finished tool, which was subsequently lost or discarded, as no comparable flints are present in the assemblage and the raw material is available at a minimum of 105 km to the south west. It is also notable that three (of five) potentially chalk flint flakes were recovered from colluvium 4002, as these also potentially indicate long distance links with chalk regions to the south-east.

The only retouched tool in the scatter is a small fragment of the edge of a retouched flake. However, an 18 mm burin spall struck from the distal end of a flake and a distal micro-burin indicates the manufacture and presence of a burin and microlith.

Dating this flint scatter is problematic as the burin spall and the micro-burin date from the Mesolithic, but the associated flake technology is not typical of this period. It is possible that the smaller flakes represent an expedient Mesolithic industry designed to produce flakes for a specific task, but *c* 6 of the larger flakes are comparable to the later Neolithic/early Bronze Age flake debitage recovered elsewhere on site. Moreover, the wedge-shaped flake is manufactured from Bullhead Bed flint that is most commonly used in the later Neolithic. Therefore while the majority of these flints are probably Mesolithic, the date of a small number of these artefacts must remain open until the deposit can be scientifically dated.

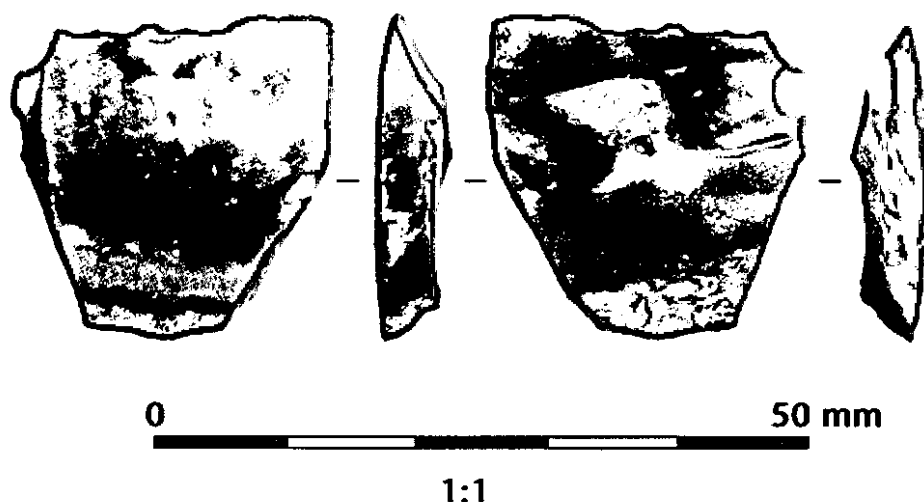

Plate 26: *Wedge-shaped flake segment of Bullhead Bed flint from layer 4002, SF 538. The closest source of this material is 105 km from the site to the south of Marlborough, Wiltshire. Note the fine fracture lines on both breaks indicating fracture by flexion*

Trench 5

Ten flints comprising eight flakes, a piece of irregular waste and a piercer was recovered from Trench 5. The flakes are of broad proportion and were struck from cores orientated towards flake production, without preparation of the core edge. The flakes from this trench are comparatively large for the site and the largest is 34 mm long. Two flakes exhibit extensive use-wear. The piercer, recovered from the surface of the natural gravel (4510=4523), was manufactured on a broken flake and exhibits a small sharp point. These artefacts are most characteristic of the late Neolithic/early Bronze Age.

Potential

Trenches 1 to 5 have recovered a comparatively substantial assemblage of 106 flint artefacts that complement assemblages from the Hereford Bypass Excavations (209 flints) and fieldwalking in Field 11 (111 flints). The flint scatter in Trench 4 contains two Mesolithic artefacts and although dating is problematic, the majority if not all of the assemblage may date from this period. The Bypass Excavations yielded a single Mesolithic flint and a core-rejuvenation tablet from Field 11 is also likely to be of an early date. Recent excavations at Rotherwas Futures also recovered a small assemblage of Mesolithic flintwork. The Mesolithic flints from this excavation therefore add to a growing corpus of early activity in this landscape, although they have not potential for further analytical investigation.

The wedge-shaped flake of Bullhead Bed flint and three flint flakes potentially of chalk flint from 4002, along with two further possible chalk flint flakes from contexts 2512 and 4505, indicate contact with distant regions to the south-east. However, considering the uncertainty over the date of scatter 4002, it is not clear if these artefacts reflect long distant contacts in the Mesolithic or later periods.

The petit tranchet arrowhead in Trench 4, Ditch 4019 can be paralleled with an example from the Bypass Excavations, Ditch 1479 which cut the burnt stone surface. These arrowheads date from the middle Neolithic and add to a small number of artefacts that indicate Neolithic activity in the landscape prior to the construction of the Rotherwas Ribbón. Other evidence includes a fragmentary early Neolithic leaf-shaped arrowhead from the Bypass Excavations and a possibly early Neolithic assemblage from Rotherwas Futures.

The remaining 29 flints from the excavations include a knife and two thumbnail scrapers dating from the late Neolithic/early Bronze Age and it likely that the other flake debitage is broadly contemporary. Thumbnail scrapers and knives were a common feature of the Bypass assemblage and the technological attributes of these artefacts should be analysed and considered alongside these.

Recommendations

A publication text of *c* 2000 words with 1-2 tables should be prepared using the assessment text as the basis of the document, but expanding the discussion to include other sites in the region. The scrapers from this excavation should be included in the scraper analysis proposed for those from the Bypass Excavation as the combined assemblage is not paralleled in the region.

A metrical and technological attribute analysis is not recommended as it will not clarify the date of the flints from context 4002. Similarly, a refitting exercise on the flint from 4002 is not recommended as it is unlikely to be successful and it will not further elucidate reduction techniques.

The illustration of seven retouched tools will complement the report and minimise the need for descriptive text. A provisional list comprises all three scrapers, the petit tranchet arrowhead, the wedge-shaped flake, the backed knife and a piercer.

4.4 Animal Bone (Ian Baxter)

Background

Recovery

The bones forming this assessment were collected by hand.

Residuality and contamination

No information regarding residuality or contamination is available to the author at this time.

Context

The animal bones are mostly derived from ditches and pits.

Preservation

The preservation of the bone ranges from fair to poor with many comminuted fragments.

Storage and quantity

The hand collected animal bones are stored in 1 cardboard box of the following size: 47x28x21cm. The bones are washed and bagged by context.

A total of 377 fragments of animal bones were recovered from the site with a total weight of 4Kg.

Assessment

Methods

All identifiable animal bones have been catalogued in trench and context order.

Variety

The assemblage is exclusively composed of the remains of domestic mammals, with cattle (*Bos*), sheep/goat (*Ovis/Capra*), pig (*Sus*) and horse (*Equus*) all represented. The material recovered from Trench 1 is in a much better state of preservation than that recovered from the other trenches and comprises 83% of identifiable animal bone. These

remains are thought to date from the Romano-British period. The only other identifiable animal bone fragments were recovered from Trenches 3 and 4 and are thought to date from the Neolithic/Early Bronze Age. This material is poorly preserved and consists of tooth fragments from cattle and sheep/goat together with much eroded cattle long bone shaft fragments.

Potential and recommendations

Potential

The assemblage is too small and too poorly preserved to warrant further study.

Recommendations

As all the identifiable animal bone fragments are listed in the catalogue forming part of this report it is recommended that no further analysis is required.

Context	Taxon	Skeletal Element	Comments
Trench 1			
2503	<i>Bos</i>	lt. lower P4 sacrum phalanx I	
	<i>Sus</i>	proximal radius	
2505	<i>Bos</i>	frontal fragment 2x proximal femur fragments 2x proximal metacarpus fragments proximal metatarsus fragment phalanx I 2x phalanx II 2x phalanx III	lt. & rt.
2506	<i>Bos</i>	anterior mandible fragment	rt.
2511	<i>Equus</i> <i>Bos</i>	proximal radius + ulna shaft lower M1 scapula fragments distal humerus shaft fragment proximal ulna fragment 2x tibia shaft fragments	
	<i>Ovis/Capra</i>		
2513	<i>Sus</i>	upper M2 fragment	
2514	<i>Bos</i> <i>Ovis/Capra</i> <i>Sus</i>	proximal ulna fragment upper M3 upper M2	lt.
2515	<i>Sus</i>	premolar fragment	

2517	<i>Bos</i> <i>Ovis/Capra</i>	proximal ulna fragment lower M2 distal humerus shaft fragment	
2518	<i>Equus</i> <i>Bos</i>	axis fragment distal femur fragment	
2524	<i>Bos</i>	distal metatarsus	
2525	<i>Bos</i> <i>Sus</i>	upper M2 upper M3 lower M3	} probably adjacent } teeth
2529	<i>Bos</i> <i>Ovis/Capra</i>	distal humerus shaft fragment proximal femur shaft fragment	
2531	<i>Bos</i>	proximal femur fragment proximal metatarsus fragment	
2532	<i>Bos</i>	proximal ulna fragment	
2533	<i>Ovis/Capra</i>	tibia shaft fragment	
Trench 2			
3016	<i>Bos</i>	lower M3 fragments	
Trench 3			
3513	<i>Bos</i>	upper M3	SF418
3514	<i>Bos</i> <i>Bos</i>	metatarsus shaft fragment metatarsus shaft fragment	SF415 SF417
3522	<i>Bos</i>	incisor	
3545	<i>Ovis/Capra</i>	upper molar fragment	
Trench 4			
4002	<i>Bos</i>	molar fragment molar fragment molar fragment	SF526 SF554 SF556

Table 3: Animal Bone Catalogue

4.5 Environmental Remains (Liz Pearson and Nick Daffern)

*It should be noted that the environmental tables are located in Appendix 7

Introduction and archaeological background

An analysis of environmental remains from an archaeological excavation at Rotherwas Ribbon, Rotherwas, Herefordshire (NGR SO 35050 23660) was undertaken on behalf Herefordshire Archaeology. Excavations conducted in 2007 (Sworn and Woodiwiss 2008) revealed an unusual feature interpreted as a Neolithic or Early Bronze Age linear structure consisting of a 6 to 8 metre wide stone surface located within a hollow or cut. The surface was associated with a significant bone, pottery and flint assemblage and appeared to be spatially and chronologically linked with other features in the vicinity, such as pits filled with burnt stone. The Ribbon was also cut by two probable late Iron Age to Roman ditches on broadly the same alignment. Further excavation in 2010 has resulted in samples being taken from 58 contexts of prehistoric to Roman date. A total of 33 contexts were selected for assessment.

Project parameters

The environmental project conforms to relevant sections of the Standard and guidance for archaeological excavation (IfA 2008) and Environmental Archaeology: a guide to the theory and practice of methods, from sampling and recovery to post-excavation (English Heritage 2002).

Aims and objectives

The relevant objectives for the palaeoenvironmental assessment are as follows:

- To further test the combined relationship, character and formation process of the Ribbon surface, intervening silt/other deposit horizons, and the Ribbon 'construction cut' (in so as these components are collectively present along the monument as a whole)
- To assess the relationship of the Rotherwas Ribbon to other archaeological features in its vicinity including associated pits, the known earlier ditch, and the later ditches, and to interrogate the reason for the coincidence of these features in one corridor
- To identify additional dating evidence for the construction/development phases of the Ribbon, particularly with respect to the recovery of dating material (C14, OSL and artefact) sealed by the Ribbon surfaces
- To undertake palaeoenvironmental sampling of secure/sealed archaeological contexts associated with the Ribbon, including potential recovery of pollen, plant macrofossil and charred plant remains

Methods

Fieldwork and sampling policy

The environmental sampling strategy conformed to standard Worcestershire Historic Environment and Archaeology Service (WHEAS) practice (CAS 1995, appendix 4). Large animal bone was hand-collected during excavation and is reported on separately (Section XX). However, animal bone recovered from sample residues is reported on here. A total of 58 contexts were sampled (Env Table 1) from the following types of context: Samples of up to 100 litres were taken from twelve compact stone layers (two to four contexts per trench) for the purpose of characterising the feature known as the Ribbon, using a combination of geoarchaeological and palaeoenvironmental techniques

- Three further samples (100 litres) were taken from layers directly above or below the compact stone layers for comparison
- Five samples were taken from a control, natural gravels or colluvium for geoarchaeological analysis
- Two columns of spit samples, taken in 5cm increments, were taken from a palaeochannel sequence in Trench 4
- Up to 40 litres were also taken from various other features such as ditches, pits, a burnt mound and other stony surfaces not conclusively identified as Ribbon surface
- The above were logged, and the contents recorded, separately by individual buckets to allow variability to be determined, particularly across each surface, at the full analysis stage.

As the resources were limited, in order to maximise the spread of contexts assessed across the site, sub-samples of 10 litres (and in some cases 20 litres) were processed and assessed from the following contexts:

- Seven of the 12 'Ribbon' contexts (contexts 2511, 2517 and 2532 from Trench 1; 3006 and 3017 from Trench 2 and 4028 and 4514 from Trench 5)
- Three contexts directly above or below the 'Ribbon'; contexts 3513, 3546 and 4008
- Six spit samples (top, middle and bottom of two palaeochannel sequences) were assessed; contexts 4006, 4008, 4009, 4011, and 4037
- A total of 14 other contexts, including ditch, pit, burnt mound and charcoal layers were assessed

Processing and analysis

Macrofossil remains

For samples from waterlogged deposits (possible palaeochannel, Trench 4) a sub-sample of 1 litre was processed by the wash-over technique as follows. The sub-sample was broken up in a bowl of water to separate the light organic remains from the mineral fraction and heavier residue. The water, with the light organic fraction was decanted onto a

300µ sieve and the residue washed through a 1mm sieve. The remainder of the bulk sample was retained for further analysis.

For samples taken from the Ribbon, a proportion of the 100 litres (a sufficient volume to produce at least 250 clasts for analysis) was fractionated using a nest of sieves (Allen, this volume). The soil fraction was retained for tank flotation at a later date if needed. Results of the clast analysis are described separately below.

The samples were processed by flotation using a Siraf tank. The flots were collected on a 300µm sieve and the residue retained on a 1mm mesh. This allows for the recovery of items such as small animal bones, molluscs and seeds.

The residues were fully sorted by eye and the abundance of each category of environmental remains estimated. For selected contexts (Table 3) weights (g) were also recorded for each category of remains sorted from the residue in order to determine whether this method would be useful in analysing the component make-up of the ribbon surface(s). The flots were scanned using a low power MEIJI stereo light microscope and plant remains identified using modern reference collections maintained by the Service, and seed identification manual (Cappers et al 2006). Nomenclature for the plant remains follows the New Flora of the British Isles, 2nd edition (Stace 1997).

Charcoal

For samples containing fragments of charcoal over 4-5mm in size, selected fragments were fractured and examined using a low-power microscope to determine whether non-oak fragments were present. These were identified as having potential for radiocarbon dating or contributing towards palaeoenvironmental analyses.

Pollen

Six pollen samples of 2cm³ were selected for assessment, two were "grab samples" taken from the Ribbon deposit in Trench 5 (Mike Allen pers comm) whilst the remaining four (two per monolith, top and bottom) were taken from monoliths <176> and <190> which sampled the fills of palaeochannels [4027] and [4033] in Trench 4; the exact depths are given in the results section below.

The samples were submitted to the laboratories of the Department of Geography and Environment at the University of Aberdeen for chemical preparation following standard procedures as described by Barber (1976) and Moore et al (1991). The full methodology is described in Appendix 1.

Where preservation allowed, pollen grains were counted to a total of 150 land pollen grains (TLP) for assessment purposes using a GS binocular polarising microscope at x400 magnification. Identification was aided by using the pollen reference slide collection maintained by the Service, and the pollen reference manual by Moore et al (1991). Nomenclature for pollen follows Stace (2010) and Bennett (1994).

Fungal spores and parasite ova were noted with rapid identification being undertaken to genus level. Identifications were aided through reference material maintained by the Service and reference manuals Kirk et al (2008) and Grant-Smith (2000).

Macrofossil remains (Elizabeth Pearson)

The environmental evidence recovered is summarised in Tables 2 to 4. Uncharred plant material was ubiquitous in these samples but is assumed to be modern; as the condition was relatively fresh, it is probably a result of contamination at the time of excavation. This consisted mostly of cereal straw fragments and unidentified herbaceous material (presumably finely fragmented straw) which is likely to derive from the cereal stubble present on the site at the time of excavation. Uncharred weed seeds such as chickweed (*Stellaria media*), fat hen (*Chenopodium album*) and knotweed (*Polygonum aviculare*) are likely to have been associated with the cereal crop. This material, as it is not considered to be contemporary with the archaeological deposits, is not discussed below and only the results of samples containing charred plant remains are tabulated (Env Table 4). Charcoal was generally too fragmented to be identifiable unless otherwise stated. Some detail is given on artefactual material recovered from residues as this complements the hand-collected material and the recording allows more accurate comparison of the proportion of these components in each deposit.

Remains from Trenches 1 and 2 are associated with Romano-British activity, while material recorded from Trenches 3, 4 and 5 is undated, but other artefactual material is of prehistoric origin based on preliminary dating evidence (is this too generalised?). The results below are based on a combination of results based on weight (g) of each component identified, and where not available, an estimate of abundance.

Trench 1

Environmental remains were generally poorly preserved in these samples, all of which derived from deposits of Romano-British date, but there were slight differences in the proportions of material recorded. A sample from the lower compact stone layer (2517) contained small quantities of fragmented animal bone and charcoal in association with occasional pottery sherds but a relatively large proportion of ceramic building material (probably tile). An overlying stone layer (2511) was made up of similar material with the exception of the tile. To the east in a sample from a metalled surface (2532), animal bone was slightly more prominent (a pig mandible with molar being noted) along with a single poorly preserved charred grass grain (*Poaceae* sp indet), occasional mollusc remains, fragmented charcoal, and iron slag or concretions (Tables 2 and 3). The pottery recovered included Roman Severn Valley ware (2517) and Iron Age to early Roman Malvernian ware in 2511 (Jane Evans pers comm).

Trench 2

Low levels of fragmented animal bone, charcoal, pottery sherds and coal were identified from stone layers 3006 and 3017. Similar material was identified from ditch 3016 and the

only environmental remains identifiable to species were a single charred emmer or spelt wheat (*Triticum dicoccum/spelta*) grain from this ditch.

Trench 3

Charcoal was slightly more abundant in stone layer 3545 than in Trenches 1 and 2, and included potentially identifiable fragments. Deposits overlying the ribbon (3513) and ditch fills (3517, 3524 and 3538) were relatively charcoal-rich compared to samples from previous trenches, and particularly the upper fill of a large semi-circular ditch (3538) which included some non-oak fragments. Occasional charred grains of possible emmer wheat (*Triticum cf dicoccum*), unidentified wheat (*Triticum sp*) and hulled barley (*Hordeum vulgare*) were also identified in this ditch.

Cracked stone was generally more abundant in this trench and Trench 5 (below). Occasional fragments of flint and quartz were also recorded.

Trench 4

Only low levels of finely fragmented charcoal were identified in samples from a palaeochannel of unknown date; a basal gravelly fill (4011), overlying silty clay (4009) and fills of a later cut (4037, 4006 and 4008). Spit samples were assessed from the top, middle and bottom of the earlier fills and of the later cut. These results show these to be relatively inorganic, and hence little can be determined about the surrounding environment during the infilling of this channel from the macrofossil remains. Burnt stone was identified in the residue of a larger sample of the stony base of the later channel (4008), showing some evidence for human activity in the vicinity along with occasional fragments of flint and glass.

Remains from a stony layer (4028) were of a similar composition to those identified in Trenches 1, 2, 3 and 5, while only fragmented charcoal was identified in ditch fills 4019 and 4021. Context 4029 was interpreted as a natural deposit but contained relatively abundant finely fragmented charcoal, present in the flint, and some burnt stone.

Trench 5

Only occasional charcoal and iron concretions were identified from stony layer 4514. Charcoal was abundant in layer 4531, with some fragments being identifiable as non-oak. Nevertheless, charcoal was not particularly abundant in other deposits associated with burning such as 4505, a charcoal patch within the gravel and 4506, a burnt mound, although finely fragmented charcoal was present in a pit associated with the burnt mound (4535). Flint (potentially waste flakes) was recovered from contexts 4505 and 4507 and cracked stone (fire or frost-shattered?) was present in several contexts was particularly abundant in 4531.

Discussion

Bulk sampling of compact stone-rich layers, associated deposits (such as colluvial layers) and other features such as ditches and pits has shown some variation in composition of artefactual and ecofactual material from the southern upper slope to northern lower slope. The variation does not seem to be specific just to the stone-rich layers which make up the feature known as the Ribbon, but also associated colluvial layers and other features alongside. Animal bone was more abundant in compact stone layers in Trench 1 and Trench 2 by weight (Env Table 3) and is associated with Romano-British activity as Iron Age to Roman pottery was recovered from these layers, and other Roman features were identified in the trench. Charcoal (and to some extent low levels of charred cereal grain) was more abundant in Trench 3 and 5 deposits, with some potentially identifiable non-oak charcoal fragments surviving in compact stone layer 3545 and the upper fill of the large curvilinear ditch 3538. This would suggest more intense human activity in these areas which is in keeping with the concentration of archaeological features revealed during this excavation and previously to the north of Trench 3 during the Rotherwas Access Road excavations (Sworn and Woodiwiss 2009).

Small, rounded iron concretions were present in all trenches, but it is uncertain whether these represent natural material or weathered iron slag. The cracked stone shows no evidence of burning, and hence could be frost-shattered, but as it is more abundant in Trenches 3 and 5 where archaeological features and charcoal are more prevalent, heat-cracking seems more likely.

As each stone layer sampled is extensive there may be some variability between 10 litre sub-samples, but the assessment has provided a general impression of the non-clast component and a hint of variation in ecofactual and artefactual remains along the length of the site. The slight variations noted between trenches are also apparent from the records of hand-collected material, particularly the greater quantity of pottery and animal bone in Ribbon deposits on the upper slope (Trenches 1 and 2) and of flint, quartz and cracked stone on the mid to lower slope. Until more dating evidence is available it is uncertain whether the pits and ditches alongside the feature known as the Ribbon are contemporary with its proposed formation or use. The general impression from assessment of remains found in all samples suggest that if these features were contemporary with the stone layers charcoal, bone, and pottery, for example, could have spread across the area to the stone layers by trampling, although it cannot be ruled out that some of this could be intrusive. Larger items such as cracked stone and large fragments of bone are less likely to be intrusive and are more likely to be 'manuports' directly added to modify the stone layers, perhaps to make a surface. There may be some erosion of non-clast material down slope as whereas flint, quartz and glass are recorded from hand-collected material mainly from Trench 3, they appear in the samples as small occasional fragments downslope in Trenches 3 and 4.

Little interpretation can be made of environmental conditions during the silting up of the palaeochannel and hence these samples are of no value for reconstruction of the surrounding vegetation. The presence of charcoal may imply some human activity near

by, although it is possible that this could be intrusive from later deposits. Similarly, little detailed interpretation can be made of the function of the features alongside the compact stone surface, or aspects such as the arable economy from the small quantities of ecofactual remains recovered judging from the processing of 10 litre sub-samples.

Nevertheless, processing of the remainder of some of the samples may aid characterisation of the assemblages, comparison between compact stone layers/surfaces and other features, and assessment of taphonomic processes. In this case artefactual evidence is seen as being as relevant as ecofactual evidence, in order to provide a comprehensive breakdown of the non-clast component of samples. Further processing may also provide suitable material for radiocarbon dating if needed.

Pollen Analysis (Nick Daffern)

Results

The palynological evidence recovered is summarised in Table 5. No samples contained adequate polliniferous material to achieve a complete assessment count

Pollen

<176> 0.04m (4009) and 0.32m (4011)

Very limited quantities of herbaceous species were identified within both samples consisting of Poaceae indet (grasses) and *Urtica dioica* (stinging nettle) and solitary grains of Lactuceae undiff (chicory/dandelion/sow-thistle), *Cichorium intybus*-type (chicory/dandelion), *Ranunculus acris*-type (meadow buttercup), *Plantago lanceolata* (ribwort plantain) and Rosaceae (rose family). No grains of tree, shrub or heath species were encountered within the sample although the spores of Pteropsida (mono) indet (ferns) were rarely identified.

<190> 0.04m (4037)

Pollen preservation within this sample was again poor although the species diversity was higher than that exhibited in the previous sample. Herbaceous species again dominated with Poaceae indet the main contributor with rare identifications of Apiaceae (carrot family), Chenopodioideae (goosefoot subfamily), Lactuceae undiff, *Plantago lanceolata*, *Solidago virgaurea*-type (daisies/goldenrods) and *Urtica dioica*. Tree and shrub species were identified for the first time in the assessment with the presence of *Quercus* (oak), *Corylus avellana*-type (hazel) and *Salix* (willow).

The spores of Pteropsida (mono) indet and *Pteridium aquilinum* (bracken) were also present. The sole grain of an aquatic species was that of cf *Nuphar* (yellow water-lily) although due to detritus concealing the majority of the grain, with only the pronounced echinae available as a diagnostic feature, this identification must remain slightly tentative.

<190> 0.64m (4007)

Preservation and concentrations within this sample were superior to that encountered before although despite this, a complete assessment count could not be achieved. Herbaceous species and in particular, Poaceae indet, were again dominant although significant contributions were made by Lactuceae undiff, *Plantago lanceolata* and Cyperaceae undiff (sedges). Species diversity of herbaceous species was high with lesser contributions being made by, amongst others, *Ranunculus acris*-type, Rosaceae, Saxifragaceae (saxifrage family), *Solidago virgaurea*-type, *Filipendula* (meadowsweet), and Caryophyllaceae (pink family).

Trees and shrubs were also present in greater quantities and diversity with identifications of *Quercus*, *Alnus glutinosa* (alder), *Corylus avellana*-type and *Salix* being made. Spores of *Polypodium* (polypody) and *Pteridium aquilinum* were also present.

Ribbon – 0.02m

Preservation within this sample was poor with very low concentrations of pollen grains. Poaceae indet was again the dominant species with additional solitary herbaceous identifications of *Plantago lanceolata*, *Saxifraga granulata*-type (meadow saxifrage), *Urtica dioica* and Lactuceae undiff.

No shrub species were identified and only two solitary identifications of tree species, *Betula* (birch) and *Fraxinus excelsior* (ash), occurred.

A single spore of *Pteridium aquilinum* was also present.

Ribbon – 0.06m

Pollen preservation and concentration were much improved in this sample when compared to the previous Ribbon sample.

Herbaceous species again dominated with Poaceae indet the main contributor although species diversity was high amongst the remaining herbaceous identification with grains of *Plantago lanceolata*, *Urtica dioica*, *Achillea*-type (yarrows/chamomiles), Lactuceae undiff, Cyperaceae undiff, *Chrysosplenium* (golden saxifrage) and *Rumex acetosella* (sheep's sorrel), *Ranunculus acris*-type and *Solidago virgaurea*-type.

Of particular note are the presence of two *Cerealia* indet (indeterminate cereal) grains and a solitary grain of *Avena/Triticum* (oat/wheat) with the latter being particularly well preserved.

Quercus was the sole tree species identified from this sample and *Pteridium aquilinum* the sole spore producing species.

Parasite ova and fungal spores

The fungal spores of *Chaetomium* sp and *Cladosporium* sp were infrequently identified from the two samples from the Ribbon deposits in Trench 5. Both genera are ubiquitous within the atmosphere and soils although both are commonly found on plant debris with *Cladosporium* sp particularly prevalent upon dead herbaceous and woody plants. From the upper Ribbon sample (2cm) there were also tentative identifications of *Agrocybe* (field-cap) sp spore. This is a genus of saprobic (lives on decaying organic material) mushrooms which grow in grassland, woods and on dung. No parasite ova were identified during the assessment.

Discussion

Due to the exceedingly low pollen concentrations encountered and the tendency for preferential preservation, drawing any conclusions from the assessment would prove to be problematic yet brief comments will be made.

Despite the low concentrations, herbaceous species were dominant suggesting that the landscape surrounding the site throughout the time period in question, i.e. both that of the palaeochannels and the exposed compact stone surfaces, had been subject to some clearance although the extent and nature of this cannot be determined due to the incomplete counts. The diversity and types of herbaceous species identified was noteworthy considering the general scarcity of remains; tending to indicate that the landscape was open, healthy, short grassland, the presence of sheep's sorrel being particularly indicative of this, possibly indicating livestock grazing within close proximity.

There were indications of disturbed and less managed/grazed ground, evident in the form of stinging nettles, ferns, bracken. Wet/damp conditions presumably associated with the palaeochannel are evident in the form golden-saxifrage, sedges and meadowsweet. The source of the tree and shrub pollen is unclear as it may be originating from wooded areas peripheral to the grassland, on the summit of Dinedor Hill or alternatively it represents scrubby woodland flanking the channel margins. The latter seems less likely due to the limited contribution that was made by tree and shrub pollen; a higher figure would be expected if this were the case due to the fall of grains directly into the deposit and the considerable pollen production and robustness of grains produced by alder and oak.

The presence of cereal grains (0.06m) from the lower sample of Ribbon deposits was of great potential interest as these would have provided a rather broad terminus post quem for the compact stone surfaces, i.e. early Neolithic onwards, but also may have provided indications of the landscape both pre- and during any potential use of the stone layers. Unfortunately, it should be noted that the cereal grains were in an extremely good state of preservation which is greatly in contrast to the material from the other samples, the majority of which exhibited signs of mechanical damage and oxidisation, and this therefore raises the question of whether the grains are intrusive or contamination

associated with the excavation. The potential of this is quite high given that contamination has been noted in the plant macrofossil assessment and given that the site did contain arable stubble at the time of excavation (Pearson pers comm).

The presence of the field-cap and the Chaetomium sp and Cladosporium sp spores indicate that decaying organic material is present within the local environment. How this can be interpreted within the context of the stone layers is very open as it may merely indicate natural decomposition of leaf or plant matter, although it could suggest dung from livestock if the site environs are being used for grazing yet the lack of parasite ova may contradict the latter.

Revised aims and objectives for palaeoenvironmental research

Further processing of samples has the potential to clarify and test statements made on the variation of ecofactual and artefactual remains seen in samples from the south to the north of the site as a result of this assessment. However, the focus would be on Trenches 3, 4 and 5 where prehistoric activity is more prevalent. This would allow the characterisation of the compact stone layers to be strengthened and allow assessment of the relationship between these and other features in the Ribbon corridor. Although hand-collection of artefacts has already demonstrated differences between trenches, full sorting of residues including recording of weight (g) per 10 litre sub-sample will allow a more precise comparison of deposit make-up and will allow assessment, for example, of variation within extensive layers.

The following of the original objectives can be addressed:

- To further test the combined relationship, character and formation process of the Ribbon surface, intervening silt/other horizons, and the Ribbon construction cut (in so far as these components are collectively present along the monument as a whole)
- To assess the relationship of the Rotherwas Ribbon to other archaeological features in its vicinity including associated pits, the known earlier ditch, and the later ditches, and to interrogate the reason for the coincidence of these features in one corridor

4.6 Geoarchaeology (Mike Allen and Andrew Richards)

Background

Introduction

The onsite geoarchaeological context was recorded during a series of five site visits (Allen 2010), and this report outlines i) the geoarchaeological context of the 'Ribbon', and ii) the stone composition of the 'Ribbon'. The regularly site visits during the excavation aided in co-ordinating and focussing the palaeo-environmental and geoarchaeological field team (Appendix 1) and directing questioning towards the main project related-questions - see below (detailed in Appendix 2). Field visits enabled advice about palaeo-environmental sampling to be given to the field team, and facilitated the

recording of key profiles, and the recovery of accompanying undisturbed sediment samples through stone-dominated layers and ‘Ribbon’-related contexts. In addition a programme of cursory examination of the stones (clasts) thought to comprise the ‘Ribbon’ and related contexts was made in the field.

Terminology

The term ‘Ribbon’ has been employed by the archaeologists to largely describe the whole stone-dominated feature on the northern slope of Dinedor Hill. It is not, therefore, neither easily nor directly, applicable to individual stone-dominated layers which may, or may not form part of the ‘Ribbon’. ‘Ribbon’ is sparsely used and refers to the purported feature *en masse*.

There are a number of stone-dominated layers, some of which are clearly periglacially alerted, some are part of natural drift deposits, and others contain, and may be themselves, largely ‘archaeological’ and have been considered to be a part of the ‘Ribbon’.

As such the term ‘stone-dominated layers’ is used as a non-interpretive label for specific contexts which have been examined and described in an archaeological, geoarchaeological or clastic form.

This geoarchaeological assessment addresses a number of key topics, principally questions relating to the ‘Ribbon’ per se, and addresses following elements:

- Principally stone-dominated layer/s
- Buried geomorphological features associated with stone-dominated layers
- Former soils and soil/sediments matrix of the stone-dominated layers
- Sediment sequences overlying the stone-dominated layers

Assessment Aims

One of the main aims of this assessment is to assess and test analytical methodologies and approaches to resolving the complex intertwined, archaeological, geoarchaeological and sedimentological processes potentially involved with the creation of the stone-dominated layers, together forming a unit named the ‘Rotherwas Ribbon’. Thus this will define geoarchaeological and archaeological research questions, attempt to characterise the deposits, undertake small-scale analytical programmes and assess their usefulness in address the research questions, and propose a post-excavation strategy and programme. The aim of this assessment is not, therefore, to answer the key questions of the origin of the stone-dominated layers, but to provide a programme that can realistically attempt to do so.

The assessment report falls into several distinct sections, the analytical and review elements comprising : -

- *Geoarchaeological and Sedimentary context of the stone-dominated layers*
This includes a sediment summary by trench, and considerations of the sedimentary context
- *Geoarchaeology of the stone-dominated layers; stone composition*
Discussion of stone orientation and shape largely as recorded on site, and limited clast analysis by Andrew Richards
- *Discussion of the Geoarchaeological Landscape and stone-dominated Layers*
Discussion of the landscape features such as the palaeo-valley and the stone-dominated layers as a landscape feature
- *Discussion and Conclusions of the Geoarchaeology and Clast Assessments*

Archaeological Research Aims

One of the principal aims of the archaeological fieldwork project was to define the nature of the stone spread known as the 'Rotherwas Ribbon'. From previous work it had been intimated that the stone-dominated layers may have periglacial, natural drift geology outcrops or erosional origins – interpretations refuted by the on-site archaeologists. Archaeological fieldwork in 2010, and in particular the geoarchaeology, attempted determine if, or what element/s of, the 'Ribbon'/stone-dominated layers were anthropogenic, or could it wholly, or largely, be seen as a natural feature of the Rotherwas/Dinedor landscape?

The broader project and post-excavation geoarchaeological aims were to : -

- characterise and define the nature of clasts in the stone-dominated layer
- determine if this is natural fluvial/colluvial deposition, clastic slope flow, or an anthropogenic construct, or combination of natural and anthropogenic agencies
- determine if the stones are representative (in size, lithology and shape) of those in the immediately local landscape, and especially that upslope from which they may have derived via erosive action and subsequent deposition, or could not have accumulated via natural processes
- examine the matrix in which the stones are held
- define any preferential orientation, or depositional patterns which may aid determining deposition or emplacement modes
- identify any clear anthropogenic constructs or manuports
- define and characterise the nature of 'cut' in which the stone-dominated layers are situated with the aim of determining if this is a natural geographical/topographical feature or an anthropogenic construct

The aims of this assessment are in part to determine suitable methodologies for examining these complex integrated issues and to test if the methodologies suggested by the English Heritage advisors (i.e. clast analysis – A. Richards, below) can effectively address the questions about the natural and/or anthropogenic nature of the stone-dominated layers.

Geoarchaeological Questions posed as a result of fieldwork 2007 & 2010

More specifically, having examined the stone-dominated layer deposits in several locations the examination of the stones was to specifically address the following questions;

1. Is the deposit wholly, partly and not a product of natural processes of erosion and deposition?

Are the stone-dominated layers a product of periglacial clastic flow?

Are the stone-dominated layers products of periglacial cryoturbation?

Are the stone-dominated layers natural deposits resulting from the deposition in a stream, spring flush or erosion event OR

Are the stone-dominated layers a laid track/pathway/feature with both local material and material that has been imported and could not be a result of natural erosion and deposition processes, and thus is wholly man-made construct (possibly being a feature or even a pathway for human/animals upslope to or from the spring line) OR

Is the an essentially natural feature in origin that has been added to and enhanced (possibly making it a trackway), and into which natural additional stones have been brought and added to imbue the 'feature' with some significance

2. Is the deposit contained within or associated with any geomorphological features such as a now buried palaeo-valley? And does this relate to the natural deposition of stone-dominated layers, or was this landscape feature chosen for anthropogenic constructs?

3. The data that might help address these questions may include the following

i) what is the lithological composition of the samples

ii) what is the size range and shape

iii) how do these compare between our selected groups, and with the natural deposits

iv) are these stone assemblages typical of the natural outcrops

v) do these stone assemblages contain lithologies that are not present with the catchments of the stone-dominated layers and thus represent manuport?

- vi) do these stone assemblages show shape that is typical of natural deposits within the catchment of the ‘Ribbon’ or do they show shape characterises relating to erosion (roundedness) wear (roundedness or breakage and angularity), and could this be water erosion or anthropogenic and animal footfall?

Methods and methodological approach

A range of on-site recording and other analytical methods have been deployed and are assessed. On site full sedimentary records were made augmented by closer descriptions taken from monolith samples. Stone size, shape and orientation were recorded *in situ* in the field in 10 sample quadrats (by M. Allen). Some of these field methods were developed during the progress of excavation and in discussion with the English Heritage Advisors and Dr Keith Wilkinson, so where not consistent across all trenches (especially those excavated earlier). At the request of the English Heritage advisors a very large sampling programme of 100 litre bulk samples of stones were taken from many of the stone-dominated layers for clast analysis (see A. Richards below).

Outline geology and topography

Dinedor Hill overlooking the Wye valley dominates this landscape with the Rotherwas ‘Ribbon’ lying on its northern slopes. The Dinedor Hill ridge is comprised largely of Lower Old Red Sandstone (LORS); that is interbedded siltstones and mudstones of the Raglan Mudstone Formation. However, due to faulting, that on Dinedor immediately above Rotherwas, are interbedded purple, brown and green sandstones and red mudstones with intraformational conglomerates containing calcrete clasts forming alternating beds of clays and sandstones belonging to the St Maughan’s Group of the Maughan’s Formation. A number of streams and brooks and former streams such as Norton Brook and Red Brook, drain from Dinedor Hill and onto the Wye floodplain. This slope also contains drift deposits in the form of relict patches of sand and gravel of the Third and Fourth Terrace Deposits of the River Lugg and proto Wye. At the foot of the hill lies the Wye floodplain dominated by sands and gravels of the Second Terrace Deposits of the River Lugg and proto Wye. Geologically recent silt and clay alluvium are mapped along the courses of the Norton and Red Brooks. The ‘Ribbon’ occupies the lower slopes and footslope of Dinedor Hill, and the upper margin and edge of the Wye floodplain. The slopes generally support brown earth soils, with gleyic brown earths in the valley.

Geoarchaeological and Sedimentary context of the stone-dominated layers

A series of five trenches were cut perpendicular to the landscape orientation of stone-dominated layers on the northern slope of Dinedor Hill (trenches 1 and 2 south of the

relief road) and on the valley edge (trenches 3 to 5 north of the relief road). Thus trenches 1 and 2 were on the steeper slope, trench 3 in a footslope location, trench 4 at the base of the slope and edge of the valley, and trench 5 on the valley edge.

A total of eight key profiles were described in the field (Table 1, Appendix 3.1), and undisturbed sediment samples taken in monoliths from six key strategic and representative locations to augment geoarchaeological field record with more detailed descriptions made under laboratory conditions, and to facilitate subsampling should that be required. Most of the sampled profiles were of deposits sealing the stone-dominated layer. Pedological description employed the notation outlined by Hodgson (1976) and Munsell colours were recorded moist.

Undisturbed samples

A series of 8 profiles were described of which 6 were sampled as undisturbed sediments in monolith tins. They are listed in table 1, below, and full descriptions are given in Appendix 3.1.

Trench	Sample	Profile	depth	date	sampling
2	Monolith 1	1	26-76cm	10/02/10	50cm through stratigraphy above and below ribbon – contexts 3000, 3003, 3005, 3017, 3021
2	Kubiena 1	1	54-62cm	10/02/10	8cm through thin stony layer 3005, 3017, 3021
3	Monolith 181	2		9/03/10	50cm Through main deposits and 'soil' – contexts 3501, 3513(=3522), 3545 3514 and 3522
4	-	3			Main sequence - 4031, 4003, 4002
4	Monolith 176	4		9/03/10	50cm through soil next to palaeo-valley (south side) – taken by WHEAS, through context 4031, 4005, 4009, 4011, 4035
4	-	5			Sequence through buried soil in palaeo-valley 4031, 4004, 4024, 4025, 4026
4	Monolith 180	6		9/03/10	25cm through gravel /stony layer (north side), context 4009, 4011 and ?4031/4036
4	Monolith 186	7			-taken by WHEAS in AEA old monolith, contexts 4001, 4031, 4003, 4002, 4034
5	Monolith 199	8		16/3/10	50cm through deposits sealing stony layers; contexts 4507, 4534, 4532, 4532, 4515 and 4523

Table 4: *List of principle undisturbed deposit samples (see Appendix 3.1 for further geoarchaeological description and sub-sampling).*

Sediment Summaries by Trench

Geoarchaeological examination of the sediments, the deposit sequences and interfaces in the field, provides landscape context, basic characterisation and the basis for the interpretational framework for the location, formation or construction of the stone-dominated layers and their sedimentological history. These geoarchaeological data, combined with the archaeological context record, provide the basis for examining sediment architecture which embrace deposits associated with the stone-dominated layers. From this we can start to disentangle the anthropogenic components and actions related to and with it, from natural processes of deposition, colluviation and erosion that form part of its developmental history.

Trench 1 (10/02/10) south of road – Dinedor Hill, north slope

The section here revealed a brown earth over thin gravels (4th Terrace Deposits). No colluvium was present. A bulk sample of the natural gravel was taken as a control sample for the clast analysis. No detailed geoarchaeological descriptions were made of stone-dominated deposits in this trench.

Trench 2 (10/02/10) south of road – Dinedor Hill, base of north slope

The stratigraphy above and below was described (Appendix 3.1), and the full sequence sampled as an undisturbed monolith (Monolith 1) and the stone-dominated layer (3017) sampled as a small undisturbed sample (Kubiena 1), see Plate. The section revealed about 1m of stratigraphy and exposed a thin stony horizon which was equated by the excavators to the 'Ribbon', but the layer here was not clear or well-pronounced. The stone-dominated layer was sealed by shallow (c. 20cm thick) silty colluvium (context 3005).

This thin stony horizon (context 3017) overlies the weathered parent material and there is an abrupt boundary with no sign of either a former buried soil, or of pedogenesis associated with the stone stone-dominated layer. The matrix is essentially the same as the overlying colluvium, albeit slightly darker (?humic) and containing fine charcoal flecks absent from the overlying colluvium. The stony horizon here seems largely to be formed in colluvial material and been sealed by colluvium. There is no major observable distinction between the two horizons, excepting the observations made above.

Trench 3 (25/2/10) north of road – at footslope of Dinedor Hill

The stone-dominated layer here was sealed by c. 20cm of silty colluvium (3513=3522), whilst the stone-dominated layer itself (3514) was a coarser sandy silt loam with abundant to common small and medium randomly arranged stones, including occasional fire-cracked stones and medium rounded quartz stones. Significantly, the stones in profile seem randomly orientated, with some rounded flat stones being vertical (including in

monolith 181). This suggests that the last processes relating to deposition are unlikely to be fluvial and that some macro-bioturbation (?trampling) may have caused this disruption. Again the deposit lies abruptly on the weathered parent material with no signs of *in situ* or former pedogenesis. This sequence was sampled in 50cm long monolith 181.

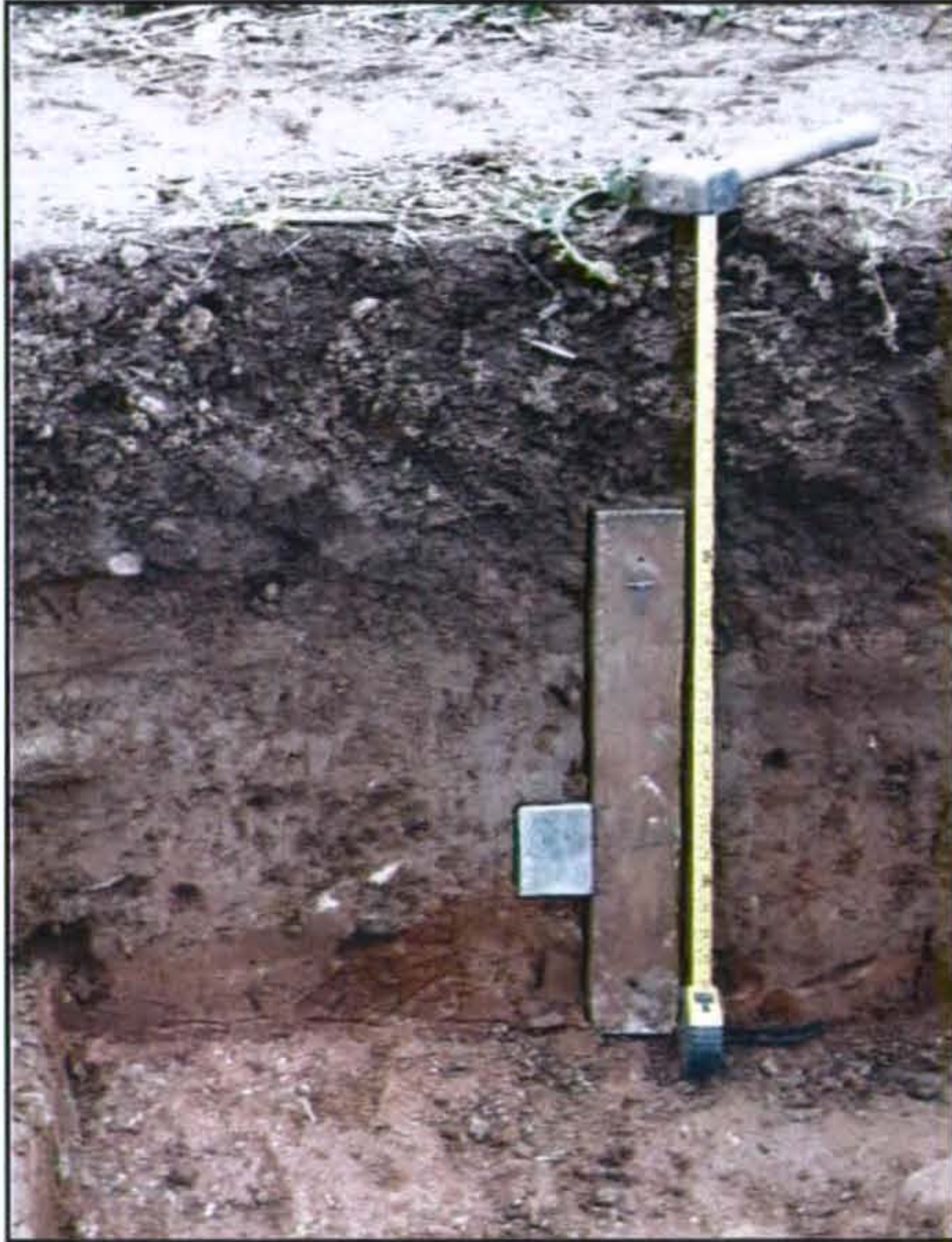

Plate 27: *Stratigraphy in trench 1 showing the location of Monolith 1 and Kubiena 2; the latter embracing the thin stony horizon equated by the excavators to the 'Ribbon'*

A broad shallow 'palaeo-valley' [3523] infilled by colluvium and bounded to the west by a gravel rise. The basal gravels (3552) of the palaeo-valley fine downwards with subrounded pebbles/fire-cracked stones/quartz on its surface. A lack of any finds associated with this deposits or surface. The cobbles have too great a mass for fluvial movement or wash downslope. Field observations suggest that this is reminiscent of a cobbled surface, or a surface which has been emplaced by the collection and accumulation of stones rather than a well-sorted fluvial or colluvio-fluvial deposits. Beneath the stone-dominated layer the parent material (3552) displayed weathered involutions and distinct stone striping separated by mottled silty clays, a relating to periglacial activity.

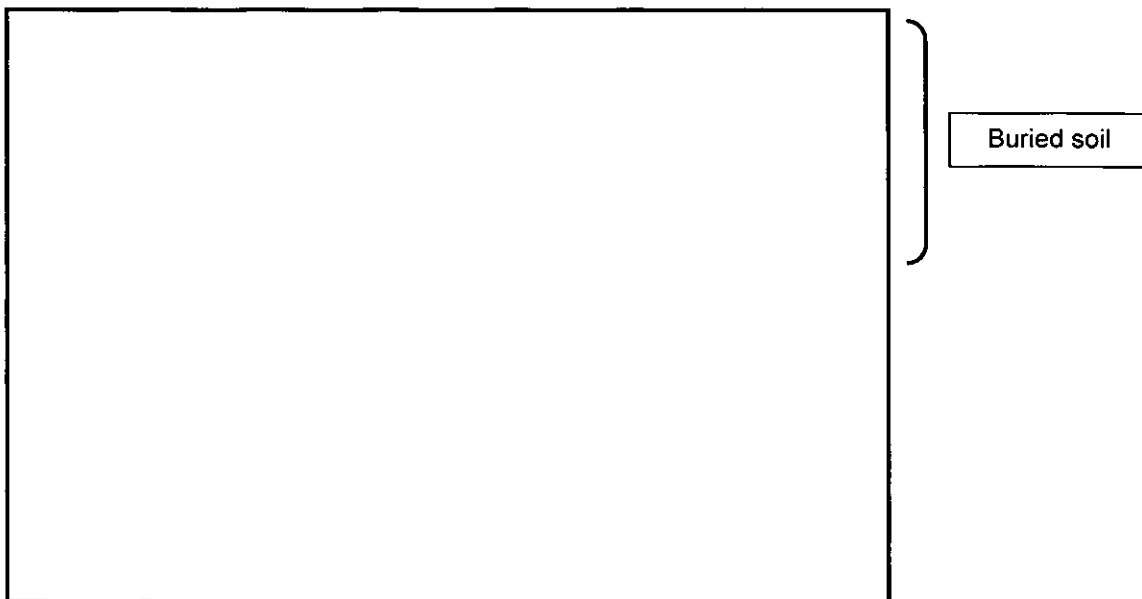

Plate 28: Buried soil developed in alluvium in trench 3. It marks a stabilisation and sealed with deposits which are more colluvial (hillwash) dominated.

Buried soil and ?Mesolithic/Bronze Age flint scatter: A possible continuation of the buried soil seen within the ancient palaeo-valley was that on its margins containing a scatter of ?Bronze Age worked flints. The soil also contained moderate, well-developed block to prismatic structure and a profile of a typical terrestrial brown earth soil under long term pasture. This was sampled in monolith 176.

Trench 5 north of road – on valley edge

The lowest trench in the catenary profile produced no real colluvial overburden being situated on the valley / floodplain edge above the furthest extent of flooding. The palaeo-valley was broad and shallow with possible braided fluvial flows. A range of gravel spreads and gravel surfaces were present (Fig. 3), some of which were clearly periglacially modified natural deposits. Some clearly part of the parent material (4523) others orientated and periglacially altered gravels (4520) with 'Ribbon'-ascribed deposits associated with the valley (4515 and 4534), bounded by gravel stone-rich bank (4510) – see Figure 3 and part 2, below.

Geoarchaeology of the stone-dominated layers; stone composition

Two approaches were taken to physically quantify and qualify the characteristics of the stone-dominated layers to aid in determining the anthropogenic vs natural component in its construction and formation history. The first approach was field-based *in situ* observations of stone size and orientation of the exposed surface undertaken by Dr Mike Allen. The second was statistical record of the lithology and size and shape characteristics of a selection of samples of the stones by Dr Andy Richards. The combination of these two studies aims at assessing and defining if the research questions (above and Appendix 2), can be answered, or what further analytical programmes are needed to address and answer those research questions.

Stone orientation and size of *in situ* deposits, spreads and stone-dominated layers

Methods

Basic records were made of the *in situ* stones by recording the number, size and shape of stones within several 0.5 × 0.5m quadrates, and details of 10 quadrates are given in Appendix 4. The dip of several medium sized stones was also recorded in all ten of these locations in an attempt to discern if the stones had any preferential bias which might be related to deposition. In one case a number of stones were on end and clearly oriented. Here preferential compass orientation was also recorded.

Stones >40-60mm were recorded. Stone size and shape followed terminology outlined in Hodgson (1976), and dip was measured with a small field abney level, and orientation via a magnetic compass. Stones measured for dip were principally medium stones. In addition the numbers of quartz and sandstone pieces within each quadrat were also recorded.

Assessment of the Results

It is clear that the type of surface stones varied (Plate 29, Table 5, and Appendix 4), and the presence of quartz in some seemed higher than the natural occurrence. The data is presented in the preliminary field records (Table 5). These data provide the basis of examining the composition of the stones and aiding in defining if deposition and formation was likely to be wholly natural, or whether these are natural deposits enhanced by, or entirely created by, human selection and deposition. The stone-dominated layers in each trench showed considerable variation down the Dinedor slope, and seemed to differ in nature (size, shape and lithological composition) from that of the exposed *in situ* natural gravels. The data presented in Appendix 4 now allows more rigorous comparison with both the assessment of clast analysis (below) and that of natural outcrops (see Recommendations and Proposals).

Trench	context	Total per 0.5x0.5m ²	% angular	% sub-angular	% sub-round	% rounded	mean dip	Mode	Orientation	No qtz	% qtz
3	3514b	99	0	4	96	0	3.7°	2°	-	1	1
3	3514	122	0	89	11	0	-	-	-	5	4
3	nat	42	0	86	10	5	10.1°	5.5°	-	0	0
4	4029	116	9	89	2	0	2.9°	1°	-	6	5
5	4504	171	0	100		0	1.4°	1°	-	1	0.6
5	4506	57	2	85	11	2	-	-	-	1	2
5	4514	61	0	82	18	0	2.7°	3°	-	1	2
5	4515	60	0	77	18	5	2.3°	3°	-	3	5
5	4520	117	0	4	93	3	46.1°	87°	353°	6	5
5	4531	23	0	70	30	0	-	-	-	0	0

Table 5: Summary of surface stone records

Plate 29 (overleaf): Selection of stone-dominated layer gravel components



Trench 5, context 4514

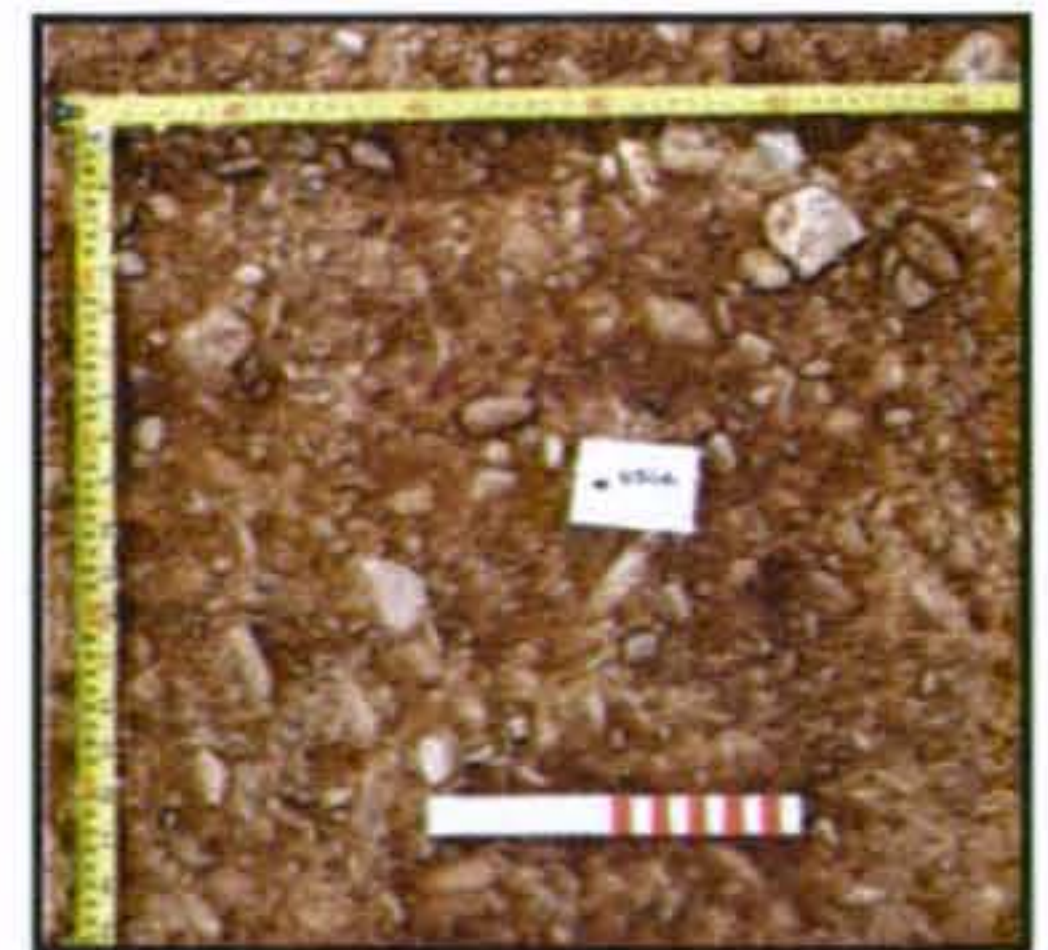

Trench 5, context 4504



Trench 5, context 4515

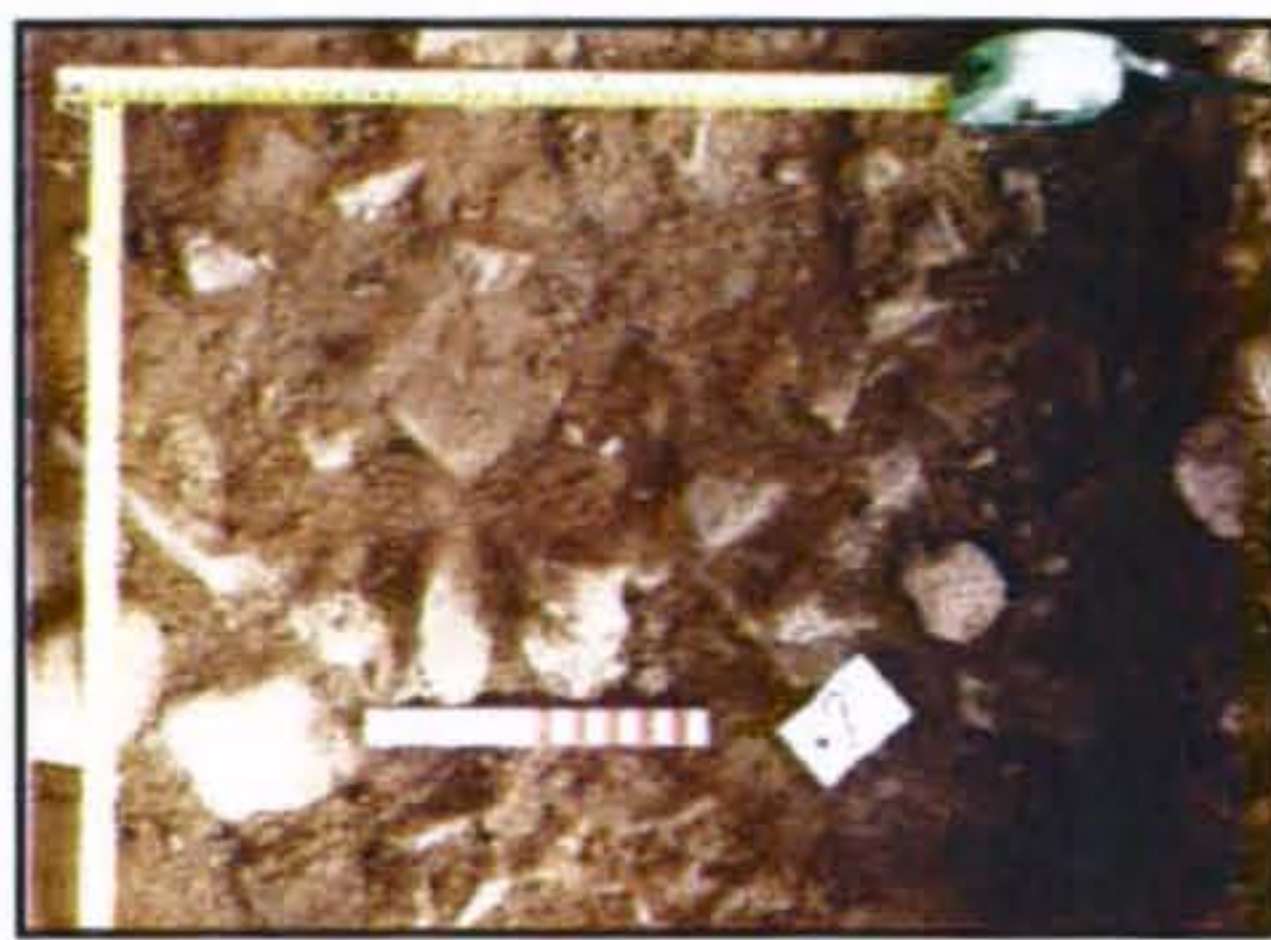

Trench 5, context 4531

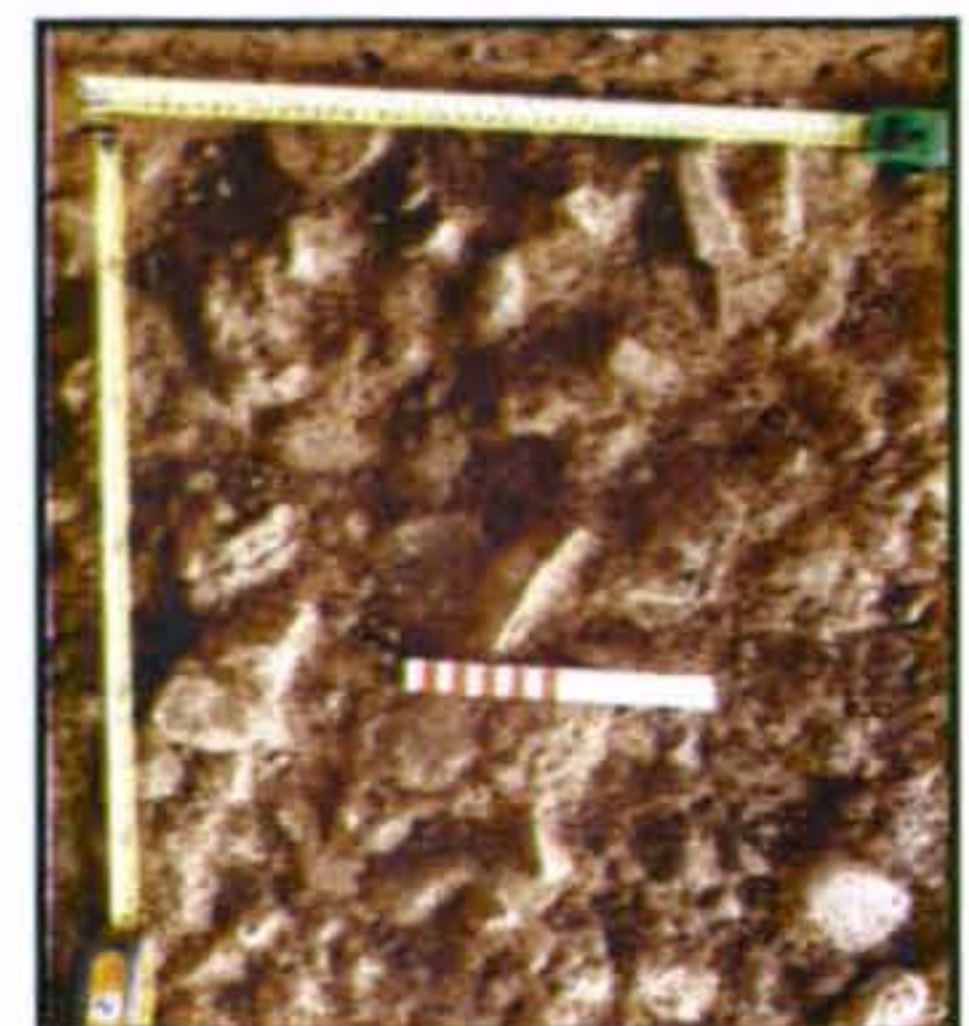

Whilst it is clear that periglacial action has resulted in frost action squeezing stones to a more vertical orientation in one context 4520 (trench 5), in most other contexts the examined stones lie flat or nearly flat (Table 5) and are similarly sized (Appendix 4). This reflects the characteristics of the source material. From preliminary assessment, therefore, surface stone shape and size do not seem to be key characteristics on their own, to differentiate the natural vs anthropogenic elements of the stone-dominated layers.

Clast analysis

Introduction and Methods (Michael J. Allen, Emily Beales & Liz Pearson)

A series of large (up to 100 litres) bulk samples were taken from the surface of the stone spreads and stone-dominated layers from each trench.

Samples were processed by wet sieving and the residues fractionated by Emily Beales at WHEAS following lithological analytical techniques recommend by Gale and Hoare (1991, 173-7) and is derived from Bridgland (1986, 14). For pragmatic reasons the samples were fractionated using nest of sieves available to WHEAS (some loaned by AEA: Allen Environmental Archaeology) approximating to phi size; these were 50mm, 25mm, 14mm 10mm and 5mm.

Phi size	= mm	suggested graded set using WEAS available sieves
-6 Ø (phi)	(64mm)	50mm
-5 Ø	(32mm)	25mm
-4 Ø	(16mm)	14mm
-3 Ø	(8mm)	10mm
-2 Ø	(4mm)	5mm

The number of clasts for analysis ideally should be about 250-300 minimum and preferably 500 per sample (Gale & Hoare 1991, 173). At least 3 samples clearly contained too few clasts (Table 6) and could not be selected for analysis.

For this assessment a series of 9 samples were selected, with at least one from each trench of stone-dominated layers. Lithological assessment by Dr A. Richards was conducted on the larger fractions only, i.e. >14mm. Roundness was recorded by Emily Beales (Appendix 5.1) following Hodgson (1976) and Gale and Hoare (1991).

Trench	Sampled contexts	Total available samples	Total assessed
Tr 1:	<u>1000 control</u> <u>2511</u> , (<u>2517</u>), 2529*, 2531*, (<u>2532</u>)	1 5 (less 2 too few clasts)	(1 proposed) 2
Tr 2:	(<u>3006</u>), 3016, (<u>3017</u>)	3	2
Tr 3:	<u>3513</u> (=3522), 3524, 3546 [process <u>3514</u>]	3	0 (2 proposed)
Tr 4:	(<u>4008</u>), (<u>4011</u>), 4018*, (<u>4028</u>), (<u>4029</u>)	5 (less 1 too few clasts)	4
Tr 5:	(<u>4515</u>), <u>4534</u>	2	1 (+1 proposed)
	Totals	19 (less 3)	9 (+3)

* = too few clasts for analysis

Table 6. List of clast samples taken. Those analysed by Andrew Richards are underlined in parentheses, and those proposed for analysis are just underlined

Trench	context	Summary interpretive description provided by archaeological team
Tr 1:	2511	Lower metalled surface
	2517	=2532 metalled surface
	2529*	More compact stone with depth (after removal of 2528)
	2531*	Fill of Cut 230
	2532	Metalled surface
Tr 2	3006	Compact stone surface
	3016	Lens of sandy silt in base of Cut 3018
	3017	Metalled surface
Tr 3	<u>3513/3522</u>	Layer of sand and silt (colluvium) same as 3522)
	<u>3514</u>	Stone surface (metalled)
	3524	Silty fill of ditch 3512 (same as 3510?)
	3546	Redeposited natural
Tr 4	4008	Primary deposit of palaeochannel 4027
	4011	Base deposit channel 4027
	4018	Silty sand between 4013 and 4019
	2028	Gravel patch
	4029	Natural gravel
Tr 5	4515	Compact metalled surface ('ribbon')
	4534	Narrow compact stone band (middle surface)

Table 7: List of context descriptions and archaeological interpretations

Lithological and Shape characteristics of gravel samples from stone-dominated layers
(Andrew Richards)

The following report outlines the lithological composition and shape characteristics of gravel obtained from the nine samples assessed site and compares their characteristics to local Pleistocene deposits. The nature and context of Pleistocene gravels surrounding the study site will be discussed, followed by analysis and interpretation of the data obtained.

Finally, recommendations will be made regarding future analysis. The raw data and statistical analysis are appended at the end of the report.

The characteristics of Quaternary deposits in the local area

There are two main Pleistocene units that occur near the site of the excavations; the Holme Lacy Member (4th Terrace) and the Bullingham Member (2nd Terrace) of the Wye Valley Formation (Hey 1991; Maddy 1999).

The Holme Lacy Member has a type area at Holme Lacy (SO 555355) where a large undissected terrace remnant occurs. Other deposits, correlated with this Member occur on the southern margins of Hereford City at Bullinghope (SO 507375), Green Crize (SO 515372, 517375) and Dinedor (SO 539371). The base of the terrace deposits lie about 20-30m above the present floodplain (65-75mOD). The lithological composition of these units is shown in tables 8 and 9. The deposits exhibit a large degree of variation. While similar lithologies are present at each location, the sedimentology of the gravels appears to differ. The Type Site is poorly exposed in an old railway cutting near the former site of Holme Lacy station (SO 552356). Here, well sorted subrounded to rounded and often tabular gravels are interbedded with silt and sand. Clasts are predominantly of Welsh origin, with conspicuous vein quartz and greywacke. The terrace remnants at Dinedor (SO 539371) are not exposed, but augered samples suggest that gravels at this location are composed of the same lithologies, and have the same sorting and shape characteristics to the gravels exposed at Holme Lacy.

The Holme Lacy Member was also exposed during excavations made during the construction of the Rotherwas relief road at Green Crize (SO 515368). Sections exposed up to 1.5 metres of relatively well-sorted, horizontally bedded coarse gravels containing sub-rounded gravels from 20-120mm. These units are overlain by up to 3 metres of massive, sub-horizontally bedded poorly-sorted gravel, containing angular to subrounded clasts from 50-300mm. The clasts have a chaotic arrangement, with no defined imbrication or other internal sedimentary structure. Locally, there are intermittent beds and lenses of coarse grained sands and crudely sorted gravels with syndepositional active and passive faulting which often distorts apparent trough and planar cross-beds. In general the primary sedimentary structures present indicate low relief bedforms common in sandur deposits. The upper 1.4 metres of the coarse, poorly sorted gravels have been deformed into a range of amorphous features. Finer sediments from underlying gravels have been injected into overlying deposits and prolate clasts are often vertically-inclined at the margins of crude festoons and ball-and-pillow structures. Such features are typical of cryoturbation under intense periglacial conditions. Both gravel units contain a similar lithological suite to that recorded at Holme Lacy, with a marked increase in the

proportion of locally-derived Lower Old Red Sandstone material. The variation in the sedimentology of the Holme Lacy Member may suggest that the Member may require further stratigraphic subdivision. It is possible that more than one phase of aggradation is recorded in the member. While the gravels at Holme Lacy and Green Crize both accumulated under cold conditions, the latter are distinct in that their sedimentology may indicate the proximity of an ice-sheet and subsequent, intensely cold conditions- perhaps with a mean annual temperature of less than -6°C (French and Williams 2007). If the altitudinal correlation of the Holme Lacy Member with the Bushley Green Member of the Severn Valley Formation (Hey 1991) is correct, the sediments at Green Crize may record the incursion of an icesheet into the Hereford Basin during Marine Oxygen Isotope Stage 8, ~350kaBP.

The Bullingham Member (Type Area SO 501388 to 529374) was temporarily exposed during excavations for a gas pipeline at Rotherwas (SO 532378). The member lies at 53-54m above OD, 4.5 to 6m above the present floodplain. The 4.5m section exposed tabular, laterally extensive units of massive to planar bedded gravel up to 70cm in thickness, and tabular cross-bedded gravel units 10-40cm in thickness. The upper 1.5 metres of the section includes interbeds of 10-15cm thick planar crossbedded sand. As a whole, the sediments probably represent parts of in-valley unit bar, and later supra-bar and bar tail deposition within a periglacial, braided river system. The lithological characteristics of these sediments is shown in tables 4 and 5.

Analysis

Lithological and roundness analysis followed the methodology given in Gale and Hoare (1991).

Roundness characteristics

Roundness is determined by the abrasion of the particles during transport and varies with the transportation distance and energy. The rounder the clast is, the more likely the pebble has spent a significant time transported by water, usually rolled along the stream bed as traction load. More angular sediments indicate either a low amount of agitation, or a short distance of transportation from the time the particle weathered or broke away from their parent rocks - by a chemical or physical process. A high-energy environment, which allows for a long period of exposure to weathering, such as a beach or in a stream, is conducive to the formation of 'well-rounded' sediments. On the other hand, a high-energy depositional environment that does not allow a long period of exposure to agitation, such as an alluvial fan, prevents the sediments from becoming 'well-rounded'.

trench	1	1	2	2	4	4	4	4	5						
	2517	2532	3006	3017	4008	4011	4028	4029	4515	Green Crize, lower gravel unit 1	Green Crize, lower gravel unit 2	crypturbated gravel unit 1	crypturbated gravel unit 2	Rotherwas lower gravels	Rotherwas upper gravels
gw	25	24	63	68	64	82	29	47	67	187	150	170	156	170	170
silt/sh	10	8	12	15	35	64	17	26	28	55	40	50	50	50	61
sst	9	7	26	27	12	20	8	7	12	38	33	34	37	34	38
qtz	1	1	2	0	12	25	6	6	5	14	12	13	13	24	22
ig	1	1	4	2	3	3	1	1	3	10	13	14	12	24	31
ors	128	99	98	64	8	13	4	6	6	84	82	92	79	34	29

KEY: Gw greywacke; silt/sh silt/shale; sst sandstone; qtz quartz; ig igneous; ors old red sandstone

Table 8: Lithological composition of coarse gravel fraction

trench	1	1	2	2	4	4	4	4	5						
	2517	2532	3006	3017	4008	4011	4028	4029	4515	Green Crize, lower gravel unit 1	Green Crize, lower gravel unit 2	crypturbated gravel unit 1	crypturbated gravel unit 2	Rotherwas lower gravels	Rotherwas upper gravels
gw	20	8	52	74	331	91	90	112	132	205	188	222	201	241	253
silt/sh	8	3	8	15	158	33	27	41	49	66	55	72	67	79	84
sst	6	2	22	44	75	21	19	33	25	44	41	45	44	45	45
qtz	1	0	1	0	42	13	12	16	11	18	12	11	15	26	28
ig	1	0	2	4	12	5	6	13	5	17	12	26	17	36	37
ors	114	36	67	75	47	15	15	32	17	79	85	109	102	36	43

KEY: Gw greywacke; silt/sh silt/shale; sst sandstone; qtz quartz; ig igneous; ors old red sandstone

Table 9: Lithological composition of finer gravel fraction

The sediments obtained from trenches 1 and 2 are, in general markedly more angular than those from other sites (Appendix 5.6). Clasts obtained from trench 4 tend to be subrounded, although there is a marked increase in the angularity of clasts in the finer fractions of the sample of context 4008.

In general terms, the roundness characteristics of the sediments sampled from trench 4 are typical of the cold stage terrace deposits that form the Wye and Lugg Valley Formations. These sediments are thought to have accumulated in a high discharge, periglacial river system with gravels accumulating as parts of in-valley unit bar, and later supra-bar and bar tail deposits. The roundness characteristics of clasts obtained from trenches 1 and 2 suggest shorter transport distances and entrainment within a glacial or

periglacial environment, or possibly manual excavation of locally derived materials. The roundness characteristics of sample of context 4008 differs from that of other samples obtained from trench 4 in that there is a marked increase in the angularity of clasts in the finer fractions, which is at variance with the dominantly subrounded nature of the coarse components of the unit. There is a gradual increase in angularity of clasts within sample 4008, with decreased clast size. If the sample can be assumed to have been taken from a single, discrete, sedimentary unit, the only natural process that could explain subrounded clasts within an angular matrix would be associated with a mass movement (hillslope) process that entrained sediments from two distinct sources.

Lithological characteristics

The 25mm (coarser) and 14mm (finer) fractions of the samples taken from trenches 1, 2, 4 and 5 were assessed for their lithological composition. Clasts were grouped into 6 categories; Lower Palaeozoic greywackes (turbiditic sandstones derived from Upper Ordovician, Upper Llandovery and Wenlock Formations of central Wales); Lower Palaeozoic, fine-grained siltstones and shales (largely tabular clasts); Lower Palaeozoic sandstones (possibly Ludlow series, derived from NE or from central Wales); fine grained igneous material; Lower Paleozoic vein quartz; and sandstones, siltstones, mudstones and limestone nodules from the Raglan and St Maughan's Formation of the Lower Old Red Sandstone.

The lithological data obtained from the trenches was then compared to lithological data from two remnants of the Holme Lacy Member (Holme Lacy railway cutting and at Green Crize, immediately south of the study site, 2007) and the composition of the Bullingham Member (temporarily exposed during excavations for the Rotherwas relief road, 2007). The sediments obtained from Green Crize and Rotherwas document the sedimentological and lithological variability of sediments that have been mapped as the Holme Lacy Member (4th Terrace) by the British Geological Survey. The composition of the latter appears to be more typical of the fluvial gravels of the Wye Valley Formation. Comparisons were made using a variety of descriptive statistics, Pearson Product Moment Correlation, Factor Analysis and Cluster analysis.

The principal factor that differentiates the units is an inverse relationship between the amount of locally derived ORS material when compared to the number of Lower Palaeozoic turbiditic sandstones. The second strongest influence on the lithological variability of the dataset is determined by an increase of quartz and tabular siltstone/shale clasts (Appendix 5.2 and 5.4). These factors are consistent, irrespective of the size of size fraction under analysis. Factor analysis and Cluster analysis distinguishes a number of groupings (Appendix 5.2 and 5.5). The trench material is characterised by higher relative

proportions of locally derived clasts, like the glacially-derived materials sampled from Green Crize. Although samples obtained from trench 4 show similar relative proportions of Quartzite tabular siltstone/shale clasts to Both the Holme Lacy and Bullingham (Rotherwas) samples, sample 4008 (and to an extent sample of context 4011) shows a much more pronounced increase in shale, fine siltstone and, particularly, quartz clasts.

In summary:

- the sediments from trenches 1, 2, and 5 are markedly different from trench 4 and the samples from the Holme Lacy and Bullingham Members characterised by much higher proportions of locally derived material.
- Samples obtained from trench 4 are similar to local terrace deposits, but share most similarity with the non-glacigenic members of the Wye Valley Formation. This is characterised by similar relative proportions of Lower Palaeozoic material.
- In the finer gravel fraction, there is a marked increase in Silurian siltstones/shales and quartz clasts in sample of context 4008. There is also a marked increase of quartz in the coarser fraction of sample of context 4011 when compared with other trench samples and the non-glacigenic/ glacigenic units of the Wye Valley Formation.

Bearing of results on research questions

The samples obtained from trenches 1 and 2 consist mainly of locally derived, subangular clasts. These sediments differ from the gravels obtained from trench 4. Their occurrence, lithological composition and shape characteristics suggest that they accumulated in the upper courses of a small fluvial system which drained the northern slopes of Dinedor Hill. The far travelled, Silurian, components are likely to have been reworked from pre-existing gravels. The friability of the local sandstone clasts that dominate these sediments suggest that the water course may have been in place for a relatively short period.

The shape characteristics and lithological composition of the gravels of trench 4 bear great similarity to the non-glacigenic gravels of the Bullingham and Holme Lacy Members of the Wye Valley Formation. It is possible that these gravels are a natural remnant of the Formation, as mapped by the BGS. However, samples of contexts 4008 and 4011 differ from gravels obtained from the trenches or the Wye Valley Formation. 4008 contains a greater proportion of subangular fine gravel; very fine-grained siltstone; and quartz. 4011 is also marked by an increase in quartz clasts. While it is possible to suggest that a hillslope process, such as a cohesive flow, could mix distinct pre-existing gravels to produce a single unit with rounded to subrounded coarse gravels within a angular to subangular matrix, this is unlikely given the topography, the limited catchment area available for such a catastrophic flow and the deposits stratigraphic relationships. It

is also very difficult to explain why quartz and tabular siltstone/shale clasts show a marked increase in this deposit, when these lithologies have an identical source area to the Lower Palaeozoic greywackes and sandstones that dominate the Pleistocene deposits of the area. One would expect an increase in either quartz, Silurian shales or siltstones to be accompanied by a concomitant increase in other Lower Palaeozoic materials. The simplest explanation would be that these gravels have been modified at the site.

From the data available, these results would suggest that the stone-dominated layers may be partly natural. They certainly have a source from the Wye Valley Formation. However, there is evidence to suggest that some levels of the sediments have been modified and that manuport and *in situ* human modification of certain lithological components.

Discussion of the Geoarchaeological Landscape and Stone-dominated Layers

The palaeo-valley

The topographic form of the palaeo-valley largely dictates the course of the stone-dominated layers, certainly in its northern and downslope portions. The palaeo-valley has geological and pre-Holocene origins (see trench 3), but clearly would provide an avenue for both overland water and sediment flow. The valley is more pronounced in the lower footslope locations, but its origin is likely to be the spring line on Dinedor Hill.

A number of the stones in the stone-dominated layers clearly been derived from stones available within the immediate catchment and through which the palaeo-valley traverses (see clast analysis, A. Richards above). Some of the stone-dominated layers are, however, not on the floor of the valley, but on higher dried ground on its margins and edges, and some of the gravel spreads are only in part reminiscent of naturally re-worked material.

It seems likely that during the Holocene period (i.e. prehistory) the valley was the route of season water flushes from the spring line on Dinedor Hill. As such the lower water course in particular may be marked by a concentration of stones either deposited or exposed by the removable of the sedimentary matrix, and during the summer months would provide an idea dry path and routeway to the spinglines and Dinedor Hill. Such an import communication access routeway for both humans and animals may then be reinforced and enhanced by the addition of both stones recovered locally, and possibly by other manuports. The fieldwork evidence briefly reviewed to this date does not contradict this type of hypothesis. Stone-rich deposits within clearly defined palaeo-valleys in trench 4 were isolated by stone analysis (Richards above) as having been “in the upper courses of a small fluvial system which drained the northern slopes of Dinedor Hill”.

Considerations of the stone-dominated layers; their location, nature and observed composition

The gravels of the stone-dominated layers seem to follow the natural valley-form up the Dinedor hillside to trench 2 at least. Much of the material is locally derived – i.e. material washed down possibly a temporary and seasonal water route, but the stone assemblages as excavated seem to have been modified on site. The dense packing and mixed nature of the stones is more reminiscent of trackways and routeways compacted by foot falls of animal or human traffic. In some places it superficially resembles the ‘avenue ‘metalling’ of the Durrington Avenue. On balance, provisional thoughts are that this may be in part stones accumulated (possibly within a natural water flush line), but seems to have been enhanced by the addition of stone and this could be to make a clear routeway upslope and towards the spring line. The occurrences of quartz, for instance, seems to be over and above the natural occurrence and this may suggest the inclusion of manuports – or even specifically selected stones. Stone lithology of the coarse fraction (i.e. that which may include manuports) seems to be the most distinguishing feature.

The extent, distribution, thickness and lack of random orientation (see Table 2) and stratigraphic location of most of the stone-dominated layers precludes them being principally originated from periglacial clastic flows.

Discussion and Conclusions of the Geoarchaeology and Clast Assessments

The analytical assessment (stone orientation and in particular roundness and lithology) have clearly indicated a potential to aid in characterise and interoperating the nature of the deposits. These characteristics themselves, cannot provide definite interpretation, but can contribute to the overall interpretations, which require a combination of geoarchaeological field records, lithological analysis and archaeological observations to make an informed interpretations. No single analytical method can, on its own, provide a definite answer to these superficially simple questions, which are clearly reflect potentially quite complex and highly dynamic processes and histories.

Summary Conclusions of the Geoarchaeological and Sedimentary context of the stone-dominated layers

The sediment record here compares well with that recorded by Keith Wilkinson (2009) from the 2006-07 excavation of the ‘Ribbon’ along the Rotherwas Access Road (Sworn 2009).

The stone-dominated layers as such were laid on the weathered natural parent material, or erosion products, with no evidence of it lying on, or sealing a former soil, or of the stones comprising the stone-dominated layers being incorporated into a former soil. We conclude that the stones were emplaced on areas largely stripped of soil, or that the physical and/or biotic activity after deposition and emplacement has resulted in truncation and removal of the former soil as the stones became worked into this horizon and the soil/sedimentary matrix lost. A process seen in both stony fluvial flush surfaces, and muddy pathways which are enhanced with the additions of pebbles and stones.

The nature of the stone-dominated layer and the stone matrix is examined in part 2, below. However it was clear on site that stone-rich deposits present in trench 4 differed from those elsewhere and that these were palaeo-valley deposits rather than deposits associated with stone-dominated layers.

Deposits sealing stone-dominated layers are either the base of the current soil profile (typical brown earths or colluvial brown earths), or colluvium, which post date the final deposition, use, exposure and abandonment of the 'Ribbon'. Colluvial deposits are thickest and most differentiated at the footslope locations. The silty colluvium is largely stone-free and broadly homogenous, and generally coarsens down profile, and upslope. No stasis or obvious sedimentary breaks were seen within the colluvial unit such as buried soils or obvious fluvial episodes. If the stones in the stone-dominated layer were deposited by a fluvial action, it is clear that those processes of deposition, if not of fluvial flow itself, ceased and did not re-occur during the post-'Ribbon' phase of colluviation. The often abrupt contact between the stone-dominated layers the colluvial unit might indicate a rapid change in land-use and associated activities. There is no indication of later archaeological activities or sedimentary stases within any of the colluvial profiles.

The concentration of stone-dominated layers seem to follow the line of former large ancient palaeo-valley that still formed a broad shallow hollow or valley which became infilled with alluvial and colluvial deposits.

Assessment Conclusions

Methods of Analysis

The questions of formation and deposition of the stone-dominated layers recorded in the field are inextricably linked to their taphonomy and may include complex processes and events of combinations of natural and/or anthropogenic deposition, erosion, reworking and transformation. As such geographical processes and events are not always easily identified, nor are strictly anthropogenic deposits.

It is clear, therefore, that no single geoarchaeological approach will affect clear unambiguous answers to the basic research questions posed. Nor is it likely that geoarchaeological enquiry alone will provide unambiguous answers, but that interpretation will be via a combination of geoarchaeological data and archaeological comparison and information.

It is therefore necessary to create an criteria matrix with which to compare the relevant sets of data and information and from which to make an informed interpretation.

The assessment above, however, clearly shows that stone lithology and roundness characteristics are different and analysis separated deposits in trench 4 relating to the palaeo-valley from all other trenches.

Field Records

The field records of the contextual situation and of the stone size and orientation has aided in characterisation of the various stone-dominated layers and in providing a good geoarchaeological record which will assist in the final interpretation

Stone size and shape (in comparison with local drift geology outcrops)

This analytical elements on selected samples has clearly provided an important comparator with local drift geologies, and with further local references, and analysis of few other selected contexts provides a basic plank in the interpretational record.

Clast lithology (in comparison with local drift geology outcrops)

The geological identification also provides an important comparator with local drift geologies and in particular of those within the erosion catchment area of the stone-dominated layers sampled. The casual observations and indications of higher percentage occurrence of specific notable rocks (e.g. quartz), has been quantified against its natural occurrence to define if any anthropogenic addition is likely. Again with further local reference samples, and analysis of few other selected contexts provides a crucial part in the interpretational of anthropogenic vs natural agencies.

Discussion of geoarchaeological assessment results/implications

From the field observation from five exposures spread across the foot of Dinedor Hill, in combination with the limited geoarchaeological analytical assessment programmes

conducted we can already clarify some of the questions originally posed, and make distinct headway in refining, and defining an appropriate post-excavation research programme.

Geoarchaeological Setting:

it is clear that the stone-dominated layers seem in part to occur in, or be concentrated within a largely infilled palaeo-valley
the stone-dominated layers themselves vary considerably both with exposures (i.e. trenches) and between them
stone-dominated layers do not seal a clear buried soil
they are discontinuous, disrupted and not typical of a periglacial clastic flow

Stones of the stone-dominated layers:

None of stone-dominated layers are the product of periglacial cryoturbation *per se*, but some areas in trench 5 show *in situ* freeze-thaw indicating that this deposit is likely to be a part of the weathered natural drift geology (e.g. context 4520, trench 5 – see orientation records table 2)

The stone-sizes recorded in the upper part of the Dinedor slope profile (i.e. trenches 1 and 2), are highly unlikely to have been a result of waterborne deposition as the head above the trenches is too small to provide the kinetic energy to entrain stones of this size. We cannot preclude that stone-dominated layers in other trenches are not in part waterlain, and those in trench 4 have characteristics which are compatible with this type of deposition

Stone-shape in most trenches do not indicate heavy fluvial transport or wear.

Criteria Matrix

As indicated above, one of the key tasks during the post-excavation phase is the creation of a criteria matrix defining sets of observations or information that would be expected in natural and anthropogenic layers. These criteria can then be used to judge the recorded geoarchaeological and archaeological data to weigh the evidence and ultimately to provide an informed interpretation. This information can now be better defined having undertaken the geoarchaeological and archaeological assessment and removed some of the other rather basic and more fundamental possibilities – such as a periglacial origin of the stone-dominated layers.

Acknowledgements

The samples were processed at WEAS by Emily Beales and the programme managed by Liz Pearson. Advice on site was given by Drs Matt Canti and Keith Wilkinson, and

advice on the clast assessment programme was provided by Keith Wilkinson. Clast analysis was conducted by Dr Andy Richards who visited and undertook work on the previous stage of fieldwork. Thanks to Dai Williams and Ian Bapty (Hereford) and Robin Jackson (Worcester) for contextual information and fruitful informative discussions.

5. DISCUSSION AND RECOMMENDATIONS

5.1 Towards A Combined Interpretation

The purpose of this report is to define the next analytical stage of the Rotherwas Ribbon investigation project, not to attempt any comprehensive interpretation or integration of the range of data which is now available. However, in order to focus the further post excavation analyses, and the wider intellectual interpretative process which accompanies that, it is nevertheless appropriate to attempt to establish some broader interpretative perspectives. One significant advantage of doing that now is that those perspectives can form part of the peer discussion process which will flow from this document, and which will thereby help to inform the completion and content of the final report.

Re-assembling the evidence

One of the key discussions which emerged following the 2007 discovery of the Rotherwas Ribbon (and which closely informed the aims of the present project) concerned the precise origin of the feature, and, in particular, the relative balance of cultural and geomorphological processes in its creation and/or its appearance as it exists today. Taking into account all the preliminary analyses, the evidence from Trench 3 in particular (the one trench where the 2007 Ribbon was almost certainly re-identified) supports the view that the Rotherwas Ribbon – or at least the stone surface element of the structure – was created in a cultural context (most likely in the Neolithic or Early Bronze Age), and that the process involved directed cultural action with the intention of producing an artificial or largely artificial feature substantially as we see it today.

The relationship of the stone surface features in other trenches to the Ribbon (as present in Trench 3/the 2007 excavation) remains unclear and is based substantially upon overt similarities in the form of the observed surface(s). However, the preliminary analysis of the additional stratified artefact material variously associated with the deposits in those trenches – including, in particular, the flint assemblages from Trenches 3, 4 and 5, and the Bronze Age pottery assemblage from Trench 5 – has further emphasised that significant early prehistoric activity was occurring in this zone, and moreover was occurring in direct association with several of the stone surfaces in or adjacent to the hollows. The burnt mound in Trench 5, and the discovery of the later Roman/late settlement (elements of which could very well have later prehistoric origins) has significantly emphasised the longer term settlement story, and may also help to contextualise the later ditches which were found in Trenches 1- 4.

What has now been equally emphasised, especially by the preliminary results of the geoarchaeological work (and, to a degree, the results of the environmental remains analyses), is that the wider natural landscape context, and the natural processes operating in that landscape, are also likely to be a key part of the story. The palaeochannel in Trench 4 is active in broadly the same chronological context as the Ribbon (as identified in Trench 3 and 2007), and must have been a prominent feature in the same immediate landscape. That fact alone emphasises the likelihood of some degree of direct or indirect

relationship between water action processes and the hollow/channel features also observed in Trenches 1, 2, 3 and 5 (and with which further stone dominated layers/surfaces are associated), and a more detailed understanding of some of those processes is emerging within the georcalheological and palaeoenvironmental analyses. More detailed characterisation of the lithological and compositional differences between the respective surfaces, and with respect to the geological sources of this material, has also begun to emphasis distinctions which may be significant in understanding the relative relationship of these features, and the extent to which they result from common formative processes (whether natural or cultural) or otherwise.

However, the issue of overall interpretation is by no means more straightforward than it was before work began. In this regard, it is important to note that the deposits in each trench are as much marked by their differences as their similarities. Bearing in mind the caveats concerning ‘key-hole’ investigation, the uncertain significance of the geophysics results, and the relevance of later truncation effects in this wider landscape, it remains a potentially misleading exercise to connect the disparate features across the five trenches and the 2007 excavation into a common whole. So, for example, the presence of a coherent ‘palaeo-valley’ (as suggested by the geomorphological analysis) is still to be evidentially demonstrated, and even if activity (both cultural and natural) is being focused along this corridor by such a feature (a perfectly plausible model), then the precise origin of that feature also remains to be demonstrated, and could yet be bound up with cultural activity from the outset. The chronology/dating is obviously very important in this discussion, and arguably this is the most important additional source of data still to be obtained. Although it has been suggested that the notional palaeo-valley most likely has a significantly earlier origin than some the deposits which lie directly in the base of it, that does need to be evidentially tested, and the OSL data are potentially significant in this respect.

The integrated interpretation of the lithological analyses potentially involves similar complexity. For example, the differential incidence of some stone types as against their occurrence in local geological contexts – most notably the amount of quartz in the Trench 3 ‘Ribbon’ surface and elsewhere - has emphasised the significant probable role of human action in the creation of these features. However, across the various surfaces the stone is generally of unmodified shape and form compared to the natural sources. A stone surface which is entirely made by people using material collected from a readily available local source will, in these terms, have no significant difference from the same surface as re-deposited by some form of water action, and the truth is that such analyses cannot be used in any simple or deterministic way.

An important comparative source which must not be overlooked in the re-interpretation process is, of course, the information from the original 2007 excavation. This remains the only spatially extensive exposure of the Ribbon permitting the full range of details to be seen in context, and including several details which were not duplicated in the present excavation (whether in Trench 3 or elsewhere). Seen over a 67 metre length, key characteristics included the undulation of the surface, the uniform ‘metalled/cobbled’ make-up of the surface throughout, the defined edges to the surface, the markedly varying

width of the surface, the fact that the surface did not completely occupy the hollow (or its lowest areas), the localised zone of ‘upper surface’ with a defined ‘step’ on one side, the linear charcoal spread onto one area of the surface, the presence of the eight adjacent burnt-stone filled pits, and the significant associated artefact and bone assemblage.

Any interpretation of the present evidence must also explicitly engage with and explain all this known detail, and beyond that, recognise that such deposits and patterns do seem to be highly unusual both in terms of any recorded geomorphological process, and within the repertoire of prehistoric ‘paving’ of Late Neolithic/Early Bronze Age date (although reference the ‘paved’ area outside the south-east entrance of Durrington Walls). If the explanation is ultimately a relatively ‘simple’ one – such as that the Ribbon surface was created by the addition of extra stone fill to a natural landscape corridor where some stone has already accumulated through down-slope water action, so creating a convenient pathway – then it has to be asked why such pathways are not being observed in many places and in many different archaeological contexts. Moreover, how far does that explanation really mesh with the pattern of the Rotherwas Ribbon as identified in 2007? Interestingly, the Roman associated surfaces in Trenches 1 and 2 with their accompanying ditches do look like path-ways and trackways, but they are also significantly different to the Ribbon as observed in 2007 and in Trench 3 precisely in their lack of surface conformity (and they appear to have a direct relationship to a nearby settlement).

In essence, there is now a significant resource of new evidence, increasing understanding of some components of that evidence, but still no very convincing explanatory models to pull all that material together. What is clear is that understanding of this material will not just come from the results of specific analyses, but will require broad archaeological and intellectual engagement with an intriguing problem.

Back to the Neolithic and Bronze Age – some possible interpretative themes

The original interpretative perspectives on the 2007 excavation clearly lacked a more integrated contextual emphasis. Nevertheless, some of the evidence and observations which informed those initial views remains directly relevant to re-focusing interpretative treatments of the much enhanced evidence base which is now available. In general terms, the explicit emphasis on linking the understanding of Later Neolithic and Bronze Age features to wider understanding and knowledge of cultural practices in that period surely is an important starting point (especially in a major confluence zone landscape where other significant Neolithic and Bronze Age monuments have been discovered in the last 10 years).

Nature, culture and transformation

The re-emphasis on the explicit linkage of the Ribbon to the natural landscape and the processes acting in that landscape has immediate resonances in this respect. The managed inter-play of cultural and natural elements is a widely recognised and evidenced element of Neolithic/Bronze Age cultural activity and representation. In particular, the

association of water and stone, and the cultural emulation of natural water related features, has been directly suggested as one key representative aspect of Neolithic monumental symbolism associated with ideas of transformation and the relationship between the living and dead (see, for example, Harding 1997 or Fowler and Cummings 2003). Likewise, the apparently deliberate manipulation of colour contrasts in monumental structures, and, as part of that, the frequently noted use of quartz in a range of structural and depositional Neolithic contexts, has been extensively recognised and discussed (see, for example, Bradley 1998, 104; 137; Darvill 2002; Darvill 2005).

The Rotherwas Ribbon, positioned and embedded within its local natural environment, presents some obvious possible linkages with these sorts of patterns. The creation of the Ribbon appears to involve the collection and deliberate placement of quartz and other natural stone from the immediate locality to make an artificial surface which nevertheless embeds natural materials within it. In addition, the placement of the surface within a down-slope channel/hollow (of whatever origin) must necessarily subject the feature to a degree of water flow and associated natural depositional processes. Could it be that, in some circumstances at least, the quartz rich surface was *intended* to have water running over it, was *intended* to directly relate to and/or link with natural water course features in the immediate environment, and was *intended* to be visually and physically transformed (and perhaps progressively buried/concealed) by the action of water? Likewise, the association with burning (see particularly the evidence of the 2007 excavation, and the incorporation of burnt stone in the surface), and the deposition of cultural materials (which included human bone from the 2007 excavation), could certainly be seen as powerful additional elements linked to a core idea of transformation (and, of course, those aspects of activity are again directly paralleled on many Neolithic/Early Bronze Age sites).

It may be possible to pursue this frame of reference in ways which precisely and distinctively relate to specific natural phenomena from the immediate local environment. One interesting pattern which, coincidentally or otherwise, was observed in Trenches 3 and 5, was the presence of per-glacial stripes in the natural immediately underlying the stone surfaces in those trenches. Curiously, the precise positioning and disposition of the respective surfaces appeared to respect, reference and visually add to these natural effects. To take the Trench 3 example, the stone surface sharply contrasted with the natural red clay which formed the exposed base of the hollow to the west, and interfaced to the east with the very different mixed gravel natural which underlay the surface, and formed an additional exposed stripe in the clay base of the hollow on that eastern side. Could there be an answer here to why the stone surface does not fully occupy the hollow? Perhaps it is precisely because it is the whole width of the hollow which is really the 'surface', inclusive of the exposed differences in the natural and the additional distinction with the culturally added or enhanced mixed stone/quartz rich stripe?

Rotherwas: a special landscape?

The emphasis on natural as well as cultural phenomena perhaps also helps to identify another pattern which may be significant in contextualising prehistoric cultural activity in

this river confluence zone area: although now masked and transformed by modern development, the Rotherwas locality is a highly distinctive landscape combining a range of unusual features and attributes.

The ‘was’ element of the Rotherwas place-name is uncommon (other examples are Buildwas in Shropshire and Alrewas in Staffordshire), and derives from the Old English suffix ‘waese’ referring to a particular kind of occasionally watery area. The phenomenon and the place naming that follows it seems to refer to a specific pattern of very occasional but dramatic flooding where the water rises and then disappears unusually rapidly (and the palaeoenvironmental work on the adjacent Futures appears to bear this out for the earlier prehistoric to Roman context). Similarly, Dinedor Hill is an unusual and visually striking land-form, with matching rounded summits symmetrically opposed to the east and the west of a low intervening ridge. As the geological analysis in this document has indicated, the pattern of the superficial geology hereabouts is also complex, with contrasting patterns of fluvio-glacially derived gravel and clay deposits (sometimes additionally modified by periglacial action) across the landscape. In an early prehistoric landscape which had not been subject to a further 4000 years of alluvial and colluvial accumulation and masking, those varied geological patterns and the visual patterns they created (especially where the superficial geology was directly exposed) would potentially have been a much more tangible and distinctive component of the local environment

The presence of a locally unusual linear landscape feature, perhaps especially if associated with seasonally intermittent water flow, could certainly have contributed to that sense of special place. As indicated by the geophysics, the ‘Ribbon corridor’ does occupy a distinctive landscape position which not only runs across the mid-valley slope zone to connect the flood plain with the steep slope of Dinedor Hill, but also aligns closely on the mid-point of the Dinedor Hill ridge. That apparent significance may very well have been enhanced by the exposure of peri-glacial patterns within the base of the channels and hollows broadly following this alignment, so further encouraging the modification of such features to exacerbate those particular valued attributes.

Here, perhaps, is a special zone in a special landscape with particular qualities which made it appropriate for Neolithic/Bronze Age cultural activities where nature and culture are juxtaposed, and where transformations, including that from life to death, could be played out. If that all sounds highly speculative, it is worth remembering that, even leaving the Ribbon entirely out of the explanatory equation, the archaeological evidence from nearby sites such as Bradbury Lines (including a rare pond barrow with Middle Bronze Age dates for the burnt central platform and Middle Neolithic pottery from the fill) and Rotherwas Futures already unequivocally demonstrates that this *is* a locality where special and unusual Neolithic and Bronze Age activity was occurring. So Rotherwas certainly was a special place in prehistory, and it is by no means unreasonable to begin to consider what made it so, and to seek to situate emerging archaeological evidence within that context.

Long term significance

The apparent long term (or at least repeated) use of the overall Ribbon related alignment, and particularly the incidence of later ditches following that alignment, was one of the issues which emerged from the 2007 excavation: why does this continuity occur? The answers to that question need not be complicated, and the probable up-slope presence of the later Roman (?) settlement provides an evident context for these features. One explanation would simply be that the later boundaries pick up on the micro-topography created by the earlier linear hollow/channel features.

It is however worth suggesting that this if this particular alignment has significant cultural importance in earlier prehistory, then that may well inform its survival within later settlement patterns. The evidence from Trench 5 – and the adjoining Futures site – does clearly indicate that significant cultural activity was going on hereabouts into the later Bronze Age. The nature of that activity, and what the ‘burnt mounds’ really represent in this location, is, in fact, no more clearly characterised than the activity associated with the Rotherwas Ribbon. Maybe, in overall terms, it is not a coincidence that this zone remains a significant settlement focus into the later prehistoric and Roman periods, and the placement of the Roman site may actually have a direct relationship to much earlier traditions and cultural memories which were associated with this locality.

Grasping the Ribbon

Opening these kinds of interpretative frameworks may seem premature in a document of this kind. However, the simple fact appears to be that the Rotherwas archaeological sequence is unusual and not easily explicable through reference to immediate parallels in the wider archaeological record. That, quite simply, makes it difficult to understand, but it also amplifies the potential significance of the present investigation. Engaging with this kind of archaeological problem perhaps does involve an intellectual step back at the macro level as well as a suitably rigorous investigative approach at the micro one.

One issue which the Rotherwas Ribbon ‘problem’ does raise is the extent to which our own investigative categories and cultural perceptions can tend to obscure more sophisticated recognition of the nature of earlier prehistoric cultural practice in areas like Rotherwas. On the one hand, a narrow emphasis on ‘scientific’ definitions of the difference between cultural and natural phenomena - and therefore the implied archaeological value of the different deposits so categorised - may ultimately mask rather than unveil the recognition of what was culturally important for Neolithic and Bronze people. And on the other, Rotherwas perhaps also demonstrates the simple intellectual challenge of analytically engaging with archaeological sequences which do not seem to resemble those we already have.

The danger is that we end up putting into the ‘too difficult box’ the very variation which is actually a key component in better understanding the cultural meaning and references of the wider body of ‘conventional’ Neolithic and Bronze Age evidence. That is an important observation to bear in mind when engaging with the results of this project.

5.2 Proposed Post Excavation Work

Objectives

- As far as possible, establish an absolute dating framework for the stone surface deposits potentially relating to earlier prehistoric phases of activity;
- As far as possible, establish absolute dates for the formation of the hollows/channels to which those surfaces relate;
- Where possible, undertake a selective dating programme of the later ditches associated with the hollows/surfaces so these can be more firmly contextualised within the deposit sequence, and their potential inter-relationship more closely established;
- Extend, as appropriate within the identified potential, the palaeoenvironmental and geoarchaeological analyses to support further definition of the nature and associations of the surfaces and deposit sequences potentially relating to earlier prehistoric phases of activity (principally Trenches 3, 4 and 5), and to the origin of the hollow/channel features with which those phases of activity are associated;
- Complete the artefact descriptions and analyses to support the wider contextual analysis of the observed sequences.

Constraints

- Given the Project Aims, it is not proposed to take forward more detailed analysis or dating of the features in Trenches 1 and 2 which have been identified at the Assessment Stage as Roman or later date.

5.2.1 Scientific Dating

OSL dating note

It did not prove possible in the timeframe available during the present assessment exercise to undertake initial 'test' dating of selected OSL samples. In principle, and subject to funding availability, the proposed processing of OSL would there be a two stage approach, commencing with targeted processing of 3 samples initially (in part to test the viability of the procedure in terms of these deposits), with the potential to complete the suggested extended sample processing programme subject to the success of that initial test dating phase.

Trench 1 – Central Area

Potential

- In addition to Roman pottery, numerous bone fragments were recovered from surface and fill contexts 2506 (36 fragments), 2511 (12 fragments) and 2529 (12 fragments), and would potentially permit more refined C14 dating of this sequence;
- Charcoal was recovered from ditch 2531, and this could be subject to C14 dating. This will not only help confirm the date of the lower metalled surface, but perhaps even more importantly, it could help clarify whether the ditch is the same as that seen in the other four trenches.
- Three OSL samples (Numbers 05, 06 and 07) were taken from this trench. The first was located underneath the base surface (2517), the second was taken from the upper surface (2511) and the third from the associated ditch (2531). Analysis of these samples would only be undertaken in order to confirm the results of the pottery analysis.

Proposed Further Analysis

All the archaeological features area are demonstrated to be of Roman or later date, and refined dating will not significantly inform the core research questions which are associated with the earlier prehistoric phases.

No further dating analysis is proposed.

Trench 1 – Eastern Area

- The dark fill layer included a large quantity of bone and Roman pottery (2503 [65 sherds]).
- Roman Pottery was also recovered from the base fill of the associated ditch (2527 [7 sherds]). Charcoal was recovered from the lower fill of the ditch
- Numerous bone fragments were recovered from the undated ‘Ribbon like’ metalled surface 2532, from within the surface itself (2532 [14 pieces]) and from under it (2518 [6 pieces]). C14 dating of The 2518 samples will potentially establish a *terminus post quem* for the surface.
- An OSL sample was taken from underneath the metalled surface.

Proposed Further Analysis

The lower surface is ‘Ribbon like’ in some characteristics, and although it is stratigraphically sealed by Roman associated horizon, and the bone material resembles that from the Roman contexts, it is nevertheless felt appropriate to proceed with independent scientific dating of this feature.

It is therefore proposed to proceed with the OSL dating in the first instance, and to consider C14 dating of context 2518 depending on the OSL results (which are subject to the viability of the OSL sample). The OSL dating will also more broadly support understanding of the chronological context of this hollow/channel feature with reference to other hollows/channels in the other trenches.

Trench 2

- No Roman pottery was recovered from the lower metalled surface (3017) or from beneath it (3021), and the only finds from the surface were a small number of flints.
- Numerous bone fragments were recovered from this trench, the most important being from the layer between the two metalled surfaces (3015). This is important due to the lack of pottery and C14 dating could provide a *terminus post quem* for the upper surface and a *terminus anti quem* for the lower.
- Three OSL samples were taken from underneath the lower metalled surface (3021), from the lower metalled surface itself (3017) and from above the upper metalled surface (3005). This is the first instance whereby a lack of other dating evidence means that OSL dating is the only way to date the construction period of the lower metalled surface.
- No charcoal samples were taken from this trench.

Proposed Further Analysis

Although overlain by Roman pottery associated contexts, the lower surface is undated, and may be potentially associated with earlier phases of activity along the Ribbon corridor, and it is felt appropriate to proceed with independent dating of this feature. It is therefore suggested that samples 3021 and 3017 should be processed.

It is not proposed to proceed with potential C14 dating of the bone samples from context 3015.

Trench 3

Potential

- 75 Bone fragments were recovered from 9 contexts. In particular, 10 fragments of animal bone were found on the ‘ribbon’ surface itself (3514) and could be subject

to C14 dating. The animal bone found in the lower fills of the ‘enclosure’ ditch (3507) might also be subject to potential C14 dating.

- Five OSL samples (Numbers 10, 11, 12, 13 and 25) were taken. With respect to the Ribbon, the first (25) is located beneath the ribbon (context 3553 – potentially providing a *terminus post quem*). The second (10) was taken through the Ribbon itself and the third (11) was taken from context 3445 that immediately overlies the Ribbon.
- No specific charcoal samples were taken from this trench.

Proposed Further Analysis

Given the potential significance of Trench 3 and the Ribbon deposit, it is proposed to proceed with processing of the OSL samples which bracket the Ribbon feature (Numbers 25, 10 and 11).

It is not felt to be appropriate to proceed with potential C14 dating of the bone from the Ribbon surface. This is no more contextually secure than the charcoal samples processed from the 2007 Ribbon surface, and its poor condition may in any case preclude its effective use for dating purposes (although it has not been specifically assessed for this purpose).

Trench 4

Potential

- 5 bone fragments were recovered from two contexts 4002 and 4011. C14 dating is not necessary for 4002 (given the large quantity of diagnostic flint from that horizon). However, dating of 4011 (one of the stony fills at the base of the channel) is important in contextualising that phase of the channel sequence. However, it remains to be seen if the single small bone fragment concerned will be viable for C14 dating purposes.
- Seven OSL samples (Numbers 14, 15, 16, 17, 18, 19 and 20) were taken from two areas; samples 14, 15, 16 and 17 were taken from the west end of trench, the remainder from the centre. From the first group, although all four dates would be of interest, sample 15 is from the layer associated with the flint scatter which may confirm the date of the ground surface onto which the flint was deposited. Of the remaining three samples 18 and 19 are of particular interest. The first is from context 4032, through which the main depression was ‘cut’ and the second is from the last but one fill of the depression. These samples may therefore date the formation of the depression and when it finally silted up.
- Charcoal was recovered from 4030, a cleaning layer off the top of the hardstanding 4028. This is of note as it may establish a *terminus ante quem* for the

surface on which the large flint assemblage originated, although its contextual relevance in that sense is not clear.

Proposed Further Analysis

Given the potential significance of Trench 4 to the understanding of the wider deposit sequence along the Ribbon corridor, it is proposed to proceed with processing of OSL sample 15 (with which the flint assemblage is associated, and which forms an important reference point in the sequence), and samples 18, 19 and 20 (which bracket the principal channel sequence in the central part of the depression).

In addition, it is proposed to proceed with C14 dating of context 4011 (subject to the establishment of the viability of that sample) since this potentially supports the OSL dating sequence.

Trench 5

Potential

- 70 bone fragments were recovered from this trench. Bone from two contexts (4507 and 4510 [same as 4523]) could provide useful dates via C14 dating. The first, 4507 (19 fragments) immediately underlies the upper ‘burnt mound’ surface and overlies the middle surface, thus providing a *terminus post quem* and *terminus ante quem* respectively. The second context (4510, 32 fragments) formed the surface of the natural gravel (or base of 4532). Dating this bone therefore may provide a date that pre-dates this surface.
- Three OSL samples (Numbers 22, 23 and 24) were taken from this trench. One was from the natural underlying the lowest metallated surface, one from the horizon between the lower and mid surfaces and one from the ‘burnt mound’ surface.
- Charcoal was recovered from context 4535, the fill of a cut directly under the ‘burnt mound’ surface and associated with it, and potentially provides a *terminus post quem* for the burnt mound.

Proposed Further Analysis

The sequence in Trench 5 is important in chronologically contextualising the ‘Ribbon like’ lower surface with respect to the overlying ‘burnt mound feature’. It is therefore proposed to proceed with C14 dating of the bone from context 4507 (subject to the viability of that material for this purpose), and the charcoal from context 4535 underlying the burnt mound.

It is also proposed to proceed with the processing of OSL sample 23 which lies between the lower and middle surfaces and potentially establishes an important chronological reference point for both these features

5.2.2 Geoarchaeology

Following on from the data analysis and analytical potential which has been discussed in the geoarchaeology Specialist Report, the following further work is proposed:

General Recommendations

- The creation of a criteria matrix (as discussed in the conclusions to the geoarchaeological assessment) is a clear way of objectively analysing and evaluating the sets of data acquired via geoarchaeological, palaeo-environmental and archaeological interrogation.
- Full records have been made but these need fully integrating with the archaeological and contextual record. In addition the photographic record should be made of the vertical stones, and stone orientation in the stone-dominated layer as preserved in monolith 181, as these are not periglacially arranged but are probably a result of human or animal trampling when wet.

Clast Analysis

Although the existing analysis is judged to be of significant value in itself, further analysis to strengthen the conclusions is proposed to include:

- Lithological and shape analysis of further samples from trench 1, 3 and 5. (This is important in terms of relating the stone-dominated layers to the Pleistocene deposits in the area)
- Lithological and shape analysis of the finer gravel fractions (Time did not permit the analysis of the finer gravels obtained from the trenches. Some samples have too few clasts to be of interest, further work on the trench 4 and 5 samples would be worthwhile)
- Sampling and analysis of the lithological and shape characteristics of surrounding remnants of the Wye Valley Formation to assess local variability (there is potentially a lot of variation in the Wye Valley Formation that hasn't been documented. Extra data would allow us to be more confident in tracing the source of the gravels)
- Sampling of lithologies of Dinedor (the source of the sandstones that dominate trenches 1, 2 and possibly 3 are not yet confirmed)

Final Report Preparation/Publication

- The full profile of the Dinedor slope profile should be drawn locating the trenches, presence of concentrations of stone-dominated layers and thickness of the colluvium. This should be undertaken by Hereford Archaeology with information from M. Allen

- Final completion of the contextual geoarchaeological research and reporting, including editing specialist contributions to create a single unified geoarchaeological section addressing the research aims above and given in Appendix 2

5.2.3 Environmental Remains

Following on from the data analysis and analytical potential which has been discussed in the environmental remains Specialist Report, the following further work is proposed:

Potential

Further processing of samples has the potential to clarify and test statements made on the variation of ecofactual and artefactual remains seen in samples from the south to the north of the site as a result of this assessment. However, the focus would be on Trenches 3, 4 and 5 where prehistoric activity is more prevalent. This would allow the characterisation of the compact stone layers to be strengthened and allow assessment of the relationship between these and other features in the Ribbon corridor. Although hand-collection of artefacts has already demonstrated differences between trenches, full sorting of residues including recording of weight (g) per 10 litre sub-sample will allow a more precise comparison of deposit make-up and will allow assessment, for example, of variation within extensive layers.

The following of the original objectives can be addressed:

- To further test the combined relationship, character and formation process of the Ribbon surface, intervening silt/other horizons, and the Ribbon construction cut (in so far as these components are collectively present along the monument as a whole)
- To assess the relationship of the Rotherwas Ribbon to other archaeological features in its vicinity including associated pits, the known earlier ditch, and the later ditches, and to interrogate the reason for the coincidence of these features in one corridor

Constraints

- No recommendations are made for further work on the palynological or macrofossil remains because of the low concentration and preferential preservation seen within the assessed samples.

Process

The assessment has used both recording of remains by weight and estimates of abundance. Where weights were recorded these are considered to have been useful in comparing assemblages, and as determining the nature of taphonomic processes involved in the formation of these deposits is important, recording of weights is recommended for

further work. For compact stone layers, recording this information separately for each bucket would also allow assessment of spatial variability in composition.

For compact stone layers, processing of 10 litre buckets not yet fractionated (up to 100 litres) is recommended for the contexts listed below. For other features, processing of the remainder of the following samples is recommended:

- One or two contexts per trench for compact stone surfaces for Trenches 3, 4 and 5: 3545 (Trench 3), 4028 (Trench 4) and 4514 (Trench 5)
- Three contexts directly above or below the 'Ribbon'; contexts 3513, 3546 and 4008
- Ditch contexts 3517, 3524, 3538 and 4019; layer 4531; pit/burnt mound deposits 4506, 4518 and 4535

The report will take into account conclusions made in the geoarchaeological assessment, particularly to aid interpretation of taphonomic processes. Information on samples included in the assessment but not the above list will also be addressed in the final report where relevant.

5.2.4 Prehistoric Pottery

Following on from the data analysis which has been discussed in the prehistoric pottery Specialist Report, the following further work is proposed:

Potential

The significance of this group lies in the associated features, which are either directly interpreted as burnt mound deposits or are stratigraphically related to these.

Recommendation

- These sherds require further fabric analysis and comparisons with the Worcestershire fabric series, but very little additional work beyond a search for local and regional parallels, which will put the pottery into a regional context;
- In addition, undertake analysis of the two pottery sherds from within the 'ribbon' surface (context 3514) which was omitted from the present assessment report stage.
- No illustrations will be required for these sherds. Fabric analysis and search for parallels will require 0.5 day.

5.2.5 Roman Pottery

Following on from the data analysis which has been discussed in the Roman pottery Specialist Report, the following further work is proposed:

Potential

- Only the Roman pottery from Trench 1 justifies further analysis. The pottery provides a chronological sequence for the deposits investigated.
- More detailed analysis of the fabrics, specifically the Severn Valley ware, will allow for comparison with other Herefordshire sites, in particular the other sites excavated along the Rotherwas Ribbon (WHEAS 2009, 2010).

Recommendation

- It is proposed, that in the light of the potential significance of the assemblage as part of the wider Access Road corridor, that the further analysis is undertaken (notwithstanding the general proposal to limit the further analysis work to pre-Roman contexts)
- It is estimated that c 15 sherds will require drawing, to illustrate the dating evidence.
- A publication text will be prepared

5.2.6 Struck Lithics

Following on from the data analysis and analytical potential which has been discussed in the Roman pottery Specialist Report, the following further work is proposed:

- A publication text of c 2000 words with 1-2 tables should be prepared using the assessment text as the basis of the document, but expanding the discussion to include other sites in the region. The scrapers from this excavation should be included in the scraper analysis proposed for those from the Bypass Excavation as the combined assemblage is not paralleled in the region.
- The illustration of seven retouched tools will complement the report and minimise the need for descriptive text. A provisional list comprises all three scrapers, the petit tranchet arrowhead, the wedge-shaped flake, the backed knife and a piercer.

Additional Note

- A metrical and technological attribute analysis is not recommended as it will not clarify the date of the flints from context 4002. Similarly, a refitting exercise on the flint from 4002 is not recommended as it is unlikely to be successful and it will not further elucidate reduction techniques.

5.2.7 Animal Bone

Following on from the data analysis and analytical potential which has been discussed in the Roman pottery Specialist Report, the following further work is proposed:

Potential

The assemblage is too small and too poorly preserved to warrant further study.

Recommendations

As all the identifiable animal bone fragments are listed in the catalogue forming part of this report it is recommended that no further analysis is required.

6. REFERENCES

- Bamford, H. 1985 Briar Hill: excavation 1974-1978. Northampton, Northampton Development Corporation.
- Bapty I, 2010. Project Design to English Heritage for Further Investigation of the Rotherwas Ribbon, Stage 2: Additional Fieldwork, Version 3, Variation to EH PNUM 5463.
- Bapty, I and Atkinson, C 2011 Further investigation of the Rotherwas Ribbon Stage 1a: LIDAR Survey, Herefordshire Archaeology Report for English Heritage
- Bapty, I, and Williams, D N 2011 Further investigation of the Rotherwas Ribbon: 2010 excavation assessment report, Herefordshire Archaeology Report 231
- Barber, K E, 1976 History of vegetation, in S Chapman (ed) *Methods in plant ecology*, Oxford: Blackwell Scientific Publications, 49-52
- Bennett, K D, 1994 Annotated catalogue of pollen and pteridophyte spore types of the British Isles, unpublished report, Department of Plant Sciences, University of Cambridge
- BGS. 1989 British Geological Survey. Hereford, England and Wales Sheet 181, Solid and Drift Edition 1:50,000 Series.
- Boucher A. 2009 Rotherwas Ribbon, Hereford: Geophysical Surveys – A Report by Archaeological Investigations Limited.
- Bradley, P. 1999 Worked flint. Excavations at Barrow Hills, Radley, Oxfordshire. Volume 1: The Neolithic and Bronze Age monument complex. A. Barclay and C. Halpin. Oxford, Oxford Archaeology 211-227.
- Bradley, R. 1998 *The Significance of Monuments. On the shaping of human experience in Neolithic and Bronze Age Europe*. Routledge.
- Bridgland, D.R. 1986. Discussions of procedures and recommendations. In D.R. Bridgland (ed.), *Clast lithological analysis*. Cambridge: Quaternary Research Association Technical Guide 3
- Butler, C. 2005, Prehistoric flintwork. Stroud, Tempus.
- Cappers, T R J, Bekker, R M, and Jans, J E A, 2006 *Digitale Zadenatlas van Nederland: Digital seed atlas of the Netherlands*, Groningen Archaeological Studies, 4, Barkhuis Publishing and Groningen University Library: Groningen
- Clapham, A R, Tutin, T G and Moore D M, 1989 *Flora of the British Isles*, (3rd edition), Cambridge University Press

Darvill, T. 2002, *White on Blonde: Quartz, Pebbles and the Use of Quartz at Neolithic Monuments in the Isle Of Man and Beyond*, in *Colouring the Past: The Significance of Colour in Archaeological Research*, A. Jones and G. MacGregor (ed), Berg, Oxford

Darvill, T. 2005 *Prehistoric Britain* (2nd edn).

English Heritage 2002 *Environmental Archaeology: a guide to the theory and practice of methods, from sampling and recovery to post-excavation*, Centre for Archaeology. Guidelines

Fowler, C and Cummings, V. 2003. *Places of Transformation: Building Monuments From Water and Stone in the Neolithic of the Irish Sea*, *Journal of the Royal Anthropological Institute*, 9, 1-20

French, H.M and Williams, P. 2007. *The Periglacial Environment*. Chichester: John Wiley & Sons

Gale, S.J. and Hoare P.G. 1991. *Quaternary Sediments; petrographic methods for the study of unlithified rocks*. London: Belhaven Press

Grant-Smith, E, 2000 *Sampling and identifying allergenic pollens and molds: An illustrated identification manual for air samplers*, San Antonio, Texas: Blewstone Press
IfA, 2008 *Standard and guidance for archaeological excavation*, Institute for Archaeologists

Harding, J. 1997 *Interpreting the Neolithic: the monuments of North Yorkshire*. Oxford *Journal of Archaeology* 16, 279-95.

Healy, F. 1988 *The Anglo-Saxon cemetery at Spong Hill, North Elmham. Part VI: Occupation in the seventh to second millennia BC*. Gressenhall, Norfolk Archaeological Unit.

Hodgson, J.M. 1976. *Soil Survey Field Handbook*. Harpenden: Soil Survey Technical Monograph No. 5

Hey, R.W. 1991. *Pleistocene gravels in the lower Wye valley*. *Geological Journal* 26 (2), 123-136

Kirk, P M, Cannon, P F, Minter D W and Stalpers J A, 2008 *Dictionary of the fungi* 10th Edition, Wallingford: CABI Publishing

Lamdin-Whymark, H. forthcoming *Intentional Breakage in the British Neolithic. Lithic Technology, Manufacture and Replication Studies Reconsidered*. C. J. Bond. *British Archaeological Reports, International Series 000*.

Maddy, D. 1999. The Midlands, 28-44. In D.Q.A. Bowen, A revised correlation of the Quaternary Deposits in the British Isles. Geological Society of London Special Report No. 23

Moore, P D, Webb, J A and Collinson, M E 1991 Pollen analysis, (2nd edition), Blackwell Scientific Publications, Oxford

Martingell, H., et al. 1988 The illustration of lithic artefacts: a guide to drawing stone tools for specialist reports. Cardiff, Association of Archaeological Illustrators & Surveyors; Lithic Studies Society.

Sumbler, M. G. 1996 British regional geology: London and the Thames Valley. London, HMSO for the British Geological Survey.

SSEW. 1983 Soil Survey of England and Wales. Soils of England and Wales, Sheet 3, Midlands and Western England.

Stace, C, 1997 New Flora of the British Isles, Cambridge University Press, (2nd Edition)

Sworn, S. Jackson, R. and Woodiwas, S. 2009. Rotherwas Access Road, Herefordshire: Preliminary Structural Description and Assessment of the Rotherwas 'Ribbon' and closely associated activity. Unpubl. Worcestershire Historic Environment and Archaeology Service Report (Project P2735), version 1, dated 20 October 2009

Wilkinson, K. 2009. Geoarchaeology (section 4.10). In S. Sworn, R. Jackson and S,

Woodiwas, Rotherwas Access Road, Herefordshire: Preliminary structural description and assessment of the Rotherwas 'Ribbon' and closely associated activity. Unpubl. Worcestershire Historic Environment and Archaeology Service Report (Project P2735), version 1, dated 20 October 2009

APPENDIX 1: STRATIGRAPHIC MATRICES AND FINDS CATALOGUE

It is to be noted that stratigraphic descriptions are the preliminary result of on-site interpretation and not specialist interpretation.

Section Drawings as scanned from the primary record drawings, and are included in that form for additional reference

Trench 1

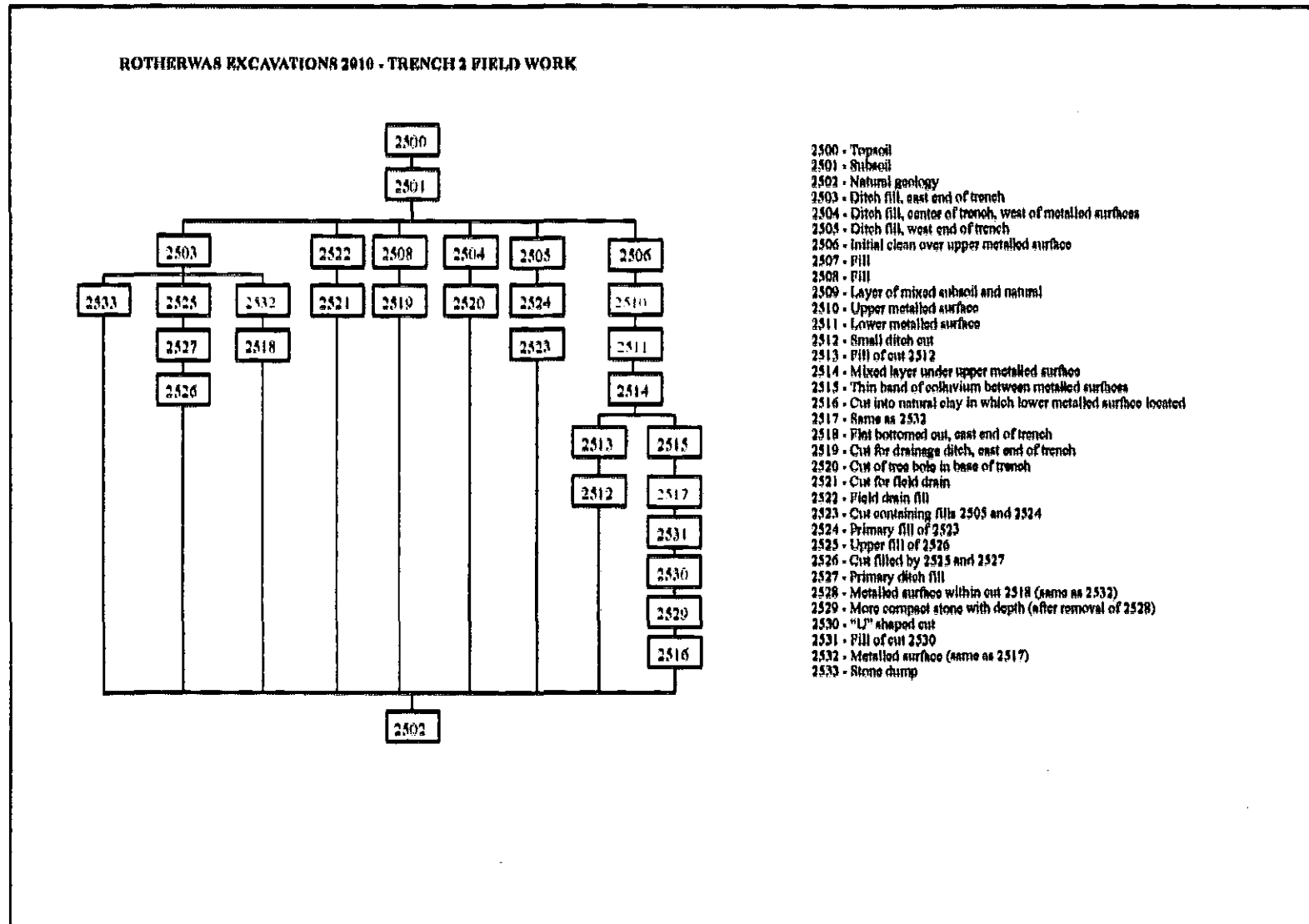

Trench 2

ROTHERWAS EXCAVATIONS 2010 - TRENCH 2 FIELD WORK

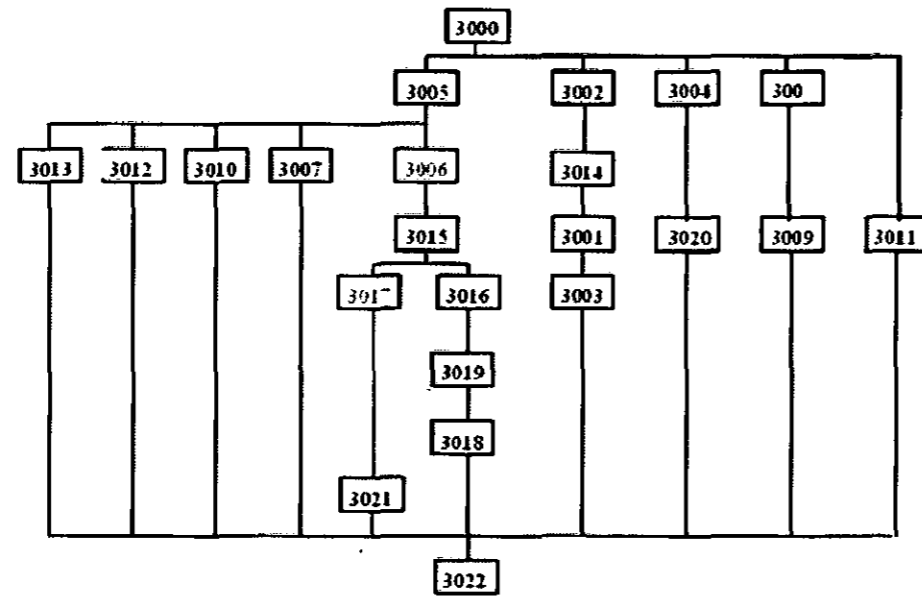

- 3000 - Topsoil.
- 3001 - Cut, west end of trench.
- 3002 - Fill of 3001 (suspected Roman pottery).
- 3003 - Colluvial deposit.
- 3004 - Layer of clay and stone.
- 3005 - Colluvial deposit.
- 3006 - Compact stone surface.
- 3007 - Layer of clay and stone.
- 3008 - Pit fill.
- 3009 - Pit cut.
- 3010 - Layer of silty clay.
- 3011 - Cut for land drain.
- 3012 - Land drain fill.
- 3013 - Natural clay subsoil.
- 3014 - Primary fill of 3001.
- 3015 - Colluvial deposit filling all low lying features.
- 3016 - Lense of sandy silt in base of cut 3018.
- 3017 - Metalled surface.
- 3018 - "U" shaped ditch cutting compact stone surface 3006.
- 3019 - Primary fill of 3018.
- 3020 - Cut for land drain 3004.

South Facing Section

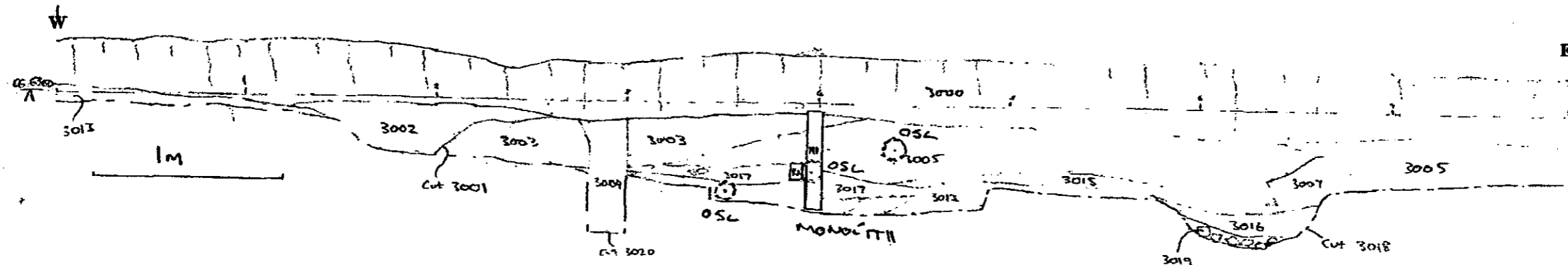

Trench 3

ROTHERWAS EXCAVATIONS 2010 - TRENCH 3 FIELD WORK

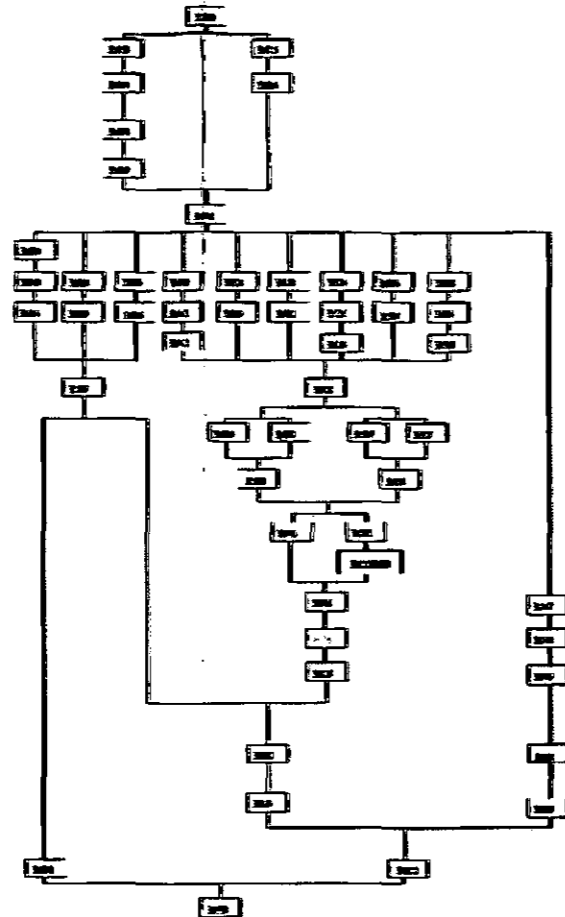

- 3500 - Topsoil
- 3501 - Subsoil
- 3502 - Natural
- 3503 - Land drain fill
- 3504 - Land drain cut
- 3505 - Secondary ditch fill (cut 3507)
- 3506 - Primary ditch fill (cut 3507)
- 3507 - Ditch cut
- 3508 - Modern ditch fill (cut 3509)
- 3509 - Modern ditch cut
- 3510 - Upper fill of ditch 3512
- 3511 - Lower fill of ditch 3512
- 3512 - Ditch cut
- 3513 - Layer of sand and silt (colluvium) same as 3522)
- 3514 - Stone surface (metalled)
- 3515 - Fill of land drain 3516
- 3516 - Land drain cut
- 3517 - Fill of linear drain 3518
- 3518 - Linear ditch cut
- 3519 - Fill of linear ditch 3520
- 3520 - Linear ditch cut
- 3521 - Redeposited natural
- 3522 - Colluvium, same as 3513
- 3523 - Cut for "ribbon"
- 3524 - Silty fill of ditch 3512 (same as 3510?)
- 3525 - Secondary fill of 3512 (same as 3510?)
- 3526 - Same as 3524?
- 3527 - Fill of ditch 3518
- 3528 - Same as 3525
- 3529 - Primary fill of 3512

- 3530 - Fill of cut 3507
- 3531 - Natural gravel
- 3532 - Fill of linear ditch 3520
- 3533 - Upper fill of 3512
- 3534 - Fill of linear 3512
- 3535 - Primary fill of 3512
- 3536 - Secondary fill of 3512
- 3537 - Primary fill of 3512
- 3538 - Secondary fill of ditch cut 3507
- 3539 - Primary fill of ditch cut 3507
- 3540 - Upper fill of 3512
- 3541 - Fill of 3512
- 3542 - Primary fill of 3512
- 3543 - Secondary fill of ditch 3507
- 3544 - Primary ditch fill of 3507
- 3545 - Thin sand deposit over metalled surface 3514
- 3546 - Redeposited natural
- 3547 - Shallow silt band in top of ditch 3549
- 3548 - Fill of cut 3549
- 3549 - Possible ditch
- 3550 - Natural underlying "ribbon"
- 3551 - Natural gravels (possible cryoturbation)
- 3552 - Natural gravels
- 3553 - Natural clay (gleying)
- 3554 - Natural clay

OSL
 T1 NO
 T2 3017 (NO OSL NO ISSUED ON SITE)
 T3 3513 - 12
 3514 - 10
 3545 - 11
 T4 NO
 T5 4507 - 24
 4532 - 23

South Facing Section

Site Drawing Sheet				Historic Environment & Archaeology Service AS34	
No. Date	Project number	Site name	Scale	Drawing number	
1/10	1	R. ROTHERWAS	1:20	363	
Prepared by	Date	Checked by	Issued	Quantity	Notes
TEC	21/1/10			Quantity sheet 14 of 14	Sheet 3 of 14
APPROVED 4/3/10, TEC + 8/3/10, TEC				Reproduction 5/1 THIS PLAN	

SOLUTION 362 NO. 120 21/1/10 SOUTH FACING SECTION

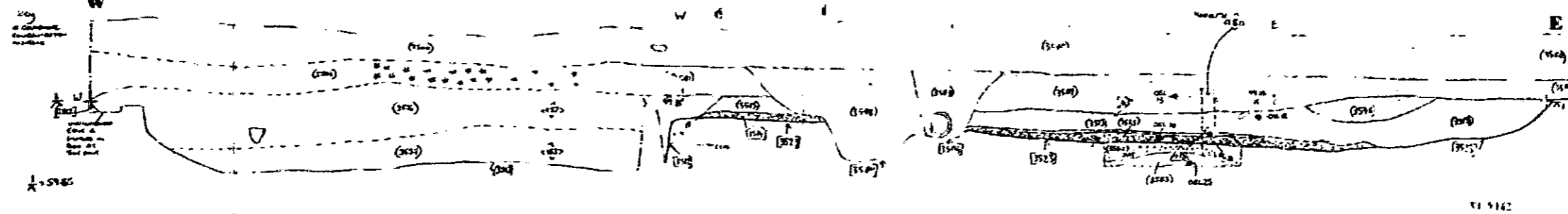

Trench 4

ROTHERWAS EXCAVATIONS 2010 - TRENCH 4 FIELD WORK

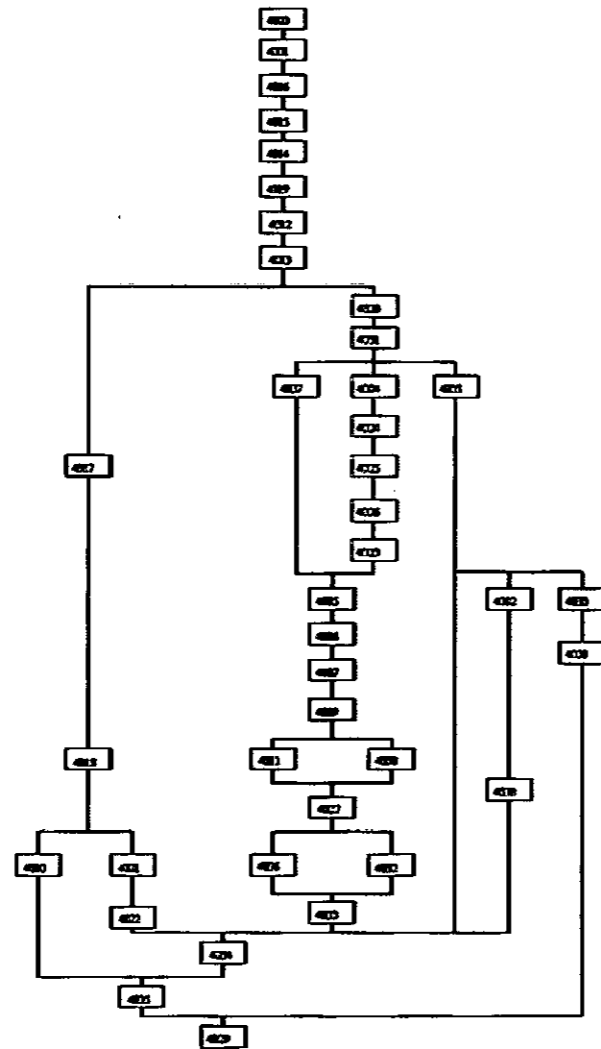

- 4000 - Topsoil
- 4001 - Subsoil
- 4002 - Colluvium
- 4003 - Interface between colluvium and alluvium
- 4004 - Same as 4003
- 4005 - Palaeochannel fill
- 4006 - Silty clay palaeochannel fill
- 4007 - Palaeochannel fill
- 4008 - Primary deposit of palaeochannel 4027
- 4009 - Palaeochannel fill
- 4010 - Silty clay layer/fill
- 4011 - Base deposit of channel 4027
- 4012 - Fill of ditch 4013
- 4013 - Linear ditch cut
- 4014 - Fill of ditch 4019
- 4015 - Fill of ditch 4019
- 4016 - Fill of ditch 4019
- 4017 - Clay sand between 4013 and 4019
- 4018 - Silty sand between 4013 and 4019
- 4019 - Ditch cut
- 4020 - Subsoil
- 4021 - Fill of ditch 4022
- 4022 - Ditch cut
- 4023 - Palaeochannel fill
- 4024 - Palaeochannel fill
- 4025 - Palaeochannel fill
- 4026 - Palaeochannel fill
- 4027 - Palaeochannel cut
- 4028 - Gravel patch
- 4029 - Natural gravel
- 4030 - Cleaning deposit
- 4031 - Gleyed subsoil
- 4032 - Channel fill
- 4033 - Channel cut
- 4034 - Natural sands and gravels
- 4035 - Natural clay
- 4036 - Channel fill
- 4037 - Upper fill of palaeochannel 4027
- 4038 - Shallow depression

Site Drawing Sheet		Historic Environment & Archaeology Service 4534			
No.	Page No.	Scale	Date	Author	Reviewer
4000	1/15	1:50	12/10	AS	AS
4001	1/15	1:50	12/10	AS	AS
4002	1/15	1:50	12/10	AS	AS
4003	1/15	1:50	12/10	AS	AS
4004	1/15	1:50	12/10	AS	AS
4005	1/15	1:50	12/10	AS	AS
4006	1/15	1:50	12/10	AS	AS
4007	1/15	1:50	12/10	AS	AS
4008	1/15	1:50	12/10	AS	AS
4009	1/15	1:50	12/10	AS	AS
4010	1/15	1:50	12/10	AS	AS
4011	1/15	1:50	12/10	AS	AS
4012	1/15	1:50	12/10	AS	AS
4013	1/15	1:50	12/10	AS	AS
4014	1/15	1:50	12/10	AS	AS
4015	1/15	1:50	12/10	AS	AS
4016	1/15	1:50	12/10	AS	AS
4017	1/15	1:50	12/10	AS	AS
4018	1/15	1:50	12/10	AS	AS
4019	1/15	1:50	12/10	AS	AS
4020	1/15	1:50	12/10	AS	AS
4021	1/15	1:50	12/10	AS	AS
4022	1/15	1:50	12/10	AS	AS
4023	1/15	1:50	12/10	AS	AS
4024	1/15	1:50	12/10	AS	AS
4025	1/15	1:50	12/10	AS	AS
4026	1/15	1:50	12/10	AS	AS
4027	1/15	1:50	12/10	AS	AS
4028	1/15	1:50	12/10	AS	AS
4029	1/15	1:50	12/10	AS	AS
4030	1/15	1:50	12/10	AS	AS
4031	1/15	1:50	12/10	AS	AS
4032	1/15	1:50	12/10	AS	AS
4033	1/15	1:50	12/10	AS	AS
4034	1/15	1:50	12/10	AS	AS
4035	1/15	1:50	12/10	AS	AS
4036	1/15	1:50	12/10	AS	AS
4037	1/15	1:50	12/10	AS	AS
4038	1/15	1:50	12/10	AS	AS

North Facing Section

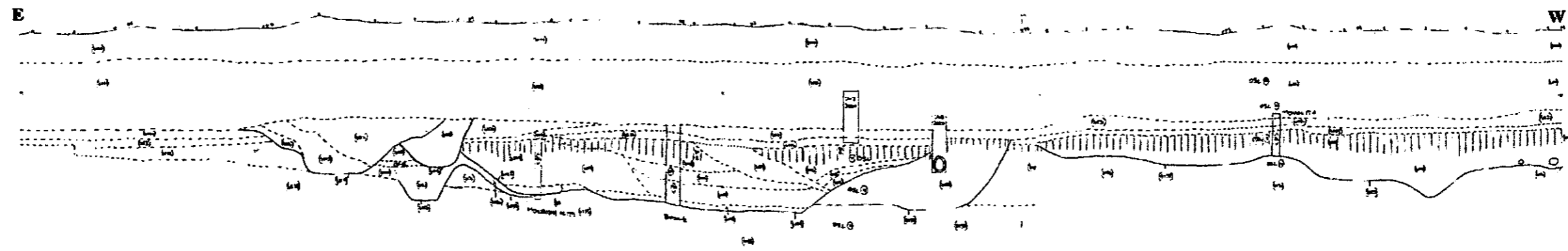

Trench 5

ROTHERWAS EXCAVATIONS 2010 - TRENCH 5 FIELD WORK

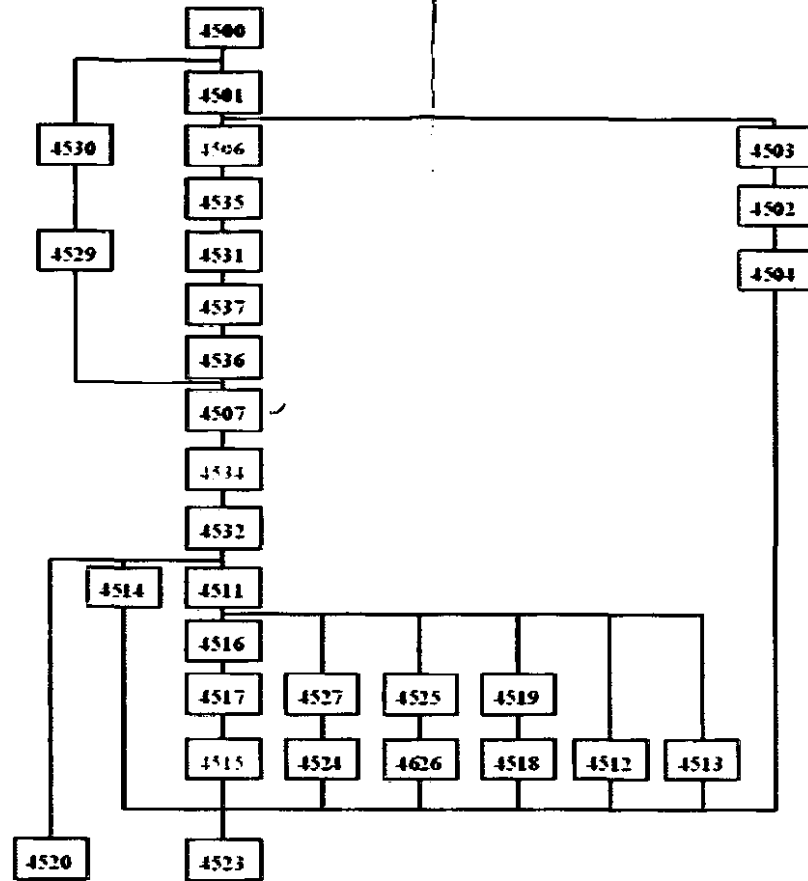

- 4500 - Topsoil
- 4501 - Subsoil
- 4502 - Gravel layer
- 4503 - Mineralised natural
- 4504 - Linear cut into natural gravel
- 4505 - Soil patch within natural gravel, later to become two separate pits.
- 4506 - Burnt mound, circular layer of compact stone
- 4507 - Buried soil
- 4508 - Thin band of colluvium
- 4509 - Natural clay, inverted as a result of cryoturbation
- 4510 - Re numbered 4523, natural gravel
- 4511 - Cobbled surface at east end of the excavated trench
- 4512 - Pit (containing possible Bronze Age pottery)
- 4513 - Pit (containing possible Bronze Age pottery)
- 4514 - Large cobble surface
- 4515 - Compact metallated surface ('ribbon')
- 4516 - Fill of cut through 'ribbon'
- 4517 - Cut through 'ribbon'
- 4518 - Pit, cuts natural
- 4519 - Fill of 4518
- 4520 - Natural gravel aligned roughly northwest-southeast (glacial gravel?)

- 4521 - Fill of tree bole cut into natural gravel
- 4522 - Tree bole
- 4523 - Alternating bands of natural clays and gravels (cryoturbation)
- 4524 - Circular cut
- 4525 - Fill of pit 4526
- 4526 - Pit cut
- 4527 - Fill of pit cut 4524 (contain pottery of suspected Bronze Age date)
- 4528 - Same as 4523
- 4529 - Pit cut east of the "burnt mound"
- 4530 - Fill of pit
- 4531 - Layer of burning and charcoal
- 4532 - Subsoil outside the line of the 'ribbon'
- 4533 - Cut in natural into which the 'ribbon' is inserted
- 4534 - Narrow compact stone band (middle surface)
- 4535 - Band of charcoal within "burnt mound" pit
- 4536 - Burnt mound pit cut
- 4537 - Thin band of charcoal "lining" pit cut 4536

Site Drawing Sheet		Historic Environment & Archaeology Service AS34	
Site Code: 2387	Project: 2317	Scale: 1:20	Drawing number: 458
Recorded by: TC	Date: 11/1/10	Checked by:	Scanned:
Description: Cross-section of section 458, Rotherwas			Sheet: +
Adjacent plans:			459 THIS PLAN 457

South Facing Section

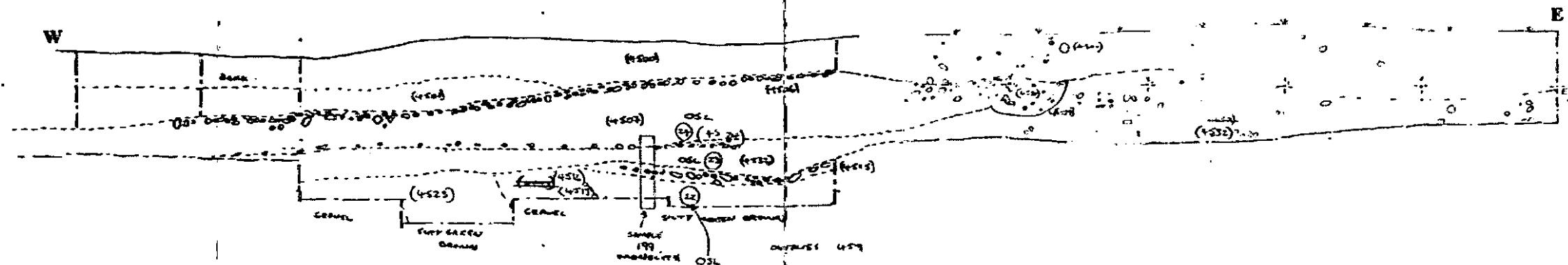

FINDS CATALOGUE**Trench 1 – Small finds**

Small find No.	Context	Type	Number	Weight
2	2515	Flint	1	4g

Trench 1 – Other

Number	Context	Type	Number	Weight
	2503	Pottery	65	678g
	2503	Bone	36	319g
	2504	Pottery	6	90g
	2504	Bone	2	3g
	2505	Pottery	97	1361g
	2505	Bone	13	430g
	2506	Pottery	10	114g
	2506	Bone	24	135g
	2508	Pottery	2	21g
	2511	Flint	1	11g
	2511	Pottery	4	117g
	2511	Bone	12	208g
	2511	Brick	1	642g
	2513	Bone	1	5g
	2513	Pottery	2	7g
	2514	Flint	1	2g
	2514	Bone	10	101g
	2514	Pottery	11	190g
	2515	Bone	7	8g
	2518	Bone	6	308g
	2518	Pottery	1	6g
	2522	Pottery	2	14g
	2524	Bone	3	28g
	2525	Bone	12	131g
	2525	Pottery	1	13g
	2527	Pottery	7	39g
	2528	Pottery	3	7g
	2529	Pottery	24	178g
	2529	Bone	12	82g
	2532	Bone	14	107g
	2533	Bone	1	33g

Trench 1 - All finds by context

	Flint	Bone	Pottery	Glass	Burnt clay	Burnt stone	Quartz	Tile	Brick
2503	-	36 (319g)	65 (678g)	-	-	-	-	-	-
2504	-	2 (3g)	6 (90g)	-	-	-	-	-	-
2505	-	13 (430g)	97 (1361)	-	-	-	-	-	-
2506	-	24 (135g)	10 (114g)	-	-	-	-	-	-
2508	-		2 (21g)	-	-	-	-	-	-
2511	1 (11g)	12 (208g)	4 (117g)	-	-	-	-	-	1 (642g)
2513	-	1 (5g)	2 (7g)	-	-	-	-	-	-
2514	1 (2g)	10 (101g)	11 (190g)	-	-	-	-	-	-
2515	-	7 (8g)	-	-	-	-	-	-	-
2518	-	6 (308g)	1 (6g)	-	-	-	-	-	-
2522	-	-	2 (14g)	-	-	-	-	-	-
2524	-	3 (28g)		-	-	-	-	-	-
2525	-	12 (131g)	1 (13g)	-	-	-	-	-	-
2527	-		7 (39g)	-	-	-	-	-	-
2528	-		3 (7g)	-	-	-	-	-	-
2529	-	12 (62g)	24 (178g)	-	-	-	-	-	-
2532	-	14 (107g)	-	-	-	-	-	-	-
2533	-	1 (33g)	-	-	-	-	-	-	-

Tot	3 (17g)	153 (1878)	235 (2835)	-	-	-	-	-	1 (642g)
-----	------------	---------------	---------------	---	---	---	---	---	-------------

Trench 2 – Small finds

Small find No.	Context	Type	Number	Weight
1	3014	Iron	1	11g

Trench 2 – Other

Number	Context	Type	Number	Weight
	3002	Flint	1	1g
	3002	Pottery	10	85g
	3003	Pottery	9	72g
	3003	Bone	9	28g
	3003	Slag	7	90g
	3004	Flint	1	-
	3005	Flint	1	-
	3005	Pottery	1	4g
	3005	Bone	2	-
	3005	Slag	1	17g
	3006	Pottery	1	8g
	3006	Slag	1	130g
	3014	Pottery	9	139g
	3014	Flint	1	2g
	3014	Slag	1	32g
	3014	Bone	4	7g
	3015	Bone	20	50g
	3016	Bone	3	17g

Trench 2 - All finds by context

	Flint	Bone	Pottery	Glass	Burnt clay	Burnt stone	Quartz	Tile	Slag	Iron
3002	1 (1g)	-	10 (85g)	-	-	-	-	-	-	-
3003		9 (28g)	9 (72g)	-	-	-	-	-	7 (90g)	-
3004	1 (-)			-	-	-	-	-		-
3005	1 (-)	2 (-)	1 (4g)	-	-	-	-	-	1 (17g)	-
3006	-		1 (8g)	-	-	-	-	-	1 (130)	-
3014	1 (2g)	4 (7g)	9 (139g)	-	-	-	-	-	1 (32g)	1 (11g)
3015	-	20 (50g)	-	-	-	-	-	-	-	-
3016	-	3 (17g)	-	-	-	-	-	-	-	-

Tot	4 (3+g)	38 (83+)	30 (308)	-	-	-	-	-	10 (268)	1 (11)
-----	------------	-------------	-------------	---	---	---	---	---	-------------	-----------

Trench 3 – Small finds

Small find No.	Context	Type	Number	Weight
400	3513	Flint	1	4g
401	3545	Flint	1	1g
402	3545	Bone	1	3g
403	3513	Flint	1	2g
404	3513	Bone	1	43g
405	3513	Bone	2	7g
406	3545	Bone	17	42g
407	3545	Flint	1	4g
408	3545	Bone	1	3g
409	3545	Flint	1	3g
410	3545	Flint	1	1g
411	3545	Bone	1	1g
412	3545	Bone	3	1g
413	3545	Flint	1	1g
414	3545	Bone	4	12g
415	3514	Bone	10	75g
416	3514	Pottery	2	1g
417	3514	Bone	5	49g
418	3513	Bone	1	25g

Trench 3 – Other

	Context	Type	Number	Weight
	3500	Flint	1	2g
	3503	Glass	1	5g
	3505	Burnt clay	2	24g
	3505	Burnt stone	2	62g
	3505	Quartz	12	33g
	3506	Bone	2	3g
	3506	Bone	7	9g
	3506	Quartz	2	11g
	3508	Pottery	1	21g
	3508	Glass	3	44g
	3508	Burnt clay	2	43g
	3508	Tile	1	158g
	3508	Pottery	1	5g
	3510	Flint	1	4g
	3513	Flint	1	3g
	3517	Bone	1	14g
	3519	Bone	9	23g
	3522	Bone	9	23g
	3527	Bone	1	27g
	3527	Bone	4	2g
	3535	Flint	1	1g
	3535	Bone	1	3g

Trench 3 - All finds by context

	Flint	Bone	Pottery	Glass	Burnt clay	Burnt stone	Quartz	Tile
3500	1 (2g)	-	-	-	-	-	-	-
3503	-	-	-	1 (5g)	-	-	-	-
3505	-	-	-	-	2 (24g)	2 (62g)	12 (33g)	-
3506	-	9 (12g)	-	-	-	-	2 (11g)	-
3508	-	-	2 (26g)	3 (44g)	2 (43g)	-	-	1 (158g)
3510	1 (4g)	-	-	-	-	-	-	-
3513	3 (9g)	4 (75g)	-	-	-	-	-	-
3514	-	10 (75g)	2 (1g)	-	-	-	-	-
3517	-	1 (14g)	-	-	-	-	-	-
3519	-	9 (23g)	-	-	-	-	-	-
3522	-	9 (22g)	-	-	-	-	-	-
3527	-	5 (29g)	-	-	-	-	-	-
3535	1 1g	1 (3g)	-	-	-	-	-	-
3545	5 (10g)	27 (62g)	-	-	-	-	-	-

Totals	11 (26g)	75 (315g)	4 (27g)	4 (49g)	4 (67g)	2 (62g)	14 (44g)	1 (158g)
--------	-------------	--------------	------------	---------	---------	---------	-------------	-------------

Trench 4 – Small finds

Small find No.	Context	Type	Number	Weight
500	4003	Flint	1	- = less than 1g
501	4003	Flint	1	2g
502	4003	Pottery	7	27g
503	4003	Flint	1	-
504	4002	Flint	1	-
505	4003	Flint	1	-
506	4002	Flint	1	-
507	4003	Flint	1	-
508	4003	Flint	1	-
509	4002	Flint	1	-
510	4002	Flint	1	-
512	4002	Flint	1	-
513	4002	Flint	1	1g
514	4002	Flint	1	-
516	4002	Flint	1	-
517	4002	Flint	1	2g
518	4002	Flint	1	-
519	4002	Flint	1	-
520	4002	Flint	1	-
521	4002	Flint	1	-
522	4002	Flint	1	1g
523	4002	Flint	1	-
524	4002	Flint	1	-
525	4002	Flint	1	-
526	4002	Bone	1	2g
527	4002	Flint	1	-
528	4002	Flint	1	2g
529	4002	Flint	1	-
530	4002	Bone	1	4g
531	4002	Flint	1	-
532	4002	Flint	1	-
533	4002	Flint	1	-
534	4002	Flint	1	8g
535	4002	Flint	1	-
536	4002	Flint	1	-
537	4002	Flint	1	12g
538	4002	Flint	1	5g
539	4002	Flint	1	-
540	4002	Flint	1	-
541	4002	Flint	1	-
542	4002	Flint	1	-
543	4002	Flint	1	-
544	4002	Flint	1	-
545	4002	Flint	1	1g
546	4002	Flint	1	-
546	4002	Bone	2	-

547	4011	Flint	1	-
548	4011	Bone	1	-
549	4002	Flint	1	-
550	4002	Flint	1	-
551	4002	Flint	1	4g
553	4002	Flint	1	3g
554	4002	Bone	1	1g
556	4002	Bone	1	6g
557	4002	Flint	1	-
558	4002	Flint	1	1g
559	4002	Flint	1	-
560	4002	Flint	1	-
561	4004	Flint	1	-
562	4002	Flint	1	2g
563	4002	Flint	1	-
564	4002	Flint	1	-
565	4002	Flint	1	1g
566	4002	Flint	1	1g
567	4002	Flint	1	1g
568	4002	Flint	1	-
569	4002	Flint	1	-
570	4002	Flint	1	-
572	4002	Flint	1	-
574	4002	Flint	1	-
575	4002	Flint	1	14g
576	4002	Flint	1	-
577	4002	Bone	1	-
578	4002	Flint	1	-
579	4002	Flint	1	3g
580	4003	Flint	1	4g
581	4002	Flint	1	2g
582	4004	Pottery	7	61g
583	4003	Pottery	2	40g
584	4004	Pottery	3	12g

Trench 4 – Other

Number	Context	Type	Number	Weight
	4016	Stone	1	88g

Trench 4 - All finds by context

	Flint	Bone	Pottery	Glass	Burnt clay	Burnt stone	Quartz	Tile	Stone
4002	61 (70+g)	4 (6+g)	-	-	-	-	-	-	-
4003	7 (2+g)	-	9 (67g)	-	-	-	-	-	-
4004	1 (0-g)	-	10 (64g)	-	-	-	-	-	-
4011	1 (-g)	1 (-g)		-	-	-	-	-	-
4016	-	-	-	-	-	-	-	-	1 (88g)
Totals	70 (72+g)	5 (6+g)	19 (131g)	-	-	-	-	-	1 (88)

Trench 5 – Small finds

Small find No.	Context	Type	Number	Weight
600	4505	Pottery	1	7g
601	4505	Flint	1	4g
602	4501	Flint	1	1g
603	4505	Flint	1	5g
604	4505	Pottery	3	13g
605	4505	Pottery	1	4g
606	4505	Pottery	2	3g
607	4505	Pottery	1	9g
608	4505	Pottery	1	10g
609	4510	Pottery	1	2g
610	4510	Bone	Multiple	0g (unwashed)
611	4510	Flint	1	1g
612	4510	Bone	1	0g
613	4510	Pottery	1	2g
614	4510	Bone	1	4gb
615	4514	Flint	1	3g
618	4527	Bone	8	3g
619	4527	Bone	Multiple	9g (unwashed)
620	4527	Bone	1	4g
621	4506	Flint	1	1g
622	4506	Flint	1	4g
623	4506	Flint	1	1g
624	4530	Pottery	1	4g
625	4527	Bone	10	4g (unwashed)
626	4506	Flint	1	1g

Trench 5 – Other

Number	Context	Type	Number	Weight
	4507	Bone	10	26g
	4507	Bone	9	8g
	4510	Bone	30	55g

Trench 5 - All finds by context

	Flint	Bone	Pottery	Glass	Burnt clay	Burnt stone	Quartz	Tile
4501	1 (1g)	-	-	-	-	-	-	-
4505	2 (9g)	-	9 (46g)	-	-	-	-	-
4506	4 (7g)	-	-	-	-	-	-	-
4507	-	19 (34)	-	-	-	-	-	-
4510	1 (1g)	32 (59g)	2 (4g)	-	-	-	-	-
4514	1 (3g)	-	-	-	-	-	-	-
4527	-	19 (19g)	-	-	-	-	-	-

4530	-	-	1 (4g)	-	-	-	-	-
------	---	---	--------	---	---	---	---	---

Totals	9 (21g)	70 (111g)	12 (54g)	-	-	-	-	-
--------	------------	--------------	-------------	---	---	---	---	---

Total finds from each trench (Numbers in black, weight in blue).

	Flint	Bone	Pot	Glass	Clay	Burnt stone	Quartz	Tile	Brick	Slag	Iron	Stone
T 1	3 17	153 1878	235 2835	-	-	-	-	-	1 642	-	-	-
T 2	4 3+	38 83+	30 308	-	-	-	-	-	-	10 268	1 11	-
T 3	11 26	75 315	4 27	4 49	4 67	2 62	14 44	1 150	-	-	-	-
T 4	70 72	5 6+	19 131	-	-	-	-	-	-	-	-	1 88
T 5	9 21	70 111	12 54	-	-	-	-	-	-	-	-	-

Total finds

	97 139	341 2393	300 3355	4 49	4 62	2 62	14 44	1 150	1 642	10 268	1 11	1 88
--	-----------	-------------	-------------	---------	---------	---------	----------	----------	----------	-----------	---------	---------

APPENDIX 2: GEOPHYSICS REASSESSMENT

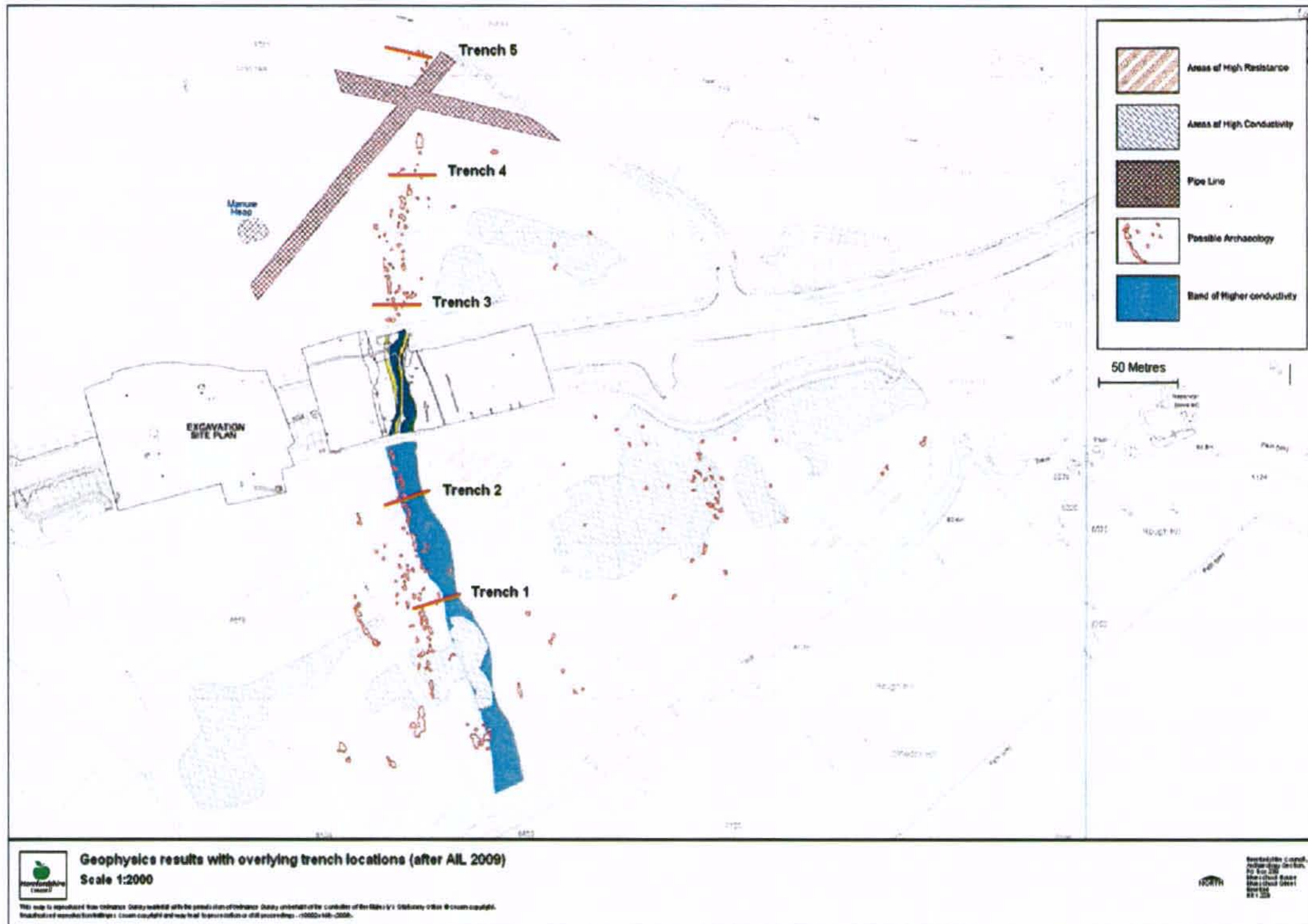

2010 Geophysical survey results

Summary Assessment

Trench 1

The probable Roman trackway complex in the centre of the trench does coincide with geophysics responses in that area. However, at the east end of the trench, a possible linear trackway (overlain by a fill including a deposit of large stones) and an associated ditch of significant size were not recognised by the geophysics.

The east end of the trench had, in fact, been placed to coincide with a north–south band of higher conductivity, but no feature was identified which explained or coincided with this response.

Trench 2

The principal hollow and associated surfaces and features broadly corresponded with the resistivity anomalies.

As in Trench 1, the east end of the trench had been placed to coincide with the area of higher conductivity, but no clear feature was identified which explained or coincided with this response.

Trench 3

The principal hollow and the associated surface (a probable extension of the Rotherwas Ribbon) and features indistinctly corresponded with the resistivity anomalies, but the specific ‘match’ was less clear than in Trench 2 and the central part of Trench 1

Trench 4

The principal hollow/channel indistinctly corresponded with the resistivity anomalies, although there was no clear indication of the scale or nature of the feature, and its distinction from the features in other trenches.

Trench 5

The geophysical survey of this area, although broadly indicating the presence of cultural deposits, in no way highlighted the complexity of the underlying archaeology. In the main section of the trench there were three overlying metallised surfaces, one of which that is currently thought to be a burnt mound. Although it is reasonable to assume that three separate overlying surfaces would not be identified as separate entities, the burnt mound might have been expected to show a coherent response. However, with hindsight, anomalies at the east end of the trench can be correlated with the pits in that area.

Recommendations

Although features were generally identified in the areas of geophysics responses, specific correlations are less clear. Given the range and varied chronology of the deposits which were found across the five trenches, it is unclear if there would be significant further benefit in further interrogation of the geophysics data in the light of the excavation results

APPENDIX 3: GEOARCHAEOLOGY - PROFILE DESCRIPTIONS

Profile 1: Trench 2 (North side)

10/02/10

context	Depth (cm)	Unit	description	
3000	0-32	M1	Brown (7.5YR 4/3) almost stone-free humic silty loam, soft weak small subangular blocky to large crumb structure, common fine fleshy and rare medium fleshy and fibrous roots, clear to abrupt boundary. <u>Ap – soil developed in colluvium</u>	
3003/ 3005	32-41		Strong brown (7.5YR 4/6) (greyish hue) silty sand loam with weak medium subangular blocky structure, clear boundary. <u>B1 – soil developed in colluvium</u>	
3005	41-53		Dark brown (7.5YR 3/4) dark brown massive stone-free silty sand loam. <u>Colluvium</u>	
3017	53-58/9		K1	Dark brown 7.5YR 3/3 massive silty sand loam, with rare fine charcoal and but with rare small stones (as above but with charcoal, stones and darker hue), abrupt boundary. <u>Stone-dominated layer</u>
3021	59+			Dark reddish brown (5YR 3/3) massive silty clay loam, with rare small green and yellow sandstone fragments. <u>Rw – weathered parent material – ‘natural’</u>

Summary: Thin stone-dominated layer with overlying and underlying stratigraphy
 Monolith 1 26-76cm with AEA, propose discard
 Kubiena 1 54-62cm through stony layer with AEA, consider soil micromorphology

Profile 2: Trench 3

9/3/10

context	Depth* (cm)	Unit	description
3501	0-14	Monolith 181	Brown (7.5YR 4/3) silty clay with moderate medium blocky/prismatic structure, rare very fine fleshy roots, stone-free, clear to abrupt boundary.
3513 (=3522)	14-32		Brown (7.5YR 4/4) massive fine sandy silt loam, essentially stone-free, many fine sand, coarse silt grains visible, , coarsening downwards, abrupt boundary. <u>Silty colluvium</u>
3514	32-44		Brown (7.5YR 4/4) sandy loam with abundant small and common medium stones randomly arranged – some vertically orientated – abrupt boundary. <u>Stone-dominated layer</u>
3522	44-50+		Dark reddish brown (5YR 3/4) massive silty clay loam. <u>Rw</u>

* depth in monolith
 Monolith 181 = 50cm with AEA, propose photograph stone orientation

Profile 3: Trench 4 Bronze Age flint layer next to palaeo-valley 9/3/10

context	Depth (cm)	Unit	description
4031?	0+		Greyish brown (10YR 5/2) stone-free silty loam, weak medium blocky/ prismatic structure. <u>Alluvial (blue/grey) silt</u>
4003	0-6		Brown (7.5YR 4/3-4) (but looks grey) stone-free coarse silt/fine silty loam, with very fine distinct mottles of yellowish brown (10YR 5/6-8), abrupt to clear boundary. <u>Colluvium</u>
4002	6-18		Reddish brown (5YR 4/2) to Brown (7.5YR 4/4) stone-free silt loam to silty sand loam, with small to medium subangular blocky structure. <u>Mesolithic/Bronze Age flint layer (bA) developed in colluvium</u>
?4034	18+		As above but sandy loam with no structure observable. <u>bB base of soil developed in colluvium</u>

Profile 4: Trench 4 palaeo-valley 9/3/10

context	Depth* (cm)	Unit	description
4031	0-4	176	Yellowish brown (10YR 5/4) loose fine to medium sand, abrupt boundary <u>Sand</u>
4005	4-13		Greyish brown (10YR 5/2) silty clay, stone-free, medium crumb structure, abrupt boundary <u>Edge of incipient soil developed in / over palaeo-valley alluvium</u>
4009	13-45		Greyish brown (10YR 5/2) to brown (7.5YR 4/2) brown firm silty clay, stone-free, rare very small charcoal fragments, clear boundary <u>Palaeo-valley alluvial (colluvial) fill</u>
4011	45-50		Greyish brown (10YR 5/2) to grey (10YR 5/1) massive silt, abrupt boundary <u>Basal deposit of palaeo-valley [4027]</u>
4035	50-52+		Brown (7.5YR 4/4) silty sand loam, stone-free <u>Rw</u>

* depth in from sampled soil - upper 34cm monolith empty
 Monolith 176 = 86cm taken by WHEAS for subsampling for pollen

Profile 5: Trench 4 soil in palaeo-valley

9/3/10

<i>context</i>	<i>Depth (cm)</i>	<i>Unit</i>	<i>description</i>
4031			
4004	0-5.5		Greyish brown (2.5Y 5/2) missive stone-free silty sand, clear to abrupt wavy boundary. <u>Colluvium</u>
4024	0-11		Greyish brown (2.5Y 5/2) greyish brown stone-free silt silt to silty sand with clear fine blocky / prismatic structure, clear boundary. <u>Ag – gleyed soil developed in valley fill</u>
4025	11-17		Yellowish red (5YR 5/6) massive silt. <u>A – soil developed in palaeo-valley fill</u>
4026	17+		<u>B – lower part of soil horizon in palaeo-valley fill</u>

Profile 6: Trench 4 basal stone deposit in valley [4027]

(north side) 9/3/10

<i>context</i>	<i>Depth* (cm)</i>	<i>Unit</i>	<i>description</i>
4009	0-16	Monolith 180	0-5cm: dark greyish brown (10YR 4/2) stone-free sandy <u>silt loam</u> , some fine (much degraded) charcoal to 4mm, weak to moderate medium to large prismatic structure, over 5-16cm: brown (10YR 4/3)stone-free causer sandy silt loam, no structure evident sandy abrupt boundary, weakly gleyed, sorted fluvial deposit. <u>Grey silty clay palaeo-valley fill</u>
	16-22		Rounded medium gravel stones in a greyish brown (10YR 5/2) oxidising to yellowish brown (10YR 5/6) silty matrix, abrupt boundary. <u>Gravel = gravel base of palaeo-valley [4027]</u>
4036	22-25+		Medium and fine sandy matrix (orange) with few medium and small subrounded stone <u>Gleyed fill of palaeo-valley [4033]</u>

* depth in monolith
Monolith 180 = 25cm

with AEA

Profile 7: Trench 4

context	Depth (cm)	Unit	description
4001	0-9	186	Brown (7.5YR) silty loam, massive, very rare fine charcoal fragments, stone-free, clear to abrupt boundary
4031	9-16		Brown (7.5YR 5/3) firm silty clay loam with some medium rounded stones lying flat, clear boundary
4003	16-22		Brown (10YR 4/2) firm stone-free silty clay – very weak small blocky structure, clear-abrupt boundary <u>Insipient soil in colluvium</u>
4002	22-50		Reddish brown (5YR 4/4) to brown (7.5YR 4/4) stone free silty clay loam, stone-free <u>Colluvium</u>
4034			Gravels Rw

Monolith 186 = 50cm (with WHEAS)

Profile 8: Trench 5 (North side)

16/03/10

context	Depth (cm)	Unit	description
4507	3-8 [0-4]	199	Brown (7.5YR 5/3 -4/2) firm silt to silt loam matrix with weak medium blocky structure, stone-free, rare fine charcoal fragments, clear boundary <u>bA Buried soil</u>
4534	8-15 [4-11]		As above but with abundant medium and large subangular and angular gravel, many in near vertical positions (rare subrounded) - separated by a thin (10-15mm) stone-free band (see clast record 2) and a small fleck of charcoal (see clast record 1). <u>Stones – burning and charcoal</u>
4532	15-32 [11-28]		Brown (7.5YR 4/3-4) stone-free firm silt/silt loam with weak large, subangular blocky structure, rare vertical macropores to 7mm (most 4-5mm), clear to abrupt boundary.
4515	32-51 [28-47]		Dark brown (7.5YR 3/4) common-many medium stones in a silty clay loam with some fine sand matrix, slightly more ?humic, with common fine charcoal flecks, clear boundary <u>Possible stabilisation of the stony lens above main done-dominated layer</u>
4523	51-66 [47-50+]		Greenish grey (gley 1 6/1) silty loam/silty sand loam, stone-free <u>Rw – cryoturbated parent material</u>
4523	66+		Brown (7.5YR 4/4) massive clay, with common fine to small clear mottles of greenish grey (Gley 1 5/1). <u>Rw – parent material</u>

depths in [square parentheses] = depth in monolith

Monolith 199 = 50cm (with WHEAS)

APPENDIX 4: GEOARCHAEOLOGY- CLAST RECORDS (0.5 x 0.5m quadrats)

Clast Record 1: Trench 5 (lower stone layer – 2 layers above stone-dominated layer)
16/03/10

<i>Tr / context</i>	<i>size</i>	<i>Angular</i>	<i>Sub- angular</i>	<i>Sub- rounded</i>	<i>rounded</i>	<i>total</i>
Tr 5 /4531	>5mm	-	6	6	-	12
Tr 5 /4531	<5mm	-	-	-	-	0
Tr 5 /4531	>10mm	-	10	1	-	11
	<i>Totals</i>	<i>0</i>	<i>16</i>	<i>7</i>	<i>0</i>	<i>23</i>

Qtz = 0

3 87 17 21 2

Clast Record 2: Trench 5 (upper stone layer – 2 layers above stone-dominated layer)
16/03/10

<i>Tr / context</i>	<i>size</i>	<i>Angular</i>	<i>Sub- angular</i>	<i>Sub- rounded</i>	<i>rounded</i>	<i>total</i>
Tr 5 / 4506	>5mm	-	38	1	-	39
Tr 5 / 4506	<5mm	-	-	3	1	4
Tr 5 / 4506	>10mm	1	2	1	-	4
	<i>Totals</i>	<i>1</i>	<i>40</i>	<i>5</i>	<i>1</i>	<i>47</i>

Qtz = 1

3 2 86 1 12

Qtz 7

Clast Record 3: Trench 3 stone-dominated layer
9/03/10

<i>Tr / context</i>	<i>size</i>	<i>Angular</i>	<i>Sub- angular</i>	<i>Sub- rounded</i>	<i>rounded</i>	<i>total</i>
Tr 3 / 3514	>5mm	-	51	1	-	52
Tr 3 / 3514	<5mm	-	57	13	-	70
Tr 3 / 3514	>10mm	-	-	-	-	0
	<i>Totals</i>	<i>0</i>	<i>108</i>	<i>14</i>	<i>0</i>	<i>122</i>

Qtz = 5: Sst = 3

Dip orientation of medium stones from 3514

87° 62° 57° 3° 6° 12° 12° 4° 8° -°
7° 6° 0° 1° 2° 4° 19° 4° 5° 64°
41° 1° 0° 14° 3° 3° 2° 10° 7° 4°

No = 30

Clast Record 4: Trench 3 stone-dominated layer
9/03/10

<i>Tr / context</i>	<i>size</i>	<i>Angular</i>	<i>Sub- angular</i>	<i>Sub- rounded</i>	<i>rounded</i>	<i>total</i>
Tr 3 / 3514b	>5mm	-	4	53	-	57
Tr 3 / 3514b	<5mm	-	-	42	-	42
Tr 3 / 3514b	>10mm	-	-	-	-	0
	<i>Totals</i>	0	4	95	0	99

Qtz = 1: Sst = 2

Dip orientation of medium stones 3514b

0° 1° 2° 1° 6° 6° 2° 6° 1° 0°
1° 3° 7° 3° 4° 1° 2° - - 3°
16° 30° 1° 0° 0° 2° 1° 0°

No = 28

Clast Record 5: Trench 3 natural gravels east edge of stone-dominated layer
9/03/10

<i>Tr / context</i>	<i>size</i>	<i>Angular</i>	<i>Sub- angular</i>	<i>Sub- rounded</i>	<i>rounded</i>	<i>total</i>
Tr 3 / nat	>5mm	-	6	2	1	9
Tr 3 / nat	<5mm	-	27	2	-	29
Tr 3 / nat	>10mm	-	3	-	1	4
	<i>Totals</i>	0	36	4	2	42

Qtz = 0: Sts = 3

Dip orientation of medium stones 'natural' gravels east of stone-dominated layer

0° 1° 14° 7° 3° 6° 4° 5° 8° 16°
27° 38° 3°

No = 13

Clast Record 6: Trench 4 natural gravels west end

<i>Tr / context</i>	<i>size</i>	<i>Angular</i>	<i>Sub- angular</i>	<i>Sub- rounded</i>	<i>rounded</i>	<i>total</i>
Tr 4 / 4029	>5mm	-	15	-	-	15
Tr 4 / 4029	<5mm	c. 10	86	2	-	98
Tr 4 / 4029	>10mm	-	2	1	-	3
	<i>Totals</i>	10	103	3	0	116

Qtz = 6: Sts = 4

Dip orientation of medium stones in 4029

0° 1° 2° 0° 1° 3° 0° 1° 1° 17° 6°

No = 10

Tr 5: A series of records were made of gravels contexts. From west to east these included contexts 4514, 4510, 4515 and orientated gravels 4520, natural 4504, fine gravel and cobbles 4505

(4514✓ west side higher, 4510× edge, 4515✓ edge, 4520✓ orientated natural gravel, 4504✓ natural gravel higher, and fine gravel cobbles east end 4504×)

Clast Record 7: Trench 5 gravels 4515 9/3/10

<i>Tr / context</i>	<i>size</i>	<i>Angular</i>	<i>Sub-angular</i>	<i>Sub-rounded</i>	<i>rounded</i>	<i>total</i>
Tr 5 / 4515	>5mm	-	34	3	-	37
Tr 5 / 4515	<5mm	-	15		3	18
Tr 5 / 4515	>10mm	-	5	-	-	5
	<i>Totals</i>	0	39	15	3	60

Qtz = 3; Sts = 3

Dip orientation of medium stones in 4515

0° 2° 3° 1° 4° 4° 3° 0° -1° 1°
 3° 4° 4° 3°

No = 14

Clast Record 8: Trench 5 gravels 4514 9/3/10

<i>Tr / context</i>	<i>size</i>	<i>Angular</i>	<i>Sub-angular</i>	<i>Sub-rounded</i>	<i>rounded</i>	<i>total</i>
Tr 5 / 4514	>5mm	-	37	8	-	45
Tr 5 / 4514	<5mm	-	12	-	-	12
Tr 5 / 4514	>10mm	-	1	3	-	4
	<i>Totals</i>	0	50	11	0	61

Qtz = 1; Sst = 2

Dip orientation of medium stones in 4514

0° 1° 3° 12° 0° 2° 2° 1° 1° 3°
 4° 4°

No = 12

Clast Record 9: Trench 5 gravels 4504 9/3/10

<i>Tr / context</i>	<i>size</i>	<i>Angular</i>	<i>Sub-angular</i>	<i>Sub-rounded</i>	<i>rounded</i>	<i>total</i>
Tr 5 / 4504	>5mm	-	-	4	-	4
Tr 5 / 4504	<5mm	-	167		-	167
Tr 5 / 4504	>10mm	-	-	-	-	-
	<i>Totals</i>	0	0	167	4	171

Qtz = 1; Sst = 0

Dip orientation of medium stones in 4505

1° 3° 0° 2° 1°

No = 5

Clast Record 10: Trench 5 orientated natural gravels 4520 9/3/10

<i>Tr / context</i>	<i>size</i>	<i>Angular</i>	<i>Sub- angular</i>	<i>Sub- rounded</i>	<i>rounded</i>	<i>total</i>
Tr 5 / 4520	>5mm	-	4	98	3	105
Tr 5 / 4520	<5mm	-	-	11	-	11
Tr 5 / 4520	>10mm	-	1	-	-	1
	<i>Totals</i>	0	5	109	3	117

Qtz = 6: Sts = 2

Dip orientation of medium stones in 4520

90° 87° 88° 89° 87° 94° 96° 2° 2° 1°

0° 7° 2° 1°

No = 14

Compass orientation of medium stones in 4520

346° 347° 345° 3° 346° 347° 348° 365° 345° 274°

No = 10

Appendix 3.2 Clast volume and wt

Trench	Tr 1	Tr 1	Tr 2	Tr 2	Tr 4	Tr 4	Tr 4	Tr 4	Tr 5	Totals
context	2517	2532	3006	3017	4008	4011	4028	4029	4515	
Vol. processed (L)	40	50	50	20	30	50	20	20	20	300
Total Stones	426	255	508	512	2076	651	414	606	752	6200
Total Weight (g)	19659	27490	27201	27529	15187	25886	8251	11335	10920	173458

Data of volume processed vs number and weight of stones

APPENDIX 5: GEOARCHAEOLOGY – LITHOLOGICAL AND SHAPE CHARACTERISTICS

Appendix 5.1: Raw stone roundness data

Appendix 5.2: Results of cluster analysis

Appendix 5.3: Pearson correlation coefficients for samples

Appendix 5.4: Factor loadings (1 and 2) for lithology

Appendix 5.5: Casewise factor scores (1 and 2)

Appendix 5.6: Graphical comparison of the stone roundness data from trenches 2-5.

Appendix 5.1: Raw stone roundness data

	Trench context		Tr 2	Tr 2	Tr 3	Tr 3	Tr 4	Tr 4	Tr 4	Tr 4	Tr 5	Totals
Size			2517	2532	3006	3017	4008	4011	4028	4029	4515	
50mm	Angular	No.	0	1	0	0	0	0	1	0	0	2
		(g)	0	130	0	0	0	0	610	0	0	740
	Subangular	No.	10	30	20	18	0	6	1	5	1	91
		(g)	3100	9442	5845	5742	0	2875	355	1075	125	28559
	Subrounded	No.	18	21	22	19	4	17	2	4	5	112
		(g)	5025	6385	7148	6123	650	4857	346	1400	1450	33384
	Rounded	No.	0	1	0	0	0	5	1	1	1	9
		(g)	0	261	0	0	0	1611	125	260	273	2530
25mm	Angular	No.	7	1	5	0	8	8	1	0	3	33
		(g)	310	70	268	0	275	659	100	0	86	1768
	Subangular	No.	42	75	77	63	43	67	29	24	16	436
		(g)	2376	5925	3675	5082	1675	4345	1517	1408	947	26950
	Subrounded	No.	125	64	123	113	66	102	34	43	45	715
		(g)	6523	4285	7841	7358	2847	6645	1850	2480	2474	42303
	Rounded	No.	0	0	0	0	3	31	16	25	58	133
		(g)	0	0	0	0	135	1818	655	1184	2858	6650
14mm	Angular	No.	0	0	0	1	79	3	1	5	3	92
		(g)	0	0	0	3	775	60	21	70	37	966
	Subangular	No.	39	21	70	56	227	45	53	81	42	634
		(g)	525	400	925	1018	2375	609	668	998	452	7970
	Subrounded	No.	107	27	82	138	346	81	95	107	142	1125
		(g)	1630	550	1300	2000	3518	1411	1225	1166	761	13561
	Rounded	No.	4	1	0	4	12	49	36	54	55	215
		(g)	62	25	0	58	150	725	390	628	700	2738
10mm	Angular	No.	0	0	0	0	76	0	1	0	3	80
		(g)	0	0	0	0	198	0	12	0	15	225
	Subangular	No.	6	3	21	10	413	15	18	48	33	567
		(g)	20	10	50	25	930	50	75	164	130	1454
	Subrounded	No.	19	0	17	18	603	30	36	71	113	907
		(g)	50	0	58	71	1380	100	167	225	370	2421
	Rounded	No.	4	0	0	0	48	8	21	61	33	175
		(g)	6	0	0	0	125	25	60	179	101	496
5mm	Angular	No.	0	0	0	1	2	0	0	0	3	6
		(g)	0	0	0	2	4	0	0	0	5	11
	Subangular	No.	4	4	21	26	87	26	11	22	20	221
		(g)	5	4	27	20	77	23	23	28	20	227
	Subrounded	No.	31	6	42	39	59	74	32	33	128	444
		(g)	22	3	50	24	73	48	27	45	104	396
	Rounded	No.	10	0	8	6	0	84	25	22	48	203
		(g)	5	0	14	3	0	25	25	25	12	109
Total Stones			426	255	508	512	2076	651	414	606	752	6200
Total Weight (g)			19659	27490	27201	27529	15187	25886	8251	11335	10920	173458

Appendix 5.2: Results of cluster analysis

Hierarchical Clustering Results for coarse gravel fraction						
Quantitative Data Set = cluster1!\$B\$13:\$R\$18						
Distance/Similarity Measure = Pearson Correlation						
Cluster Method = Nearest Neighbour						
Similarity Matrix (Pearson Correlation)						
	greywacke	silt/sh	sst	qtz	ig	ors
greywacke		0.759	0.928	0.641	0.798	0.074
silt/sh	0.759		0.629	0.946	0.513	-0.319
sst	0.928	0.629		0.525	0.748	0.233
qtz	0.641	0.946	0.525		0.490	-0.355
ig	0.798	0.513	0.748	0.490		-0.003
ors	0.074	-0.319	0.233	0.355	0.003	
Clustering Strategy						
Cluster	1st Item	2nd Item	Similarity			
1	qtz	silt/sh	0.946			
2	sst	greywacke	0.928			
3	Cluster 2	ig	0.798			
4	Cluster 3	Cluster 1	0.759			
5	Cluster 4	ors	0.233			
Cophenetic Correlation						
R	DF	P				
0.928	13	0.000				

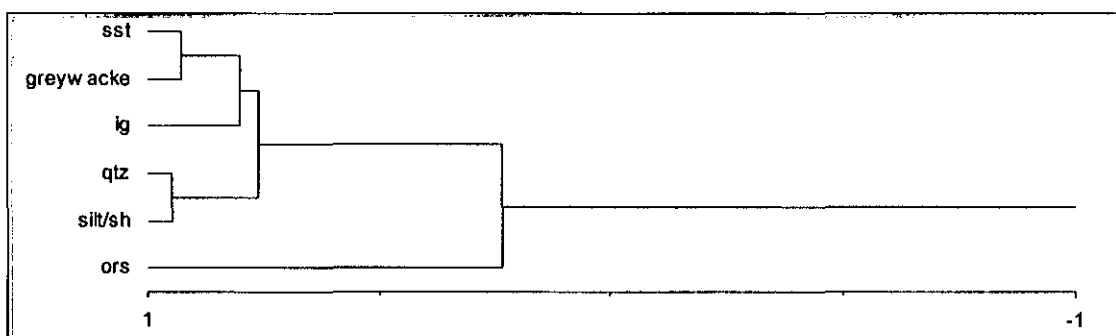

Hierarchical Clustering Results for finer gravel fraction
Quantitative Data Set = cluster1\SB\$21;SR\$26
Distance/Similarity Measure = Pearson Correlation
Cluster Method = Nearest Neighbour

Similarity Matrix (Pearson Correlation)

	greywacke	silt/sh	sst	qtz	ig	ors
greywacke		0.952	0.902	0.890	0.743	0.034
silt/sh	0.952		0.872	0.909	0.578	-0.032
sst	0.902	0.872		0.756	0.554	0.095
qtz	0.890	0.909	0.756		0.638	-0.332
ig	0.743	0.578	0.554	0.638		0.074
ors	0.034	-0.032	0.095	0.332	0.074	

Clustering Strategy

Cluster	1st Item	2nd Item	Similarity
1	silt/sh	greywacke	0.952
2	Cluster 1	qtz	0.909
3	Cluster 2	sst	0.902
4	Cluster 3	ig	0.743
5	Cluster 4	ors	0.095

Cophenetic Correlation

R	DF	P
0.966	13	0.000

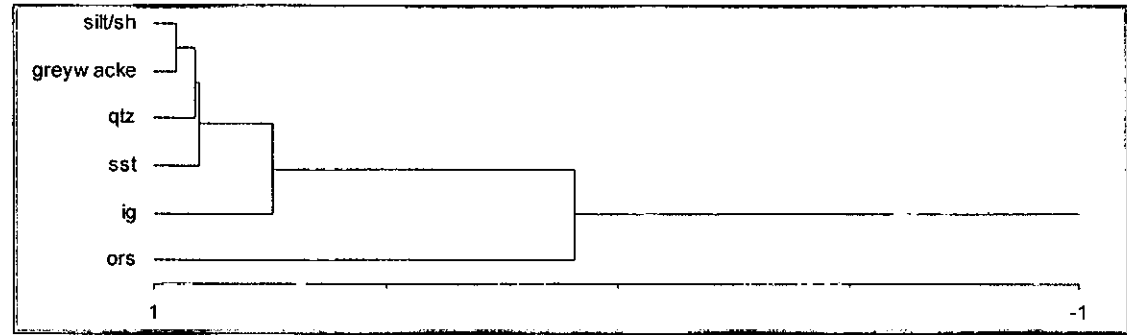

Coarser fraction

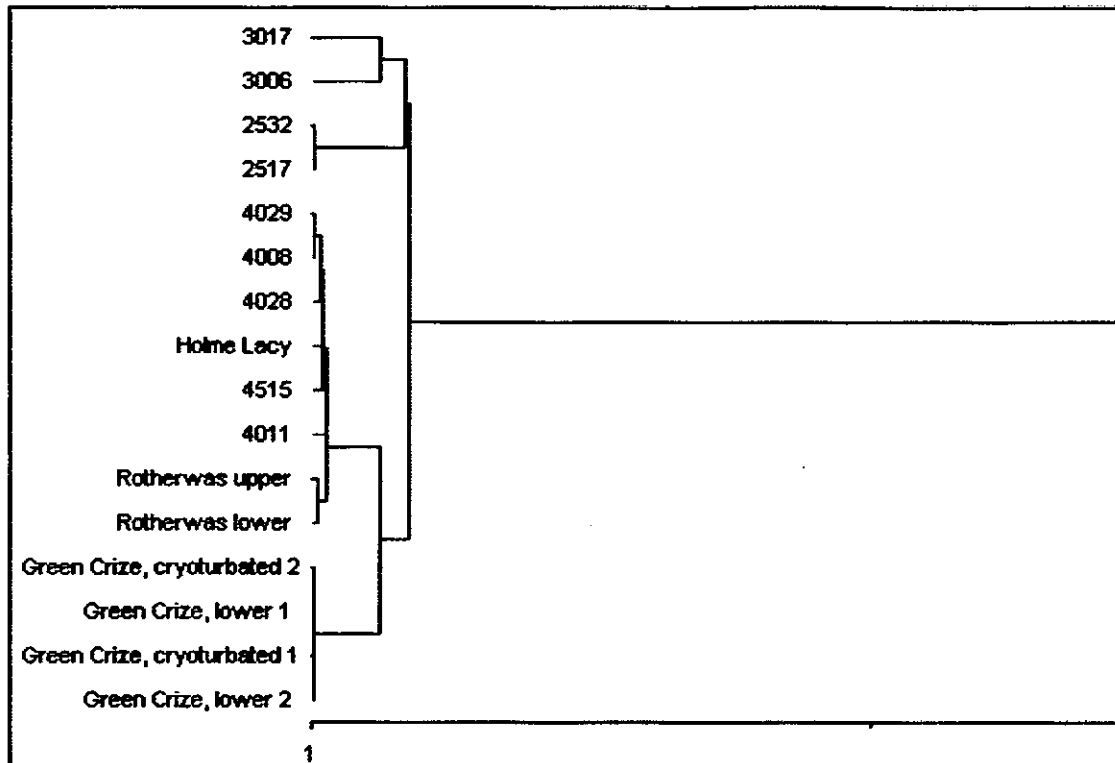

Finer fraction

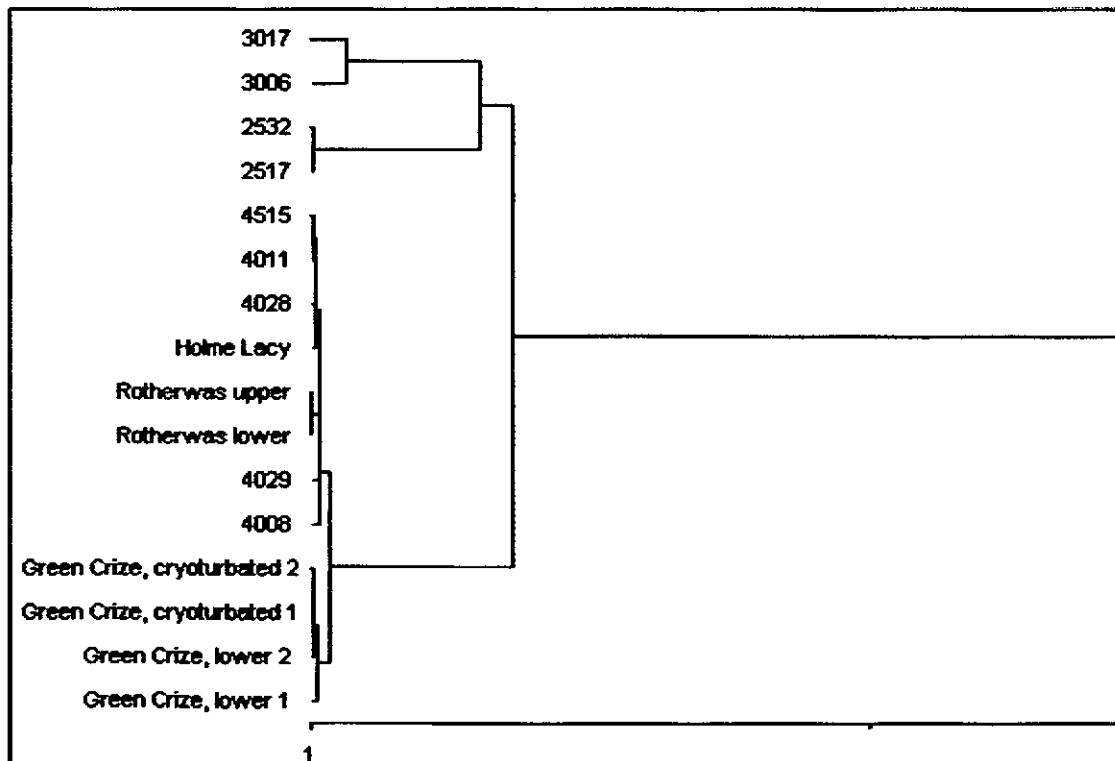

Appendix 5.3: Pearson correlation coefficients for samples

	2517	2532	3006	3017	4008	4011	4028	4029	4515	GLC1	GLC2	GCC1	GCC2	RL	RU	HL
2517		0.999	0.900	0.700	-0.106	-0.187	-0.155	-0.097	-0.115	0.314	0.413	0.406	0.360	-0.021	-0.087	-0.141
2532	0.999		0.918	0.730	-0.063	-0.151	-0.114	-0.055	-0.070	0.358	0.456	0.449	0.403	0.027	-0.040	-0.100
3006	0.900	0.918		0.939	0.261	0.119	0.213	0.259	0.278	0.668	0.747	0.736	0.705	0.384	0.318	0.200
3017	0.700	0.730	0.939		0.548	0.392	0.507	0.539	0.572	0.867	0.914	0.905	0.891	0.657	0.606	0.478
4008	-0.106	-0.063	0.261	0.548		0.960	0.991	0.998	0.991	0.873	0.810	0.825	0.854	0.941	0.960	0.982
4011	-0.187	-0.151	0.119	0.392	0.960		0.976	0.970	0.926	0.748	0.668	0.691	0.726	0.830	0.855	0.987
4028	-0.155	-0.114	0.213	0.507	0.991	0.976		0.992	0.982	0.842	0.771	0.786	0.820	0.920	0.938	0.992
4029	-0.097	-0.055	0.259	0.539	0.998	0.970	0.992		0.987	0.870	0.806	0.823	0.850	0.936	0.952	0.991
4515	-0.115	-0.070	0.278	0.572	0.991	0.926	0.982	0.987		0.896	0.838	0.848	0.875	0.975	0.987	0.967
GLC1	0.314	0.358	0.668	0.867	0.873	0.748	0.842	0.870	0.896		0.993	0.994	0.998	0.940	0.915	0.827
GLC2	0.413	0.456	0.747	0.914	0.810	0.668	0.771	0.806	0.838	0.993		0.999	0.996	0.900	0.867	0.756
GCC1	0.406	0.449	0.736	0.905	0.825	0.691	0.786	0.823	0.848	0.994	0.999		0.998	0.904	0.873	0.774
GCC2	0.360	0.403	0.705	0.891	0.854	0.726	0.820	0.850	0.875	0.998	0.996	0.998		0.920	0.894	0.804
RL	-0.021	0.027	0.384	0.657	0.941	0.830	0.920	0.936	0.975	0.940	0.900	0.904	0.920		0.994	0.904
RU	-0.087	-0.040	0.318	0.606	0.960	0.855	0.938	0.952	0.987	0.915	0.867	0.873	0.894	0.994		0.918
HL	-0.141	-0.100	0.200	0.478	0.982	0.987	0.992	0.991	0.967	0.827	0.756	0.774	0.804	0.904	0.918	

coarser fraction

	2517	2532	3006	3017	4008	4011	4028	4029	4515	GLC1	GLC2	GCC1	GCC2	RL	RU	HL
2517		0.999	0.824	0.681	-0.107	-0.074	-0.053	0.033	-0.087	0.208	0.297	0.329	0.344	-0.093	-0.067	-0.134
2532	0.999		0.850	0.714	-0.053	-0.020	-0.001	0.087	-0.034	0.259	0.348	0.379	0.394	-0.040	-0.015	-0.081
3006	0.824	0.850		0.968	0.392	0.450	0.475	0.554	0.430	0.679	0.748	0.758	0.770	0.430	0.448	0.409
3017	0.681	0.714	0.968		0.507	0.562	0.582	0.660	0.540	0.750	0.808	0.807	0.819	0.534	0.548	0.535
4008	-0.107	-0.053	0.392	0.507		0.987	0.973	0.971	0.992	0.930	0.893	0.878	0.878	0.970	0.970	0.979
4011	-0.074	-0.020	0.450	0.562	0.987		0.997	0.991	0.999	0.957	0.925	0.907	0.907	0.989	0.989	0.996
4028	-0.053	-0.001	0.475	0.582	0.973	0.997		0.993	0.994	0.964	0.935	0.917	0.916	0.993	0.993	0.995
4029	0.033	0.087	0.554	0.660	0.971	0.991	0.993		0.988	0.983	0.963	0.949	0.948	0.983	0.985	0.985
4515	-0.087	-0.034	0.430	0.540	0.992	0.999	0.994	0.988		0.952	0.918	0.902	0.901	0.990	0.990	0.994
GLC1	0.208	0.259	0.679	0.750	0.930	0.957	0.964	0.983	0.952		0.995	0.990	0.990	0.952	0.958	0.939
GLC2	0.297	0.348	0.748	0.808	0.893	0.925	0.935	0.963	0.918	0.995		0.997	0.998	0.918	0.927	0.904
GCC1	0.329	0.379	0.758	0.807	0.878	0.907	0.917	0.949	0.902	0.990	0.997		0.998	0.908	0.918	0.883
GCC2	0.344	0.394	0.770	0.819	0.878	0.907	0.916	0.948	0.901	0.990	0.998	0.998		0.900	0.910	0.881
RL	-0.093	-0.040	0.430	0.534	0.970	0.989	0.993	0.983	0.990	0.952	0.918	0.908	0.900		1.000	0.989
RU	-0.067	-0.015	0.448	0.548	0.970	0.989	0.993	0.985	0.990	0.958	0.927	0.918	0.910	1.000		0.987
HL	-0.134	-0.081	0.409	0.535	0.979	0.996	0.995	0.985	0.994	0.939	0.904	0.883	0.881	0.989	0.987	

finer fraction

Appendix 5.4: Factor loadings (1 and 2) for lithology

Unrotated factor loadings: coarser fraction

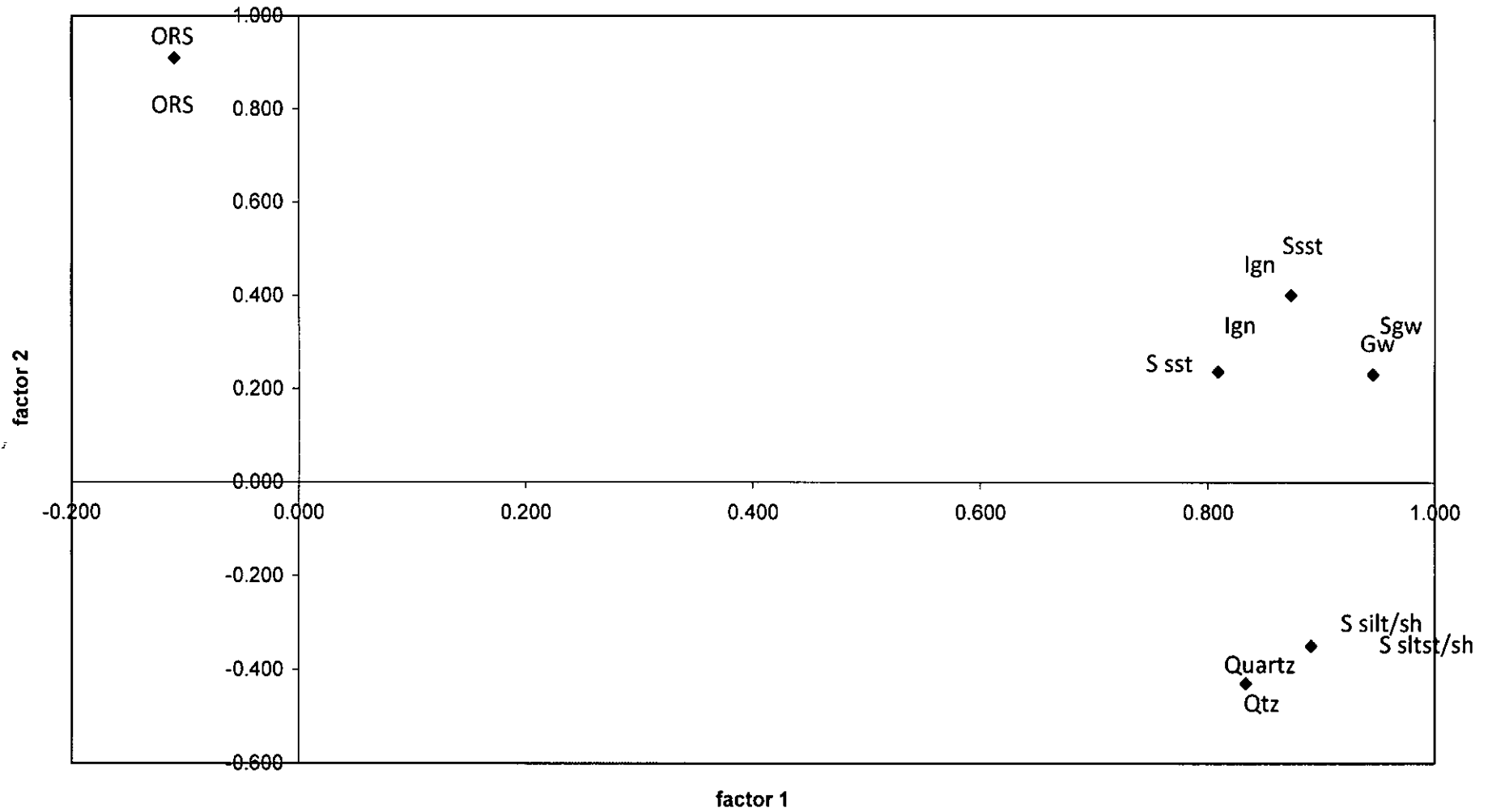

unrotated factor loadings:finer fraction

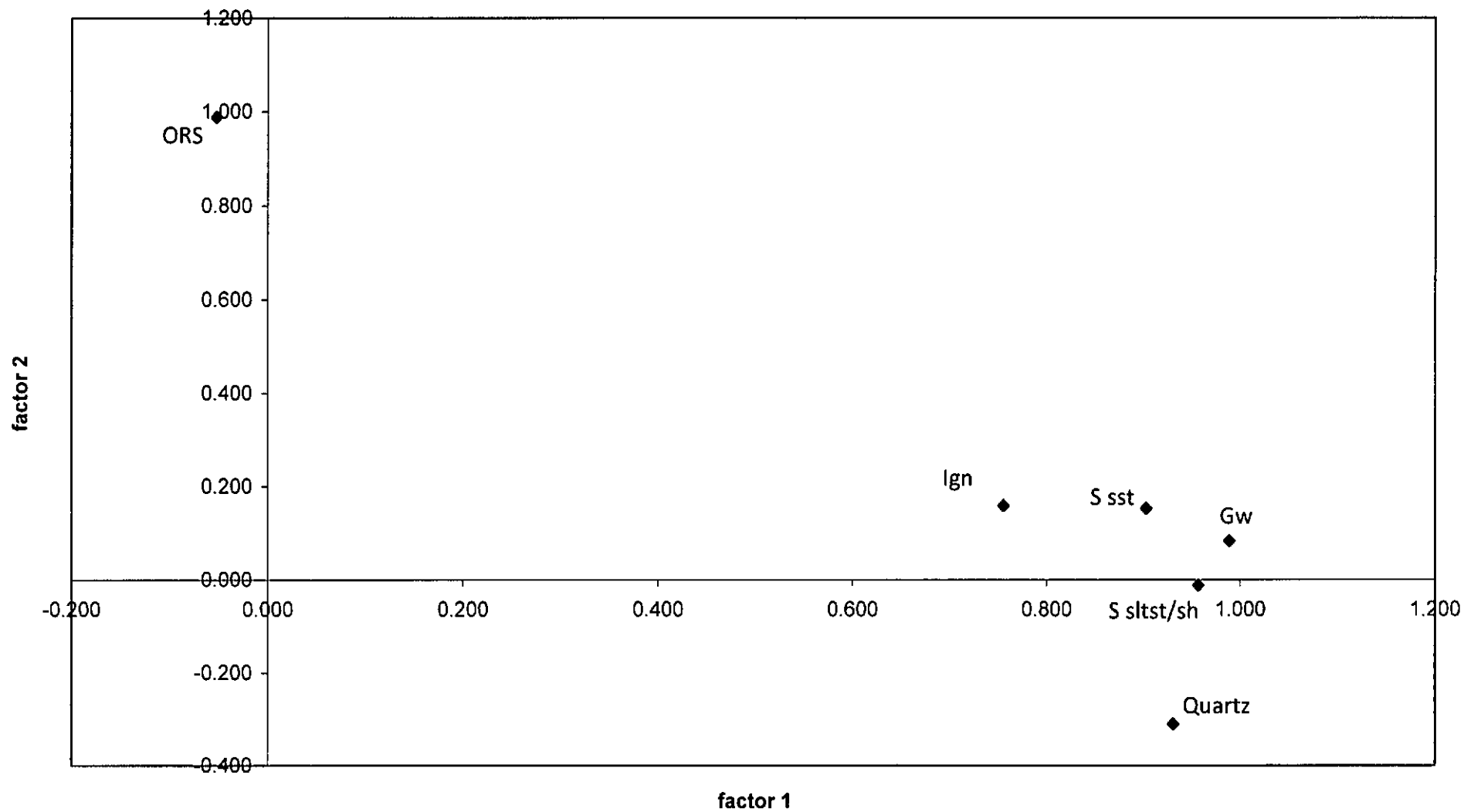

Appendix 5.5: Factor scores (1 and 2) for samples

casewise factor scores: coarser fraction

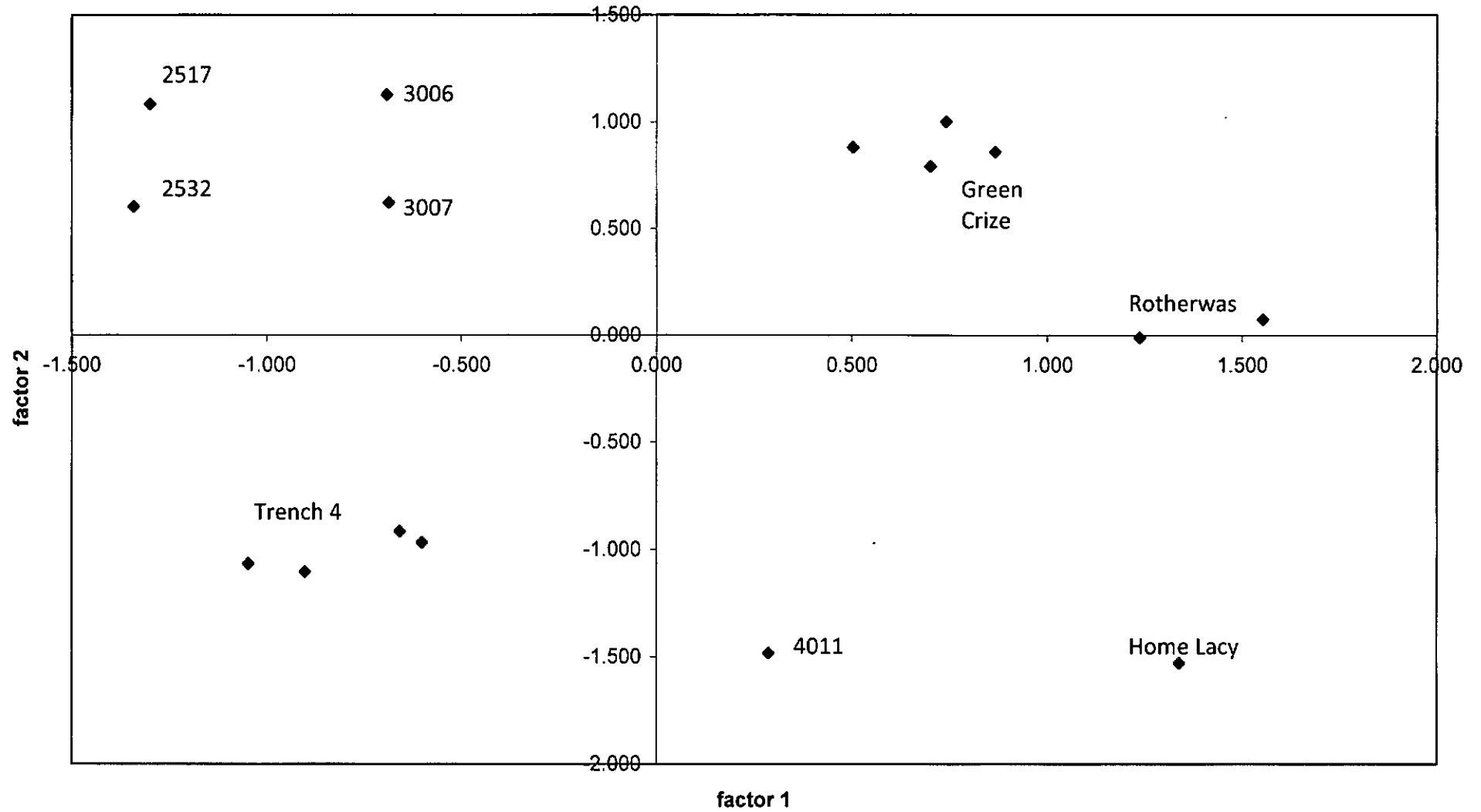

casewise factor scores: finer fraction

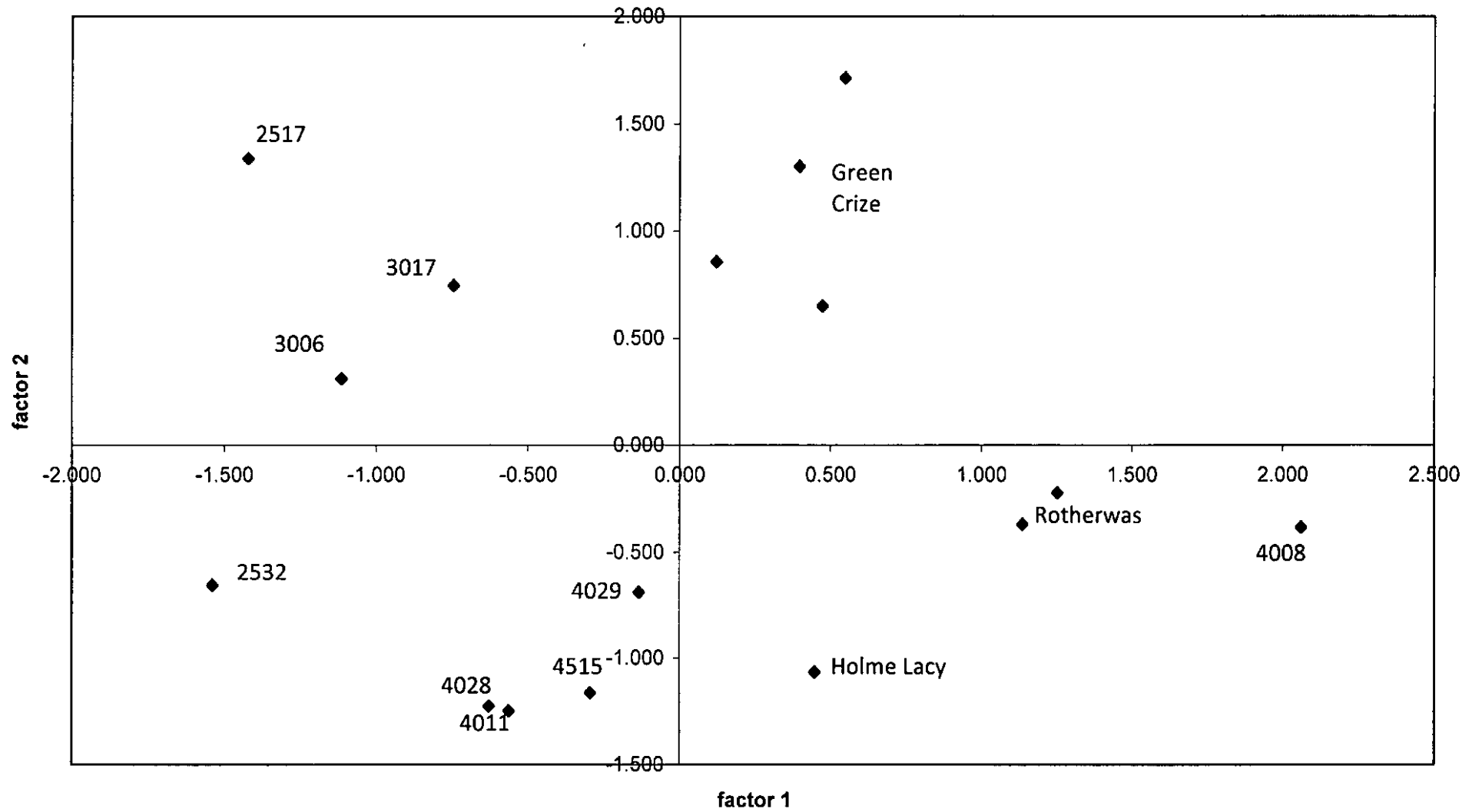

Factor Analysis Results for coarser fraction:
Factors were extracted by the Principal Component method
from the correlation matrix.

Descriptive Statistics

Variable	Mean	Std Dev.	Std Err	N
greywacke	100.938	60.052	15.013	16
silt/sh	38.125	23.258	5.814	16
sst	23.250	12.234	3.058	16
qtz	11.938	11.054	2.764	16
ig	8.063	8.918	2.229	16
ors	53.125	41.719	10.430	16

Correlation Matrix

	greywacke	silt/sh	sst	qtz	ig	ors
greywacke	1.000	0.759	0.928	0.641	0.798	0.074
silt/sh	0.759	1.000	0.629	0.946	0.513	-0.319
sst	0.928	0.629	1.000	0.525	0.748	0.233
qtz	0.641	0.946	0.525	1.000	0.490	-0.355
ig	0.798	0.513	0.748	0.490	1.000	-0.003
ors	0.074	-0.319	0.233	-0.355	-0.003	1.000

Explained Variance (Eigenvalues)

Value	Factor 1	Factor 2	Factor 3	Factor 4	Factor 5	Factor 6
Eigenvalue	3.812	1.409	0.499	0.197	0.063	0.020
% of Var.	63.526	23.488	8.320	3.285	1.043	0.338
Cum. %	63.526	87.014	95.334	98.619	99.662	100.000

Communalities

Variable	Communalities
greywacke	0.948
silt/sh	0.915
sst	0.925
qtz	0.877
ig	0.711
ors	0.844

Factor Analysis Results for finer fraction:
Factors were extracted by the Principal Component method
from the correlation matrix.

Descriptive Statistics

Variable	Mean	Std Dev.	Std Err	N
greywacke	150.438	91.856	22.964	16
silt/sh	51.813	39.585	9.896	16
sst	34.813	18.174	4.544	16
qtz	14.188	10.703	2.676	16
ig	12.750	11.556	2.889	16
ors	55.688	34.658	8.664	16

Correlation Matrix

	greywacke	silt/sh	sst	qtz	ig	ors
greywacke	1.000	0.952	0.902	0.890	0.743	0.034
silt/sh	0.952	1.000	0.872	0.909	0.578	-0.032
sst	0.902	0.872	1.000	0.756	0.554	0.095
qtz	0.890	0.909	0.756	1.000	0.638	-0.332
ig	0.743	0.578	0.554	0.638	1.000	0.074
ors	0.034	-0.032	0.095	-0.332	0.074	1.000

Explained Variance (Eigenvalues)

Value	Factor 1	Factor 2	Factor 3	Factor 4	Factor 5	Factor 6
Eigenvalue	4.149	1.133	0.523	0.149	0.030	0.016
% of Var.	69.153	18.889	8.713	2.480	0.507	0.259
Cum. %	69.153	88.041	96.754	99.234	99.741	100.000

Communalities

Variable	Communalities
greywacke	0.985
silt/sh	0.916
sst	0.839
qtz	0.961
ig	0.597
ors	0.984

Appendix 5.6: Graphical comparison of stone roundness data obtained from trenches 1-5

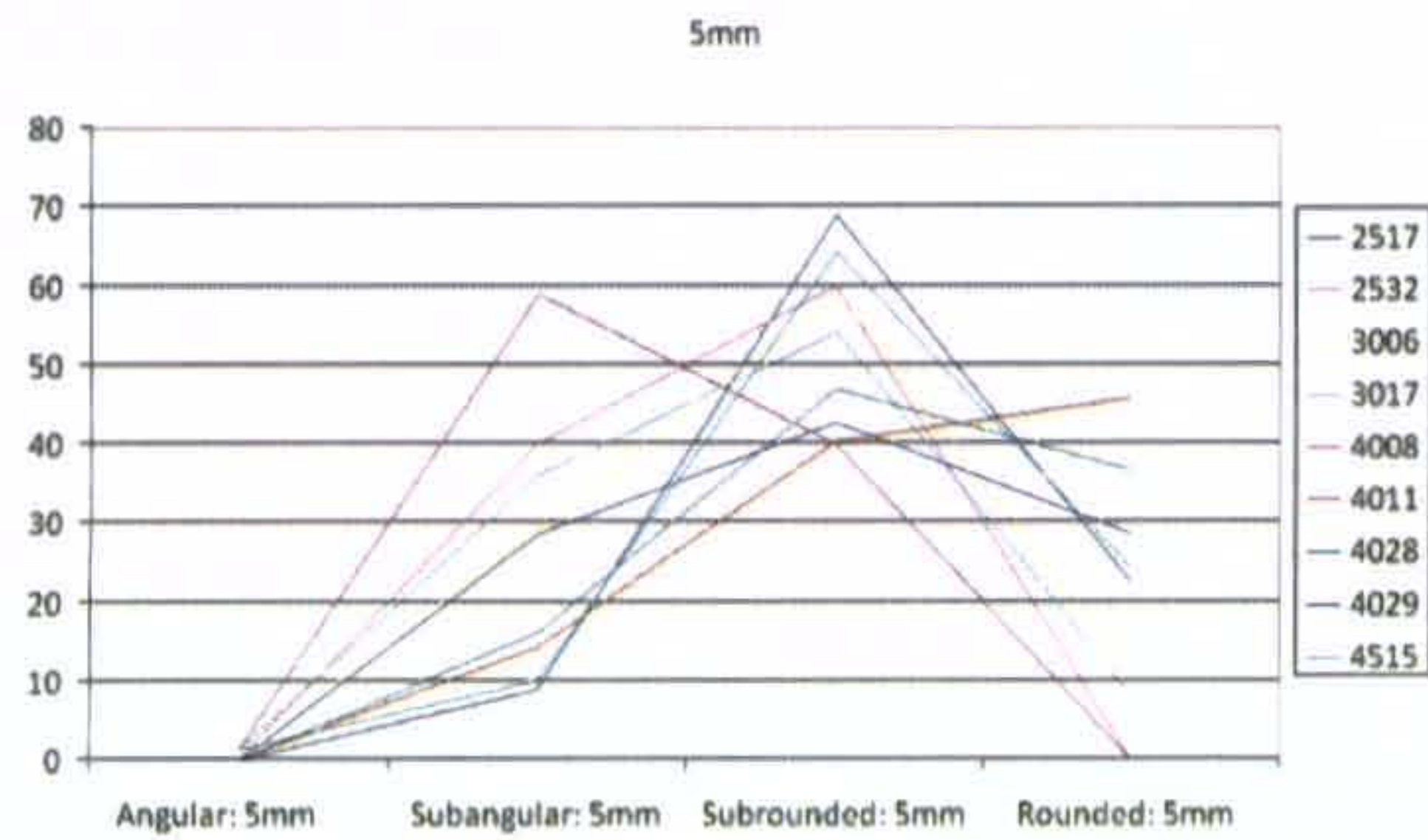
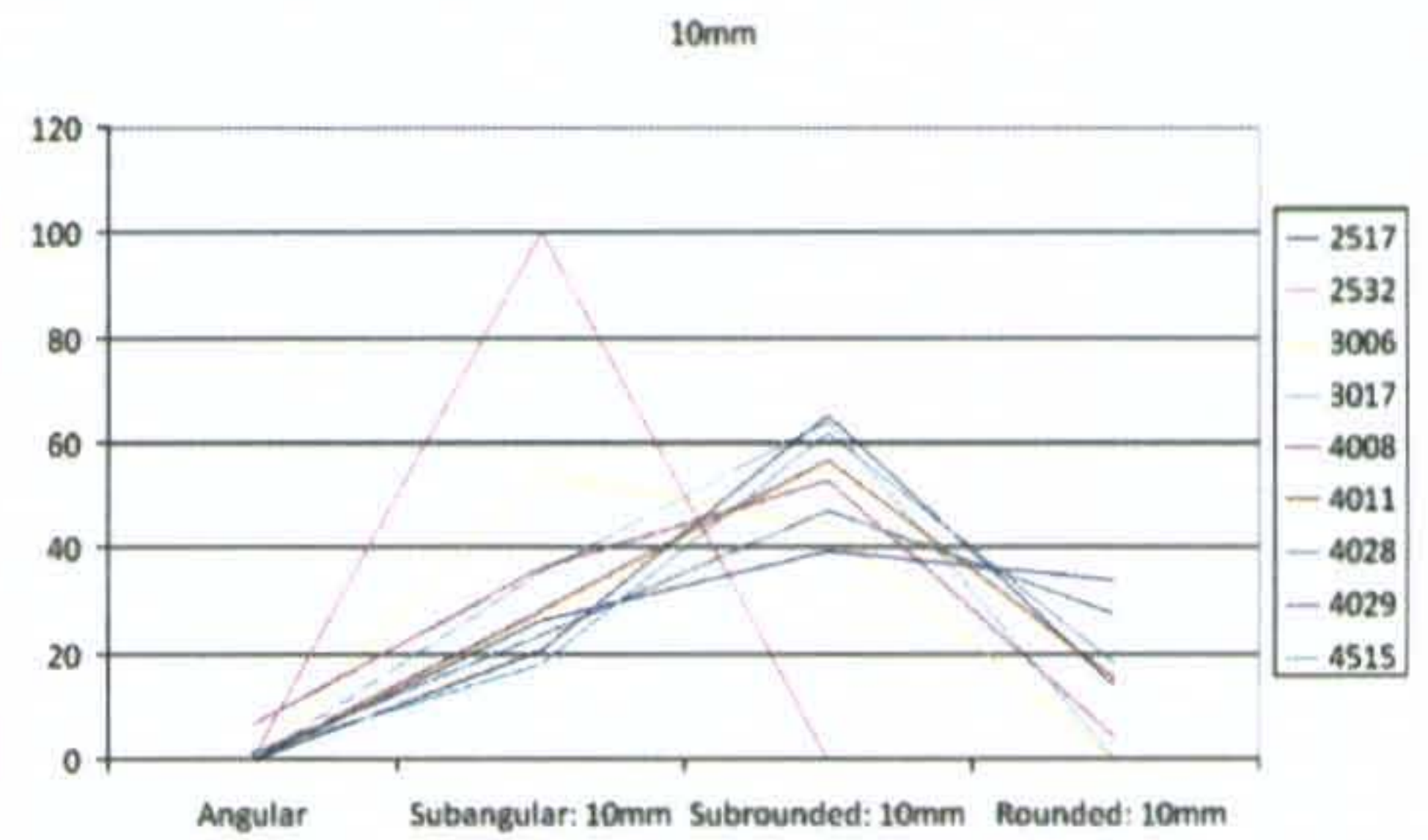
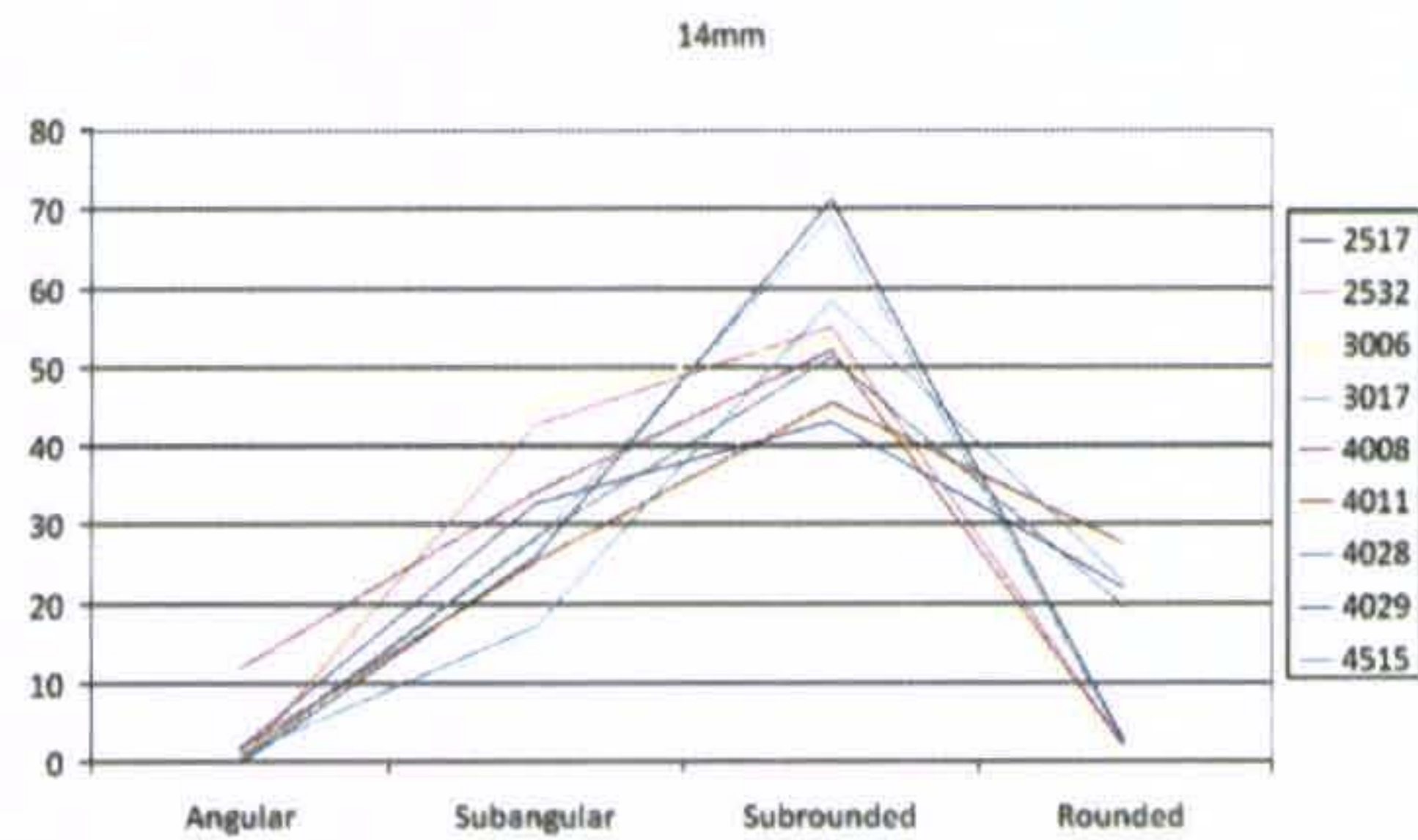
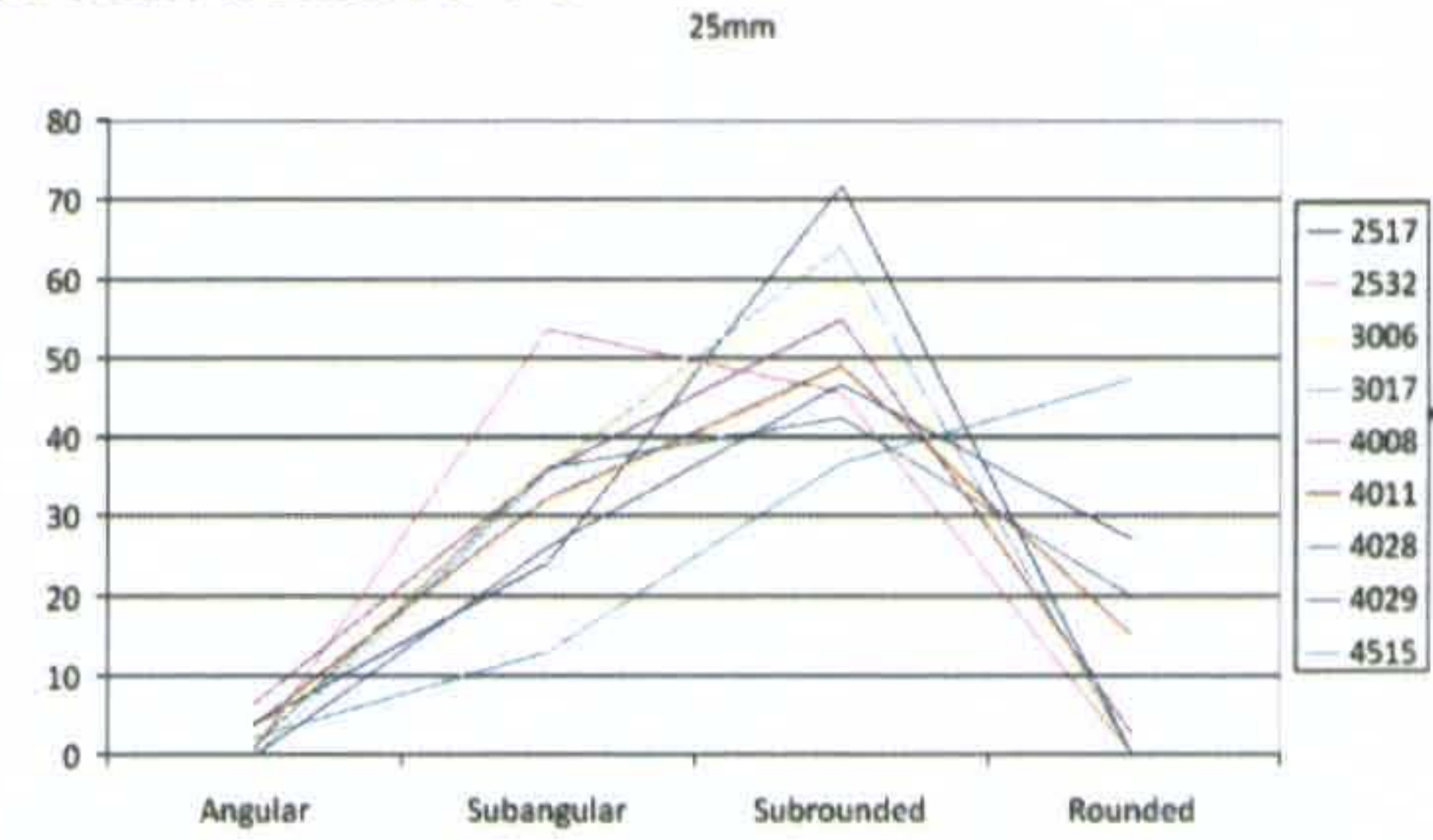
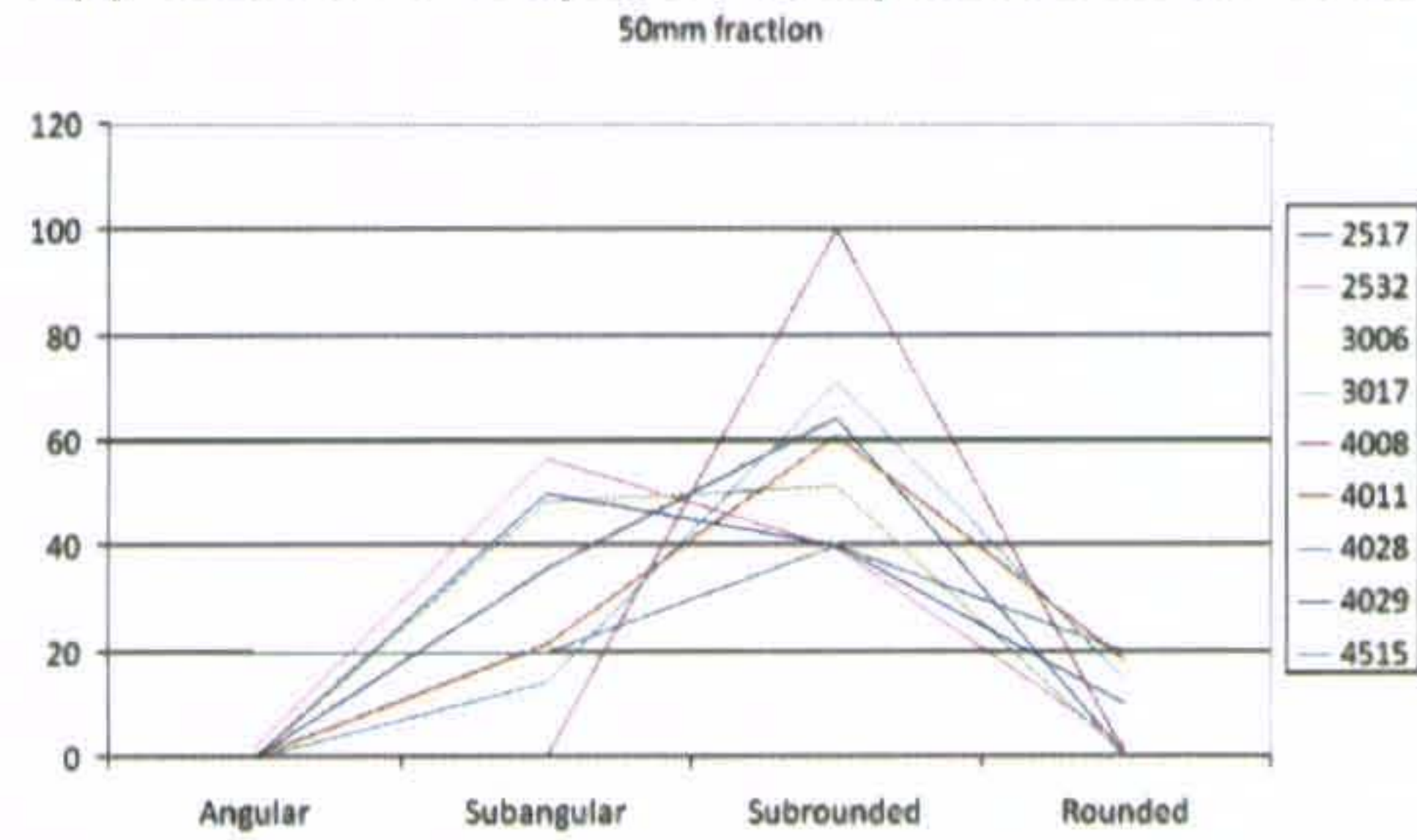

APPENDIX 6: THE FLINT ASSEMBLAGE BY TRENCH

CATEGORY TYPE	Trench 1			Trench 2			Trench 3					Trench 4					Trench 5					Grand Total	
	2511	2512	2514	3002	3005	3014	3500	3510	3513	3535	3545	4002	4003	4006	4011	4024	4501	4505	4506	4510	4514		4519
Flake		1	1		1	1	1		1	1	5	39	2		1		1	2	3			1	61
Blade												1											1
Blade-like												2	1								1		4
Wedge-shaped flake segment												1											1
Irregular waste																		1					1
Chip												21	4	1									26
Micro burin												1											1
Burin spall												1											1
Core on a flake												1											1
Tested nodule												1											1
Chisel arrowhead															1								1
End scraper	1																						1
Thumbnail scraper					1					1													2
Piercer										1										1			2
Backed knife										1													1
Edge-retouched flake												1											1
Grand Total	1	1	1	1	1	1	1	1	3	1	5	69	7	1	1	1	1	2	4	1	1	1	106

APPENDIX 7: ENVIRONMENTAL TABLES

Context	Sample	Spit/Sub-sample	Process type	Feature type	Description	Fill of	Sample volume (L)	Volume Processed (L)	Residue assessed	Flot assessed
1000	025	5 of 10	Riddle & tank				10	7	No	No
1000	023	3 of 10	Riddle & tank				10	8	No	No
1000	021	1 of 10	Riddle & tank				10	7	Yes	Yes
1000	026	6 of 10					10	0	No	No
1000	022	2 of 10	Riddle & tank				10	9	No	No
1000	024	4 of 10	Riddle & tank				10	5	No	No
1000	030	10 of 10					10	0	No	No
1000	029	9 of 10					10	0	Yes	Yes
1000	028	8 of 10					10	0	No	No
1000	027	7 of 10					10	0	No	No
2511	016	6 of 10	Riddle & tank	Surface	Lower metalled surface		10	5	Yes	Yes
2511	014	4 of 10		Surface	Lower metalled surface		10	0	No	No
2511	020	10 of 10		Surface	Lower metalled surface		10	0	No	No
2511	015	5 of 10		Surface	Lower metalled surface		10	0	No	No
2511	019	9 of 10		Surface	Lower metalled surface		10	0	No	No
2511	013	3 of 10		Surface	Lower metalled		10	0	No	No

Context	Sample	Spit/Sub-sample	Process type	Feature type	Description	Fill of	Sample volume (L)	Volume Processed (L)	Residue assessed	Flot assessed
					surface					
2511	012	2 of 10		Surface	Lower metalled surface		10	0	No	No
2511	018	8 of 10	Riddle & tank	Surface	Lower metalled surface		10	2	No	No
2511	011	1 of 10		Surface	Lower metalled surface		10	0	No	No
2511	017	7 of 10		Surface	Lower metalled surface		10	0	No	No
2517	003	3 of 10	Riddle & tank	Surface	Metalled surface		10	6	Yes	Yes
2517	005	5 of 10	Riddle & tank	Surface	Metalled surface		10	8	No	No
2517	004	4 of 10	Riddle & tank	Surface	Metalled surface		10	8	No	No
2517	009	9 of 10		Surface	Metalled surface		10	0	No	No
2517	002	2 of 10		Surface	Metalled surface		10	0	No	No
2517	007	7 of 10		Surface	Metalled surface		10	0	No	No
2517	010	10 of 10		Surface	Metalled surface		10	0	No	No
2517	151	1 of 10		Surface	Metalled surface		10	0	No	No
2517	008	8 of 10		Surface	Metalled surface		10	0	No	No
2517	006	6 of 10	Riddle & tank	Surface	Metalled surface		10	5	No	No
2529	033	1 of 2	Riddle & tank	Surface	More compact stone with depth (after removal		10	9	No	No

Context	Sample	Spit/Sub-sample	Process type	Feature type	Description	Fill of	Sample volume (L)	Volume Processed (L)	Residue assessed	Flot assessed
					2528)					
2529	034	2 of 2	Riddle & tank	Surface	More compact stone with depth (after removal 2528)		10	0	No	No
2531	031	1 of 2	Riddle & tank	Unknown	U-shaped	2530	10	0	No	No
2531	032	2 of 2	Riddle & tank	Unknown	U-shaped	2530	10	9	No	No
2532	035	2 of 10		Surface	metalled surface		10	0	No	No
2532	035	6 of 10	Riddle & tank	Surface	metalled surface		10	3	Yes	Yes
2532	035	9 of 10	Riddle & tank	Surface	metalled surface		10	3	No	No
2532	035	1 of 10		Surface	metalled surface		10	0	No	No
2532	035	8 of 10	Riddle & tank	Surface	metalled surface		10	3	No	No
2532	035	10 of 10	Riddle & tank	Surface	metalled surface		10	4	No	No
2532	035	7 of 10	Riddle & tank	Surface	metalled surface		10	4	No	No
2532	035	4 of 10		Surface	metalled surface		10	0	No	No
2532	035	5 of 10		Surface	metalled surface		10	0	No	No
2532	035	3 of 10		Surface	metalled surface		10	0	No	No
2533	036	1 of 2		Unknown	Stone dump		10	0	No	No
2533	036	2 of 2		Unknown	Stone dump		10	0	No	No

Context	Sample	Spit/Sub-sample	Process type	Feature type	Description	Fill of	Sample volume (L)	Volume Processed (L)	Residue assessed	Flot assessed
3006	002	2 of 9	Riddle & tank	Surface	Compact stone surface		10	3	Yes	Yes
3006	002	9 of 9	Riddle & tank	Surface	Compact stone surface		10	6	No	No
3006	002	4 of 9	Riddle & tank	Surface	Compact stone surface		10	0	No	No
3006	002	3 of 9	Riddle & tank	Surface	Compact stone surface		10	4	No	No
3006	002	6 of 9	Riddle & tank	Surface	Compact stone surface		10	4	No	No
3006	002	8 of 9	Riddle & tank	Surface	Compact stone surface		10	4	No	No
3006	002	1 of 9		Surface	Compact stone surface		10	0	No	No
3016	001	2 of 2		Ditch		3018	10	0	No	No
3016	001	1 of 2	Tank	Ditch		3018	10	9	Yes	Yes
3017	003	7 of 10		Surface	Metalled surface		10	0	No	No
3017	003	1 of 10	Riddle & tank	Surface	Metalled surface		10	0	No	No
3017	003	6 of 10		Surface	Metalled surface		10	0	No	No
3017	003	4 of 10	Riddle & tank	Surface	Metalled surface		10	4	Yes	Yes
3017	003	8 of 10	Riddle & tank	Surface	Metalled surface		10	4	Yes	Yes
3017	003	10 of 10	Riddle & tank	Surface	Metalled surface		10	5	No	No

Context	Sample	Spit/Sub-sample	Process type	Feature type	Description	Fill of	Sample volume (L)	Volume Processed (L)	Residue assessed	Flot assessed
3017	003	2 of 10	Riddle & tank	Surface	Metalled surface		10	0	No	No
3017	003	5 of 10	Riddle & tank	Surface	Metalled surface		10	5	No	No
3017	003	9 of 10	Riddle & tank	Surface	Metalled surface		10	5	No	No
3017	003	3 of 10	Riddle & tank	Surface	Metalled surface		10	0	No	No
3501	181			Layer	Ribbon		0	0	No	No
3513	164	5 of 10	Riddle & tank	Layer	Deposit over Ribbon		10	9	No	No
3513	164	3 of 10	Riddle & tank	Layer	Deposit over Ribbon		10	7	No	No
3513	164	7 of 10		Layer	Deposit over Ribbon		10	0	No	No
3513	164	4 of 10	Riddle & tank	Layer	Deposit over Ribbon		10	8	No	No
3513	164	10 of 10		Layer	Deposit over Ribbon		10	0	No	No
3513	164	8 of 10		Layer	Deposit over Ribbon		10	0	No	No
3513	164	1 of 10	Riddle & tank	Layer	Deposit over Ribbon		10	9	Yes	Yes
3513	164	6 of 10		Layer	Deposit over Ribbon		10	0	No	No
3513	164	2 of 10	Riddle &	Layer	Deposit over		10	10	No	No

Context	Sample	Spit/Sub-sample	Process type	Feature type	Description	Fill of	Sample volume (L)	Volume Processed (L)	Residue assessed	Flot assessed
			tank		Ribbon					
3513	164	9 of 10		Layer	Deposit over Ribbon		10	0	No	No
3514	183	8 of 10		Layer	Ribbon		10	0	No	No
3514	183	1 of 10		Layer	Ribbon		10	0	No	No
3514	183	2 of 10		Layer	Ribbon		10	0	No	No
3514	183	9 of 10		Layer	Ribbon		10	0	No	No
3514	183	10 of 10		Layer	Ribbon		10	0	No	No
3514	183	7 of 10		Layer	Ribbon		10	0	No	No
3514	183	6 of 10		Layer	Ribbon		10	0	No	No
3514	183	5 of 10		Layer	Ribbon		10	0	No	No
3514	183	4 of 10		Layer	Ribbon		10	0	No	No
3514	183	3 of 10		Layer	Ribbon		10	0	No	No
3517	163	4 of 4		Ditch		3518	10	0	No	No
3517	163	1 of 4	Tank	Ditch		3518	10	8	Yes	Yes
3517	163	2 of 4		Ditch		3518	10	0	No	No
3517	163	3 of 4		Ditch		3518	10	0	No	No
3519	162	2 of 4		Ditch		3520	10	0	No	No
3519	162	4 of 4		Ditch		3520	10	0	No	No
3519	162	1 of 4		Ditch		3520	10	8	Yes	Yes
3519	162	3 of 4		Ditch		3520	10	0	No	No
3524	150	3 of 4	Tank	Ditch	Ditch cutting ribbon	3512	10	10	No	No
3524	150	2 of 4	Tank	Ditch	Ditch cutting ribbon	3512	10	10	Yes	No
3524	150	1 of 4	Tank	Ditch	Ditch cutting	3512	10	10	Yes	Yes

Context	Sample	Spit/Sub-sample	Process type	Feature type	Description	Fill of	Sample volume (L)	Volume Processed (L)	Residue assessed	Flot assessed
					ribbon					
3524	150	4 of 4	Tank	Ditch	Ditch cutting ribbon	3512	10	10	No	No
3526	151	1 of 4		Ditch	Ditch cutting Ribbon	3512	10	0	No	No
3526	151	3 of 4		Ditch	Ditch cutting Ribbon	3512	10	0	No	No
3526	151	4 of 4		Ditch	Ditch cutting Ribbon	3512	10	0	No	No
3526	151	2 of 4		Ditch	Ditch cutting Ribbon	3512	10	0	No	No
3531	154	1 of 2	Tank	Natural			10	10	Yes	Yes
3531	154	2 of 2		Natural			10	0	No	No
3536	152	1 of 4		Ditch	Ditch cutting Ribbon	3512	10	0	No	No
3536	152	2 of 4		Ditch	Ditch cutting Ribbon	3512	10	0	No	No
3536	152	4 of 4		Ditch	Ditch cutting Ribbon	3512	10	0	No	No
3536	152	3 of 4		Ditch	Ditch cutting Ribbon	3512	10	0	No	No
3537	153	1 of 4		Ditch	Ditch cutting Ribbon	3512	10	0	No	No
3537	153	2 of 4		Ditch	Ditch cutting Ribbon	3512	10	0	No	No
3537	153	3 of 4		Ditch	Ditch cutting	3512	10	0	No	No

Context	Sample	Spit/Sub-sample	Process type	Feature type	Description	Fill of	Sample volume (L)	Volume Processed (L)	Residue assessed	Flot assessed
					Ribbon					
3537	153	4 of 4		Ditch	Ditch cutting Ribbon	3512	10	0	No	No
3538	157	2 of 4		Ditch		3512	10	0	No	No
3538	157	4 of 4		Ditch		3512	10	0	No	No
3538	157	1 of 4	Tank	Ditch		3512	10	10	Yes	Yes
3538	157	3 of 4		Ditch		3512	10	0	No	No
3539	158	4 of 4		Ditch	Ditch cutting ribbon	3512	10	0	No	No
3539	158	1 of 4		Ditch	Ditch cutting ribbon	3512	10	0	No	No
3539	158	3 of 4		Ditch	Ditch cutting ribbon	3512	10	0	No	No
3539	158	2 of 4		Ditch	Ditch cutting ribbon	3512	10	0	No	No
3545	166	4 of 7		Layer	Ribbon		10	0	No	No
3545	166	3 of 7		Layer	Ribbon		10	0	No	No
3545	166	6 of 7		Layer	Ribbon		10	0	No	No
3545	166	1 of 7	Tank	Layer	Ribbon		10	10	Yes	Yes
3545	166	2 of 7		Layer	Ribbon		10	0	No	No
3545	166	7 of 7		Layer	Ribbon		10	0	No	No
3545	166	5 of 7		Layer	Ribbon		10	0	No	No
3546	165	8 of 10		Layer	Layer over 3513 on Ribbon		10	0	No	No
3546	165	5 of 10	Riddle & tank	Layer	Layer over 3513 on Ribbon		10	10	No	No

Context	Sample	Spit/Sub-sample	Process type	Feature type	Description	Fill of	Sample volume (L)	Volume Processed (L)	Residue assessed	Flot assessed
3546	165	10 of 10		Layer	Layer over 3513 on Ribbon		10	0	No	No
3546	165	2 of 10	Riddle & tank	Layer	Layer over 3513 on Ribbon		10	10	No	No
3546	165	1 of 10	Riddle & tank	Layer	Layer over 3513 on Ribbon		10	10	Yes	Yes
3546	165	4 of 10	Riddle & tank	Layer	Layer over 3513 on Ribbon		10	10	No	No
3546	165	9 of 10		Layer	Layer over 3513 on Ribbon		10	0	No	No
3546	165	7 of 10		Layer	Layer over 3513 on Ribbon		10	0	No	No
3546	165	3 of 10	Riddle & tank	Layer	Layer over 3513 on Ribbon		10	10	No	No
3546	165	6 of 10		Layer	Layer over 3513 on Ribbon		10	0	No	No
3548	182	4 of 4		Ditch			10	0	No	No
3548	182	1 of 4		Ditch			10	0	No	No
3548	182	3 of 4		Ditch			10	0	No	No
3548	182	2 of 4		Ditch			10	0	No	No
3550	187	3 of 4		Layer	Layer below Ribbon		10	0	No	No
3550	187	2 of 4		Layer	Layer below Ribbon		10	0	No	No
3550	187	1 of 4		Layer	Layer below Ribbon		10	0	No	No

Context	Sample	Spit/Sub-sample	Process type	Feature type	Description	Fill of	Sample volume (L)	Volume Processed (L)	Residue assessed	Flot assessed
3550	187	4 of 4		Layer	Layer below Ribbon		10	0	No	No
3551	196	2 of 4		Layer			10	0	No	No
3551	196	3 of 4		Layer			10	0	No	No
3551	196	4 of 4		Layer			10	0	No	No
3551	196	1 of 4		Layer			10	0	No	No
3552	192	4 of 4		Natural	Geology below Ribbon		10	0	No	No
3552	192	3 of 4		Natural	Geology below Ribbon		10	0	No	No
3552	192	2 of 4		Natural	Geology below Ribbon		10	0	No	No
3552	192	1 of 4		Natural	Geology below Ribbon		10	0	No	No
4002	184	1 of 5		Layer	Colluvial/alluvial layer		10	0	No	No
4002	184	4 of 5		Layer	Colluvial/alluvial layer		10	0	No	No
4002	184	2 of 5		Layer	Colluvial/alluvial layer		10	0	No	No
4002	184	3 of 5		Layer	Colluvial/alluvial layer		10	0	No	No
4002	184	5 of 5		Layer	Colluvial/alluvial layer		10	0	No	No
4003	185	2 of 4		Layer	Alluvial layer		10	0	No	No
4003	185	4 of 4		Layer	Alluvial layer		10	0	No	No

Context	Sample	Spit/Sub-sample	Process type	Feature type	Description	Fill of	Sample volume (L)	Volume Processed (L)	Residue assessed	Flot assessed
4003	186			Layer	Alluvial layer		0	0	No	No
4003	185	3 of 4		Layer	Alluvial layer		10	0	No	No
4003	185	1 of 4		Layer	Alluvial layer		10	0	No	No
4005	179	0.05-0.10m		Palaeochannel			10	0	No	No
4005	179	0.20-0.25m		Palaeochannel			10	0	No	No
4005	179	0.10-0.15m		Palaeochannel			10	0	No	No
4005	179	0.15-0.2m		Palaeochannel			10	0	No	No
4006	179	0.30-0.35m	Wash-over	Palaeochannel			10	1	Yes	Yes
4006	179	0.35-0.40m		Palaeochannel			10	0	No	No
4007	179	0.5-0.55m		Palaeochannel			10	0	No	No
4007	179	0.40-0.45m		Palaeochannel			10	0	No	No
4007	179	0.55-0.60m		Palaeochannel			10	0	No	No
4007	179	0.45-0.50m		Palaeochannel			10	0	No	No
4008	161	5 of 10		Layer	Stony layer in base of channel		10	0	No	No
4008	161	1 of 10	Riddle & tank	Layer	Stony layer in base of channel		10	5	Yes	Yes
4008	179	0.60-	Wash-over	Layer	Stony layer in		10	1	Yes	Yes

Context	Sample	Spit/Sub-sample	Process type	Feature type	Description	Fill of	Sample volume (L)	Volume Processed (L)	Residue assessed	Flot assessed
		0.65m			base of channel					
4008	161	3 of 10	Riddle & tank	Layer	Stony layer in base of channel		10	8	No	No
4008	161	10 of 10		Layer	Stony layer in base of channel		10	0	No	No
4008	161	7 of 10		Layer	Stony layer in base of channel		10	0	No	No
4008	161	2 of 10	Riddle & tank	Layer	Stony layer in base of channel		10	6	No	No
4008	161	8 of 10		Layer	Stony layer in base of channel		10	0	No	No
4008	161	9 of 10		Layer	Stony layer in base of channel		10	0	No	No
4008	161	6 of 10		Layer	Stony layer in base of channel		10	0	No	No
4008	161	4 of 10		Layer	Stony layer in base of channel		10	0	No	No
4009	177	0.05-0.10m		Palaeochannel			10	0	No	No
4009	180			Palaeochannel			0	0	No	No
4009	177	0.00-0.05m	Wash-over	Palaeochannel			10	1	No	No
4009	177	0.15-0.20m	Wash-over	Palaeochannel			10	1	Yes	Yes
4009	177	0.20-0.25m		Palaeochannel			10	0	No	No

Context	Sample	Spit/Sub-sample	Process type	Feature type	Description	Fill of	Sample volume (L)	Volume Processed (L)	Residue assessed	Flot assessed
4009	177	0.10-0.15m		Palaeochannel			10	0	No	No
4009	177	0.25-0.30m		Palaeochannel			10	0	No	No
4011	160	8 of 10		Palaeochannel			10	0	No	No
4011	160	3 of 10	Riddle & tank	Palaeochannel			10	6	No	No
4011	160	9 of 10		Palaeochannel			10	0	No	No
4011	160	5 of 10	Riddle & tank	Palaeochannel			10	7	No	No
4011	160	7 of 10		Palaeochannel			10	0	No	No
4011	160	6 of 10		Palaeochannel			10	0	No	No
4011	160	2 of 10	Riddle & tank	Palaeochannel			10	7	No	No
4011	160	10 of 10		Palaeochannel			10	0	No	No
4011	160	1 of 10	Riddle & tank	Palaeochannel			10	4	Yes	Yes
4011	177	0.30-0.35m	Wash-over	Palaeochannel			10	1	No	No
4011	160	4 of 10	Riddle & tank	Palaeochannel			10	5	No	No
4018	156	2 of 2		Surface	Possible metallated surface		10	0	No	No
4018	156	1 of 2	Riddle & tank	Surface	Possible metallated surface		10	1	Yes	No
4019	155	1 of 1	Tank	Ditch			10	2	Yes	Yes

Context	Sample	Spit/Sub-sample	Process type	Feature type	Description	Fill of	Sample volume (L)	Volume Processed (L)	Residue assessed	Flot assessed
4021	159	2 of 4					10	0	No	No
4021	159	4 of 4					10	0	No	No
4021	159	3 of 4					10	0	No	No
4021	159	1 of 4	Tank				10	9	Yes	Yes
4027	190						0	0	No	No
4028	169	5 of 10		Layer	Stone deposit		10	0	No	No
4028	169	2 of 10	Riddle	Layer	Stone deposit		10	0	No	No
4028	169	3 of 10		Layer	Stone deposit		10	0	No	No
4028	169	4 of 10		Layer	Stone deposit		10	0	No	No
4028	169	9 of 10		Layer	Stone deposit		10	0	No	No
4028	169	10 of 10		Layer	Stone deposit		10	0	No	No
4028	169	6 of 10		Layer	Stone deposit		10	0	No	No
4028	169	7 of 10		Layer	Stone deposit		10	0	No	No
4028	169	1 of 10	Riddle & tank	Layer	Stone deposit		10	5	Yes	Yes
4028	169	8 of 10		Layer	Stone deposit		10	0	No	No
4029	170	6 of 10		Natural			10	0	No	No
4029	170	2 of 10	Riddle & tank	Natural			10	6	Yes	Yes
4029	170	1 of 10		Natural			10	0	No	No
4029	170	4 of 10		Natural			10	0	No	No
4029	170	7 of 10		Natural			10	0	No	No
4029	170	5 of 10		Natural			10	0	No	No
4029	170	10 of 10	Riddle & tank	Natural			10	5	No	No
4029	170	8 of 10		Natural			10	0	No	No

Context	Sample	Spit/Sub-sample	Process type	Feature type	Description	Fill of	Sample volume (L)	Volume Processed (L)	Residue assessed	Flot assessed
4029	170	3 of 10	Riddle	Natural			10	0	No	No
4029	170	9 of 10		Natural			10	0	No	No
4030	171	4 of 6		Natural			10	0	No	No
4030	171	5 of 6		Natural			10	0	No	No
4030	171	1 of 6		Natural			10	0	No	No
4030	171	3 of 6		Natural			10	0	No	No
4030	171	2 of 6		Natural			10	0	No	No
4030	171	6 of 6		Natural			10	0	No	No
4037	179	0.00-0.05m	Wash-over				10	1	Yes	Yes
4504	188	5 of 6		Linear			10	0	No	No
4504	188	1 of 6		Linear			10	0	No	No
4504	188	2 of 6		Linear			10	0	No	No
4504	188	6 of 6		Linear			10	0	No	No
4504	188	3 of 6		Linear			10	0	No	No
4504	188	4 of 6		Linear			10	0	No	No
4505	167	1 of 5	Tank	Layer	Soil patch within natural gravel		10	9	Yes	Yes
4505	167	5 of 5		Layer	Soil patch within natural gravel		10	0	No	No
4505	167	2 of 5	Wash-over	Layer	Soil patch within natural gravel		10	0	No	No
4505	167	3 of 5		Layer	Soil patch within natural gravel		10	0	No	No
4505	167	4 of 5		Layer	Soil patch within natural gravel		10	0	No	No

Context	Sample	Spit/Sub-sample	Process type	Feature type	Description	Fill of	Sample volume (L)	Volume Processed (L)	Residue assessed	Flot assessed
4506	193	6 of 6		Burnt Feature	Burnt mound		10	0	No	No
4506	193	1 of 6	Tank	Burnt Feature	Burnt mound		10	8	Yes	Yes
4506	193	2 of 6		Burnt Feature	Burnt mound		10	0	No	No
4506	193	3 of 6		Burnt Feature	Burnt mound		10	0	No	No
4506	193	4 of 6		Burnt Feature	Burnt mound		10	0	No	No
4506	193	5 of 6		Burnt Feature	Burnt mound		10	0	No	No
4507	194	4 of 6		Layer	Buried soil		10	0	No	No
4507	168	3 of 4		Layer	Buried soil		10	0	No	No
4507	194	6 of 6		Layer	Buried soil		10	0	No	No
4507	168	4 of 4		Layer	Buried soil		10	0	No	No
4507	168	2 of 4		Layer	Buried soil		10	0	No	No
4507	194	3 of 6		Layer	Buried soil		10	0	No	No
4507	194	5 of 6		Layer	Buried soil		10	0	No	No
4507	194	2 of 6		Layer	Buried soil		10	0	No	No
4507	194	1 of 6		Layer	Buried soil		10	0	No	No
4507	168	1 of 4	Tank	Layer	Buried soil		10	9	Yes	Yes
4508	172	1 of 4	Tank	Natural	Colluvium		10	8	Yes	Yes
4508	172	3 of 4		Natural	Colluvium		10	0	No	No
4508	172	4 of 4		Natural	Colluvium		10	0	No	No
4508	172	2 of 4		Natural	Colluvium		10	0	No	No
4514	174	2 of 6	Wash-over	Surface	Large cobble surface		10	0	No	No
4514	174	3 of 6		Surface	Large cobble surface		10	0	No	No
4514	174	4 of 6		Surface	Large cobble surface		10	0	No	No

Context	Sample	Spit/Sub-sample	Process type	Feature type	Description	Fill of	Sample volume (L)	Volume Processed (L)	Residue assessed	Flot assessed
4514	174	5 of 6		Surface	Large cobble surface		10	0	No	No
4514	174	6 of 6		Surface	Large cobble surface		10	0	No	No
4514	174	1 of 6	Riddle & tank	Surface	Large cobble surface		10	5	Yes	Yes
4515	191	3 of 6		Surface	Compact metalled surface		10	0	No	No
4515	191	4 of 6		Surface	Compact metalled surface		10	0	No	No
4515	197	1 of 6		Surface	Compact metalled surface		10	0	No	No
4515	197	5 of 6		Surface	Compact metalled surface		10	0	No	No
4515	197	2 of 6		Surface	Compact metalled surface		10	0	No	No
4515	197	6 of 6		Surface	Compact metalled surface		10	0	No	No
4515	191	1 of 6	Riddle	Surface	Compact metalled surface		10	0	No	No
4515	197	4 of 6		Surface	Compact metalled surface		10	0	No	No
4515	197	3 of 6		Surface	Compact metalled surface		10	0	No	No
4515	191	5 of 6		Surface	Compact metalled surface		10	0	No	No

Context	Sample	Spit/Sub-sample	Process type	Feature type	Description	Fill of	Sample volume (L)	Volume Processed (L)	Residue assessed	Flot assessed
4515	191	2 of 6	Riddle	Surface	Compact metallised surface		10	0	No	No
4515	191	6 of 6		Surface	Compact metallised surface		10	0	No	No
4516	173	3 of 4		Unknown	Cut through Ribbon	4517	10	0	No	No
4516	173	2 of 4		Unknown	Cut through Ribbon	4517	10	0	No	No
4516	173	4 of 4		Unknown	Cut through Ribbon	4517	10	0	No	No
4516	173	1 of 4		Unknown	Cut through Ribbon	4517	10	0	No	No
4519	175	3 of 3		Pit		4518	10	0	No	No
4519	175	1 of 3	Tank	Pit		4518	10	9	Yes	Yes
4519	175	2 of 3		Pit		4518	10	0	No	No
4520	189	5 of 6		Natural	Natural gravel (glacial?)		10	0	No	No
4520	189	1 of 6		Natural	Natural gravel (glacial?)		10	0	No	No
4520	189	2 of 6		Natural	Natural gravel (glacial?)		10	0	No	No
4520	189	4 of 6		Natural	Natural gravel (glacial?)		10	0	No	No
4520	189	6 of 6		Natural	Natural gravel (glacial?)		10	0	No	No
4520	189	3 of 6		Natural	Natural gravel		10	0	No	No

Context	Sample	Spit/Sub-sample	Process type	Feature type	Description	Fill of	Sample volume (L)	Volume Processed (L)	Residue assessed	Flot assessed
					(glacial?)					
4531	198	5 of 6		Layer	Layer burning & charcoal		10	0	No	No
4531	198	1 of 6	Tank	Layer	Layer burning & charcoal		10	8	Yes	Yes
4531	198	3 of 6		Layer	Layer burning & charcoal		10	0	No	No
4531	198	6 of 6		Layer	Layer burning & charcoal		10	0	No	No
4531	198	4 of 6		Layer	Layer burning & charcoal		10	0	No	No
4531	198	2 of 6		Layer	Layer burning & charcoal		10	0	No	No
4534	200	5 of 6		Layer	Middle surface ribbon		10	0	No	No
4534	200	4 of 6		Layer	Middle surface ribbon		10	0	No	No
4534	200	3 of 6		Layer	Middle surface ribbon		10	0	No	No
4534	200	6 of 6		Layer	Middle surface ribbon		10	0	No	No
4534	200	2 of 6		Layer	Middle surface ribbon		10	0	No	No
4534	200	1 of 6		Layer	Middle surface ribbon		10	0	No	No
4535	195	2 of 6		Layer	Band of charcoal		10	0	No	No

Context	Sample	Spit/Sub-sample	Process type	Feature type	Description	Fill of	Sample volume (L)	Volume Processed (L)	Residue assessed	Flot assessed
					within 'burnt mound' pit					
4535	195	1 of 6		Layer	Band of charcoal within 'burnt mound' pit		10	0	No	No
4535	195	6 of 6		Layer	Band of charcoal within 'burnt mound' pit		10	0	No	No
4535	195	4 of 6		Layer	Band of charcoal within 'burnt mound' pit		10	0	No	No
4535	195	3 of 6		Layer	Band of charcoal within 'burnt mound' pit		10	0	No	No
4535	195	5 of 6	Tank	Layer	Band of charcoal within 'burnt mound' pit		10	10	Yes	Yes
8506	199									

0 0 No No

Env Table 1; List of environmental samples

Context	Sample	Spit/Sub-sample	large mammal	small mammal	mollusc	insect	charcoal	charred plant	waterlogged plant	Comment
1000	21					occ*		occ	abt*	occ coal, charred organic material
2511	16		occ			occ*	occ		abt*	occ pot
2517	3		occ				occ		abt*	occ pot, ?tile
2532	35		mod		occ		occ	occ	abt*	occ ?Fe slag
3006	2		occ				occ	occ	abt*	?vitrified material
3016	1		occ				occ	occ	abt*	occ vitrified material
3017	3	Bucket 4/10	occ						occ-mod*	occ coal
3017	3	Bucket 8/10	occ				occ		abt*	occ Fe concretions
3513	164		occ				mod		abt*	occ Fe concretions
3517	163						mod-abt		abt*	occ Fe concretions, quartz
3519	162						occ		abt*	occ burnt stone/
3524	150	Bucket 1/4					occ-mod			occ Fe concretions
3524	150	Bucket 2/4	occ				occ			occ cracked stone
3531	154						occ		abt*	occ cracked stone
3538	157						abt	occ	abt*	occ cracked stone
3545	166		occ				occ-mod		abt*	mod cracked stone
3546	165						occ		abt*	occ Fe concretions
4006	179	0.30-0.35m					occ			
4008	161		occ				occ		occ*	occ ?flint waste, burnt stone, glass, quartz
4008	179	0.60-0.65m					occ			

Context	Sample	Spit/Sub-sample	large mammal	small mammal	mollusc	insect	charcoal	charred plant	waterlogged plant	Comment
4009	177	0.15-0.20m					occ		occ*	
4011	160		occ				occ		occ-mod*	
4011	177	0.30-0.35m					occ		occ*	
4018	156						occ			
4019	155						occ-mod		abt*	
4021	159						occ		mod-abt*	
4028	169		occ				occ		abt*	occ Fe concretions
4029	170						occ-abt		abt*	
4037	179	0.00-0.05m					occ		occ*	
4505	167		occ			occ*	occ		occ*	occ flint
4506	193						occ-mod		occ*	occ cracked stone
4507	168		occ			occ*	abt	occ	abt*	occ flint, burnt bone, quartz
4508	172			occ			occ		mod*	occ Fe concretions
4514	174						occ		abt*	occ Fe concretions, quartz
4519	173						occ	occ	abt*	occ-mod cracked stone
4531	198						abt		abt*	abt cracked stone
4535	195						mod-abt		abt*	occ cracked stone

Env Table 2: Summary of environmental remains

occ = occasional, mod = moderate, abt = abundant, * = modern, intrusive

Context	Sample	Spit/Sub-sample	large mammal	small mammal	charcoal	charred plant	mollusc	pottery	ceramic building material	flint	burnt stone	iron slag/concretions	coal	comment
1000	21												0.3g	charred organic material 0.1g
2511	16		13.2g		0.1g			5.2g			625g			
2517	3		7.2g		0.5g			7.7g	925g		88.9g			
2532	35		94.7g		0.2g	0.1g	0.1g				9.7g	0.4g	occ	
3006	2		6.9g		0.3g	occ		0.6g					0.1g	
3017	3	Bucket 4/10	0.1g										0.1g	
3017	3	Bucket 8/10			0.1g							0.3g		Charcoal moderately abundant in flot
3513	164		0.1g		0.1g						17g	0.8g		Charcoal moderately abundant in flot
3524	150	Bucket 1/4			0.3g							0.5g		
3546	165				0.1g							5.5g		
4008	161		1.3g		0.6g					0.1g	123.3g			glass 0.1g
4011	160		0.1g		occ						22.9g			
4018	156				0.1g						5.9g			
4028	169		0.1g		0.1g						2.5g	5.5g		

4029	170				0.1g						33.8g			Charcoal relatively abundant in flot
4514	174				<0.1g						42.8g	1.9g		

Env Table 3: Weight of sorted remains from selected compact stone layers

Note: weight (g) recorded for remains sorted from fractions >2mm

Latin name	Family	Common name	Habitat	3016	3538	4507	4519
<i>Uncharred plant remains</i>							
Poaceae sp indet culm node	Poaceae	grasses	AF				+
<i>Chenopodium album</i>	Chenopodiaceae	fat hen	AB				+
unidentified herbaceous fragments	unidentified			+++		+++	+++
<i>Charred plant remains</i>							
<i>Triticum dicoccum/spelta</i> grain	Poaceae	emmer/spelt wheat	F	+	+		
cf Cereal sp indet grain fragment	Poaceae	cereal	F			+	
cf Poaceae sp indet grain	Poaceae	grass	AF				+

Env Table 4: Charred plant remains

Habitat	
Quantity	
A= cultivated ground	+= 1 - 10
B= disturbed ground	++ = 11-50
C= woodlands, hedgerows, scrub etc	+++ = 51 -100
D = grasslands, meadows and heathland	++++ = 101+
E = aquatic/wet habitats	
F = cultivar	

Latin Name	Family	Common Name(s)	0.04m <176> (4009)	0.32m <176> (4011)	0.04m <190> (4037)	0.64m <190> (4007)	'Ribbon' - 0.02m	'Ribbon' - 0.06m
<i>Alnus glutinosa</i>	Betulaceae	alder				1		
<i>Betula</i>	Betulaceae	birch					1	
<i>Fraxinus excelsior</i>	Oleaceae	ash					1	
<i>Quercus</i>	Fagaceae	oak			1	4		1
<i>Corylus avellana</i> -type	Betulaceae	hazel			1	2		
<i>Salix</i>	Salicaceae	willow			1	2		
<i>Calluna vulgaris</i>	Ericaceae	heather						
Poaceae undiff	Poaceae	grass	8	3	5	36	5	37
<i>Cerealia indet</i>	Poaceae	indeterminate cereal						2
<i>Avena/ Triticum</i> -type	Poaceae	oat/wheat						1
<i>Achillea</i> -type	Asteraceae	yarrows/ chamomiles						1
Apiaceae	Apiaceae	carrot family			1	1		
Caryophyllaceae	Caryophyllaceae	pink family				2		1
Chenopodioideae	Amaranthaceae	goosefoot subfamily			1			1
Chrysosplenium	Saxifragaceae	golden-saxifrages						1
<i>Cichorium intybus</i> -type	Lactuceae	chicory/dandelion		1		1		1
Cyperaceae undiff	Cyperaceae	sedge				5		2
<i>Filipendula</i>	Rosaceae	meadowsweet				1		
Lactuceae undiff	Asteraceae	chicory/dandelion/sow-thistle	1		2	8	1	2
<i>Plantago lanceolata</i>	Plantaginaceae	ribwort plantain	1		3	8	1	6
<i>Ranunculus acris</i> -type	Ranunculaceae	meadow buttercup	1			3		1

Latin Name	Family	Common Name(s)	0.04m <176> (4009)	0.32m <176> (4011)	0.04m <190> (4037)	0.64m <190> (4007)	'Ribbon' - 0.02m	'Ribbon' - 0.06m
Rosaceae	Rosaceae	Rose family	1			2		1
<i>Rumex acetosella</i>	Polygonaceae	sheep's sorrel						1
<i>Saxifraga granulata</i> -type	Saxifragaceae	meadow saxifrage					1	
Saxifragaceae	Saxifragaceae	saxifrage family				2		
<i>Solidago virgaurea</i> -type	Asteraceae	daisies/ goldenrods			1	2		1
<i>Urtica dioica</i>	Urticaceae	stinging nettle	2		2	1	1	4
cf <i>Urtica urens</i>	Urticaceae	small nettle				1		
		TLP Grains counted	14	4	18	82	11	64
cf <i>Nuphar</i>	Nymphaeaceae	yellow water-lily			1			
<i>Polypodium</i>	Polypodiaceae	polypody				1		
<i>Pteridium aquilinum</i>	Dennstaedtiaceae	bracken			2	3	1	2
<i>Pteropsida</i> (mono) indet		ferns	2		1			

Env Table 5: Pollen results