

CANAL BRIDGE

BISHOP'S BRIDGE ROAD

London W2, City of Westminster

Preliminary Archaeological Report

Malcolm T Tucker
Engineering Historian & Archaeologist
9 Blythwood Road
London N4 4EU



English Heritage
Historic Buildings and Areas Research Department, London Team
Reports and Papers B/019/2003
October 2003

CONTENTS

1. Introduction and Nature of Request
2. General Description
3. Detailed Description
4. General Condition of the Ironwork
5. Considerations Affecting Dismantling
6. Outline of Historical Significance of the Ironwork
7. References
8. Measured Drawings
9. Photographs

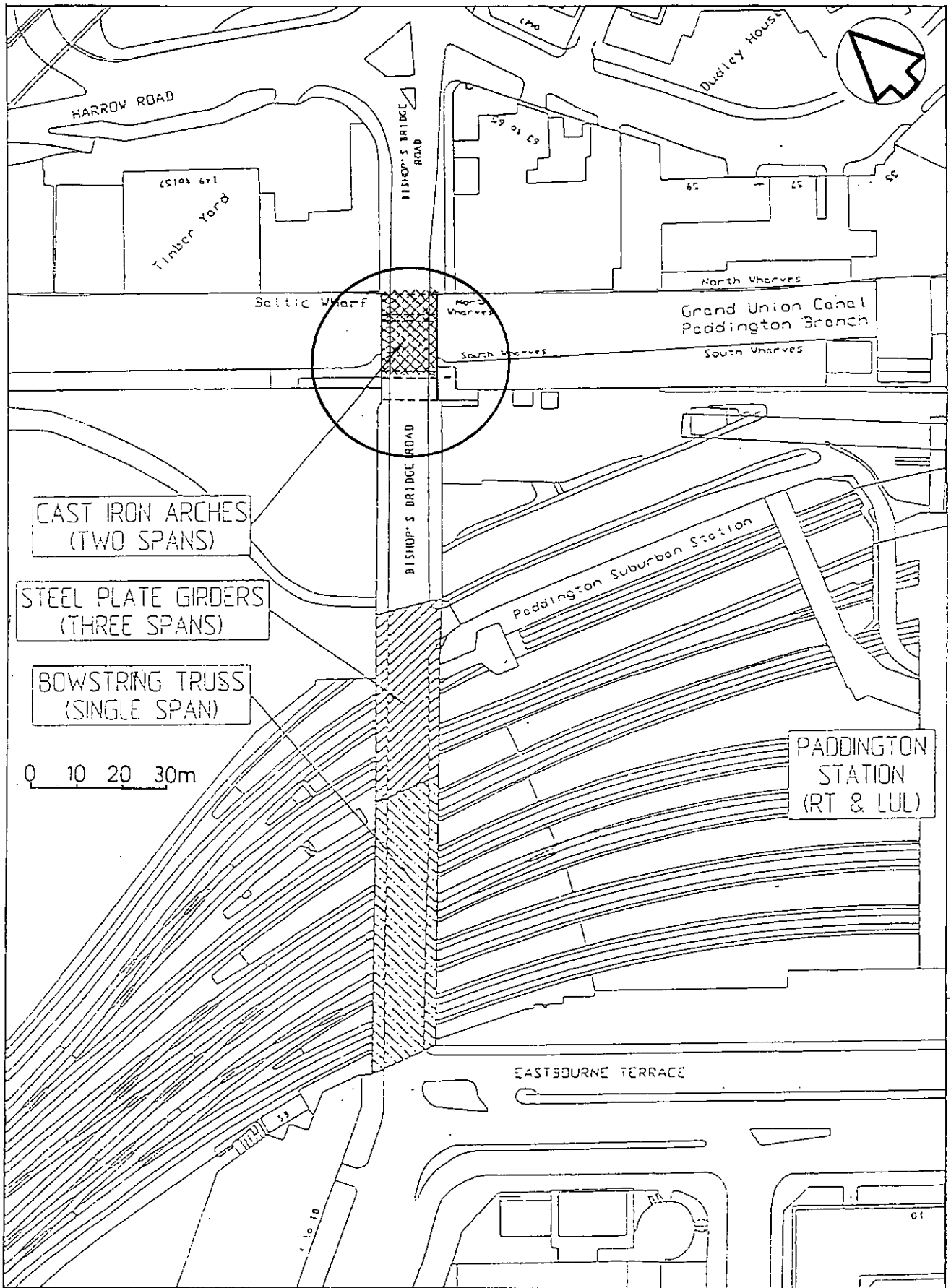

LOCATION PLAN

(Hyder Consulting Ltd, Bishop's Bridge Detailed Assessment, 1997)

1. INTRODUCTION AND NATURE OF REQUEST

- 1.1 The canal bridge at Bishop's Bridge Road, London W2, was built in 1838 to the design of IK Brunel, as part of a road viaduct adjoining the Paddington terminus of the Great Western Railway⁽¹⁾. It is a rare example of Brunel's use of cast iron in a bridge structure.
- 1.2 The bridge spans the Paddington Basin arm of the Grand Union (formerly Grand Junction) Canal at TQ 2648.8159. There are two unequal spans over the waterway, of shallow-arched cast-iron girders with cast-iron soffit plates supporting a mass concrete deck, brick fascia walls and stone cornice. A land arch, in brickwork, was incorporated in the modelling to give a symmetrical, 3-span appearance
- 1.3 This section of canal was until recently inaccessible to towpath walkers, while the bridge parapets were wholly rebuilt in the 1900s, so that, hidden from view, the bridge has previously not been recognised as historically significant. It is not listed. The bridge is to be replaced in 2004 as part of a major reconstruction and widening of the viaduct. English Heritage has been investigating means of relocating the structure, by dismantling it or moving it bodily.
- 1.4 This report describes the materials of construction, the manner in which the ironwork has been put together, and its condition. Its purpose is to inform the preparation of schemes to salvage the bridge's structure, while also providing an archaeological record. It has been written following opening up of the structure from above, using two trial pits excavated in the carriageway, and after inspection of the exposed underside of the ironwork, partly from a canal boat. Subsequently, use has been made of temporary staging erected for a separate photogrammetric survey by English Heritage.
- 1.5 The report has been produced by Malcolm T Tucker, MA CEng MICE, consultant engineering historian and industrial archaeologist, on behalf of the London Team of the Historic Buildings and Areas Research Department of English Heritage.

Origin of Request: Susie Barson, London Team, H.B.A.R.D.
Date of Request: 4 August 2003
Site Visits: 11, 20, 21, 26 and 28 August, 9 and 16 October 2003
Date of Report: Initial Report 4 September 2003, Final Report 31 October 2003
File Name: H.B.A.R.D. (London), Reports & Papers B/019/2003
©English Heritage 23 Savile Row, London W1S 2ET

Malcolm T Tucker
Engineering Historian and Archaeologist
9 Blythwood Road
London N4 4EU

2. GENERAL DESCRIPTION

- 2.1 The crossing of the Canal is at the highest point of the road viaduct, approximately 180 metres long, that Brunel designed in 1837-8 to carry a new public road across the site of the Great Western Railway terminus at Paddington⁽²⁾. To limit the gradient of the northern approach from the Harrow Road, the constructional depth over the canal needed to be minimised, while the canal's existing navigable width was to be respected⁽³⁾. Brunel's solution to these problems was to use cast-iron girders rather than brick arches, to maintain adequate headroom throughout, and to introduce an intermediate pier, standing in the channel, to reduce the lengths of span and their structural depth. The two spans over the canal had to be made unequal, a 35-foot (10.7m) main span to accommodate the towpath and two barges passing, and a 16-foot (4.9m) side span for the use of barges berthing at wharves on the offside.
- 2.2 To maintain a symmetrical appearance in the elevations, simulating three spans rather than two, an adjacent 16-foot (4.9m) span of the viaduct over dry land was also incorporated in the architectural treatment, although it is constructed as a brick barrel vault behind the facades. Brunel's choice of cast iron was unusual, and it is the detailing of the surviving ironwork which provides special importance to this bridge, but his architectural handling of a difficult situation is also of interest.
- 2.3 The length of the three spans, over the outer faces of the abutment piers, is about 27.7 metres (91ft). The width of the bridge over the fascia walls is 12.7 metres (41ft 9in), giving a clear width for the present carriageway and two footpaths of 11.8 metres (38ft 9in). This approximates to the 40 feet agreed with the Paddington Vestry in 1837⁽⁴⁾, and is narrower than the main part of the viaduct. There is a clear headroom of 1.88 metres (6ft 2in) above the present towpath at the springing of the girders, and a headroom of approximately 3 metres (10ft) at the crown of the main arch above the (slightly variable) canal water level.
- 2.4 The substructure of the bridge is of London stock brickwork and an early Great Western Railway drawing shows that the piers supporting the navigation spans are built hollow, with arched voids, an unusual sophistication⁽⁵⁾. They stand on broad, spread footings of brickwork. There are pointed cutwaters, capped with massive Millstone Grit blocks above the water level, at the ends of the pier that divides the navigation span.
- 2.5 The girders are solidly embedded in mass concrete (see 3.18), which fills the deck up to the road metalling and had to be carefully broken out for the trial pits. Except in the edge bays, where there are brick jack-arches, the concrete is supported on arched, cast-iron 'soffit plates', which differ between the two spans.
- 2.6 Both the unusual "banana" – or sickle - shaped profile of the main girders and their bulb-tee cross section are hidden from view within the bridge. They are described in detail in 3.2 to 3.5 below. Otherwise, the cast-iron construction of the two navigation spans is revealed on the underside of the bridge. The shallow-arched lower flanges of the eleven cast-iron girders, spaced at 4-foot (1.22m) centres, spring from cast-iron seating plates on the tops of the piers. The cast-iron soffit plates, repeating the shallow-arched convention, span the spaces between the girder flanges to support the mass-concrete filling of the bridge deck. In the longer span, these plates are arched longitudinally, resting on crossbeams between the girders at 5-foot (1.53m) intervals. In the shorter span, the plates are arched transversely and supported directly by the girder flanges, but they also have a longitudinal curvature to follow the girders. (see 3.12 to 3.15 below)

- 2.7 The main girders are spaced apart by the crossbeams and held in place by staggered tie bars, within the mass concrete filling, as described more fully in 3.8 to 3.11. Except for the tie bars, there are no tensile fastenings in the ironwork, but iron cement and some wedges are used for tight fit.
- 2.8 In the two edge bays in both spans, brick jack arches are used in place of the cast-iron soffit plates. They are laid in Roman cement, for strength, and, although tidily executed, they were formerly rendered on the soffit. Whether this variation was to provide for service trenches is not as yet known.
- 2.9 The architectural treatment was based on established classical practices in masonry, around the "triumphal arch" model of a main span and two small side spans. In keeping with this convention, the cast-iron girders were made arched on their underside. For propriety's sake, and to disguise the difference in the materials of the three arches, the edge girders are concealed from view, except for their lower flanges, by fascia walls in stock brickwork. These incorporate non-structural three-ring brick arches which follow the shallow segmental curves of the lower flanges and are repeated structurally in the third arch. The two intermediate piers, each 6 feet (1.8m) wide, are extended upwards as pilasters, projecting by one brick, and the abutment piers project by 3 feet 4 inches (1.0m) beyond the fascia at each corner. The brickwork carried a dressed freestone cornice, possibly of Portland stone, and this remains in place on the south-east face. The contemporary Great Western Railway drawing⁽⁶⁾ shows balustrades probably of cast-iron panels, between the piers. But these were replaced, probably in the 1900s, by high, solid parapet walls of red engineering brickwork. Also probably in the 1900s, the end faces of the pier dividing the navigation spans were refaced with blue-brindled engineering bricks.
- 2.10 The essential relationship of the third arch to the whole composition cannot currently be appreciated because of a building, now partly demolished, that was built in front of its south-east face, while its other face is temporarily obscured by a hoarding. The third arch was, from the start, closed off by walls, blind except for a central opening, in order to conceal the disparate, but functionally appropriate, barrel vault structure within.
- 2.11 In this report, the bridge has been called the Canal Bridge at Bishop's Bridge Road. The road, laid out at the time of building of the viaduct, was originally named Bishop's Road, having taken the place of a footpath called Bishop's Walk, and it was renamed Bishop's Bridge Road by the London County Council in 1937 (to distinguish it from other Bishop's Roads). The Ordnance Survey continues to name the viaduct Bishop's Road Bridge, but the canal bridge is only a small part of this. The previous footpath bridge was called the Wooden Bridge, and there is probably little historic basis for the name "Bishop's Bridge" that has been used for the viaduct by some modern writers⁽⁷⁾. "Bishop's Road Canal Bridge" may be an appropriate name for further use.

3. DETAILED DESCRIPTION

- 3.1 The detailed investigation of parts of the iron superstructure has generally confirmed and amplified both the general arrangement shown on the contemporary Great Western Railway drawing of the bridge⁽⁶⁾ and the details of the typical girders recorded, with dimensions, in a Brunel notebook⁽⁹⁾. The opening-up of the structure from above was confined to the internal bays of the bridge, and the details of the edge bays and edge girders, visible only from the underside, remain conjectural (see 3.16 and 3.17).

Girders

- 3.2 The typical girders of the main span clear span 10.73 metres (35ft 2in) between the seating plates, and the lower flange rises approximately 590 millimetres (1ft 11in) in a shallow circular arc that subtends an angle of 25°. Beyond the springing line at each end, the flange turns horizontal and widens out to bear on the level surface of the seating plates.

The bulbed top of the girder rises in a steeper, compound curve (with decreasing radius near the ends), giving a distinctive banana-like side elevation. Brunel's notebook shows a mid-span depth of 2 feet 2 inches (660mm), or 1/16 of the clear span. With their shallow rise and level ends, these girders are conceived structurally as beams, not arches, although there may be incidental arching and stiffening action through the mass concrete deck.

- 3.3 The typical girders of the side span, clear-spanning 4.87 metres (16ft) between the seating plates, have a similar but less elongated side profile, with a more uniform top curvature. The rise of the lower flanges is approximately 430 millimetres (1ft 5in), subtending an arc of 40°, and the mid-span depth measures approximately 530 millimetres (1ft 9in), or 1/9 of the clear span.
- 3.4 The girders have an unusual cross section, a heavy 'bulb-tee', comprising a lower flange (which is steeply tapering in the main span but non-tapering in the smaller span), a thick vertical web and a very large, solid bulb in place of an upper flange. In the main span, the bulb shape is semicircular in its upper half but straight-tapered down to the web, so that there is a 'keel' along each side face. The top bulb turns down at each end to meet the bearing flange. The flange is slightly wider and thicker at the bearing. In the longer span only, there is a web-stiffener above the bearing.
- 3.5 In the main span, the flange is 250 millimetres (nominally 10in) wide and 45 millimetres (1¾in) deep at the edges, but 90 millimetres deep at the middle, the bulb is about 185 millimetres (just over 7in) wide and 203 millimetres (8in) deep, and the web is about 65 millimetres (2½in) thick. In the smaller span, the flange is 203 millimetres (8in) wide and a constant 45 millimetres (1¾in) deep, the bulb is 125 millimetres (5in) wide and 160 millimetres (6¼in) deep and the web is about 45 millimetres (1¾in) thick. In both cases, the girders are at 1.2 metres (4ft) nominal centres. The cross section in the main span is not increased proportionally to the much greater span, so that the longer girders are clearly working much harder than those of the smaller span in their bending stresses under a distributed loading. More remarkable, however, are the sizes of the bulbs, which in both cases have about one-and-a-half times the cross-sectional areas of the lower flanges. Since cast iron is weak in tension, it was normal practice to make the lower flange of a girder much bigger than the upper flange or bulb – and after extensive tests Hodgkinson had recommended a factor of six. This raises a question of Brunel's familiarity with cast iron, discussed in Section 6 below.

Seatings

- 3.6 The seating plates have the profile of a 'Z' on its side, with a downstand rib at the front and an upstand rib at the back, to spread the load laterally. They extend along the front edges of the piers across the full width of the bridge, and they are straight-jointed midway between each pair of girders except at the edges, where they are extra long to support two girders. They are bedded on the brickwork in Roman cement (which was quick setting and of similar strength to well-burnt stock bricks).

- 3.7 The girders are probably bedded onto the seating plates with a coating of iron cement to take up irregularities in the castings. But this is difficult to discern because of the hardness of the filling. Although the springing points of the girders are raised typically 10 millimetres above the front edge of the seating plates, no gap is generally visible and no impression could be made on the suspected filling with a light hammer and chisel, except to raise a metallic lustre. This may suggest that there are iron plates used as packings, yet the surfaces are smooth and rounded, without signs of edges. It is possible that the iron cement used here has a graded aggregate with large iron particles. Further exploration with an abrasive disc may be appropriate.

Crossbeams

- 3.8 The main span girders are spaced apart within the concrete filling of the deck, by cast-iron diaphragms or 'crossbeams', and they are tied together with wrought-iron tie bars. Each tie bar connects one pair of girders, through holes in the webs, with a hexagonal nut securing each end beyond the web, tightened against a pack of washers. A succession of such tie bars, staggered in plan position, connects across the width of the bridge. There are six such crossbeams in each girder bay of the main span, spaced 5 feet (1.5m) apart, and there is a tie bar midway between each pair, except in the panels next to the bearings, where there are no tie bars. These crossbeams project below the soffit plates to support them. In the smaller span, there is only one crossbeam, or rather cross plate, as it does not support the soffit plates. It is located at mid span, with a tie bar closely adjacent to it and alternating from side to side of it.
- 3.9 The crossbeams are flat plates with discontinuous flanges at each end, at the top and bottom corners. They are shaped to fit the profile of the sides of the girders. In the main span, but not in the smaller span, there are widened strips, or 'bosses', of matching width, cast on the sides of the girders to receive the crossbeam flanges. The mating surfaces were bedded to each other with iron cement (traditionally, an expansive paste made of iron filings and ammonium chloride), and the whole tightened with an iron wedge. In the example opened up in the main span, there was a wedge in one top corner, while some other crossbeams, visible from beneath, have a wedge in a bottom corner. (In the smaller span, only one end of the crossbeam was opened up, so the presence of a wedge is not verified but it is presumed.) The re-entrant wedge shape of the girder sides also helps to locate the crossbeams. The embossing of the bearing surfaces may have allowed dressing to shape, if necessary, while it will have provided clearance for driving the wedges with a hammer.
- 3.10 The crossbeam that was opened in the main span was embossed with a letter 'H', which may denote the eighth bay from the north-west face. It was slightly asymmetrical. The bulbs of the heavy girders of the main span have bulged slightly wider than the 7 inches (178mm) shown in Brunel's notebook and they are not centred at all accurately over the webs and flanges below, so that the slope of the tapered face of the bulb varies. This evident difficulty in producing a regular girder casting probably necessitated the tailoring of the crossbeams to the individual bays, following measurement in a trial assembly.
- 3.11 The successive crossbeams also have to vary (more predictably) across the span, to fit the varying depth of the girder, with its differing slopes top and bottom. They are placed roughly radially, as shown in Brunel's notebook. The web of the example opened up had a slope (measured 11°) intermediate between that of the bottom of the girder (measured 9°) and the top of the girder (measured $11\frac{1}{2}^\circ$), while its flanges matched the top and bottom slopes.

Soffit Plates

- 3.12 The main span has seven soffit plates in the length of the span, all arching in the direction of span from crossbeam to crossbeam (the Brunel notebook does not show all of these). They bear onto flanges cast on the bottom edges of the crossbeams, and they are bedded in iron cement. They are arched in the direction of span, from crossbeam to crossbeam. They are straight in the lateral direction, with a clear gap alongside each girder web. To allow their insertion between the girder bulbs, the plates in each panel are made in two halves, with a lapped joint longitudinally, parallel to the direction of span. There is a downstanding stiffening rib alongside this joint on the lower of the two plates. The plates are a nominal $\frac{3}{4}$ inch (19mm) thick, with an upstanding stiffening rim all round. There are two lifting holes in each piece, in the south-eastern half of the bridge, and two more holes are added in the north-western half, giving greater manoeuvrability.
- 3.13 At their corners, these plates are notched, and their undersides are chamfered, to avoid the end flanges of the crossbeams and the tops of the lower flanges of the girders. The presence of iron cement and the proximity of the girder flanges prevented the precise recording of the geometry at these points. In the panel that was inspected from above, there appeared to be a nominal gap all round the rim, and the plates were reliant for location on the iron cement filling and two wrought-iron wedges driven in from above, one midway along the central joint and one at a lower corner against the web stiffener over the girder bearing.
- 3.14 The five soffit plates in the smaller span are supported in the other direction, on the lower flanges of the main girders without the use of crossbeams. They are therefore arched transversely, like jack-arches, while they also have a slight curvature longitudinally, following that of the girder, i.e. their curvature is two-way. There is a transverse joint every 3 feet 3 inches (0.99m), with a downstanding stiffening rib on one side, and the top surface is flush. The lap at this joint is only nominal, filled with iron cement or natural rust. These plates are again $\frac{3}{4}$ inch (19mm) thick, with two lifting holes. Where they meet the girder flange, the edge turns up slightly to avoid the fillet at the bottom of the girder web. There appears to be filling of iron cement beneath, particularly at the corners of the plates. The example that was opened up from above had about 3mm of lateral separation between the plate edge and the face of the web, filled with iron cement or rust that was soft to the chisel. Inspection of the underside showed variations in the lateral positioning of the plates, and the lateral separation is likely to be wider, but not smaller, in some other bays.

Edge Bays

- 3.15 The cross plate in the smaller span was on top of the soffit plates and bore down on their edge above the flange of the girder. This indicates a reversal of the assembly sequence used in the main span.
- 3.16 The edge bays, visible from below, were not investigated from above. Jack arches are used instead of the iron soffit plates. The jack arches rise 210mm above the beam soffits, so there is room for tie bars to be concealed within them. Such bars would be seen as necessary structurally. But the use of crossbeams as spacers is unlikely here, because of a lack of need and lack of space, the jack arches taking their place. The jack arches are laid in Roman cement mortar, which gives great strength, and it is possible they are only half a brick thick so as to leave room for gas and water mains above. There are the remains of a two-coat rendering of Roman cement on the soffit, which would disguise the brickwork and make it look more like the ironwork. So the use of

brickwork at the edges was probably not for aesthetic reasons.

Concrete Filling

- 3.17 The edge girders have a wider flange on their outer face, thicker but untapered, as a shelf to support the fascia brickwork. The lower edge is bevelled. The upper part of these girders may have a more conventional, rectangular flange, better suited to supporting the brickwork.
- 3.18 The mass concrete filling of the bridge deck is of lime concrete, with plentiful lime and fine aggregate, and it is very well compacted. The coarse aggregate is of well-rounded, flint gravel, up to 50mm across (with occasional sea shells). There are plentiful soft lumps of slaked lime (or unburnt chalk) up to 30mm across. The generally good condition of the ironwork suggests that this material has been present from the beginning.
- 3.19 Above this mass concrete, in the trial pit over the main span, there was found a layer of lean mix concrete, very sandy, beneath a uniform 100mm layer of cement concrete and 130mm of hot rolled aggregate. The lean mix increased in depth towards the haunch, suggesting a saving of materials. A disused 3-inch gas pipe, probably for street lighting, was trenched longitudinally in similar 'lean mix'. In the second trial pit, over the smaller span, there was a further layer of more finely-graded lime concrete, above an intermittent rubble where areas of lime concrete appeared to have been broken out and re-compacted. This occurred particularly at the centre of the span where there had been a previous exploratory pit between the girders.

Brickwork

- 3.20 The bricks used in the bridge piers and fascias are handmade, multicoloured London stock bricks, which would be fired in clamps and then selected for strength. Where the colouration is a dappled yellow, this is largely confined to the surface, the fabric internally being dark pink tending to purple, indicating hard burning. The brickwork is laid to Flemish bond, rather than the English bond that was favoured for less aesthetic structures. The mortar is of white lime, with some sharp sand aggregate, of varying hardness. The navigation pier has been partly refaced in engineering bricks and re-pointed with Portland cement mortar, particularly on the side facing the main span. Roman cement mortar was used in the jack arches and for the bedding of the seating plates as noted above.

4. GENERAL CONDITION OF IRONWORK

- 4.1 In the Trial Pit 1 over the main span, after removal of the concrete, the cast ironwork was found generally in very good condition, with no rusting over much of the main girders where they had been in contact with the concrete. In other places, brown to black rust had permeated the concrete, causing pieces of aggregate to adhere to the ironwork – this included the rims of the soffit plates next to the girders, where it could readily be chiselled off to reveal open joints below. The upper surface of the soffit plates was partly rust free (with a possible coating of lime wash). But in the less sloping areas there was a 5mm or thicker build-up of rust which could be removed by lightly chiselling by hand to reveal the crisp form of the joints. The crevices were however filled with iron cement or mortar from the concrete. This was found soft enough to be chiselled by hand, where space permitted, but this was time consuming.

- 4.2 The 1¼ inch (45mm) wrought-iron tie bars in the first trial pit had a significant build-up of about 5 to 10mm of rust, including embedded aggregate, but when this was removed, the holes through the webs were seen to be crisp and clean. The large nuts were easily cleaned up with a chisel and the ends of the bars within the nuts could then be seen sharply as if they might readily unscrew.
- 4.3 The underside of the main span reflects the same good condition, with an unblemished coating of bituminous paint. This span may have been given a thorough cleaning and repainting in relatively recent years. There are thin dribbles of lime issuing from holes but little total build-up. Iron cement, rather than rust, appears to have smoothed over some of the features of the joints.
- 4.4 The soffits of the main-span girders show an irregular, pitted and scalloped surface which is not seen on other ironwork. There are chips and other flaws in at least one flange edge. Both effects may be associated with the casting process, since the soffit plates are not affected. Various triangular notches in the flange edges may have been caused by impact damage, yet they are distant from the edge girders and at points where the headroom is highest. The bottom of one crossbeam appears to have been replaced, however, and another has split.
- 4.5 In some soffit plates in the main span in the north-western half of the bridge, there is a longitudinal crack adjacent to the downstand rib, which has propagated from one end of the plate towards the centre, or beyond. This should not impair the arching action of the plate but it may reflect some incompatibility of stiffness or support between different parts of the plate, or a hidden thinning of the plate at the longitudinal lap joint. A few of these soffit plates also have exposed areas of blow holes.
- 4.6 The shorter span appears from the underside to be in less good condition, particularly on the north-east side, with about 5 millimetre build-up of brown rust and lime scale on some edges of the girder flanges. The configuration of the soffit plates here channels any water within the deck sideways towards the girders. The corrosion has not caused significant loss of section. Considerable areas are also encrusted with lime that has percolated out of the bridge deck.
- 4.7 On the upper side, in Trial Pit 2, the corrosion was evidenced by a 10mm or so build-up of black rust over much of the surface of the soffit plates, concealing the joints and largely blocking the lifting holes. The rust was able to be removed with careful chiselling. At the bottom corners, next to the springing line, a coating of Roman cement beneath a layer of mortar had protected the plate from rust but itself needed effort for its removal. The joints, about 3mm wide, were filled with rust or iron cement.
- 4.8 A back-filled pit at the crown of the arch around the crossbeam and tie bar in Trial Pit 2 had increased the corrosion there, with rust build-up around the crossbeam. Particularly, a layer of black rust completely filled the 20mm gap between the underside of the crossbeam and the top of the soffit plate.

5. **CONSIDERATIONS AFFECTING DISMANTLING**

- 5.1 If the structure is to be dismantled, there will be costs of labour involved in carefully breaking out the concrete, cleaning the metal to reveal the joints and cleaning out those joints where a filling of rust, iron cement or mortar would prevent pieces from sliding

apart. The excavations demonstrated that it is possible to remove the superficial rust on the soffit plates, without breaking them, by careful chiselling with a light pneumatic pick held loosely, but this is time consuming. There is the separate risk of breaking the cast-iron plates, particularly by leverage, if the pieces do not come apart readily.

- 5.2 The careful breaking out of the asphalt and concrete to form each trial pit, 3 metres long by 1.5 metres wide, took about 1½ days per pit, using pneumatic picks. Cleaning the superficial rust over the joints would take another half day. The cleaning out of joints, where accessible, has not been quantified.
- 5.3 In the main span, the lifting out of the soffit plates would be assisted slightly by their convex longitudinal shape, putting the transverse joints into tension, and by the open joints alongside the girder webs. The tensile strength of the filling material in the transverse joints might need to be weakened by drilling or grinding out. The filled-in joints at the corners would bind in shear, however, unless cleared out with much trouble. 'Stiction' of the iron cement, although less than the tensile strength of iron, would introduce further unpredictability. Movements would have to be carefully controlled to avoid bending of the plates leading to breakage. Removal of the securing wedges would have to proceed first, but may be difficult where they are bound with iron cement or rust. An alternative approach of freeing up the girders in advance of the removal of the plates, by lifting them slightly in order to slide them sideways after slackening the tie bars, might be hampered by tight adherence of the iron cement to the bearings.
- 5.4 Despite the heavier rusting, the simpler geometry of the smaller span could make it easier to remove the soffit plates there, provided that rust in the narrow longitudinal joints against the girder webs can be ground out or pulled apart. The pinning down of the middle plate by the 'crossbeam' at the crown requires the latter to be removed first. Freeing its tightening wedge is unlikely to be sufficient because of the iron cement and rust that is likely to be binding the other corners.

6. OUTLINE OF HISTORICAL SIGNIFICANCE OF THE IRONWORK

- 6.1 The period of the early main line railways, circa 1825 to 1850, saw great advances in the design of iron girders (as distinct from arches), first in cast iron, and then in wrought iron, in order to achieve longer and shallower spans for the special circumstances of railway alignments. But increasing loads, and the uncertainties associated with brittle cast iron, have led subsequently to the replacement of virtually all the girders that were provided for under-line use in this period and most of those that were used to carry roads. The surviving girders and other associated ironwork of the Paddington bridge, therefore, have considerable archaeological value, as illustrations of aspects of the current state of the art in 1838, even before one considers the special features of a design by a remarkable engineer.
- 6.2 In 1838, wrought-iron girders had not yet been developed, and the choice for shallow spans was between non-durable timber and cast iron. Although Brunel built many structures in timber, a more permanent solution was appropriate at this prominent urban site next to the railway terminus, forcing him to use a material he mistrusted, cast iron. This is one of very few bridges by him in cast iron and quite probably the first that he built. There were only two others on the Great Western Railway main line, an underline girder bridge of heavy skew across the Uxbridge Road at Hanwell, which did, indeed, fail and has been replaced, and a footbridge of conventional arched design in Sydney Gardens at Bath. Much later, he was responsible for the cast-iron canal aqueduct over

the line to Brentford Dock near Hanwell, with a shallow cast-iron-girdered road bridge over it. This also has a challenging layout but, built in 1857 two years before his death, it may have had less of his personal involvement.

- 6.3 A significant aspect of the Paddington bridge is the length of span employed. In 1838, no one had built girders that would span the full 18 metre (60ft) width of the canal and towpath, yet be shallow enough to fit beneath the roadway, not being designed as an arch. Beams in a single piece would have been too heavy to handle and difficult to cast reliably. To cross the Regent's Canal at Camden Town with a similar tight headroom, Robert Stephenson, with Charles Fox, had devised composite cast- and wrought-iron bowstring trusses that stood above track level as "through" girders. The Paddington site would have needed three such trusses, one of them down the middle of the road, with cross girders spanning between them. That would have been unsightly for a public road, and costly. However, Brunel was able to satisfy the canal company that he was making the principal opening as large as he possibly could, "consistent with safety"⁽¹⁰⁾. The 10.7 metres (35ft) remains an impressive span for simple cast-iron beams. It may be noted that it was Stephenson's subsequent pursuit of shallow girders, reinforcing cast iron with wrought iron, that led to the dramatic failure of the Dee railway bridge at Chester in 1847 and helped steer the course of development of girders away from cast iron entirely⁽¹¹⁾.
- 6.4 Decreasing the depth of the girders from the middle to the ends, in a smooth, "hogbacked" curve, had for long been a standard practice where a level top was not required, reflecting approximately the variation of the bending moments along the beam. Considerably more unusual, in such girders, is the pronounced concave curve given here to the soffit. This "banana" or sickle-shaped girder profile had very recently been used by Robert Stephenson, on the other pre-eminent railway line of the decade, the London & Birmingham Railway, for the Hampstead Road and other bridges south of Camden Town. There again there were architectural reasons, on the approach to the Euston terminus, for using an arched soffit. They may have been designed by Stephenson's assistant Charles Fox, soon to be renowned for his iron roofs and the structural ironwork of the Crystal Palace. These bridges have been replaced, making the Paddington girders possibly the earliest remaining of the type. Their form was invariably concealed from view.
- 6.5 A curious feature of the Paddington girders is the great size of the top bulb. Cast-iron girders had been in fairly widespread use in major buildings from the 1820s, at least in London. An increasingly common form from the mid-1820s comprised a substantial bottom flange to take the bending tension and a vertical web, terminating in a small top flange or bulb to resist the bending compression and any tendency to buckle sideways. While a broad bottom flange had a useful function as a seating for jack arches or masonry walls, these proportions were also in accordance with the lesser relative strength of cast iron in tension compared with compression. This indicates that the larger part of the cross sectional area should be placed in the bottom flange to achieve the most economical form, of least weight for a given strength, the "balanced section". There was not a formal understanding of this point in the 1820s, and some practitioners continued to use inverted-tee sections without any top bulb (as first developed for the jack-arch floors of textile mills in the 1790s), while Thomas Tredgold, in his textbook of 1822 and 1824, saw no difference between the tensile and compressive strengths of cast iron, leading to flanges of equal area being adopted in many cases⁽¹²⁾. There were also examples of a tee section, with the top flange very much larger than the bottom bulb, if any, but they were usually light members where strength against lateral loading or space to rest floor slabs or rafters was the primary consideration rather than reducing the weight of iron in the beam.

- 6.6 From experimental tests in the late 1820s, Eaton Hodgkinson deduced that the optimum ratio for the areas of the bottom and top flanges was six to one. His research was presented in Manchester in 1830-1, but not published nationally until 1846⁽¹³⁾. Robert Stephenson, having witnessed some of these tests, used flange proportions based on Hodgkinson for the first major iron-girder bridge, beneath the Liverpool and Manchester Railway at Water Street, Manchester, in 1830⁽¹⁴⁾. Surviving iron girders of 1831 on the former Innocent Railway, Edinburgh, have a 3 to 1 ratio of bottom to top flange⁽¹⁵⁾, and Stephenson's Hampstead Road bridge of 1836 had a ratio of 3.5 to 1⁽¹⁶⁾. Such proportions had become commonplace by the mid-19th century.

The main-span girders at Paddington, on the other hand, have the top bulb bigger than the bottom flange, by a factor of 1.4, larger even than the equal areas that Tredgold would have had, while the side span girders, where the bulbs are deeper than Brunel indicated in his notebook, are still more disparate. Perhaps not in touch with the latest knowledge, Brunel was taking a characteristically independent line, although his logic is not clear. It is interesting that ten years later, in evidence to the Royal Commission on the Application of Iron to Railway Structures, he claimed to design cast-iron girders entirely on Hodgkinson's principles.

- 6.7 The use of a rounded bulb rather than a rectangular top flange is also curious, since the latter form would allow the iron to be concentrated closer to the extremity of the section, giving greater bending resistance. Coincidentally, Brunel was later to use such a rounded form distinctively in the 1850s, when he designed the upper chords of wrought-iron girders, his trussed tubes at the Saltash bridge being the ultimate example. The logic of these, relating to the greater buckling resistance of thin plates when laterally curved, is totally unconnected with the behaviour of cast-iron beams, nor could it have been predicted in 1838. Nevertheless, the striking similarity of the double-curved geometry of the nose of his wrought-iron-girder swing bridge (c1849) at Cumberland Basin, Bristol, suggests a recollection of the Paddington bridge⁽¹⁷⁾.
- 6.8 Flat or ribbed plates, sometimes slightly dished, had been used for the soffits of iron road bridges for many years, and two-way-curved "buckle plates", hydraulically pressed from wrought iron, were later to take their place. An excellent example of proto-buckle plates in cast iron is at the Harrow Road canal bridge of 1866 in Westbourne Green, W9, a kilometre west of Paddington. However, those in the Paddington bridge, simulating jack arches, are more elaborate, as was often the manner of Brunel's work. (Stephenson had used brick-jack arches at Hampstead Road, but he was not working above a busy canal.) The bearing of the internal crossbeams against the re-entrant corners of the girder sides is another, yet more individualistic feature. One comes away with the conclusion that this bridge embodies a great deal of original thought on the part of its designer.

7. REFERENCES

1. S. Brindle, *Isambard Kingdom Brunel and the Bridge over the Grand Junction Canal, Bishop's Road Bridge, Paddington*, unpublished typescript, English Heritage, 2003.
2. M. Tutton, *Paddington Station 1833-1854*, Railway & Canal Historical Society, 1999.
3. PRO: RAIL 1149/4, IK Brunel letter book, letters of 18 and 25 May 1838 to Grand Junction Canal Company, quoted in Brindle, *op. cit.*
4. Tutton, *op. cit.*, p 17.
5. Network Rail, Swindon Records Centre, Document 16131.
6. *Ibid.*
7. e.g. Tutton, *op. cit.*, pp 30, 41, 43; Hyder Consulting Ltd, *Bishop's Bridge Detailed Assessment*, 1997.
8. As note 5.
9. PRO: RAIL 1149/9, pp 96-9.
10. As note 3.
11. RJM Sutherland, The Introduction of Structural Wrought Iron, *Transactions of the Newcomen Society*, **36** (1963-4), 67-75.
12. RJM Sutherland, "The Age of Cast Iron 1780-1850: Who Sized the Beams?", in R Thorne (ed), *The Iron Revolution, Architects, Engineers and Structural Innovation 1780-1880*, RIBA, 1990.
13. Eaton Hodgkinson, "Theoretical and experimental researches to ascertain the strength and best form of iron beams", *Memoirs of the Manchester Literary and Philosophical Society*, vol 5 (1831) pp 407-544 (read at Manchester 2 April 1830);

T Tredgold and E Hodgkinson, *Practical Essay on the Strength of Cast iron and Other Metals*, 4th edition, vol 2, London, J Weale, 1846.
14. RS Fitzgerald, *Liverpool Road Station, Manchester*, Manchester University Press, 1980, pp 23-28.
15. ICE Panel for Historical Engineering works, *PHEW Newsletter*, No 97, March 2003.
16. SC Breese, *The First Series of Railway Practice*, London, John Williams, 1838.
17. R Cragg (ed), *Civil Engineering Heritage, Wales and West Central England*, London, Thomas Telford, 2nd edition 1997, p 123.

8. MEASURED DRAWINGS

Drawing No:

1. Key Plan
2. Plans on Trial Pits Nos 1 and 2
3. Main Span, Girder Elevation and End Details
4. Main Span, Details of Crossbeam (Sheet 1)
5. Main Span, Details of Crossbeam and Tie Bars
6. Main Span, Soffit Plate Details (First Panel)
7. Main Span, Cross Section at Face of SW Pier
8. Side Span, Girder Elevation and End Details
9. Side Span, Details at Mid Span
10. Side Span, Details of Soffit Plates
11. Side Span, Cross Section at Mid-Canal Pier

(SW)

(NE)

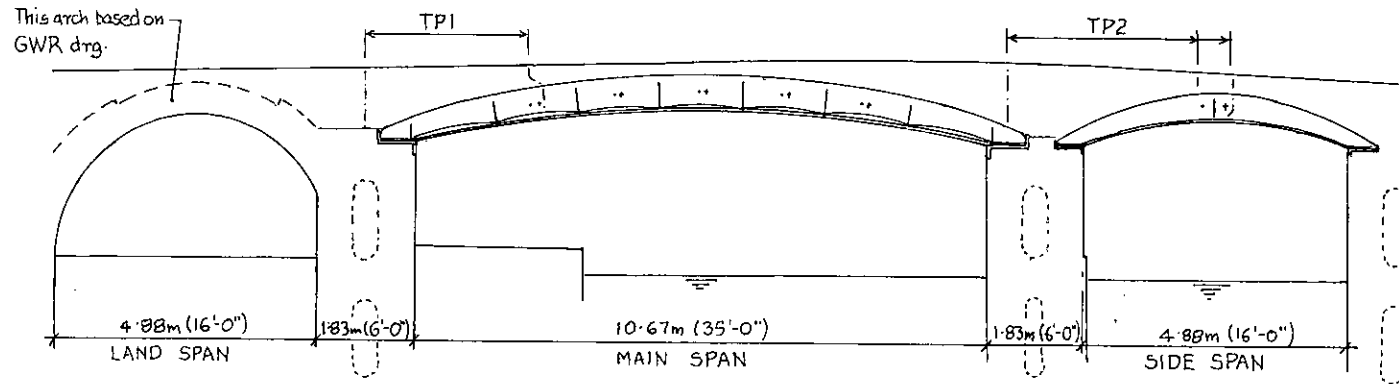

X - X (1:100)

Side Span:-

- 9 no. Main Girders Type C
- 2 no. Edge Girders Type D
- 1 no. Cross Plate } in 8 bays
- 5 no. Soffit Plates }
- 2 no. brick jack arches J

Main Span:

- 9 no. Main Girders Type A
- 2 no. Edge Girders Type B
- 6 no. Cross Beams } in 8 bays
- 7 no. Soffit Plates }
- 2 no. brick arches J

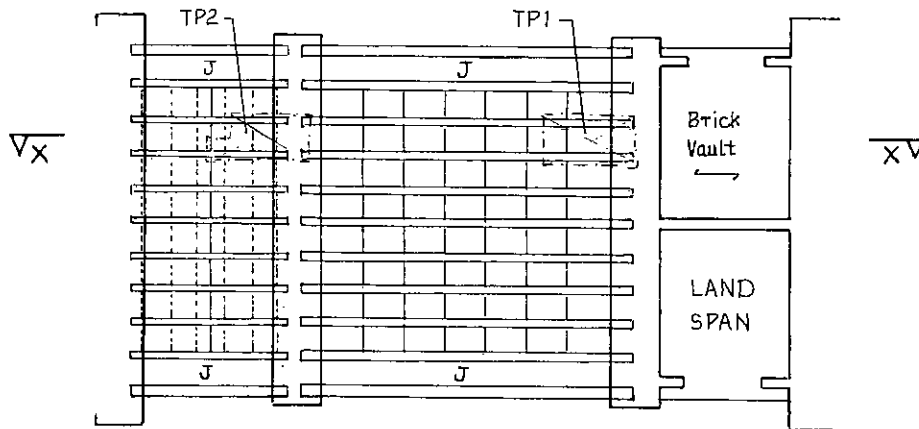

REFLECTED PLAN (1:200)

BISHOP'S BRIDGE ROAD CANAL BRIDGE
KEY PLAN

Survey by M.T. Tucker, August 2003
for
English Heritage

DRG. NO 1

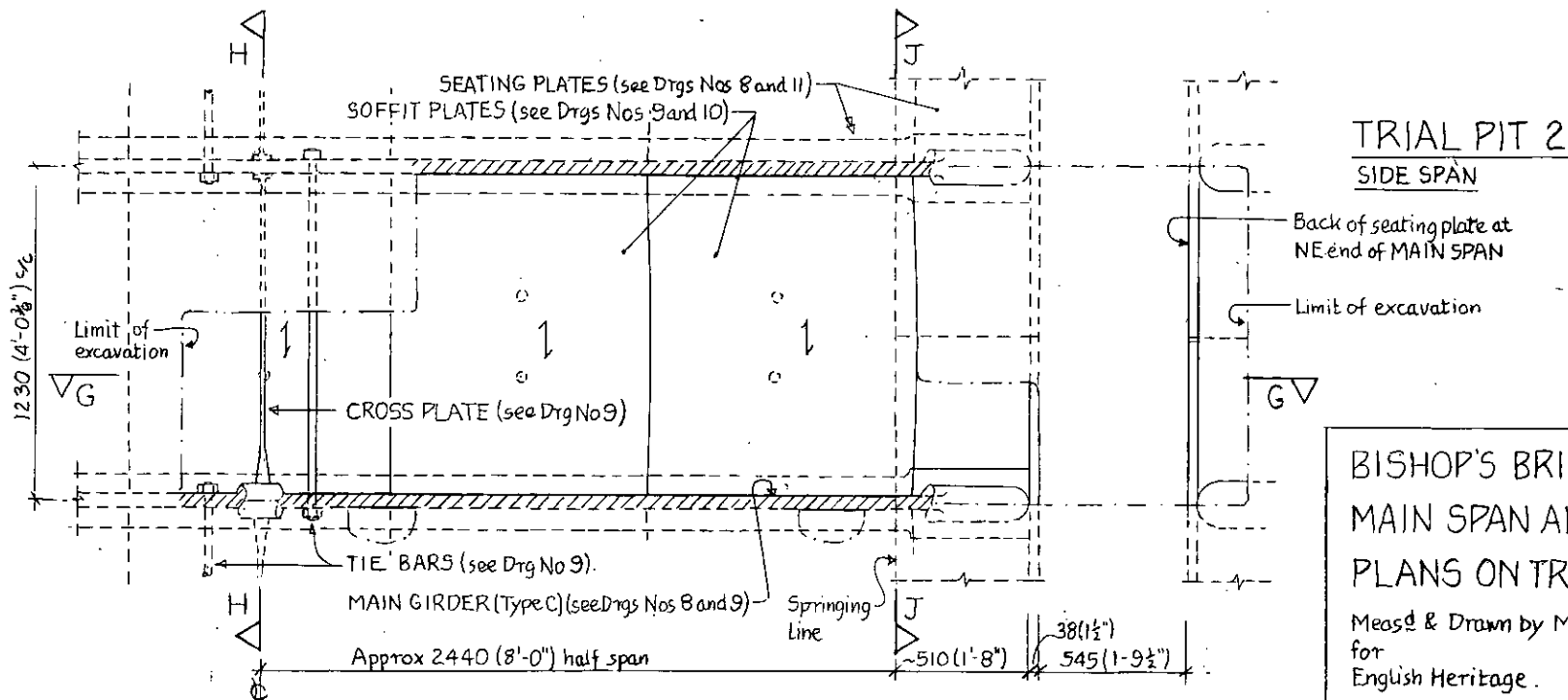
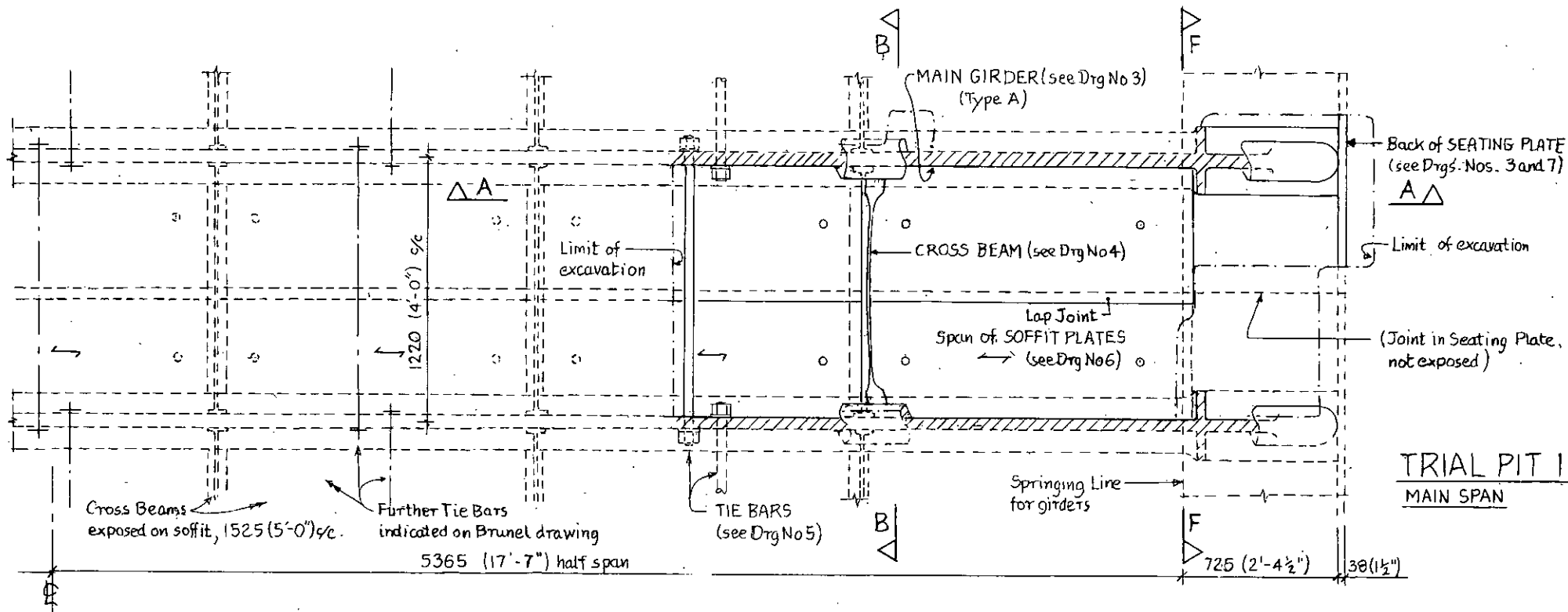

PLANS DRAWN GENERALLY AT LEVEL OF SOFFIT PLATES

BISHOP'S BRIDGE ROAD CANAL BRIDGE
 MAIN SPAN AND SIDE SPAN
 PLANS ON TRIAL PITS

Meas'd & Drawn by M.T. Tucker, August 2003
 for English Heritage.

1:20 at A3 DRG. No 2

< NE

SW >

Drng No 7
F

Road falls 50 in 3.0 m

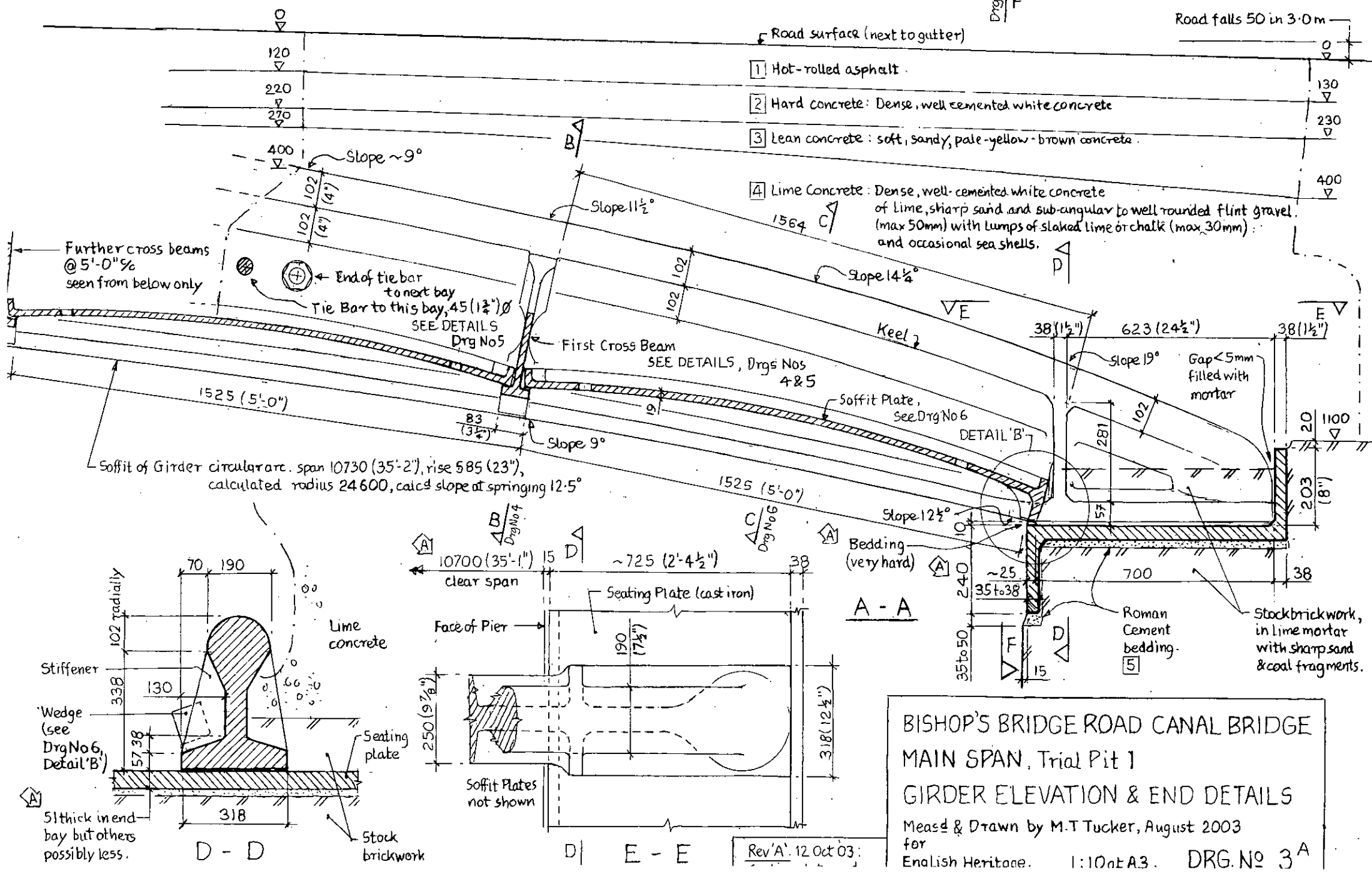

- 1 Hot-rolled asphalt
- 2 Hard concrete: Dense, well cemented white concrete
- 3 Lean concrete: soft, sandy, pale-yellow-brown concrete.
- 4 Lime concrete: Dense, well-cemented white concrete of Lime, sharp sand and sub-angular to well rounded flint gravel (max 50mm) with lumps of slaked lime or chalk (max 30mm) and occasional sea shells.

Further cross beams @ 5'-0" % seen from below only

End of tie bar to next bay
Tie Bar to this bay, 45 (1½") Ø
SEE DETAILS Drng No 5

First Cross Beam
SEE DETAILS, Drngs Nos 4 & 5

Soffit Plate, see Drng No 6
DETAIL 'B'

Soffit of Girder circular arc, span 10730 (35'-2"), rise 585 (23"), calculated radius 24600, calcd slope at springing 12.5°

Gap < 5mm filled with mortar

Bedding (very hard)

Roman Cement bedding.

Stock brickwork, in lime mortar with sharp sand & coal fragments.

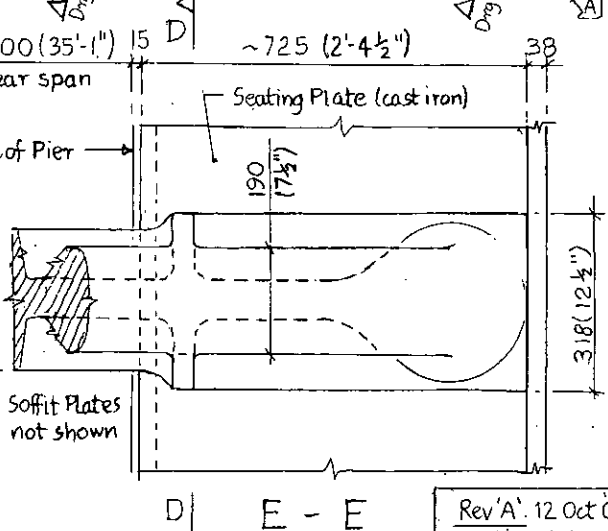
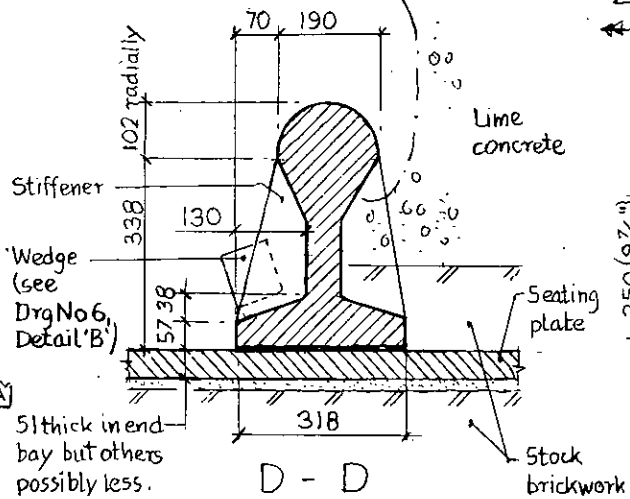

BISHOP'S BRIDGE ROAD CANAL BRIDGE
 MAIN SPAN, Trial Pit 1
 GIRDER ELEVATION & END DETAILS
 Meas'd & Drawn by M.T Tucker, August 2003
 for
 English Heritage. 1:10 on A3. DRG. No 3A

Rev 'A' 12 Oct 03

< NW

SE >

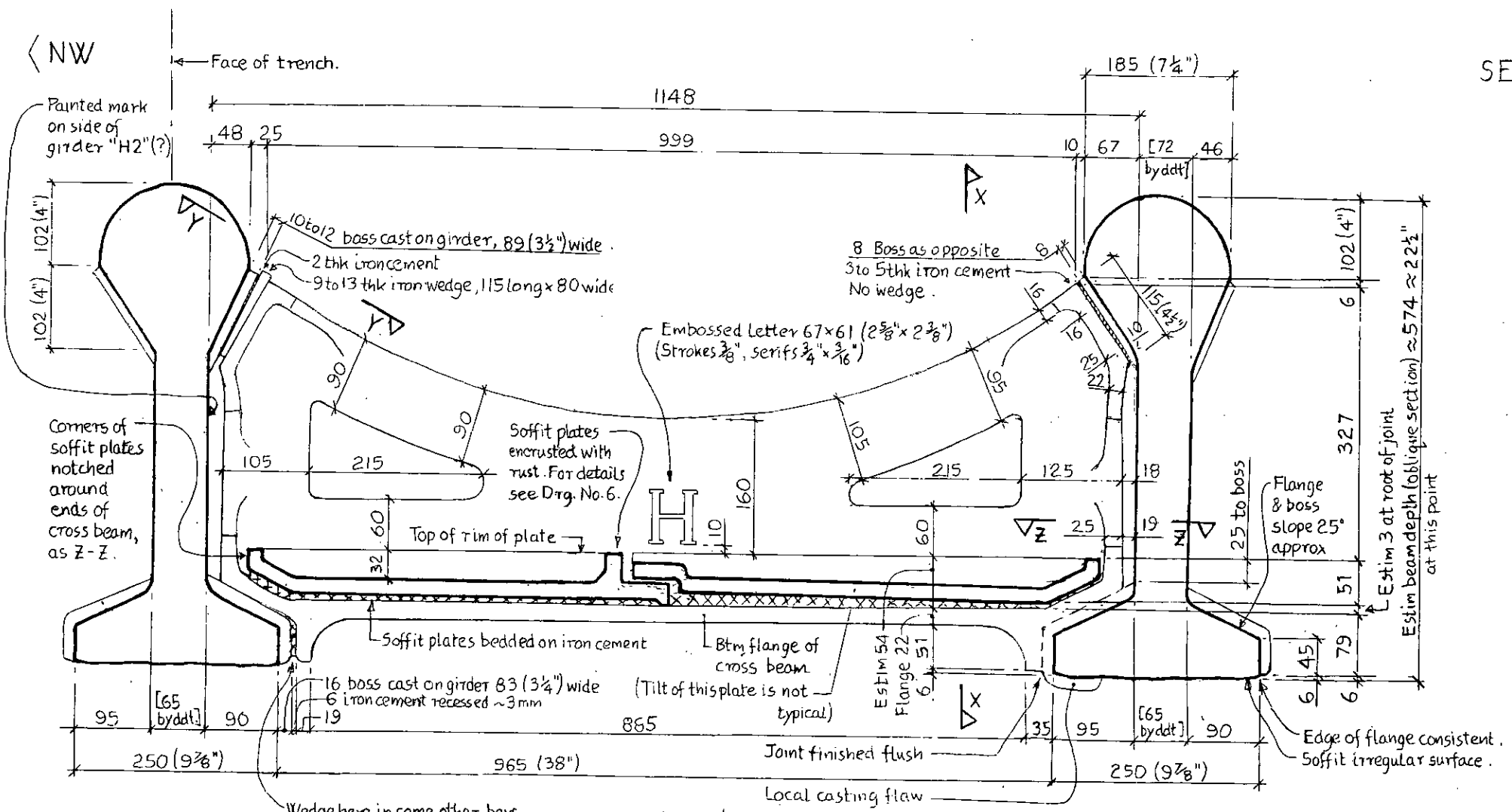

Wedge here in some other boys, where joint is wider.

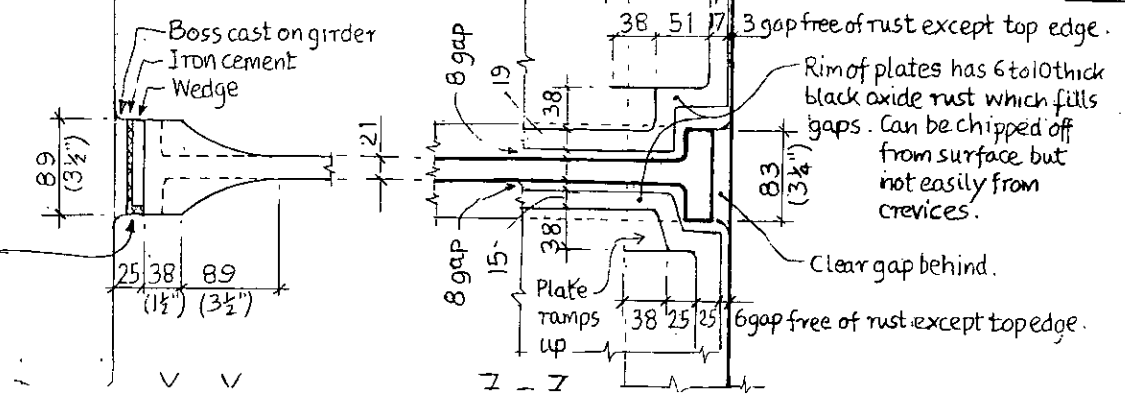

Rev A, Oct '03 : Soffit plates adjusted

BISHOP'S BRIDGE ROAD CANAL BRIDGE
 MAIN SPAN, Trial Pit 1
 DETAILS of CROSS BEAM (Sht 1)
 Meas'd & Drawn by MTTucker, August 2003
 for
 Finnish Heritage 1:5 at A2 DRG NO 1 A

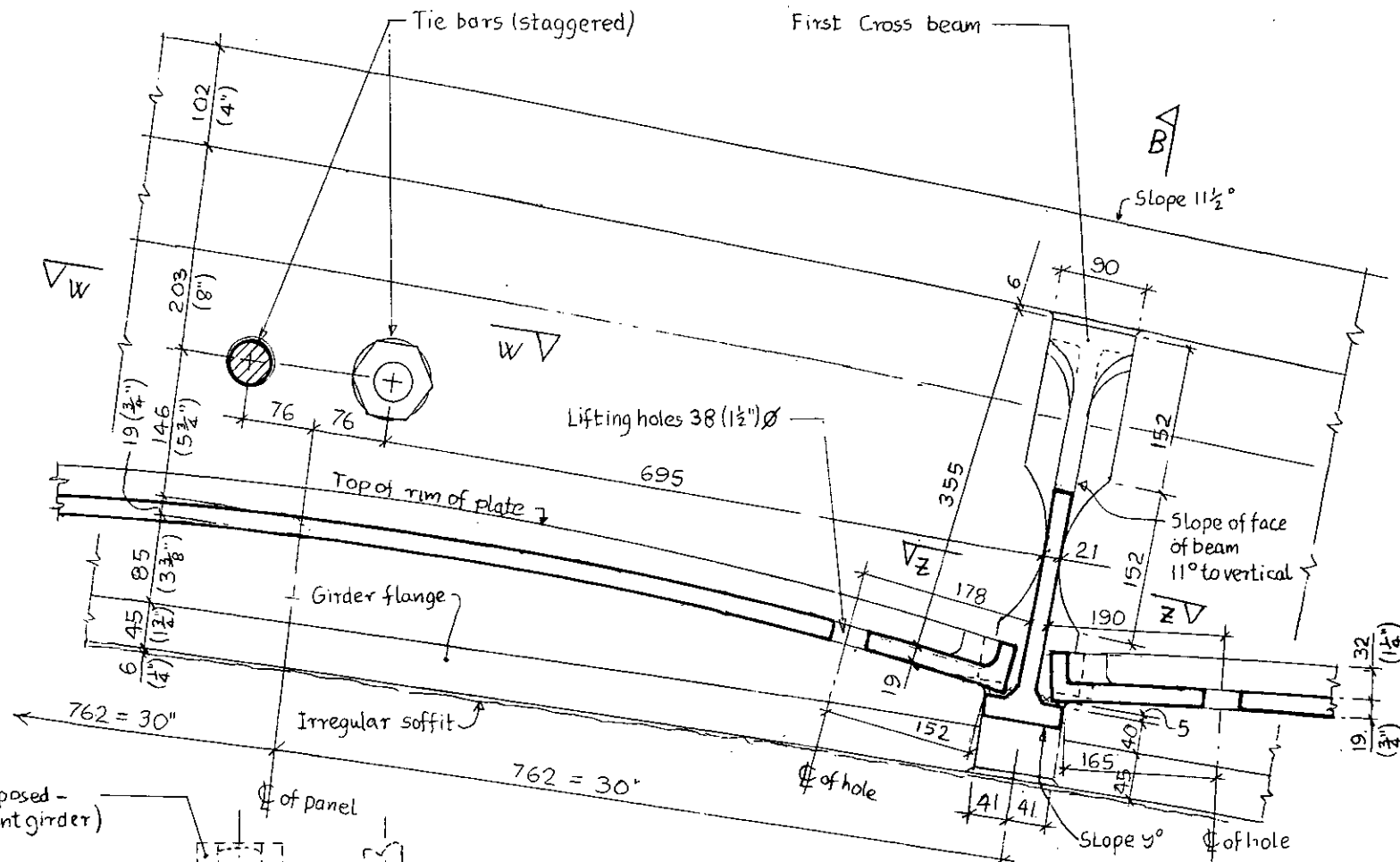

(This side not exposed - based on adjacent girder)

Hole 51 (2") ϕ , clear of rust when external rust removed.

Girder web

Wrought iron tie bars 45 (1 3/4") ϕ between single pairs of beams, staggered either side of centreline of panel.

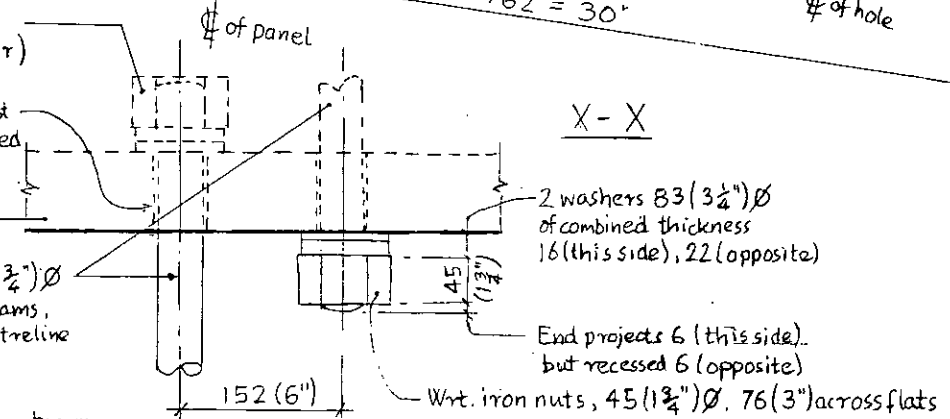

Wrt. ironwork encrusted with rust > 5mm thick, plus embedded aggregate. Cleans up readily with chisel.

W - W

BISHOP'S BRIDGE ROAD CANAL BRIDGE
 MAIN SPAN, Trial Pit 1
 DETAILS, CROSS BEAM and TIE BARS
 Meas'd & Drawn by M.T. Tucker, August 2003
 for English Heritage 1:5 at A3 DRG NO 5

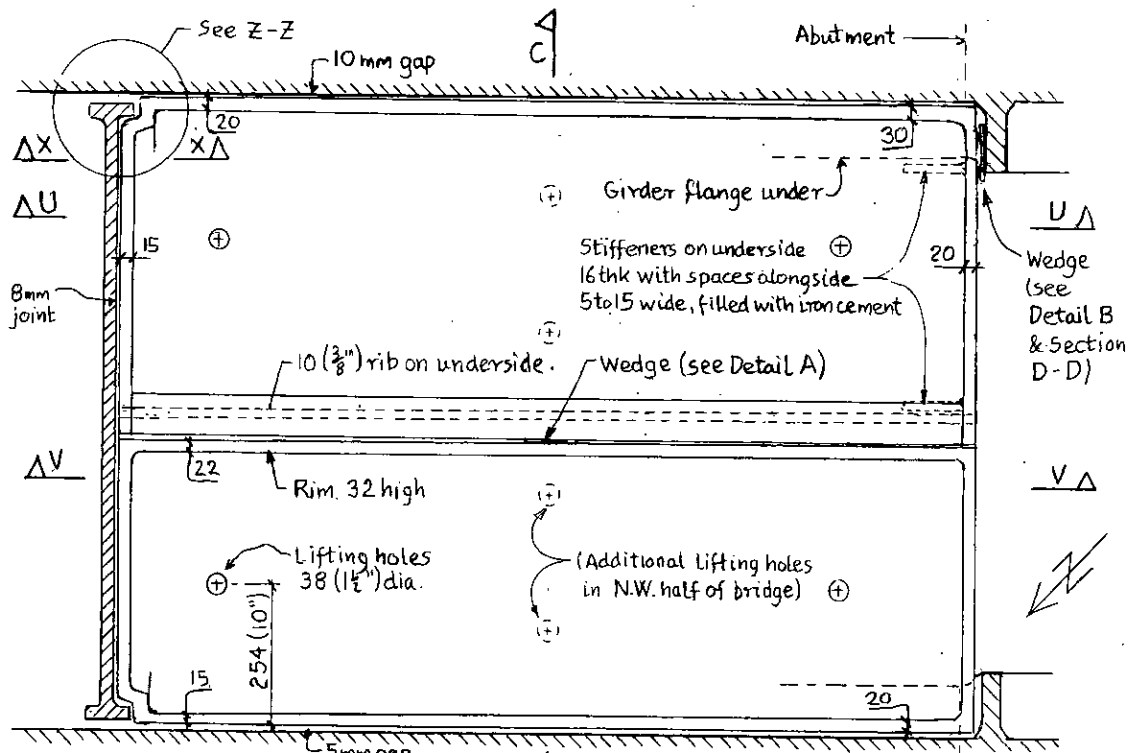

DEVELOPED VIEW ON TOP OF SOFFIT PLATES (1:10)

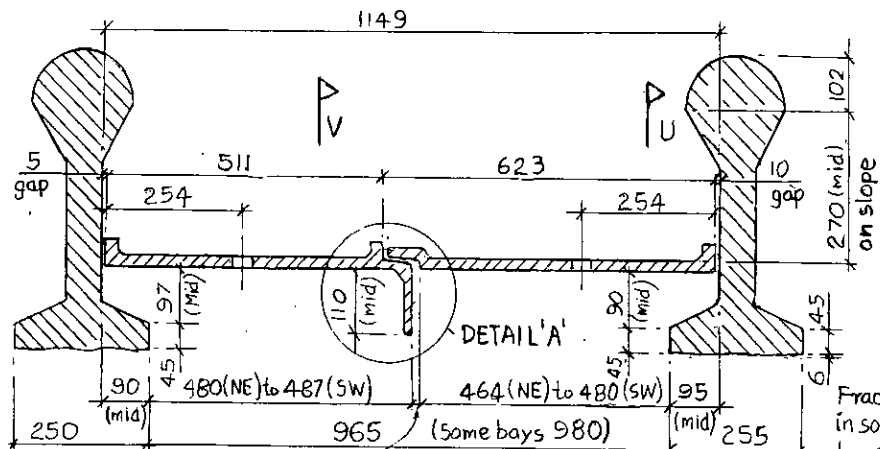

C - C (1:10)
"mid" = at mid-length of plate

Note: Dimensions recorded for the SW panel of Trial Pit 1. Other bays may vary slightly.

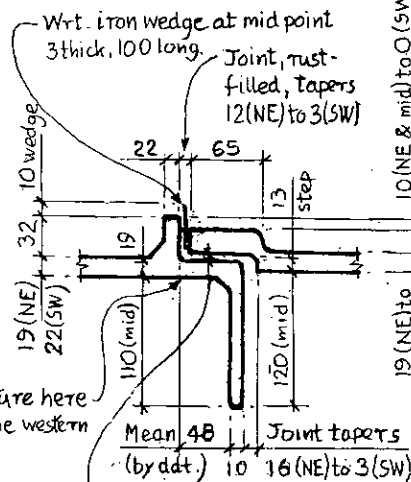

DETAIL 'A' (1:5)

Fracture here in some western bays.

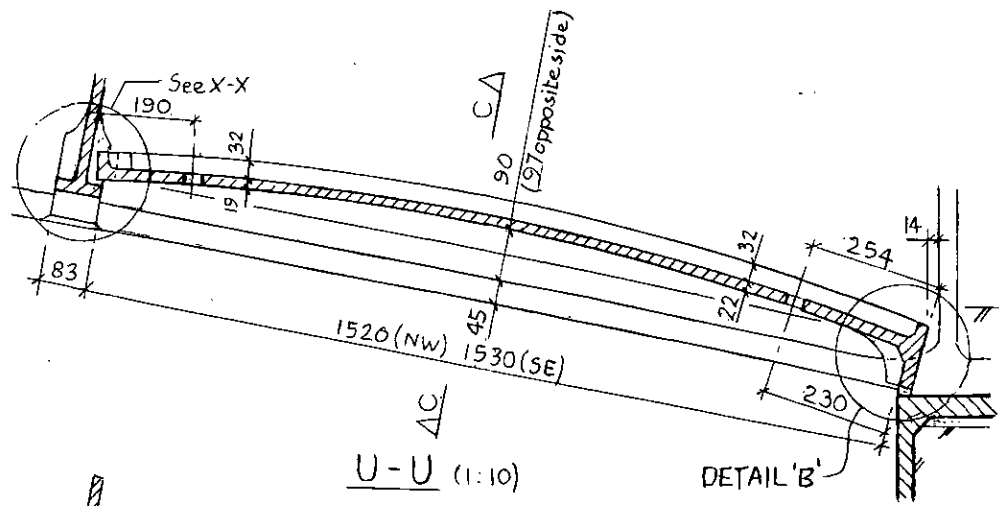

U - U (1:10)

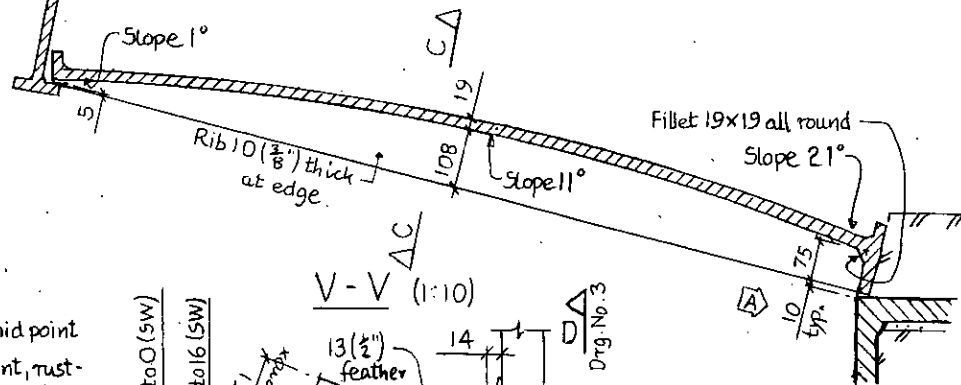

V - V (1:10)

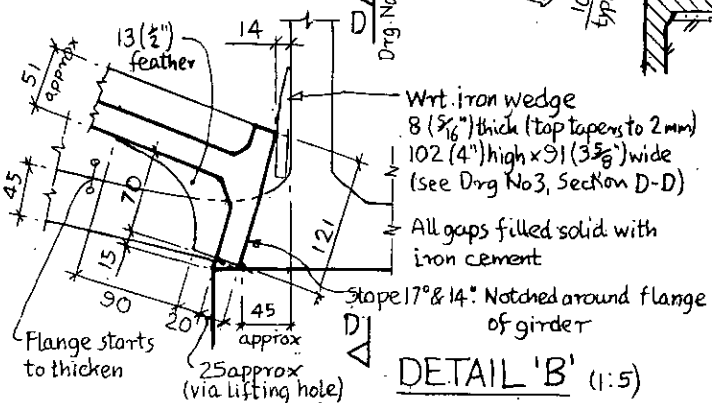

DETAIL 'B' (1:5)

BISHOP'S BRIDGE ROAD CANAL BRIDGE
MAIN SPAN, Trial Pit 1
SOFFIT PLATE DETAILS (First Panel)

Meas'd & Drawn by M.T. Tucker, August 2003
for

English Heritage 1:10/1:5 at A3. DRG. No 6A

Det. 'A' 12 Oct 2003. Detail amendments.

SE

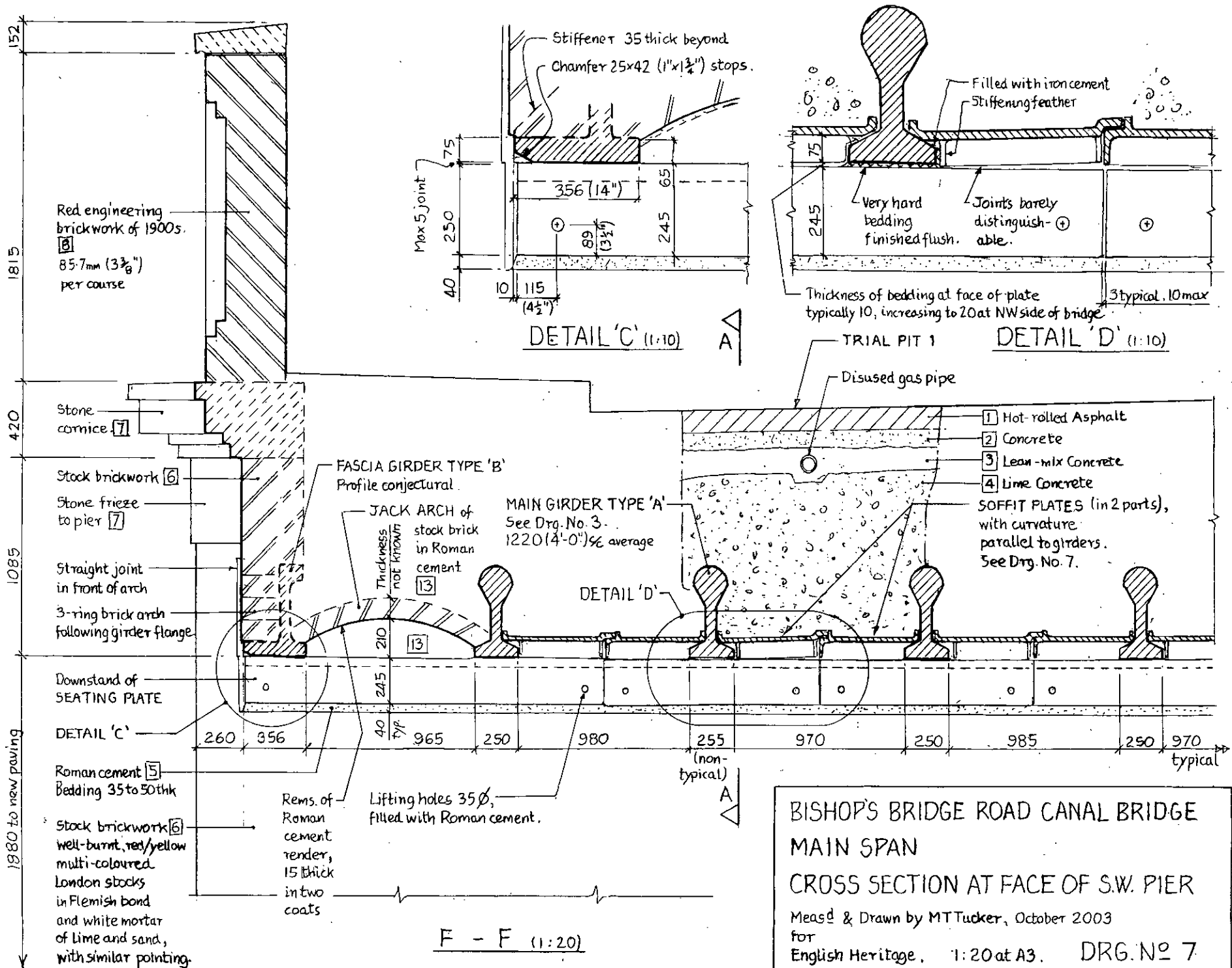

BISHOP'S BRIDGE ROAD CANAL BRIDGE
 MAIN SPAN
 CROSS SECTION AT FACE OF S.W. PIER
 Meas'd & Drawn by MTTucker, October 2003
 for
 English Heritage. 1:20 at A3. DRG. NO 7

SW

NE

(See R-R on Drg No 9)
Tie bars 38 (1 1/2") dia alternating on either side of central cross plate:

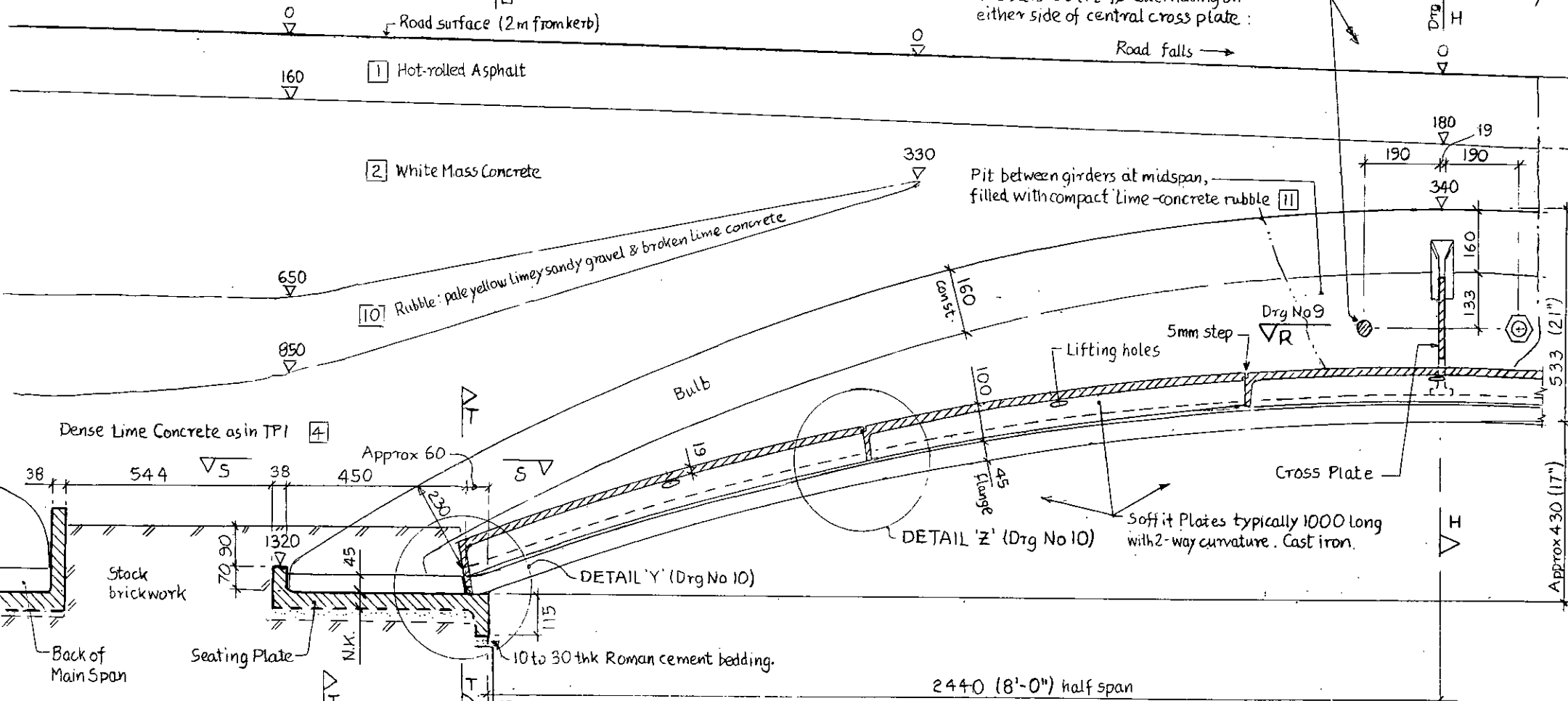

G-G : GIRDER HALF-ELEVATION (1:10)

Rev A: Oct '03: Detail amendments.

BISHOP'S BRIDGE ROAD CANAL BRIDGE
 SIDE SPAN, Trial Pit 2
 GIRDER ELEVATION & END DETAILS
 Meas'd & Drawn by M.T. Tucker, August 2003.
 for
 English Heritage. 1:10 at A3 DRG. NO 8A

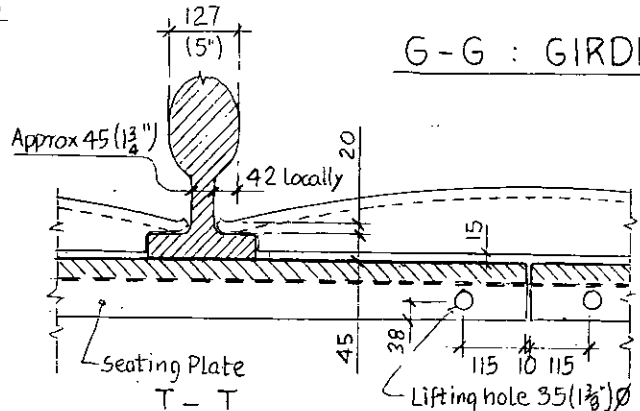
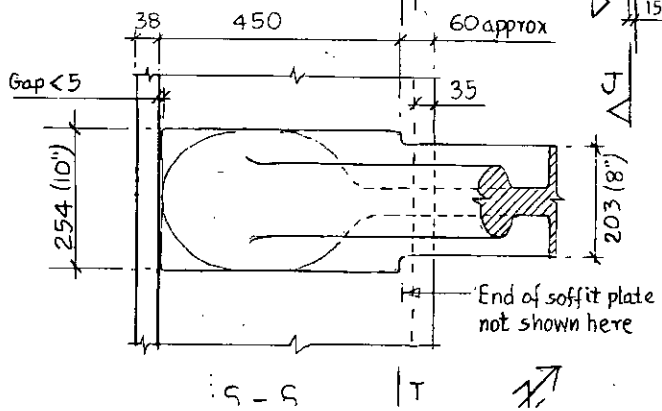

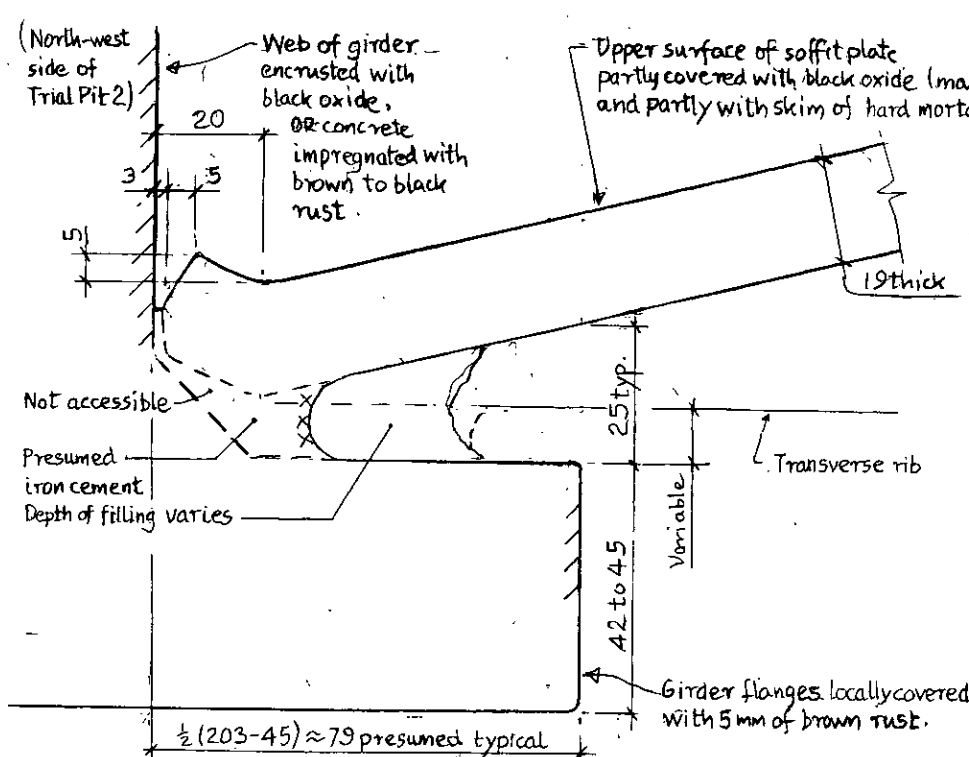

DETAIL 'X'
 JUNCTION OF SOFFIT PLATE & GIRDER (FULL SIZE)

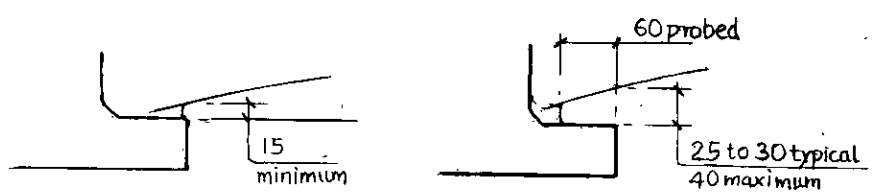

VARIATIONS ON SOFFIT AT DETAIL 'X' (1:5)

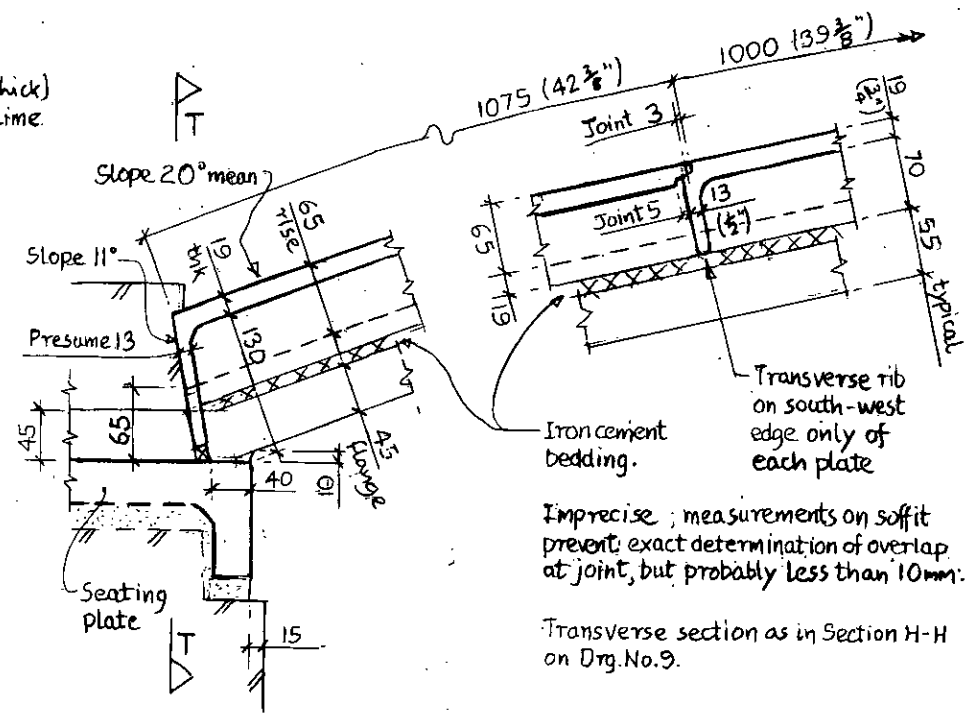

DETAIL 'Y' (1:5)

DETAIL 'Z' (1:5)

Imprecise; measurements on soffit prevent exact determination of overlap at joint, but probably less than 10mm.
 Transverse section as in Section H-H on Drg. No. 9.

Rev A: 28 Oct 2003: Detail 'X' redrawn and amplified.

BISHOP'S BRIDGE ROAD CANAL BRIDGE
 SIDE SPAN, Trial Pit 2
 DETAILS OF SOFFIT PLATES
 Meas'd & Drawn by M.T. Tucker, August 2003
 for
 English Heritage, 1:5 & 1:1 at A3 DRG. NO 10^A

<SE

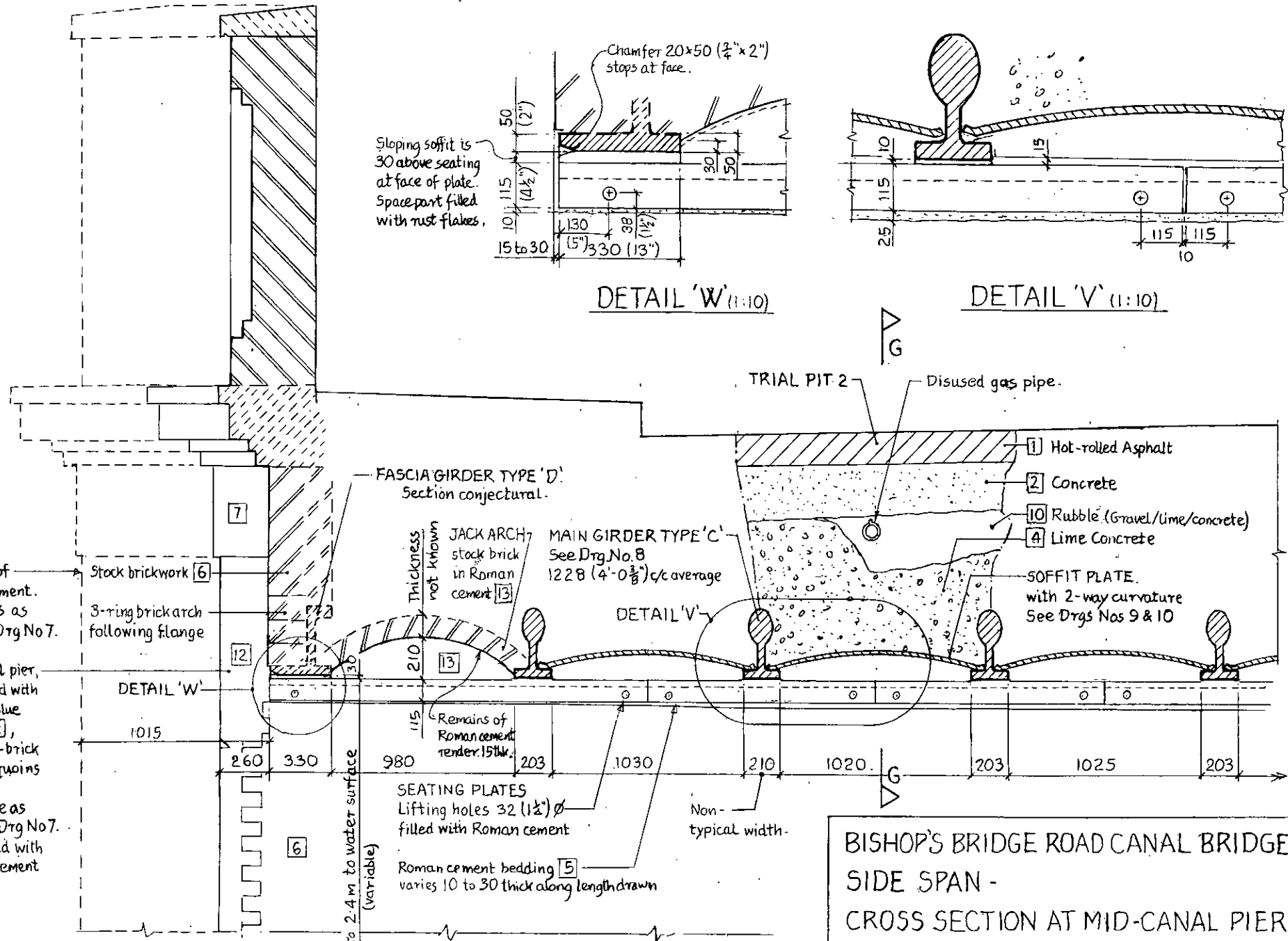

J - J (1:20)

BISHOP'S BRIDGE ROAD CANAL BRIDGE
 SIDE SPAN -
 CROSS SECTION AT MID-CANAL PIER
 Measd & Drawn by MTTucker, October 2003
 for
 English Heritage. 1:20at A3. DRG. No 11.

9. PHOTOGRAPHS

Figure No:	MTT Negative No
Cover: Main span from south	1287/15 ^A
1a General view from south east	1287/14 ^A
1b Land span, from east	1286/23 ^A
2a Mid-canal pier, south-east end from south	1286/19 ^A
2b Mid-canal pier, north-west end from west	1287/5 ^A
3a Main span, underside at north-west side from SW	1287/10 ^A
3b Main span, detail of soffit in NW part	1287/3 ^A
4a Main span, soffit plates side view from SE	1287/8 ^A
4b Main span, detail of soffit plates in NW part	1287/1 ^A
5a Main span, soffit and seating beneath Trial Pit 1, from N	1286/27 ^A
5b Main span, soffit and seating beneath Trial Pit 1, from NE	1286/24 ^A
6a Main span, soffit plates adjoining south-west seating, from E	1286/28 ^A
6b Main span, close view of seating plates, from NE	1286/30 ^A
7a Main span, main girder with defects in flange, from WSW	1286/36 ^A
7b Main span, bottom of crossbeam replaced, from WSW	1286/32 ^A
8a Main span, Trial Pit 1, general view from north east	1286/4 ^A
8b Main span, Trial Pit 1, general view from WSW	1286/3 ^A
9a Main span, Trial Pit 1, end of main girder, from NW	1286/0 ^A
9b Main span, Trial Pit 1, stiffener and wedge, from W	1286/2 ^A
10a Main span, Trial Pit 1, crossbeam and tie bar beyond, from SW	1285/26
10b Main span, Trial Pit 1, wedge in joint of plates, from W	1285/36
11a Main span, Trial Pit 1, crossbeam NW end, from S	1285/32
11b Main span, Trial Pit 1, crossbeam SE end, from W	1285/35
12a Main span, Trial Pit 1, tie bars, NW side, from S	1285/27

9. PHOTOGRAPHS cont'd

Figure No:	MTT Negative No
12b Main span, Trial Pit 1, tie bars, SE side, from W	1285/30
13a Main span, SW seating plate, end opened up, from SE	1286/20 ^A
13b Side span, SE fascia, from S	1287/25 ^A
14a Side span, underside, general view from SSE	1285/22
14b Side span, soffit plates, from SE	1287/19 ^A
15a Side span, NE seating from W, showing encrustation	1287/24 ^A
15b Side span, underside, jack arch and soffit plates at north corner, from SW	1287/18 ^A
16a Side span, Trial Pit 2, general view from south west	1286/8 ^A
16b Side span, Trial Pit 2, spacer plate, tie bar and nut, from S	1286/10 ^A
17a Side span, Trial Pit 2, general view from north east	1286/15 ^A
17b Side span, Trial Pit 2, end of girder and corner of soffit plate, from S	1286/13 ^A

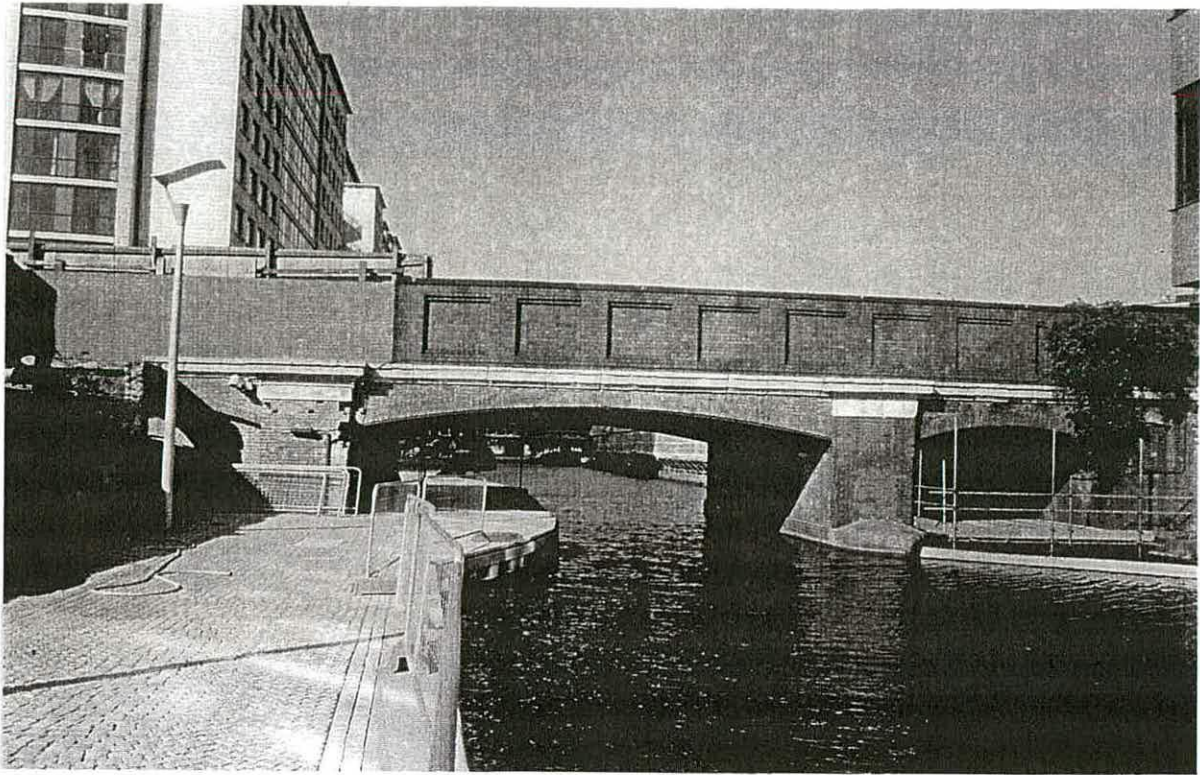

General view from SE

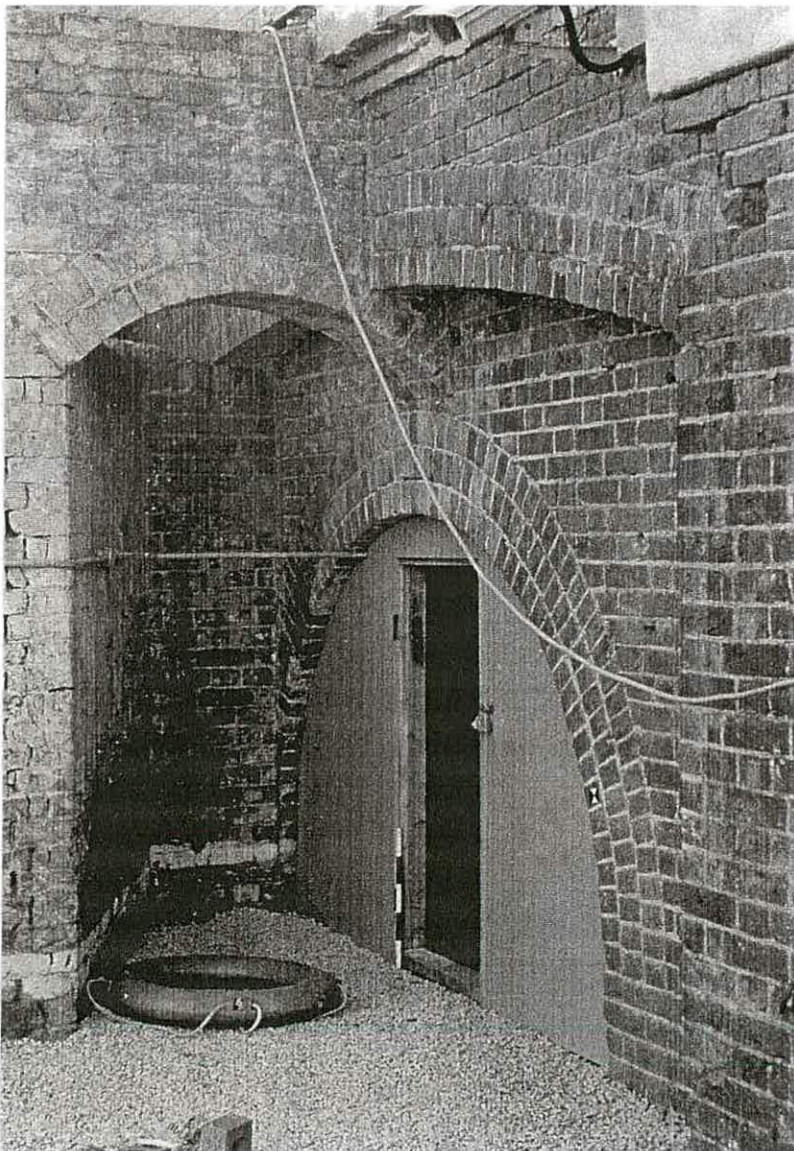

Land span from E

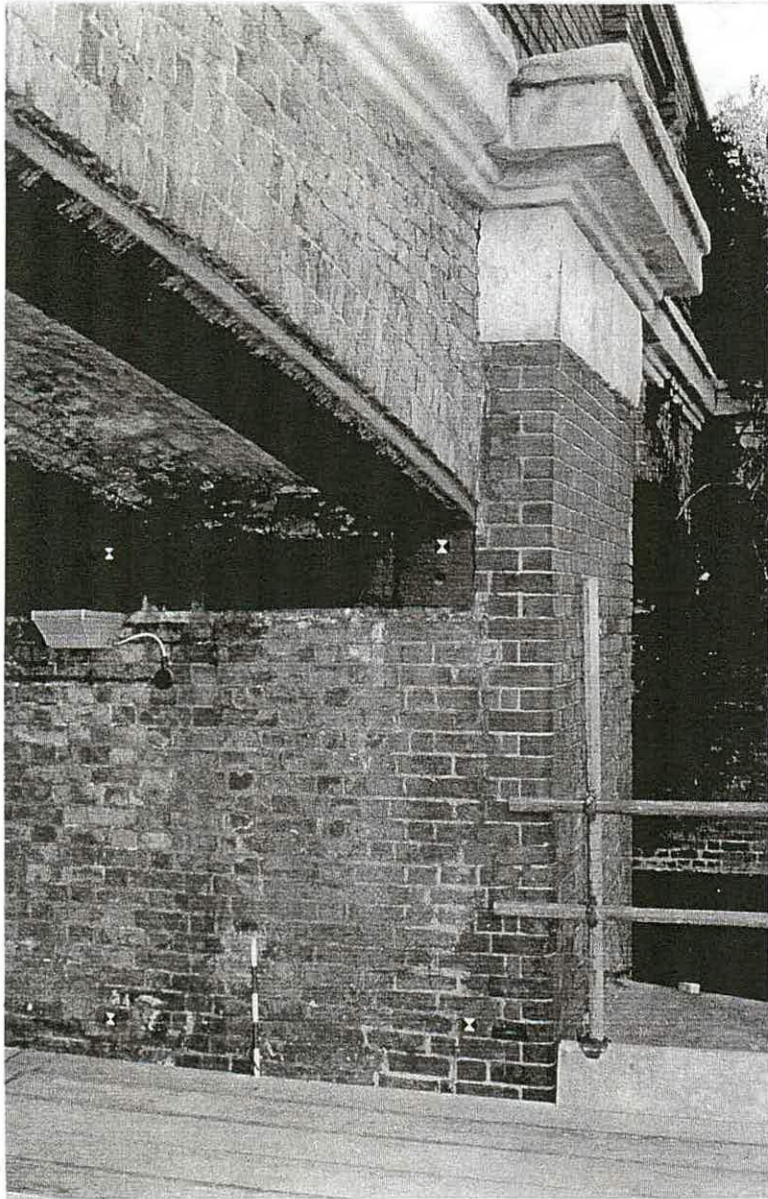

Mid-canal pier, SE end from S

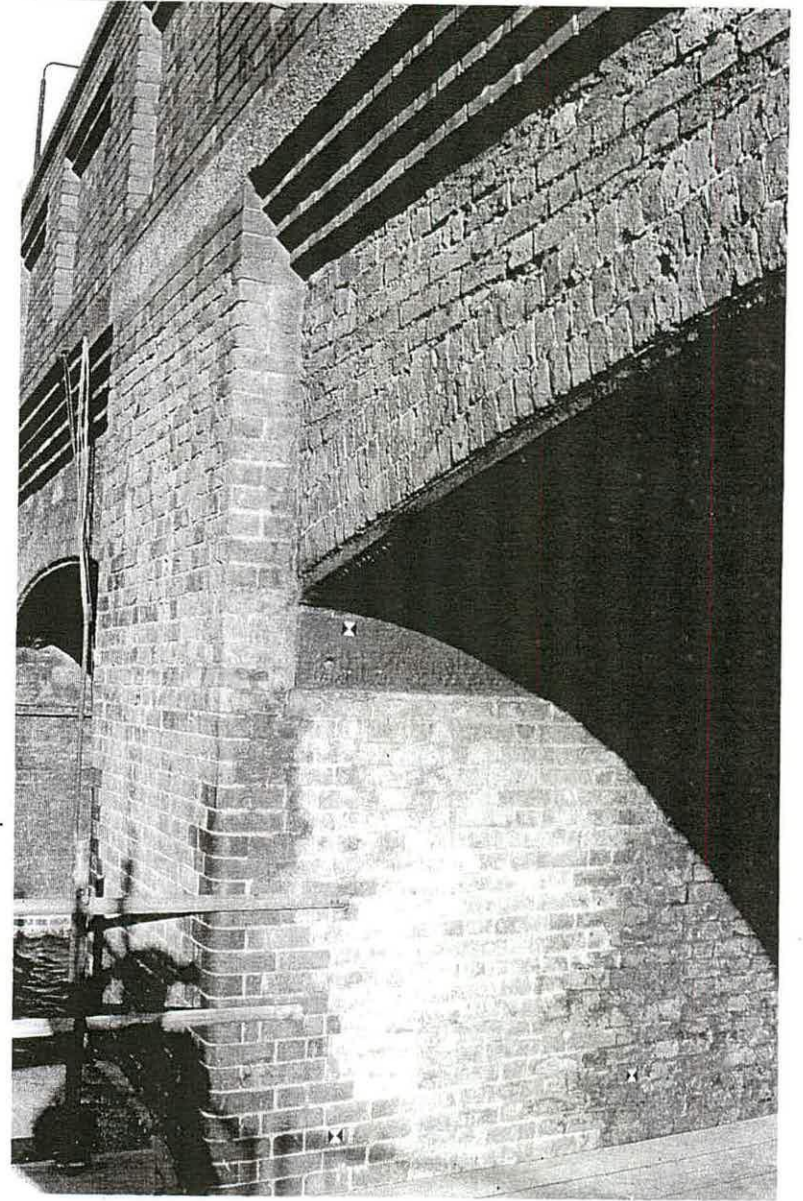

Mid-canal pier, NW end from W

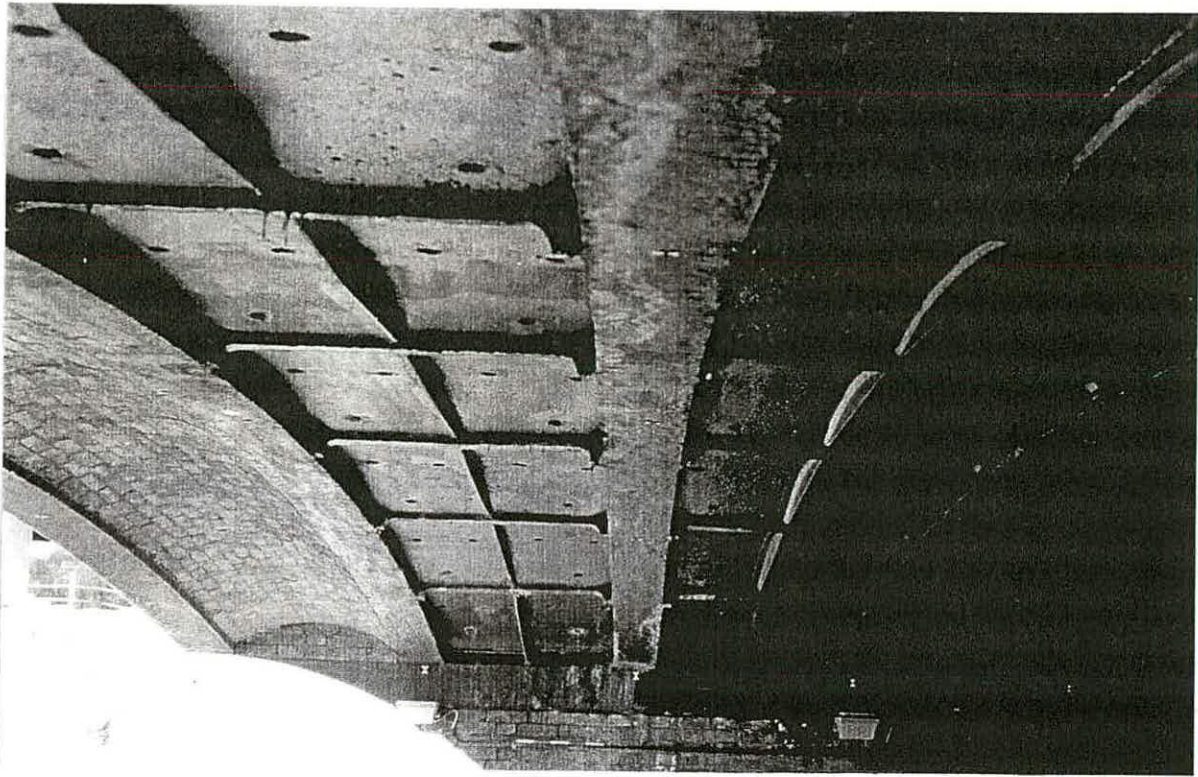

Main span NWside
underside from SW

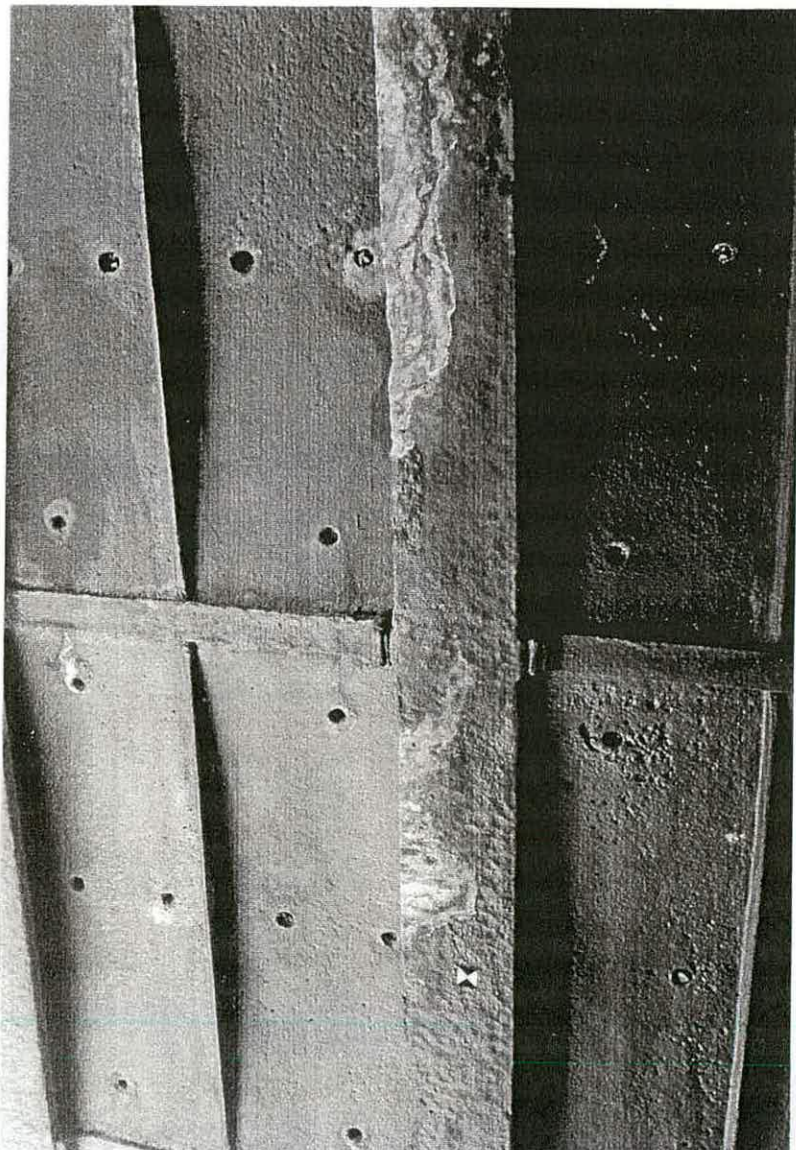

Close view of
Main span soffit NW side

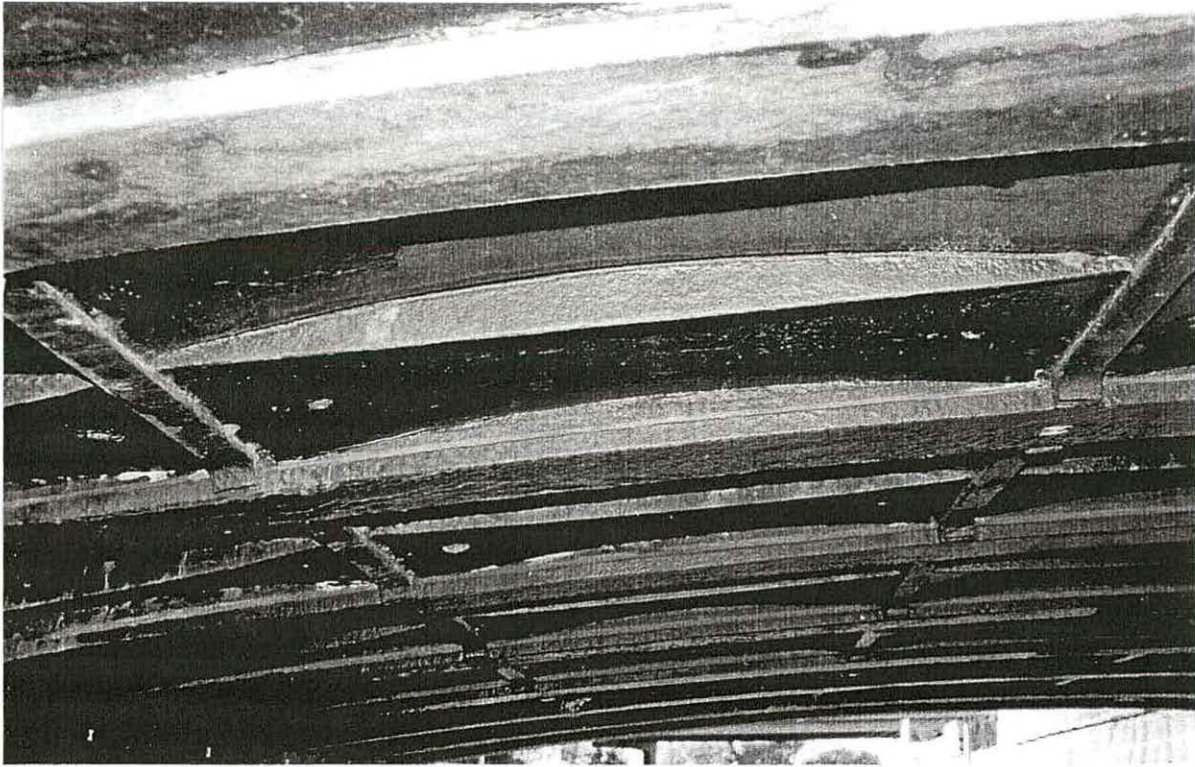

Main span, soffit plates from SE beneath TPI

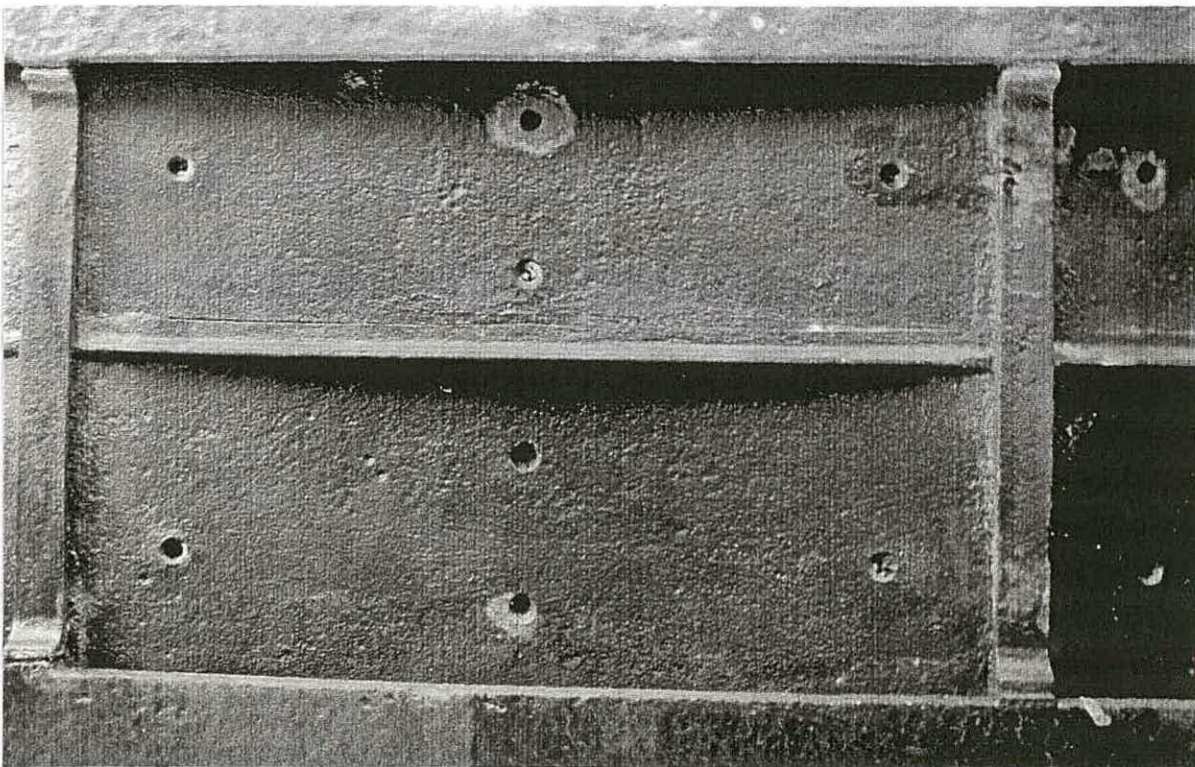

Main span, soffit plates in NW half from below

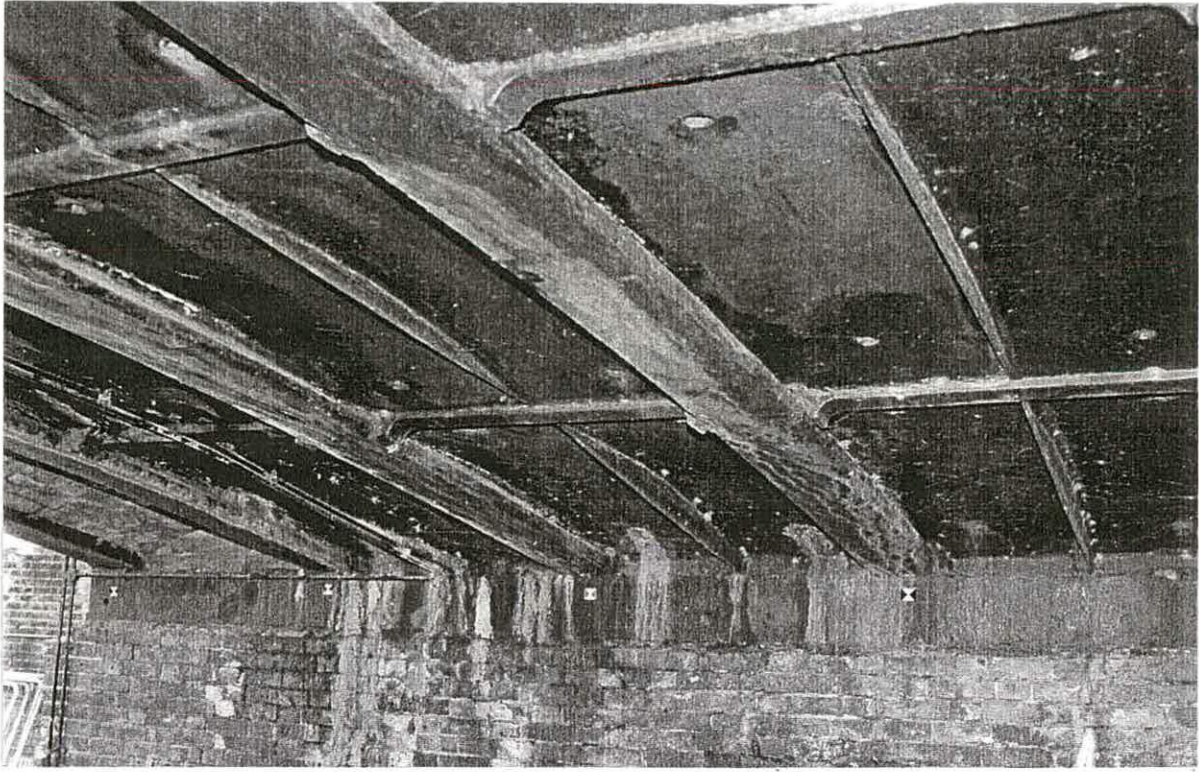

Main span soffit beneath TPI
from north

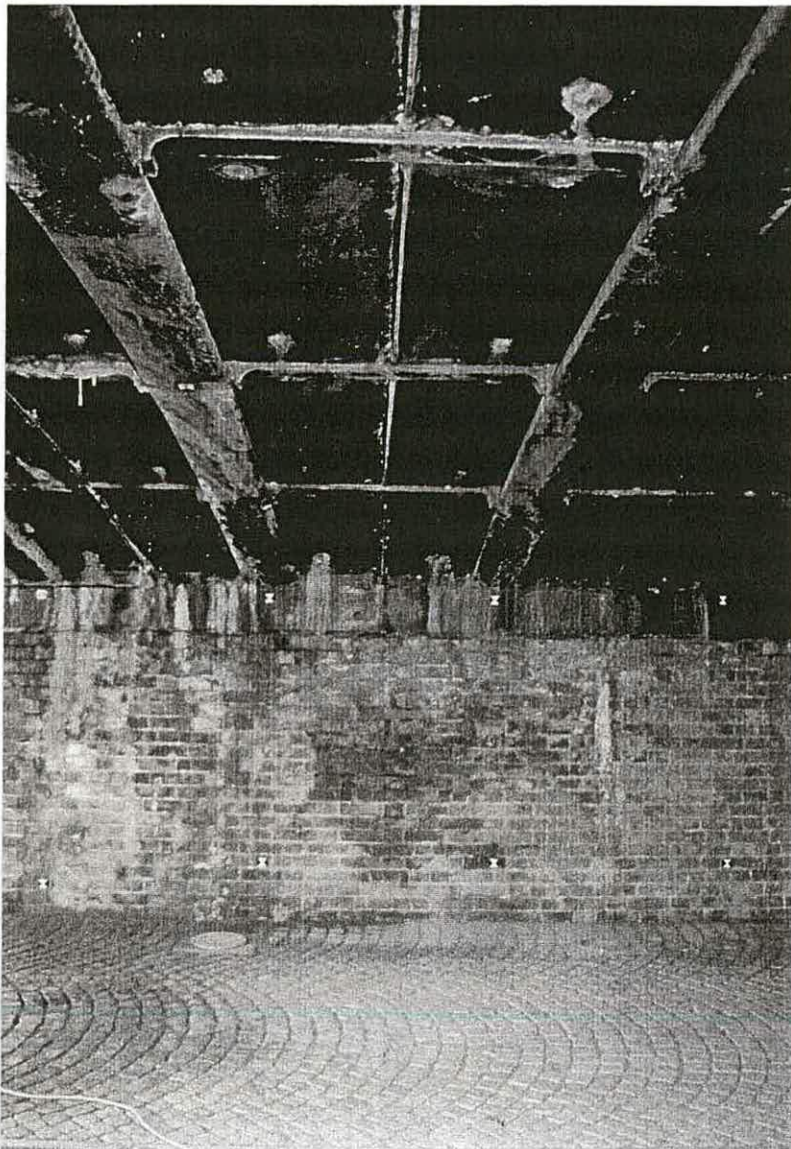

Main span soffit and seating
beneath TPI from NE

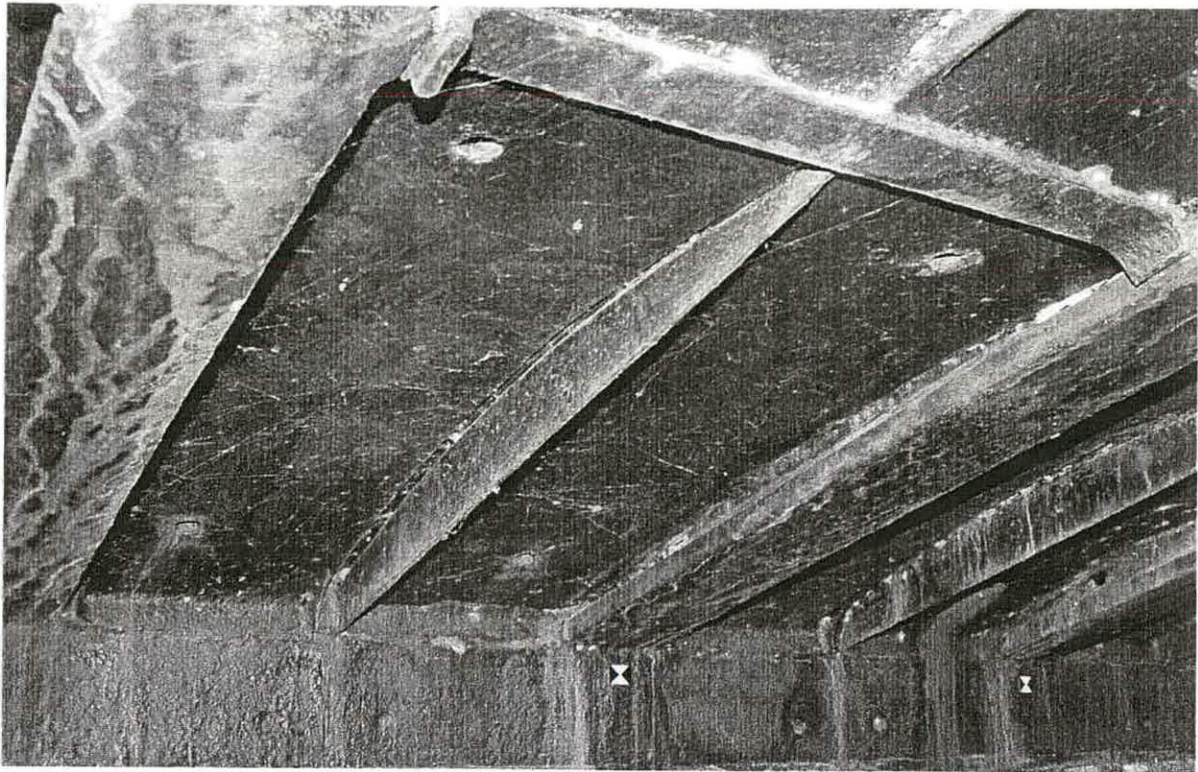

Main span, soffit adjoining seating on SW side

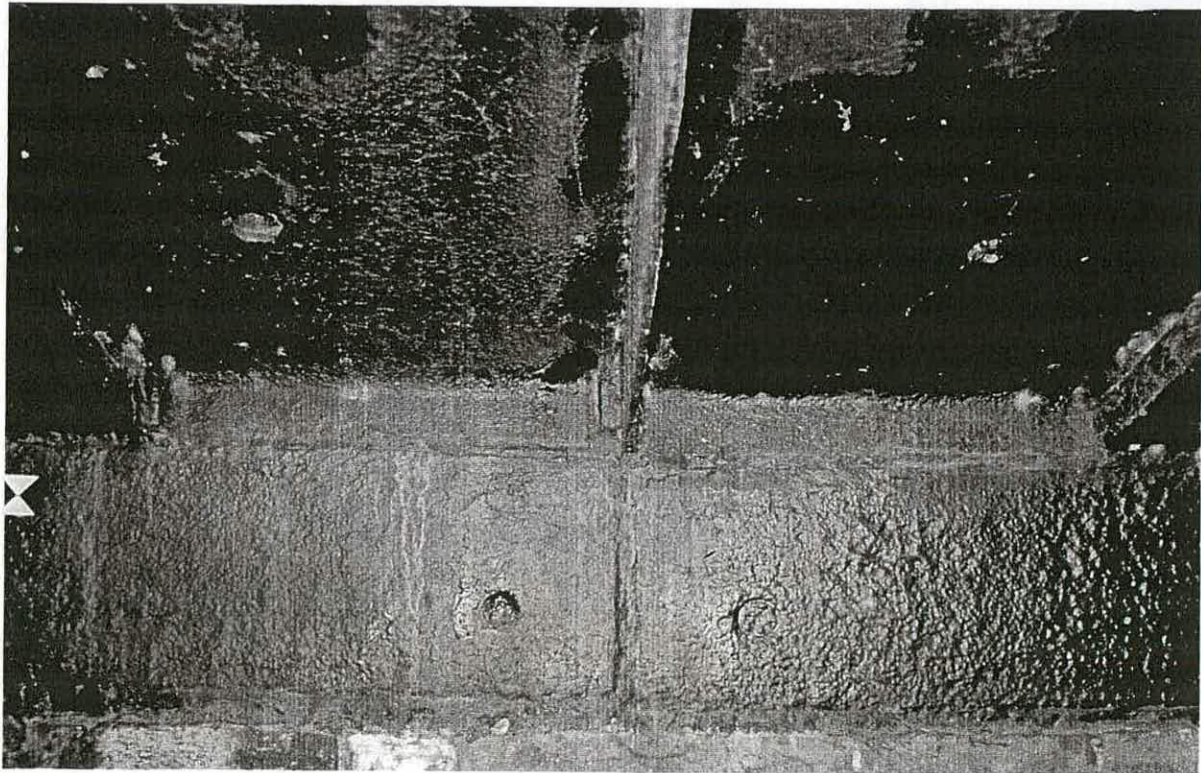

Main span, close view of seating on SW side

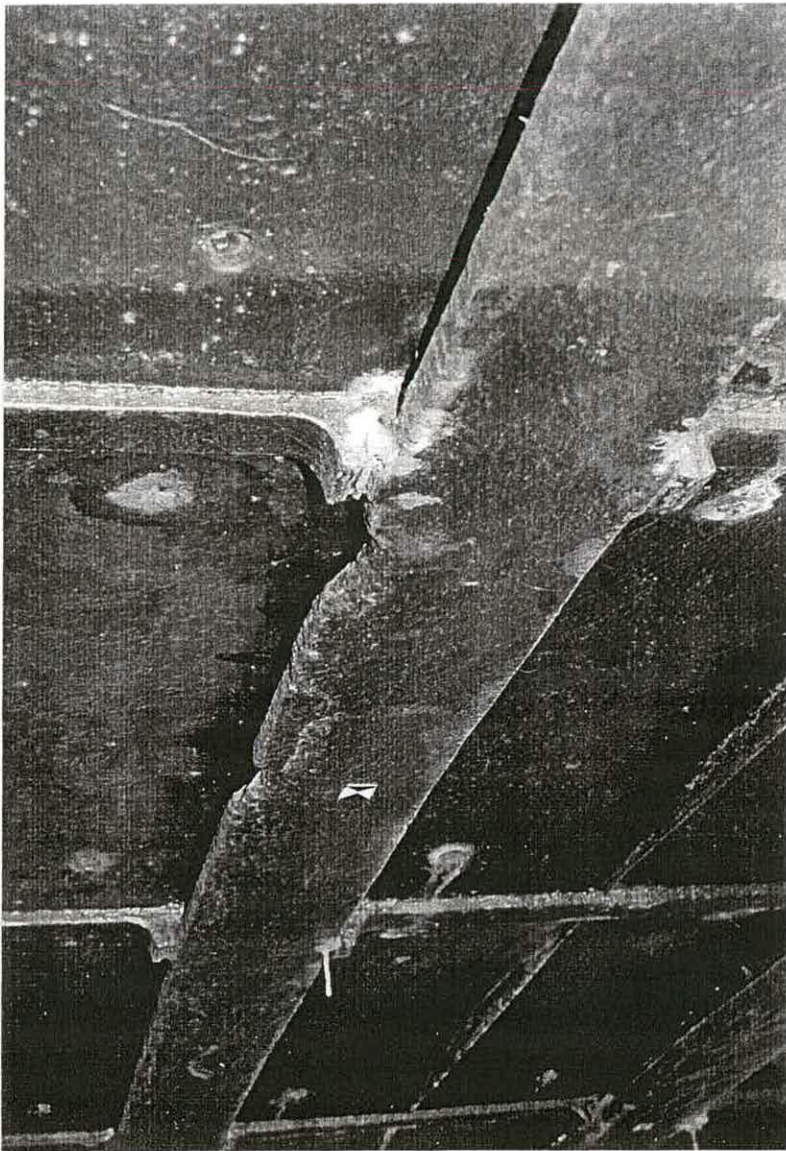

Main span girder with defects
in one flange.

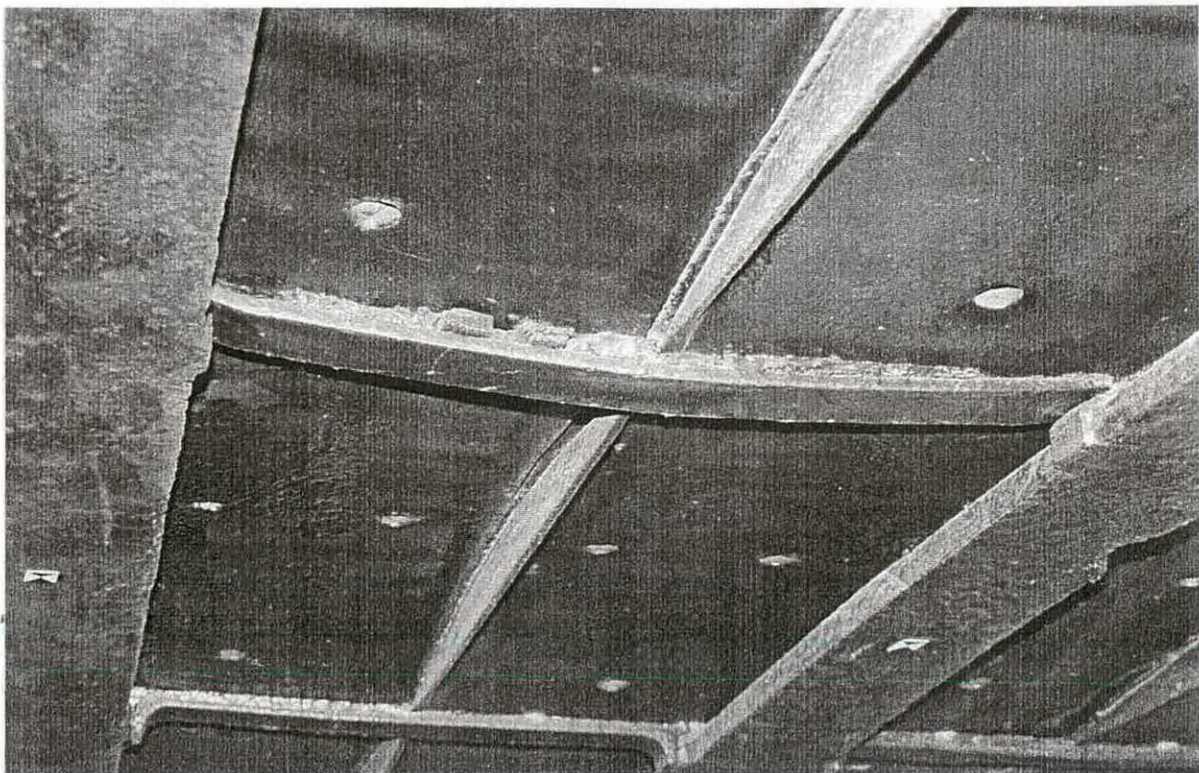

Main span, cross beam replaced

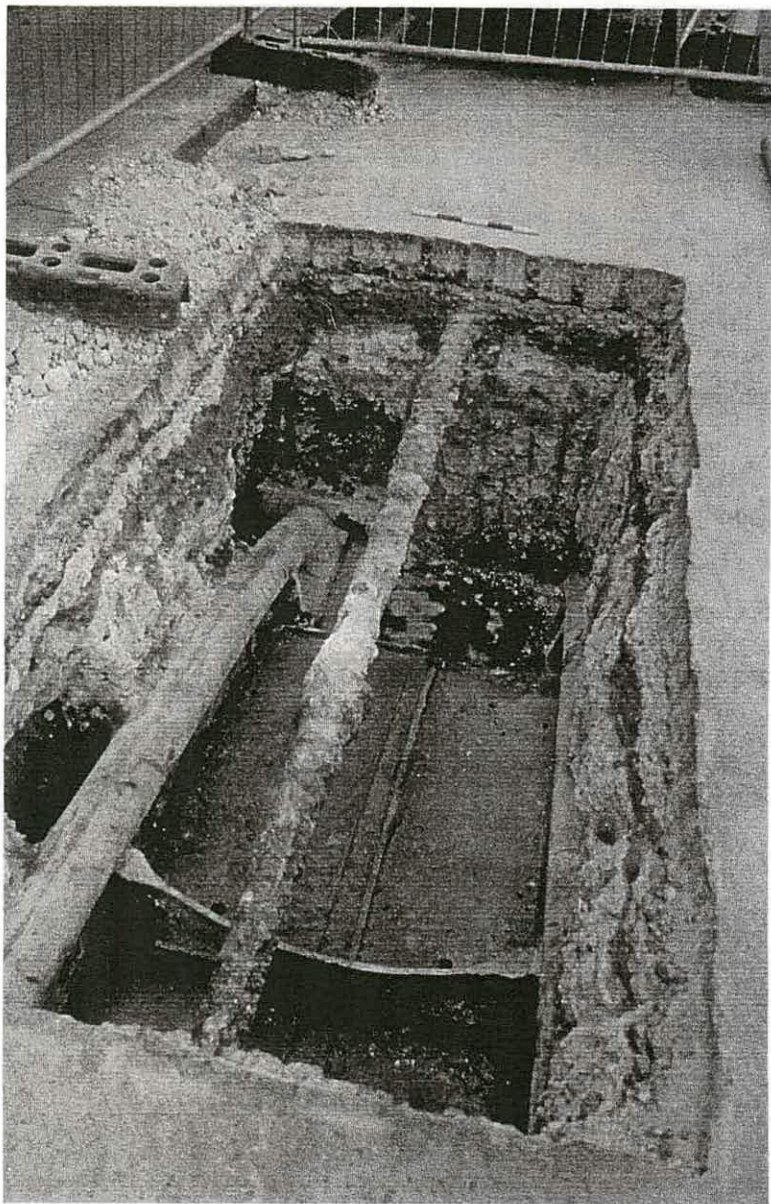

Main span, TPI from NE



Main span, TPI from WSW

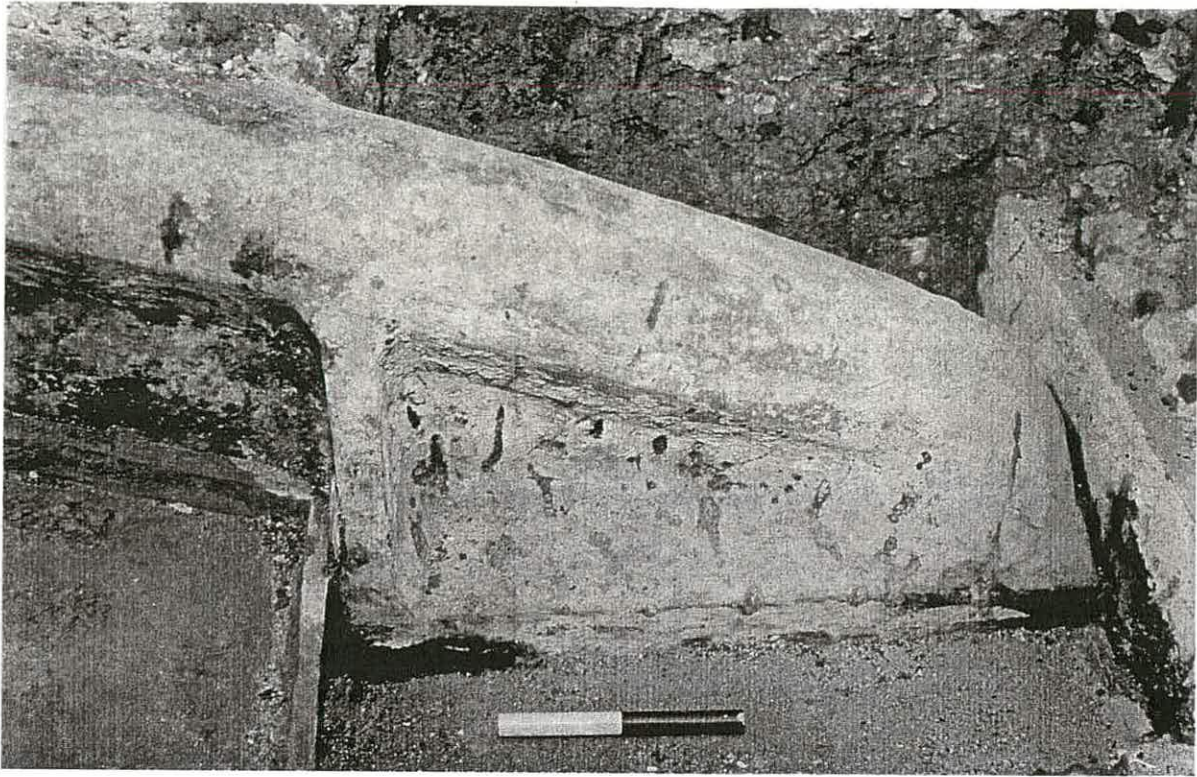

Main span, end of girder

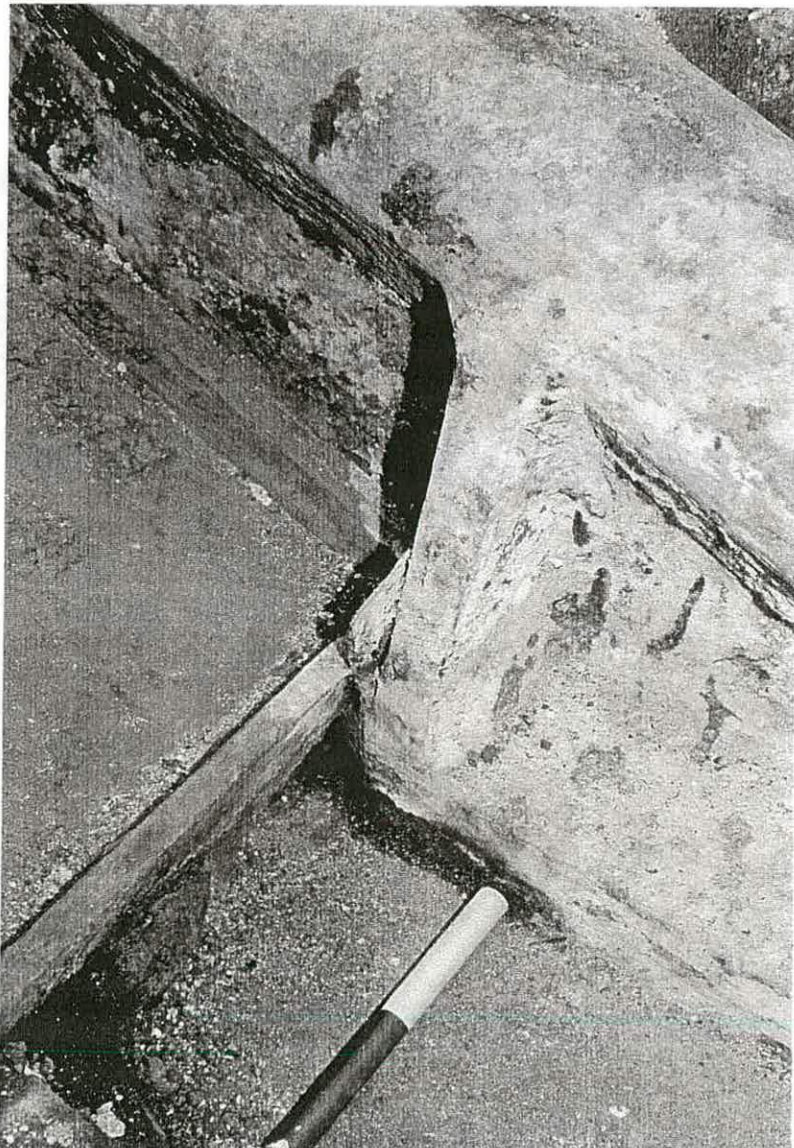

Main span girder,
stiffener and wedge

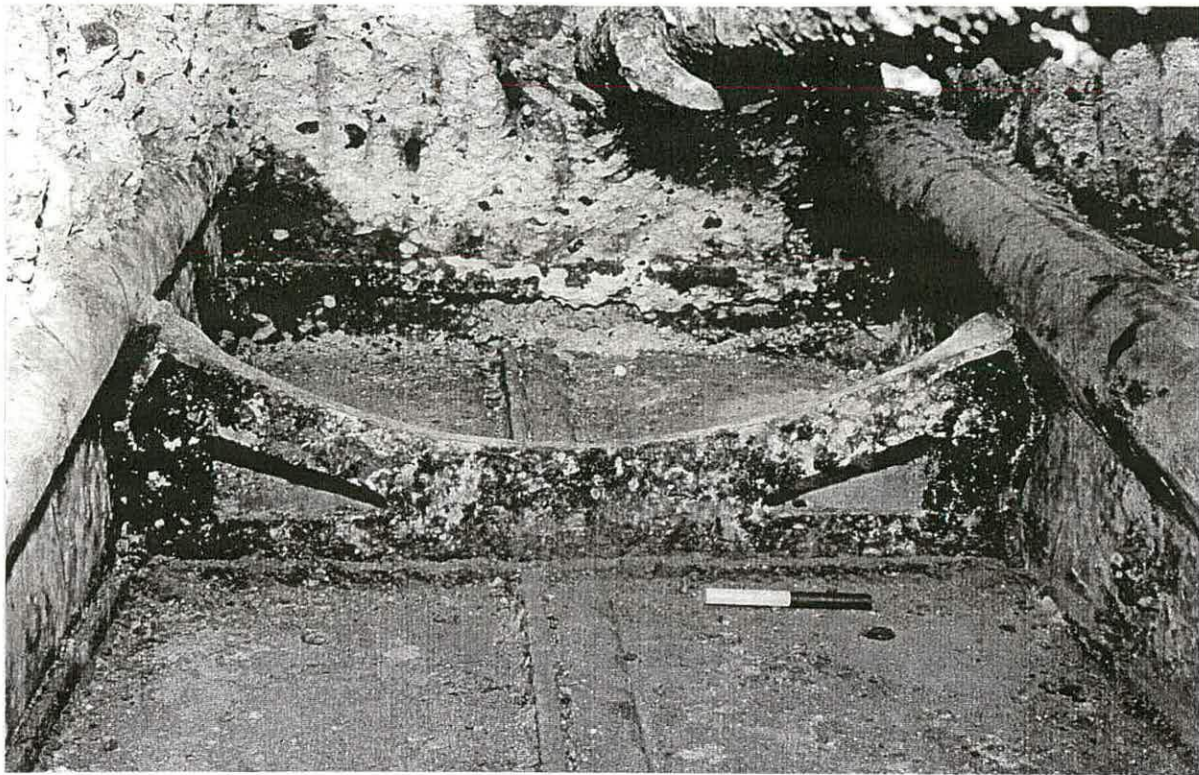

Main span, crossbeam and tiebar beyond.



Main span, wedge in joint of soffit plates

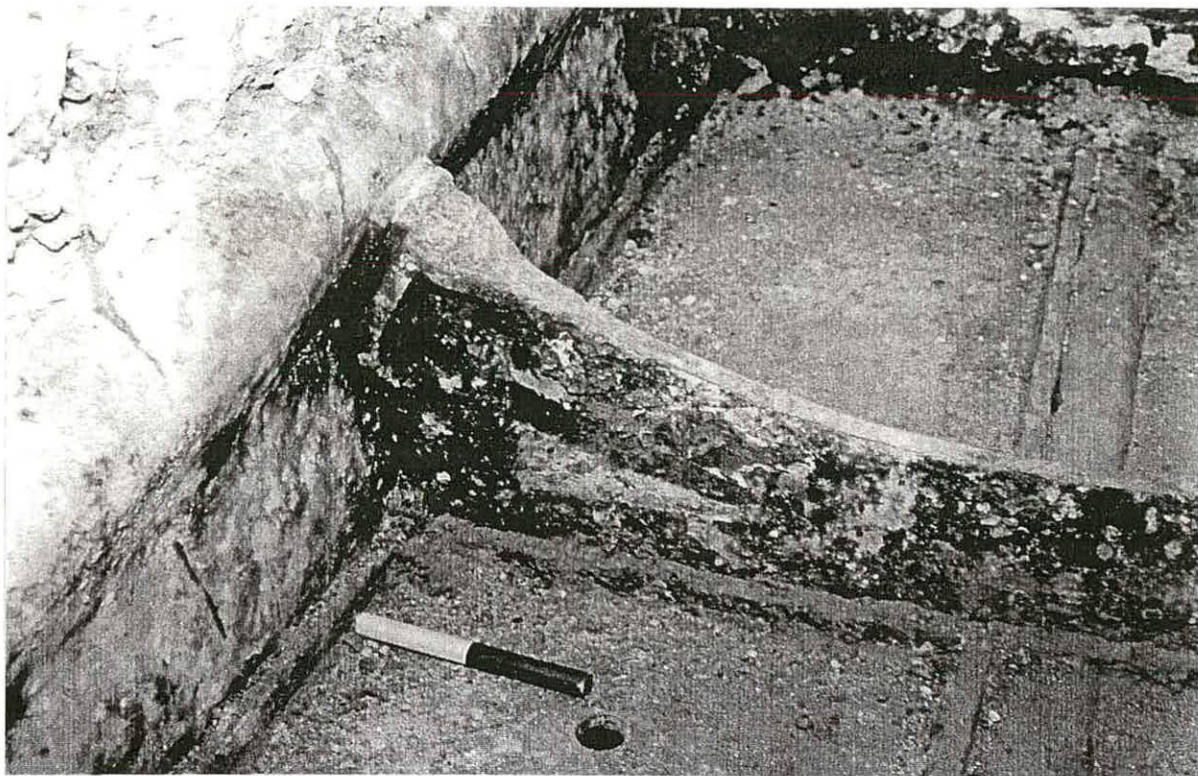

Main span crossbeam NW end



Main span crossbeam SE end



Main span tie bars NW side



Main span tie bars SE side



Main span, SW seating plate end opened up, from SE

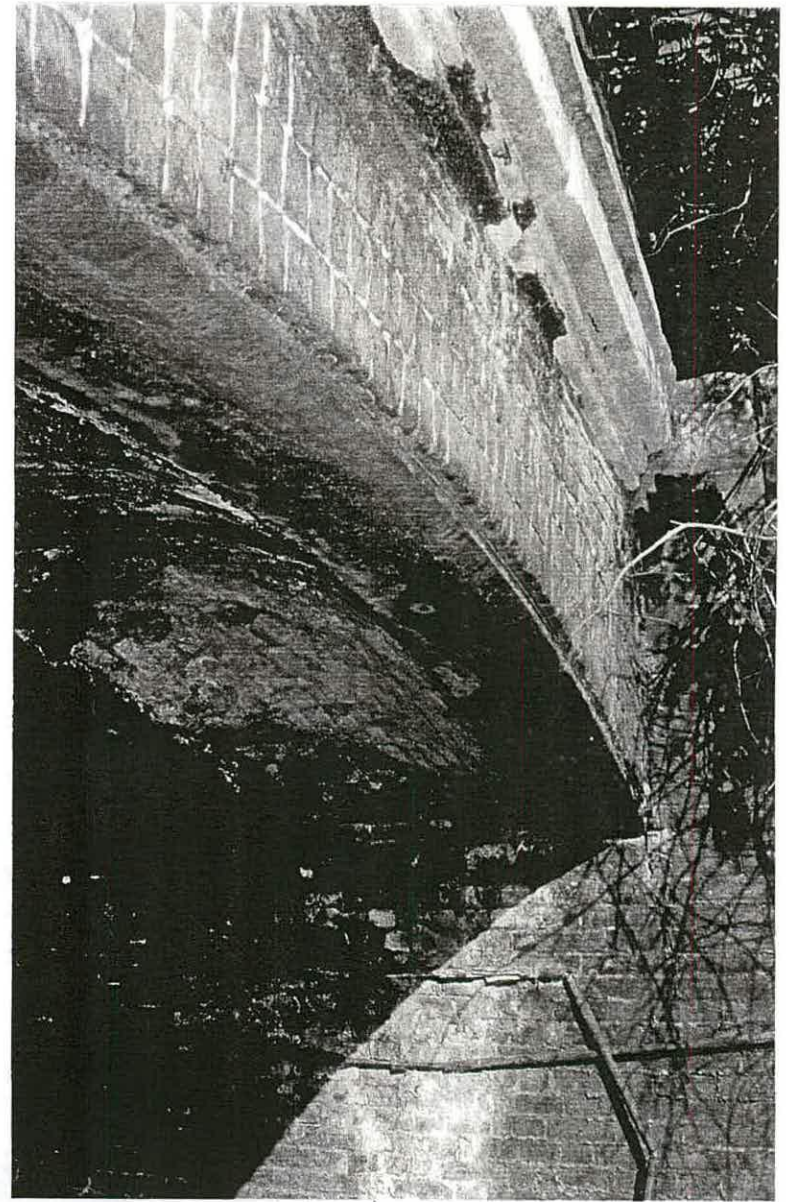

Side span, SE fascia from S

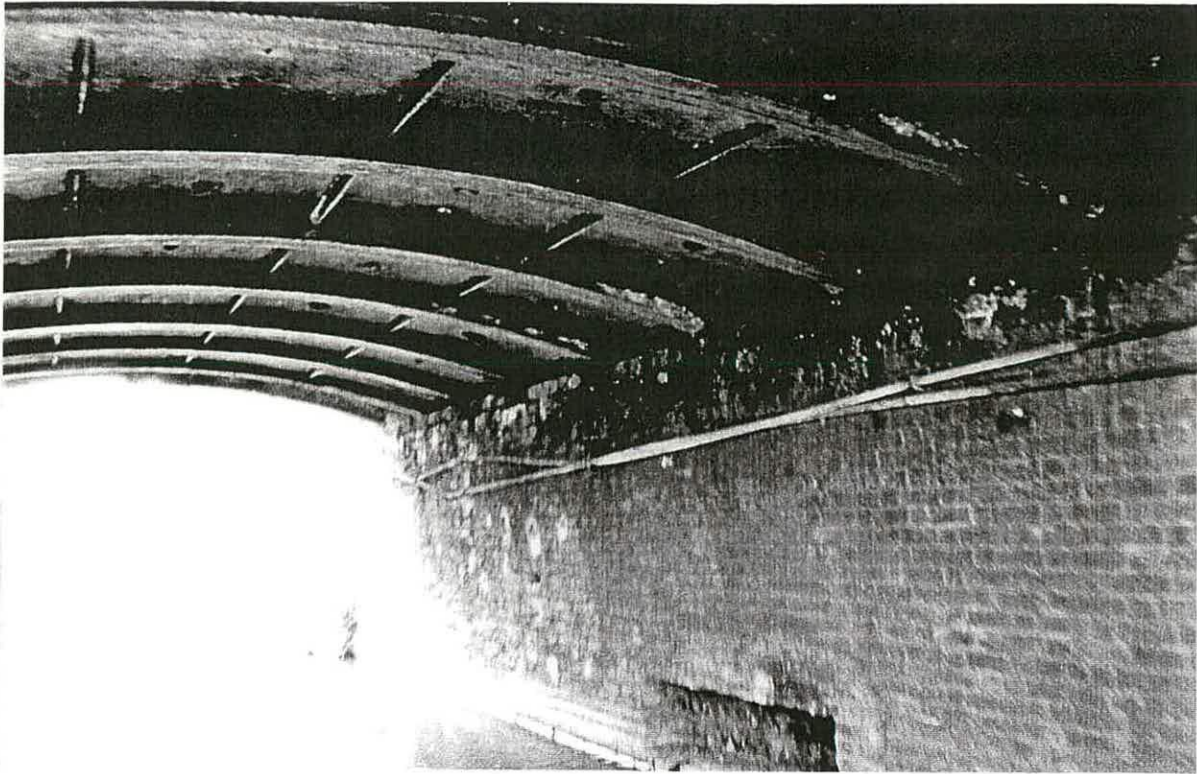

Side span underside from SSE

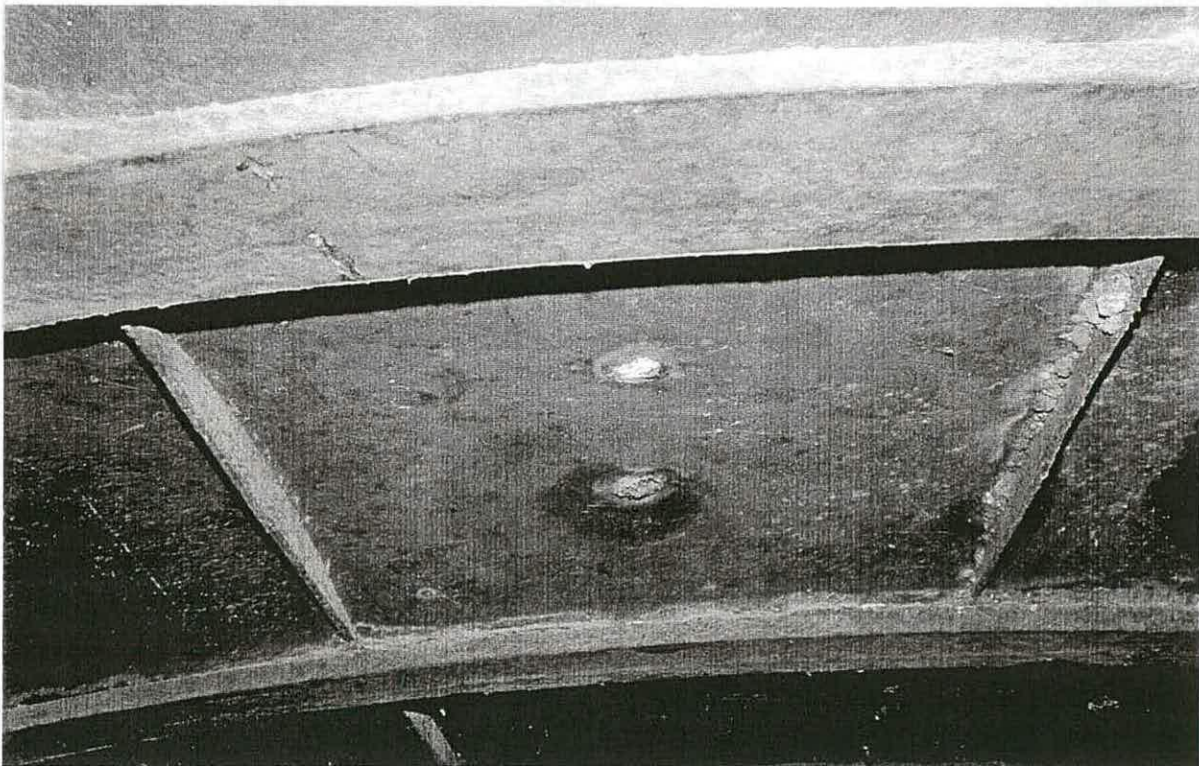

Side span, soffit plates from SE

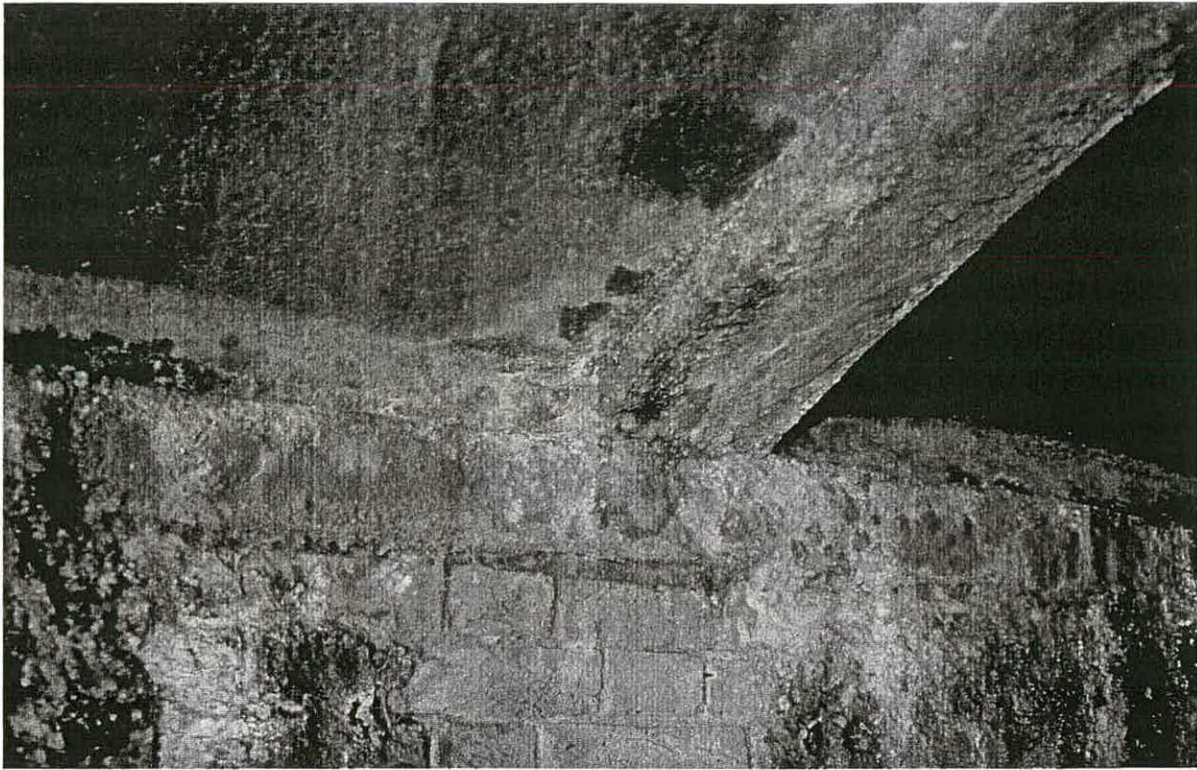

Side span, seating on NE side

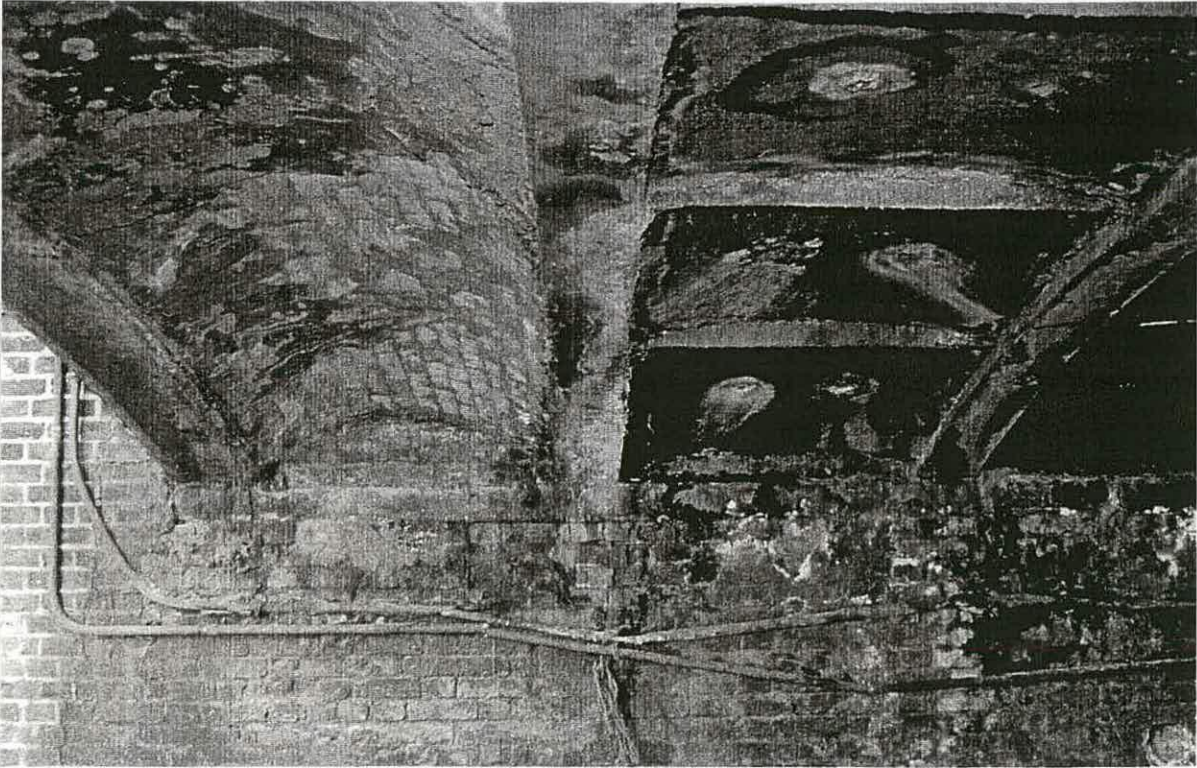

Side span, underside at N corner



Side span, TP2 from SW



Side span, spacer plate tie bar and nut from S



Side span, TP2 from NE



Side span, end of girder and corner of soffit plate from S