Middle to Late Iron Age settlement and a Roman palisade at HMP Littlehey, West Perry, Cambridgeshire

Jim Brown

With contributions by Dana Challinor, Andy Chapman, Pat Chapman, Karen Deighton, Tora Hylton and Yvonne Wolfram-Murray

Excavations in advance of development for the new young offenders' institution identified Iron Age and Roman remains. A possible watering hole was established for livestock on unenclosed upland pasture, dated by AMS radiocarbon dating of maple wood to the third century BC. A sinuous ditch had partitioned the areas to either side of the watering hole by the second century BC forming an axial boundary upon which subsequent developments were aligned. There was an increase in pottery deposition and by the first century BC an enclosure, subdivided by a fence and containing scattered internal pits, lay east of the boundary. The fragmentary remains of two possible roundhouses lay to the west. A pond and a well provided water until the early first century AD when straight boundaries replaced the sinuous ditches of the Iron Age but retained the site orientation. By the late first century AD a palisade enclosure was established and smaller utilitarian enclosures lay nearby. Early Roman domestic occupation may have been present within the palisade. Scattered pottery probably accumulated until the late second century and comprised mainly utilitarian jars and bowls in mundane fabrics. Abandonment took place before the mid-third century when the land probably reverted to rough grazing.

Introduction

Northamptonshire Archaeology carried out an archaeological excavation on the former sports fields at HMP Littlehey, West Perry, Cambridgeshire (NGR TL 1500 6595, Fig 1). The work was carried out for Wates Construction acting on behalf of the Ministry of Justice and was co-ordinated by CgMs Consulting Ltd. Excavation was required by Cambridgeshire Archaeological Planning and Countryside Advice (CAPCA) and followed a specification prepared by CgMs Consulting Ltd (Thomas 2008; Gajos 2009). The results of the excavation were assessed and a further program of analytical work was recommended (Field and Yates 2009, 18–19). This article is based upon the planning report that was submitted to CAPCA and will be available digitally on the Archaeology Data Service (ADS) website <http://ads.ahds.ac.uk/catalogue/library/greylit>

The site comprised 0.89ha of relatively flat enclosed

playing field at c. 50m above Ordnance Datum. It lies upon a low ridge between the valleys of the River Kym and Diddington Brook, the latter now dammed to create Grafham Water reservoir. Both are tributary valleys of the River Great Ouse with gently rolling low valley sides and fairly broad floodplains. West Perry lies to the north and the village of Great Staughton lies to the south-west. The parish boundary between the two follows the southern perimeter of the site (Fig 1).

The underlying geology of the site comprises Oxford Clay and Kellaways Beds (British Geological Survey 2001). The soils are of Hanslope Association which tends to be calcareous clayey soils with some risk of water erosion (Lawes Agricultural Trust 1983).

CgMs Consulting Ltd undertook an archaeological desk-based assessment that consulted the Huntingdonshire Archives (CRO), Huntingdon Local Studies Library and Cambridgeshire Historic Environment Record (HER) (Gajos 2008, 4). An undated flint scatter was located 600m to the north-east (HER00485) associated with a former earthwork (HER00485a). A Roman road lay 1.2km to the north-east (HER00506). A mixed cremation/inhumation cemetery, a pottery kiln and various metal-detecting finds were also fairly distant. West Perry was recorded in the 1086 Domesday Survey (Harvey 1975). Saxon brooches and strap ends have been found in the parish by metal detector. Gaynes Hall in West Perry was a medieval moated manor (HER00477) and another was located at Manor Farm (HER00478). Traces of the open fields survive at Manor Farm (HER11366), Crow Spinney (HER11603) and Gaynes Lodge Farm (HER11604). HMP Littlehey lies within a thirteenth-century park that belonged to the Gaynes Estate (Way 1997). Documentary evidence of the thirteenth-fourteenth centuries refers to 'Littlehey Park', although its exact location is speculative.

The current Gaynes Hall is a Grade II* Listed Building redesigned by George Byfield, c. 1800, incorporating elements of seventeenth century date (Pevsner 1968). Gaynes Park was recorded in the seventeenth century, covering 256 acres, east of the hall. In the nineteenth century this was extended further to the west (Way 1997). An estate map of 1801 shows the north part of the development named sheepwalks

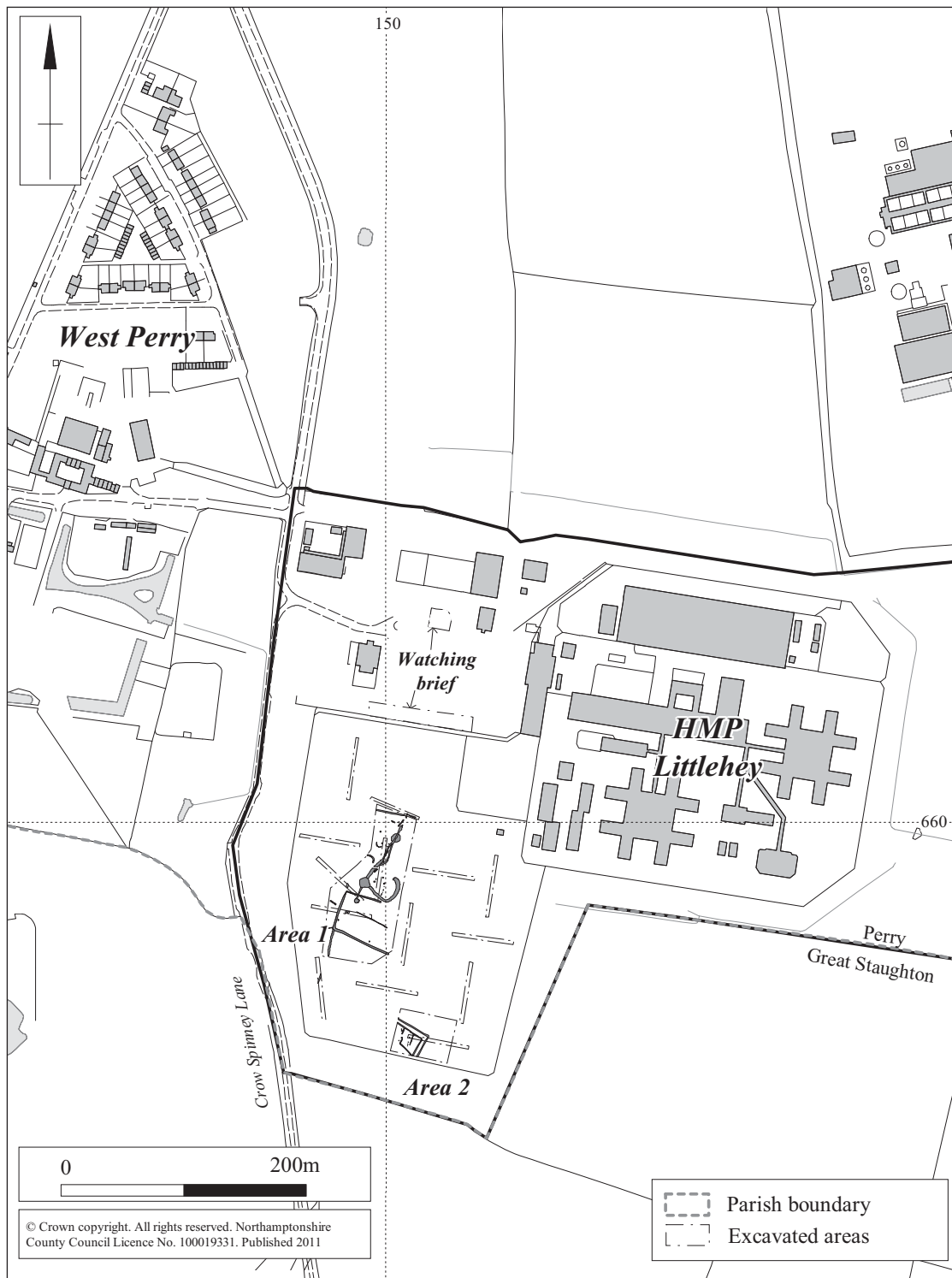

Figure 1. Site location.

(CRO38/22). The Inclosure map of 1807 shows a disused duck decoy pond at Crow Spinney (HER0487). Ordnance Survey maps since 1835 depict the progressive development of enclosed parkland, used for agriculture, up until the Second World War. Gaynes Hall was requisitioned during the war for use by the Special Operations Executive, Station 61. It functioned

as headquarters and billet for air liaison officers and agents. After the war the hall became the administrative office and residence of the governor for Gaynes Hall borstal. Ordnance Survey maps show the borstal layout from 1952 onwards, and minor extensions between 1970 and 1980. The borstal was replaced by the current Category C men's prison in 1988.

Disturbance from the construction of the borstal in the 1950s and subsequent levelling for the sports field was anticipated (Gajos 2008, 14). There had been no archaeological work prior to the watching brief during a survey seeking unexploded ordnance (Fig 1). This was followed by trial excavations which revealed Iron Age and Roman remains likely to be affected by the construction works (Northamptonshire Archaeology 2009).

The excavation of Area 1, 0.57ha in extent, was targeted upon features associated with a principal boundary of Iron Age date, with overlying Roman occupation, and Area 2 examined an area of 0.17ha, containing an ancillary Roman enclosure. Topsoil, subsoil and modern overburden were removed by a tracked excavator, fitted with a toothless ditching bucket, working to the surface of the archaeology or, where this was absent, the natural substrate (Fig 2).

The archaeological remains fell into four periods, grouped by character and date, summarised in Table 1.

Table 1. Summary of site chronology.

Period (date)	Nature of activity
Neolithic to Early Bronze Age	Residual flint in Iron Age contexts
Middle to Late Iron Age (third century BC – early first century AD)	An enclosure and two possible roundhouses with domestic pottery and quern fragments lay adjacent to a pond and axial ditch, colonised with field maple and blackthorn
Roman (late first – second centuries AD)	Straight ditches replaced existing overgrown or silted boundaries, a palisade enclosure and scattered pottery formed the focus of occupation supported by ancillary enclosure nearby
Roman disuse (mid-second – third centuries AD)	The site was abandoned and left to regenerate, ditches silted naturally and the land probably reverted to rough grassland

Residual Neolithic to Early Bronze Age worked flint

The worked flint was examined by Yvonne Wolfram-Murray. There are six flint flakes, of which two are broken, recovered from Iron Age contexts. The flint is in good condition with little post-depositional edge damage. The source of the raw material is the local gravel. Technologically, the artefacts do not conform to a particular period and date from the Neolithic to the Early Bronze Age.

Middle to late Iron Age settlement

Initially the land was probably unenclosed and was occupied by a single large pond during the third century BC, which may have served as a watering hole for livestock (Fig 3, watering hole 3077). By the second century BC a ditch aligned on the watering hole formed an axial division, north-east to south-west.

Enclosure E1 was added to the south-eastern side of the boundary, surrounding an area that contained scattered pits. To the north-west lay the fragmentary remains of two roundhouses, R1 and R2.

Study of animal bone, by Karen Deighton, indicated that fragmentation and abrasion were fairly high, together with canid gnawing. Butchery knife marks appeared on a single cattle bone. The site supported a small range of common domesticates with the dominance of cattle in the late Iron Age, together with some sheep/goats. Moderate preservation, fragmentation and little ageing or metrical data made further interpretation impossible.

The pottery, examined by Andy Chapman, comprises 691 sherds, weighing 5.27kg, from hand-built vessels dating to the middle to late Iron Age. The average sherd weight is 7.6g, typical of assemblages from smaller Iron Age settlements in the South Midlands that contain a high proportion of shelly ware, which is typically soft, prone to leaching, and usually highly fragmented and abraded. The coarse shelly fabric makes up over a half of the assemblage and these sherds often derive from thick-walled jars. The fine shelly wares make up a further 15% of the assemblage. The sandy fabrics form 20.4% of the total and occur in small numbers in a wide range of contexts. The grog ware is only 5.6% of the assemblage by sherd count, and has a limited distribution, which is discussed below in relation to the site chronology.

The assemblage is dominated by body and base sherds. There are a limited number of rims, and when present these are usually very fragmentary. They are typically simple upright rounded or flattened rims. There are few joining sherds and many small groups. It is not possible to define vessel forms, but the likely range can be inferred by reference to other contemporary assemblages. It is suggested that the assemblage was dominated by medium and large jars with the presence of some smaller jar or bowl forms in fabrics containing either fine crushed shell, sand or a mixture of the two.

Possible watering hole

Watering hole 3077 was 7.2m wide and 2.55m deep. The profile showed a gradual slope along its east side that may have allowed animals to drink (Fig 4). The slope steepened towards the deepest part and had a flattish slightly concave base. The west side was too steep to serve a similar purpose, a difference that may relate to the land use on either side of the watering hole. Merging gleyed layers of mottled grey to greyish-brown clay silt filled the watering hole representing sequential deposition of waterborne sediment.

The watering hole lay at a low point of the site and was a natural collection point, made more efficient by the subsequent addition of ditches. It received some maintenance during its use as the uppermost fills were contemporary with ditch fills and recutting of the ditches had clearly necessitated cleaning out and digging at the edges of the watering hole on more than one occasion.



Figure 2. Area 1 excavations facing north-west.

The lowest sediments were waterlogged and contained dark grey silt 3076 from which four large pieces of roundwood were recovered, together with six sherds of pottery, weighing 21g. The wood was identified by Dana Challinor as boughs from a mature field maple. A sample of wood from this fast growing species was submitted for radiocarbon dating and has given a date of 400–200 cal BC (98% confidence, 2250±40BP, Beta-270497). As with all radiocarbon dates in the middle Iron Age there are two possible date ranges at the 68% confidence level, 390–350 cal BC and 290–220 cal BC, with the third century option having the higher probability at over 40%.

The combined sediment layers produced 62 pottery sherds, weighing 417g, spanning the middle to late Iron Age with distinctive later sherds from the highest levels. These mainly comprised plain body sherds, with several sherds from scored ware vessels, typically large, thick-walled jars, up to 13mm thick. These are characteristic of middle Iron Age assemblages in the South Midlands. A rim sherd has fingertip decoration immediately below the rim, which is characteristic of the early part of the middle Iron Age, while the presence of smaller, finer, bowls that are typically black throughout and often with smoothed or burnished surfaces, would suggest a date late in the use of scored ware. The scoring comprises crudely executed lines running obliquely down the vessels in roughly parallel lines.

Principal boundary

This axial boundary comprised a series of discontinuous elements along a north-east to south-west align-

ment (Fig 3). The initial cut was probably ditch 3069, subsequently recut in an eastward progression by ditch 3054 at a time after the water hole had already substantially silted up. The alignment of the boundary continued to the north of the pond as a series of short lengths of gully.

To the south-west a single sinuous ditch formed the boundary, somewhat irregular in plan, showing considerable variation in both size and shape. The original ditch was less substantial than later recuts. Ditch 3069 was 0.45m wide by 0.20m deep with a barely perceptible break of slope that dropped into a rounded base. Ditch 3054 was 0.87m wide by 0.23m deep with fairly shallow rounded sides. The ditches had been heavily truncated in the 1950s. Towards the south both ditches were deeper but suffered badly from vertical truncation, making them hard to trace. Ditch 609 was 1.2m wide by 0.50m deep and ditch 611 was 1.0m wide by 0.55m deep, both exhibited slightly eroded 45–50° sloping sides but had generally flat-topped bases. The fills suggested gradual silting, rather than deliberate infill with only seven pottery sherds in total, weighing 40g.

Settlement

The principal boundary was broadest in its central section where ditch 3204 was 1.9m wide and 1.1m deep with a steep-sided profile and broad rounded base. These larger dimensions were a result of the addition of Enclosure E1, which was open to the north and abutted the south-east side of the boundary (Fig 3). Internally, the enclosure was 23m by 16m, an area of 0.04ha. Ditch 3240 was 1.75m wide to the south and

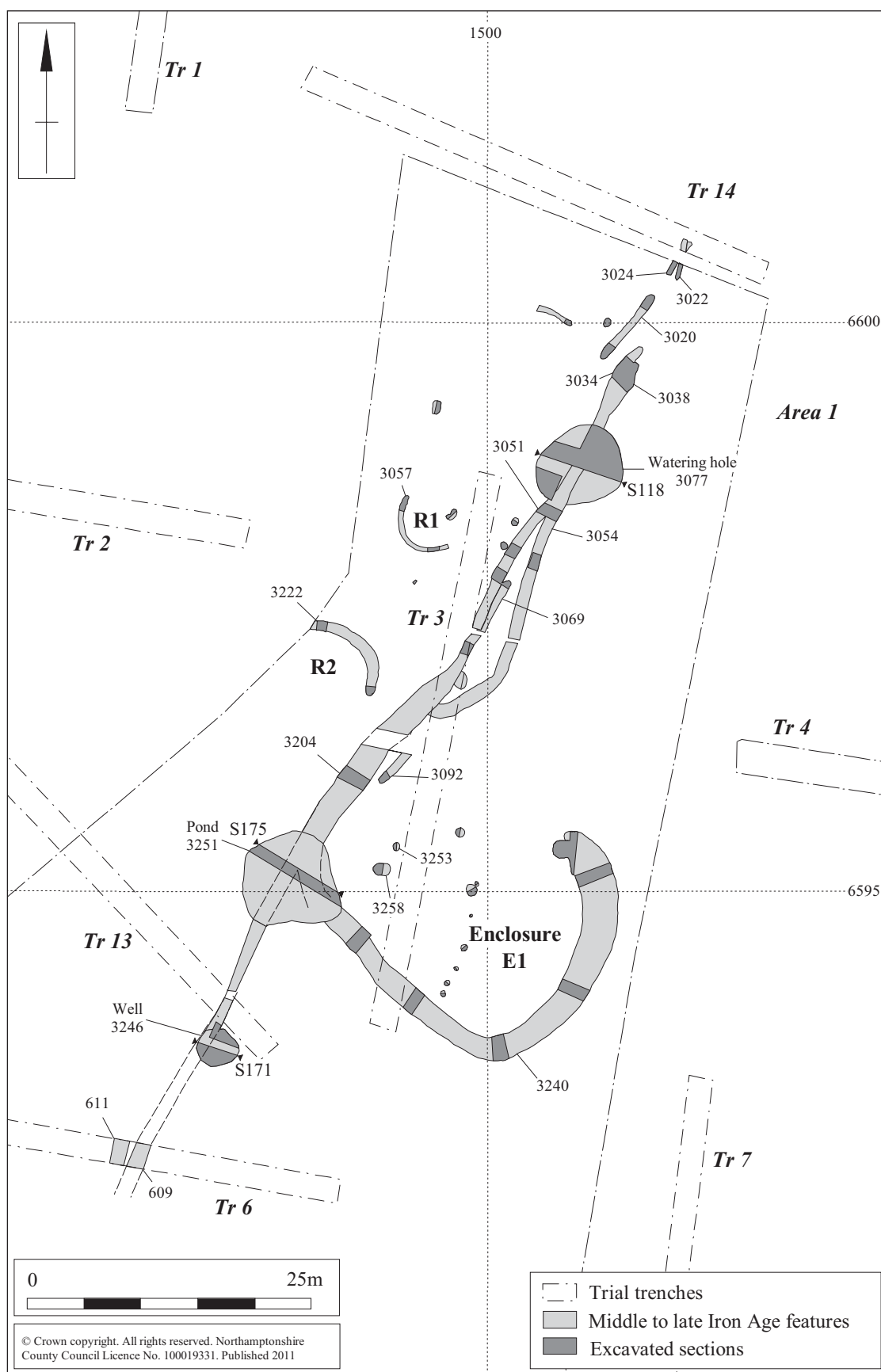

Figure 3. Middle to late Iron Age features.

widened to 3.50m to the east, with a typical depth of 1.0m throughout. The orange-grey silty clay fills, probably derived from material washed into the ditch combined with sporadic dumping of domestic waste in ditch 3204 that included a total 141 later Iron Age pottery sherds, weighing 2,124g, almost half the weight of the total assemblage. The group includes two large thick-walled scored ware jars, a small burnished bowl and a scored ware jar with latticework decoration on the body and regular finger-tip impressions around the rim (Fig 5). This more regular form of scored decoration has been seen at other South Midland sites in contexts dating to the first century BC.

Cattle, sheep or goat bone, and a possible coarse millstone grit quern fragment comprised the other finds. Seeds were preserved by charring and waterlogging and were examined by Karen Deighton. Fat hen (*Chenopodium album*) was the only wild/weed plant taxa present, there were four possible spelt grains (*Triticum aestivum*) which were fragmented and heavily abraded. A single pea (*Pisum sativum*) was also identified. The charcoal from enclosure E1 was examined by Dana Challinor and is likely to have derived from domestic fires deposited alongside other rubbish. The wood used for fuel is of hedgerow or scrub species. Ash and blackthorn are light-demanding, but buckthorn is shade-tolerant, so a range of habitats were represented consistent with the evidence from other Iron Age settlement sites where the use of scrub for fuel resources has been noted (Smith 2002).

Little can be said of the local environment of the site. The mollusca present indicate the presence of standing water, as does the presence of waterlogged wood in watering hole 3077. The amount of charred plant material is of a fairly ordinary level comprising material blown or washed into the features from activities elsewhere.

A line of six postholes partitioned the enclosure. The postholes were unevenly spaced, 1.0–2.7m apart, generally rounded, with steep near vertical sides and narrow rounded bases. Their dimensions were in the range of 0.25–0.5m wide by 0.11–0.18m deep. None of the postholes produced finds.

To the north-west of this partition were four discrete pits. The largest pit, 3258, was oval, 1.5m long by 1.0m wide by 0.28m deep. It had curving sloped sides that met in a rounded bowl-like base. The fill contained a slab of fired clay which is hard, cracked and easily fragments, 110mm by 90mm by 30mm thick, orange on one side and purple to black on the other. Pat Chapman examined the fired clay and considered it to be the lining from around a hearth or other heated surface that has survived in a clump rather than as fragments. The pit also produced 12 pottery sherds, weighing 49g. The other three pits were generally smaller, but of similar rounded forms and contained variations on the same mid- to dark brownish-grey charcoal-stained sandy clay, none of them produced finds. Pit 3253, which was adjacent to pit 3258, contained a moderate concentration of burnt flint. Together, these pits give a general impression of activities that may have involved heating water.

Two curvilinear gullies lay west of the principal boundary (Fig 3). They may have been the remnants of ditches that had surrounded the roundhouses, R1 and R2, but were badly truncated.

Semi-circular gully 3057, R1, was open to the north-east; the arc was 6.5m long and 5.0m across, which would have encircled an area 8–9m in diameter. The gully was 0.6m wide by 0.23m deep and its profile had gently curving sides and a flattish base. To the south-west a more substantial semi-circular gully, 3222, would probably have encircled an area of 10–11m diameter. A shallow curved profile survived, 0.5m wide by 0.16m deep. The fill of both features produced Iron Age pottery. Six shallow pits in the vicinity of Roundhouse R1, contained dumps of burnt stone. Two of these were adjacent to the boundary ditch and two intercutting pits lay within the roundhouse perimeter, perhaps the remnants of a former hearth. None of the pits produced datable finds and it would seem that the roundhouses were occupied for a very short space of time. The presence of smaller, finer, bowls with smoothed or burnished surfaces may suggest that domestic activity was concentrated within the first century BC.

Late Iron Age water sources

Two substantial rounded pits produced pottery dating from the later Iron Age, well 3246 and pond 3251 (Fig 3). They were probably successors to the water hole 3077, but appeared to function in slightly different ways.

Pond 3251 lay at the junction of the Iron Age ditches 3204 and 3240, where the surviving depression would have been likely to pool water. The pond was the larger of the two water sources, but was far too steep-sided to allow cattle to drink without risk of plunging in (Fig 4). It was 4.9m wide and was hand excavated to a depth of 1.1m. The basal fill comprised dark greyish-brown clay silt 3265 containing infrequent white flecks and it had a clear horizon with the greyish-orange clay silt 3264 that was above it. Above this, variants of orange-grey silty clay 3263 comprised gradual accumulations of material washed in from the surrounding area that merged towards bluish-grey and yellow mottled silty clay 3250. The pond was deliberately filled at the surface with mid- to dark greyish-orange silty clay 3249.

Well 3246 lay at the southern terminal of the ditches and was 4.3m wide by 1.3m deep, somewhat smaller than pond 3251 and lay outside Enclosure E1. It had very steep edges, although one side was stepped and could have allowed water collection from the sinkhole by means of a bucket, waterskin or other receptacle (Fig 4). The upper edges of the profile were heavily eroded and extremely uneven where disturbed in antiquity. Sedimentation towards the base was fairly minimal, comprising firm grey silty clay 3245 with charcoal flecks. The overlying dump of material was grey silty clay 3244 mottled with russet iron salt streaks and a similar, slightly more yellowish-brown silty clay 3243 was dumped in the north-west side of

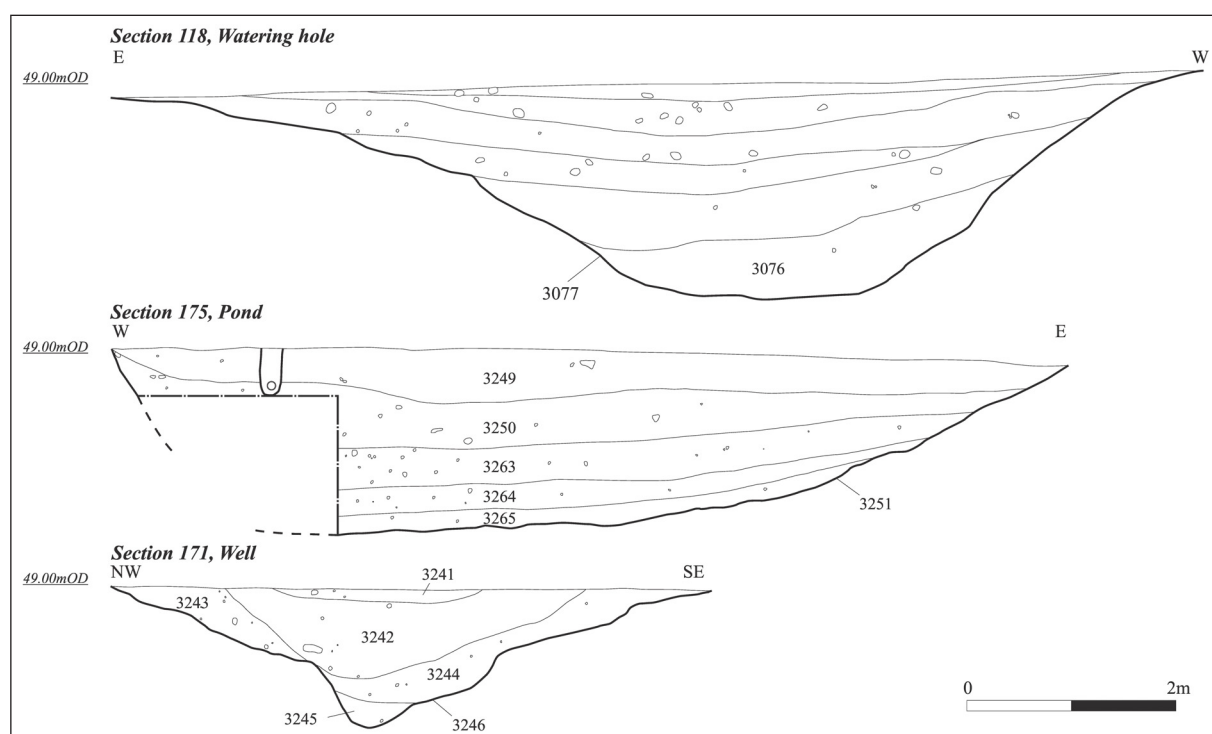

Figure 4. Iron Age water sources.



Figure 5. Iron Age jar with semi-regular latticework scoring (Scale 50mm).

the fill. Both deposits were overlain by dark greyish-brown silty clay 3242 that merged towards a slightly darker, charcoal smeared patch, at the surface.

Planorbid molluscs, identified by Karen Deighton, included freshwater taxa, indicating the feature was open longer than other pits. Terrestrial taxa are a mixture of grassland and shade loving species, commonly found in most temperate environments where cultivated land, grassland, low ground cover shrubs or hedgerows and scattered trees are found in combination. Their deposition in the upper portions of fill suggests deliberate infill. The quantity of molluscs

is moderate, indicating a healthy environment that could easily have included both good quality grazing and arable land.

Late Iron Age reorganisation

The irregular arrangement of middle Iron Age boundaries were replaced by a more regular arrangement that was probably created in the early first century AD and were in need of maintenance by the end of that century. These features extended beyond the middle Iron Age settlement (Figs 3 and 6). The ditches

retained the general orientation of site. There was an overall extension of enclosure that parcelled land into smaller units.

Initially the alignment of the Iron Age principal boundary was respected by ditch 3108 (Fig 6). This was shallow with an eroded U-shaped profile and was 1.6m wide by 0.4m deep. The silty grey fill was indicative of gradual sedimentary wash accumulated from the sides. The ditch may have continued to the north, into an area obscured by extensive modern disturbances. The presence of pottery containing grog suggests it was laid out in the early decades of the first century AD.

To the north ditch 3046 was aligned east-west and may have formed part of the reorganisation. Ditch 3046 was 0.84m wide by 0.41m deep; it had fairly steep sides that sloped sharply towards a flattish base. In parts the ditch showed signs of water erosion, creating more curved sides. Its fill was characterised by sedimentary wash.

Another ditch, 3126, extended westward from ditch 3108. This was 0.44m wide by 0.22m deep with a rounded U-shaped profile and is likely to have been contemporary with ditch 3108.

Discussion

The radiocarbon date was useful in support of artefactual assemblage studies. There was a broad correlation between the date of the initial sedimentation of the watering hole and the first middle Iron Age pottery in its fill, which placed this event at the end of third century BC and the beginning of the second century BC. Occupation was therefore from the middle Iron Age and into the Roman period, with no evidence for early Iron Age occupation.

It was generally clear from the study of stratigraphic relationships and artefact deposition that initial development focused around a possible watering hole. In an unenclosed landscape this feature was the first evidence of human management practice and may have served livestock grazing upland pasture. The watering hole probably existed as the sole landscape feature for a period of time, as little pottery occurred in its basal sediments until it had accumulated a fair proportion of other non-domestic materials such as hill wash, dead wood and leaf litter.

The watering hole was subsequently developed with an axial boundary ditch as pottery and animal bone deposition gradually began to increase. The ditch probably served a dual purpose; it channelled water and divided the land. This increased investment in the management of previously unenclosed land remained more or less consistent for a period of time, with the boundary occasionally receiving maintenance. Artefacts accumulated through casual losses and discards, rather than by dumping. Such activity lay slightly further from domestic areas and was the state of affairs for the larger part of the second century BC.

The situation changed by the first century BC and

it is possible that at least two roundhouses (R1 and R2) stood to the west of the boundary and an enclosure (E1) lay to the east of the boundary, perhaps for animals. Animal bone as a whole remained infrequent at a time when its accretion might be expected to be most prominent, suggesting that preservation conditions probably distort their contribution to the study. The axial ditch may simply have marked a divide between farmland and the area of human habitation, but it is uncertain how soon the domestic occupation took place due to modern truncation.

Pottery was the principal domestic artefactual component of the site. Thirty-nine out of sixty contexts producing pottery contained less than ten sherds, and only eight contained more than 100g. The larger groups include two sections through watering hole 3077, producing 417g and 269g respectively. The major group is the assemblage of 2134g from ditch 3204. This group contains larger sherds that are evidently from a small number of vessels, with the 141 sherds forming nine sherd families. The small groups contain little diagnostic material but the presence of scored ware and the dearth of other forms of decoration define the overall balance of the assemblage as middle Iron Age in character.

Pottery containing grog forms 5.6% of the assemblage by weight and these were present in only seven of 60 contexts that contained Iron Age pottery. Three of these, ditches 3108, 3126 and 3145, are closely associated with enclosure E2. Pond 3251 and well 3246 also contained grog ware. The distribution and associations indicate that the pottery containing grog dates to the final phase of Iron Age activity, probably the early first century AD. This suggests that the reorganisation of the site took place in the early decades of the first century AD and was retained in that form until its abandonment.

Enclosure E1 appeared to have been created to care for valuable livestock in close proximity to the settlement, perhaps milking cows, goats or sheep. There were no pig bones, perhaps an indicator of generally low affluence or a largely cleared landscape lacking in mast and unsuitable for pannage which is generally associated with woodland. A quern fragment in coarse sandstone was recovered. The only cereal grains from the site were recovered from ditch 3204 they included a small quantity of wild/weed seeds and some possible spelt wheat, there was no chaff and the seeds do not represent a primary dump or processing waste. A subsistence-based household economy, perhaps for a single family unit, seems to have been present within a short space of time. Roundhouses R1 and R2 may represent gradual migration of settlement towards the boundary from the west. In this instance a good place to look for earlier structures might be to the west of Crow Spinney Lane (Fig 1). However, it is very probable that given the general scarcity of remains, there may be no wider settlement at all.

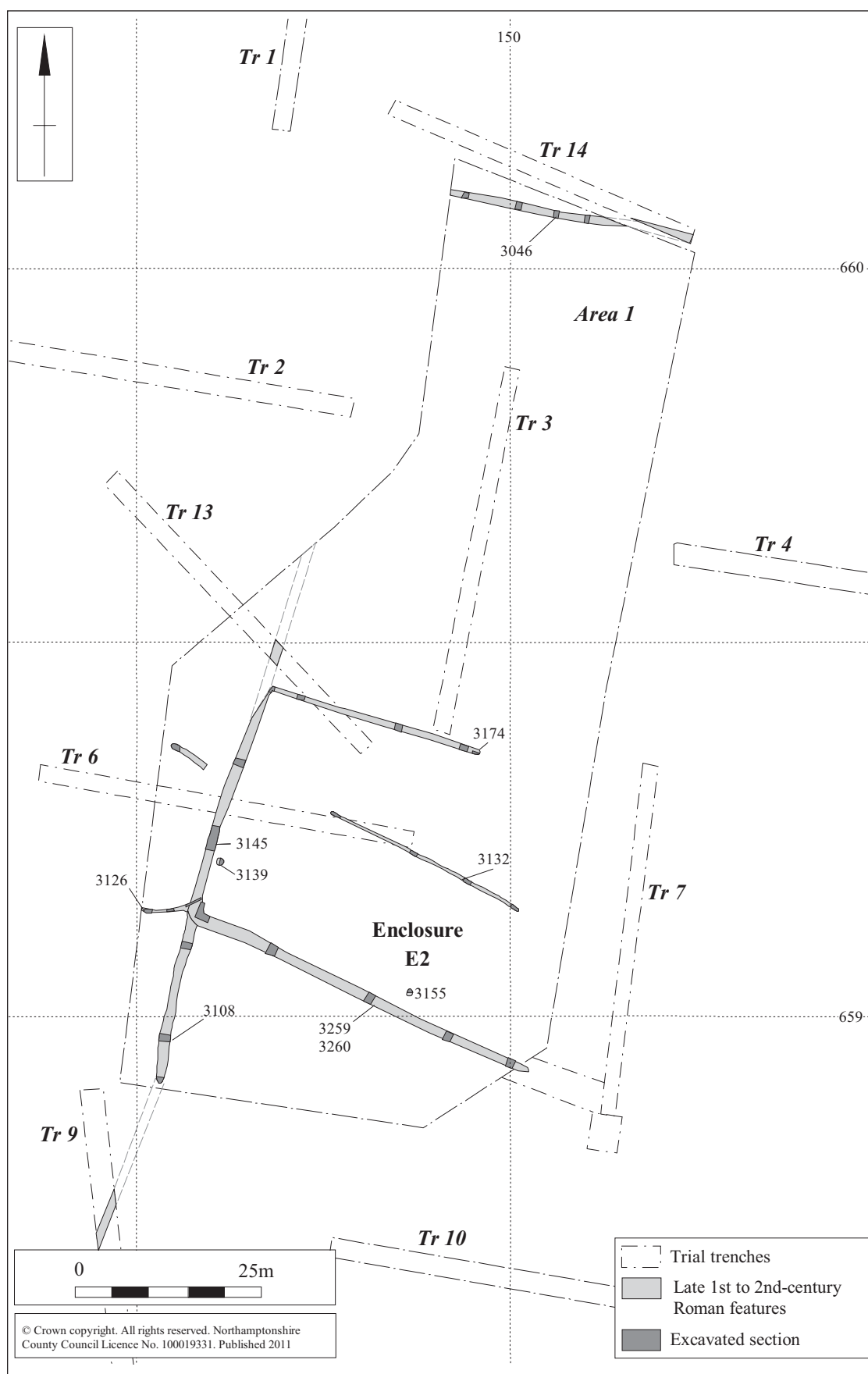

Figure 6. Late Iron Age to early Roman features, Area 1.

Late first to second century Roman occupation

Changes to the arrangement of land boundaries enacted in the early first century AD were the basis for the Roman enclosures. A wider distribution of boundaries was established, within which were smaller utilitarian enclosures, possibly with structures (Figs 6–8, E2–E3). Evidence for Roman domestic occupation immediately nearby was generally poor but did not exclude the possibility of some less substantial buildings. Whilst cattle bone continued to be present alongside goat or sheep, its incidence was significantly lower and noticeable mainly in areas expected to disturb Iron Age contexts in enclosure E2, indicating the probable residual nature. However, one sixth of the animal bone assemblage by count comprised horse bones, almost entirely from enclosure E2. Dog bones were noted for the first time and pigs were absent. Enclosure E3 by contrast produced no animal bone, cattle or otherwise. A quern, examined by Andy Chapman, indicated processing of cereals. This upper grinding stone fragment, recovered from ditch 2065, is 23–37mm thick and from a stone in millstone grit that would have been 450–500mm in diameter. The thinness of the stone, the minimal curvature of the grinding surface and the dimpled tool marks upon it, are all characteristic of Roman flat rotary querns. However, there was a lack of primary cereal processing waste, either a result of preservation conditions or because such activities did not take place at this location. Scattered Roman pottery, examined by Tora Hylton, comprised mainly utilitarian jars and bowls in mundane fabrics and there were no primary domestic waste dumps or ceramic building materials and only one metal find, an iron nail from enclosure E3.

There are 146 sherds of Roman pottery with a combined weight of 1.29kg from 30 contexts. The distribution was roughly equal between the excavated areas. The condition of the pottery is good, fragmentary, with few diagnostic sherds. The overall average sherd weight is 8.3g. Some of the sherds display signs of abrasion. The assemblage is dominated by locally-produced coarse wares in greyware (52% by weight) and shell-gritted fabrics (33%), together with a small group of undiagnostic sand-tempered wares (12%). The range of forms suggests a late first to mid-second century date. A single sherd of Lower Nene Valley colour-coated ware extends the date range to c. AD250.

Greyware forms, some originating from the Lower Nene Valley industry, comprise necked and neckless jars, a shallow bowl/dish (Howe *et al.* 1980, fig 2, 18) and a wide mouthed bowl. Shell-gritted wares are represented by a jar with lid-seating (channel rim), necked jars and a storage jar. A single sherd of Samian ware, from a drag 36 dish, dates to the late second century (Webster 1996, 46).

Palisade enclosure E2

An almost uniform rectangular enclosure (E2) was attached to the eastern side of ditch 3108, in the same way that the earlier enclosure (E1) had been added to

its antecedent (Fig 6). The palisade area was 40m by 35m, an area of c. 0.14ha. Domestic waste was sparse and the open eastern side is probably the result of truncation given their varied depths.

The boundary ditches or slots were narrow, no more than 0.5m wide, with near vertical sides and flat bases (Fig 7). The south side, slot 3259, was 0.5m deeper than its north counterpart, slot 3174, which was only 0.3m deep. Slot 3145, cut through ditch 3108 on the west side of enclosure E2, and exhibited the same characteristics. It was 1.0m wide by 0.84m deep with sharp near vertical sides and a broad flat base. The profiles were atypical of enclosure drainage ditches and were more characteristic of a slot to hold a timber palisade. The south and west sides of enclosure E2 indicated later disturbance to the upper profile of the sides, increasing the apparent width at the top, perhaps a by-product of removing the palisade timbers and filled in thereafter. The cut was near vertical, up to 0.75 wide by 0.50m deep along the south side and up to 1.05m wide by 0.90m deep along the west side.

A narrow gully, 3132, formed a central partition along the length of the enclosure. It was no more than 0.44m wide by 0.25m deep, rounded with a flattish base. The fill was mid-bluish-orange and grey speckled silty clay and its function was not clear. If associated with a structure, then nothing else survived. Its position marked a partition of enclosure E2.

Two small circular pits, 3139 and 3155, lay within the enclosure. Both pits lay close to the palisade but were distant from one another. Pit 3139 was 0.46m wide by 0.18m deep and pit 3155 was 0.6m wide by 0.4m deep. Both contained darkish grey silty clay stained with charcoal.

Enclosure E3

Enclosure E3 lay to the south (Fig 8). It comprised two small paddocks separated by an internal partition, positioned at the north-east corner of an enclosure that extended beyond the excavated area. This sub-enclosure was bounded by a double ditch on the north and east sides. Enclosure E3 was c. 16m long by c. 14m wide and encompassed an area of 0.02ha with an entrance in the centre of the north-west side. Finds from the enclosure indicated abandonment by the mid-second century.

The outer ditch, 2034, was 0.95m wide by 0.45m deep. It had distinctive steep sloping sides that met towards a V-shaped base with a slight rounded curvature of the sides indicative of erosion. It was filled with light to dark greyish-brown silty clay with black and orangey-yellow mottled variations produced through sedimentation with occasional episodes of silt wash. The inner ditch formed the north and east sides of enclosure E3, ditch 2065. The two ditches were c. 6m apart; the ground between them contained no other substantial features. Ditch 2065 was 0.5–0.6m wide by 0.25–0.30m deep, and was similar to ditch 2034. The fill demonstrated a clear difference between silting at the base and deliberate infill towards the surface.

The ditches that defined the perimeter of enclosure

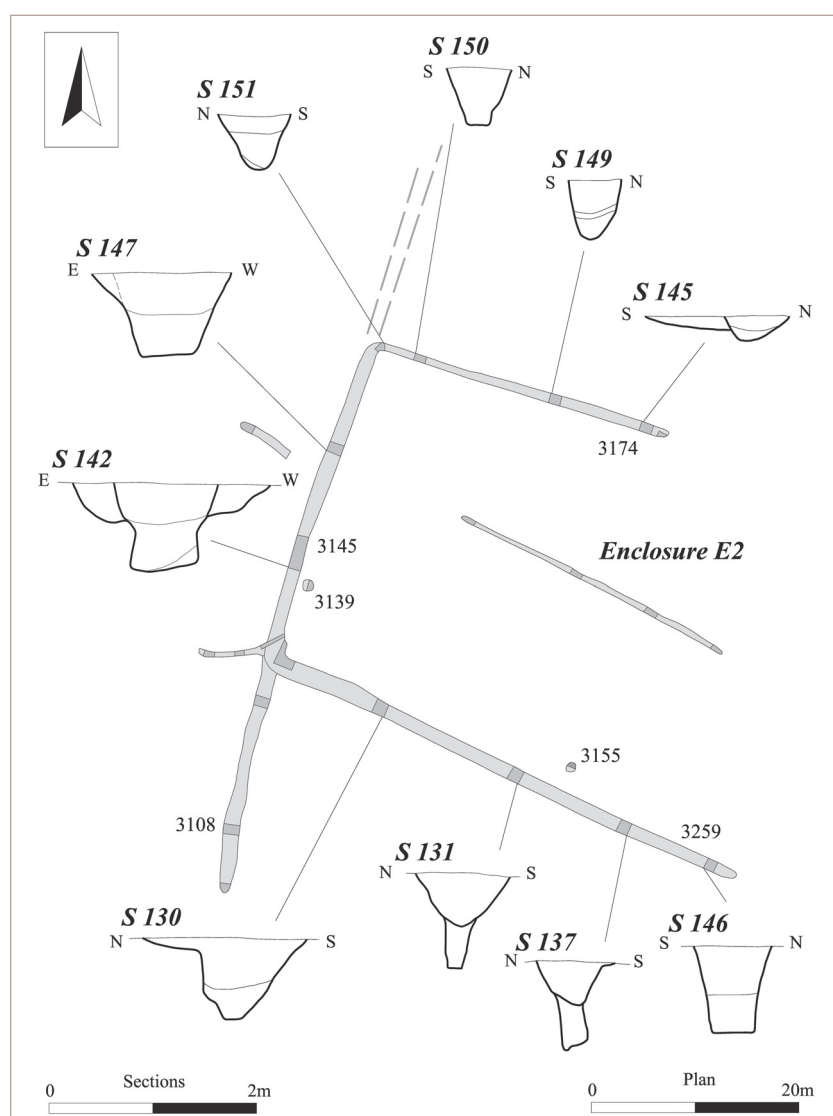

Figure 7. Palisade sections, Enclosure E2.

E3 were 2014 and 2046, to either side of the entrance, and ditch 2065 around its north and east sides. The entrance was 3.5m wide. The surrounding ditches were generally 0.60–0.86m wide by 0.25–0.38m deep, steeply angled curving sides met in narrow rounded bases. Fill material was mainly light greyish- and orangey-brown sandy clay, speckled with moderate chalky flecks.

The enclosure was divided into front (west) and rear (east) segments relative to the position of the entrance. Ditch 2077, 0.5m wide by 0.3m deep, created this partition with a terminal end was towards the south, leaving a crossing between the two segments. Sharp sloping sides met in a V-shaped base. Three fragments of white mortar from this ditch, examined by Pat Chapman, are the only Roman building materials from the site.

A line of four postholes lay parallel to ditch 2077. The postholes were unevenly spaced at 2.0m, 3.5m and 7.5m intervals. They were consistently circular,

less than 0.5m in diameter and up to 0.28m deep, which would have housed substantial timber posts. A few packing stones were evident. A single posthole 2070 was present in the north-eastern angle of the enclosure that was 0.18m wide by 0.10m deep.

Features outside enclosure E3

Pit 2049 lay within the entrance; it was rounded, 0.9m wide by 0.30m deep and filled with firm orangey-brown silty clay. The pit contained a single sherd of Roman shell-gritted pottery and an iron nail, identified by Tora Hylton, with a T-shaped head, representing a Manning type 3 (1985, fig 32). Pit 2028 lay further to the south, outside the enclosure and away from the entrance. It was 0.40m wide by 0.13m deep with gently curving sides and a rounded base, containing dark grey charcoal stained silty clay and another sherd of shell-gritted pottery.

A further group of seven pits or postholes (P1) were

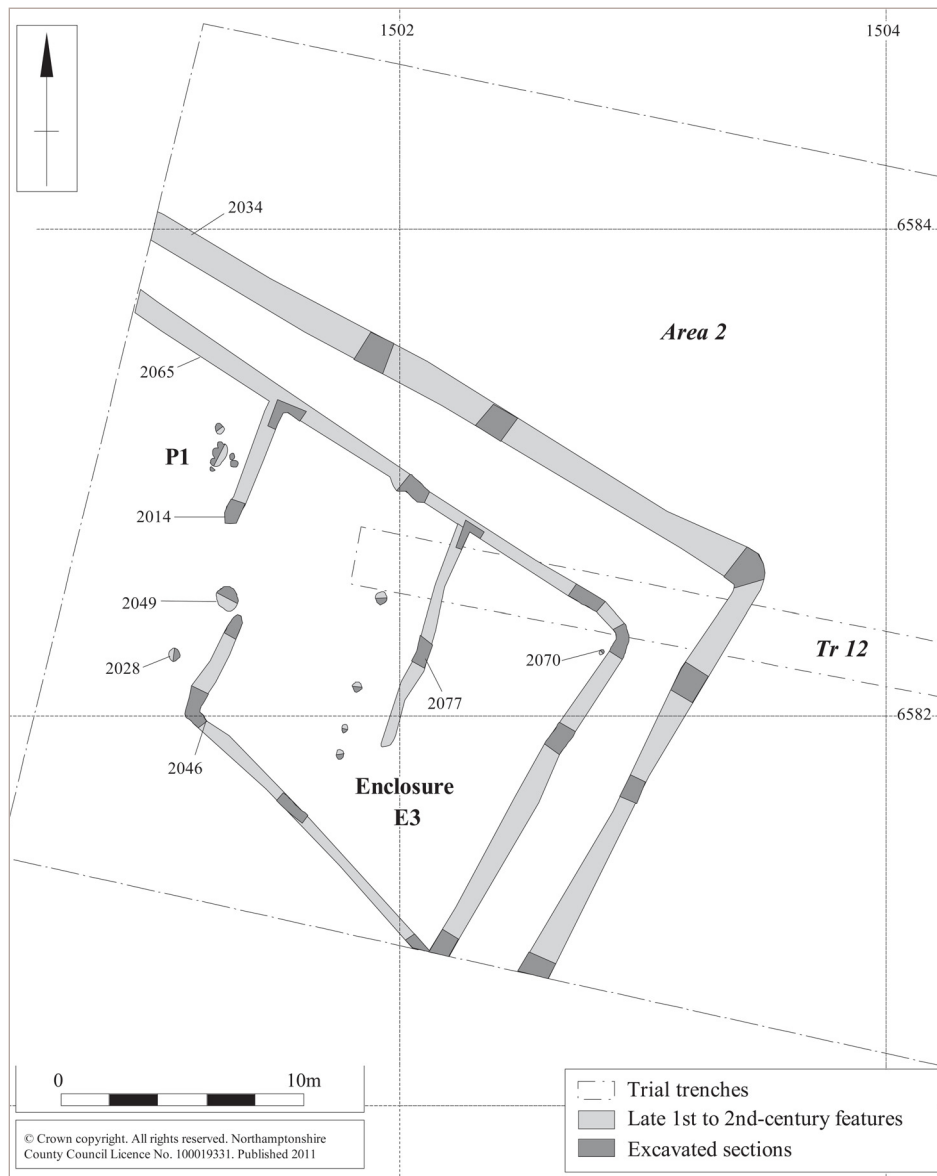

Figure 8. Late Iron Age to early Roman features, Area 2.

clustered together on the north side of the entrance. The features were all generally rounded, but they had no distinctive distribution to suggest a structure. The largest was 0.65m wide by 0.30m deep, but most were c. 0.22m wide by 0.20m deep. In general they had fairly sharp, sometimes steep, sloping sides and rounded bowl-like bases more like postholes than pits. None of them contained finds.

Discussion

The palisade (E2) was constructed subsequent to the wider ditch system being reorganised, probably within a fairly short space of time, as it seemed to be the successor of enclosure E1. A palisade was inferred by the shape and dimensions of the slots that

remained (Fig 7). The sharp, narrow, profiles were similar to the steep profiles observed in a continuous trench along one side of a large ditch at Manor Farm, Silchester (Fulford 1984, 40). The principal difference was their context; the palisade at Silchester was probably part of the defences, whilst the example at Littlehey appeared to be non-military. Pottery obtained from the fills indicated that the palisade was probably removed in the late second century. A palisade is an unusual feature on a rural site and would tend to suggest a great measure of value attached to its function. There was, unfortunately, a general lack of evidence to expand upon this. Less substantial features, such as sill beam buildings, may have been lost to modern truncation, like the south-east side of the palisade slots, and no postholes survived. The association with horse bones may be significant, but the

loss of the well and the larger pond before the late first century AD, suggested that any animals were not kept here permanently or that other water sources were available outside of the excavated area. The period of use bridged the first to second centuries AD and may have continued until the late second century AD when all of the Roman features were filled in or had been abandoned.

Enclosure E3 was clearly part of a wider Roman ditch system and much of its pottery is of the mid-to late second century AD into the early third century AD, perhaps surviving slightly later than the palisade. It produced the single example of Lower Nene Valley colour-coated ware providing the likely date of abandonment before the mid-third century. A complete absence of other artefacts or environmental data, including animal bone, made this enclosure extremely difficult to interpret, although it probably contained a small post-built structure, there is no evidence for its specific function. A double ditch around its north-east side was spaced at c. 6m width, which perhaps bounded it within the corner of a larger enclosure and flanked a bank or hedgerow. Attempts to identify its continuation beyond Area 2 were unsuccessful.

Roman disuse

The frequency of late second and early third-century pottery dropped significantly. A single piece of Lower Nene Valley colour-coated ware from ditch 2065 tends to support an early abandonment before the mid-third century. This particular Roman fabric was prevalent in the Cambridgeshire region, replacing other finewares as the favoured pottery type (Jackson and Potter 1996, 474–475). A near absence of the fabric suggested that the enclosures were probably abandoned by the third century and Roman domestic activity ceased. Finewares were generally used for domestic purposes such as tableware, drinking vessels and decorative ceramics, its near absence also indicates a low level of affluence in which more mundane utilitarian pottery types such as coarsewares and greywares are typical.

Late land use

There was no further activity evident until the modern period. This tends to suggest an end to agricultural land use, although low intensity grazing may have continued leaving no discernable archaeological trace (Liddle 1994). The area of West Perry was a significant late Saxon settlement recorded in the Domesday Survey of 1086 (Harvey 1975). The absence of medieval cultivation suggests that severe truncation may be a root cause. Extensive modern disturbance was dated to the construction of the modern prison sports field in 1988. The impact of truncation was a major inhibition towards retrieving a complete plan.

Conclusion

Occupation of the site from the middle Iron Age appeared to have been fairly limited and there was a generally low level of material such as domestic waste within the more substantial features. A total of 6.56kg of pottery, most of which is heavily fragmented, was low for the size of the area and the number of sections excavated, regardless of the vagaries of archaeological sampling. Only one prehistoric site was previously known locally, a flint scatter, and there were no recorded instances of Iron Age enclosures within 1km. It is hard therefore to be certain if the low intensity occupation evidence is the result of truncation or the result of a marginal location.

The occurrence of fabrics containing grog amongst the pottery suggested that the characteristically native Iron Age roundhouse occupation, with associated non-uniform enclosure (E1), irregular meandering ditch lines and scattered features, continued until the early first century AD. As the boundary accumulated sediment it would also have become colonised by small shrubs and may have become a broken hedgerow. Typical of many native settlements around this time, the arrangement of its features were radically reorganised. Cropmark and fieldwalking evidence from Iron Age and Roman sites at Raunds Road (Parry 2006, 243–4), Red House (*ibid*, 251–4), Napleton Lodge (*ibid*, 254), New England Farm (*ibid*, 255–6), Keyston Road (*ibid*, 258–261) and Laundes (*ibid*, 266–8), all in Northamptonshire, compare favourably but have not been tested by excavation. The reorganisation of features excavated at Broadway Fields, Yaxley, Cambridgeshire (Brown 2008, 53–55) demonstrated that fundamental elements such as the axial boundary were retained, but the overall reorganisation was planned in a uniform arrangement to enclose the landscape. Similarities have been observed at other Iron Age to Roman transitional sites.

Formalisation of the landscape over large areas is generally a good indication for a greater level of organisation. In this case it may represent adaptation to changing social and economic trends from the first century AD. Indicators of domestic occupation in terms of structures or artefacts were extremely few for this period onwards. Most evidence was attuned towards enclosure based activities, perhaps cultivation. Pottery quantities, forms and fragmentation were low and did not include early finewares. There were no ceramic building materials, fixtures, fittings, general ironwork, personal artefacts, coins or other items that are usually associated with substantial domestic buildings. Less substantial buildings may have been present, the remains of which did not survive, if this was the case they were probably short-lived structures. A single hand rotary quern fragment attested to food preparation. The instances of animal bone deposition remained at a consistent level, cattle and sheep were still present, but the instances of horse bones were significantly greater and generally associated with the palisade enclosure (E2).

The site as a whole appears somewhat marginal.

The reorganisation of boundaries and enclosures for agriculture was extensive and indicated a substantial investiture of time and effort. The scale of this endeavour over a wider area is not known, so it is not certain whether there was a small scale farmstead nearby or if these enclosures were a fragment of a larger villa enterprise. It is also problematic to determine whether the late Iron Age and early Roman development of the site remained at a subsistence level, or whether it had grown to meet a market economy. Despite being c. 10km south-west of the Roman town of *Durovigutum* (Godmanchester), its early demise indicates a low value site. Several Roman sites have been studied over an area of four parishes around Raunds, Northamptonshire, within 12–15km to the north-west of HMP Littlehey and south of the Roman town at Ashton (Parry 2006, 76–81). These studies indicate that there was disparity in the periods of disuse and abandonment between rural settlements within the same area. Most early Roman enclosures followed Iron Age antecedents. However, in the later Roman period there was a sharp decline in settlement activity amongst sites upon the boulder clay plateau. The trend was accompanied by increased activity at Laundes, Hargrave, to the north-west (Parry 2006, 273). It seemed to gain its momentum at the expense of surrounding, perhaps less successful or desirable sites, giving an overall pattern of late Roman nucleation. This trend may explain the early abandonment at Littlehey, which is typical of some of the upland sites in the region. At Medbourne, Leicestershire, the lack of pottery deposited in manure scatters indicated the end of upland cultivation in the late Roman period was accompanied by a change in land use to woodland and pasture, reducing deposition to small casual losses representative of shepherding activity (Liddle 1994, 35). A similar situation may have occurred here.

Acknowledgements

The excavation was funded by CgMs Consulting Ltd with Paul Gajos as consultant. The project was managed by Adam Yates, supervised by Leon Field. Work was undertaken by Jim Burke, Nathan Flavell, Rob Smith, Daniel Nagy and Peter Haynes. An Updated Project Design was compiled by Adam Yates and Leon Field, approved by Andy Thomas of Cambridgeshire Archaeological Planning and Countryside Advice (CAPCA). The final report text was prepared by Jim Brown, who reorganised and edited the text for publication, with final reading by Andy Chapman. Illustrations are by Amir Bassir and Charlotte Walker.

The specialist reports, which are available in the full archive and within the digital copy of the report deposited with the Archaeology Data Service (ADS), were produced by the following people: worked flint, Yvonne Wolfram-Murray; prehistoric pottery and querns, Andy Chapman; Roman pottery and metalwork, Tora Hylton; fired clay and mortar, Pat Chapman; animal bone and seeds, Karen Deighton; charcoal and wood, Dana Challinor.

The project archive has been donated to Cambridge County Archaeology Office.

Bibliography

- British Geological Survey 2001 *Solid geology map, UK south sheet, scale 1:625 000*. British Geological Survey.
- Brown, J, 2008 *Late Iron age occupation and the emergence of a Roman farming settlement at Broadway Fields, Yaxley, Huntingdonshire*. Northamptonshire Archaeology report, 08/135.
- Field, L, and Yates, A, 2009 *Assessment report and updated project design for archaeological works at HMP Littlehey, West Perry, Cambridgeshire*. Northamptonshire Archaeology report, 09/128.
- Fulford, M, 1984 *Silchester: Excavations on the Defences 1974–1980*. Britannia monograph 5. Gloucester: Soc for Promotion of Roman Studies/Sutton.
- Gajos, P, 2008 *Archaeological Desk-based Assessment, HMP Littlehey, West Perry, Cambridgeshire*. CgMs Consulting, 10322/08/01.
- Gajos, P, 2009 *Specification for archaeological excavation, HMP Littlehey, West Perry, Cambridgeshire*. CgMs Consulting, 10322/09/02.
- Harvey, S, 1975 *Domesday Book 19, Huntingdonshire*. Chichester: Phillimore.
- Howe, MD, Perrin, JR, and Mackreth, DF, 1980 *Roman pottery from the Nene Valley: a guide*. Peterborough: Peterborough City Museum and Art Gallery, Occasional paper, 2.
- Jackson, R, and Potter, TW, 1996 *Excavations at Stonea, Cambridgeshire, 1980–1985*. London: British Museum Press.
- Lawes Agricultural Trust 1983 *Soils of Southern England and Wales, 4, scale 1:250 000*. Harpenden: Lawes Agricultural Trust.
- Liddle, P, 1994 The Medbourne Area Survey, in M Parker Pearson and RT Schadla-Hall (ed.) 1994 *Looking at the land: Archaeological landscapes in Eastern England, Recent work and future directions*. Leicester: Leicestershire Museums, Arts and Records Service.
- Manning, WH, 1985 *Catalogue of the Romano-British iron tools, fittings and weapons in the British Museum*. London: British Museum Publications Ltd.
- Northamptonshire Archaeology 2009 *Watching brief, trial excavations and mitigation works at HMP Littlehey, West Perry, Cambridgeshire*. ECB3112, Northamptonshire Archaeology archive.
- Parry, S, 2006 *Raunds Area Survey: an archaeological study of the landscape of Raunds, Northamptonshire, 1985–94*. Oxford: Oxbow.
- Pevsner, N, 1968 *The Buildings of England: Bedfordshire, Huntingdon and Peterborough*. London: Penguin.
- Smith, W, 2002 *A review of archaeological wood analyses in Southern England*. Centre for Archaeology report. Portsmouth: English Heritage.
- Thomas, A, 2008 *Brief for archaeological evaluation: Littlehey Prison, Crow Spinney Lane, West Perry*. CAPCA, Cambridgeshire County Council.
- Way, T, 1997 *A study of the impact of imparkment on the social landscape of Cambridgeshire and Huntingdonshire from c. 1080 to 1760*. Oxford: British Archaeological Report, Brit Ser, 258.
- Webster, P, 1996 *Roman Samian pottery in Britain*. York: Council for British Archaeology handbook 13.