

ART. XIII.—*Report of the Cumberland Excavation Committee, directed by F. G. SIMPSON. The Roman fort at Bewcastle.* By I. A. RICHMOND, MISS K. S. HODGSON and K. ST. JOSEPH. With special notes by JOHN CHARLTON, A. RAISTRICK and C. H. V. Sutherland.

FOREWORD.

UNTIL 1937, the Roman site at Bewcastle had been considered secure from interference. In that spring the Parish council resolved to extend a congested churchyard towards the west end of the fort, no more suitable site being available. Through the kindness of the Trustees of John Maxwell deceased, owners of the ground, and Mr. F. H. Martindale, Diocesan Surveyor, an examination of the area was made before the ground was vested in the Ecclesiastical Commissioners. As trenching progressed, it became necessary to extend the inquiry northwards towards Demesne Farm and into the bull-close; and also to examine the west rampart and the north-west gate. These additional inquiries were readily permitted by the Trustees, and by their tenant, Mr. G. W. Beaty, to whose kindly interest in our work we owed many facilities on the spot. Accommodation for our workmen was solved by their willingness to camp, and by the kindness of the rector, the Rev. N. C. Murray, who put the disused school-house, where Maughan the antiquary once taught, at our disposal for a dormitory. The warmest thanks of the Committee are offered to all those who thus aided the work.

i. INTRODUCTORY.

The Roman fort at Bewcastle, holding a garrison of nominally one thousand* men, occupies (fig. 1) the whole of an irregular hexagonal plateau, six acres in extent, large enough to contain the Castle, Demesne Farm,

* As denoted by the size of the fort and the rank of tribune accorded to the commanding officer (cf. *CIL.* vii, 974, *EE* ix 1227).

Church and rectory. The eminence is protected on all sides by its own steep scarp, on the south by the Kirk Beck, on the west by Hall Sike, and on the east by Bride Gill. Although the site dominates the little valley in

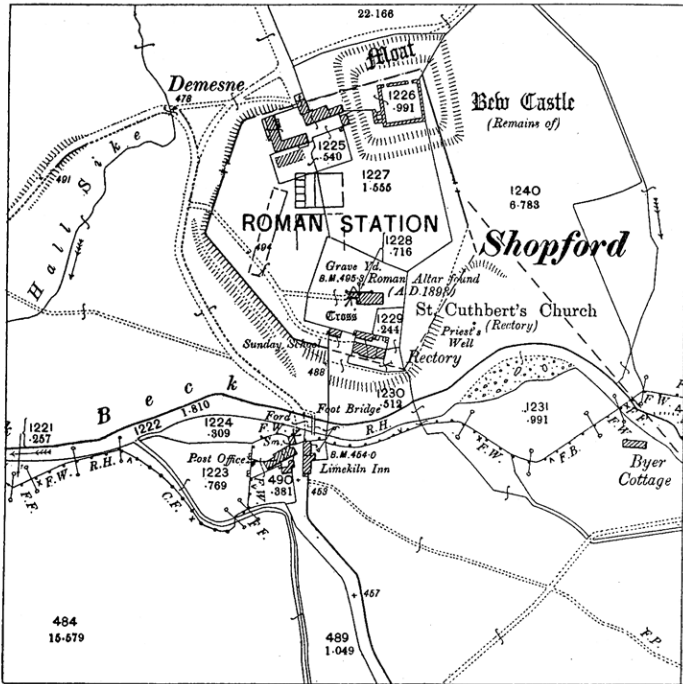

FIG. 1.—The site of Bewcastle.

Based upon the Ordnance Survey Map, with the sanction of the Controller of H.M. Stationery Office.

which it lies, it nevertheless does not command, as do most Roman forts, an extensive outlook. It is hemmed in by hills, which restrict the view in all directions except the west. Since, however, alternative sites with a wide view lie near at hand, the choice must be regarded as deliberate and explicable by other than immediate circumstances.

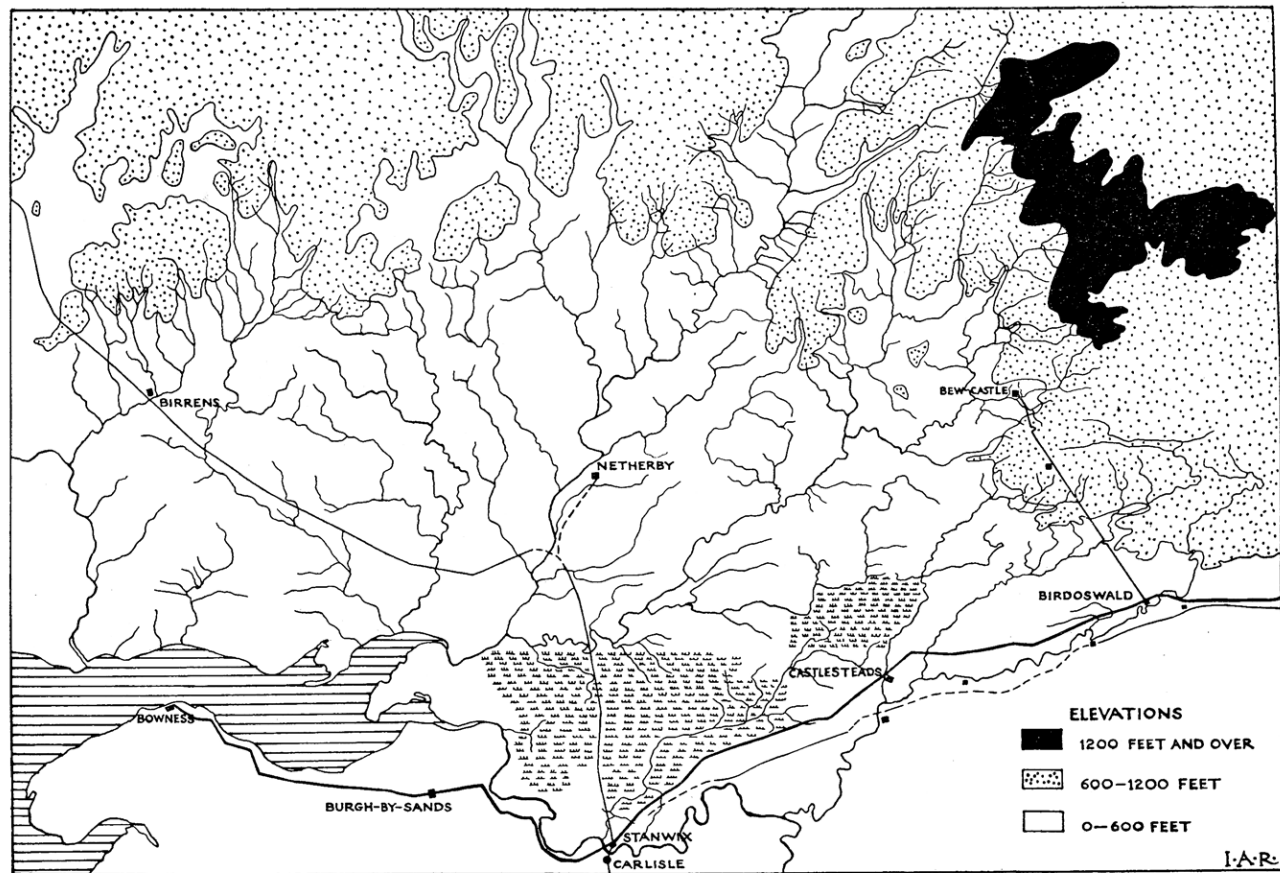

FIG. 2.—Bewcastle and the west end of Hadrian's Wall.

A lost inscription, recorded* by Horsley in 1732, suggests that the fort was designed as an outpost of Hadrian's Wall. It was connected with the Wall-fort of Birdoswald by a direct eight-mile road,† driven straight across the high shoulder of Gillalees (fig. 3), for this express purpose. Gillalees‡ is the last bold spur of the Bewcastle Fells, and was a famous medieval beacon-post. It flanks the natural corridor between Kershope Burn and the Black and White Lynes, which is the back-door of Cumberland—a narrow route encompassed§ by high crags and once trackless mosses. If this passage is watched, the frontier is secure; but it cannot be surveyed from the security of the Cumberland plain, and for this purpose an outpost is required north of Gillalees. That is why Bewcastle was planted inconspicuously at the side of the corridor, half-hidden by enfolding hills. The invader's path was not to be barred at this stage. His numbers and course were noted, and appropriate measures were taken for ambush or defence. Such was the principal function of the fort. A notable minor part in the warning-system was|| played by the tower, now called the Butt, whence signals were transmitted, unbeknown to a northern enemy, from the south slope of Gillalees to Hadrian's Wall. Finally, elementary precaution dictated that the garrison of Bewcastle should be large enough to repulse direct attack; and its size would also fit it to complete the success of an ambush by taking invaders in the rear at a pre-arranged stage in a combat.

The ancient name of the fort is not directly known; but there are strong reasons for thinking that it was *Banna*.

* *Britannia Romana*, Cumberland xlvi, p. 192, plate 45; described, p. 270.

† See R. G. Collingwood, *CW*² xxii, 178-182, and W. G. Collingwood, *CW*² xxiv, 110-116. The latter description is here supplemented by a map (fig. 3) of the course where this approaches Bewcastle.

‡ Howard Pease, *The Lord Wardens of the Marches of England and Scotland*, p. 167.

§ See Sir Walter Scott, *Guy Mannering*, cap. xxiii.

|| *CW*² xxxiii, 241-5.

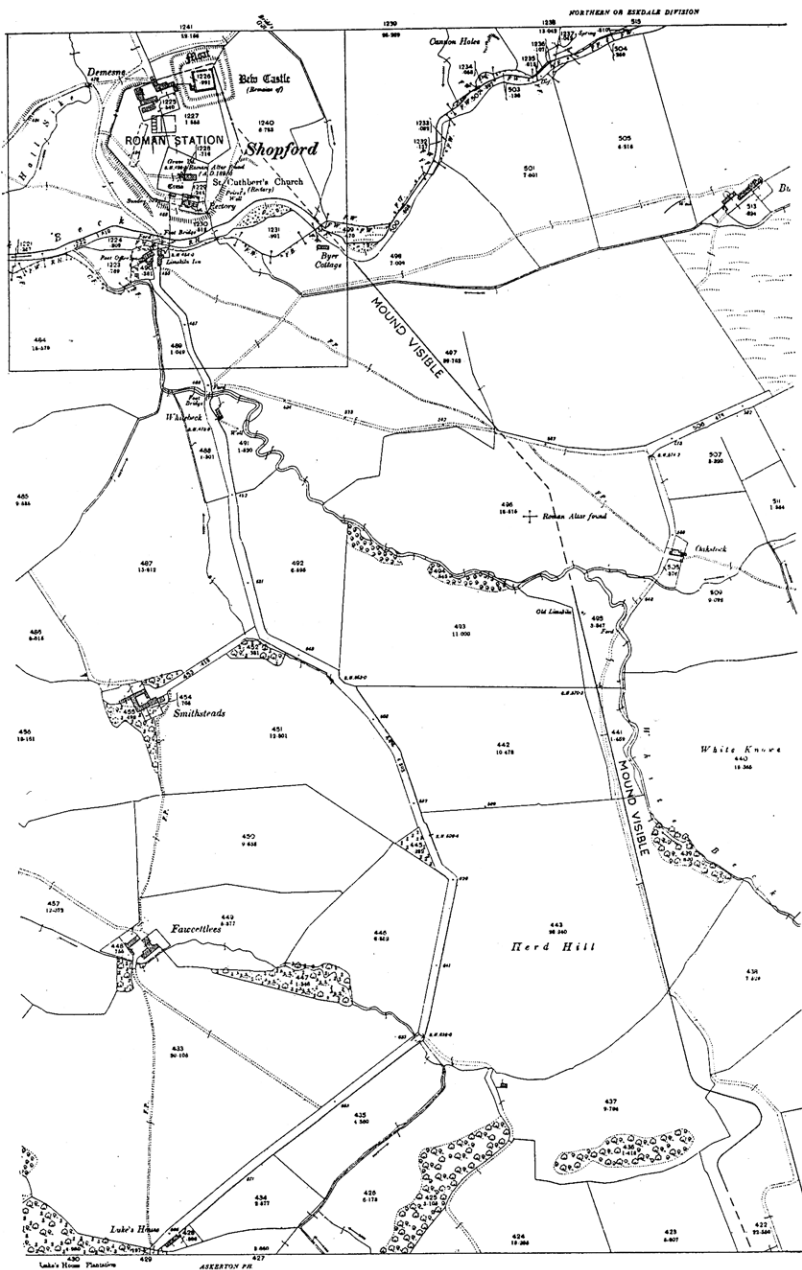

FIG. 3.—The end of the Maiden Way.

Based upon the Ordnance Survey Map, with the Sanction of the Controller of H.M. Stationery Office.

On the Rudge Cup, *Banna* follows* *Camboglanna* (Birdoswald) in a list of place-names running from west to east and connected with Hadrian's Wall. The *Notitia Dignitatum*, listing† the Wall-forts from east to west, omits *Banna*, as if it lay off the Wall yet near Birdoswald. Again, the proximity of *Banna* to Birdoswald is further attested by the altar‡ of *venatores Bannienses*, or herdsmen of *Banna*, set up in that fort. At this point, the evidence of the road-system becomes of weight. Apart from the neighbouring Wall-forts, the only place connected by a Roman road with Birdoswald is Bewcastle. Again, it lies in a region suited to herdsmen, and the herds of the Roman army often pastured§ in neutral zones beyond the main frontier-line, as in Lower Germany. Finally, the word *banna*, like its familiar cognates *ben* and *pen*, means|| a peak, spur or headland. In the Birdoswald district the single and pre-eminent hill of this type is Gillalees, below which Bewcastle lies. Transferences of name, from hills to places near them, are common enough. Typical British examples¶ are *Trimontium*, transferred from the Eildons to Newstead, *Pennocrucium*, which passed from Penkridge to the *mansio* below it, and *Banna-venta*, where *banna-* recurs and Daventry, its modern counterpart, rises on a bold ridge out of the Midland plain. *Banna* is thus seen to fit both the geographical position and physical features of Bewcastle so well as to render the equation Bewcastle=*Banna* reasonably certain.

Previous finds tell something of the history of the fort, though no site has suffered more from the disappearance of objects after their discovery. Reference has already

* *CIL.* vii, 1291: *AA*⁴ xii, 310-342.

† *Not. Dign. Occ.* xl., 32 ff.

‡ *CIL.* vii, 830; for the provenience of this altar, see CW² xxxiii, 239-40.

§ Mommsen, *Provinces of the Roman Empire* (Macmillan, 1909), ii, 214.

|| Holder, *Alt-celtischer Sprachschatz*, s.v. Benno-

¶ Trimontium, *A Roman frontier-post*, p. 21; Pennocrucium, cf. Holder, *op. cit.* s.v.

been made to the most important of these lost inscriptions, a fragment (*CIL.* vii, 978) of a large ansate building-inscription seen by Horsley* in the churchyard after its recovery from a grave. It mentioned Hadrian, the Second and Twentieth legions, and a governor whose name is lost. Grave-digging also produced the almost perfect Samian bowl by the Antonine potter Apolauster (*Trans.* xxxv, 182-205). The lost stone seen by Bainbrigg† in the church, commemorating work by the Second Legion, may also be of this earlier period. The name of the garrison remains unknown, but may have been mentioned on another lost stone, seen‡ by Hutchinson "over the channel at the gate of the public-house yard," now the yard of Demesne Farm. Two surviving altars (*CIL.* vii, 974, *EE* ix 1227) to the war-god Cocidius are, however, of later date, since the tribunes who dedicate them are promoted in the fourth-century manner from time-expired soldiers and clerks, as Mr. Eric Birley§ has observed. The exceptional devotion of the soldiers to this god is further shown by two silver plaques recorded below (p. 208) and by two lost altars,|| making six such dedications in all from this site.

A stone¶ recording a temple to Juppiter Dolichenus

* *Britannia Romana*, loc. cit.

† *CIL.* vii, 979; *Cotton Julius MS.* VI, fol. 304.

‡ The exact words of Hutchinson's *Cumberland*, p. 93, are here quoted, because their continual misquotation has led to erroneous ideas about the location of the stone. It seems to have been used as a cover-slab for the old channel which still exists in the farm-yard at this point. Maughan records that the Demesne Farm was a tavern in Hutchinson's day.

§ *CW*² xxxi, 138.

|| The original description of the first by Maughan is in the *Tullie House MS.* A316, a copy of his own *Memoir* revised by himself, to have been published in 1873; it reads, "about half a dozen years ago, by a person draining on the line of the Maiden Way, about half a mile above the station." This can only mean in a southerly direction as marked on the Ordnance Map, see fig. 3. The other is *CIL.* vii, 977; cf. Maughan, *Memoir*, p. 6, "found at Bewcastle near the place where others were found last Martinmas" (i.e. Nov., 1811), "and now, 1812, in the possession of the curate." The text of these other altars is lost.

¶ *Arch. Journ.* 1850, 129; *CIL.* vii, 976.

was last noted in 1852, in the field-wall between the north-west angle of the churchyard and Demesne Farm, but is not to be seen there now. The top of an altar* has disappeared from the rectory garden since 1922; and the unsatisfactory record may be closed by observing that a large die, now the slop-stone in the Limekiln Inn, retains no legible trace of lettering.

ii. THE EXCAVATIONS.

A start in excavating the site (fig. 4) was made by cutting a pair of trial-trenches, A and B, parallel with the west wall of the churchyard. Trench A was 140 feet long, and was later extended for another 44 feet parallel with the Demesne bull-close. It quickly revealed two late occupation-levels. The uppermost lay close below the sod and represented a repair or modification after disaster. Its walls were sometimes built directly upon the earlier foundations, but almost as often deserted their line, while its floors were separated from the lower level by a considerable layer of rubbish. The narrow trench, however, gave little information as to the planning of the latest buildings, and perhaps the most interesting feature was the remnant of a channelled hypocaust. Of the penultimate buildings, on the other hand, not a few corners were detected, as if the trench had cut across the ends of a series of narrow buildings, separated by eaves-drops and narrow streets (see fig. 4). Abundant burnt wattle-and-daub attested both the character of their superstructure and its eventual destruction by fire. The purpose of the buildings remains uncertain. In trench B, the same levels appeared, but less subdivided by walls making their interpretation still more difficult.

In the absence of significant coins, the dating of these two levels was assisted by an abundant yield of pottery. That from the penultimate level belongs to the early

* *CW*² xxii, 184, no. 7 = *EE*. iii, 114.

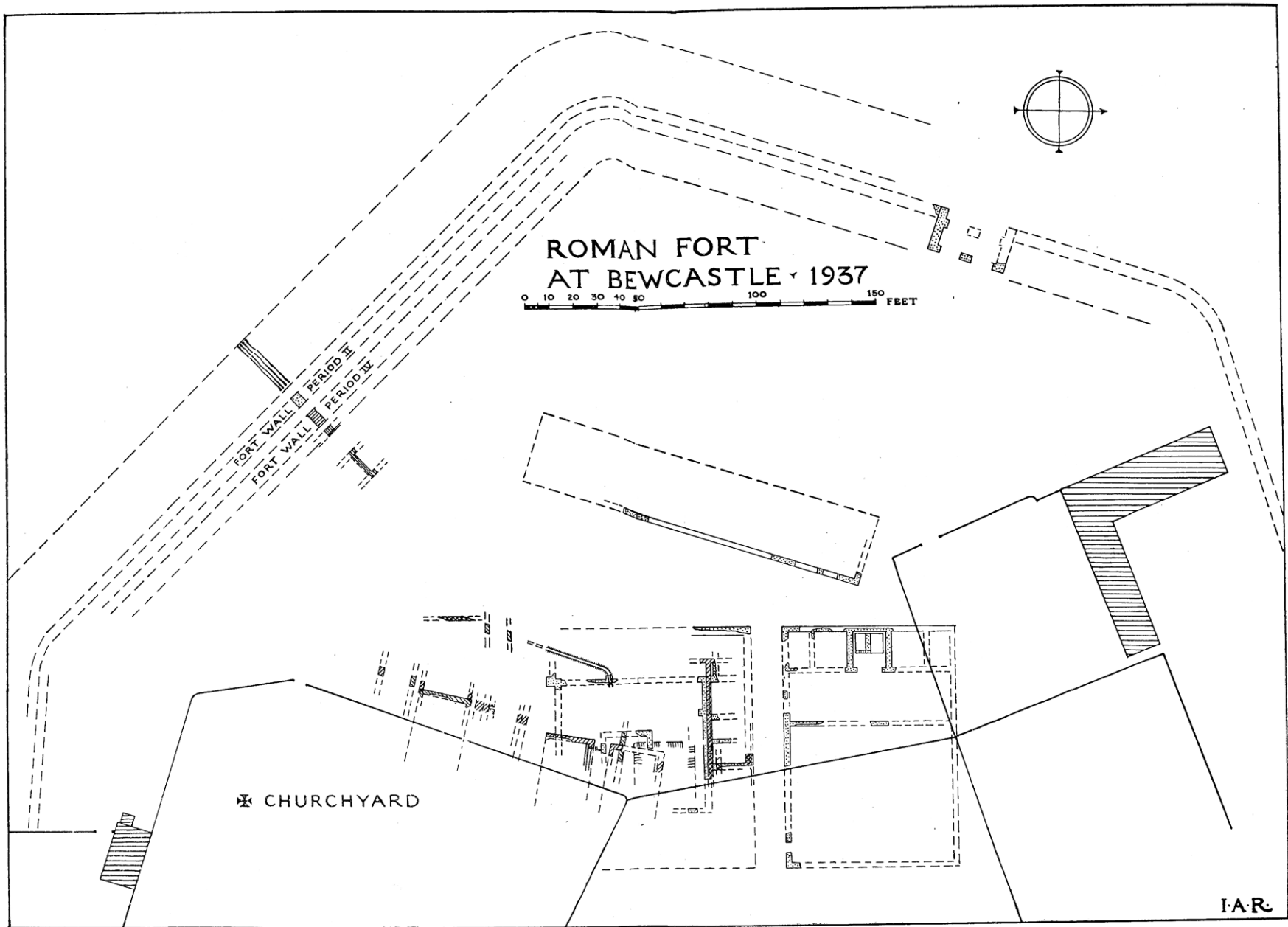

To face p. 202.

FIG. 4.

fourth century. Cooking-pots with sharply everted rims, flanged bowls and hammer-headed mortaria form a homogeneous group (figs. 25-6), matching those from the third period of occupation on Hadrian's Wall. There is, however, the very sharpest distinction between the wares of the fourth period on Hadrian's Wall and those of the final period at Bewcastle. At Bewcastle, none of the distinctive later fourth-century types, as discovered at Birdoswald* in 1929, appears; in fact, no clear distinction is to be made between the wares of the two upper levels. Both appear to fall within the period A.D. 297-367, as if one period of occupation on the Wall were matched by two in its more vulnerable outpost. There is nothing inherently unlikely in such a course of events. Indeed, although the written record of Romano-British history is notoriously meagre for this period, it does in fact twice refer to enemy activity† which concerned the frontier without affecting its main defences. In A.D. 343, a punitive expedition was conducted by the Emperor Constans in person; in A.D. 360 there was an episode in which "districts close to the frontier were wasted". Either of these records fits the evidence from Bewcastle well. Is it then possible to choose between them? Recent excavations at High Rochester and Risingham, Northumbrian outposts of the Wall corresponding to Bewcastle, have revealed‡ one fourth-century occupation at High Rochester and two at Risingham, leaving in doubt whether the final occupation at Risingham had lasted beyond A.D. 367. Evidence from all these outposts can now be

* CW² xxx, 187-198.

† Amm. Marc., xx, 1, 1; *Cod. Theod.* xi, 16, 5, mentions Constans at Boulogne on 25 January, 343, cf. Firmicus, *De error. profan. relig.*, hieme . . . tumentes ac saevientes undas calcastis oceani sub remis vestris; also, Cohen, *Méd. Imp.*, vii, Constans 9, where the Emperor is accompanied by Victory in a galley, and viii, p. 313, the famous and unique contorniate 331, with reverse legend *Bononia Oceanen(sis)* and the same theme elaborated, now in the Cabinet de France.

‡ AA⁴ xiii, 182.

compared. If their history corresponded, it would almost certainly be Constans who gave up High Rochester, retaining Bewcastle and Risingham, and count Theodosius, the reformer of A.D. 369, who withdrew* even these garrisons after convicting them of treason.

The foundation-work of the earlier fourth-century level in the southern part of trench A was unusually elaborate. The flagged floors and alleys were bedded upon rather loosely packed earth and stones, mixed with third-century pottery; while the walls rested upon a deep raft of heavy stones set in clean stiff clay, so tenacious as to prove a serious obstacle to rapid progress in excavation. When this filling was first encountered, it was hoped that it might be delimited quickly; but trench B soon revealed that the filling represented a systematic levelling of the site, covering a wide area and drained below by at least one large culvert. It is thus not explicable as, for example, the covering of an earlier ditch-system. A trial-hole at the lowest point in trench A showed it to rest upon thick burnt brushwood, covered with cut blocks of clean grey silt; while a third trench, west of B, disclosed the rim of a marsh. Again, as trenches A and B were carried northwards, they revealed the sandy subsoil rising gently out of the marsh-land towards the summit of the plateau at Demesne Farm. The south-west scarp of the plateau, on the other hand, was later (p. 215) shown to be formed by a hard ridge of coarse glacial drift, thus explaining how the marsh-producing pool could collect on top of the hill behind it. The northward extension of trenches A and B showed also that an earlier level of much better stone buildings (fig. 5) occupied the floor of the hollow, which was then presumably drained. The fourth-century builders had boldly filled the hollow up, an energetic operation which must be set against the less imposing character of their buildings. If the buildings

* *Amm. Marc.*, xxviii, 3, 8.



FIG. 5.—Foundation-work of third-century commandant's house, Bewcastle.

To face p. 204.

were less expensive, the preparation of the ground for them was a task which more ambitious builders had shirked.

The effect of these discoveries upon the excavation was to shift the exploration of the site northwards on to the higher ground, where access to the earlier buildings was not thought likely to be hampered by the deep and heavy filling. A still further extension of trenches A and B soon showed that this expectation was correct. Indeed, the recovery of earlier levels had been rendered unexpectedly easy by the activities of stone-robbers, who had removed all but the lowest courses of the late levels, leaving the earlier stratification still sealed yet easy of access. The plan of the earlier buildings could now be recovered under conditions highly favourable to rapid progress.

The new investigation commenced on the summit of the hill, south of the Demesne stack-yard. Cross-trenches rapidly disclosed a well-constructed building, associated with a road-surface dated by a *denarius* of a Severan empress (otherwise illegible) to the third century. Both the walls and deep foundations of this building were of freshly quarried stone, the foundations set in stiff blue clay, as in all the early stonework noted on the site. As excavation proceeded, the plan of the walls (see fig. 4) showed that the building was the *principia*. First emerged the front wall of the cross-hall, followed by the south side wall, the front wall of the five administrative rooms, and then their back and side walls. The north side of the building lay below the stack-yard, but its position may be calculated from the axis. The width of the *principia* is thus approximately 72 feet, while its length, 100 feet, was determined by a trench in the Demesne bull-close, which uncovered its south-east angle, together with a lateral doorway in unusual position. The whole building had, however, been so robbed that stratification, and therefore history, was only likely to be

recoverable in the *sacellum*, where an underground strong-room might be expected to contain information undisturbed by the stone-robbers. A diagonal trench across the room disclosed the presence of a built cellar, of which the history turned out to be particularly vividly preserved, as will be understood when the original arrangement has been described.

The *sacellum* was first designed (figs. 6, 7) as an open-fronted room, 14 feet wide and 15 feet 8 inches deep, with walls two feet thick, as throughout the *principia*. Below the rearward half of the room lay a cellar (fig. 8), six feet deep. This strong-room was evidently part of the original plan, though built as a separate unit, three walls being laid against those of the *sacellum*, while the fourth, two feet thick, retained the sandy subsoil below the front half of the room. The walls were carefully mortared, and proofed against damp by a rendering of fine, painted cement. The floor was similarly treated with coarser cement, in which could be seen many scraps of pottery, including a rim of Samian ware, apparently Hadrianic 37. The junction between walls and floor was covered by a rather clumsy quarter-round fillet of cement. Access to the cellar was obtained by a flight of six steps (fig. 8), also proofed with cement, which started from a narrow landing in the centre of the front, ran parallel with the front wall from north to south, and ended in the south-east corner of the cellar. Treaders were small and risers high, as commonly in Roman steps, and their edges were much worn by long use. Even while the cellar was being built, before the cement rendering was applied, a bulge developed in its front wall. When the rendering was finished, a cross-wall (fig. 9) was built, as a stay, between the stair-landing and the back of the cellar. The north half of the cellar must henceforth have been reached either by a trap-door or by a ladder from the north end of the stairs, which only cover half the threshold of the room. Both



FIG. 7.—Bewcastle, the *sacellum* in the headquarters, from the east; first stage in excavation.

To face p. 206.

tcwaas_002_1938_vol38_0015

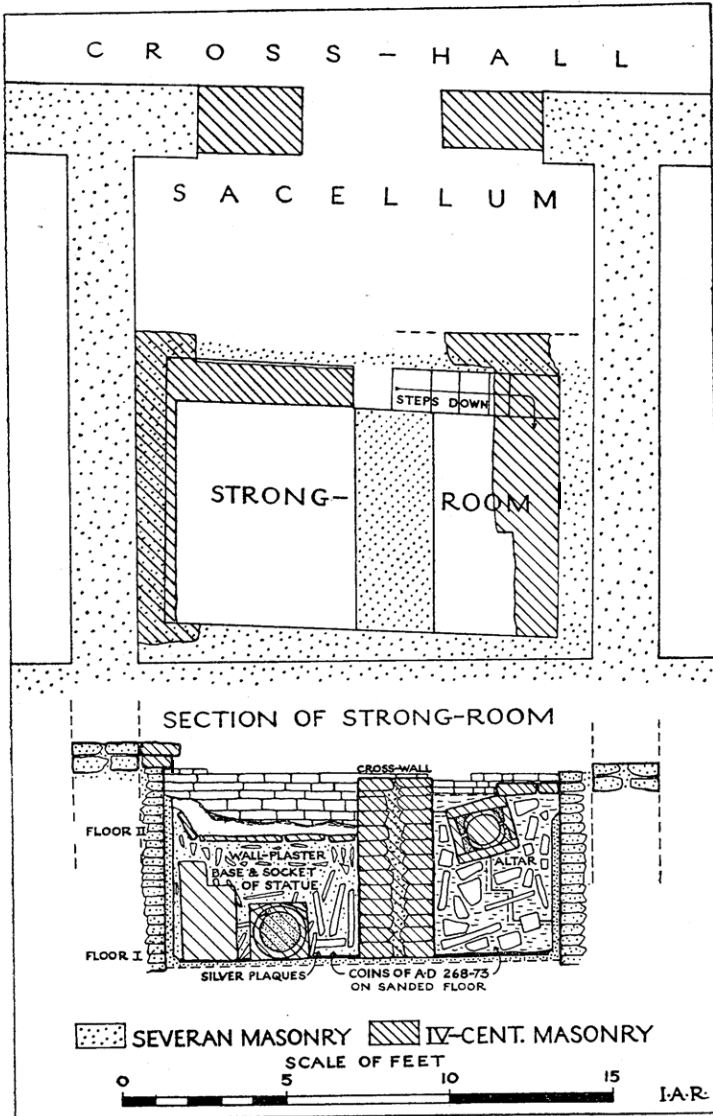

FIG. 6.

compartments were strewn with fine sand about an inch deep, as bedding for the chests or sacks which they were to contain.

After the long use denoted by heavy wear on the stairs, the cellar was involved in the wholesale destruction of the building above it, for which the evidence was remarkable and even dramatic. The lower four feet of both compartments of the cellar was choked with a mass of rubbish, fallen through the burnt floor of the shrine overhead. The most striking material was painted wall-plaster, bearing panelling of red, blue and brown. Fragments of burnt beams and thin sandstone flagging from the ceiling were mixed with it; and the flags from near the front of the cellar had fallen on end. Further observation showed that this destructive fire had followed upon looting. The contents of the cellar had evidently disappeared before the fire began, and thirteen coins, dated to A.D. 268-73, were scattered over the sanded floor. The contents of the sanctuary above the cellar had collapsed together with the floor, but in a condition which tells its own story. The stone base for a life-sized Imperial statue (fig. 12) lacked the valuable bronze which had been roughly broken out of its socket. Half of the iron thunderbolt from the sanctified Emperor's hand, parts of two bronze letters, seven iron ferrules from oak shafts for spears or flag-poles, one iron arrow-head and a broken piece of pole or shaft, sheathed in thin bronze, attested (fig. 13) a reckless smashing of the sacred appointments. Two silver plaques (fig. 14), bearing hammered representations of Cocidius, the smaller dedicated by one Av(e)ntinus, had been torn from a rich piece of votive furniture. No better proof of pillage preceding the fire could be desired; and humbler objects also speak of yet another phase in the orgy of destruction. Sherds (figs. 22, 23) representing three jars, twelve mortaria and a *dolium* had fallen among the burning rubbish. All were



FIG. 8.—Bewcastle, the *sacellum* in the headquarters, with strong-room, from the west; final stage in excavation.
tewaas 002 1938 vol38 0015
To face p. 208.



FIG. 9.—Bewcastle, strong-room in the *sacellum*, showing cross-wall.



FIG. 10.—Bewcastle, later level covering the strong-room in the *sacellum*.

broken; but, while nearly all the fragments of two jars were recognisable and could be pieced together, only a small part of most of the vessels had fallen into the cellar, showing that they had been deliberately broken and scattered before the fire took place. Why mortaria, ordinarily used for cooking, should have occurred in a sanctuary at all and should have invited wanton destruction, is shown by the fact that one of the fragments exhibits holes for suspension. They had served as hanging-lamps, containing oil for lights, as an analysis of one calcined piece showed (see p. 222). They were doubtless smashed in the first moments of wild folly before the worst desecration and pillage began. In the north-east corner of the *sacellum*, beyond the cellar, a pile of rims (fig. 22, nos. 12, 13, 14), from three different mortaria showed that some of the vessels had been sent spinning thither. A simple recital of facts and deductions reconstructs the lurid scene in sufficient detail. Nor is the date of the event difficult to fix. The coins, some considerably worn, place it well after A.D. 273 (see p. 234), while the latest pottery comes as near the fourth century in type as possible. It is therefore natural to class the destruction with the general disaster to the frontier which Constantius I repaired soon after A.D. 297 and which Bewcastle cannot have escaped.

If stone-robbers had thus spared much dramatic evidence concerning the first *principia*, they had severely handled the succeeding levels. A reconstruction is marked, however, by alterations at the entrance of the *sacellum*. A new threshold (see fig. 7) was made by laying upside down an old socketted base, and the original 10½-foot entrance was constricted to 4 feet 4 inches by narrow rough walls, perhaps foundations for stone screens. In the shrine the cellar, as already noted, was left filled with rubbish to a depth of four feet. The north compartment continued to serve as a shallow pit (fig. 10), receiving a

new front wall, two feet deep, and a flagged floor at the same depth, later somewhat disturbed. The history of the south compartment is less simple. The rubbish of the third-century destruction had been left untouched at the same level as in the north division. Then came a filling of stones and stiff yellow clay, supporting a new and wide stone scarcement. This filling included a discarded altar (fig. 15) damaged by fire, tersely dedicated (fig. 11) to the Imperial Discipline in good third-century lettering. The suggestion so far conveyed would be that a third-century altar, burnt in the disaster already described, had been used as waste material during subsequent alterations. The actual story is more complicated. After the stone was burnt, but before it was used in the filling, its back, dexter side and top had been heavily worn by feet, as if in a corner-step. This secondary use of the altar must place the filling of the south compartment in a third phase, and thus leaves the secondary treatment uncertain. Stones which look like the base of steps in front of the filled compartment appear to be of one build with the wide scarcement and also of the third phase.

Abundant evidence has now been cited to show that the stone *principia* belongs to the third century, and was in use for a long period. Again, its erection seems to coincide with the first use of stone on the site: for its foundations are not only laid in undisturbed sandy subsoil, but are built of freshly quarried stone. The contrast with most other sites in the north of England, where third-century buildings regularly overlie thickly-spread earlier levels and are built with re-used materials, calls for special note. There is also abundant evidence for a wide extension over the site of these well-built and apparently primary stone buildings. South of the *principia*, across the third-century street, trenching disclosed an equally large building, of which the north wing, apparently divided into at least four rooms, was



FIG. 11.—Altar used in filling of strong-room in the *sacellum*, Bewcastle.

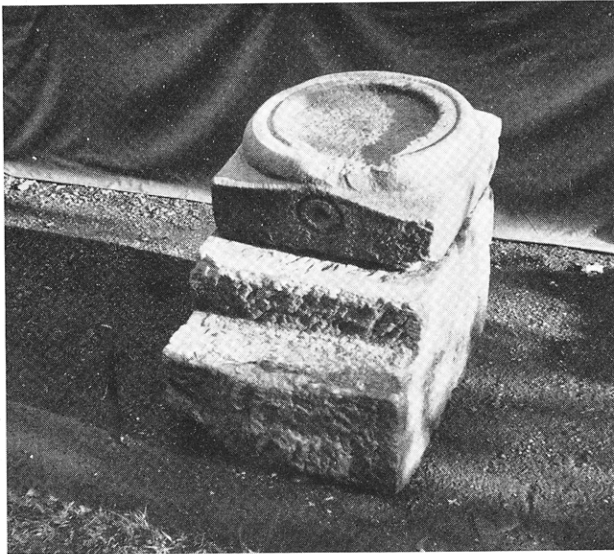

FIG. 12.—Base of Imperial statue from the *sacellum* in the headquarters, Bewcastle.

To face p. 210.

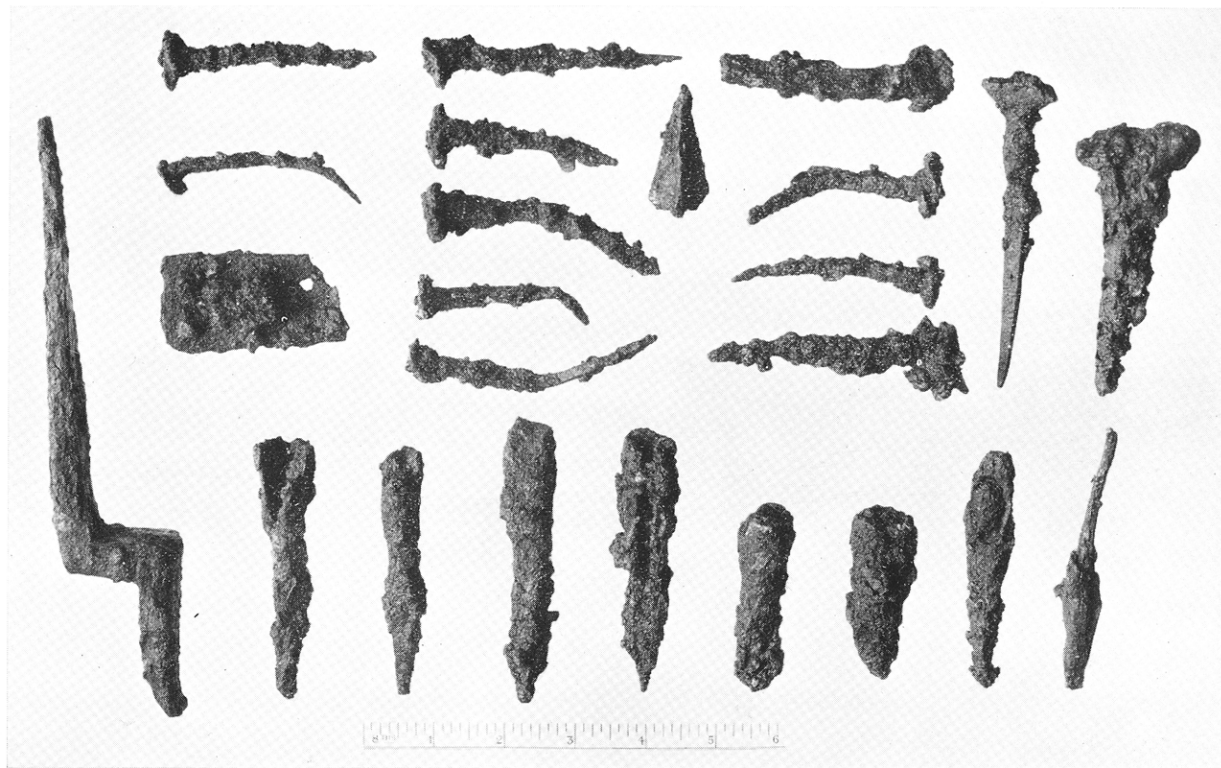

FIG. 13.—Iron thunder-bolt, nails, arrow-head and ferrules from the *sacellum*, Bewcastle.

traced in some detail. It shares the same west frontage as the *principia*, and is similarly built in all respects. The rapid dip of the subsoil precluded, however, a detailed planning of the southern portion of this block. Enough was learnt to establish that it formed a single unit covering at least 88 feet from north to south and 78 feet from east to west. The planning shows it to be a large domestic block, and therefore the commandant's house. Direct evidence for its date came from trench A, which yielded a small sealed deposit of typical third-century sherds (fig. 24, p. 224). A tiny fragment of moulded *verde antico* marble (see p. 236) may have come from its furnishing.

It should be observed that the foundations at the south end of the building had been carried very deep, as is noticeable at two points in trench A, the northernmost associated with a stone tank. The deepest foundations were encountered, however, on the inner wall of the west wing of the building, where a length of thirteen feet was exposed (see fig. 5), crossing trench B obliquely. Ground-level was marked by an offset and put-log hole for scaffolding, below which, to north of a westward respond, the wall exhibited eleven courses of faced foundation-work four feet deep. South of the respond, which had been largely cut away by a culvert draining the fourth-century levelling-raft (see p. 204), seven courses of walling above the foundation had been embodied in the levelled surface. The south end of the walling was marked by a large buttress. Without disclosing the bottom of the faced foundation, eight courses 3 feet 2 inches deep were uncovered on the adjacent main wall, carrying an offset put-log hole and three courses of upper masonry. The builders had evidently determined to terrace the floor-levels of the house on the side of the sandy hillock, taking their walls correspondingly deep. The north walls of the same building show how deep the true foundation-work

of clay and pitching also went. A comparable treatment of buildings on a steep hillside is to be seen in the *principia* and commandant's house at Housesteads.

It was now evident that the trenches had disclosed a third-century *principia* and commandant's house facing east. A glance at the general plan (fig. 4) will show these as roughly in line with the north and east ramparts of the hexagonal defences. It may therefore be regarded as certain that the principal buildings and *praetentura* of this period followed regular lines. The south gate, which Maughan excavated* in the rectory garden, and the north gate, behind Demesne Farm, will fall into line with the front of the *principia*; while the gap from which the east gate has been torn is visible, north of the position commonly supposed, on the axis of the *principia*. The Roman road (fig. 3) leads from it towards Herd Hill and Birdoswald. The only irregularity in the *praetentura* is thus the south-east rampart, now largely eroded by the Kirkbeck; this followed the steep edge of the plateau, where the conventional right-angle is excluded by the formation of the ground. The planning of the *retentura*, however, presented a more difficult problem. The line of its rampart, though Roman enough in its point-to-point course, is much less regular, and its relation to the central buildings remained to be defined. Search was therefore made for the first stable or barrack in the *retentura* behind the *principia*.

The east wall of this building was soon found (fig. 4), running across the fort, and was traced at intervals for a distance of 105 feet. Its north-east angle lay, as normally, behind the *principia*, at the junction of *viae decumana* and *quintana*. The foundations were laid with blue clay, as in the *principia* and commandant's house, while those at the south end were set in the marshy subsoil, above which plentiful third-century

Whellan, *History of Cumberland and Westmorland*, 631.



FIG. 14.—Silver plaques dedicated to Cocidius, with bronze letters and sheathing, from the *sacellum*, Bewcastle.
To face p. 212

tewaas_002_1938_vol38_0015



FIG. 15.—Altar used as filling above strong-room in the *sacellum*, Bewcastle.
To face p. 213

pottery (fig. 24) occurred on a floor-level associated with them. The date of the building and its relation to the main buildings of the third-century fort are thus fixed beyond doubt. Its orientation, however, differs sharply from that of the *principia* and *praetentura*, and matches that of the north-west side of the hexagon. Thus, it seems evident that the buildings of the *retentura* had been planned on new lines from the *via quintana* westward, in order to fit the hexagonal shape. This conclusion is strongly supported by the position chosen for the decuman gate, which is placed irregularly in the north-west side of the hexagon, exactly on the axis of the third-century *via decumana*.

The *porta decumana* was marked by a wide gap in the line of the north-west rampart. A trench across this gap soon disclosed, on its south side, the passage-wall (fig. 16) of a gateway, with inner and outer jambs constructed in large masonry. The outer jamb had rested upon three courses of foundation-work, of which the topmost block exhibited a pivot-hole, with run-way, and a prepared bed for upper stonework, now removed. The passage-wall of the gateway projected five feet beyond the outer jamb, and was thickened from 3 feet 6 inches to 3 feet 10 inches. It is built in fresh well-mortared masonry, resting upon broad footings set in the sandy subsoil. Its construction thus closely resembles that of the third-century buildings within the fort, with which it is alined. The gate had been built as a single unit, and the contemporary fort-wall, of deeply coursed masonry resting upon a roughly-trimmed plinth and footing-flag, abutted directly against it without a bond (see fig. 16). The rearward face of the fort-wall had been removed in making a post-Roman lime-kiln, together with the rampart-backing which had previously abutted against the back of the passage-wall. No guard-chamber existed.

The opening of the gateway was planned (fig. 4) as a

twin portal. Nine feet north of the inner jamb, the gravel road-bottoming was interrupted by a pitched foundation, five feet wide, which had once carried a central pier. At the same distance further north, the clay-and-cobble foundation of the north passage-wall appeared. Immediately beyond it, the clay rampart-backing came sharply into view, packed against the foundation. On this side also no guard-chamber existed. The cross-trench also produced the broken border of a large ansate panel, hinting that the gateway had been graced by a fine dedication-slab.

The architectural form of the gateway, a double portal without guard-chambers, is uncommon. The thick passage-walls, built independently from the fort-walls, suggest that it was provided with one tower over the archways instead of the lateral towers usually associated with guard-chambers. This would make it a compromise between the common type of single gate crowned with a tower, and the double gate with twin towers.

Failing an inscription, the date of the gateway must rest upon structural evidence. Like the *principia*, it is evidently the first stone building on its site, and its fresh masonry matches that of the third-century buildings with which it is alined. These correspondences attest its intimate connexion with the planning of the third-century fort. Formal proof of this connexion could, however, best be obtained by examining the rampart associated with the gateway.

The rampart-section (figs. 17, 18) was cut on the southwest side of the fort, midway between the west and southwest angles of the hexagon, where the remains appeared to be particularly well preserved. Before results are described, two illusions due to misleading surface indications may be dispelled. The supposed outer rampart is a recent boundary-dyke, which half-obscures an impressive single ditch at the foot of the main



FIG. 16.—Bewcastle, south passage-wall of south portal of west gate.

FIG. 17.—Section through south-west rampart, Bewcastle; showing third-century wall (in foreground) and wall of later fourth-century (in background).

bank. The bank itself, so artificial in appearance, was shown by a ten-foot trial-hole to be very largely of natural origin: for it is composed of coarse glacial drift untouched by human agencies. The Roman defences were perched upon its summit, and it can hardly be doubted that the desire to occupy this formidable bank was one of the factors which led to the abandonment of the normal rectangle in planning the fort.

The ditch was 10 feet 9 inches wide and 10 feet deep, with an inner slope rendered long and steep by the natural scarp. Six feet behind its lip came a well-built fort-wall, of freshly-quarried stone, five feet thick. It stands to a height of three very rough courses at the back, but has been robbed of all masonry above the footings at the front. The footing-flags had also slipped forward, but it is not clear whether this was due to subsidence or to stone-robbing. The rather loose upcast from the ditch had been heaped against the back of the wall in a mound fifteen feet wide, retained by a heel of stiff muddy clods. Below the mound, the turf-line covering the undisturbed subsoil could be clearly seen, and was cut by the foundations of the wall. The wall and mound thus appear not only as contemporary, but as the first structures laid upon the natural bank.

The relation of the wall and mound to the fort which they enclosed is shown by their subsequent history. Two important changes in plan, corresponding to alterations within the fort, were observed. The first of these involved an almost complete removal of the mound behind the fort-wall, which thus became a free-standing wall. There can be no doubt that the object was to obtain more space for buildings inside the fort; and these were in fact now brought closer to the wall, covering the previous *intervalum*. These buildings belong, as their construction shows, to the wattle-and-daub series of the fourth century. Beyond them, the newly-acquired space at the back of

BEWCASTLE · 1937 · SECTION THROUGH S-W. RAMPART

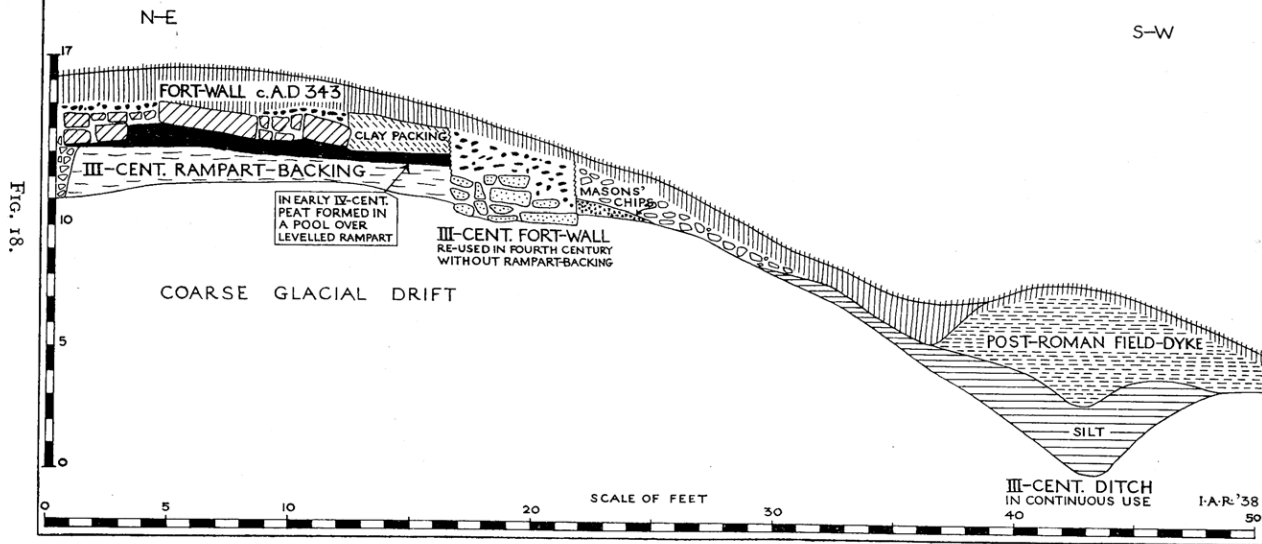

the fort-wall was neither paved nor drained, and became covered with an accumulation of dark humus, 9 inches deep.

The second change was much more drastic. The fort-wall, which had now seen two periods of use, was reduced to its foundations, and an entirely new wall, seven feet thick, was erected on the crest of the demolished mound. Its foundation was laid directly in the mud which had accumulated in the previous period, and was made of very large, roughly dressed and freshly quarried slabs. The very size of the slabs had baffled later stone robbers, who had removed only one small stone and had dented the rest by repeated but unavailing blows of the crow-bar. The massive foundations of this latest wall recall the late fourth-century fort-wall at Chesterholm. There can be no doubt that it belongs to the final reconstruction at Bewcastle, since a rough extension of the fourth-century buildings abuts against its back.

The relation of the earlier fort-wall to the history of the fort is now clear. Like the earliest stone buildings within the fort, it is built of fresh material and overlaid by two successive occupation levels. Further, it is this wall, forming part of the hexagonal plan, which abuts upon the stone gateway spanning the *via decumana* of the third-century fort, while that street is in turn diverted from its normal position in order to fit it. The evidence thus combines to show beyond doubt that the hexagonal plan belongs to a single fort of third-century origin. If this design were unrelated to the physical features of the site, it would indeed be a remarkable anticipation of late-Roman planning, based upon ballistics rather than castrametation. In fact, however, the irregularity is dictated by the configuration of the plateau on which it stands, where, as at Margidunum or Hofheim, it was impossible to lay out a rectangle of the size desired. Once the plan had been decided, future occupants of the fort

did not depart from it. The early fourth-century builders improved conditions by levelling the interior, but were content to accept the standing shell of the defences. The final reconstruction followed the same lines with little modification.

It will have been noted that no reference has yet been made to structures older than the third century, when it is evident that the visible fort was constructed. That these once existed, is shown by the lost building-inscription of Hadrian, already mentioned (p. 201). No second-century relic appeared, however, until the north wing of the third-century commandant's house was under examination. The first structure referable to this period was a large rectangular pit, lined with stones and clay, discovered just within this wing. It was partly filled by a massive third-century foundation, while the south-east angle of a projecting room had collapsed over its north-west corner. In the bottom of the pit lay a group of typical mid-second-century sherds. The east limit of the pit was only approximately defined, by showing that it did not extend into the Demesne bull-close; but the trench cut for this purpose produced contemporary structures of another kind. Below the level of an adjacent third-century wall, the sandy subsoil was cut by a sleeper-trench two feet wide, which yielded Hadrianic decorated Samian ware. Further early timber work was then added at two other points. At 32 feet east of the west wall of the commandant's house, the south wall of the north wing cut through a sleeper-trench nine inches wide and two feet deep: while the isolated north-to-south wall, 54 feet east of the west wall, overlay a mass of timber set in the sand.

This evidence leaves little doubt as to the character of the Hadrianic occupation. The timber buildings, occurring at the very centre of the plateau, must surely be included in the area of a fort, a point supported by the

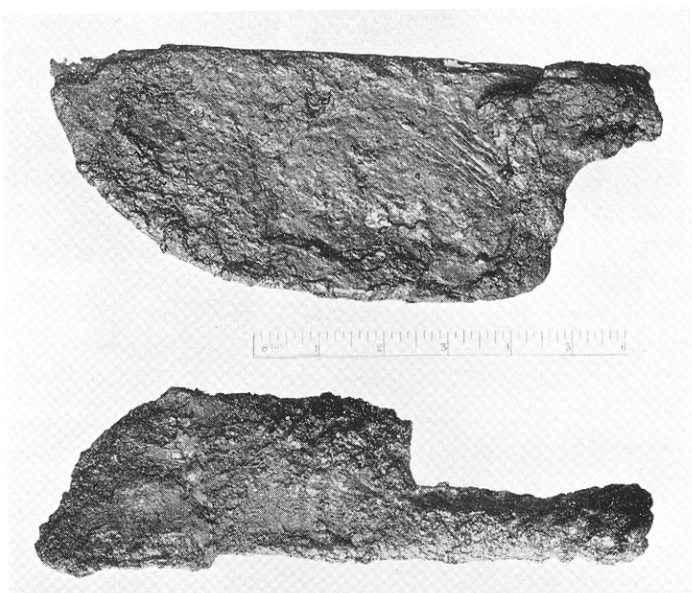

FIG. 19.—Iron cleavers from latest level, Bewcastle.



Back

Front

FIG. 20.—Bronze *genius*, unstratified, from Bewcastle.

To face p. 218.

regular alinement of the remains. That such a fort should contain timber buildings is not surprising when it is recalled that the Cumbrian sector of Hadrian's Wall, of which Bewcastle was an outpost, was first erected in turf and timber. The size and plan of the presumed fort remain unknown. No trace of its rampart is associated with the irregular lines of the third-century defences. But the correspondence in alinement between the timber buildings and the regular *praetentura* suggests that there may be some relation between the two, as yet undefined. Further excavation directed to this point would probably solve the question without difficulty. Equally obscure is the history of the occupation. It seems certain that the timber buildings were not replaced in stone during the second century. Had stone buildings then covered the site, waste material must have occurred in the foundations of the third-century buildings; while the conclusion that the early fort was always of timber provides the very best reason for the absence of such re-used stone. Historically, this would seem to imply the following conclusion. Either the timber fort at Bewcastle was occupied throughout the second century, and did not share in the reconstruction in stone which befell the Turf Wall; or it may have been abandoned when, for example, an occupation of Scotland was judged to have rendered the outpost unnecessary. No choice between these alternatives is to be made on the basis of present results.

iii. COARSE POTTERY FROM BEWCASTLE.

By MISS K. S. HODGSON and I. A. RICHMOND.

The pottery here illustrated is a representative selection of stratified sherds. The most interesting group comes from the strong-room of the third-century *principia* (figs. 6, 8). The later series is also of particular interest, since it does not include wares current upon Hadrian's

Wall after A.D. 367, and may therefore be taken to give a record of pottery in use during the first half of the fourth century. This group is moreover divided into two by a period of destruction, here equated with the Pictish War of Constans in A.D. 343.

Fig. 21. Period I. A.D. 122-197.

1. Rim of grey fumed jar, with metallic finish and very hard fabric; a typically Antonine piece. From early pit, trench A.
2. As no. 1, though typologically somewhat earlier. Same findspot.

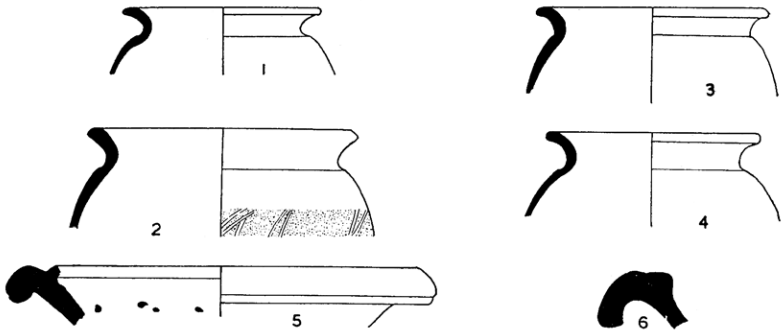
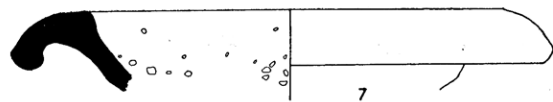

FIG. 21.—Bewcastle, sherds of period I, A.D. 122-197.

3. Rim of grey fumed cooking-pot, with cross-broaching: hard metallic fabric. From packing below third-century buildings, trench A.
4. As no. 3.
5. Rim of light-brown mortarium, pink in fracture: burnt black in places and of very hard fabric. Findspot as no. 1.
6. Rim of pink mortarium with traces of cream wash: soft fabric, stamped. From subsoil surface.

Fig. 22. Period II, A.D. 200-297. Mortaria from the sacellum and its strong-room, burnt at the end of this period.

7. Pink mortarium rim, with traces of cream wash and a little white and red grit sprinkled on the inside; heavily burnt. From the strong-room.
8. Red mortarium rim with haematite wash on exterior. From the strong-room.



7

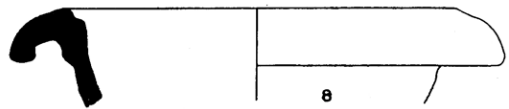

8



9

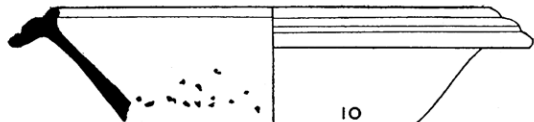

10

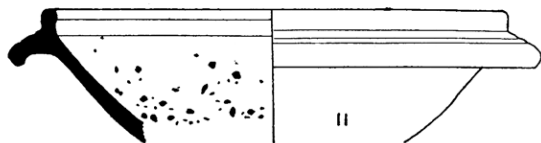

11

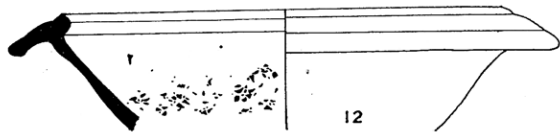

12

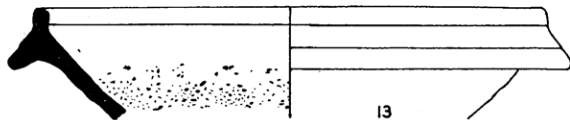

13

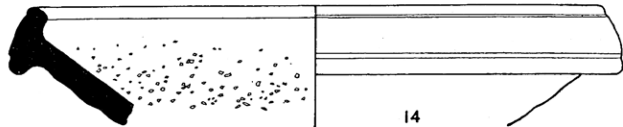

14

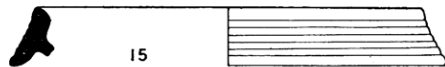

15

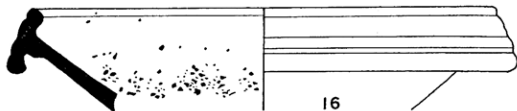

16

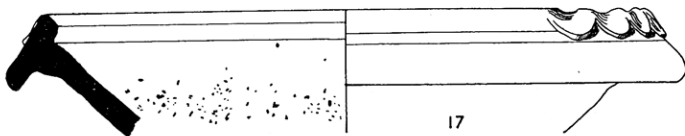

17

FIG. 22.—Bewcastle, sherds from the *sacellum* strong-room, A.D. 200-297.

9. Mortarium rim, cream in fracture, with light brown wash; slight dusting of coarse black grit on the inside; rather coarse fabric. From the strong-room.
 10. Pink mortarium in coarse fabric, with dusting of large black grit on the inside. It is very heavily calcined, and a fragment analysed by Dr. J. A. Smythe, Department of Metallurgy, King's College, Newcastle-upon-Tyne, yielded "a trace of oil." From the strong-room.
 11. Pinkish-brown mortarium rim, grey and pink in fracture, burnt black outside and sparsely sprinkled inside with black grit. Two surviving holes for suspension show its use* as a hanging-bowl, or, as the analysis of no. 10 strongly suggests, a hanging-lamp. From the strong-room.
 12. White mortarium rim, with a dusting of large black grit on the inside; hard fabric. North-east corner of *sacellum*.
 13. Hard white mortarium with a suspicion of light yellow wash and dark red grit dusted upon the inside. North-east corner of *sacellum*.
 14. White mortarium rim, heavily dusted on inside with small red grit. North-east corner of *sacellum*.
 15. Cream mortarium, white in fracture, burnt pinkish-brown in places; very hard fabric. From the strong-room.
 16. White mortarium rim, wall-sided in style, with traces of dark cream wash and a dusting of medium black grit on inside. From the strong-room.
 17. White mortarium rim with impressions of fingers on crest, and a sprinkling of dark-red grit on the inside. From the strong-room.
- Fig. 23. Period II, A.D. 200-297. Pottery from the strong-room, burnt in A.D. 297.*
18. White mortarium rim, with yellow cream wash and wavy line on overhanging lip: the inside is dusted with coarse black grit: rather coarse fabric. From the strong-room.
 19. Grey burnished jar, with girth-band left rough and decorated with eight nipples. Rather coarse fabric, grey in fracture. From the strong-room.

* It was pointed out to Miss Hodgson by Mrs. Nelson Young that these mortaria showed, in contrast with those from the rest of the fort, a marked absence of trituration. In other words they had not been used for their usual purpose as mixing-bowls. This goes to confirm the special use that may be inferred from other evidence.

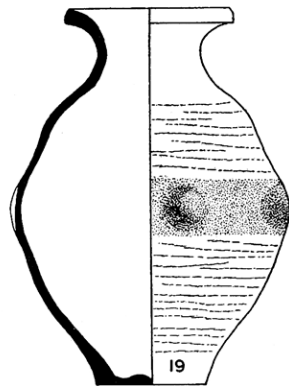
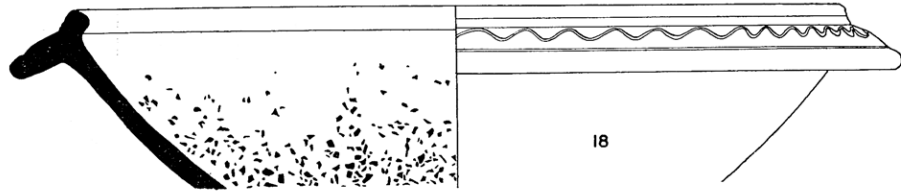
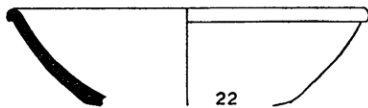
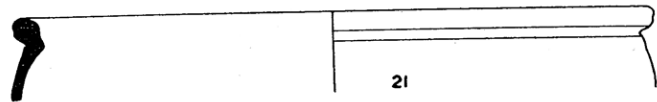
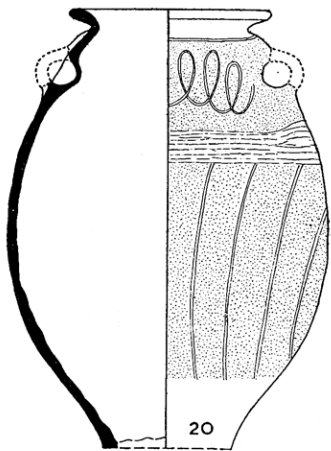

FIG. 23.—Bewcastle, sherds from the *sacellum* strong-room, A.D. 200-297.

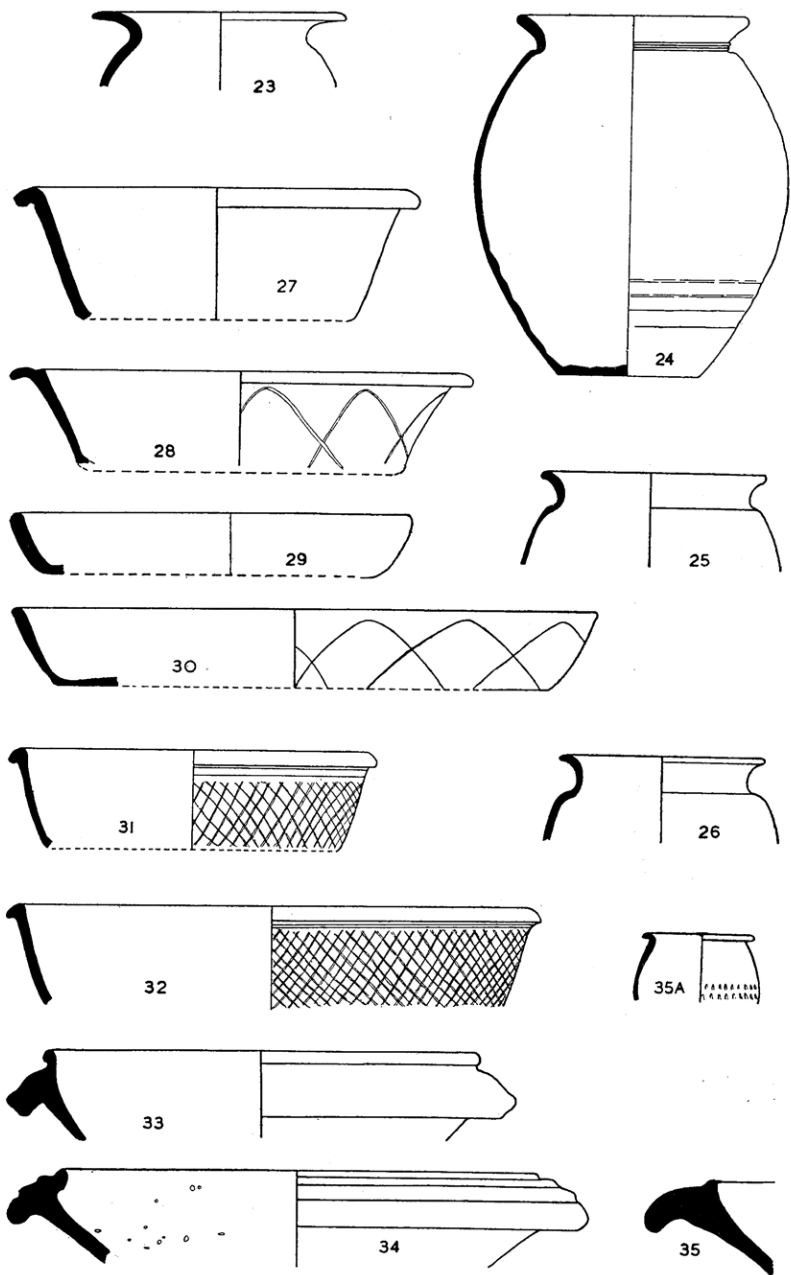

FIG. 24.—Bewcastle, sherds of A.D. 200-297.

20. Light-grey two-handed jar, with scroll on shoulder and burnished girth-band bordering widely spaced almost vertical broaching on the belly; hard fabric. From the strong-room.
 21. Rim of red jar; grooved for a lid, with external haematite wash; hard fabric embodying a little white grit. From the strong-room.
 22. Late example of Samian ware, Dragendorff 31. From the strong-room.
- Fig. 24. Period II, A.D. 200-297. Miscellaneous wares.*
23. Black polished cooking-pot. Barrack-building.
 24. Grey jar of hard thin fabric, sharply scored towards base with wheel-marks. Barrack-building.
 25. Grey cooking-pot, with fine hard finish. Barrack-building.
 26. As 25 in type and findspot.
 27. Grey fumed platter. In filling below fourth-century level, trench B.
 28. Black fumed platter, coarse in fracture. Barrack-building.
 29. Grey platter, heavily burnt; coarse in fracture. Trench A, in filling below fourth-century level.
 30. Grey platter of hard coarse fabric, embodying a little white grit. Trench A, commandant's house.
 31. Hard grey fumed platter with cross-broaching. As 30.
 32. Hard black platter, with cross-broaching. As 30 and 31.
 33. Pink mortarium rim washed with haematite on exterior; deep pink in fracture; a very uncommon type. In filling below fourth-century level, trench B.
 34. Rim of pink mortarium with haematite wash on exterior. The combination of the normal third-century overhanging rim with grooves like those of a fourth-century hammer-headed mortarium forms an interesting hybrid. Findspot as 33.
 35. White mortarium rim, light pink in fracture: rather coarse fabric. Trench A, commandant's house.
 - 35a. Rim of red rouletted beaker: fine fabric, with a very slight admixture of mica dust. Trench A, commandant's house.
- Fig. 25. Period III. A.D. 297-c.A.D. 343. While the closing date of this period is not certain, A.D. 343 is the earliest limit likely.*
36. Black polished cooking-pot. Building behind rampart.
 37. Black polished cooking-pot. Trench A, barracks.
 38. Black polished cooking-pot. Trench A, barracks.

39. Grey fumed cooking-pot, with band of cross-broaching on shoulder. Trench A.
 40. Rim of grey fumed beaker, with bead-rim and handle. Trench A.
 41. Grey polished jar, grooved on shoulder: rather soft fabric. Trench B.
 42. Grey cooking-pot in hard rather coarse fabric. Trench A.
 43. Rim of hard grey jar with burnished exterior and inside of rim. Trench.
 44. Polished black cooking-pot. Building behind rampart.
 45. Grey cooking-pot in hard metallic fabric. Trench A.
 46. Rim of pink mortarium, with haematite wash on outside and sprinkling of pink grit inside. A third-century survival. Trench B.
 47. White mortarium rim, approaching wall-sided type: the inside dusted with black grit. Trench A.
 48. Cream mortarium dusted inside with large black grit; very hard fabric. Trench A.
 49. Pink mortarium rim, with deep pink fracture; hard, somewhat coarse fabric. Trench A.
 50. Black platter, grey in fracture; coarse fabric. Trench A.
 51. Rim of grey fumed platter. Trench A.
 52. Black fumed platter, heavily burnt; rather coarse fabric. Trench A.
 53. Rim of platter, burnt pinkish-brown. Trench A.
 54. Grey fumed platter of very hard fabric and metallic finish. Trench B.
- Fig. 26. Miscellaneous wares of periods III (55-59) and IV (60-68). Period IV, beginning at earliest in A.D. 343, does not extend beyond A.D. 367.*
55. Black polished cooking-pot, with cross-broaching on shoulder. In filling below latest level, Trench B.
 56. Black fumed cooking-pot. In filling below latest level. Trench A.
 57. Hard grey cooking-pot, burnt light-brown. As 56.
 58. Dark-grey fumed platter; coarse fabric. As 55.
 59. Grey fumed platter; hard fabric. In filling below latest level behind rampart.
 60. Polished black cooking-pot. Trench A, latest level.
 61. Black polished cooking-pot, burnt light brown. Trench A, latest level.
 62. Grey fumed jar, cream in fracture; hard fabric, metallic finish. Level IV, above third-century barrack.

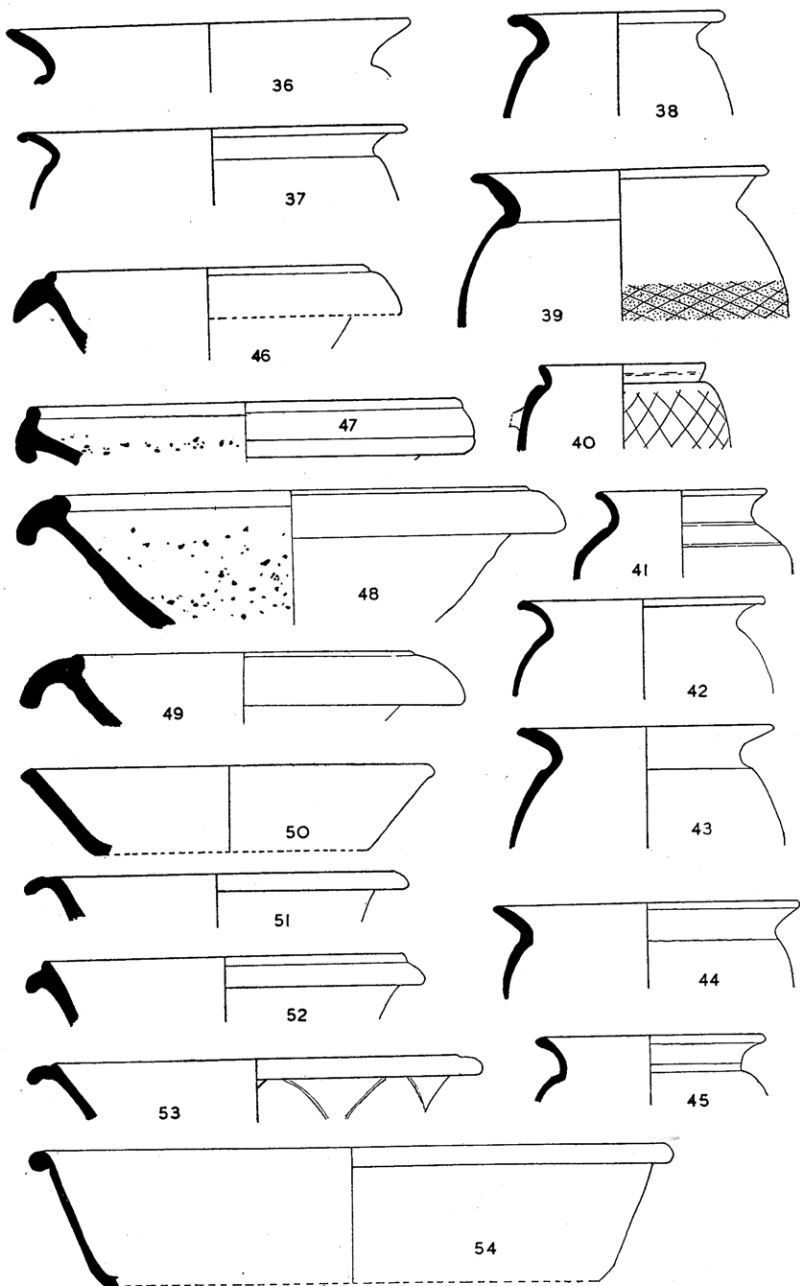

FIG. 25.—Bewcastle, sherds of A.D. 297-c.A.D. 343.

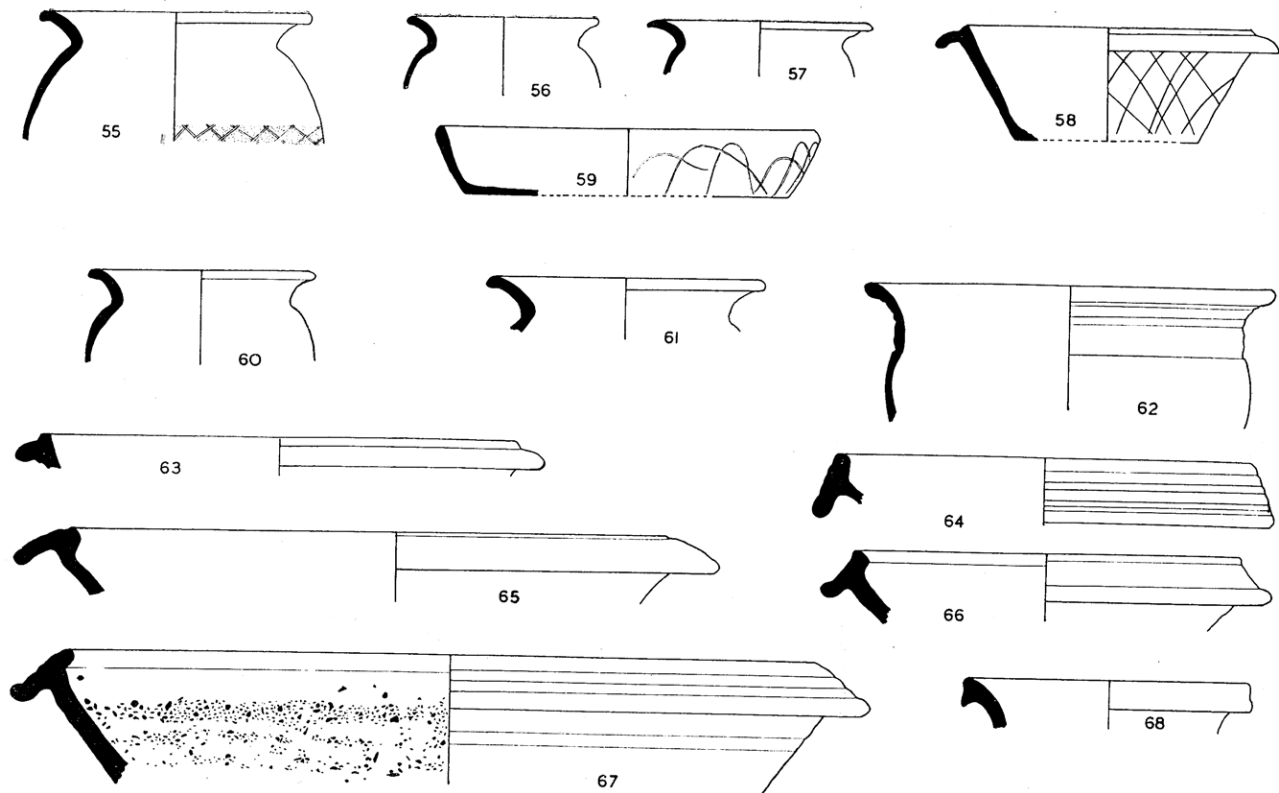

FIG. 26.—Bewcastle, sherds of A.D. 297-c. A.D. 343 (nos. 55-9) and c. A.D. 343-367 (nos. 60-68).

63. Black fumed platter; coarse fabric with a little white grit. As 60.
64. Rim of white mortarium; hard fabric. As 62.
65. White mortarium, burnt black in places. Trench A, latest level.
66. White mortarium rim; hard fabric. As 62.
67. White mortarium, heavily dusted on the inside with grit of all sizes, mostly red in colour. Trench A, latest level.
68. Rim of red jar, heavily burnt. Hard fine fabric. Trench A, latest level.
- Fig. 27. Surface material, unstratified, but representative of the late periods.*
69. Black polished cooking-pot.
70. Black cooking-pot in vesicular ware, but lacking the groove found on such vessels after A.D. 367.
71. Black polished cooking-pot.
72. As 70.
73. Grey handled beaker, resembling no. 40, but without cross-broaching. Soft fabric.
74. Pink mortarium rim, with traces of red wash in grooves, hard fabric.
75. White mortarium rim, with cream wash; hard fabric.
76. White mortarium, with yellow wash, and heavy dusting of mostly small black grit inside, hard fabric.
77. White mortarium with yellow wash; hard fabric.
78. Jug-neck in hard red fabric; survival of screw type.



Stamp on mortarium, p. 220, No. 6.

iv. NOTE UPON MEDIEVAL POTTERY FROM BEWCASTLE.

By JOHN CHARLTON.

All the pottery submitted was unstratified and so can be classified only on typological grounds.

None of the sherds resembles any example of pre-Conquest pottery so far known to us. The earliest group

comprises six brown sherds which belong probably to the 13th century, though one sherd, with traces of scratch-marks, and another with 'knife-technique' might hint at a 12th-century date.

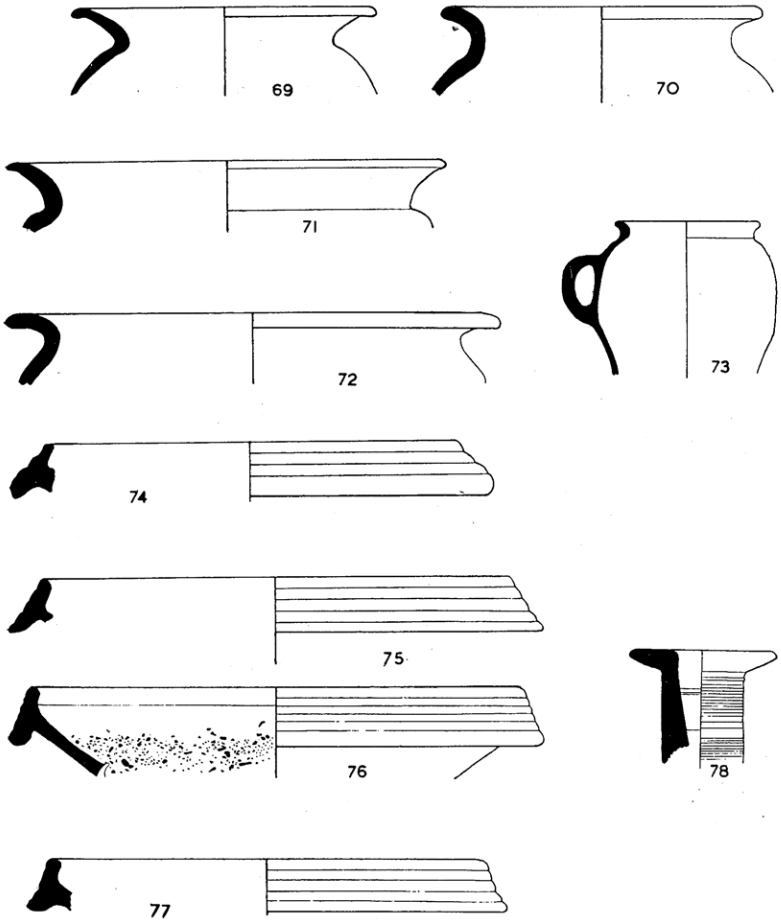

FIG. 27.—Bewcastle, sherds strewn above latest level.

A larger group of grey sherds, about 15 per cent. of the total, is probably also of the 13th century; their fabric recalls small 12th-century cooking-pots of S.E. Scotland, while the clear-cut mouldings of their rims agree more with Edwardian finds from the same area.

Most of the vessels represented, however, are glazed pitchers similar to those found at Dunstanburgh Castle and therefore not earlier than the 14th century (*AA.*⁴ xiii, 285 ff); they are generally tall vessels, about 18 ins. high, of smooth grey ware with green or brownish-green glaze; bases are rounded without thumbing and there may be more than one handle. At least two of the Bewcastle pots had bung-holes near the base. The type and its main variations are described and a restored type-specimen is figured in *PSAN*³, V, 231-2.

The other fragments are of small pitchers, with few noteworthy features. It should be observed, however, that the late 15th-century bulbous pitcher is absent.

There is only one decorated fragment: it bears a small moulded frond—an ornament known from several N.E. sites (*PSAN.*, *loc. cit.*).

In conclusion it may be noted first, that the sherds appear to be contained within the dates 1200-1450, with the majority in the latter half of the period; second, that probably all were made within or near the bounds of Northumbria.

[By way of comment upon these conclusions it may be added that there appears to be a complete gap between the Roman and medieval periods, despite the presence on the site of the famous Anglian cross. It does not look as if that cross had been planted on a populated site. The medieval pottery, on the other hand, usefully confirms the Edwardian date now generally accepted for the castle and church. I.A.R.]

v. REPORT UPON THE COINS FROM THE
SACELLUM AT BEWCASTLE.

By C. H. V. SUTHERLAND.

The following 13 coins come from the floor of the *sacellum* strong-room at Bewcastle (see p. 208). Measurements are given in millimetres, and the reference *RIC.* is to Mattingly-Sydenham, *Roman Imperial Coinage* (vol. V, parts 1 and 2). The coins are all *antoniniani*, or copies of *antoniniani*.

1. *Orthodox.* 22 mm. Claudius II. *Rev.* SPES PVBLICA advancing l. (*RIC.* 102F). *Fresh.*
2. *Orthodox.* 21 mm. ? Tetricus II. *Rev.* Oxidised and illegible. *Medium wear.*
3. *Orthodox.* 19.5 mm. Tetricus I. *Rev.* VIRTVS AVGG Soldier stg. l. (*RIC.* 148). Struck in pale copper, not unmixed with brass alloy. *Medium wear.*
4. *Orthodox.* 18 mm. No *obv.*: brockage (i.e. *rev.* type incuse) of its own *rev.* type, SALVS AVG (altar) (cf. *RIC.*, Tetricus i, no. 126). *Medium wear.*
5. *Orthodox.* 17 mm. Tetricus II. *Rev.* [SPES AVGG] advancing l. (*RIC.* 270). Flan perhaps reduced. *Much worn.*
6. ? *Copy.* 18.5 mm. Tetricus I. *Rev.* SPES PVBLICA advancing l. (cf. *RIC.* 135-6). Uneven flan: clipped. *Considerably worn.*
7. ? *Copy.* 17 mm. Tetricus I. *Rev.* PAX AVG stg. l. (cf. *RIC.* 100). Struck in what appears to be *orichalcum*, or brass. *Medium wear.*
- 8.* *Copy.* 16 mm. Tetricus II. *Rev.* [PIETAS AVGG] Priestly emblems (cf. *RIC.* 254 ff).
9. *Copy.* 15 mm. Prototype uncertain. *Rev.* PIETAS [Augustorum] Priestly emblems, † as on no. 8. *Fresh to worn.*
10. *Copy.* 13.5 mm. (? Tetricus I). *Rev.* SALVS AVG, as on no. 9. Struck in what seems to be a copper-orichalcum alloy. *Worn.*
11. *Copy.* 13 mm. Prototype uncertain. *Rev.* Illegible: oxydised. *Fair condition.*
12. *Copy.* 12.5 mm. Tetricus I. *Rev.* Uncertain female fig. stg. *Medium wear.*

* *Obv.* reads—]VPSVTETRI[—]. For the spacing of the *rev.* legend, cf. *Num. Chron.*⁵ xvi (1936), p. 42.

† Cf. *Num. Chron.*⁶ xiv (1934), p. 100, Class B, nos. c and f.

13. — 14 mm. *Obv.* and *rev.* completely illegible. Probably radiate. Flan uneven.

Since this little handful of coins was scattered and lost in the looting of the *sacellum* strong-room in A.D. 297, it may be regarded as a pattern of the small change officially in use at that time. Looked at in the light of this conclusion, the coins have several points of interest. Excluding the doubtful coins, we note that there are as many imitations as there are orthodox coins. Of the latter, only one (no. 1) is in the tradition of the fine, broad *antoninianus*: the others are all of the Gallic mints, and consequently poor productions. The types copied are those most commonly used for this purpose: *Pax*, *Spes*, *Pietas* (*Augustor*), *Salus* constantly occur on copies; * and *Spes* and *Salus* appear as prototypes in the present group. The size of the coins seems to drop steadily, from the 22 mm. of Claudius II, through the 21, 19.5, 18 and 17 mm. of the other orthodox pieces, falling from 18.5 to 12.5 mm. in the case of the copies. Signs of change are apparent in the metal also. No. 4 is an orthodox coin, but includes more than mere *aes* in its yellow composition: no. 10, a copy, shows a similar tinge, while no. 7, probably a copy, is of the pure colour of the "orichalcum" *sestertii* or *dupondii* of an earlier period. Can it be that this unusual composition (and brass was normally valued higher than copper; hence brass *sestertii* and *dupondii*) is the result of the melting down of the earlier coins of large module, the metal of which was then used for the production of *antoniniani*, whether orthodox or imitated? Reflection will show that the occurrence of *sestertii*, *dupondii* and even *asses*† of the former years in hoards of *antoniniani* buried between A.D. 260 and 300 is extremely

* See the present writer's *Coinage and Currency in Roman Britain*, pp. 132 ff.

† The Eynsham hoard supplies a rare example: cf. *Num. Chron.*⁵ xvi (1936), p. 251 ff.

exceptional: possibly, then, they had been largely withdrawn and put in the melting-pot.

These coins, therefore, suggest a progressive decline in the coinage current at Bewcastle, for the Verulamium *minimi* have suggested that, whereas reduction to true minim size may be no more than a sign of a purely local token coinage based (perhaps under Carausius) on a declining and perhaps demonetized Gallic series, coins of poor style, and of module fluctuating between the orthodox and the true minim, are money of necessity, in the fullest sense. That this is the explanation of the present coins is suggested also by the curious fact that not a single piece of Carausius and Allectus is included. True, this is not a hoard, and the marauders may have even thrown aside some of our coins as poor and undesirable, concentrating on better pieces: yet this is not really probable, and, rare though coins of Aurelian and Probus are in the south, southern figures for Carausius and Allectus cannot fail to contrast with absence at Bewcastle. It therefore appears as if the coinage of Carausius and Allectus—so common in the south, the midlands, and south Wales—may have been distinctly less common in the extreme north: and its circulation in bulk would in any case be handicapped by insecurity or actual threat of invasion. Of the present coins, the piece of Claudius II is the sharpest, and saw but little circulation; the rest were in currency for varying periods—none for a very short time only—and the copies were perhaps produced in the north to make up for the persistent lack of subsequent new issues.

vi. REPORT UPON EARTH-SAMPLES FROM
BEWCASTLE.

By A. RAISTRICK, M.A., PH.D.

I. *Section of rampart-backing, covered by humus and resting on subsoil.*

Two distinct layers of material are present. The upper layer is a thick, rather clayey turf, with a dark humus layer at the top. The humus contains a little pollen, entirely hazel and willow, with a fair quantity of grass spores also. The bulk of the layer is clay with pebbles, partly broken up by grass roots, etc. It shows some signs of being disturbed and is almost certainly a sub-soil 'lump' placed on top of the levelled 'in situ' material of the lower layer.

The lower layer is a normal sandy sub-soil which seems to be in undisturbed condition. At the top of it there is a thin humus layer, which has yielded no pollen, but which has been sufficient to hold up a thin iron pan, which has heavily stained the base of the upper layer.

II. *Material from the levelled rampart.*

A peaty soil, sandy towards the base. A fair quantity of humus is present, but pollen is rather scarce. The plants represented are willow, hazel and, very rarely, oak. Sedges and marshy detritus are also present in moderate quantity.

III. *Material from the heel of the levelled rampart.*

This is mainly clean sand with a small clay fraction present.

There is a small iron pan, but no humus. The material has none of the characteristics of a soil. It resembles a very sandy silt, and may be matched by material from a stream-terrace or a small silted pond area.

IV. *Material from the bottom of trench A.*

This sample has three clear layers. The top layer is a clean, normal grey silt, with very little clay content. A clean-cut face, however, shows most clearly that this is in irregular lumps which are piled up anyhow, the bedding going every possible way in the different lumps. It suggests tipped material. The middle layer is a few inches of charcoal mixed with peaty silt. The charcoal is that of brushwood, small twigs and branches up to one inch in diameter, largely hazel with a little willow present. The peaty material contains a little grass, partly charred, and fragments of willow and hazel. The lowest layer is a chaotic mixture of peaty silt, clay lumps, and charcoal, obviously tipped material, which

has presumably been shovelled off a partly cleared surface where vegetation has been fired.

The picture that emerges vividly from this material, is the clearing of a site following burning of brushwood, namely, hazel scrub with localised willow patches. Soil, turf and burnt material were all dumped together. Further brushwood cuttings were next piled on top and burned *in situ*, producing the charcoal layer. Finally, clean subsoil and silt strippings or levellings were thrown in to fill the hollow and bury the rubbish.

V. *Silt below earliest walling of barrack, in trench E.*

A normal silt with pebbles, sandy and iron stained at the top, with no humic material, and no evidence of disturbance.

vii. REPORT ON ROCK SPECIMEN, A FRAGMENT OF
CARVED MOULDING.

By K. ST. JOSEPH.

The fragment was found on the surface outside the third-century barrack-building. It is obviously a waif from the destruction of rich furnishings in the *principia* or commandant's house.

The specimen is a labradorite porphyrite, now considerably decomposed. The rock consists essentially of abundant, large phenocrysts of a plagioclase that approaches labradorite in composition together with smaller crystals of hornblende, set in a fine-grained ground-mass. The feldspars have the usual, grey polarisation colours, a refractive index of about 1.56, and exhibit albite twinning in narrow lamellae. Zonary banding is common, the interior being as usual the more calcic part. Many of the crystals have rounded corners and have undergone some resolution; they are all now turbid as a result of advanced alteration. A few phenocrysts of hornblende occur as small hexagonal prisms, now pseudomorphed by chlorite, showing characteristic ultra-blue interference tints; but occasional relics of the hornblende remain in the centre of the crystals. The ground-mass of the rock probably consisted originally of a felt of small, lath-shaped feldspar crystals and grains of hornblende; it is now greatly altered though sometimes the outlines of feldspar laths can be distinguished. The hornblende has passed chiefly to green, pleochroic chlorite with the production of small grains of magnetite.

The sample shows a very close resemblance both microscopically and in thin-section to specimens of labradorite porphyrite from Marthonisi, South Morea, Greece. This latter rock, which is classed as a variety by Tröger,* has been used fairly extensively in modern times under the name of *porfido verde antico* for the manufacture of small, polished ornaments.

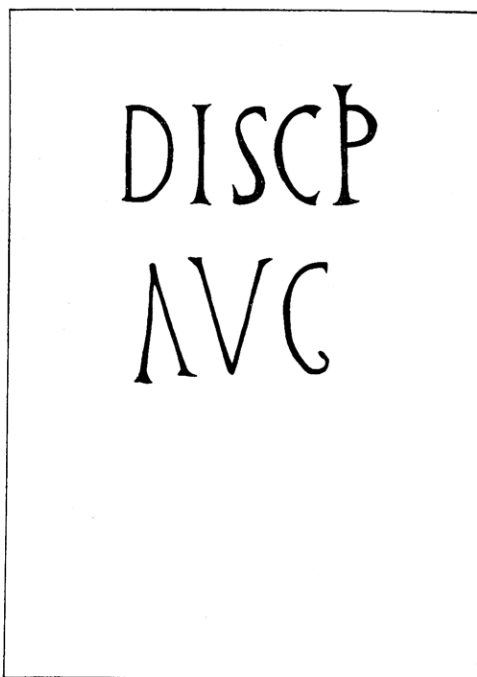

E.B. - '37

Altar to Discipline, from Bewcastle.

* W. E. Tröger, *Spezielle Petrographie der Eruptivgesteine*, Berlin, 1935 p. 330, no. 966.