



Society of Antiquaries
of **Scotland**

SCOTTISH ARCHAEOLOGICAL INTERNET REPORTS

e-ISSN: 2056-7421

The New Street Gasworks, Caltongate: archaeological investigation of a major power production complex in the heart of Edinburgh and its significance in the industrial development of Britain

How to cite:

McLaren, D, Roy, M & Wilson, D 2022 'The New Street Gasworks, Caltongate: archaeological investigation of a major power production complex in the heart of Edinburgh and its significance in the industrial development of Britain', *Scottish Archaeological Internet Reports* 101.
<https://doi.org/10.9750/issn.2056-7421.2022.101>

Visit <http://journals.socantscot.org/index.php/sair> to see the series homepage.

OPEN  ACCESS

Please note:

This document is the publisher's PDF of a report published in *Scottish Archaeological Internet Reports*. This version has been peer-reviewed and contains all final editorial corrections and pagination.

Copyright © 2022 Dawn McLaren, Mike Roy, Donald Wilson and the individual contributors. Except where otherwise noted, this work is licensed under Creative Commons Attribution-NonCommercial 4.0 International licence (CC BY-NC 4.0)
<https://creativecommons.org/licenses/by-nc/4.0/>

Requests for permission to reproduce material from a SAIR report that is marked as exempt from the CC licence should be made to the publisher at <https://www.socantscot.org/publications/copyrightpermission> as well as to the author, illustrator, photographer or other copyright holder.

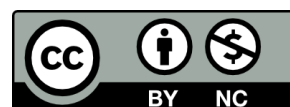

The New Street Gasworks, Caltongate: archaeological investigation of a major power production complex in the heart of Edinburgh and its significance in the industrial development of Britain

Dawn McLaren,¹ Mike Roy¹ and Donald Wilson²

With contributions by Dennis Gallagher,³ George R Haggarty,⁴ Andrew Morrison,¹ Jackaline Robertson,¹ Lynne Roy,¹ Diana Sproat,¹ Clare Thomas⁵ and Ian West⁶

Illustrations by Gemma Hudson, Jamie Humble, Sam O'Leary and Sarah Munro

Author contact

Dawn.McLaren@aocarchaeology.com

Funding

New Waverley Advisors Ltd

- 1 AOC Archaeology Group, Unit 7a, Edgefield Industrial Estate, Loanhead, EH20 9SY
- 2 Headland Archaeology (UK) Ltd, 13 Jane Street, Edinburgh, EH6 5HE
- 3 dbgallagher100@gmail.com
- 4 haggartyg@aol.com
- 5 stillnessthomasiota10@hotmail.co.uk
- 6 University of Leicester, University Road, Leicester, LE1 7RH

e-ISSN: 2056-7421

DOI: <https://doi.org/10.9750/issn.2056-7421.2022.101>

Published by the Society of Antiquaries of Scotland

Society of Antiquaries of Scotland
National Museums Scotland
Chambers Street
Edinburgh EH1 1JF
United Kingdom
www.socantscot.org

Registered Scottish charity no. SC010440
Managing Editor: Adela Rauchova/Kate Bailey
Copy-editor: Susan Milligan
Production: Raspberry Creative Type, Edinburgh

TABLE OF CONTENTS

List of illustrations	v
List of tables	ix
1. Abstract	1
2. Introduction	2
2.1 Overview	2
2.2 Location	4
2.3 Geology	4
3. The history of Canongate and the New Street Gasworks	5
3.1 Before the burgh (<i>c</i> 8000 BC–AD 1128)	5
3.2 The medieval burgh (AD 1128– <i>c</i> 1560)	5
3.3 Post-medieval Canongate (AD <i>c</i> 1560–1900)	6
3.4 New Street and its vicinity	11
4. The New Street Gasworks and Edinburgh’s gas industry	14
4.1 An introduction to the development of the gas industry	14
4.2 The techniques and technology of early gas production, <i>by Mike Roy, incorporating research by Ian West</i>	15
4.3 The development of the gas industry in Scotland and the beginnings of Edinburgh’s gasworks	20
4.4 The further development of the New Street Gasworks	22
4.5 The Gasworks and its surroundings: evidence from historic maps and plans	29
4.6 The Gasworks and contamination	36
4.7 Working conditions and the labour force	39
4.8 Survival of Gasworks structures	40
4.9 Scottish Motor Traction	42
5. Previous archaeological works	44
6. The excavated evidence: New Street Gasworks	45
6.1 Introduction	45
6.2 The fieldwork of 2006–2008	45
6.3 Results of the fieldwork: overview	45
6.4 Phase 1 (before 1818)	49
6.5 Phase 2 (1818– <i>c</i> 1845)	52
6.6 Phase 3 (<i>c</i> 1845– <i>c</i> 1875)	60
6.7 Phase 4 (<i>c</i> 1875–1906)	73
6.8 Phase 5 (1906–1928)	94
6.9 Phase 6 (1928 onwards)	94
7. Taphonomy of the backland soils, by Lynne Roy	96
7.1 Introduction	96
7.2 Stratigraphy	96
7.3 Methodology	96
7.4 Results	97
7.5 Discussion	98

8. The ecofact evidence: New Street Gasworks, by Jackaline Robertson	101
8.1 The animal bone	101
8.2 The macroplant remains	102
8.3 The shell	102
9. The artefact evidence: New Street Gasworks	103
9.1 Introduction	103
9.2 The architectural plasterwork, <i>by Diana Sproat</i>	103
9.3 The ceramic retort, <i>by Ian West</i>	105
9.4 The bricks and tiles, <i>by George R Haggarty</i>	110
9.5 The ceramics, <i>by George R Haggarty</i>	111
9.6 The clay tobacco pipes, <i>by Dennis Gallagher</i>	120
9.7 The copper alloy objects, <i>by Andrew Morrison</i>	128
9.8 The iron objects, <i>by Andrew Morrison & Dawn McLaren</i>	130
9.9 The lead objects, <i>by Andrew Morrison</i>	141
9.10 The glass, <i>by Andrew Morrison</i>	143
9.11 The industrial residues, <i>by Dawn McLaren</i>	145
9.12 The leather, <i>by Clare Thomas</i>	146
9.13 The worked bone, <i>by Dawn McLaren</i>	150
9.14 The worked stone, <i>by Dawn McLaren</i>	150
9.15 The wood, <i>by Andrew Morrison & Dawn McLaren</i>	151
10. Discussion	152
Appendix 1. The excavated evidence: New Waverley Areas PA1(A) and PA1(B)	156
A.1.1 Introduction	156
A.1.2 Historic background to PA1(A) and PA1(B)	156
A.1.3 Results of the PA1(A) archaeological works	156
A.1.4 Results of the PA1(B) archaeological works	160
A.1.5 The historic building recording, <i>by Diana Sproat</i>	165
A.1.6 The ecofact and artefact assemblages, <i>by Jackaline Robertson, George R Haggarty</i> <i>& Andrew Morrison</i>	166
A.1.7 Discussion	169
11. Acknowledgements	170
12. References	171
12.1 Cartographic sources	171
12.2 Documentary sources	172
12.3 Digital sources	173
12.4 Secondary sources	174

LIST OF ILLUSTRATIONS

1.	Early engraving of the City of Edinburgh: vista from St Anthony's Chapel showing the New Street Gasworks chimney at the centre	2
2.	Location of Caltongate South, Caltongate North, PA1(A) and PA1(B)	3
3.	Detail from Alexander Kincaid's 1784 <i>Plan of the City and Suburbs of Edinburgh</i>	5
4.	Detail from 1647 <i>Bird's Eye View of Edinburgh in 1647 by James Gordon of Rothiemay</i> . Edinburgh: W & AK Johnston (published c 1870)	7
5.	Detail from <i>Plan of the City and Castle of Edinburgh by Willm Edgar architect anno 1765</i>	8
6.	Detail from <i>This Plan of the City of Edinburgh and its Environs, 1817</i> . Edinburgh: Kirkwood & Son	9
7.	Detail from <i>Kirkwood's New Plan of the City of Edinburgh, 1821</i>	10
8.	Ordnance Survey 1854 (Surveyed 1852) <i>Edinburgh</i> Sheet 30, scale 1:1056	12
9.	Edinburgh, New Street Gasworks survey site plan, Alex Masterson, Engineer, Edinburgh and Leith Corporation's Gas Commissioners EDD 747/1	13
10.	New Street Gasworks retort bench prior to demolition	16
11.	Schematic diagram of a simple gasworks process	17
12.	Horizontal retort benches and double furnace in process of demolition	18
13.	Engraving of the City of Edinburgh from Calton Hill showing the New Street Gasworks Chimney	25
14.	The New Street Gasworks main chimney seen through the Edinburgh smog in the late 19th century	26
15.	Removal of the horizontal retorts in 1911	27
16.	Detail from J Wood's 1823 <i>Plan of the City of Edinburgh, including all the latest and intended improvements</i> . Edinburgh: P Brown & T Nelson	28
17.	Detail from <i>Plan of Edinburgh and Leith. From the best Authorities. Engraved expressly for the Letter Carriers Directory, By W.H. Lizars, 1835</i>	29
18.	Detail from J Kay's 1836 <i>Kay's Plan of Edinburgh</i>	30
19.	Detail from A Lancefield's map, <i>Johnston's plan of Edinburgh & Leith</i> . Edinburgh: W & A K Johnston, 1851	31
20.	Ordnance Survey 1881 (Revised 1877) <i>Edinburgh</i> Sheet 30, scale 1:1056	32
21.	The coal shed in operation prior to demolition	33
22.	Above-ground piping of the New Street condensers prior to demolition	33
23.	Detail from Ordnance Survey 1895 (Surveyed 1894) <i>Edinburgh</i> Sheet III.8.12, scale 1:500	34
24.	Detail from Ordnance Survey 1908 (Revised 1905) <i>Edinburghshire</i> Sheet 003.08 (includes: Edinburgh), scale 25 inch to the mile	35
25.	Blind openings in eastern external wall of Gasworks on Tolbooth Wynd	40
26.	Workshop building from the south-east	42
27.	Plan of Caltongate South excavation	46
28.	Plan of Gasworks excavations including Caltongate North	47
29.	Plan of Phase 1 features	48
30.	Sections through test pits showing Phase 1 garden soil deposits	49
31.	Stone well (N0256) cut through the garden soils and alluvial deposits	50
32.	Remains of a stone wall (N0274) from the north	51
33.	View of stone walls (S001) and (S008), taken from the south-east	52
34.	Plan of Phase 2 features	53
35.	General view of the large stone-walled room to the south-west including floor (N0083)	54
36.	Phase 2 features overlain with features on Kirkwood's 1821 map	55
37.	Flue (J0322) aligned north/south, from the east	56

38.	Plan of Caltongate North showing all the features recorded	57
39.	Detail of stone buttress (R046), taken from the south	58
40.	Plan of Phase 3 features	59
41.	General view of the east end of stone wall (N0148) from the south	61
42.	East-facing elevation of stone and brick vaults	62
43.	Plan of all recorded brick flues	63
44.	Flues (D0192) and (D0194) taken from the north	64
45.	Detail of damper system (K0542) from the north	64
46.	Section through flue (K0547) showing the heat-affected bricks	65
47.	Plan of double furnace room	66
48.	Stone wall (J0160) at the base of the east wall of furnace room	67
49.	Phase 3 features overlain with features on 1852 Ordnance Survey plan	68
50.	General view of the chimney area (K0228)	69
51.	Detail of small retort furnace (K0006)–(K0010) from the north	70
52.	Machine mounting bases (N0248)	71
53.	Wall (N0135) from the south-east	72
54.	Brick well (J0310) from the north	72
55.	Plan of Phase 4 features	74
56.	Phase 4 features overlain with features of detailed 1915 plan	75
57.	Elevations of double furnace room	76
58.	East elevation of two furnaces (J0045) and (J0046)	77
59.	General view of brick base (J0050) from the south	79
60.	General view of retort benches from the south	79
61.	Section through retort furnace	79
62.	Front elevation of retort furnace	80
63.	Detail of one of the furnace ovens showing the sloped base	81
64.	Detail of the top of one of the furnaces from the west	82
65.	Detail of a clay retort	82
66.	View through the central flue running through the retort benches	83
67.	View of north overhead flue (C0026) from the west	84
68.	View of the lower flue and support (C0027) from the north-east	85
69.	View of the rail tracks to the east of the retort benches	86
70.	Engine mounting (J0007) from the west	87
71.	Cobbles (J0248) and (J0249) abutting chimney base (J0240)	87
72.	General view of the main flues at south end of Gasworks	88
73.	Section through flues (J0312) and (J0313) as they join from the north	88
74.	Brick base (K0089) from the north	89
75.	General view of Area K from the south-west	90
76.	Brick cells at south end of Area K	91
77.	Brick and cement bases (K0360)–(K0363)	92
78.	Brick-lined channels to the north of the circular bases	92
79.	General view of the lift shaft and corridor (N0154) from the west	93
80.	Channel and chamber microstructure Unit 1	96
81.	Probable charred peat fragment with yellow clay staining to voids	97
82.	Vesicular melted charred materials – possible coal	99
83.	Moulded architectural plasterwork, SF100 and SF101	104
84.	Retort bench with eight retorts, Fakenham Gas Works	105
85.	Drawing horizontal retorts, South Metropolitan Gasworks, <i>c</i> late 19th century	106
86.	Examples of ceramic retorts (after Hornby 1911)	107

87.	Ceramic retorts at the abandoned gasworks site at Shaw Lodge Mill, Halifax	107
88.	Intact fireclay retort	108
89.	Flange of retort stamped 'GLENBOIG'	109
90.	Late 12th/13th-century medieval body sherds, (P0004) and (P0005)	112
91.	Probable 16th-century sherds, SF41, (K0316)	112
92.	Various medieval and post-medieval ceramics: (a) tin-glazed earthenware, TP5/A; (b) imported Ch'ien Lung teapot cover, Layer 008, Area H; (c) decorated SPMRW sherd, SF10, TP7/C; (d) SPMOW platter rim, SF11, TP6/A; (e) decorated SPMRW sherd, SF15, TP6/B	114
93.	Imported Ch'ien Lung teapot cover, Layer 008, Area H	115
94.	Hammer-head rim sherd from Wesser dish or bowl, SF7, TP5/B (north)	115
95.	German stoneware sherd from a moulded Westerwald-type biconic jug, SF11, TP6/A	115
96.	Tin-glazed earthenware sherd with a painted Chinese porcelain-inspired rim, SF3, TP5/A	116
97.	Selection of intact stoneware bottles from New Street Gasworks	116
98.	Transfer-printed plate base sherd, SF93.2 (N0105)	117
99.	Bisque porcelain figure of a boy, SF14 (K1000); H: 103.5mm	117
100.	Small porcelain coffee can, (P0003); H: 65.4mm	118
101.	Fragment of a Minton encaustic tile, SF6 (B0001)	118
102.	Conjoining sherds of a Craven Dunnill & Co Ltd encaustic tile, SF6 (B0001)	119
103.	Fragment of a moulded Craven Dunnill & Co Ltd fireplace tile, SF32 (Unstratified)	119
104.	Fragment of a late-19th-century Dutch tin-glazed earthenware tile, SF24 (K0000)	120
105.	Clay tobacco pipes of William Banks, <i>c</i> 17th century	121
106.	Clay tobacco pipes of Thomas Banks and William Young, <i>c</i> 17th century	122
107.	Clay tobacco pipes of Patrick Crawford, late 17th century	123
108.	Dutch-style clay tobacco pipes	124
109.	Spurred clay tobacco pipes	125
110.	Clay tobacco pipes of 19th-century date	126
111.	Clay tobacco pipes of 19th-century date	127
112.	Brass oil lamp fitting, Area FA2, Layer B	129
113.	Iron artefacts: (a) galvanised chimney stack, FA2, Layer B; (b) long iron tools, Area 1A, Vault 9	131
114.	Architectural ironwork and iron tools: (a) decorative wall-mounted bracket, SF22 (K0000); (b) fretted vent cover, (K0000); (c) roof finial, Area 1A, Layer B; (d) large hand file, Area FA2, Layer B; (e) open-ended spanner, SF76 (N0085)	132
115.	Wrought iron decorative gate or fence panel, SF23 (K0000)	133
116.	Iron fittings: (a) T-shaped bolt, Area FA3, Layer B; (b) iron nails, (J0121)	135
117.	Iron retort inspection box in situ within furnace wall	136
118.	Fretted vent cover, SF21a (K0000)	137
119.	Contemporary images of similar elongated tools to those found at New Street	138
120.	Shovel blade, SF8 (B0001)	139
121.	A selection of lead, copper alloy and worked bone artefacts: (a) possible rim counterweight, SF81.5 (unstratified between (N0501) and (N0502)); (b) lead nail, Vault 9; (c) lead nail, Vault 9; (d) copper finger ring, Area N; (e) brass oil lamp component, Area FA2, Layer B; (f) bone handle, SF5, TP4/A (north); (g) bone knife handle, (P0004); (h) bone knife handle, SF79 (N0085)	142
122.	Selection of intact 19th- and early-20th-century glass bottles	143
123.	Corrosive vitrified residue build-up in the interior of working retort at Biggar Gasworks Museum	145

124.	Leather shoe fragments: (a) quarters and lining of ankle boots with central fastening, SF17, Cat 5; (b) upper of boot with central lacing and manufacturer's stamp, SF17, Cat 12; (c) latchet of shoe or boot, SF17, Cat 10; (d) vamp, Cat 15; (e) quarters, Cat 15; (f) infant's left shoe, SF77, Cat 4; (g) vamp and quarters fragment, Cat 18; (h) sole and quarters fragment, Cat 18; (i) boot with central fastening, SF17, Cat 13; (j) right boot with central fastening, Cat 17	147
125.	Location of PA1(A) and PA1(B) archaeological works	157
126.	Plan of excavation area PA1(B)	158
127.	Extract from Edgar's map of 1765	158
128.	Extract from Kincaid's plan of 1784	159
129.	Extract from Kirkwood's map of 1817	159
130.	Extract from Ordnance Survey map, surveyed 1852 (Reproduced with the permission of the National Library of Scotland and under Creative Commons (CC BY 4.0))	160
131.	Remains of a stone well in Trench 2, PA1(A) area	161
132.	Plan of the PA1(B) excavation area	162
133.	Early stone-built fireplace (Context 8018), PA1(B) area	163
134.	Drain (8013) after excavation, PA1(B) area	163
135.	Stone-built sump (8029), PA1(B) area	164
136.	Detail of the range and fireplace, west-facing elevation	165
137.	Worked bone tools from PA1(B), SF2a, (8012)	168

LIST OF TABLES

1.	Properties of architectural mouldings, SF100 and SF101	103
----	--	-----

1. ABSTRACT

An extensive programme of archaeological fieldwork between August 2006 and May 2008 in the area of the former New Street Gasworks and New Street Bus Depot, Canongate, Edinburgh revealed remains of one of the earliest and most significant gasworks in Britain. As well as patches of medieval and post-medieval backland soils and post-medieval structures that pre-dated the establishment of the New Street works in the first quarter of the 19th century, substantial structural remains of the various phases of this industrial undertaking were recorded, along with a suite of associated artefacts.

These works have permitted the exploration of the industrial heritage of Edinburgh, as well as revealing important evidence of the medieval and post-medieval occupation of the Canongate. This is the first major excavation of an urban gasworks in Scotland and has enabled an examination of how these gasworks functioned and how they expanded with the introduction of more efficient systems and new technology.

2. INTRODUCTION

2.1 Overview

This report presents the results of an extensive programme of archaeological excavation and historic building recording undertaken by AOC Archaeology Group in the area of the former New Street Bus Depot (Canmore Site Number 191564) and the New Street Gasworks (Canmore Site Number 52212) to the north and south of Calton Road, Canongate, Edinburgh. These areas form the core of the prestigious New Waverley development site, formerly Caltongate, which is located within the World Heritage centre of Old Town Edinburgh.

The excavation works were designed to satisfy the requirements of the local planning authority, City of Edinburgh Council, who are advised on archaeological matters by the City of Edinburgh Council Archaeology Service. The excavation works were completed in accordance with the principles inherent in NPPG 5 (SOEnD 1994a), NPPG 18 (SODD 1999) and PAN 42 (SOEnD 1994b). The

fieldwork was sponsored by Mountgrange Ltd and the post-excavation analysis was funded by New Waverley Advisors Ltd.

The objective of the archaeological works was to fully excavate and record all the archaeological features revealed below the recently demolished New Street Bus Depot relating to the 19th-century New Street Gasworks and any earlier features. The works were carried out between August 2006 and May 2008. The excavations followed on from a previous evaluation (test trenching) of the site undertaken in 2000 (Gooder 2000), the results of which led to the requirement of the full excavation of the site by the City of Edinburgh Council.

The excavations revealed substantial surviving remains of brick and sandstone walls and gasworks ephemera surviving to depths of 4m below layers of overburden, which relate to the known 19th-century New Street Gasworks. Buried garden soils of medieval and post-medieval date were also recorded beneath these remains, revealing important evidence of the medieval and post-medieval occupation of the Canongate. Three major phases of Gasworks

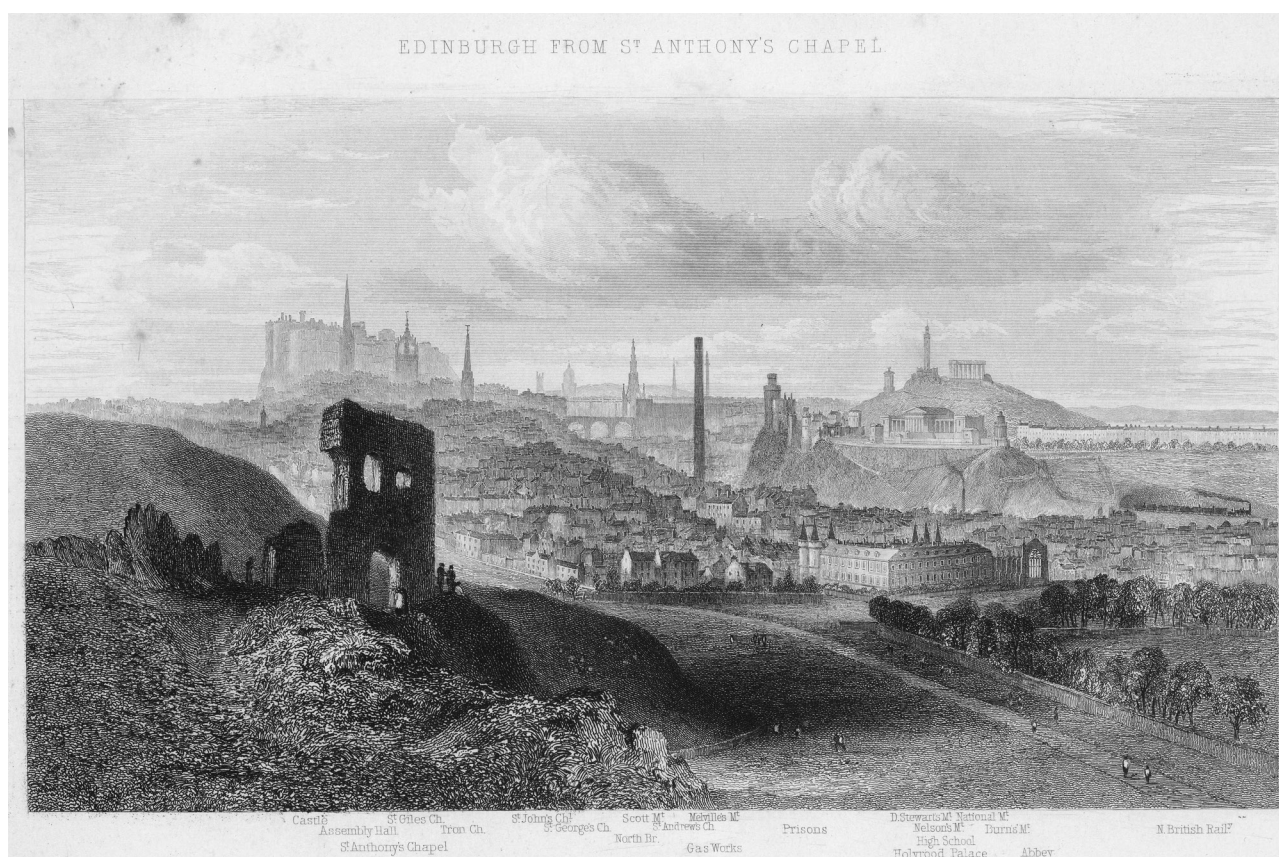

Illus 1 Early engraving of the City of Edinburgh: vista from St Anthony's Chapel showing the New Street Gasworks chimney at the centre (© HES)

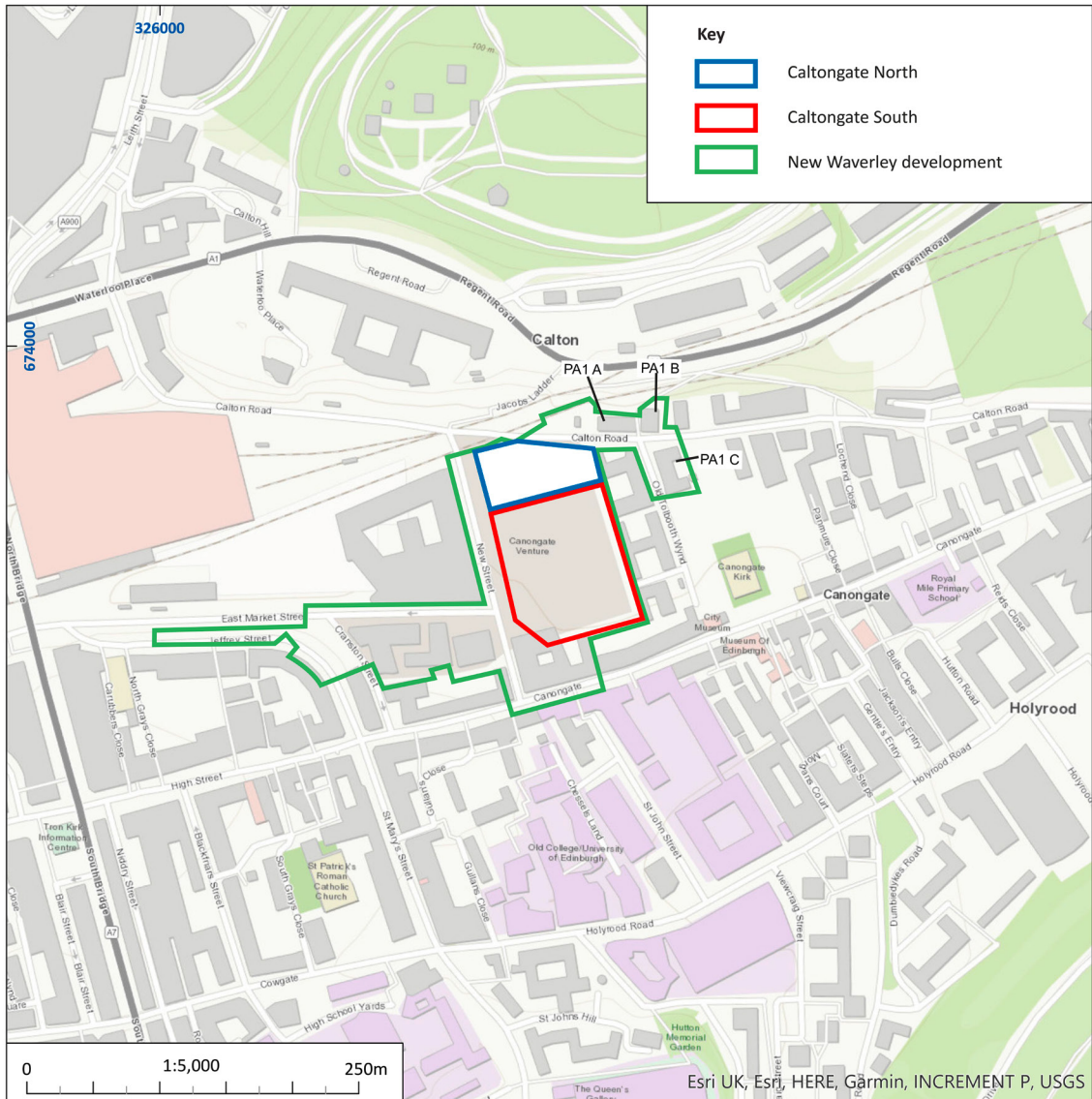
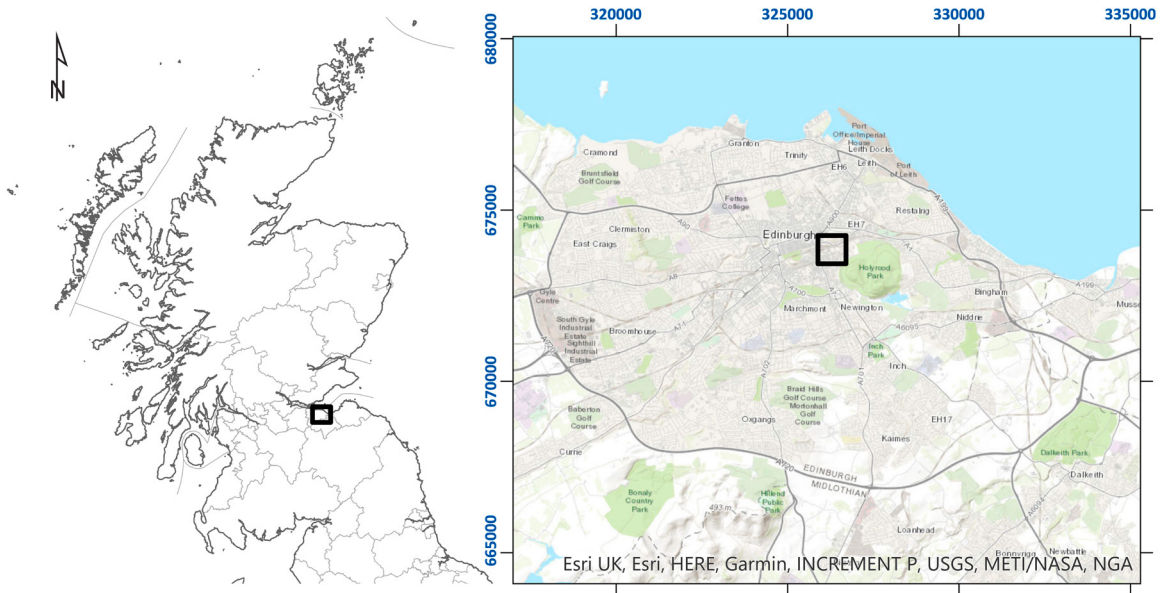

Illus 2 Location of Caltongate South, Caltongate North, PA1(A) and PA1(B)

construction were recognised, which could, in the main, be matched to the surviving cartographic and photographic records.

The excavations provided the opportunity to reveal a significant industrial site as well as being the first major fieldwork investigation of an urban gasworks in Scotland. It has enabled an examination of how these gasworks functioned and expanded with the introduction of more efficient systems and new technology. The lighting of the city with coal gas was at the forefront of the industrial revolution taking place at the beginning of the 19th century and represents an industry of pivotal importance in the modern development of Edinburgh as well as a key site that illustrates Scotland's industrial heritage (Illus 1). Both Edinburgh and Glasgow were the locations of Scotland's first commercial gas companies, begun in 1817, several years before the next gasworks ventures in Scotland, including one at Leith which was set up from 1822 onwards (Cotterill 1976: 121).

2.2 Location

The archaeological works at the former New Street Bus Depot and earlier Gasworks covered an extensive area within the World Heritage Site of Edinburgh's Old Town, with New Street to the west, the rear of buildings fronting the north side of Canongate to the south and Calton Road to the north (Illus 2). The archaeological works were undertaken in two distinct phases, with the majority of the site located to the south and centre (0.405ha) excavated in 2006 and 2007 (NGR: NT2630 7385), and another phase to the north (0.45ha) excavated between October 2007 and May 2008 (NGR: NT2626 7390). Prior to the archaeological works, a layer of concrete slab

floor pertaining to the former bus depot covered most of the site, which was bounded by brick walls associated with it. Beneath this were layers of rubble from the demolition of the New Street Gasworks, which was largely removed in the early 20th century. Beneath the demolition rubble was the extensive sub-surface remains of the New Street Gasworks (Illus 2 & 28). These two New Waverley sites, North and South, covered a large extent of the footprint of the New Street Gasworks and the results of these works will be reported together.

In April and May 2008 archaeological works were also undertaken in two areas to the south of Calton Hill, Edinburgh: PA1(A) and PA1(B) (Wilson 2008b; 2008c). Associated with this work was a programme of historic building recording of the surrounding structures (Sproat 2008). The PA1(A) and (B) sites will be considered together in Appendix 1. Further works associated with the New Waverley development on East Market Street (to the west) and on the corner of Old Tolbooth Wynd and Calton Road (to the east) are reported elsewhere (Lowther 2018; Engl forthcoming).

2.3 Geology

The superficial deposits in much of the area south of Calton Hill comprise Devensian–Diamicton till formed up to 11.8 million years ago in the Quaternary period and the local environment was previously dominated by ice age conditions (BGS Geology Viewer). In the area formerly covered by the New Street Gasworks, the bedrock is commonly sandstone of the Ballagan Formation, sedimentary bedrock formed between 345 and 359 million years ago, again in the Carboniferous period (BGS Geology Viewer).

3. THE HISTORY OF CANONGATE AND THE NEW STREET GASWORKS

3.1 Before the burgh (c 8000 BC–AD 1128)

Sporadic activity from the Mesolithic to the Bronze Age was found at the New Parliament site to the east of the Caltongate site (Carter et al 2008), while there is also evidence for the survival of late prehistoric and Roman archaeology at Edinburgh Castle on the strategic castle rock to the west (Driscoll & Yeoman 1997). An Early Bronze Age flat axe was discovered at 183–187 Canongate, Bibleland, on the north side of the Canongate, south of the former gasworks site (Canmore ID 52133; Coles 1969: 83). A bronze coin of the reign of Augustus was found embedded in a ball of clay during excavations at Moray House (Canmore ID 52313; Macdonald 1924: 328) to the south of the Canongate.

3.2 The medieval burgh (AD 1128–c 1560)

The Canongate, located east of Edinburgh, was bestowed burgh status, to support Holyrood Abbey, during the reign of David I, possibly as early as 1128 (Dennison 2008: 59). The Canongate represents the linear development of settlement along the road leading east from Edinburgh Castle towards Holyrood Abbey and the Palace of Holyroodhouse. Burgage plots extended north and south from this thoroughfare, and to the rear of the backlands of these plots were the two back lanes, called the Strands, one to the north and one to the south (Dennison 2005: 11). To the north was the North Back of Canongate (now Calton Road) and to the south was the South Back of Canongate (now Holyrood Road) which can be identified clearly on Kincaid’s map of 1784 (Illus 3). The North Back of Canongate was a route favoured by royalty in travelling from Holyrood Palace to the city. An

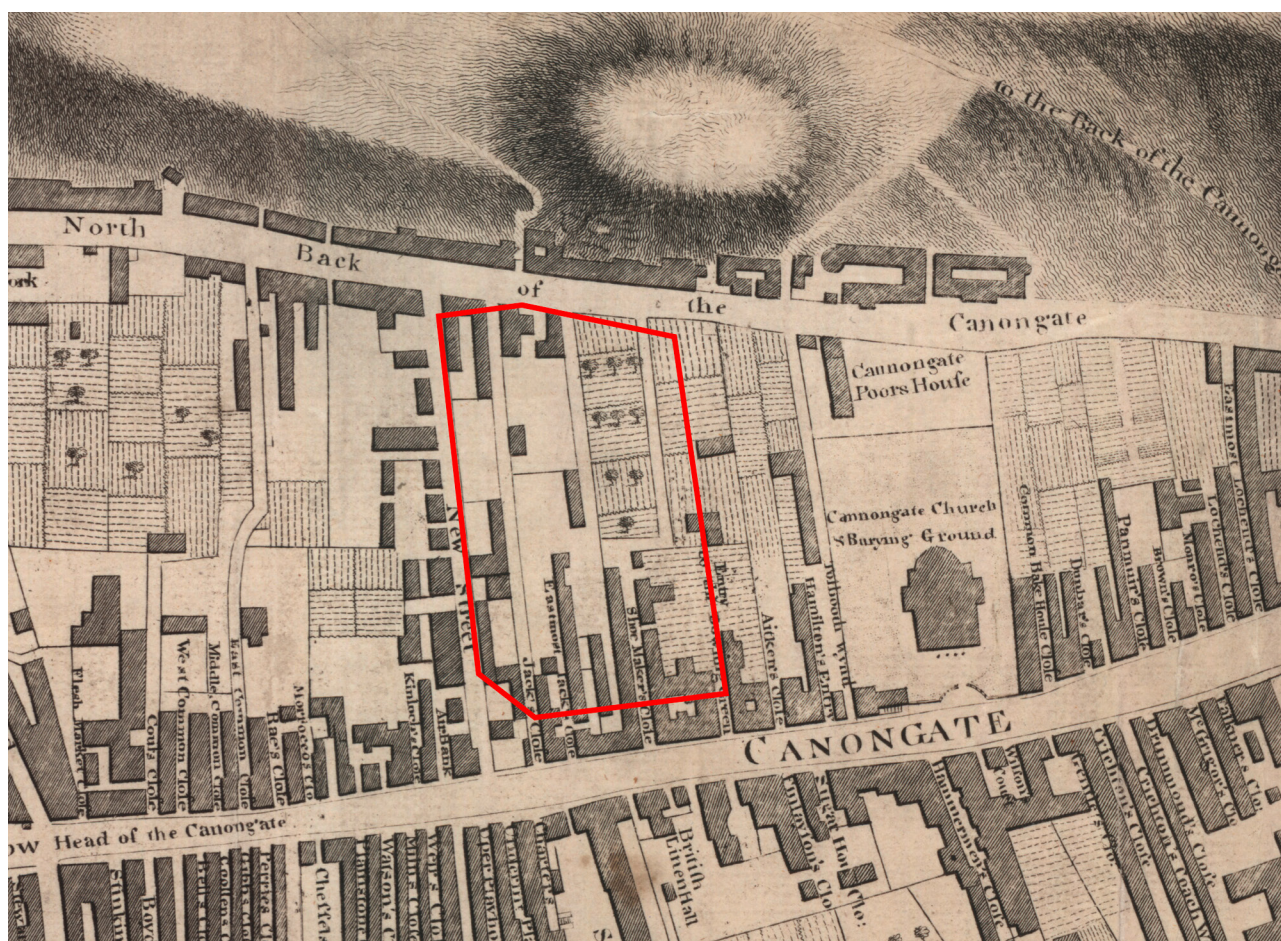

Illus 3 Detail from Alexander Kincaid’s 1784 *Plan of the City and Suburbs of Edinburgh* (Reproduced with the permission of the National Library of Scotland and under Creative Commons (CC BY 4.0))

Act of James VI called for it to be rendered and maintained as a thoroughfare suitable for royal passage (MacKay 1879: 115–16).

While the New Street Gasworks and other post-medieval and modern developments have caused major alterations to the Canongate Burgh area, much of its traditional herringbone street pattern layout remains (Adamson et al 2016: 6). There were ‘many traditional trades ... established in the area, including brewers, masons and tailors [and] ... trades such as shoemakers, tailors, weavers and hatters, along with stablers and coachmakers [who were] established to service the merchants and resident population of the burgh, and also to trade outwith the burgh boundaries, especially with the adjoining burgh of Edinburgh. Grocers, bakers, brewers and vintners also established themselves in the area, to feed and water the population’ (ibid: 10, 38). The various craftspeople sometimes worked in the backlands of their properties, ‘... using the sources of water at the foot of their burgage plots’, these areas being occupied by ‘middens, wells, workshops, gardens and animals’. Meanwhile, the frontages of the properties on the Canongate often saw commercial use, as booths or brewhouses (Dennison 2005: 14).

On the frontage, the Canongate Tolbooth, a Category A Listed Building (Canmore ID 52527), is located to the south-east of the Gasworks on the Canongate. Although the present building was constructed by Sir Lewis Bellenden in 1591 (Historic Environment Scotland Designations Portal: Listed Building No. 27582), a Tolbooth is first mentioned as early as 1471 (Dennison 2008: 59); it was the administrative centre of the Canongate, serving as its courthouse, burgh jail and the town council chamber.

The medieval and post-medieval burgh was marked by the variety of its inhabitants, as ‘the south side of Canongate attracted a multitude of wealthier residents, with many of Scotland’s landed gentry building large townhouses with extensive gardens stretching down to the South Back of Canongate ... to be close to the Royal Court based at Holyrood Palace. Land to the north of Canongate was more densely packed, with the lower classes filling the tenements fronting onto the street, and also squeezed into the backlands down to North Back of Canongate’ (Adamson et al 2016: 10).

Pottery dated as early as the 12th century was recovered during an earlier evaluation of the New Street Gasworks site (Gooder 2000), while pottery dated to the 14th century has been recovered from Canongate Churchyard to the east of the Gasworks (Canmore ID 52463; Simpson et al 1981: 58). To the south, at 146 Canongate, Huntly House, excavations in 1988 identified a large pit with pottery sherds dating to around the 13th century (Holmes 1987). Deposits from 22 Calton Road (Jones & Holden 2003) to the east of the Gasworks contained 13th- to 15th-century garden deposits and soils, while nearby the excavations at Canongate Poorhouse (Engl forthcoming) confirmed the extent of the medieval ‘backlands’ north of the Canongate.

3.3 Post-medieval Canongate (AD c 1560–1900)

Through the 16th and 17th centuries important nobles established houses along the Canongate (Dennison 2005: 76). However, while many of these were associated with large gardens, giving much of the Canongate a rural aspect, there was some evidence for backlands repletion, marked by ‘the emergence of closes giving access to the properties to the rear of the forelands’ (ibid). Pre-Ordnance Survey maps of the Canongate area can give some idea of the nature (and in particular the density) of settlement. One of the earliest depictions of the Canongate appears on *Edenburghum Scotiae Metropolis* in 1582 by Braun and Hogenberg (not illustrated), which depicts a profusion of buildings fronting on the Canongate and occasional buildings in the backlands on the north side of the Canongate.

James Gordon of Rothiemay’s map of 1647 (Illus 4) shows the built-up frontage of the Canongate with largely undeveloped gardens behind, with only occasional buildings in the backlands, for example along the western side of Tolbooth Wynd (now known as Old Tolbooth Wynd). A wall is shown to bound the northern limit of these backlands, with closes linking the North Back with the Canongate. No buildings appear to have encroached within the area which was to later become the New Street Gasworks behind the busy Canongate frontage, with the possible exception of the aforementioned buildings along the western side of Tolbooth Wynd, and a building on the north wall at the northern end of Tolbooth Wynd.

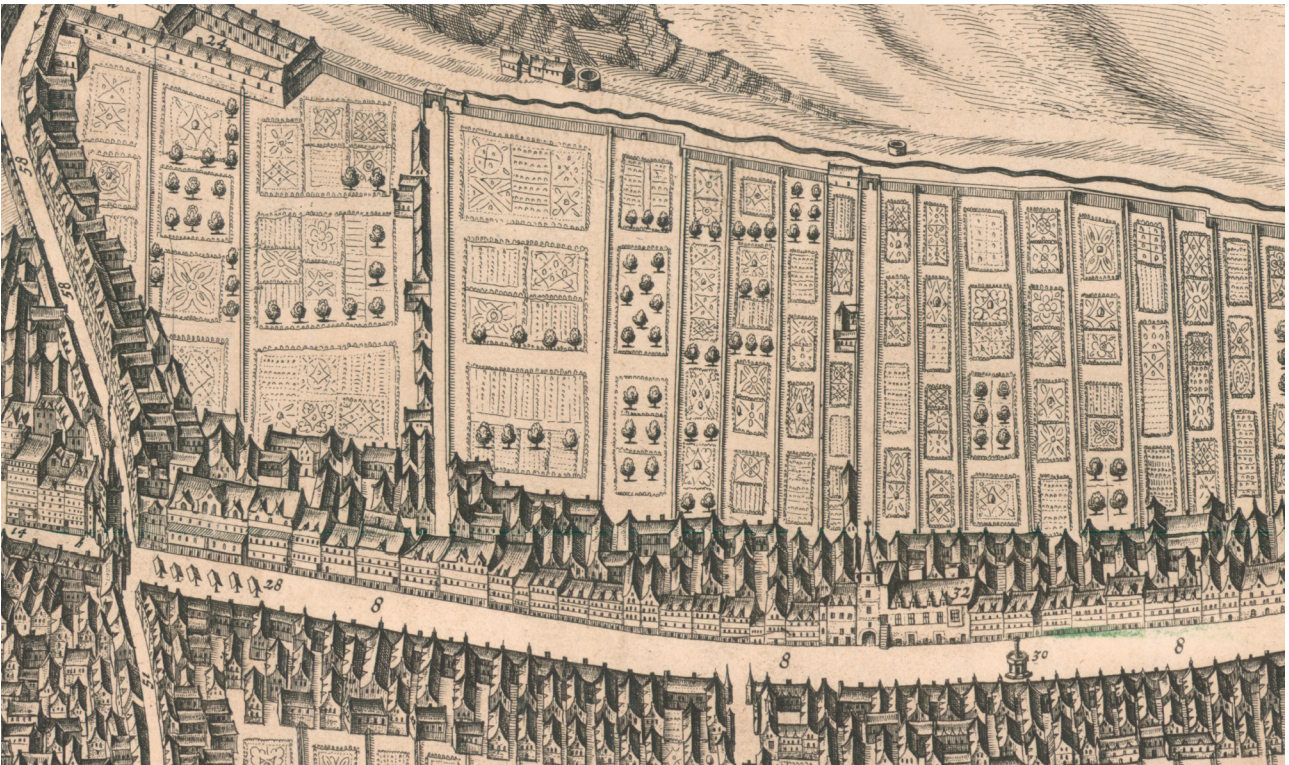

Illus 4 Detail from 1647 *Bird's Eye View of Edinburgh in 1647* by James Gordon of Rothiemay, Edinburgh: W & A K Johnston (published c 1870) (Reproduced with the permission of the National Library of Scotland and under Creative Commons (CC BY 4.0))

Rothiemay's map identifies the relatively less dense occupation of the burgh of Canongate in comparison to Edinburgh at this time, as 'Canongate was far more open, with much of the land behind the main street frontages ... used for semi-agricultural purposes' (Adamson et al 2016: 12).

Several other early maps show the largely undeveloped nature of the Canongate backlands until the late 18th century, with the backlands 'utilised to grow food for the residents (north side), or as ornamental gardens for the wealthier landowners in the burgh (south side)' (Adamson et al 2016: 38). The lack of depicted industrial sites is notable although 'John Ainslie's map of 1780 ... does show Chessel's Court being used as an Excise Office, indicating that ... a substantial amount of trade was crossing the burgh boundary' (ibid). However, this lack of visible large-scale industrial sites belies the extent of craft and trade activities that took place in the area in this period. Dennison suggests that in the 17th century '... the craftsmen of Canongate continued to outnumber merchants since the burgh now functioned very much as a manufacturing suburb of Edinburgh' (Dennison 2005: 98).

Of particular interest in understanding the trades practised on the Canongate to the south of the future gasworks site at this time is the presence of the Category B Listed 195 and 197 Canongate, Shoemakers' Land (HESDP: Listed Building No. 28437). According to Adamson et al (2016: 91), 'the stretch from 185 to 197 Canongate has long associations with the Incorporation of Cordiners (shoemakers). The 17th century tenement at 195–7 Canongate, known as Shoemakers' Land, was rebuilt and added to in 1725 by the Incorporation'. This represents much of the Canongate frontage just south of where the New Street Gasworks would later be built. Nearby, the Category B Listed Bible Land, 183–187 (Odd Numbers) Canongate, Edinburgh (HESDP: Listed Building No. 28434) 'was built for the Incorporation of Cordiners in 1677' and has a 'pedimented cartouche, dated 1677, [which] depicts the Cordiners' emblem, the shoemakers' knife, flanked by cherubs' heads and an open book'.

The south side of the Canongate, in particular, was marked by a concentration of wealthy residents, attracted by proximity to the Parliament and the Royal Palace at Holyrood. However, with the Act of

Union of 1707 removing the Scottish Parliament, and the monarchy being absent from Scotland from the Civil War until 1822, such wealthy residents gradually moved away (Adamson et al 2016: 55). Between 1775 and 1790 the population of the Canongate rose from *c* 4,500 to *c* 6,200 and by this time the area contained a multitude of dwellings, both of the wealthy and the poor, the area being marked by an assortment of closes and the insertion of new streets, including New Street. First known as Young Street in the late 1700s, New Street was seen as a bold civic improvement scheme ‘designed to avoid the lack of privacy and squalor of the main street’ (ibid: 117).

Edgar’s 1765 map (Illus 5) shows several building lines extending northwards from the Canongate, expanding into the future Gasworks site from the south. While open ground, the map shows that cultivation plots still predominated in the north of the backlands, with occasional

buildings marked against the north wall, and structures within the future Gasworks site also include properties belonging to ‘*Mr Sims*’ and ‘*Mr Wisehart*’. New Street had been broken through to link the Canongate with the North Back by the time of Kincaid’s 1784 map (Illus 3). Cultivation and trees appear to be limited to the east side of the area between New Street and Tolbooth Wynd. Several closes running from the Canongate into the area where the Gasworks would be constructed are named on Kincaid’s map, including Shoe Maker’s Close, Jack’s Close, Eastmost Jack’s Close, Entry to the Bowling Green (Bowling Green Close) and Aitken’s Close.

In 1799, a Mr Dougal MacDougal, cowfeeder of Tolbooth Wynd, having bought land and several ‘old houses’ in Tolbooth Wynd from the heirs of Francis Montgomery, obtained a warrant from the Dean of Guild to erect a stone-built, three-storey tenement in the area. In the course of this development part

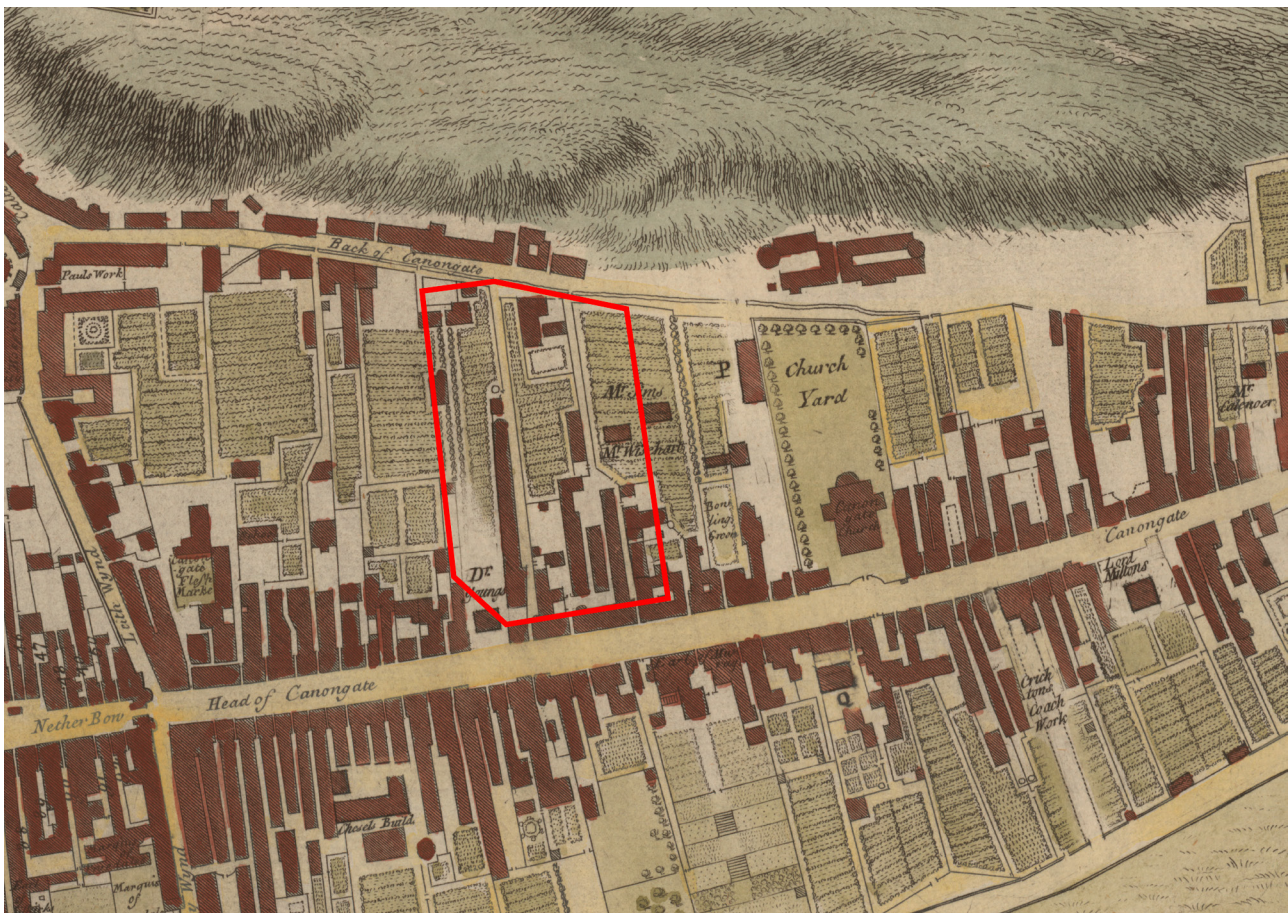

Illus 5 Detail from *Plan of the City and Castle of Edinburgh* by Willm Edgar architect anno 1765 (Reproduced with the permission of the National Library of Scotland and under Creative Commons (CC BY 4.0))

of an old tenement 'which was built with lath and plaster' was demolished (Edinburgh City Archives: Dean of Guild Court April 1799). It would seem, therefore, that up to this date some timber-built structures survived in this area of Edinburgh. Indeed, timber construction may have been prevalent in the initial spread of domestic buildings into the future Gasworks site during the early 18th century.

Robert Kirkwood's map of 1817 (Illus 6) depicts the area north of the Canongate, between New Street (to the west) and Tolbooth Wynd (to the east) just prior to the construction of the first buildings of the Gasworks and can be compared with James Kirkwood's 'New Plan' of 1821 which depicts a large building annotated as 'Gas Works' in the centre of the plot (Illus 7). The Canongate frontage is well

developed, and there are numerous buildings on the south side of the North Back of Canongate, although much of the area where the Gasworks would be constructed appears to be gardens, surrounding broadly spaced buildings in the centre of the area between the Canongate and the North Back, an area labelled 'The Property of Alex[ande]r Ramsay Esq[ui]r[e]' in Illus 6. This could be a descendant of the poet Allan Ramsay, whose daughter is known to have lived on New Street in the late 18th century (MacKay 1879: 123; Grant 1883: 18).

One of the buildings in this area, though unlabelled, can tentatively be identified as the former property of Mr Wischart, shown on Edgar's map a half century before, and imminently to be removed by the construction of one of the largest Gasworks

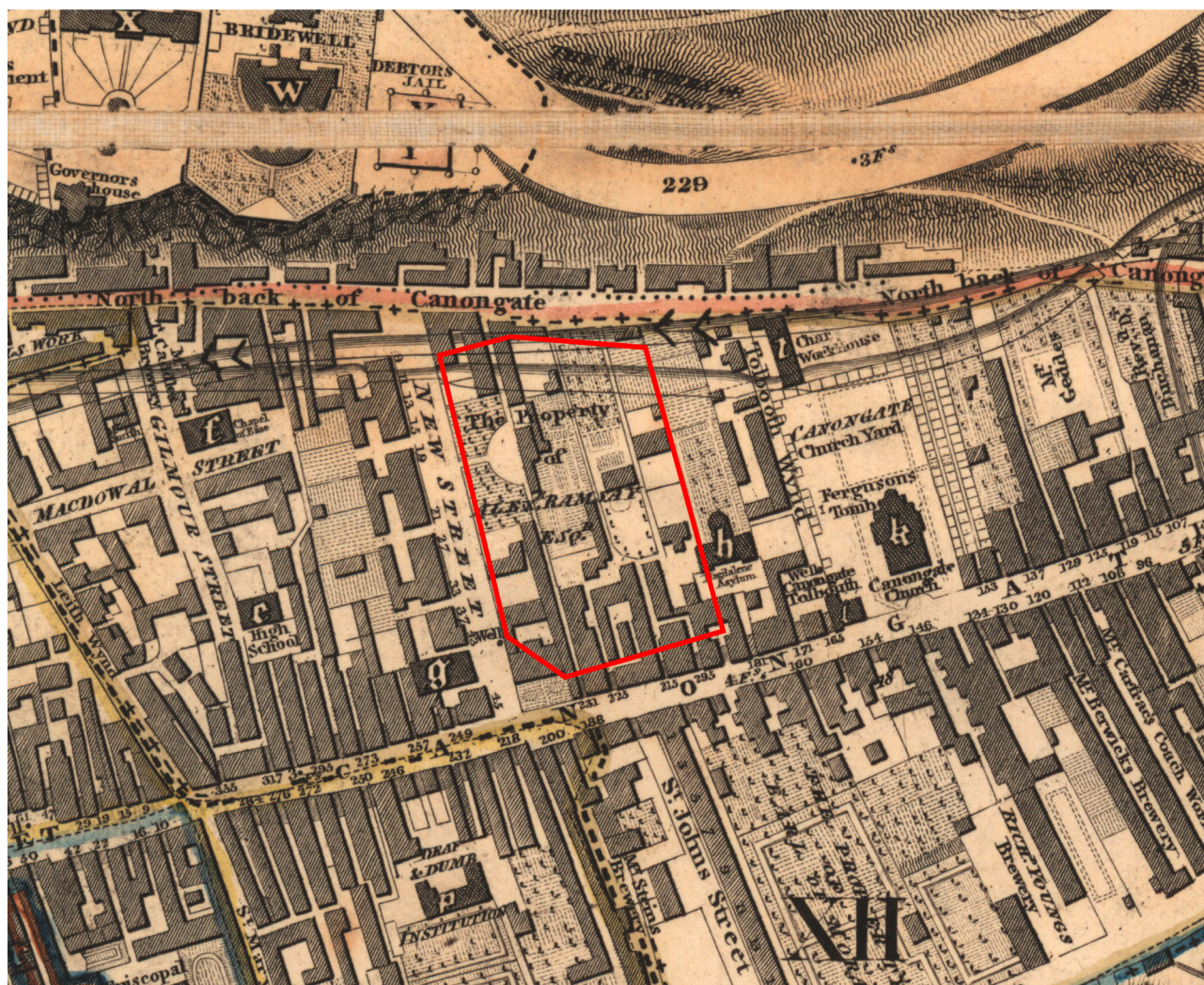

Illus 6 Detail from *This Plan of the City of Edinburgh and its Environs*, 1817. Edinburgh: Kirkwood & Son (Reproduced with the permission of the National Library of Scotland and under Creative Commons (CC BY 4.0))

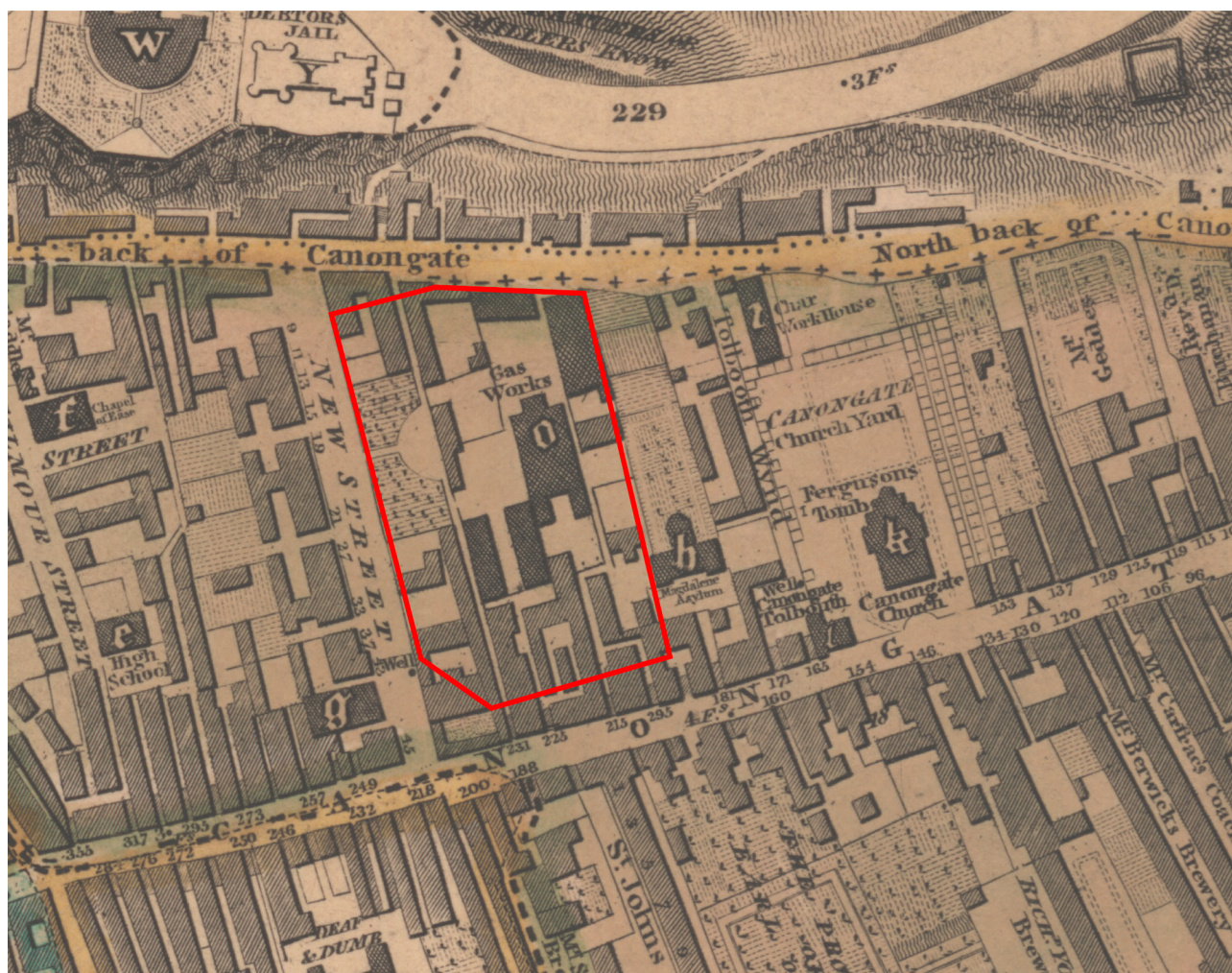

Illus 7 Detail from Kirkwood's *New Plan of the City of Edinburgh*, 1821 (Reproduced with the permission of the National Library of Scotland and under Creative Commons (CC BY 4.0))

buildings. The Kirkwood maps also provide early depictions of the Magdalene Asylum, recently built to the east of the area where the Gasworks would be constructed, and marked as an 'h' on Illus 7.

The loss of the Scottish Parliament and the absence of the monarchy in Scotland throughout the 18th century reduced the status of Canongate. This was exacerbated in the later 18th century by the building of the New Town and was further driven in 1817 by the opening of Regent Street 'along the foot of Calton Hill', which became the main route into Edinburgh from the east, in lieu of Canongate High Street (Dennison 2005: 130). The gradual departure of Canongate's wealthier residents in the later 18th and early 19th centuries perhaps facilitated, or at least permitted, the construction of industrial sites such as the Gasworks and the various Canongate

breweries. Pollution from the Gasworks was one reason for the movement of wealthier residents out of New Street and the wider Canongate area to the New Town.

The National Record of the Historic Environment records further post-medieval sites in the vicinity of the Gasworks and the western Canongate, several of which indicate the importance of the brewery industry in the late post-medieval period, as 'the "cottage-industry" style of brewhouses within tenements and their backlands expanded into commercial operations making use of underground springs ... accessed via a number of wells the length of the Canongate' (Adamson et al 2016: 39). A 17th-century tenement (later a brewery) is present at 124 Canongate (Canmore ID 52374) to the east of the Gasworks, while a 19th-century brewery

and tenement is located at 114–120 Canongate (Canmore ID 332344). Geology and water quality in the vicinity of Calton Hill suited the brewing industry, with the Drybrough or Dryburgh's brewery being set up around the North Back of Canongate in the 1780s (Adamson et al 2016: 144). A variety of maltings and brewery buildings were to be found at the foot of Calton Hill and north Canongate in the early 19th century (ibid: 145), including the Calton Hill Brewery. The expansion of the breweries in Canongate during the middle and late 19th century saw 'most sinking their own boreholes on site to tap into an uninterrupted and more easily controlled water supply, thus avoiding any contamination' (ibid: 39).

The coming of the North British Railway to Edinburgh in the mid-1840s boosted industrial activity in Canongate, permitting the easier importation of raw material and exportation of products. Industries established in the Canongate around that time included several in proximity to the Gasworks, most pertinently the Canongate Iron Foundry on Old Tolbooth Wynd. Other industries operating in the area included an aerated water works, various iron and brass foundries, the Holyrood Flint Glass Works, tanneries, a corn mill, a confectionery works and smithies. Adamson et al (2016: 156) also note the development of premises for storage of goods and raw material including 'several large timber yards ... in the north-western section of Canongate, and an associated cooperage ... probably manufacturing barrels for the nearby breweries'. As late as the 1890s the provision of transport for the import of raw materials and export of products for the New Street Gasworks (and the other gas-producing plants then active in Edinburgh) 'was confined to the North British Railway System' (Herring 1907: vi).

By the later 19th century, the burgh of Canongate had been joined with Edinburgh, with the passing of the Edinburgh Municipal Extension Act on 23 June 1856 (MacKay 1879: 22). Major urban improvements were undertaken following the Edinburgh City Improvement Act 1867, with tenements being improved and new streets created across the area (Adamson et al 2016: 17). However, Dennison records the poverty in housing of many of the area's inhabitants, as 'in 1861 the Canongate Registration District had 47 per cent of families in

one room dwellings' (Dennison 2005: 150) and even in the late 19th century the area was still marked by poverty in housing provision, as 'the Canongate ... was suffering from a lack of investment and severe overcrowding' (Adamson et al 2016: 20).

3.4 New Street and its vicinity

New Street, to the west of the Gasworks, originated as an improving development around 1760, when it was known as Young Street, providing access between Canongate and the North Back of Canongate. Several buildings were cleared for the insertion of New Street, including the mansions of the Earls of Angus and of Henry Kinloch, the latter 'a wealthy burgher of the Canongate in the days of Queen Mary' (Grant 1883: 18). Inhabitants of New Street in the 18th century included high-status individuals such as the eminent judge Henry Home, Lord Kames, who was one of the Lords of Session between 1752 and 1782; Sir David Dalrymple, Lord Hailes, a Lord of Session between 1766 and 1792; Lady Betty Anstruther, and Christian (or Jean) Ramsay, daughter of the poet Allan Ramsay, and Dr Thomas Young (MacKay 1879: 122–3; Grant 1883: 18). The last was 'a pioneering Professor of Midwifery at University of Edinburgh (1756–83)' for whom the street was likely originally named (Adamson et al 2016: 140); his detached house is visible at the south end of the street on Edgar's plan of 1765 (Illus 5). Lord Kames' house is marked on the Ordnance Survey map of 1854, surveyed in 1852 (Illus 8) on the east side of New Street, close to the Gasworks.

MacKay's description of New Street notes that 'the houses, as originally designed and occupied, consisted of self-contained dwellings of three and four flats and sunk areas ... tenanted by members of the aristocracy and the elite of the citizens' (MacKay 1879: 122). The street was 'a private one, with posts and chains, till declared a public one in 1786', though essentially it was only made public in 1819 'when power was reserved by the late Dr Thomas Young's representatives to make New Street a public access from the High Street of the Canongate to the road at the foot of Calton Hill' (Boog Watson 1923: 95). By the late 19th century the street was 'sorely faded and decayed' but it was still said to contain 'a series of semi-aristocratic, detached, and not

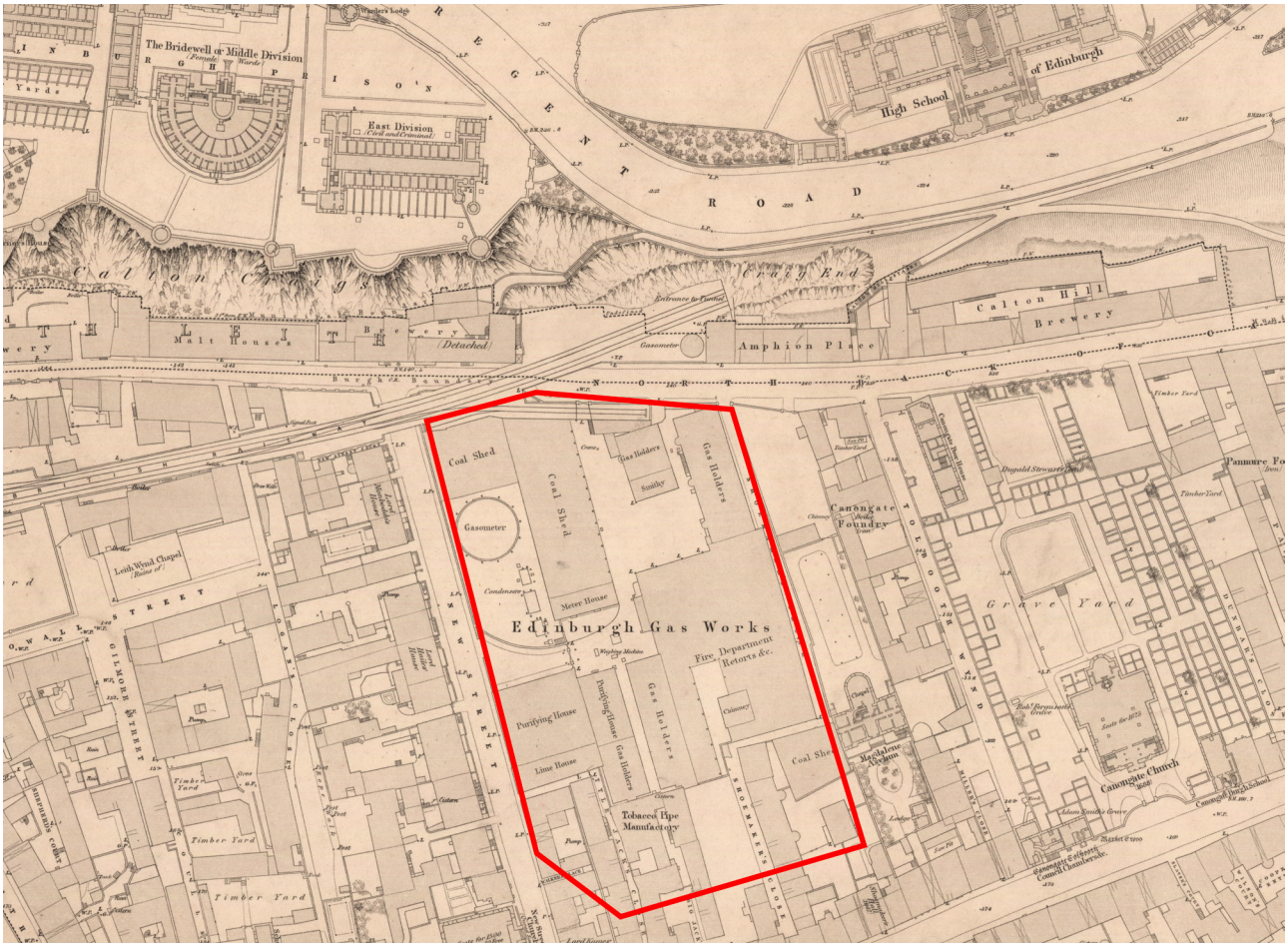

Illus 8 Ordnance Survey 1854 (Surveyed 1852) *Edinburgh* Sheet 30, scale 1:1056 (Reproduced with the permission of the National Library of Scotland and under Creative Commons (CC BY 4.0))

indigent mansions of the plain form peculiar to the time’ (Grant 1883: 18). MacKay notes that by 1879 ‘the houses in New Street are now divided into shops and separate flats, and what was a garden fronting the houses, is now occupied by the Edinburgh Gas Company Works’ (MacKay 1879: 124).

Old Tolbooth Wynd to the east of the Gasworks was another route from the high ground of the Canongate down towards Calton Road to the north. It ‘takes its name from the Tolbuith of the Canongate, the entrance to the close being a vaulted pend under the Tolbooth itself’ (Boog Watson 1923: 98).

The main entries to the north of the Canongate between New Street and Tolbooth Wynd were two closes: Little Jack’s Close (to the west) and Big Jack’s Close (to the east), both visible on historic mapping. ‘Jack’s Closs’ appears on Ainslie’s map of 1780 (not illustrated) between New Street and Shoemakers’ Close. Much later, the two Jack’s Closes are also marked on a ‘Plan showing site area

of Old Works and adjoining properties fronting Canongate 1915’ (Illus 9), made by the Edinburgh and Leith Corporation’s Gas Commissioners, which shows the New Street Gas Works in detail (HES EDD 747/1). According to Boog Watson, the close was:

known formerly as Mausie Smith’s Close. Massia or Mausey Smith was wife of Patrick Heart ... The subjects on the east side of New Street, sold by Dr Thomas Young to Henry Home, Lord Kaims, were bounded on the east by subjects belonging to the heirs of John Jack and the close called Mausey Smith’s Close or Jack’s Close (i.e. Little Jack’s Close; the ‘Big’ and ‘Little’ refer to the width of the entrances). Mausie Smith seems to have owned the property in her own right. The two closes take their names from Jack’s land, which lies between them; it was built

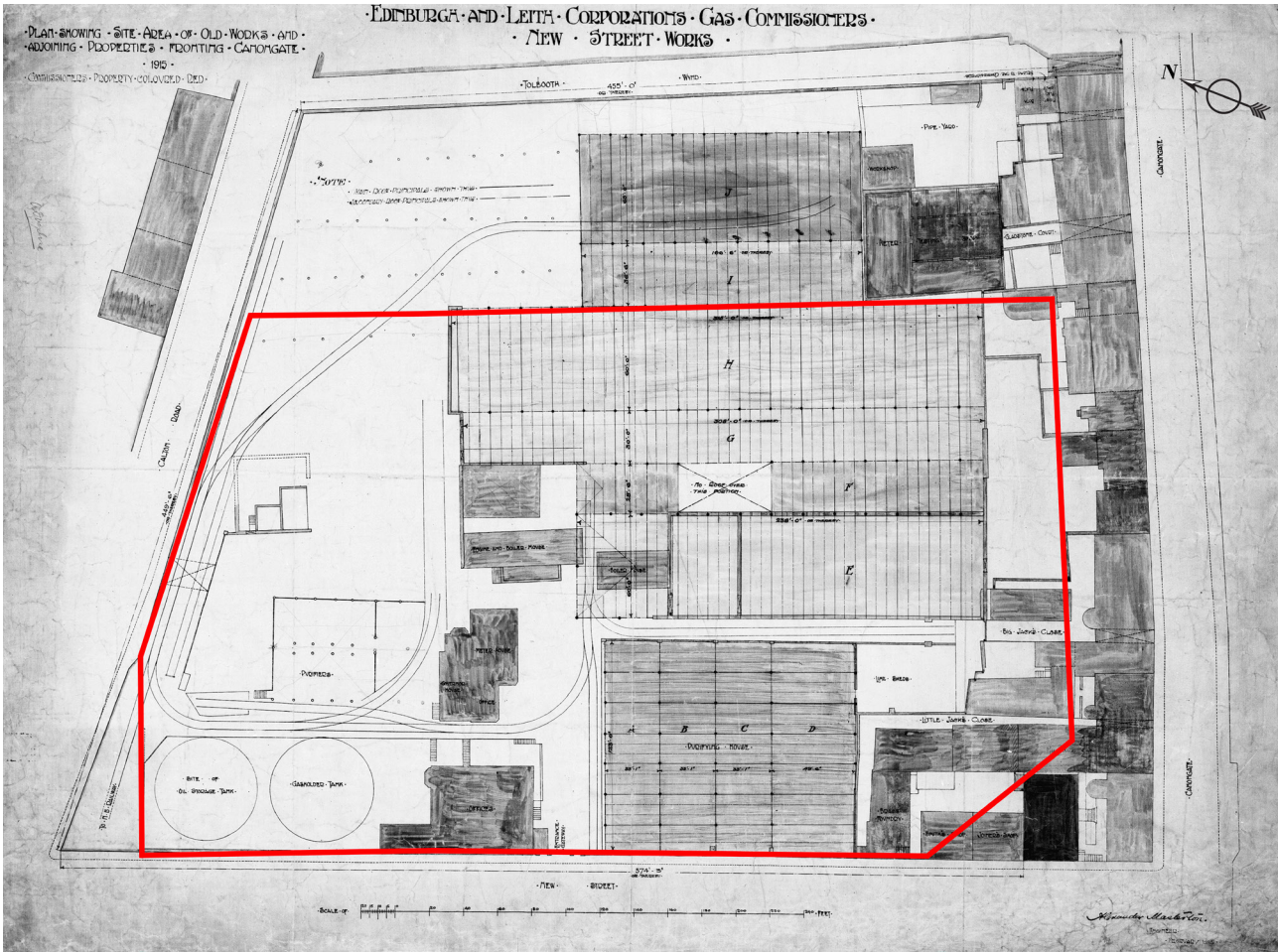

Illus 9 Edinburgh, New Street Gasworks Survey site plan, Alex Masterson, Engineer, Edinburgh and Leith Corporation's Gas Commissioners EDD 747/1 (© HES)

by Robert Jack, slater, and finished after his death by his brother John, also a slater. Robert had acquired part of the property from John Riddle, M.D., and his wife Jean Livingstone, on 10th May 1738, and partly from Robert Tod, senior, merchant in Edinburgh. John Jack was a captain ... a slater by trade, a bailie

of the Canongate, with property there and also in Edinburgh; he died before 27th July 1753 ... There are frequent references in the protocols to John Jack, tiler or slater, and his scattered properties ... Big Jack's Close was known also as Jack's Close or East Jack's Close. (Boog Watson 1923: 96-7)

4. THE NEW STREET GASWORKS AND EDINBURGH'S GAS INDUSTRY

4.1 An introduction to the development of the gas industry

Extensive archaeological works associated with the New Waverley development (which is described in 6 'The excavated evidence: New Street Gasworks' below) have recorded remains of the 19th-century New Street Gasworks, which supplied Edinburgh with fuel for gaslight, and later for cooking and heating, from 1817 to its closure around 1906.

4.1.1 Origins of the gas industry

The use of the word 'gas' to refer to flammable vapour is believed to have been coined by Jan Baptista van Helmont (1577–1644), a Flemish scientist who in 1609 discovered that 'a "wild spirit" escaped from heated coal and wood'. This he termed 'gas' from the Greek *chaos* (Peebles 1980: 7). Several people have been recorded as discovering combustible coal gas in the 17th century, including, in Britain, the Rev John Clayton of Wigan, who in 1684 lit gas collected from heated coal and described it as 'Spirit of Coals' (*ibid.*).

As early as the 1780s Archibald Cochrane, the ninth Earl of Dundonald, was using coal gas to light rooms in his house at Culross in Fife (Wood 1982: 1). The Ayrshire-born William Murdoch, while working for Matthew Boulton and James Watt, experimented with coal gas in Cornwall, lighting a room of his house in Redruth in 1792 before installing an experimental lighting system at the company's works in Birmingham in 1798 (Hunt 1907: 42–3, 49; Wood 1982: 2). Murdoch became known as 'the father of the gas industry', as he 'innovated various practical developments in making, purifying and storing gas from coal during his ... employment' (Peebles 1980: 8).

Early use of gas for lighting took the form of private supplies for individual buildings, rather than larger-scale public supply. In Britain, Boulton and Watt saw the potential for supplying cotton mills, installing lighting at the Manchester works of Phillips and Lee between 1806 and 1807 (Hunt 1907: 66; Wood 1982: 2). An article in *The Edinburgh Observer* in 1817 notes that around 1806,

... several attempts were made by private individuals to introduce the gas-lights into their shops in Glasgow and Edinburgh; but the method of separating the different ingredients obtained from coal in the process of distillation, and of purifying the gas to render it fit for burning without offensive smell, was then very imperfectly known, and consequently they were soon abandoned. (*Edinburgh Observer* 1817: 5)

Williams has described how gas lighting caused 'something of a social revolution' as 'by the middle of the nineteenth century ... city streets were brightly lit, making them safer and more conducive to social life at night. Theatres, concert halls, railway stations, and other public spaces too, knew a new brilliance' (Williams 1981: 33–4).

The idea for the use of coal gas for lighting public areas had come from the German, Friedrich Albrecht Winzer, who after changing his name to Frederick Albert Winsor, formed the Chartered Gas Light and Coke Company (also known as the London and Westminster Gas Light and Coke Company) in London in April 1812, the first public (municipal) suppliers of gas (Wood 1982: 2) and the first 'commercial gas enterprise' (Peebles 1980: 2, 10). The Gas Light and Coke Company, based at Great Peter Street in Westminster, began operating in 1813 (Thorsheim 2006: 138) when they built the first gasworks in the world, laid wooden pipes to carry the gas, and 'illuminated Westminster Bridge with gas lamps on New Year's Eve in 1813' (Peebles 1980: 10). Although the success of Winsor's 'splendid illumination' of the streets of Pall Mall was lauded in Edinburgh as a 'first brilliant display of gas-lights in the metropolis' (*Edinburgh Observer* 1817: 5), the success of his company depended on his chief engineer, Samuel Clegg. By 1815 the company had laid 26 miles of gas pipe through London (Wood 1982: 2). Clegg was one of the great early innovators of this industry as he had in 1805 erected 'a gas apparatus in the cotton mill of Henry Lodge, Esq., near Halifax', and had used lime in an attempt to purify gas the next year (Hunt 1907: 70). Clegg was also the designer of 'the horizontal rotary retort in 1817' (Peebles 1980: 10).

4.1.2 Growth and decline of the gas industry: from gaslight to electricity

In the early 19th century, domestic demand for gaslight 'proved far greater in Scotland than in England' (Cotterill 1980: 19), no doubt due to the relatively longer winter nights. Gas was used widely in private dwelling houses earlier than in English cities, with relatively little use of gas in 'the better class of houses' in London and other English towns for this purpose even as late as 1874, perhaps also due in part to 'the far higher purity of Scottish gas' (Cotterill 1976: 1218–19).

The world's first gas cooker was invented by James Sharp as early as 1826 (Peebles 1980: 11). However, while there were early examples of the use of gas for heating and cooking, and the public became more aware of the use of gas for these purposes from 1840 onwards, very few could afford to use gas fuel in this way (Cotterill 1976: 1278). Alexander Graham of Glasgow's Eagle Hotel produced the only popular Scottish gas cooker of the 1850s–60s (*ibid.*). The growth in the use of gas for purposes other than lighting, including cooking and heating, began in earnest in Britain around the late 1870s with the emergence of competition from electricity (Thorsheim 2006: 147). Cotterill notes that 'special gas rates for stoves became a normal procedure for encouraging their use by the end of 1884 in small and medium size companies' but less so at 'the largest undertakings at Glasgow and Edinburgh, which had less fear of rapidly losing their markets to electricity' (Cotterill 1976: 1287).

Peebles notes that gas-powered 'water heaters, room heaters and many other ancillary appliances such as soldering irons and hair-curling tongs appeared on the scene in the mid to late 1850s' while in 1855 Robert Wilhelm von Bunsen invented the atmospheric burner that bears his name, permitting the use of gas 'as a fuel for a whole variety of industrial and other applications' (Peebles 1980: 11). The use of gas in smaller-scale industrial roles is noted by Cotterill, although 'Scottish "town gas" was not widely used for heat in large-scale industrial processes during the nineteenth century' (Cotterill 1976: 1308–9). He notes, however, that 'on a small scale, gas blowpipes, soldering-iron heaters, crucible heaters and annealing furnaces were widely used by 1850' and 'even a town like Edinburgh with

only light industry, in 1911 used gas for branding, linotype bronzing and laundry machines, kilns, coffee-roasters, tailors', upholsterers' and laundry irons, enamelling and drying stoves and gas-heaters' (*ibid.*). Williams states that in the later 19th century 'the gas engine provided industry with a power unit small enough to be used to drive industrial machines, or small groups of machines' (Williams 1981: 38).

The introduction of the electric dynamo in the 1870s presented the first real threat of competition to the gas industry. The main role of gas was in lighting and, prior to the cheap availability of high-quality incandescent gaslight mantles for street lighting around 1895, illumination by gas used burners that were generally quite inefficient, and gave a variable quality of light (Peebles 1980: 11). In 1881 electric lighting was introduced experimentally in Edinburgh and in 1895 the city's first electric power station was established at Dewar Place (Shakhmatova et al 2012: 24). Despite this, the decline of the coal gas industry was a prolonged event with the last gas lamp in Edinburgh being turned off on 21 April 1965 in Ramsay Garden (*ibid.*: 23). Indeed, on the opening of the Granton Gasworks, which would ultimately supersede the New Street works, in 1903, the health of the coal gas industry was noted in the 'face of the evident progress of the Electrical Industry' (Herring 1903: 5). The introduction of incandescent burners was a boon to the gas industry, enabling 'Scottish gas undertakings ... to compete successfully with electricity for lighting, and to foster a rapidly expanding market for domestic cooking and space heating' (Cotterill 1976: 1315).

4.2 The techniques and technology of early gas production

Mike Roy, incorporating research by Ian West

The last surviving (though no longer operational) town gasworks in Scotland is Biggar Gasworks, and there the various elements of a late-19th-century/20th-century gasworks can be seen, albeit on a significantly smaller scale than the New Street Gasworks. This includes elements such as the coal store, retort house, chimney and gasholders, as well as the extensive apparatus associated with the cleaning of the gas and removal of by-products.

In the condenser pipes ‘the gas-tar mixture was cooled and most of its tar removed’; the exhauster ‘pumped gas through the scrubber (or filter system) to remove the rest of the tar and ammonia’, while the purifiers used ‘powdered iron oxide ... to remove toxic hydrogen sulphide from the gas’ (Historic Environment Scotland 2017).

In the early 19th century, the coal gas produced for the supply of towns across Britain was referred to as ‘town gas’. It was produced by heating coal in a closed tubular vessel, known as a retort, usually closed at one end and fitted with a door at the other. These were originally made of cast iron and were later manufactured with more heat-resistant fireclay and silica (Wood 1982: 4). The retorts provided an oxygen-free atmosphere and were heated by a furnace, and when several retorts were heated by the

same furnace these retorts became a ‘retort bench’ (Illus 10; Sproat 2006: 33).

The heated coal gave off a complex mixture of gases, mainly hydrogen, methane and carbon monoxide, and various impurities. The residue left behind after the gas was given off was coke, which was used to heat the retorts or sold as fuel. From the outset, it was realised that it was inefficient and impractical to attempt to manufacture gas at the rate at which it was required to be used and so gasholders were used to store gas for use at peak periods. Illus 11 is a schematic representation of a simple gasworks.

The carbonisation of coal at high temperatures produced ‘inflammable air or carburetted hydrogen, which is the primary object of the process, and by the combustion of which the light is supplied’



Illus 10 New Street Gasworks retort bench prior to demolition (© HES)

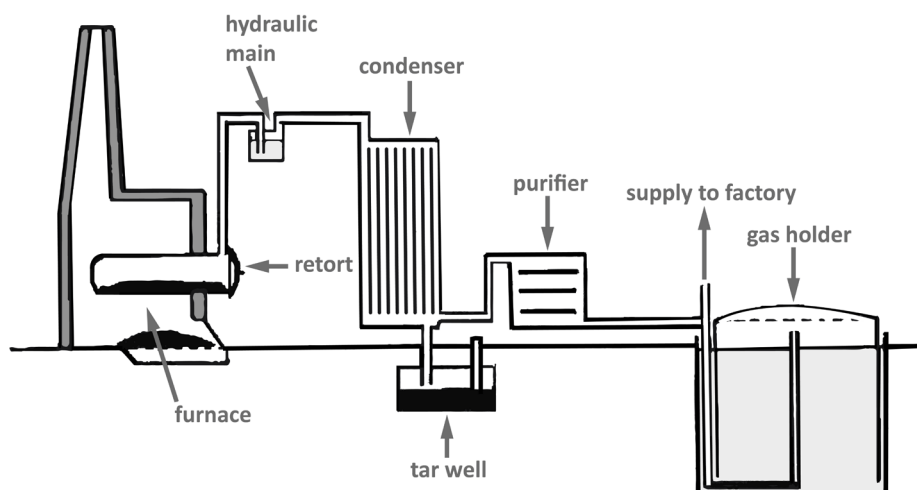

Illus 11 Schematic diagram of a simple gasworks process

(Edinburgh Observer 1817: 27). ‘Despite becoming red-hot, the coal did not burn, because the retorts were tightly sealed to keep out oxygen. Instead, the extreme temperatures forced virtually all of the volatile constituents from the coal’ (Thorsheim 2006: 137). The useful fuel gases produced included hydrogen, carbon monoxide and methane, while tar, sulphur compounds and ammonia were also produced as by-products (Wood 1982: 4). The ‘gases [were] driven off into a hydraulic main ... then purified, by-products removed and sold on, the gas stored in a holder, metered and distributed’ (Adamson et al 2016: 189). The hydraulic main provided a water-lute, effectively a seal, so that gas was distributed from the retorts under water and ‘could not blow back as an explosive mixture as the retorts were opened for charging with coal’ (Cotterill 1980: 20).

The elements of an early gasworks included the furnace, which heated from below the airtight horizontal retorts (Illus 10 & 12) filled with coal; gravity-fed inclined retorts were invented in 1885 (Peebles 1980: 15) and later vertical retorts were used. Heat then distilled gas from the coal, leaving residual coke, which was removed before the retort was refilled with fresh coal. Raw gas, including impurities, would rise through an ascension pipe to pass to various treatment vessels (Russell 1973; Hide 2010: 7).

First, condensers cooled the gas in order to remove volatiles, which could otherwise have caused

pipe blockages when they condensed into viscous liquids. John Perks invented a ‘multiple inverted U-tube air-cooled design’ of condenser in 1817, which permitted tar and ammoniacal liquor to be siphoned off (Cotterill 1980: 32–3). Then the gas went through a series of structures to purify it and remove by-products.

The exhauster was invented by S Broadmeadow at Abergavenny in 1825 (Cotterill 1980: 34). These machines were especially suitable for the clay retorts of Scotland. They were ‘normally placed after the condensers, and pushed the gas forwards through the purifiers and on to the gasholders. By taking the full weight of “back-pressure” caused by the friction of gas passing through that apparatus, the exhauster reduced the pressure of gas in the retorts, thereby reducing damage to the retorts and drawing out larger volumes of gas from the coal’ (Cotterill 1976: 310). An efficient exhauster was invented in 1841 by John Grafton at Cambridge, following his time at New Street (Cotterill 1980: 34).

The washer was a simple gas-tight box where gas passed through perforated wooden boards running with water (Cotterill 1980: 35), the gas bubbling through water to absorb ammonia, carbonic acid gas and hydrogen sulphide (Russell 1973; Hide 2010: 7). The gas then passed through the scrubber, which was ‘very similar, but in the form of a tower with elaborate sleeves and a water-spray at the summit’ (Cotterill 1980: 35) where sulphuretted



Illus 12 Horizontal retort benches and double furnace in process of demolition (© HES)

hydrogen was removed. It was the rise in ammonia prices in the late 1860s that led to the technological development of washers and scrubbers ‘to remove saleable ammonia and residual tar from gas’ (ibid).

The gas would then go through a purifier, initially using lime though later iron oxide was utilised. Dry lime had been used for purification as early as 1806, while Samuel Clegg introduced wet liming, purifying gas by means of a bucketful of lime suspended in water. In 1817, Reuben Phillips of Exeter patented gas purification using slaked, or damp, lime, although this was not widely adopted until the 1860s. Instead, dry liming was at first popular in provincial Britain, as the residue could be used as a fertiliser. The residue from wet liming, known as ‘blue billy’, was noxious and difficult to dispose of. From around 1850, iron oxide came to be used for purifying. Sulphur compounds such as sulphuretted hydrogen could combine with the iron oxide to form iron sulphide (Williams 1981: 15).

The gas product would be sent to a gasholder for storage before distribution through a pipe system, while wells were used to store liquid and

tar (Russell 1973; Hide 2010: 7). The quantities of gas produced and stored would need to be gauged, and Samuel Clegg took the first patent for a ‘wet gas meter’ in 1815, with dry meters being introduced around 1850 (Peebles 1980: 15). The meter house monitored the storage and capacity of the gasholder to indicate the volume of production, supply and demand (Sproat 2006: 34). Another vital element of the gasworks was the coal store, which had to be kept well ventilated as coal oxidises when in large heaps, raising its temperature and leading to a ‘danger of spontaneous combustion’ (ibid: 33, 37).

4.2.1 By-products

A large part of the area of a gasworks was taken up in removing impurities from the gas, including plant for the recovery of those by-products, such as ammonia and coal tar, that could be profitably used elsewhere (Wood 1982: 4).

Albert Winsor produced two pamphlets in favour of the gas production process in 1804, which are referenced by Hunt (1907: 94–5). He indicates

that five ‘costly products’ can be gained from the smoke from the combustion of fuel, ‘viz. oil, pitch, acid, coke and gaz’ (ibid: 96). Among the many benefits enumerated by Winsor is ‘the value of oil and pitch, to be collected from the condensator’ (Hunt 1907: 99). Additionally, the acid recovered ‘is a very powerful astringent lie, far superior to all kinds of bark in tanning skins, &c., estimated only at triple value of the coals’ (Hunt 1907: 100).

Therefore, substantial quantities of by-products from coal gas production could be collected for profitable resale, including coke, tar and ammonia liquid:

Coke could be broken into pieces of small, uniform size and sold for domestic use with the benefit that it would produce heat without the polluting black smoke of coal fires. Tar could be mixed with clinker, ashes and ground granite for surfacing footpaths, and processed to make creosote to preserve railway sleepers. Ammoniacal liquor from the gas scrubbers could be converted into sulphate of ammonia for use as a powerful agricultural fertiliser. Sale of the residual coke and other by-products from the gas making process could recoup about half of the cost of coal. (Hide 2010: 6–7)

Even the lime used in the purifiers of early gasworks could be resold, after use, as a fertiliser, though this was unfortunately a means of spreading pollution (Thorsheim 2006: 141).

One of the major products of gas production, coal tar was ‘much in demand for naval purposes’ and was used to protect roofs (Butt 1967: 148). Naphtha was of more value than tar or liquor, as it was used ‘as a solvent, especially for Macintosh’s rubberized fabrics’ (Cotterill 1980: 32). Macintosh discovered that coal-tar naphtha produced in the distillation of pitch from tar ‘could be used as a solvent for India-rubber and therefore was essential for waterproofing textiles’ (Butt 1967: 149). He patented in 1823 ‘his double-layered cloth’, using ‘about six thin coatings of rubber in naphtha brushed onto the interior side of both layers to allow thorough solvent evaporation and “drying” before sealing them with a final sandwich of solution’ (Cotterill 1976: 544).

4.2.2 Development of new techniques

In the early 1870s, Professor Thaddeus Lowe invented a process for the production of water gas ‘comprising hydrogen, carbon monoxide and certain other substances’ with a high calorific value but unfortunately ‘little illuminating power’. In order to increase both these qualities ‘the gas was fed into a carburettor, a brick checker work chamber’ and enriched with oil to produce carburetted water gas (CWG) (Peebles 1980: 13–15). This technique spread so that ‘most medium and large town gasworks in Britain operated water gas plant at some point during their operational history’ (Thomas 2014b: C5). The water gas production process ‘generated gas through the action of steam upon red-hot carbon (generally in the form of coke). The generator would be filled with fuel, ignited and brought to temperature through the “blow” phase. Once brought to temperature, the system would enter the “run” phase and steam would be admitted. The gas was produced on the principle that heated carbon acted as a reducing agent for the steam as it passed through, the oxygen in the water combining with the carbon and giving off hydrogen gas’ (Thomas 2014b: C5). Furthermore, ‘the plant used to purify water gas was similar to coal gas, but additional plant was used to attempt to separate the CWG tar from water, eg tar separators and settling tanks’ (Thomas 2014b: C12).

Regenerative firing was introduced in Britain around the same time as carburetted water gas and was a cost-saving technology that reduced wear and tear on gasworks plant. In regenerative firing ‘the fuel gas is heated within the [retort] setting by a secondary air supply, previously heated recuperatively by the waste gases of combustion’ (Webber 1918: 22–3). This technique reduced coke fuel consumption and ‘more evenly heated the horizontal retorts, increasing their lifespan’ (Cotterill 1980: 27). Herring, describing the use of this system late in the life of the New Street works, notes that half of the air supply used for carbonising coal was ‘primary air’ while half was heated by recycled hot waste gases, using the gaseous-fired system first applied by Sir William Siemens in Germany (Herring 1907: 81) in the late 1850s to ‘increase furnace efficiency’ (Cotterill 1980: 26–7). This technological advance was facilitated within

gasworks by the introduction of more heat-resistant fireclay retorts from around the 1850s.

4.3 The development of the gas industry in Scotland and the beginnings of Edinburgh's gasworks

It was in the provision of street lighting that coal gas found its first major utility in the early 19th century. According to the *New Statistical Account*, attempts had been made as early as 1554 to introduce street lighting to Edinburgh, 'by hanging out bowets or lanterns from certain places fixed upon by the magistrates, which were to be kept lighted for four hours' (NSA 1845: 758). The town's magistrates further ordered, in 1684, that 'a lantern with a burning candle ... was to be hung out at the first story [sic] of every house, under a penalty of five merks' and 'in later times, the streets were pretty well lighted up by means of oil lamps till the introduction of coal gas' (ibid). In 1701 Edinburgh Town Council appointed the first public lamplighter in the Old Town and by 1786 the Council maintained 307 lamps (Shakhmatova et al 2012: 4–5) while the Committee of Police Commissioners in August 1820 wanted contractors to use 'the best Greenland whale oil' for street lighting (ibid: 7).

The origins of gas production in Edinburgh can perhaps be traced to James Milne, 'a journeyman brassfounder, who in about 1816 built gas apparatus both for his own Edinburgh premises, and to light the three main shops in that city' (Cotterill 1976: 82). In 1817, it was reported that 'in the course of the last and present years, manufactories, shops and private houses, in Edinburgh and its vicinity, have been lighted up with the gas from pit-coal; and extensive gas-works are now in progress for the purpose of lighting the public streets' (Edinburgh Observer 1817: 5–6). Early use of coal gas in Edinburgh and its environs appears to have included the erection of 'apparatus on the improved construction for the purpose of lighting up his own works and dwelling-house' by 'Mr Gutzmer, proprietor of the Foundry on Leith Walk' (ibid). Mr Gutzmer then built similar apparatus for other commercial premises including: 'Mr Haig's extensive distillery at Lochrin'; 'Mr Blackwood's shop in College Street'; 'the spacious shop and large warehouses of Mr Henderson, grocer' and

'the shop of Mr Scott, apothecary' (ibid). The latter two establishments are said to have used gas lighting during the winter of 1816–17 in order to produce 'a most brilliant illumination', and further 'elegant shops' were planning to make use of gaslight for display. Mr Gutzmer also provided gas apparatus for 'Messrs Lizars, engravers, St James's Square', providing not just lighting but also 'heat for the plates; and thus the use of stoves or small furnaces for the same purpose, a necessary but oppressive appendage for the workmen, is now entirely superseded' (ibid).

Thus Edinburgh found itself at the vanguard of the development of the commercial use of gas and similarly of gasworks technology. Edinburgh and its municipal rival Glasgow set up the first gas companies in 1817, five years ahead of any other Scottish burgh (Cotterill 1976: 121). Apart from London, only a few towns in England had by that time already developed a public gas supply, including Preston, where an Act of Parliament in 1815 led to the forming of the Preston Gas Light Company, and where Samuel Clegg's assistant John Grafton acted as engineer (Awty 1974; Thomas 2014a: A6); Grafton would go on to have a major role in the development at New Street.

In 1816 Kincaid Mackenzie, merchant and chief magistrate in Edinburgh, led a deputation of ten local merchants and tradesmen to petition Edinburgh Council for permission to supply gas in the city. The members ... owned property or were residents in the city and had first met in May 1816. (Cotterill 1976: 153)

In a recent study of the English gas industry (which is of use in understanding the wider British industry), Russell Thomas has described the development of the ownership of these enterprises, with the running of the industry moving from private individuals, to private companies operating in municipalities (such as Birmingham), before commonly being taken over from the late 19th century onwards by municipal authorities in order to better organise the ever increasing supply (Thomas 2020a: 2). The ownership models included 'private ownership, company ownership and municipal ownership' and 'most [early] gas undertakings had

statutory powers resulting from an Act of Parliament to break open the streets, lay gas pipes and provide gas lighting, though many small undertakings were established without these powers' (ibid). The Edinburgh Gas Light Company was one such private company, which required its own Act of Parliament to function in Edinburgh. It was established in 1817 (NSA 1845: 758), with a Prospectus being issued in March 1817 (NRS GD504/3/97/11). Its preamble optimistically noted that, 'The use of Inflammable Air from Coal, as a substitute for oil or tallow, in lighting Streets, Warehouses, Shops, Manufactories, Public Offices, and Dwelling-Houses is now completely established in London and elsewhere in England, and from its economy, safety and brilliancy, bids fair, in a great measure, to supersede every other mode of lighting.' The Edinburgh Gas Light Company initially aimed to raise £20,000 sterling capital divided into 800 shares of £25 each, which it was believed was sufficient for 'erecting the Works and Apparatus, Laying the Mains and Branch Pipes' and also 'to light with Gas such a proportion of the principal Streets, Shops, &c, in the City, as will enable the Subscribers clearly to ascertain how far this mode of lighting will prove beneficial to the Public at large and yield an adequate return to the Company'. However, even at this early stage the Prospectus envisioned a potential need for further 'New Stock ... to embrace the lighting of the whole of the Old and New Extended Royalty, and Places adjacent' (NRS GD504/3/97/11: 1). The company's business was defined as the 'manufacture of Gas or Inflammable Air from Coal, and lighting therewith the Streets, Lanes, Shops, &c of this City, disposing of the Coke, Oil, Tar, Pitch, Asphaltum, Ammoniacal Liquor, and Essential Oil, the produce of the manufacture' (NRS GD504/3/97/11: 2).

In 1818 an Act of Parliament allowed for gas production to light the city of Edinburgh (NRS GD504/3/97/14). The Act of 1818 noted the benefits to Edinburgh's citizenry of the better lighting of 'Streets, Squares, Public Passages and Places, and Houses, Shops and Manufactories' and that inflammable air from coal could be 'safely and beneficially used for lighting'. It permitted the company to raise money to erect and keep gasometers 'and all other Works and Conveniences belonging or requisite thereto' (NRS GD504/3/97/14: 1, 3).

On incorporation in 1818 the original governor of the company was Kincaid Mackenzie, then Lord Provost of Edinburgh, while its deputy governor was Sir John Marjoribanks, Baronet of Lees, who had been Lord Provost between 1813 and 1815. The desire of citizens of high status to be associated with the company is clear from a list of its founding subscribers contained within the 1818 Act, which includes William Arbuthnot, another former Lord Provost (between 1815 and 1817), and Alexander Henderson, Lord Dean of Guild, and many more significant officeholders and academics (NRS GD504/3/97/14: 2, 23; Mullay 1996: 208). The Company was led by a group of men from the aristocracy, professional and mercantile classes, commonly resident in Edinburgh. The nature of the company's investors in 1821 has been analysed by Cotterill:

Of the twenty-five Directors listed in the Edinburgh company's Act of 1818, only Sir George MacKenzie of Coul had withdrawn his support by 1821. All of the remainder were genuine investors, many of them still Directors. Bankers invested only small cautious sums in the company ... The main centre of support was nevertheless the professional classes and the gentry. 79 investors from the former included 31 solicitors and lawyers, and the professional class dominated the highest investment bracket. As heavy investors they were closely followed by the gentry of whom 88 invested over all categories ... The third principal source of finance was from retail shopkeepers with 41 investors including 10 in the highest bracket, followed by wholesale merchants, and then industrialists. (Cotterill 1976: 205)

Additionally, 'very few investors lived outside Edinburgh, and the Rev. J Abernethy (III) of Bolton and J Barker (III) of Oldham were the only Englishmen' (ibid: 206).

The New Street Gas Works was built soon after the passing of the Act of 1818 and was one of Britain's earliest gasworks, following the development of a system for using gas for lighting by the German chemist Friedrich Accum (Adamson et al 2016: 151). John Grafton, a pupil of Samuel

Clegg at the London Chartered Gas Co (Cotterill 1980: 20), was the first trained specialist at the New Street Gasworks and is believed to have ‘designed and overseen the building of much of the gasworks’ (Adamson et al 2016: 189). This was an example of the importing of skill in gasworks to Scotland from London, the focus of the early industry (Cotterill 1976: 104). Prior to the passing of the Act of Parliament of 1818, Grafton arrived to ‘survey Edinburgh and estimate the costs of a gasworks’ (ibid: 153–4). Roofed buildings would have covered the retorts, lime stores, purifying apparatus and coal stores of the works as well as the gasholders, which ‘at this time would have been of wood on an iron frame suspended above a water-filled pit’ (ibid). The manager of the New Street Gasworks from 1818 to 1859 was John Watson, ‘... a non-scientist but an acute businessman who left the technological aspects to J Grafton’ (ibid: 157).

In Edinburgh responsibility for street lighting had passed in 1785 to the Police Commissioners. The Commissioners’ Minute Books for November 1819 note, ‘... that part of the High Street from the Tron Church to the Parliament Close shall on both sides be forthwith lighted with gas’ (Shakhmatova et al 2012: 6–7). In 1821, the governors and directors of the Gas Light Company intimated that there had been several meetings between the directors of the company and the committee of the Commissioners of Police with regards to the lighting of Edinburgh’s principal streets, which had led to ‘part of the High Street, the North Bridge, and the corners of several of the streets from Prince’s Street to George Street, &c’ being ‘for some time lighted with gas by mutual consent of the Committees by way of experiment’ (NRS GD504/3/97/7: 2). A year later the governor and directors reported that they had made an arrangement with the Commissioners of Police ‘to light the whole of the High Street, North and South Bridges, and Nicholson’s Street, and latterly Prince’s Street, Charlotte Square, George Street (both sides), York Place, and Picardy Place, &c.’ (NRS GD504/3/97/5: 1).

The New Street site was developed ‘as the centre for Canongate’s supply’ (Adamson et al 2016: 151) and ‘in the spring of the following year [c 1818], the shops on the North and South Bridges were lighted up with this brilliant light’ (NSA 1845: 758). One source indicates that on 20 April 1818

‘the company commenced giving this brilliant light to such shops as had taken branches from the pipes in the principal streets. The theatre commenced lighting with gas on the 3rd December 1818; and now all the streets in the city are furnished with gas lamps’ (Stark 1834: 306). An advertisement in *The Scotsman* newspaper of March 1823 indicates that gaslight was being used to illuminate an exhibition of ‘Belshazzar’s Feast and Joshua’ at the Calton Hall on Waterloo Place, Edinburgh (Edinburgh Corporation 1926: 17, Advertisement from *The Scotsman*, March 1823).

The NSA (1845: 758) further describes the rapid and broad spread of gas lighting through Edinburgh as ‘next winter [c 1819] the theatre and public streets were lighted up, and in a short time, gas was very generally introduced into private houses’. By 1830 it is said that there were 5,300 gas street lights in the city (Chambers 1830: 89), though Shakhmatova et al (2012: 20) suggest that by 1847 the number of public gas lamps in Edinburgh was up to 761, and perhaps a proportion of the street lights in 1830 were still fuelled by oil.

4.4 The further development of the New Street Gasworks

In Edinburgh, by the 1840s, the various ‘Flesh, Fish, Poultry and Vegetable Markets’ set up in proximity to the New Street works in 1819, were ‘fitted up with gas’ (McDowall & McDowall 1842: 99). As well as supplying gas for lighting public spaces, the New Street Gasworks also supplied private houses, as a letter from the company notes the use of meters for ‘large Establishments and Private Houses’ (NRS GD1/1246/1_c). The introduction of gas supply to ‘a number of Private Houses’ is confirmed in a letter of March 1825 (NRS GD1/1246/1_g). Indeed, Cotterill suggests that in the 1830s progress in the lighting of dwelling houses was much greater in Edinburgh in comparison with London (Cotterill 1976: 1218). Another early use found for gas was the lighting of public clocks, as ‘the clock on Edinburgh Tron steeple was lit in 1823’ (Cotterill 1976: 1249).

As early as June 1821, at a meeting of the Edinburgh Gas Light Company’s proprietors, it was being stated that increasing demand for gas had necessitated ‘a further expansion of the Company’s Works’ and that at their last meeting (in 1820),

the company 'had entered into Contracts for the erection of an additional Retort House, a New Flue or Chimney, Four New Gasometers, and Tanks, and corresponding Buildings, and additional Pipes, &c, the estimated expense whereof was calculated at £18,000 Sterling'. Although these works were nearly completed by June 1821, they led to a new share subscription (NRS GD504/3/97/7: 1). Other alterations to the Gasworks site noted at this time included a new road entrance to the works and to the High Street, which had transferred entry to the east boundary of the works, as an old road was 'occupied by, or included in the sites of the four new Gasometer-Houses'. Additionally, the construction of a new wall along the North Back of the Canongate meant that the east and the north sides of the works were to be wholly enclosed, having formerly been open (NRS GD504/3/97/7: 2). The expansion of the works appears to have been completed by June 1822, when it was reported that the 'Four New Gasometer Houses and Cisterns, – an additional Retort House, – a New Flue or Chimney, – and a Steam Engine, not only for a supply of Water to the Works from a pit-well, but also constructed as to turn the Lime Purifiers' were completed and operational (NRS GD504/3/97/5: 1).

A questionnaire filled out by the company in November 1825 gives some details of the workings of the retorts at New Street. Each 'oven' is described as having five circular retorts, 12 inches in diameter. An average of 140lb of cannel or parrot coal was used in each charge of the retort, with 46lb of coal used in the furnaces for each charge of the retorts. Each charge is said to take between four and a half and five hours to work off, and the retorts, which were worked constantly, lasted seven or eight months (NRS GD1/1246/1_j). New Street was unusual in its use of advanced technology, as generally Scotland appears to have 'lagged behind' England in such multiple retort technology, with direct heating of single retorts being normal practice in the 1820s and 1830s. As early as 1817, A Rackhouse's 'oven plan' had been developed in London, with three or more retorts heated together by controlled 'indirect heating' (Cotterill 1980: 25).

However, another potential innovation was not taken up at New Street at this early date – the use of fireclay rather than cast iron in retorts. This was in spite of John Grafton, the New Street works'

specialist, having 'devised a fireclay lining for iron retorts in 1818', and having created retorts made entirely of fireclay in 1820 (Cotterill 1980: 25–6). The cast iron retorts first used in the production of 'town gas' were 'costly and short-lived in consequence of the perishing of the metal' (Webber 1918: 9–10). Cotterill notes that 'cast iron retorts were an expensive aspect of early working costs because they corroded rapidly at high temperatures or cracked in half when cooling ... Clay retorts were only one-sixth as expensive, and their widespread adoption was an important stimulus to the Scottish gas industry. The problems with iron retorts led John Grafton to experiment with fireclay while employed on the construction of Edinburgh gasworks ... The new Edinburgh company was unwilling to try this radical design, but Grafton persuaded several English gasworks to experiment with it' (Cotterill 1976: 280–2). However, in 1832, clay retorts were introduced at the Edinburgh Gas Light Company, which entirely superseded iron by 1838 (ibid: 290).

The Gasworks was located on the heavily occupied ridge between the Old Town and Holyroodhouse. This central location would have 'reduced the amount of pumping needed to move the gas to its customers' (Adamson et al 2016: 189). It was also at not too great a height as 'the expanding properties of rising gas ... required forceful pumping to reach the lower level supply zone' (Cotterill 1976: 132). The NSA provides an early description of the Gasworks in the Canongate, noting that they were 'extensive, and contain eight gasometers'. It also records that in 1825 the Edinburgh Gas Light Company purchased the works at Tanfield, where a failed attempt had been made to manufacture gas from oil rather than coal, the Tanfield site being used by them 'for the supply of the northern portion of the town' (NSA 1845: 758). Other sources indicate that this purchase occurred in 1829 (Edinburgh Corporation 1926: 17). McDowall's *New Guide* of 1842 states that the early New Street Gasworks were 'distinguished by their three lofty chimneys' (McDowall & McDowall 1842: 39).

The Edinburgh Gas Light Company initially faced competition from various sources, notably the Edinburgh Oil Gas Company set up in 1824 with their works in the Tanfield area of Edinburgh (Edinburgh Magazine and Literary Miscellany 1824; Groome 1884: 526; Edinburgh Corporation

1926: 17). Another competitor in the early days of the New Street works was the Leith Gas Light Company, formed by an Act of Parliament of July 1822 to supply gas in Leith; in 1824 it obtained a contract to supply gas to public lamps (McGowan 2012: 263).

The letter book of the Edinburgh Gas Light Company held in the National Records of Scotland (NRS), written between 1823 and 1829 (NRS GD1/1246/1_a), details the company's correspondence, commonly concerning competition with the Oil Gas Company at Tanfield and others. A letter in November 1823 remarks on fears of the opposition of the 'Oil Gas Establishment', but also notes concerns about the Leith Gas Light Company, the 'neighbours in Leith', who 'finding they are to do no good there (in Leith), have resolved to try the more prolific territory of this city, and run the hazard of stepping beyond the power of their Act of Parliament' (NRS GD1/1246/1_d). There appears to have been some public debate on the relative merits of whale oil and coal gas for producing light, for example in *The Edinburgh Magazine and Literary Miscellany*, where a series of letters describe the competing claims of the gas supply companies with regard to their 'illuminating powers' and cost value (Edinburgh Magazine and Literary Miscellany 1824: 736). A letter of May 1824 indicates that the Oil Gas Company had purchased ground at Tanfield and issued specifications for gasometers, tanks and pipes and notes that they 'promise light to the public early next winter'. This letter indicates that an 'Oil Gas Work' had been in operation in Leith 'since August last', as the Leith Gas Light Company also utilised whale oil (NRS GD1/1246/1_f). A letter dated March 1825 indicates that the Edinburgh Gas Light Company 'now [had] two Oil Gas Companies to compete with, the one from Leith, and the other a very extensive one in Edinbr.' (NRS GD1/1246/1_g). The Tanfield operation was chaired by Sir Walter Scott, and this letter opines that he 'knows much more of bookmaking than Gas making' (ibid). Another letter of 1825 notes with a degree of *Schadenfreude* 'a dreadful explosion which took place here from Oil Gas on last Wednesday evening', noting that the explosion occurred in a private house supplied by oil gas and that 'there can be no doubt Oil Gas will explode much sooner, and with far greater violence than coal gas' (NRS

GD1/1246/1_h). The public feared suffocation or explosions from leaking gas from gasworks as 'accounts of such events appeared with disconcerting frequency in newspapers and magazines' (Thorsheim 2006: 142).

As a result of all these factors, the operations of the Oil Gas Light Company at Tanfield were unsuccessful and by 1829 the Edinburgh Gas Light Company owned the defunct Oil Gas Company's works at Tanfield, although an Act of Parliament of 1829 indicates that at that time they were not permitted 'to manufacture Gas from Coal at their works at Tanfield' (GD504/3/97/2: 12). Gas was conveyed by pipes from the New Street works to four gasometers at Tanfield, while there were eight gasometers at Canongate (Stark 1834: 306). By 1834 more than 202,739 cubic feet of gas were being produced at New Street Gasworks daily (ibid).

The Gas Light Company therefore appears to have held a near monopoly on gas supply within Edinburgh (but not Leith). In 1829 an Act of Parliament was passed to permit the Edinburgh Gas Light Company to raise further funds, as the original sum raised (£100,000) had been expended (GD504/3/97/2: 1). The requirement for further funding appears to have been caused by the expansion of Edinburgh as its 'Suburbs are in a state of constant increase, in consequence of which a larger supply of Gas has been required' (ibid). The Company was permitted to raise a further £50,000 sterling, and to 'produce Gas ... from any Materials capable of producing the same' (ibid: 2, 4).

Later competition for the New Street Gasworks took the form of the 'Edinburgh and Leith Gas Company', set up in 1839 which, working from a gasworks in Leith, supplied both Edinburgh and Leith (NSA 1845: 758). It was also known as the Edinburgh and Leith Gas Light Company (Edinburgh Corporation 1926: 17). This company 'purchased the gas-works in Leith, belonging to a previous company', the works of the ultimately unsuccessful Leith oil gas concern (Groome 1884: 526). Cotterill notes that it was an unusual early example of competition in municipal gas supply and that 'great difficulty was found in obtaining permission for a gasworks in Edinburgh, until the small existing supply from the Leith company was exploited as a flaw in the defensive monopoly of the Edinburgh company' (Cotterill 1976: 1128).

Cotterill notes the existence of further competing companies in the mid-1840s, including the Union Gas Light Company, the Edinburgh New Gas Light Company and the City of Edinburgh Gas Light Association (ibid: 1138–9). The Edinburgh Gas Light Company continued in direct competition with the Edinburgh and Leith Gas Light Company during the mid-1800s, to the extent that ‘duplicate mains were laid in all the principal thoroughfares, as well as separate service pipes to shops, houses and tenements’ (Edinburgh Corporation 1926: 17). This continued until 1866 when a ‘districting agreement’ divided the Edinburgh and Leith area between the companies (ibid).

A major expansion of the New Street Gasworks occurred in the 1840s, which is represented in the 1854 Ordnance Survey map, surveyed in 1852 (Illus 8). It appears that there were as many as 68 furnaces in operation following the Gasworks’ redevelopment in the 1840s, when George Buchanan constructed the works’ major chimney (Civil Engineer and Architect’s Journal 1851: 34). These 68 furnaces used 34 tons

of coal every 24 hours and required ‘a current of air at the rate of 10,000 feet per minute, which the old chimneys were incapable of drawing’ (ibid). The new chimney was a highly visible element of the Edinburgh townscape for many years (Coghill 2008), and survived until its demolition in 1930 (Adamson et al 2016: 151). Buchanan was a civil engineer who had a reputation for building harbours and bridges, and in 1848 he ‘... began the work of erecting the huge chimney, nearly 400ft in height, of the Edinburgh Gasworks ... [and] he carried out an exhaustive series of experiments to ensure its stability’ (Skempton et al 2002: 93; Illus 13 & 14). The chimney base measured 40 feet 6 inches (12.34m) square at the bottom, which was 12 feet (3.66m) below the ground surface. At the ground surface it measured 32 feet 6 inches (9.90m) (Taylor 1851: 35). The chimney was ‘an important source of motive power, because as hot air escaped up it a draught of fresh air was drawn in to ventilate the retort house and fire the furnaces. Edinburgh found three chimneys, up to 148 feet high, quite inadequate

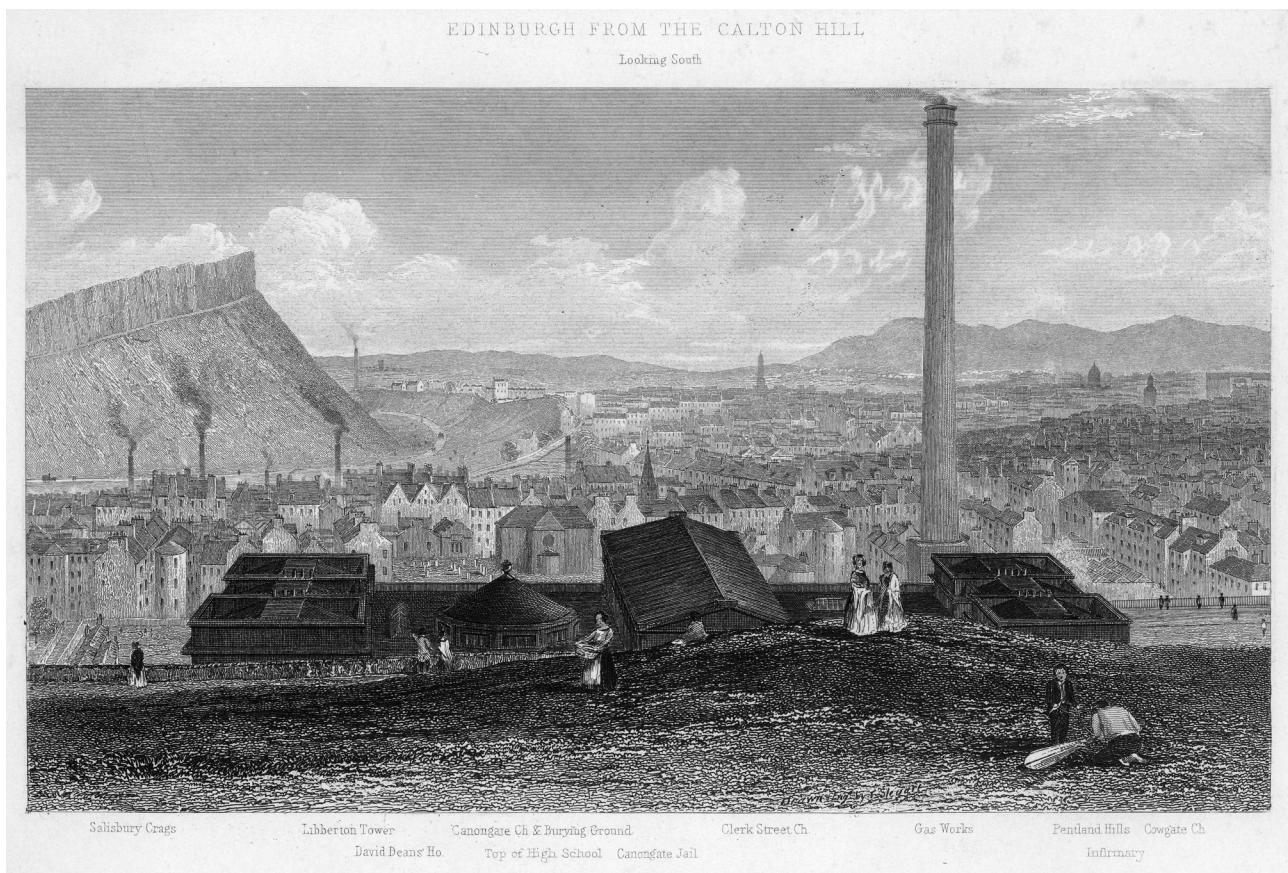

Illus 13 Engraving of the city of Edinburgh from Calton Hill showing the New Street Gasworks Chimney (© HES)



Illus 14 The New Street Gasworks main chimney seen through the Edinburgh smog in the late 19th century (© HES)

for the sixty-eight furnaces and 178 retorts which were in service' (Cotterill 1976: 310).

It appears that the expansion of the works did not go entirely to plan as, according to *The Satirist* of 3 February 1849, a 'destructive explosion' occurred 'at the works of the Edinburgh Gas Company, which resulted in the almost entire destruction of the splendid new gasometer latterly erected on the ground which once formed the garden of the late Dr Buchanan, minister of Canongate parish' (Satirist 1849). Cotterill expands on this, noting that 'Edinburgh installed the largest Scottish telescopic gasholder in 1848, 100 feet in diameter, forty feet high, with a capacity of 300,000 cu ft. The following year, however, a guide rod snapped and friction ignited the gas which destroyed the holder and nearby houses' (Cotterill 1976: 325). These new works, when completed, were of some interest to the public, including aristocracy; in 1859 the Prince of Wales 'made a point of visiting the works of the Edinburgh Gas Company' (Ladies' Treasury 1859).

While originally the Gasworks at New Street

was set up as a private enterprise, in common with many towns and cities, the gas supply was taken over by the local authorities of Edinburgh and Leith under the Edinburgh and Leith Corporation Gas Commissioners in 1888, when the Edinburgh Gas Light Company and the Edinburgh and Leith Gas Light Company were joined together (Scottish Gas Board 1960: 3). In 1920 the Commission would in turn be dissolved and its role taken over by Edinburgh Corporation (Edinburgh Corporation 1926: 21).

On coming under the management of the Edinburgh and Leith Commissioners in 1888, major renovation works were required at New Street, as 'the Edinburgh company had allowed New Street gasworks to fall into disrepair ... This included a new bench of forty ovens each with eight retorts, heated by carbonic-oxide combustion from producers' (Cotterill 1976: 1064–5).

One of the main incentives for the growth of carburetted water gas (CWG) and other technologies in Britain around 1890 was the increasing expense of cannel coal (Webber 1918: 14–16), previously

utilised for the production of carbonised gas with a high candle power or ‘calorific’ content. The ‘cannel coal crisis’ of 1892 led to the use of poorer-quality coal, which produced gas of a lower candle power (Cotterill 1980: 28). The impetus provided by increased coal prices and lower quality led to ‘the adoption of oil-gas enrichment processes, followed by water-gas to reduce working costs’, with the raising of coal prices between 1891 and 1893 (in part due to rising miners’ wages) even leading to ‘uneconomic experiments with peat carbonization ... in 1893 by Edinburgh Gas Commissioners’ (ibid: 22). By 1893, oil was used to enrich gas at New Street, a process requiring the use of ‘complex and expensive oil carbonization and re-cycling apparatus ... entirely separate from the coal gas retorts’ (Cotterill 1980: 28). It could use surplus coke ‘made available by regenerative firing’ and such plant was installed in Edinburgh in 1895 (ibid).

The introduction of CWG plant occurred late in the life of the New Street Gasworks (Herring 1907: 213) and appears to have been part of a major technological overhaul of the New Street works,

as they were ‘equipped in 1896 with mechanical stokers driven by hydraulic power, coal breaking and elevating machinery’ (Edinburgh Corporation 1926: 19). By the 1890s, the New Street Gasworks also utilised the technologically more efficient gaseous-fired or regenerative system, rather than the direct-fired system of heating retorts (Herring 1907: 80–1; Cotterill 1980: 27).

By the end of the 19th century, the New Street site was being employed to its full capacity and was unable to cope with increasing demand. New Street was one of three ‘manufacturing stations ... in a most congested state’ (Herring 1907: v) in Edinburgh, supplying half a million people, its cramped site prohibiting its expansion. Gas production at New Street in the late 1890s was 6,920,000 cubic feet per day on a 4.5-acre site. At this time the New Street works did not utilise on-site gasholders, supplying gas directly with surplus gas being held at ‘six different depots’ in Edinburgh and Leith (ibid). With the employment of Walter Ralph Herring by the Edinburgh and Leith Gas Commissioners as the engineer in charge



Illus 15 Removal of the horizontal retorts in 1911 (© HES)

of Edinburgh's gas supply in 1897 (Scottish Gas Board 1960: 3), it was decided that Edinburgh's gas-producing plants required complete reconstruction to facilitate adequate gas supply for the city (Herring 1907: v). Ultimately, this led to the closure of the New Street works and the construction of the new gasworks at Granton (Scottish Gas Board 1960: 3). These were constructed in two stages (1899–1902 and 1903–10) (Sproat 2006: 36) and were formally opened on 27 February 1903, with gas manufacture having commenced in 1902 (Herring 1903). It had originally been planned to keep the New Street works as a reserve source of power (Herring *c* 1906: 18) but in 1902 the Gas Commissioners decided to expand the Granton works with a 'second section of the works' in order 'to free the city of the incubus of the [New Street] works' (*ibid*: 18–19).

The New Street Gasworks was therefore demolished from around 1906 (Edinburgh Corporation 1926: 17) and images of the dismantling of the buildings on the site are held by Historic Environment Scotland (Illus 15), which show the removal of horizontal retorts in 1911. A few of the smaller buildings had been removed and only one rail track was present by the time of the 1914 Ordnance Survey mapping (not illustrated). After its closure, the Gasworks site was used in part, between 1900 and 1925, as Bathgate Park, a football pitch for junior team Edinburgh Emmet (Adamson *et al* 2016: 46). The edge of this 'Football Ground' is indicated on a plan dated 1923 of a proposed new workshop to be erected on the north-east corner of the Gasworks site (HES EDD 747/3).

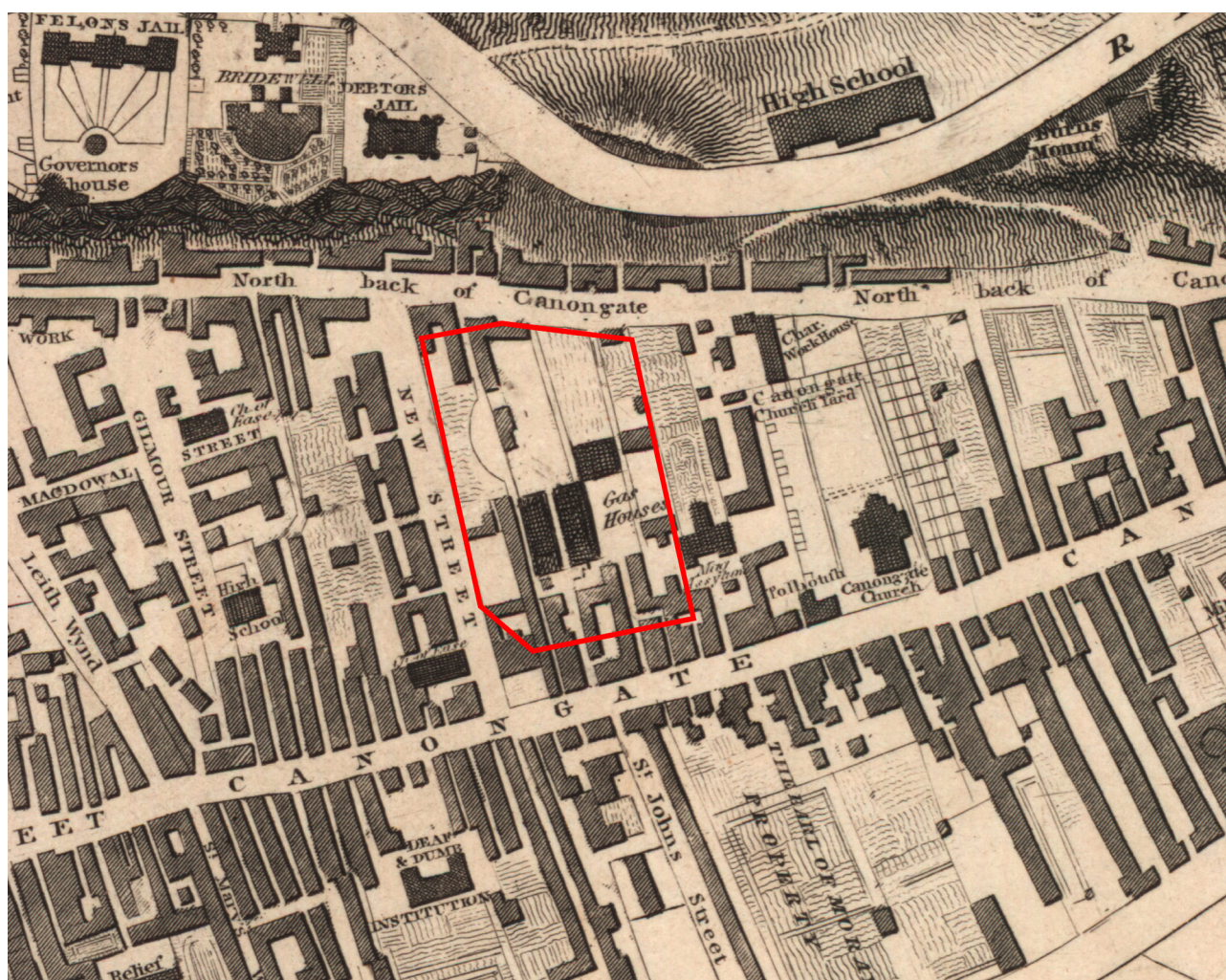

Illus 16 Detail from J Wood's 1823 *Plan of the City of Edinburgh, including all the latest and intended improvements*, Edinburgh: P Brown & T Nelson (Reproduced with the permission of the National Library of Scotland and under Creative Commons (CC BY 4.0))

4.5 The Gasworks and its surroundings: evidence from historic maps and plans

Prior to the Ordnance Survey maps of the mid-19th century, historical maps are varied in detail and ambiguous in the depiction of the development of the structures of the Gasworks. A constant in most mapping of this era is two parallel north/south-aligned blocks in the south-west of the area, while to their north-east is a major block, which had west, north and east wings around an open area to the south (roughly an inverted U-shape). Kirkwood's plan of Edinburgh of 1821 (Illus 7) depicts several buildings of the 'Gas Works', in the

centre of the area between New Street and Tolbooth Wynd, including those just mentioned, as well as a building (shaded in the same way) to the north-east, fronting on the North Back. However, it gives no indication of the functions of the various structures, though one was undoubtedly a retort house for the burning of coal to produce gas. The area, at this period, is far from wholly industrialised, with open areas representing gardens or cultivation depicted fronting on New Street to the west and north of the Magdalene Asylum (Canmore ID 133031), a psychiatric hospital founded in 1807, to the east.

The 'Gas Houses' appear behind the northern Canongate frontage buildings on Wood's map of

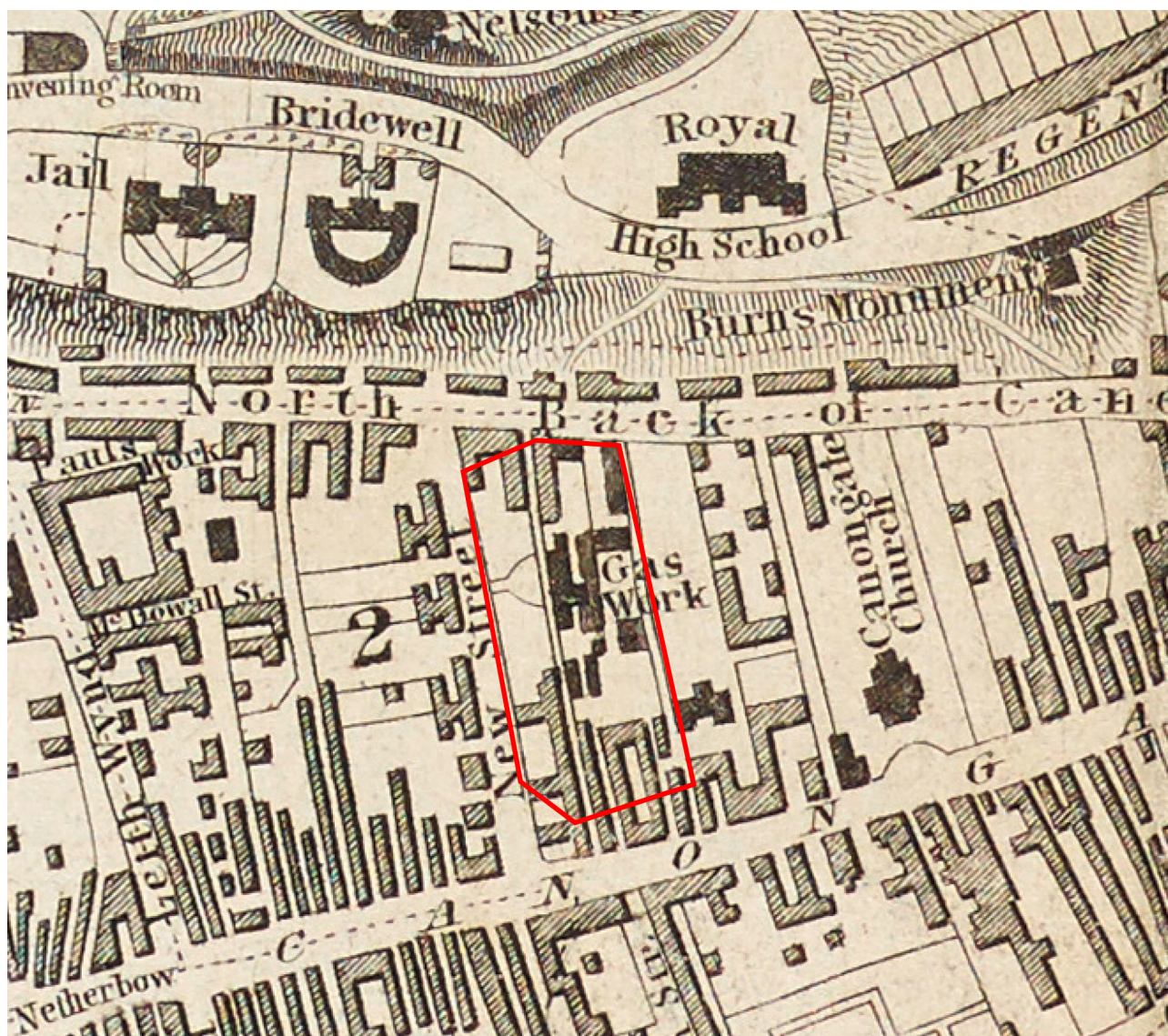

Illus 17 Detail from *Plan of Edinburgh and Leith. From the best Authorities. Engraved expressly for the Letter Carriers Directory, By W.H. Lizars, 1835* (Reproduced with the permission of the National Library of Scotland and under Creative Commons (CC BY 4.0))

1823 (Illus 16). The potentially associated building shown on Kirkwood's earlier map (shaded dark, like the other buildings of the Gasworks) on the south side of the North Back of the Canongate is not visible on Wood's map, suggesting its removal.

A map published by Hunter and Smith in 1828 (not illustrated) lacks detail but may indicate a new structure to the north of the main Gasworks block. However, the Lizars maps of 1835 (Illus 17) and 1837–8 (not illustrated), perhaps erroneously, indicate a much-altered arrangement of buildings in the 'Gas Works', with only two parallel north/south-aligned buildings still clearly recognisable from earlier maps. While not detailed, these appear

to show an expansion of the structures formerly present further north.

Kay's relatively detailed 1836 map (Illus 18) shows the 'Gas Works' with a similar layout to earlier maps, apart from a new building on the south side of the North Back (although James Kirkwood had actually depicted a building in this area in 1821). Lancefield's (1851) is the earliest map (Illus 19) to depict the alterations of the mid-1840s, with much of the area of the 'Edin. Gas Works', covered by major buildings. The location of the huge chimney that was a major element of the Edinburgh skyline into the 20th century is recognisable, and a gasholder is depicted to the north-west. There is

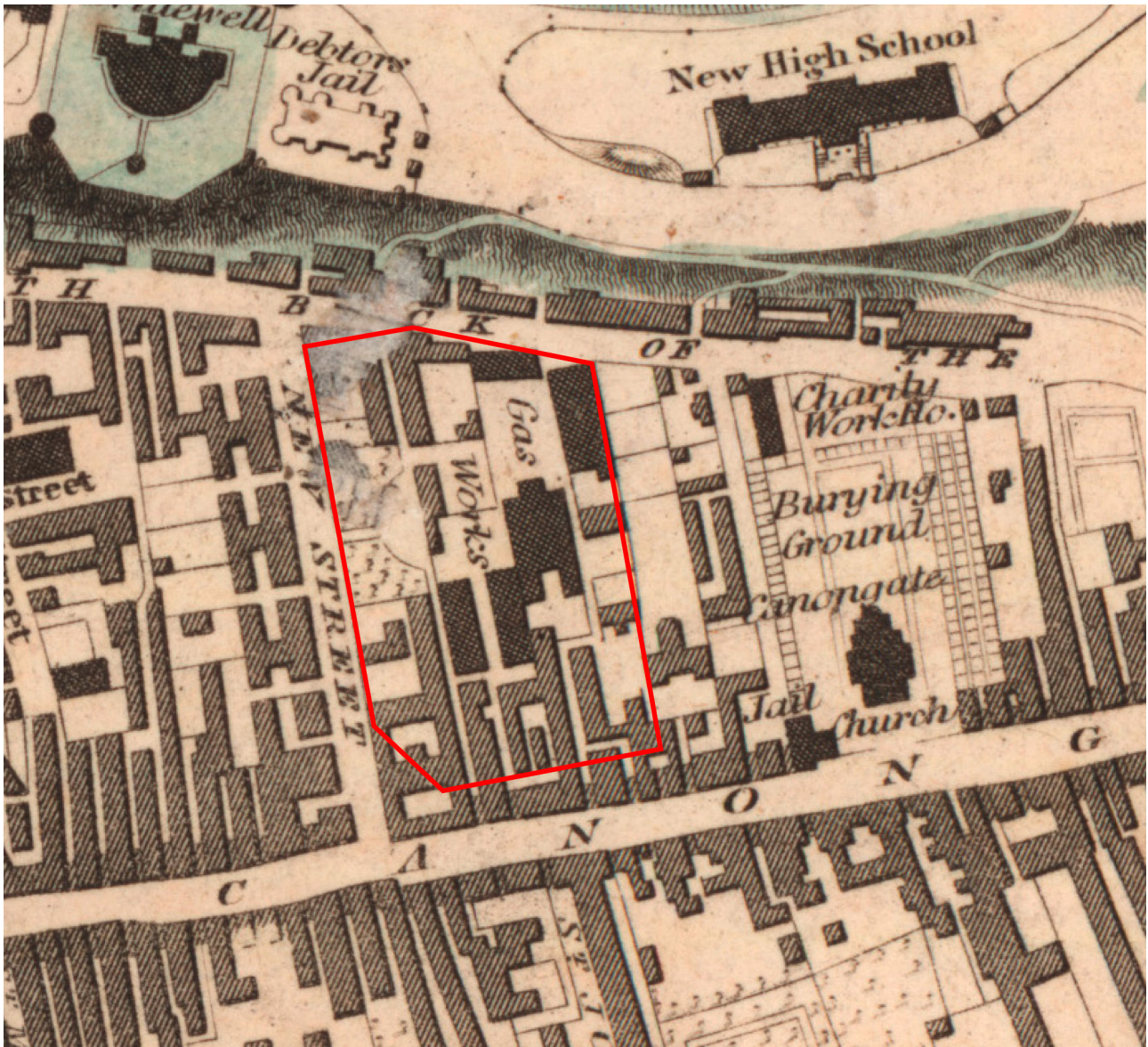

Illus 18 Detail from J Kay's 1836 *Kay's Plan of Edinburgh* (Reproduced with the permission of the National Library of Scotland and under Creative Commons (CC BY 4.0))

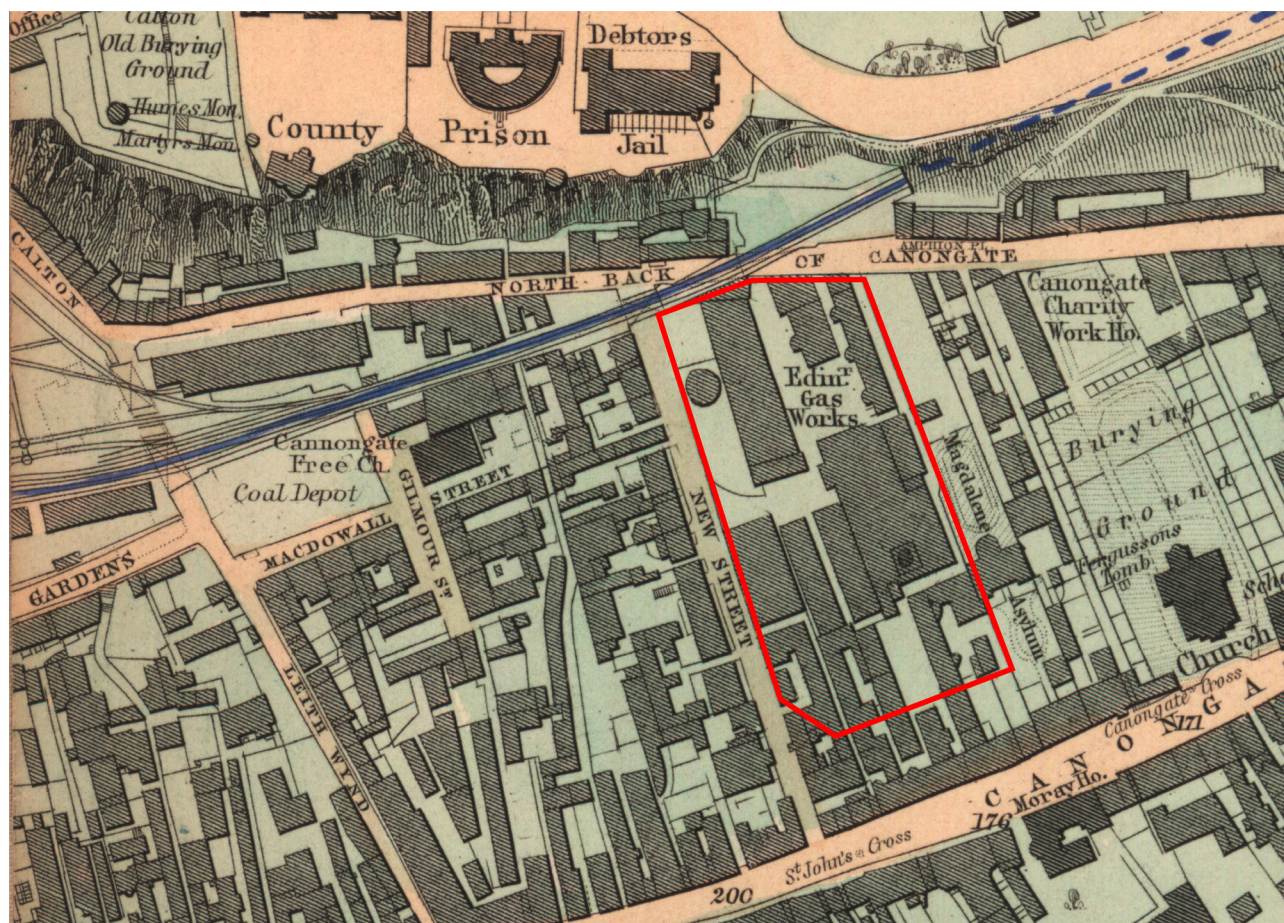

Illus 19 Detail from A Lancefield's map, *Johnston's plan of Edinburgh & Leith*. Edinburgh: W & A K Johnston, 1851 (Reproduced with the permission of the National Library of Scotland and under Creative Commons (CC BY 4.0))

some continuity in Lancefield's plan with earlier maps – the two parallel north/south-aligned buildings in the south-west of the Gasworks are still depicted, though the distinctive outline of the major building formerly visible to its east (with its open area to the south) is not visible, replaced by a major building block (with its chimney), representing the likely reconfiguration of the Retort House.

The Ordnance Survey map of 1854, the First Edition, surveyed in 1852 (Illus 8) shows numerous substantial structures of the 'Edinburgh Gas Works', including the circular 'Gasometer' to the north-west, near the 'Condensers', coal sheds and the 'Meter House'. Further, rectangular, gasholders and a smithy are located in the north-east of the area, while the south of the site contains further gasholders, two buildings labelled 'Purifying House', a 'Lime House' and the 'Fire Department Retorts &c.'. The presence of rectangular gasholders at this

date is unusual, as they apparently represent late survivals of early gasholder technology. Thomas notes that 'the first gasholders were rectangular and over-engineered, being constructed of iron with a heavy wooden frame' and that such designs were used by Samuel Clegg in his early gas installations (Thomas 2020b: 191–3, fig 3.162). The two north/south-aligned blocks in the south-west of the Gasworks appear still to be present – functioning as a block of 'Gas Holders', to the east, and a 'Purifying House' with 'Gas Holders' to the west.

Due to the industrial development of this area north of the Canongate, by 1852 the closes that formerly linked the Canongate with Calton Road had been blocked (with the exception of Shoemakers' Close) or only functioned as access points for buildings. A small 'Tobacco Pipe Manufactory' stood to the south of the Gasworks, with the 'Canongate Foundry' to the east. Clay tobacco pipe makers are

known to have worked in the Canongate since at least 1622, when the manufacturer William Banks is noted as a prominent pipe manufacturer until his death in 1659 (Gallagher 2008: 1). Another prominent clay pipe manufacturer appears to have later been located south of the Gasworks: Thomas White & Co, which operated from c 1825 to 1867 (Gallagher 1987c).

The North British Railway Company was established in 1844, and the East Coast Main Line between Edinburgh and Berwick-upon-Tweed was completed in 1846 (Adamson et al 2016: 50). On the First Edition mapping (Illus 8), the lines of the North British Railway Company are shown, with the main route to the east from Waverley disappearing beneath Calton Hill. On this detailed mapping, sidings running off the main line are clearly visible, entering the north end of the Gasworks, with a western siding ending to the north of the coal sheds, and an eastern siding ending adjacent to unlabelled buildings and Gasholders.

The Ordnance Survey 1877 map, published in 1881 (Illus 20) shows the Edinburgh Gas Works 'Coal Shed' has expanded eastwards, now covering the site of the former Canongate Foundry; the

Magdalene Asylum can clearly be identified, now subsumed within the Gasworks. The outline of the coal shed's plan and it has been suggested that the Gasworks incorporated such existing buildings, 'rather than knock down and rebuild' (Adamson et al 2016: 47).

Adamson et al (2016) have identified various 19th-century iron foundries in the area to the north of the Canongate. In Post Office Directories, the period 1838–53 saw James Blaikie & Sons, founders and engineers, listed at Panmure Foundry. From 1853 to 1859 they were listed as iron founders at Canongate Foundry in Tolbooth Wynd (ibid: 49–50). This is likely the foundry overbuilt by the Gasworks. The tobacco pipe factory is no longer present on the mapping of 1877, as the 'Fire Department' of the Gas Works had expanded southwards as had the 'Lime House'.

The coal shed and 'Fire Department, Retorts, &c.' are indicated as being supplied by an extensive complex of rail tracks entering from the north, connecting with the North British Railway, likely for the delivery of coal and the extraction of waste and saleable by-products (Illus 21). The depiction

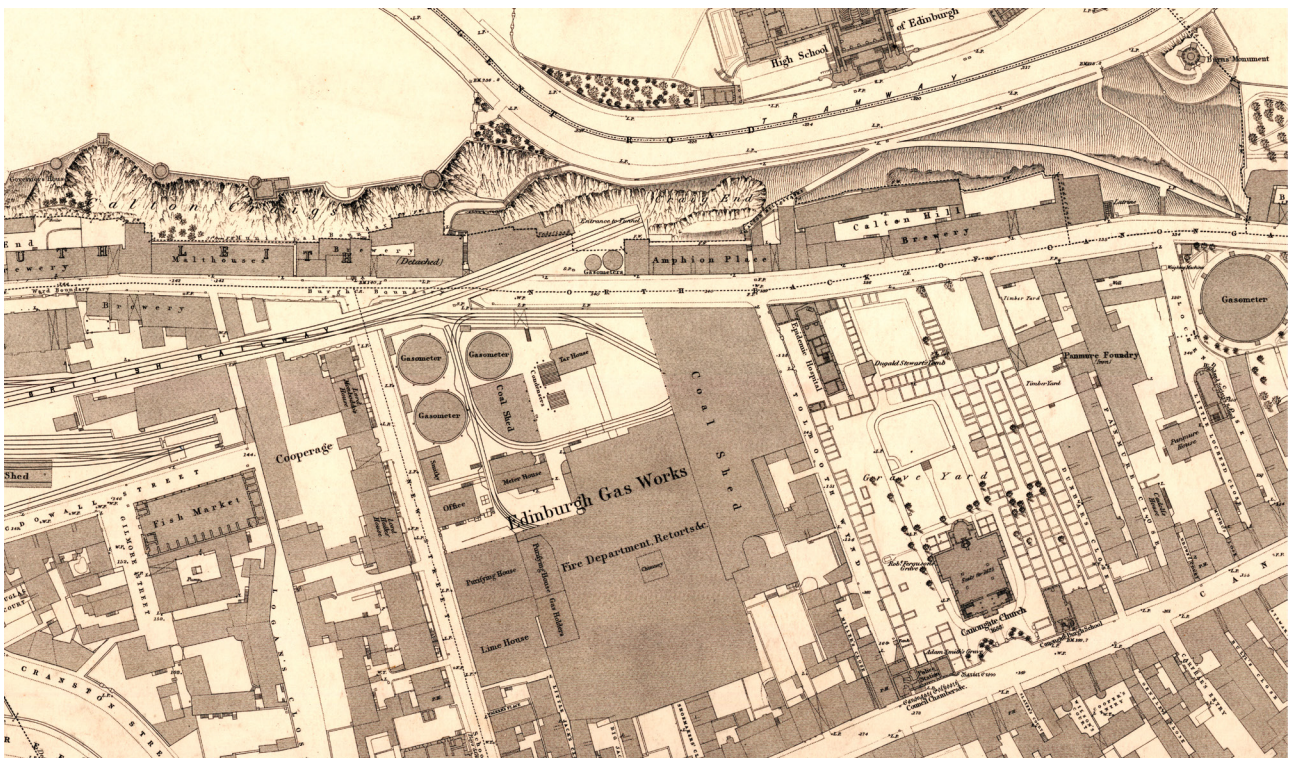

Illus 20 Ordnance Survey 1881 (Revised 1877) *Edinburgh* Sheet 30, scale 1:1056 (Reproduced with the permission of the National Library of Scotland and under Creative Commons (CC BY 4.0))



Illus 21 The coal shed in operation prior to demolition (© HES)



Illus 22 Above-ground piping of the New Street condensers prior to demolition (© HES)



Illus 23 Detail from Ordnance Survey 1895 (Surveyed 1894) *Edinburgh* Sheet III.8.12, scale 1:500 (Reproduced with the permission of the National Library of Scotland and under Creative Commons (CC BY 4.0))

of stairways illustrates that the Gasworks operated on different levels. The layout of the buildings in the north of the Gasworks has altered somewhat by the late 1870s. The works has been joined by two additional gasholders (annotated as gasometers) to the north-west side, one of which necessitated the partial removal of the adjacent coal shed (Illus 20). A smithy has also been erected to the south of the westernmost gasholder. The ‘Condensers’ (Illus 22) now occupy a more central location,

adjacent to the ‘Tar House’. The western of the two north/south-aligned blocks, visible on mapping since at least 1821, are still present.

The date of extension of the coal shed, at the corner of the North Back of the Canongate and Tolbooth Wynd, the area formerly occupied by the foundry, is indicated by a plan dated October 1874 (HES EDD 747/5).

The 1894 (published 1895) Ordnance Survey mapping (Illus 23) shows the Gasworks in the last

years of the 19th century, dominated by a single roofed area incorporating a chimney. It appears to have only one major gasholder, the edge of which is visible on Illus 23 to the north-west of the complex (the other two present in the 1877 maps appear to have been removed). The Ordnance Survey map of 1905 (published 1908) depicts the 'Old Gas Works', suggesting that the complex had already ceased to be functional by this time (Illus 24). An additional circular oil storage tank has now been built to the north of the existing holder on the 1894 map. Mapping of 1914 (not illustrated) depicts the area of the 'Old Gas Works' as largely unchanged from 1905, although the two gasholders to the north-west are not shaded and therefore likely no longer in use.

The division of activities in the Gasworks site prior to its demolition in the early 1900s is indicated in more detail on a plan of 1915 (Illus 9) (HES EDD 747/1). This shows that in the north-west of the site there were two circular tanks (as noted above), one for oil storage and the other a gasholder. Immediately east of these was an apparently unroofed area of 'Purifiers'. The offices of the Gasworks stood south of the tanks, on the western boundary of the site (as depicted on earlier maps) and incorporated a 'Meter House'. The major area of Purifiers was a rectangular 'Purifying House', divided into four areas (A to D) covering the south-west of the Gasworks. The largest roofed element of the Gasworks covered the central and eastern zone of the site and was

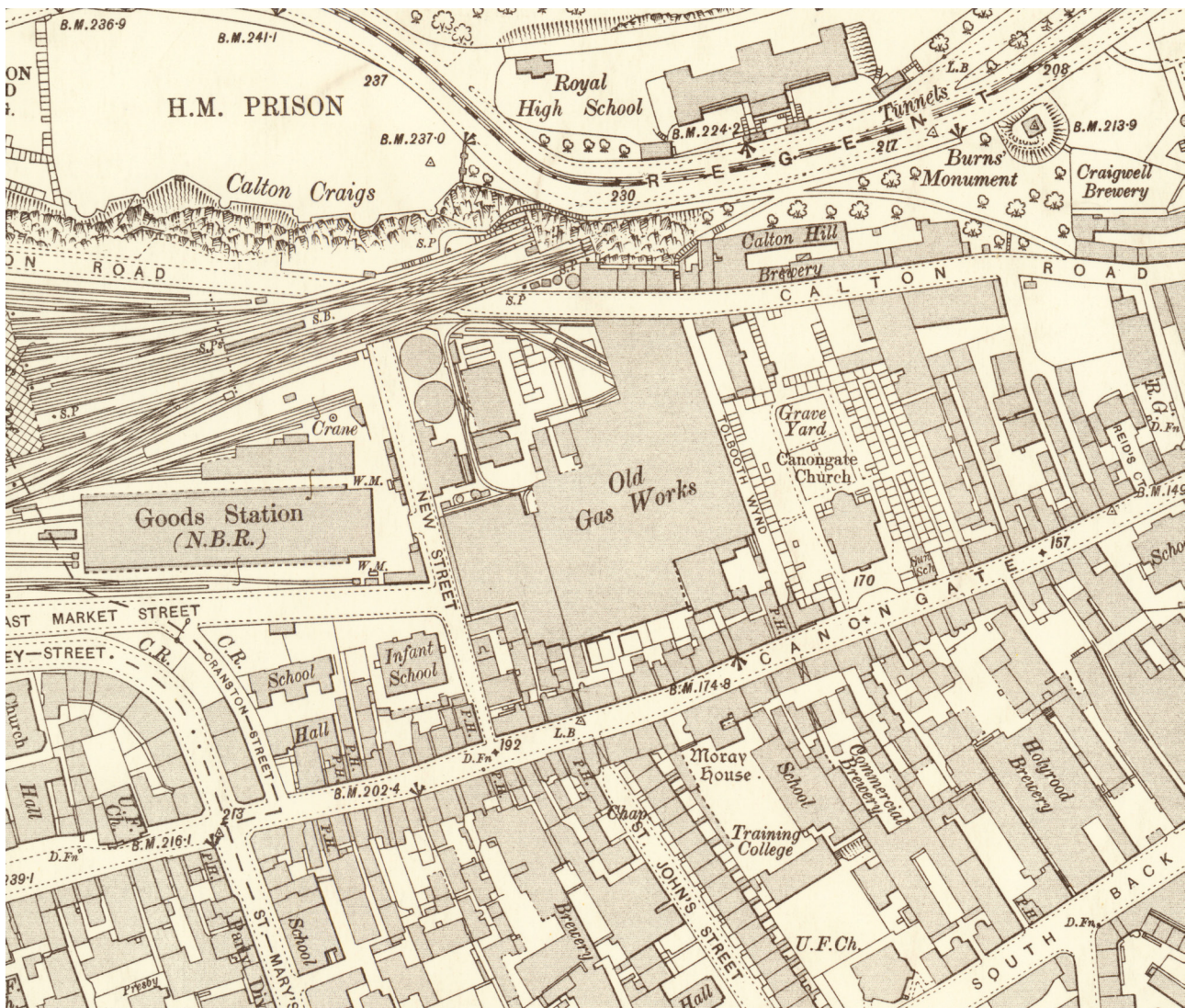

Illus 24 Detail from Ordnance Survey 1908 (Revised 1905) *Edinburghshire Sheet 003.08* (includes: Edinburgh), scale 25 inch to the mile (Reproduced with the permission of the National Library of Scotland and under Creative Commons (CC BY 4.0))

subdivided into areas E to J; it incorporated a small area marked 'No Roof Over This Portion', which appears to correspond with the site of the chimney on later 19th-century Ordnance Survey mapping. The north-west corner of this structure incorporated a Boiler House, south of a building labelled 'Power and Boiler House'. In the south-west of the Gasworks, accessed from Gladstone Court to the south, was a building divided into a Testing Shop (to the south) and an area labelled 'Meter', the largest still-surviving (2017) element of the Gasworks, while a smaller (still-surviving) building to its east was a 'Workshop' in a 'Pipe Yard'. A lack of clarity in labelling means that it is possible that the larger building was a 'Meter Testing Shop'.

4.6 The Gasworks and contamination

4.6.1 Problems with pollution

The production of gas from coal is a process that produces noxious by-products, and contamination of the environment was a major problem which dogged the New Street works throughout its operational life. In the early days of the Gasworks, it appears that 'by-products such as tar, ammonia and sulphur compounds were not processed or recycled and tended to be collected and dumped' (Adamson et al 2016: 189). As early as 1817, there were objections against 'the offensive smell of some of the products of the distillation' (Edinburgh Observer 1817: 6). By-products included 'a liquor impregnated with ammonia ... a portion of tar and carbonic acid ... and sulphuretted hydrogen ... driven off in the form of elastic fluids'. These impurities could be condensed out by passing the gas through a cold body of water, either mixing with the water or falling to the bottom of a vessel. In the earliest attempts at using gas commercially, all the by-products were collected together 'and from the extremely offensive smell of some of the substances, the operation itself, and the combustion of the gas thus prepared, were quite intolerable' (ibid: 27). Fears of such pollution led the 'inhabitants of New-Street, North Back of the Canongate [to bring] the subject under legal discussion, for the purpose of preventing the erection of the Gas Works ... as a public nuisance'. The dispute was settled by Lord Reston in 1817, who visited New Street and other established private works, deciding that 'the Works

alluded to were not to be regarded as a nuisance' (ibid).

However, by 1817 the various by-products could be collected separately and safely, 'the tar and ammoniacal liquor being received in close vessels, and the sulphuretted hydrogen combining with the water in another vessel connected with the apparatus, the two substances which give out the disagreeable odour are in this manner separated from the gas ... and thus every objection to it as a nuisance, on the score of the offensive smell, may be completely obviated' (Edinburgh Observer 1817: 27). The 'strong eggy smell' associated with gasworks came from the purifiers, where hydrogen sulphide was removed from the gas (Historic Environment Scotland 2017). In the early days of the industry there were two methods of purification of the corrosive carbonisation products, the 'cream' method, using water and quicklime purifiers, and the 'dry' method, using dry lime. The former led to the production of a noxious by-product, 'blue billy' as noted above, which appears to have found its way into Edinburgh's sewers in the 1820s (Cotterill 1980: 34).

Unfortunately, the smell and other polluting effects of the early Gasworks was not entirely dealt with. An anonymous representative of one of the competitors of the coal gas industry, the Oil Gas Works at Tanfield, wrote in 1828 a pamphlet on the *Nuisance in Coal-Gas Works* (Anon 1828). This partisan document sought to inform of the greater polluting effects on residential areas from coal gasworks in comparison with oil gas establishments. It cited people who lived in the vicinity of the Peter Street Gas-work in Westminster such as Mr A D Stewart, who noted that he was 'much annoyed by smell and smoke, proceeding both from the chimney and from parts of the work below the chimney; the smoke is equal to that from a brewery or distillery, and is often connected with a very offensive smell', indicating his intention to move out due to the effects on his family's health (ibid: 11–12). The anonymous author notes that 'the Edinburgh Coal-Gas Work, like those of London, must create similar annoyances to those who dwell in its vicinity, and occasion a similar depreciation of their property' (ibid: 21). A witness from Edinburgh, a Mr Thomas Meggat, Writer to the Signet, who lived in New Street until 1819, but then moved out to

Drummond Street, describes the impact of the coal gasworks on local residents which adversely affected both their health and the value of their properties. Meggat stated that ‘previous to the establishment of the works, New Street was inhabited by professional people and landed gentlemen – but after that period, the class of person inhabiting that street entirely changed’. He further notes that ‘this nuisance arose partly from the gas which escaped in drawing the retorts, and which ... was driven into the houses; and partly from the lime-water, used in purifying the gas, getting into the common drains, and coming up into every house’ (ibid: 22). He suggests that ‘since the establishment of the gas-work, every inhabitant of the respectable class, formerly living in New Street, has quitted it: that the property has been depreciated to at least one-fifth’, and notes his difficulty in selling his New Street property (ibid: 23). The tendency for people, if able, to leave the vicinity of gasworks was noted around the Gas Light and Coke Company’s works in Westminster and elsewhere as ‘gasworks filled their neighbourhoods with smoke and foul smells ... Over time, such localities became occupied almost exclusively by poor and working-class people’ (Thorsheim 2006: 140).

In the Act of Parliament facilitating the expansion of the Edinburgh Gas Light Company’s operations in 1829 it was indicated that pipes and other conduits for conveying gas were to be ‘laid at the greatest practicable Distance from the nearest Part of any Water Pipe ... for the Conveyance of Water’ (GD504/3/97/2: 5). This was backed up by a potential fine of up to £20 when gas contaminated the water supply, with an additional £10 fine for each day the water remained ‘contaminated, tainted, or affected by such Gas’ (ibid: 7). Additionally, escapes of gas were to be stopped by the company, with a fine to be imposed if this was not done within 24 hours (ibid: 8–9). The desire to avoid contamination led to the following statement within the Act:

If the said Company shall at any Time empty, drain, or convey, or cause or suffer to be emptied, drained, or conveyed, or to run or flow any Washings or other waste liquids, or any noisome or offensive Liquids, Substances, or Things whatsoever which will arise or be produced in The Gas Works of the

said Company ... into any River or Brook, or Running Stream of Fresh Water, Reservoir, Canal, Aqueduct, Feeder Pond, Springhead, or Well, or into any Drain, Sewer, or Ditch communicating therewith ... then and in every such case the said Company shall forfeit and pay for every such Offence the Sum of Two Hundred Pounds.

Additionally, the Company would cover the costs of such suits against them and was liable for a £20 per day penalty for not fixing the discharge of washings and waste liquids (ibid: 9–10).

A pamphlet of 1840 describes the polluting effects of the ‘Coal Gas-works in the Canongate’ on a watercourse, a ‘foul burn’ used for irrigation of agricultural land. The Gasworks is said to produce ‘an abundant stream, the odour of which is no doubt extremely offensive, being the most nauseous of all compounds. This flows into a principal feeder of the old foul burn at the south back of Canongate’ (Anon 1840: 8). The author laments that Canongate has ‘gradually ceased to be the fashionable end of town’ (ibid: 126). The pollution of watercourses by gasworks was a common issue as ‘derivatives that appeared to have no commercial value were often allowed to simply drain into the nearest stream or river’. This led in 1821 to one of the earliest episodes of gasworking-related water pollution in Britain, ‘when fish and eels in the Thames were reportedly killed’ (Thorsheim 2006: 141).

4.6.2 The wells

In 1821, the governors and directors of the Edinburgh Gas Light Company had reported that they were ‘in progress of securing a competent supply of water within their premises, which will be drawn from a pit-well by a small steam engine, and which is so constructed as to turn the lime-purifiers, whereby much manual labour and expence [sic] will be saved to the Company’ (NRS GD504/3/97/7: 1). It appears that the requirement for this new water supply was caused by contamination issues. Following a statement regarding ‘Actions of Damages against the Company’, where it is found that ‘certain of the pursuers [were] entitled to £650 of damages ... for deterioration of their properties’, it was noted that ‘considerable improvements’ had been made

to the ‘purifying-apparatus’ and that the company would soon be in possession of a ‘great command of water’ with ‘no reason in future to complain of the effluvia from the lime-water’ (ibid: 1–2). The steam engine was completed and operational by June 1822 and all lawsuits with claimants ‘(for deterioration of their property), from the operations of the Company [had been] fully settled by arbitration’ (NRS GD504/3/97/5: 1–2). This may have been the result of ‘stench from lime containing hydrogen sulphide which escaped into town sewers in 1820 [and] caused great opposition’ (Cotterill 1976: 244).

4.6.3 Contamination of brewery water supply

In its last years, ‘a series of contaminations occurred ... which affected the water supply for the breweries adjacent to the gasworks’ (Adamson et al 2016: 49). In 1890 ‘the chemicals involved in the production of gas were contaminating brewery wells’ (Dennison 2005: 137) and the Edinburgh and Leith Gas Commissioners were sued by James Muir & Son, who ran the Calton Hill Brewery in the North Back of Canongate, between 1905 and 1908. The Gasworks had contaminated the water supply for the brewery, rendering it unfit for use in brewing, and therefore damages were paid to sink new wells for the affected breweries (Thorsheim 2006: 142; Adamson et al 2016: 49). Muir’s Brewery was located to the north of the North Back of the Canongate, covering a large area east of Amphion Place, roughly adjacent to PA1(B) (see Appendix 1). It appears to have been a late occupation of the 19th-century Calton Hill Brewery (NRS GD283/6/233_a). Muir’s brewery was affected by the pollution of both the ‘Brewery Well’ and, earlier, the Stable Well; it was compensated £3,730 for pollution of the ‘Stable Well’ (NRS GD283/6/233_b: 1, 10 and 16).

4.6.4 The use of by-products at New Street

A means by which the negative properties of the commonly highly noxious contaminants produced as by-products in the gas industry could be turned to the good was in the reuse of the by-products, whether recycled as fuel or utilised in other industrial processes. From its earliest days the potential for utilising by-products such as ammonia and coal tar was recognised in the Act

of Parliament of 1817 by which the New Street Gasworks was set up, where it was stated that ‘Coke may be beneficially employed as fuel’ while ‘Oil, Tar, Pitch, Asphaltum, Ammoniacal Liquor and Essential Oil, may be used and applied in various other ways with great Advantage’ (NRS GD504/3/97/14: 1–2).

In 1817, the ways in which impurities were dealt with were described as the New Street Gasworks was being constructed (Edinburgh Observer 1817: 27). This notes that:

the different products of the distillation are collected in separate vessels before they reach the gas-holder. The tar and the ammoniacal liquor are conveyed along cast iron tubes of considerable length, in which they are condensed, and received in a proper vessel; the carbonic acid or fixed air and the sulphuretted hydrogen pass along the tubes to another vessel, where they are absorbed by lime water; and thus freed from the different ingredients from which the offensive smells proceed, the carburetted hydrogen is admitted to the gas-holder, from whence it is distributed for the purposes of combustion.

At New Street, from at least 1819, the coal used for the retorts was described as producing coke that ‘appears to be excellent but as we consume it in our own Furnaces we cannot distinctly state how it might answer others’ (NRS GD1/1246/1_b). The coke produced in the retorts was thus recycled within the New Street works itself and was not sold on. Cotterill notes that from around the 1840s the use of another by-product, tar, as a furnace fuel was developed (Cotterill 1980: 25), and this is likely to have been used at New Street.

Prior to this, in May 1824, by-product tar was supplied by New Street for rubber production as ‘Edinburgh gas company signed a contract for twelve years supply of tar to Dr John Wilson Anderson of Edinburgh, for whom [Charles] Macintosh stood as security’ (Cotterill 1976: 545). An extra market for naphtha opened up in Edinburgh in 1856 when the North British Rubber Company purchased the former Castle Silk Mills to begin the production of cheap rubber shoes (ibid: 549).

4.7 Working conditions and the labour force

While Albert Winsor is said to have claimed in the early 1800s that ‘he had cured himself of a constitutional asthma by superintending the work at his stoves, and inhaling the “hydro-carbonic gas”’ (Hunt 1907: 101), the atmosphere of a gasworks plant was not salubrious. According to a handbook of 1878 quoted by Thorsheim, sulphuric acid fumes filled the retort houses which ‘could eat through unprotected iron’, and ‘even galvanized nails had to be coated with tar to prevent their being “rapidly destroyed by the action of the gases and vapours”’ (Thorsheim 2006: 139–40).

Thorsheim quotes Will Thorne, a Labour MP who had worked at the Saltley gasworks in Birmingham, as stating that work in the retort house ‘was hot and very hard. As the coke was drawn from the retort on to the ground, we threw pails of water on it, and the heat, both from the ovens and the clouds of steam that would rise from the drenched coke was terrific’ (Thorsheim 2006: 138). The job of a gasworks stoker was ‘hot, dirty and dangerous’, and ‘due to the heat they worked with the minimum amount of clothing on, shirt, trousers, gloves and clogs, plus a cap’ (Bird & Nabb 1989: 51).

It appears that the Edinburgh Gas Company by the late 1800s had recognised the health of its workforce as an issue to be addressed, as in 1881 ‘John K Watson, Esq Manager Edinburgh Gas Light Company’ is listed in an advertisement as one of the directors in Scotland of a newly formed company called ‘The Employers’ Liability Assurance Corporation (Limited)’. This assurance company had been set up as a reaction to the Employers’ Liability Act, 1880 as ‘Employers of labour of every description, from and after the 1st day of January, 1881, are held liable to make compensation for personal injuries suffered by workmen in their service ...’ (Capital and Labour 1881). The risks in coke plants and gasworks included lost limbs, crush injuries and burns; in 1930 it was recorded that ‘over half of the “notifiable causes of cancer” in Britain resulted from exposure to by-products created by the carbonization of coal in gasworks and coke ovens’ (Thorsheim 2006: 138). Other health problems present in gasworkers even as late as the

1950s included ‘eczema, warts and melanoma’ (ibid: 140).

Cotterill has analysed the 1861 census to identify the number of ‘Gasworks Services Employees’, including managers, stokers, labourers, etc, across Scotland and found that there were 222 individuals employed in this trade in Edinburgh that year (Cotterill 1976: 688). The various gasworks employees in Edinburgh in 1866 included: Gas Maker (Foreman); Stokers; Retort Men; Coke Men; Engineers; Joiners; Bricklayers; Smiths; Pipe Layers; Gas Fitters and Labourers (ibid: 704). In part, workers’ wages reflected the conditions and skill needed in the work undertaken, with ‘retort men’ paid considerably more than ‘barrow men’ or ‘yard men’. In 1873, for example, the retort workers earned 7½d or 6d per hour; barrow men 6d, and yard men 5½d (ibid: 697–8). Stokers were viewed as a semi-skilled workforce as ‘experience was important in obtaining a high yield of gas from the coal ... The retort house workers came to be regarded – and paid – as semi-skilled operatives rather than general labourers’ (Bird & Nabb 1989: 3–4).

The National Union of Gas Workers and General Labourers of Great Britain was formed in March 1889 when ‘the first effective attempt was made to organise gas workers’. The union ‘grew out of a mass meeting held at Canning Town, London’, where a reduction in shifts from 12 to 8 hours was secured (Bird & Nabb 1989: 3). The 1880s saw industrial agitation in Scotland as workers at the Edinburgh Gasworks ‘threatened to walk out in September 1888 because of bad working conditions and excessive heat’ (ibid: 720). Agitation grew in ‘Glasgow, Edinburgh, Leith, Greenock and Perth’ in 1889 for better working conditions, shorter hours and better wages. Ultimately, branches of the National Union of Gas Workers were opened in both Edinburgh and Glasgow in 1891, and Edinburgh Gasworks saw shifts shorten from 12 to 8 hours in 1890 ‘without altering wages’ (Cotterill 1980: 23). However, agitation among stokers for shorter hours and higher wages acted as an impetus for their replacement by machinery (Cotterill 1980: 23), perhaps ultimately being a factor in the replacement of the New Street works by those at Granton.

4.8 Survival of Gasworks structures

Cartographic and bibliographic sources indicate that two of the buildings that occupy a site at 179a Canongate, Edinburgh are late 19th century/early 20th century in date and were associated with a late extension of the New Street Gasworks, confirmed by historic building assessment undertaken in 2017 and 2018. These structures were identified as a large courtyard building of 1877–94 and a smaller workshop building of 1894–1908 (Bradley-Lovekin et al 2018: 6–7; Bradley-Lovekin et al 2019: 5). Adamson et al (2016: 47) note that ‘part of the gasworks’ boundary to Old Tolbooth Wynd survives and is seen in the arched brickwork of the boundary wall here. Other buildings have been reused for later industrial purposes, and some have been incorporated into modern developments along Old Tolbooth Wynd’ with a ‘range of recessed arched blind openings in a brick wall’ also visible on the west side of Old Tolbooth Wynd (ibid: 151), part of the eastern boundary of the Gasworks (Illus 25).

The larger surviving (courtyard) building of the Gasworks is located in an area behind the Canongate frontage, which is depicted as being in part covered by a ‘Bowling Green’ on Edgar’s map of 1765 (Illus 5). The historic buildings assessment of 2018 ‘identified a number of upstanding walls that appear to represent structural survivals from the buildings which preceded the gasworks’ (Bradley-Lovekin et al 2019: 33). These earlier wall features were ‘limited to the lower portions of the eastern external wall of the 1877–1894 [courtyard] building ... and the eastern part of the of northern boundary wall [of the courtyard area] ... although they are fragmented and with the exception of the probable fireplace within the northern boundary wall, hard to interpret’ (Bradley-Lovekin et al 2018: 23).

In this area, Robert Kirkwood’s plan of 1817 and James Kirkwood’s plan of 1821 (Illus 6 & 7) both depict a building that may be the lodge of the ‘Magdalene Asylum’ (Canmore ID 133031). On the Ordnance Survey map published in 1852 (Illus 8),



Illus 25 Blind openings in eastern external wall of Gasworks on Tolbooth Wynd

the area behind the Canongate frontage buildings at the corner with Tolbooth Wynd is occupied by gardens, likely the former bowling green depicted by Edgar, and a 'Lodge' associated with the Magdalene Asylum, as well as, to the east adjacent to the wynd, buildings and unroofed enclosures or yards accessed from Miller's Close. The Ordnance Survey map of 1877 (Illus 20) indicates that the former 'Lodge' of the Magdalene Asylum was still apparent (though unlabelled) in a still relatively undeveloped area, while to the east, against Tolbooth Wynd, buildings and yards were accessed from Miller's Close. The Ordnance Survey map of 1895, surveyed 1894 (Illus 23), indicates that the structures earlier present around Miller's Close had been removed, likely as a result of it being overbuilt by structures associated with the Gasworks to the north, from where a group of rail tracks can be seen to exit the large main building of the Edinburgh Gas Works. To the west, the formerly open area south of the former location of the asylum is covered by a large unlabelled building, again apparently associated with the Gasworks; it is also present on later (20th century) Ordnance Survey maps of 1908 (Illus 24), 1914 (not illustrated) and 1931 (not illustrated). This is the larger of two still-surviving buildings of the Gasworks. Ordnance Survey mapping of 1948 (not illustrated) shows the large (surviving) Gasworks building visible since 1894 with two smaller structures to its north-east, potentially all late elements of the Gasworks. Present-day mapping shows the large building visible on late-19th-century maps to still be present, as is one of the late-19th/early-20th-century buildings to its north-east. A more recent rectangular building is also present, identified as a 1980s extension to the courtyard building during standing building assessment works (Bradley-Lovekin et al 2017: 25; Bradley-Lovekin et al 2018: 19).

The large late-19th-century building, and the smaller late-19th/early-20th-century building, constitute the only substantial surviving roofed elements of the Gasworks, though surviving walls can also be found along the west side of Tolbooth Wynd, sometimes incorporated into later developments. According to Adamson et al (2016: 160), 'the four- and six-storeyed development at the foot [north] of Old Tolbooth Wynd' incorporates material from the former Gasworks (and the earlier

Canongate Foundry). Additionally, an east/west running southern wall of the former Gasworks site exists as a patchwork wall of brick and stone, photographed by the RCAHMS in 2014 (HES DP 207861 – DP 207863), as well as a boundary wall north of the buildings at 179a Tolbooth Wynd (HES DP 207866 – DP 207867). The building recording works of 2017 and 2018 identified that 'the central and western parts of the ... boundary wall, in all probability originated as the northern boundary of an intermediary post 1877 expansion to the gasworks, although the original core of the gas works was located to the northwest beyond the Magdalene Asylum' (Bradley-Lovekin et al 2018: 22). The various boundary walls of the courtyard have several phases of build. The boundary wall on its east side 'has a set of quoin stones marking an original entrance ... presumably creating access to and from the gasworks site ... This has been infilled with brick on the internal side' (ibid: 20). An entrance through a brick wall from the south of the courtyard building of 179a Tolbooth Wynd (HES DP 207855) was also identified by the RCAHMS as a gateway leading into the site of the Gasworks; also photographed was the smaller surviving building (HES DP 207864 – DP 207865).

The function of these surviving structures is indicated by a plan of the New Street Works, by Alexander Masterson, dated February 1915 (Illus 9), shortly after the works had ceased activity (HES EDD 747/1). This indicates that the smaller structure functioned as a 'Workshop', while the larger building was divided into an area labelled 'Meter' to the north, and a 'Testing Shop' to the south; it is possible that the larger building was actually a 'Meter Testing Shop'.

The large surviving courtyard building takes the form of west, north and east ranges set around an unroofed courtyard, with a wall to the south enclosing it; mapping evidence indicates that the central courtyard area was once roofed. It is constructed of 'dark red brick in an English Garden Wall Bond' and is approached from the south 'through a large archway ... from Bowling Green Close, which is located between Nos 177–183 Canongate' (Bradley-Lovekin et al 2017: 25). Also noted was that the 'interior of the building' retained 'little of its original character and [its] internal layout ... with the addition of



Illus 26 Workshop building from the south-east

stud partition walls, gantry stairs and replacement windows’ (Bradley-Lovekin et al 2018: 16). The smaller, workshop, building to the east (Illus 26) is recorded as abutting the courtyard building at its northern end. It is described as ‘a three-bay by two-bay double height building constructed of a lighter beige brick than its neighbour in an English Garden wall bond’. Of interest is that ‘the rear wall of the building has incorporated another older wall into its build ... with the brick patching to consolidate the stone wall in the internal north-west corner of the courtyard ... The rear north elevation then shows the upper part of the building over the earlier stone building with a thin central chimney’ (ibid: 18).

4.9 Scottish Motor Traction

Ordnance Survey mapping of 1931 (not illustrated) depicts the Scottish Motor Traction (SMT) ‘Bus Depot’ covering much of the former Gasworks area. This depot was built as a garage to accommodate and maintain 300 buses on two floors for the Scottish Motor Traction Company. This was ‘the largest private bus company in Scotland, operating in its own name and through its ownership of W Alexander and Sons, Central and Western SMT ... by the 1930s it had around 2,500 buses’ (Knox 2014: 7). SMT had purchased the site by 1926 (Edinburgh Corporation 1926: 17) and the bus depot on New Street was constructed in 1928 and

extended around 1934 (Adamson et al 2016: 46).
A contemporary account notes:

the Scottish Motor Traction Co., Ltd., of Edinburgh, which not only maintains a vast network of motorbus routes in the south-eastern portion of Scotland, but also carries out pleasure tours on a very extensive scale from the Scottish capital, has recently still further improved its big organization by opening an extensive new garage and depot, probably the largest in the kingdom ... the company has had constructed a garage providing 90,000 sq. ft. of floor space, and having adjoining it a site nearly half as large as this area for developments which

may become necessary. (Commercial Motor 1928)

This development formed part of the Canongate Improvement Scheme of 1930–1 under the City Architect, Ebenezer James MacRae (Adamson et al 2016: 17, 22). The garage originally covered only part of the former Gasworks, but a plan of 1935 shows that the original SMT garage of 1928 was then planned to be extended to the north, an area formerly covered by circular storage tanks (HES DPM 1930/195/1/3). The garage became the SMT's main depot when one at Fountainbridge closed but by the mid-1990s had ceased to function as a depot and saw use as an indoor market (Mullay 1996: 133).

5. PREVIOUS ARCHAEOLOGICAL WORKS

There have been extensive works in the area of the New Street Gasworks. An archaeological watching brief identified 19th-century foundations (McCullagh & Gooder 1999), while an archaeological evaluation in 2000 identified a buried cultivation soil, containing ceramic artefacts dating between the 12th and 18th centuries (Gooder 2000). Excavation in late 2000 revealed buried garden or cultivation soils, with associated features, with artefacts indicating activity in this area from the 12th century AD onwards (*ibid*).

An archaeological evaluation at the former New Street Bus Depot after its demolition to floor slab level identified probable medieval/post-medieval buried soils, truncated by construction of the 19th-century gasworks; a subsequent watching brief identified remains of this gasworks (Engl et al 2006). Excavation and watching brief works at the New Street Bus Depot also recorded the remains of the former Edinburgh Gasworks and pockets of post-medieval soils (Wilson 2007; 2008f). AOC Archaeology Group has undertaken several further investigations in the area of the Caltongate Development (eg Wilson & Toolis 2008a; 2008b; Sproat & Toolis 2008; Engl et al 2013).

At the Tolbooth (located on the Canongate), excavation of the cellar area in 1988 uncovered floor layers and a number of cut features of varied date, including construction pits; a clay-lined water-tub; a wooden tub sunk into the floor, and part of a stone drain. A range of post-medieval pottery was recovered, including part of a mounted figure in glazed ceramic, dated to the later 16th century (Holmes 1988).

To the east of the Gasworks and Tolbooth Wynd, at 20 Calton Road, there have been several phases of archaeological work, including excavations in 2013 and 2014 associated with the PA1(C) area of the New Waverley development (Wilson 2008d; Engl forthcoming), revealing evidence from the initial cultivation of the Canongate 'backlands' in the 12th/13th centuries to the construction and subsequent development of the Canongate Poorhouse. A sequence of buried garden soils/middens relating to pre-18th-century activity was recorded, in addition to remains of a single burgrave

plot boundary and associated rig and furrow deposits. Burial remains relating to the graveyard of the Canongate Kirk, dating to between 1688 and 1775, were also recorded. These excavations represent an area on the periphery of the medieval Canongate Burgh, which remained in open cultivation from the 12th/13th century until its conversion into more formal use between the 14th and 17th centuries with the creation of burgrave plots. In this area, a lack of features typical of 'backland' activity and the presence of imported ceramics show that the Canongate remained the preserve of Edinburgh's wealthy mercantile elite until the economic decline of the mid to late 17th century. The Poorhouse, built in 1761 over the north edge of the Canongate Cemetery and used in the early 1870s as an epidemic hospital, was found to contain at least two phases of construction (Engl forthcoming). The results of archaeological works in areas PA1(A) and PA1(B) of the New Waverley development, where late post-medieval structures and deposits were recorded, are detailed in Appendix 1.

To the west of the former Gasworks site, archaeological works associated with the development of a hotel as part of the New Waverley development at East Market Street identified 'a substantial ditch feature likely relating to previously excavated ditches in the medieval burghs of Edinburgh and Canongate' (Lowther 2018: vi). Waterlogged deposits facilitated the survival of artefactual remains associated with two phases of this defensive feature – the late 12th–13th century when it was constructed and the latter half of the 15th century when it fell out of use (*ibid*). To the south-east of the Gasworks, Headland Archaeology undertook archaeological works at the 19th-century brewery of 160 Canongate/Sugarhouse Close/41, 49, 53 Holyrood Road (Wilson 2012). These archaeological works recorded multiple layers of garden soils, possibly associated with medieval and post-medieval activity. A large well was also recorded, perhaps the earliest feature on the site, and the remains of two stone walls may represent the location of a sugar refinery that existed on this site between 1752 and 1853 (*ibid*; Canmore ID 135131).

6. THE EXCAVATED EVIDENCE: NEW STREET GASWORKS

6.1 Introduction

The archaeological works across the site of the former Gasworks aimed to fully record archaeological features surviving below the former New Street Bus Depot (Illus 2).

The excavations in the centre and south of the site revealed substantial remains of brick and sandstone walls and other structures, which relate to the 19th-century New Street Gasworks complex (Wilson 2008e; Illus 27). In addition, truncated pre-Gasworks buried garden soils (Phase 1) were also recorded. Three major phases of Gasworks activity (Phases 2–4) were identified through comparison of the archaeological evidence and cartographic records. These included substantial stone walls associated with the early Gasworks from around the time of its incorporation in 1818 to its redevelopment *c* 1845 (Phase 2). Features of the expanded mid-19th-century Gasworks (Phase 3) were also recorded although the majority of features were associated with the final period of the Gasworks' active life (Phase 4), between *c* 1875 and 1906. The results of these works permit the examination of the development of the Gasworks across almost a century, with the introduction of a wide range of technological innovations.

Subsequent works on the Caltongate North site comprised a series of archaeological watching briefs and an archaeological excavation, which identified further significant features associated with the Gasworks (Wilson 2008a; Illus 28). Archaeological monitoring also revealed further isolated pockets of post-medieval backland soil and sandstone walls.

6.2 The fieldwork of 2006–2008

6.2.1 Caltongate South site

The area covering the centre and south of the former New Street Bus Depot and earlier Gasworks was excavated between 2006 and 2008 using a mechanical digger with hand excavation of significant features. Excavation 'Areas' were generally defined along the boundary lines of distinct features such as long walls or drainage gullies. These Areas were labelled from A to P, with corresponding context numbers

(eg A0001, A0002, etc). Features including walls, floors and significant structures were subject to a full programme of archaeological recording aided by a programme of laser scanning.

6.2.2 Caltongate North

In the area covering the north of the former Gasworks, the ground was commonly found to be contaminated, resulting in the opening of a series of test pits and monitored ground reduction works between July 2007 and May 2008 (Illus 28). This exercise identified fragments of stone walls, confirming the results of an earlier evaluation of the area (Engl & Bailey 2006). Excavation was then undertaken of any areas of in situ backland soils and associated features that would be impacted by the future development works, while all walls, floors and features associated with the New Street Gasworks were recorded.

6.3 Results of the fieldwork: overview

Documentary and cartographic evidence suggest that there were six main phases (1–6) of activity in the area of the New Street Gasworks. However, due to the truncated nature of many of the excavated features and deposits, and the complexity of this largely industrial site, the assigning of many of the smaller and isolated features to a particular phase is problematic.

The initial phase (Phase 1) covers the period prior to the development of the New Street Gasworks in 1818. Phase 2, dating from 1818 to *c* 1845, saw the construction of the original buildings and structures of the Gasworks. Phase 3, dating from *c* 1845 to *c* 1875 was marked by the later expansion of the Gasworks, including the construction of a massive chimney and new buildings. Further expansion occurred in Phase 4, dating from *c* 1875 to 1906, including construction of a new coal shed to the east and an extension of the main Gasworks building to the south. The Gasworks closed early in the 20th century and was subsequently demolished, with part of the area used as a football pitch. This period, between 1906 and 1928, is Phase 5. The final phase (Phase 6) saw the construction of the New Street Bus Depot in 1928.

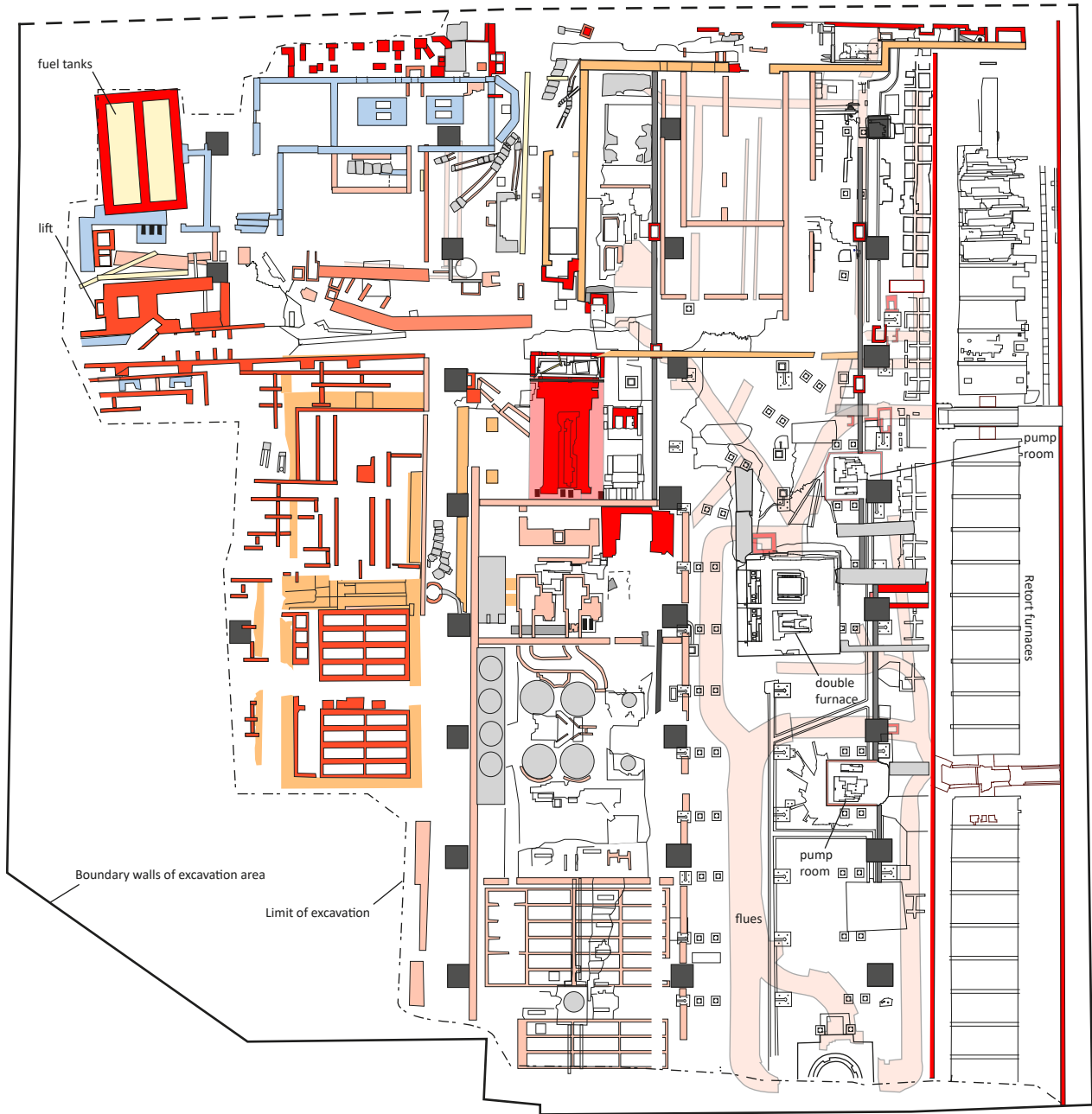

Key	
■	Stone walls with slate fragments
■	Sandstone walls
■	Etna and yellow brick walls
■	Red brick walls
■	Concrete
■	Capstones
■	Bus depot roof foundations
■	Cast iron features and pipes



Illus 27 Plan of Caltongate South excavation

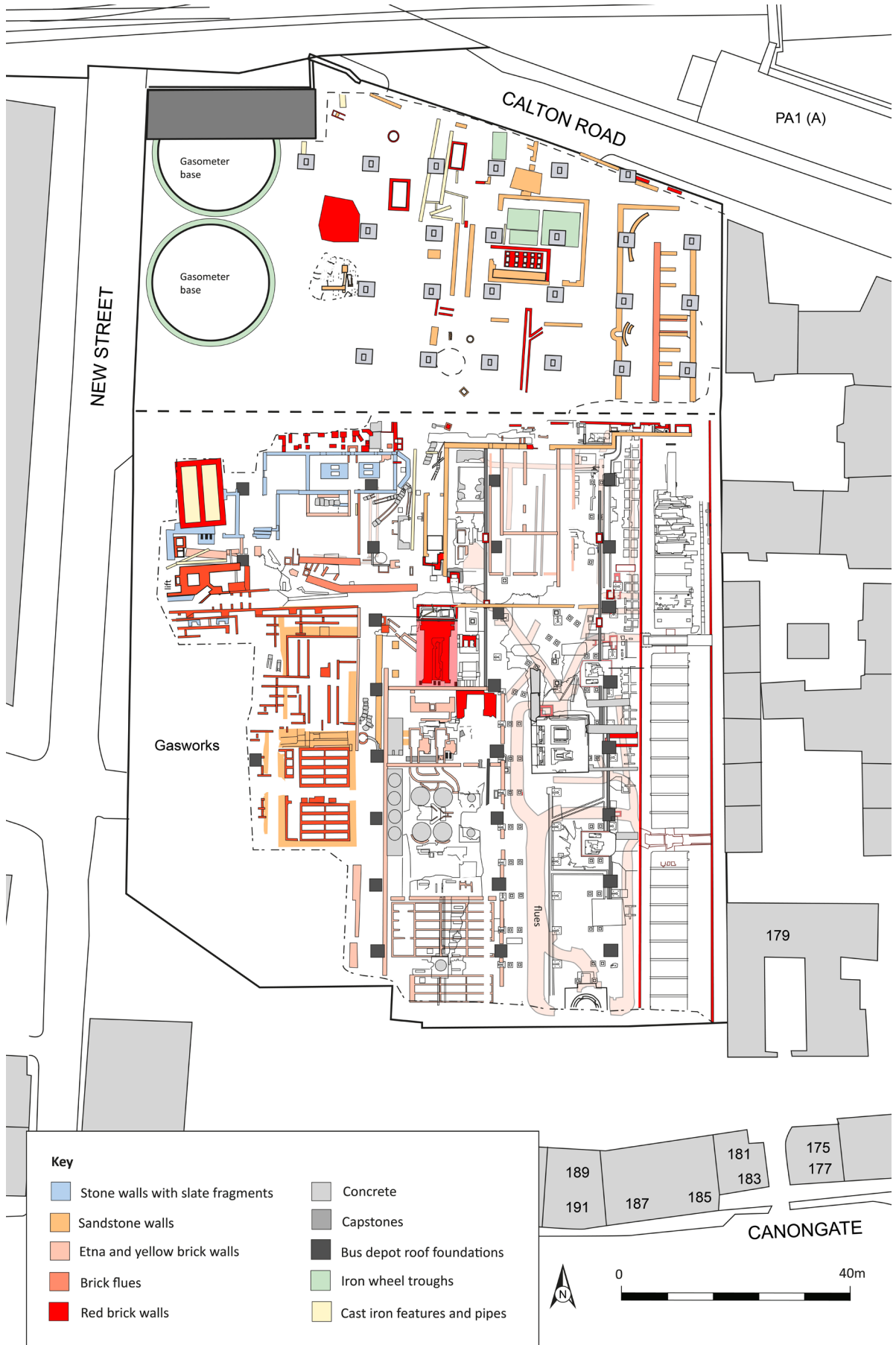

Illus 28 Plan of Gasworks excavations including Caltongate North

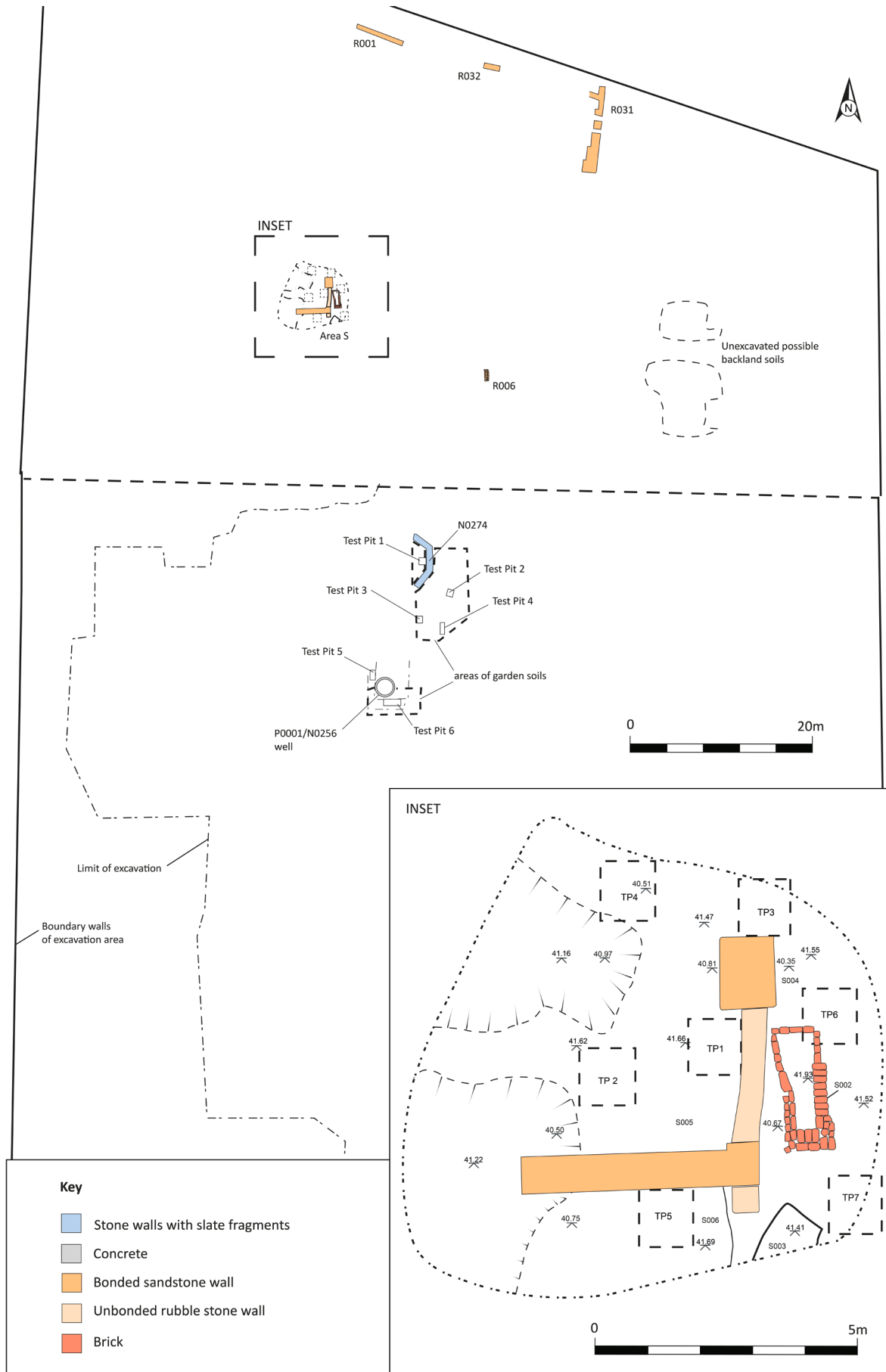

Illus 29 Plan of Phase 1 features

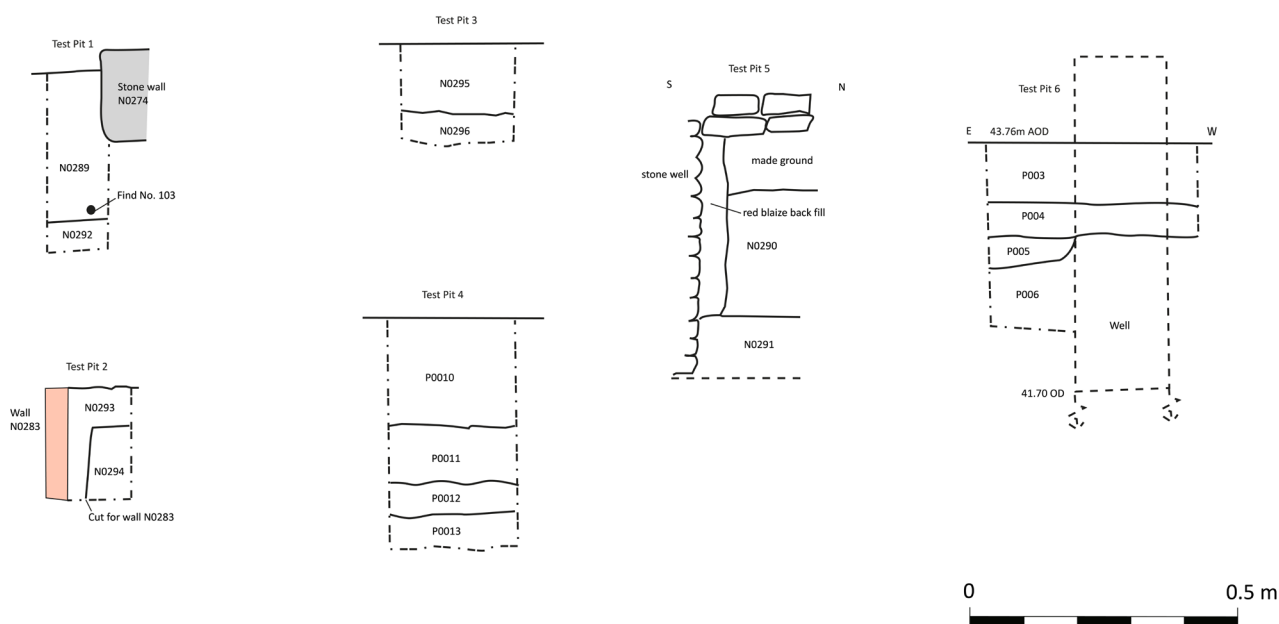

Illus 30 Sections through test pits showing Phase 1 garden soil deposits

6.4 Phase 1 (before 1818) (Illus 29 & 30)

Few features and deposits pre-dating the Gasworks survived, due to the truncation caused by its construction. This was particularly evident across the south of the former Gasworks area where this truncation had reached the natural geology. Only in small isolated pockets of the northern half of the site did any pre-Gasworks archaeology survive.

Two distinct layers of garden soil were recorded in four of the six test pits excavated in the east of the main excavation area of Caltongate North (TP1, TP2, TP3 and TP5) while three layers were visible in the other test pits (TP4 and TP6). The upper layer (N0289/N0290/N0293/N0295/P0003/P0010) was a dark brown silt, disturbed in places. Below this was a depth of between 0.10m and 0.50m of brown clayey silt (N0291/N0292/N0294/N0296/P0004/P0011) with occasional ceramic sherds. In TP4 and TP6 a layer of lighter brown clay/sand (P0005, P0012) was recorded above natural alluvial deposits. Two structures in this area were of potential Phase 1 date. A stone-lined well measuring 1.96m in diameter and 3m in depth (N0256/P0001) was cut through these deposits although its date is unclear. It could potentially be connected with attempts by the Gasworks to minimise contamination of

water flowing to the Calton Hill Brewery near the Gasworks, and therefore it may belong to a later phase (Illus 31). To the east of the well, a wall (N0274) was discovered which could also potentially pre-date the Gasworks (Illus 32). This short section of lime mortar-bonded rubble wall was cut into garden soil (N0289) and was interpreted as a possible foundation or lower element of a window bay, perhaps associated with one of the buildings known to have stood in the Canongate backlands in the post-medieval period.

Further north, one of the isolated areas of surviving backland soils, Area S, associated with the post-medieval occupation of the area was subject to intensive archaeological excavation as it would be disturbed by the development (Illus 29). Remains of structural features in this area could relate to buildings that occupied the area prior to the Gasworks.

6.4.1 Backland soils

Distinct zones of backland soils (S004)–(S006) were recorded, together with the remains of stone walls, (S001), (S007), (S008) and (S009). Finds from these deposits included fragments of pottery, clay tobacco pipe and glass. Charred cereal grain was found in low concentrations, in particular in two



Illus 31 Stone well (N0256) cut through the garden soils and alluvial deposits

test pits in this area (Test Pits 2 and 3). Animal bone (including fish bone), oyster shell and whelk, likely from domestic food refuse, were also recovered.

Deposits (S004) and (S005) were dark brown clayey silt garden soils, approximately 1m in depth. Below the backland deposits were natural alluvial deposits, generally between 40.58 and 40.97 AOD. Backland soils identified in the south of Area S, (S006), may have been redeposited. Further isolated areas of possible backland soils were present to the east (Illus 29), although these were left in situ as they would be undisturbed by the ground reduction works.

6.4.2 Structures within the post-medieval backlands

Two segments of stone wall, (S001) and (S008), (Illus 29 & 33) were cut through the backland soils in Area S. A lime mortar-bonded wall (S001) was aligned east/west (turning to the north at its east end) and survived for a length of 4.5m and to a maximum height of 1.1m. A further small section of wall (S008) was recorded 2.5m to the north, perhaps a pedestal for an arched opening. Between these two areas of wall was unbonded rubble blocking (S009). A small section of similar unbonded wall, (S007), abutted the south side of wall (S001). These



Illus 32 Remains of a stone wall (N0274) from the north

walls would have stood in the vicinity of a large building depicted on Kirkwood's map of 1817 (Illus 6) and could have formed elements of a building or boundary wall.

6.4.3 Other structural remains

Remains of several other stone structures may also represent buildings visible on historic maps of the area prior to the Gasworks. A stone wall with window bays (R001), located near Calton Road, was probably of pre-Gasworks construction. The base of wall (R001) was aligned north-west/south-east behind Calton Road. A 6m long section, up to

1.04m high, of this lime mortar-bonded rubble wall survived, with the bases of two window bays evident, 1.8m apart. Further small sections of wall base to the south-east, (R032) and (R031), could potentially have been continuations of (R001). A length of 8.7m of wall (R031) survived, aligned north/south. Although pre-Ordnance Survey maps lack detail, it appears that these walls, and the above-mentioned walls, (S001) and (S008), were not contained within the Gasworks until the expansion of *c* 1845. Buildings are depicted in the approximate location of (R001) and its related features, fronting on the North Back of the Canongate (Calton Road) on



Illus 33 View of stone walls (S001) and (S008), taken from the south-east

several 18th-century maps, most clearly on Kincaid's map of 1784 (Illus 3), where buildings also fronted the newly created New (or Young) Street. To the south, an area of cobble surface, (R006), possibly the remains of a field drain, was located 2m to the west of a stone-lined well (R002), which was likely associated with the Gasworks, though potentially also pre-dating them (see Phase 3 below).

6.5 Phase 2 (1818–c 1845) (Illus 34)

6.5.1 The parallel buildings

A series of substantial stone walls were recorded in Area K/N, together forming large stone-floored rooms, delimiting two large parallel areas, each divided into at least two main rooms (Illus 35). These parallel buildings are visible in this location on Kirkwood's map of 1821 (Illus 7) and on the Ordnance Survey map of 1852 (Illus 8); these would be occupied by 'Gas Holders', apart from the southern room of the western building, the 'Purifying House'.

To the south-west of Areas K/N, remains of lime mortar-bonded rubble walls were uncovered outlining a room, 9m in width (east/west) and 15m

long (north/south), truncated by later Gasworks construction. Wall (N0084) formed this building's southern boundary while (N0085) stood to the west, (N0039) and (N0038) to the east, and (N0021) to the north. A 1.6m wide gap separated the eastern wall segments, and a series of beam slots were visible on (N0039), which was built into the bedrock. The outer side of the wall was covered in a substantial grey clay cladding, possibly used as a sealant. These walls surrounded a substantial floor (N0083), of roughly dressed stone blocks. During Phase 4, this room was filled with a series of brick cells. The west wall, (N0085), had a maximum height of 2.77m and beam slots were visible in its south end, 2.4m above the floor, while two further beam slots were visible 1.57m above the floor to the north.

A 0.28m thick clay cladding separated wall (N0021) from parallel stone wall (N0020) to the north. This formed the southern end of the second large room of this structure, again measuring approximately 15m by 9m. In a similar fashion to the southern room, the 1.2m thick rubble walls of this room enclosed a stone floor, (N0077). The west wall, (N0110), had been truncated by later

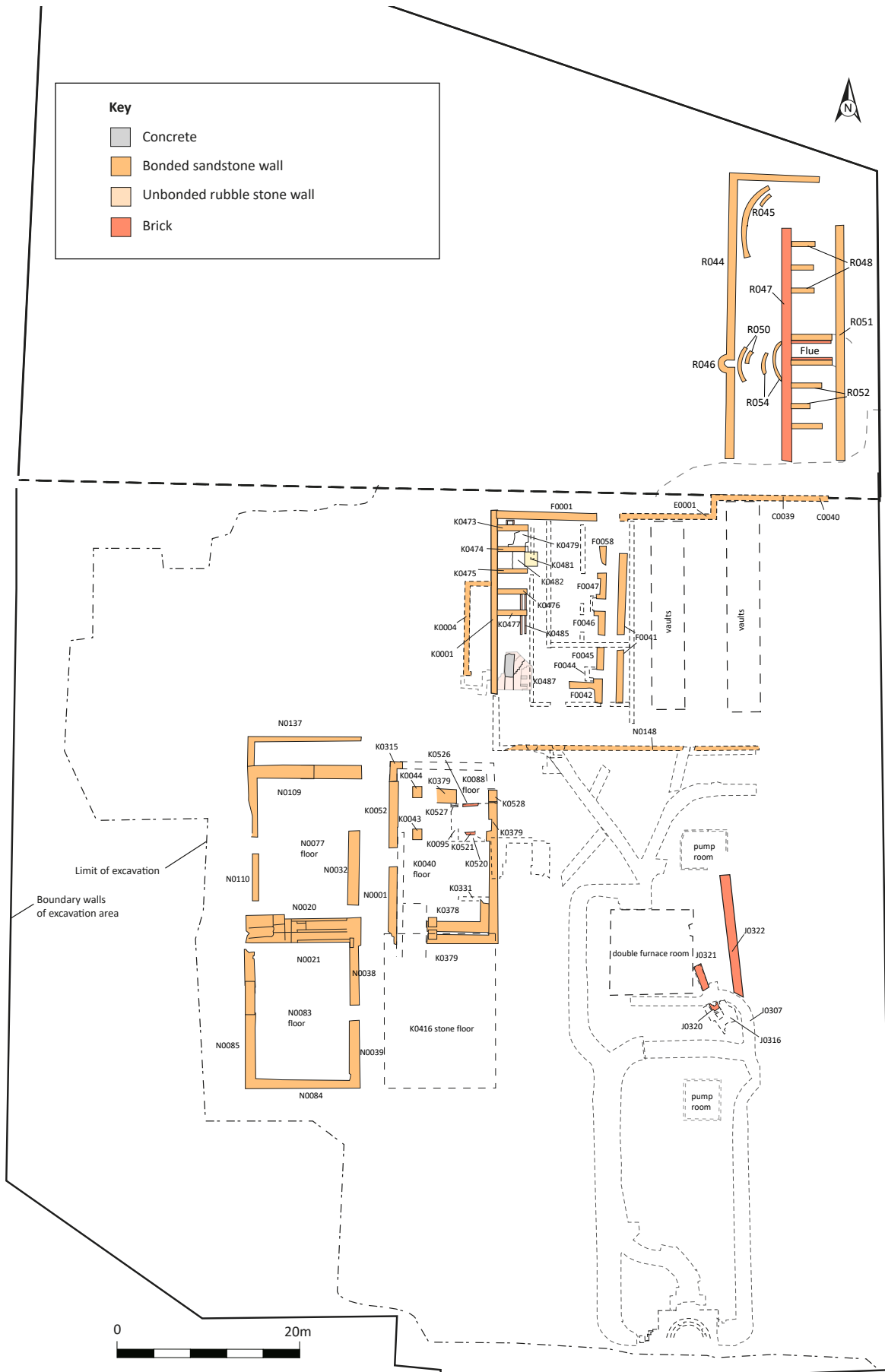

Illus 34 Plan of Phase 2 features



Illus 35 General view of the large stone-walled room to the south-west including floor (N0083)

brick walls while the east wall, (N0032), was badly truncated by Phase 4 construction. The north wall, (N0109), however, was 2.7m high. A large recess with dressed masonry was present in the middle of this wall, 1.04m wide, 0.9m deep and 0.5m high. Another stone wall, (N0137), extending to the north from the west side of (N0109) appeared to form a northern annexe, 3m wide.

To the east of wall (N0032) was another heavily truncated stone wall, (N0001/K0052/K0055), which stood to a height of between 0.5m and 1m. This formed part of another stone-floored structure of approximately the same dimensions as the two-roomed structure to the west. Its north wall, (K0315), was largely obscured by later features. Two stone walls, (K0378) and (K0379), running parallel east/west with a clay infill between them appeared to form the south wall of the northern room of this structure, and the north wall of a second room. A stone floor, (K0416), associated with this southern room, stood approximately 1.3m higher than the stone floor to the north (K0040). At least three stone partition walls ran east/west in the north room of the structure, (K0331, K0520 and K0526) and

both (K0520) and (K0526) incorporated remains of clay-bonded brick flues, (K0521) and (K0527), aligned east/west.

These walls appear to correspond with two large parallel rectangular buildings first depicted on Kirkwood's map of 1821 (Illus 7 & 36), which continued in use within the expanded Gasworks of the mid-19th century (Phase 3), with the eastern building depicted as being used for 'Gas Holders' on the 1852 Ordnance Survey map (Illus 8), while the western building was divided, corresponding with the results of the excavation. The Ordnance Survey describes the northern half as the 'Purifying House' and the southern half as 'Gas Holders'. By Phase 4, only the western building was still depicted on Ordnance Survey mapping (Illus 20). This is substantiated by the greater truncation of the (overbuilt) eastern building.

6.5.2 The major Gasworks building

Elements of another major Gasworks building depicted on Kirkwood's 1821 map were also present in the east of the Gasworks site, to the north-east of the two parallel buildings, though clearly heavily

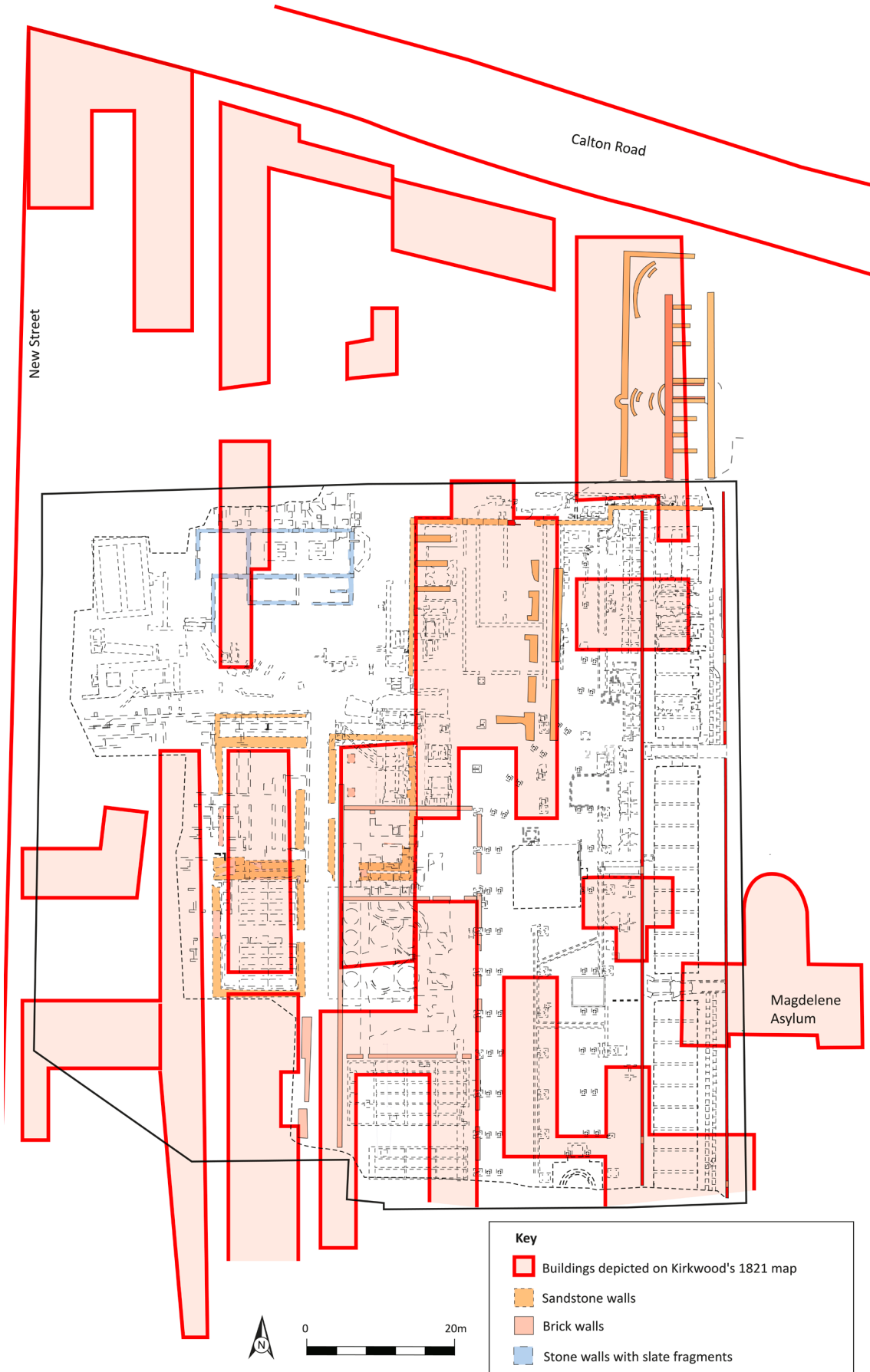

Illus 36 Phase 2 features overlain with features on Kirkwood's 1821 map

altered between Phase 2 and 3. By 1852, it would form part of the major building housing the 'Fire Department, Retorts, &c.' (Illus 8). The outline of this building was apparently defined by wall (F0001/E0001/C0039) to the north, likely largely of Phase 3 construction, west wall (K0001) and potentially south wall (N0148), the latter again likely a later structure. Wall (F0041) may have formed the original east wall of this building while minor wall remnant C0040 appeared to be the earliest element of the north wall.

The upstanding remains of the main west wall (K0001) were probably part of the earliest Gasworks, although truncated during later phases. It stood to a maximum height of 2.85m and was at least 19m long, comprising a sandstone wall bonded with lime mortar. The north end of the wall was keyed into north wall (F0001). The wall possibly joined east/west-aligned stone wall (N0148) at its south end.

Within the building, five stone partition walls, (K0473)–(K0477), ran off the east (interior) side of west wall (K0001); each was approximately 3.4m long and 0.6m wide, and they were set 1.6m

apart, forming four separate compartments open at the east end. Cobbled surfaces (K0479) and (K0482) were present in two compartments, the latter incorporating a cast iron cover (K0481). A stone-lined drain, (K0485), ran north/south along the east edge of the southernmost compartment and continued under and beyond wall (K0477). The function of the compartments is unknown but they were probably associated with the earliest phase of the Gasworks, and could perhaps represent storage compartments or housings for retorts. These walls appeared to be in alignment with further truncated stone walls recorded to the east (F0042), (F0045), (F0047) and (F0058). Potentially wall (F0041), to the east, could have formed an outer wall of the original Gasworks building. It comprised the truncated remains of a rubble wall, 15m long and 0.86m wide.

The east end of north wall (F0001)/(E0001)/(C0039) stood to a maximum height of 1.8m and incorporated reused stone. A section of an earlier stone wall (C0040) was recorded below the eastern end of the main wall, running for 2.8m



Illus 37 Flue (J0322) aligned north/south, from the east

along its base, perhaps the actual remains of the original Phase 2 north wall. This suggests that the earliest Gasworks wall had been demolished and reconstructed in Phase 3.

Only the western wall, (K0001), and sections of the eastern wall (F0041) clearly corresponded with the original major Gasworks building depicted on Kirkwood's map of 1821 (Illus 7), with the north wall of this building having seen major alterations as part of the Phase 3 redevelopment. The remains of the original southern wall of this early building were not securely identified and had clearly been truncated by later activity. Likewise, the majority of the original internal features had been lost to later disturbance.

6.5.3 Early flues

Only three of the many sections of flue identified in Caltongate South could be associated with Phase 2. Early flue (J0320) had been truncated by later features and only a length of 1.5m remained. It was on the same alignment as flue (J0321) to the north and probably formed part of the same system. They were constructed of red firebricks, one course thick, bonded with pink clay. Flue (J0321) was linked to later flues (J0307) and (J0189). Another likely Phase 2 flue, (J0322) (Illus 37), was aligned north/south to the east of J0321. This was constructed of a single course of large yellow firebricks.

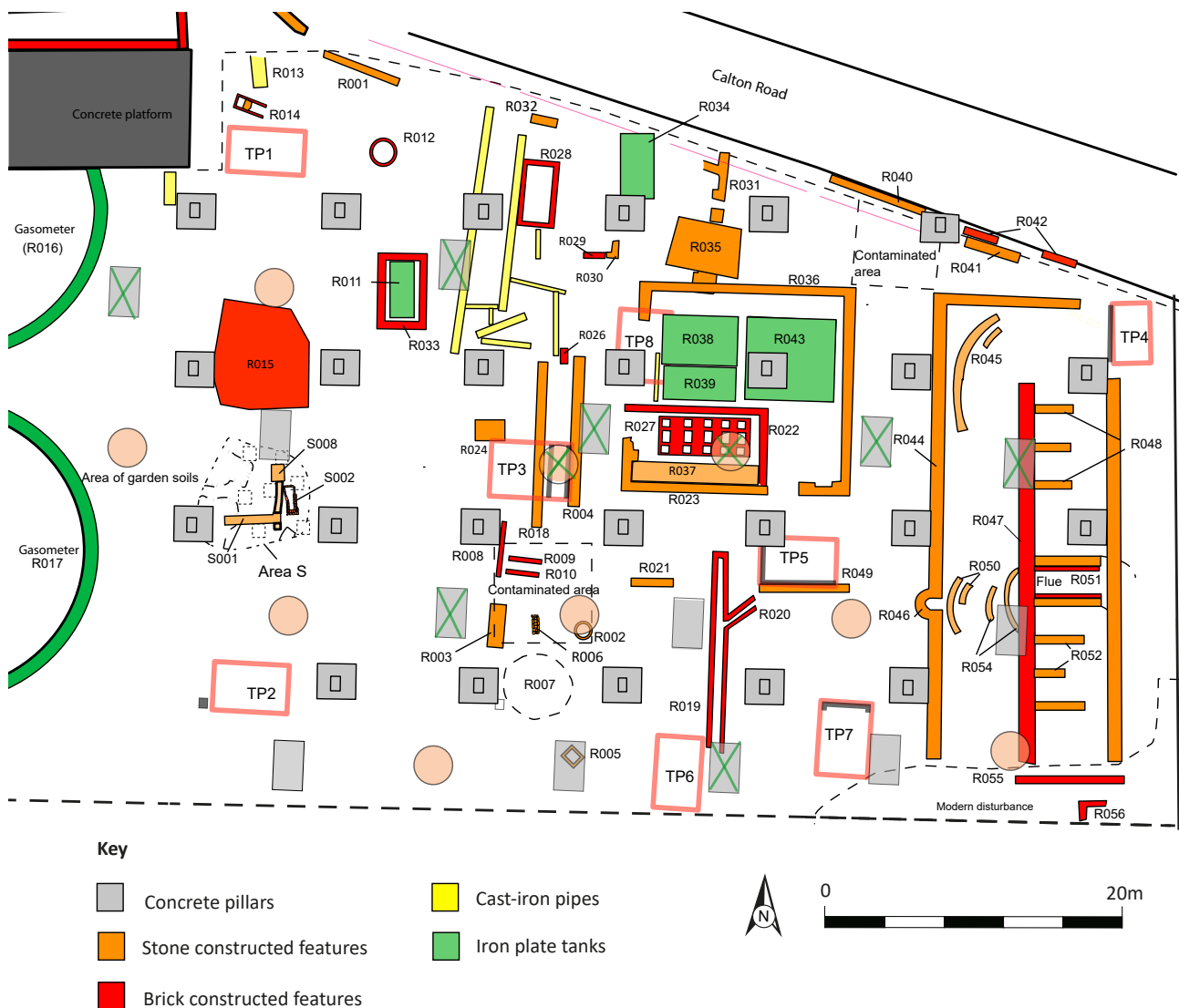

Illus 38 Plan of Caltongate North showing all the features recorded

6.5.4 Gas Holders building

Remains in the east of the northern excavated area form elements of a structure depicted as housing ‘Gas Holders’ on the Ordnance Survey map of 1852 (Illus 8). This likely had its origins as part of the original Gasworks, as Kirkwood’s map of 1821 depicts a building in this area (Illus 7). The stone walls (R044) of this building were of solid stone construction, similar to other early Gasworks buildings recorded to the south, and it is likely that this building saw use in both Phases 2 and 3, though

it had gone by the Ordnance Survey plan of 1877 (Illus 20). Excavated features within the building included curved stone walls, perhaps to hold ‘gas holders’.

Cement-bonded rubble stone wall (R044) (Illus 38) formed three sides of a large rectangular building, aligned north/south. The remains of this wall stood to a maximum height of 3m and defined an area at least 30m north/south by 10.4m west/east. The south wall had been lost to later truncation. Towards the south of the western wall, a rounded stone buttress, (R046), projected 1.5m to the west



Illus 39 Detail of stone buttress (R046), taken from the south

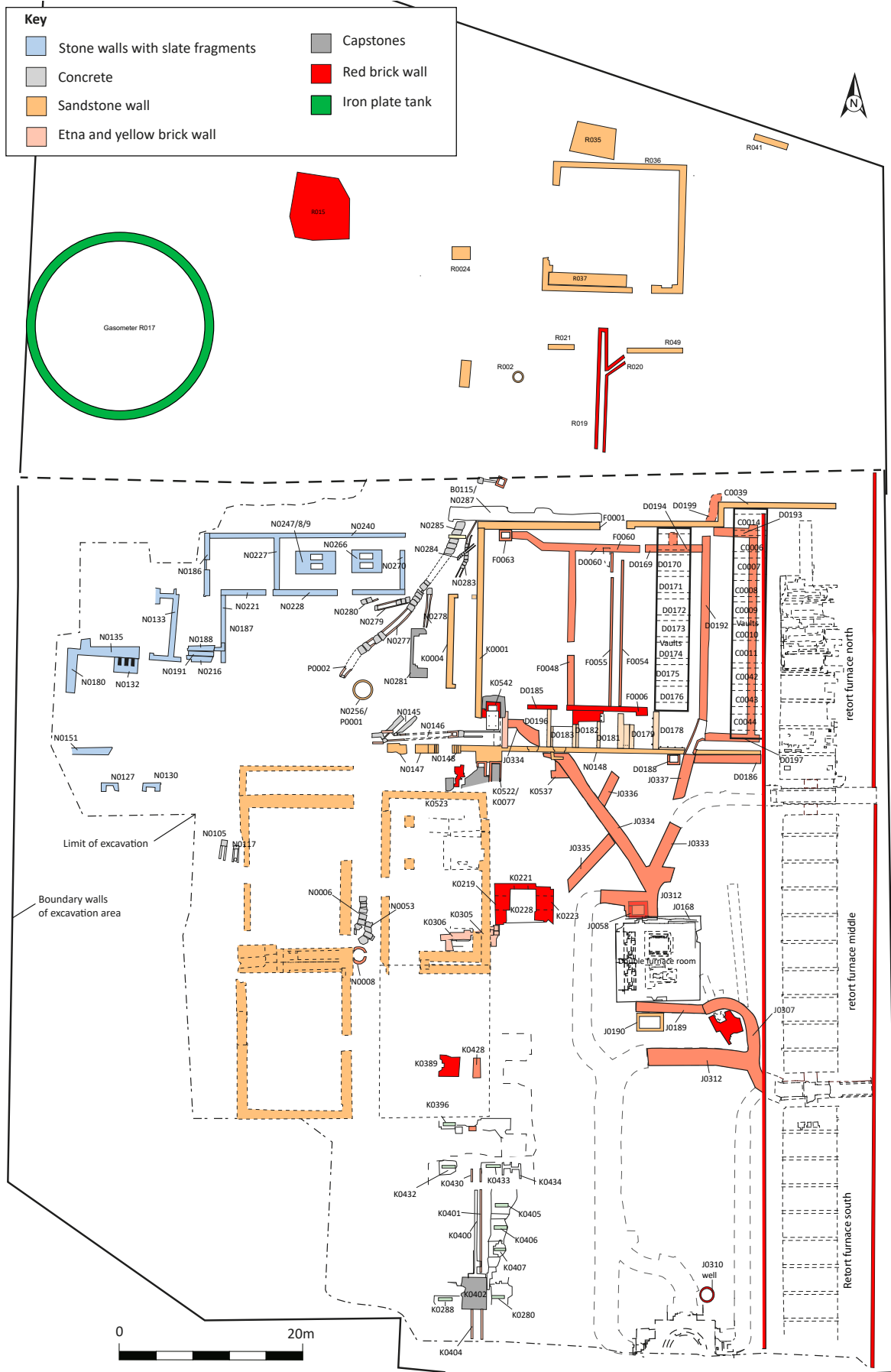

Illus 40 Plan of Phase 3 features

(Illus 39), a feature clearly identifiable on the 1852 Ordnance Survey map (Illus 8) as the central of three buttresses of the 'Gas Holders' Building.

East of wall (R044) a series of curved stone wall sections, (R045), (R050) and (R054), were recorded. Curvilinear stone wall (R045) in the north-west corner of the 'Gas Holders' building stood to a height of 1.5m. A smaller section of curved wall was recorded just behind it. To the south, two further sections of curved stone wall, (R050), were recorded immediately east of buttress (R046). The outer wall of (R050) was 0.62m wide and the inner 0.70m wide with a 0.65m gap between. A third area of parallel curved walls, (R054), was recorded to the east of (R050). The inner of these curved walls stood 1m to the east of the outer, and it abutted a brick flue base, (R047). These walls were interpreted as remains of the structures that supported the earliest gasholders on the site.

The red brick flue base, (R047), which ran 24m north/south through the 'Gas Holders' building, was heavily truncated. It was 1.2m wide, stood to a maximum height of 1m, and was bonded with sandy clay. A smaller red brick flue, (R051), ran to the east from this main flue. The brick side walls of this flue were supported by stone outer walls, 0.7m wide. The internal width of the flue was 0.57m and it ran east for 3.5m before turning to the south, perhaps continuing through the building wall to the east. Two sets of east/west-aligned lime mortar-bonded stone walls, (R048) and (R052), also ran east from the main flue. Three wall segments to the north, (R048), stood 1.7m apart, while three walls located to the south, (R052), were only 1.4m apart. It is uncertain whether the flues and associated features were part of the original Gasworks, or if they were introduced as part of the expansion *c* 1845.

6.6 Phase 3 (*c* 1845–*c* 1875) (Illus 40)

6.6.1 The major Gasworks building (Fire Department and Retorts)

Large parts of the workings of the redeveloped Gasworks from the mid-1840s onwards, including the retorts, chimneys and complexes of flues, were housed in an expanded building in the east of the excavated area, described on the Ordnance Survey map of 1852 (Illus 8) as 'Fire Department, Retorts, &c.'.

The truncated remains of a stone structure, (B0115/N0287), which appeared to continue below stone wall (F0001), formed the possible foundation for the Phase 3 north wall of the rebuilt major building of the expanded Gasworks. In Phase 3 this building was bounded by wall (F0001/E0001/C0039) to the north, and (K0001) to the west. Stone foundation (B0115/N0287) was at least 15m long and projected to the north from the wall by approximately 1.5m. These formed northern elements of the major building marked on the 1852 Ordnance Survey map (Illus 8) as 'Fire Department, Retorts &c.'.

To the south was another stone wall, (N0147)/ (N0148), aligned east/west, which stretched for a significant length (Illus 41). At the west end, wall (N0147), 5.5m in length, was constructed of large stone blocks and was roughly faced on its north elevation. After a 1m wide gap, the wall continued as (N0148). A section of this wall partially enclosed two brick flue vents, (K0522) and (K0077), before the wall continued to the east. Close to the east end of the wall, a brick vent, (D0188), abutted the south face while a brick flue, (J0337), ran through the wall. At this point the wall incorporated squared stones of an earlier opening and potentially, sections of this wall may belong to Phase 2.

6.6.2 Vaults

Within this major building of the Gasworks, excavation revealed three banks of vaults, potentially for housing retorts, which belonged to the expanded Phase 3 Gasworks complex. These vaults extended 21m to the south where they were bounded by an east/west-aligned stone wall (N0148). Two north/south-aligned groups of vaults (Illus 42) were not keyed into the main walls of the building that enclosed them whereas the east/west-aligned vaults to the south were keyed into the south wall. These southern vaults were also constructed differently, suggesting that may have been part of a different sub-phase of construction. However, the southern end of the western bank of north/south-aligned vaults were keyed into the southern bank of vaults, suggesting they were constructed together. In any case, all were part of the expanded Phase 3 Gasworks, with the eastern bank being reused in Phase 4.



Illus 41 General view of the east end of stone wall (N0148) from the south

The bank of ten vaults to the east, (C0006)–(C0011), (C0014), (C0042), (C0043) and (C0044), with the exception of those towards the south (C0043) and (C0044) (both likely modified in Phase 4), were all 1.97m high, 1.74m wide and 2.7m deep. The brick arches were supported on stone-built pillars and the lower sections of the stone walls of the vaults were covered in a brittle burnt residue that was also recorded on the front face of the northern vaults.

The second bank of nine vaults, (D0169)–(D0176) and (D0178), stood 4.7m to the west of the first bank; all measured 1.69m high, 1.74m wide and 3.7m deep. The construction was the same as those to the east, with stone pillars supporting a brick arch. A narrow rubble-filled gap lay between the vaults and east/west-aligned stone wall (C0039)/ (E0001). The vaults were open on both the east and west elevations, as the bank of vaults to the

east would have originally been. In addition to two large beam slots above the east face of each arch, between (D0173) and (D0174) was a large square stone-lined recess (D0177).

A section of wall beyond (D0176) formed the interior, west-facing elevation of the first of a series of five further vaults: (D0179), (D0181)–(D0183) and (D0196), located along the north side of stone wall (N0148). As the west-facing wall beyond Vault (D0176) continued to the south to form the internal wall of vault (B0179), the vaults were probably part of the same construction phase. While vault (D0179) was constructed of large unfrogged bricks on a stone base, vaults (D0181)–(D0183) and (D0196) included stone vaulting instead of brick. The south walls of these vaults also formed the north elevation of the main east/west-aligned stone wall (N0148).

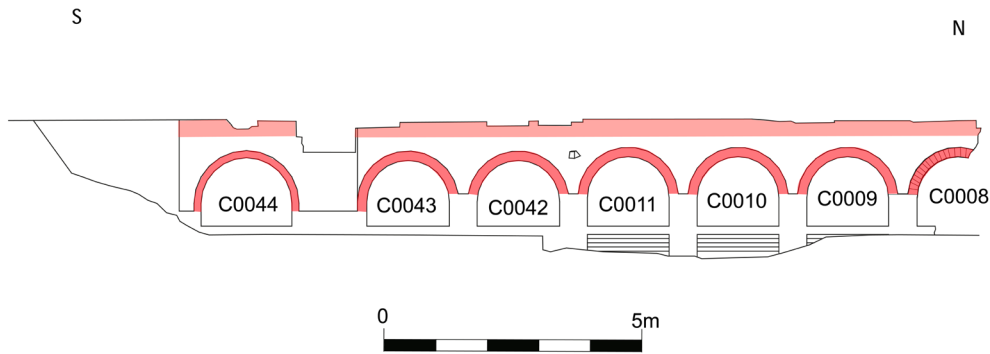

Illus 42 East-facing elevation of stone and brick vaults

6.6.3 Flues connected with the vaults and major Gasworks building

A complex of flues crossed the site, running in all directions, many being blocked or otherwise altered, making the phasing of these features difficult, although some of the larger flues were obviously associated with Phase 4, such as (J0306), (J0312) and (J0313), which emerged from the southern chimney (J0240) (Illus 43).

Flues that were thought to be associated with Phase 3 included (J0337) and (J0334), and were constructed of firebrick. Between the two main banks of vaults mentioned above, the floor had been badly truncated, although small areas of stone cobbles were recorded. Below the cobbles and vaults was a series of brick flues, mainly aligned north/south. Flue (J0337) ran through stone wall (N0148) before continuing north as (D0192). The flue was constructed of a single course of heat-affected bricks bonded with pink clay, standing 1.15m high and 0.07m wide. Approximately 1m from the south end of flue (D0192) a connecting flue turned off to the east, (D0197). A further 20m to the north a second connection, (D0194), turned to the west (Illus 44), while a third flue, (D0193), turned to the east near stone wall (C0039). Flue (D0194), labelled (F0060) to the west, continued west for 17m, running below the western bank of vaults, ending at a vertical vent, (F0063), bounded by stone walls (K0001) and (F0001). Further vents were recorded on various of the flues. Another flue, (F0048), turned to the south, running below Vault (D0183) and possibly joining flue (J0334) to the south of stone wall

(N0148). The truncated brick footprints, (F0054) and (F0055), of a further north/south-aligned flue were identified to the east of (F0048).

It is possible that the original layout of the flues saw (J0337) continue south to a junction with (J0334) prior to connecting with (J0332), which formed a large flue opening (J0169) in the north wall of the chimney basement area (J0168) prior to it being blocked. A spur, (J0335), led off to the west from (J0334); this possibly led into minor chimney (K0228). A second spur to the east, (J0336), probably linked up with flue (F0054)/(F0055) to the north. To the north-east, flue (J0334) appeared to connect with a brick-lined damper system (K0542) (to regulate airflow), with its original chain and pulleys still in situ (Illus 45), which linked up with a second flue, (N0200), to the west beyond wall (K0001) and a truncated flue to the north, (K0487).

The remains of a large brick-vaulted flue, (K0547), approximately 3m high and 0.69m wide, were recorded (Illus 46). The flue, constructed of heat-affected bricks, included a brick base with vertical vents on its east side. The lining of the flue had a hard, glass-like, residue, indicating the substantial heat present when the flue was in use. Given the position of this flue within the boundary of the original stone walls (K0001) of the Gasworks, potentially this was an early (Phase 2) feature.

6.6.4 The major chimney

The expansion of the Gasworks in the 1840s saw a significant reconfiguration of the industrial complex with the addition of a large chimney. Remains of a

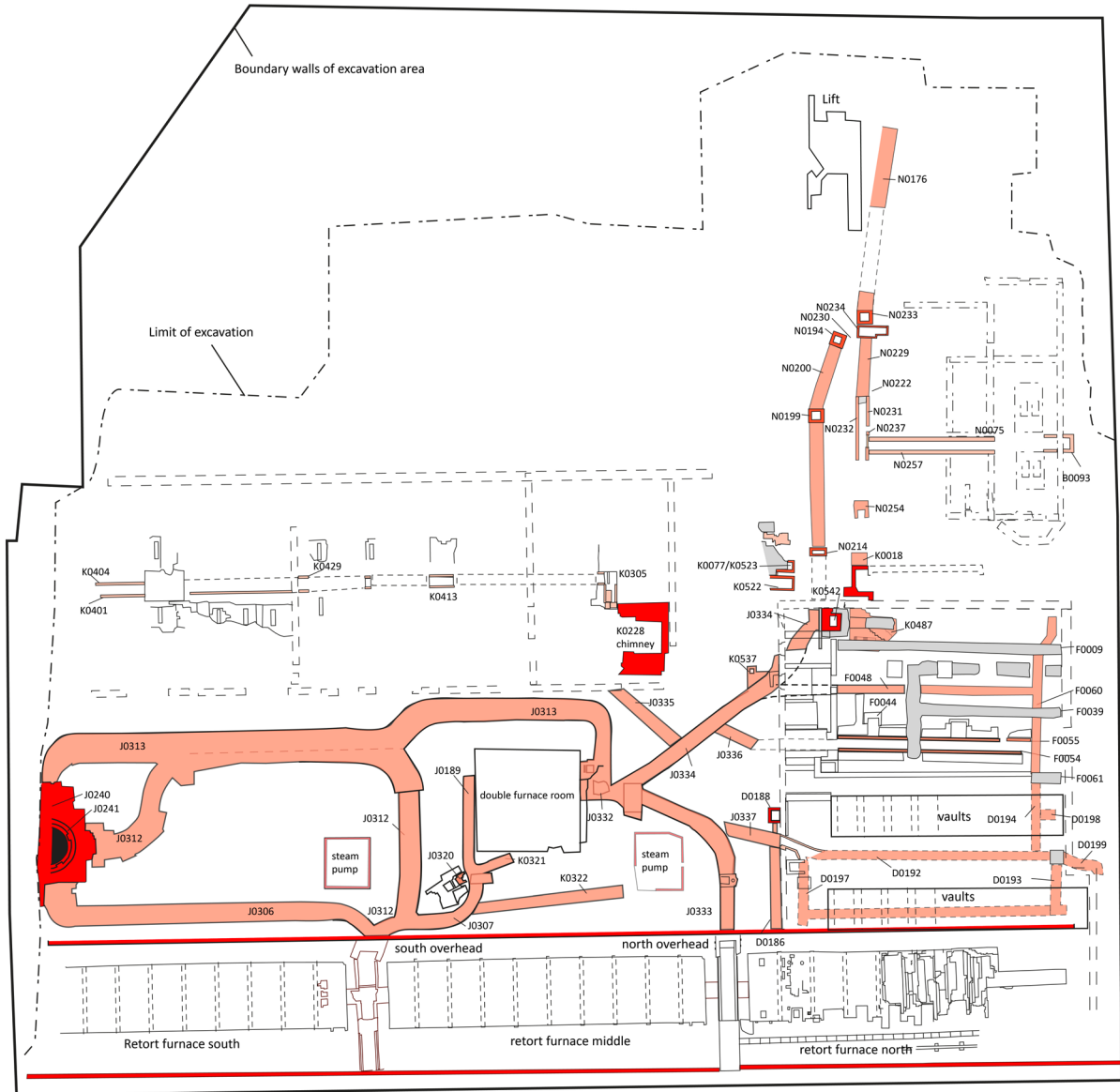

- Key**
- Brick flues
 - Red brick walls
 - Concrete



Illus 43 Plan of all recorded brick flues



Illus 44 Flues (D0192) and (D0194) taken from the north



Illus 45 Detail of damper system (K0542) from the north



Illus 46 Section through flue (K0547) showing the heat-affected bricks

substantial stone wall (J0168) (and other smaller sections), likely part of the base of the chimney, were recorded in the location of the chimney depicted on historic maps. This was in the north-east corner of a large basement area (Illus 47), which contained two large brick furnaces of complex multiphase origin. It was interpreted that two main phases of activity could be assigned to the basement level room associated with the chimney. The furnaces in this area appeared to form part of the final phase of Gasworks activity (Phase 4). The initial activity (Phase 3) was associated with stone walls of the Phase 3 chimney along with a large (brick-blocked) flue to the north and a smaller blocked flue to the south.

Parts of the early chimney included sections of stone wall recorded at the base of the east wall, (J0160) (Illus 48), and sections of the north and south walls. Stone-built structures on the east wall, (J0165), (J0175) and (J0176), were located intermittently along the base of the later brick wall.

To the north, a much larger 4.5m section of stone wall, (J0168), up to 2.6m in height was revealed to have an outer face that stepped out significantly. Behind later brick walls (J0290) and (J0291) on the south wall of the basement area were the truncated remains of a stone wall, (J0292), probably also part of the original basement area.

The presence of substantial stone walls, particularly on the north side of the basement area, along with early flues indicates that this feature was likely a chimney base. Overlaying the 1852 Ordnance Survey map over a plan of excavated features of Phase 3 (Illus 49) supports this as the location of the chimney of the Phase 3 Gasworks.

6.6.5 Flues associated with the main chimney

Two large flues, of which (J0169) was the larger, incorporated remains of a stone arch (J0183). This was probably associated with an early phase of the structure along with stone wall (J0168) to the east,

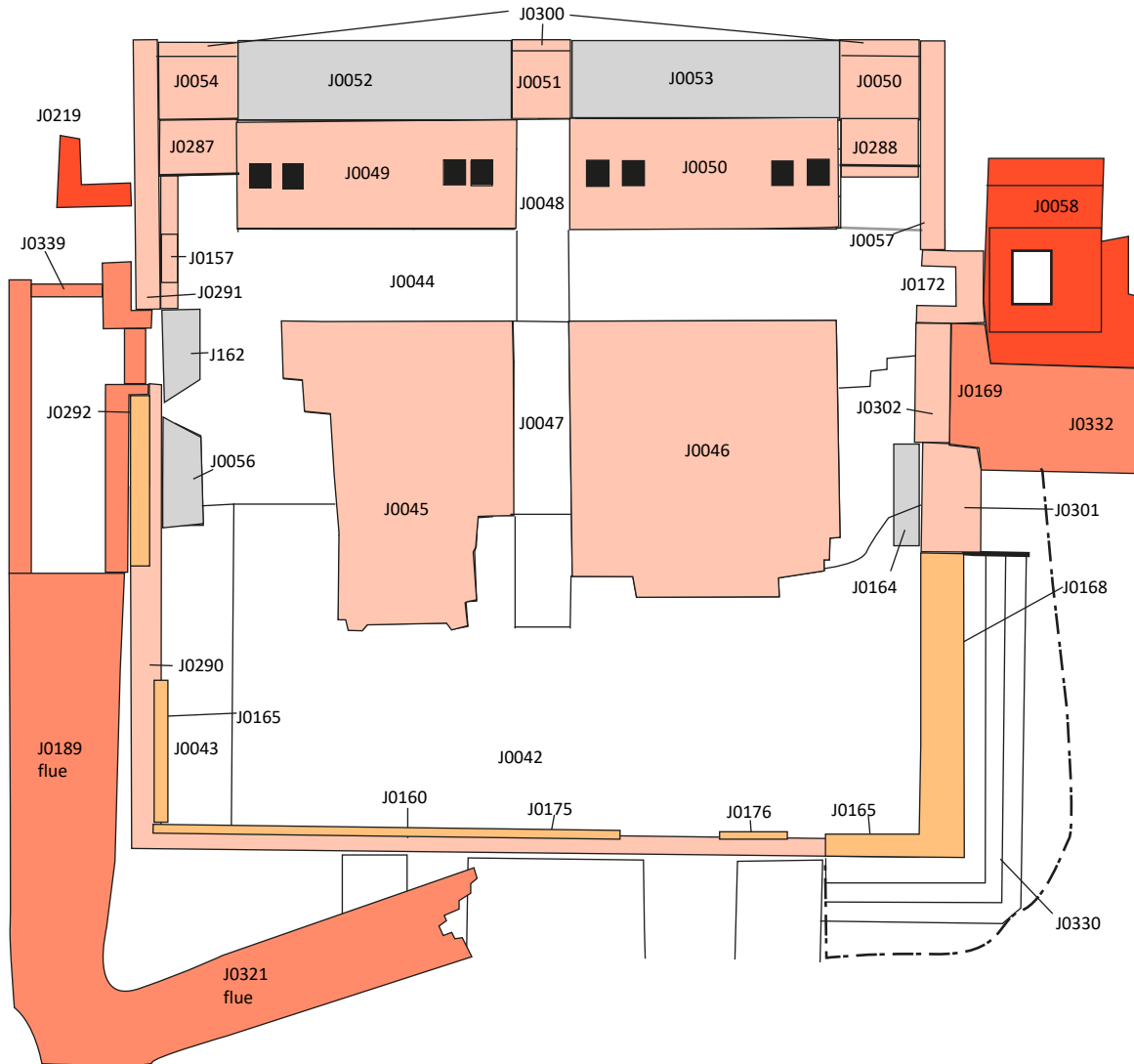

Illus 47 Plan of double furnace room



Illus 48 Stone wall (J0160) at the base of the east wall of furnace room

although it had been separated from the wall by a section of brick wall (J0301). The flue had originally continued to the north as flue (J0332), which in turn split into flues (J0333) and (J0334). These substantial features were likely in use prior to the insertion of the two (Phase 4) furnaces.

6.6.6 Flues in the west of the Gasworks

As noted above, an east/west-aligned flue, (N0200), extended across the west side of the Gasworks complex, with brick vents (N0194) and (N0199) to the west and east. The flue continued a further 11m where a third brick vent, (N0214), was recorded and likely continued east towards damper (K0542), linking up with flue (J0334).

6.6.7 Retort benches

The north and middle groups of retort benches located along the eastern side of the site were likely

originally constructed during Phase 3, although the surviving structures were likely of later (Phase 4) construction (as were those to the south), perhaps remains of the 40 retorts inserted in 1888 (Cotterill 1976: 1064–5). They stood within the limits of the major Phase 3 building (Illus 49). Flues (J0307) and (J0189) linked the south end of the retort benches (possibly one long bench at this time) to the chimney area. To the south of flue (J0189) was a stone-lined vaulted chamber, (J0190), entered via a cast iron cover.

6.6.8 Minor chimney and associated flues

A possible second chimney structure of Phase 3 date was recorded, (K0228), heavily truncated by Phase 4 features (Illus 50). Brick flues appeared to lead into the area, although no clear links could be made due to heavy truncation and the walls of the putative chimney structure did not appear sufficiently substantial to support a tall structure.



Illus 49 Phase 3 features overlain with features on 1852 Ordnance Survey plan



Illus 50 General view of the chimney area (K0228)

The remains of a series of heat-affected brick surfaces were linked to remains of a brick flue system. In the south of the site, brick flue (K0401), (K0404) and (K0430), constructed of bricks bonded with lime mortar, ran for 16m northwards. On each side of the flue were truncated heat-affected red brick surfaces (K0353)–(K0358), (K0405)–(K0407), (K0432) and (K0433). These were each approximately 2.5m by 1.6m with a central cast iron trough, 1.26m by 0.28m, aligned east/west. These features may represent a series of pumps with each iron trough the location of a wheel pit.

To the east of brick floor (K0433) was a series of low brick walls, (K0434), forming small cells set into a layer of clay. Fragments of further heat-affected brick surface and flue features were identified further to the north. The northernmost of these features, flue (K0305), included the remains of a damper system. Flue (K0305) continued into the area of chimney (K0228), which comprised a brick floor surface measuring 3.97m by 3.67m with the

remains of three large vaulted flues to the east, west and north. On the south side, flue (K0230) was only visible in section. The west flue, (K0219), was constructed of red ‘Glenboig’ brick; to the north and east, flues (K0221) and (K0223) were of identical construction. The internal walls of the flues had no residues and the purpose of the area was unclear as the walls did not appear substantial enough to hold a tall chimney.

6.6.9 The annexe to the major building

Phase 3 saw the addition of an annexe on the west side of wall (K0001) of the major Gasworks building. A short section of rubble wall, (K0003), abutted this main wall and joined north/south wall (K0004), which formed an annexe, 7m in length. At the south end, the wall turned back to the east, (K0019). Within the annexe, but possibly added during Phase 4, was a small retort furnace (Illus 51) (K0006)–K0010) with a small coke oven at the base with two cylindrical clay horizontal retorts, which



Illus 51 Detail of small retort furnace (K0006)-(K0010) from the north

could have been used to test the different coals prior to use in the main furnaces. This annexe is clearly depicted on the Ordnance Survey map of 1852 (Illus 8).

6.6.10 The meter house

Further substantial stone walls, (N0216), (N0187), (N0221), (N0227), (N0240) and (N0186), to the west of the annexe likely represented the meter house (and ancillary structures) depicted on both the 1852 and 1877 Ordnance Survey maps (Illus 8 & 20). A large room recorded in the east of this building contained two large stone-built machine foundation bases (N0247)/(N0248)/(N0249) and (N0266) (Illus 52), both measuring 2.95m by 2.84m by 1.8m and containing two parallel wheel pits aligned east/west. Later elements of the Meter House included a 2.3m high rubble wall (K0494), aligned north/south, recorded as (N0228) and (N0270) at a lower level. A section of stone rubble wall (K0515) was added to the east face, forming a small room, while

brick-built wall (K0492) had been added (possibly in Phase 4) to the south end, forming another room.

Several further stone walls were likely associated with the Phase 3 expansion. To the west of the Meter House, walls (N0135) and (N0180) comprised mortar-bonded rubble walls, approximately 1.1m wide and over 3m high (Illus 53). Against the south side of wall (N0135), remains of a large brick engine mounting block (N0132), which included a small wheel pit, were recorded. The phasing of this feature is uncertain, and it could have housed later (Phase 4) pump machinery. To the north, truncated wall (N0133) was of similar construction to (N0135). Similar truncated walls were recorded to the south, (N0127) and (N0130).

6.6.11 Drainage

A complex of brick-lined drains with stone caps were recorded in Area N towards the centre of the Gasworks, near the annexe to the major building. To the north, drain (N0280) was truncated by



Illus 52 Machine mounting bases (N0248)

stone wall (N0228) of the Meter House, indicating that the drains were earlier than this structure. Two further drains on a broadly similar alignment, (N0277) and (N0279), joined at their east ends where they connected with a brick-lined vent. Drain (N0278), aligned north/south, extended from the vent to a stone-lined sump (N0281). The three drains united as drain (N0285) to continue to the north-east. Sump (N0281) was 3.7m long and at least 2m wide and its walls were covered in a white residue.

Four wells were located during the excavations that, though difficult to date, may be associated with this phase. Well (J0310) (Illus 54) was located close to the later chimney base (J0240). It was constructed of yellow firebricks bonded with grey cement and was 1.1m in diameter and at least 2.1m deep. To the north-west, between the parallel rectangular buildings of the Gasworks, a second brick well, (N0008), was recorded. This well, which appeared to post-date Phase 2, was 1.22m in diameter and

was recorded to a depth of 2.15m. A stone-lined well, (R002), to the north could potentially be of pre-Gasworks origin, although it was interpreted as more likely to belong to Phase 2 or 3. This was cut into an area of dark (backland) soil and had a depth of at least 2m. A fourth well, (N0256)/(P001), constructed of stone blocks, was possibly of an earlier date and is discussed in Phase 1 above.

6.6.12 Coal shed

The expansion of the Gasworks in the middle of the 19th century saw the introduction of large coal sheds in the north-west of the development, towards Calton Road. However, little evidence was found for the Phase 3 coal sheds during the archaeological works. Two short sections of stone wall, (R003) and (R024), may have formed elements of the eastern wall of the large Phase 3 coal shed, visible on the 1852 map (Illus 8). In addition, a section of brick floor, covering an area 5m by 3m, (R015), could have belonged to this building.



Illus 53 Wall (N0135) from the south-east



Illus 54 Brick well (J0310) from the north

6.6.13 Western gasholder

The possible remains of large circular gasholder, also visible on the 1852 map, were recorded to the west. The 16m diameter base of a cast iron tank, (R017), was constructed with large plates of iron, riveted together, with a series of brick buttresses around its circumference.

6.6.14 The smaller 'Gas Holders' building

A series of stone wall bases further to the east appeared to be located on the footprints of buildings depicted on the 1852 Ordnance Survey map (Illus 8). Together, rubble walls (R036) and (R023) formed a large square building. Its south-west corner was formed by (R023), which extended 9m east/west before turning to the north for 3.5m. An area of stone floor, (R037), lay north and east of this wall. Rubble wall (R036) was a more extensive feature, forming both the 13.5m long north wall of the building and its east wall. The location of these walls corresponded with the smaller 'Gas Holders' building depicted on the 1852 map.

6.6.15 Smithy

The 1852 Ordnance Survey map labels an annexe to the south of the smaller 'Gas Holders' building as a 'Smithy'. Small sections of stone wall base, (R021) and (R049), may be remains of the southern wall of this annexe. Both were constructed of lime mortar-bonded rubble. Wall (R021) was 2.5m in length while wall (R049), to the east, was over 4m in length. Separating these segments of wall was a 12m long brick-lined drain, aligned north/south, (R019). A second drain, (R020), aligned south-west/north-east, extended from its west side. This drain was either associated with the smithy or was a later feature.

6.6.16 Northern building

To the north of wall (R036), large square stone blocks formed a floor surface, measuring 5.1m by 3.1m, (R035). This floor appeared to be part of a building of unknown purpose depicted on the 1852 map, fronting on an area of rail tracks at the north of the Gasworks.

6.7 Phase 4 (c 1875–1906) (Illus 55)

The design of the Phase 4 Gasworks aimed to speed up the processes involved, from the introduction of the coal onto the site to the distribution of gas through the city. For example, the coal sheds were moved to the east, closer to the retort benches. From there the gas produced was sent through a series of purification processes, removing waste by-products. The gas was then passed through the meter house before entering the gasholders.

As the cartographic evidence demonstrates (Illus 8 & 20), a major expansion of the Gasworks facilities took place between 1852 and 1877; these also show the development of railway access for the provision of raw materials and the exporting of by-products. At the time of the Ordnance Survey map of 1877 (Illus 20) the Gasworks was in transition, with the expansion of coal sheds to the east and the reconfiguration of much of the rest of the Gasworks. By the time the Gasworks closed in the early 1900s, a multiplicity of processes took place on what had become a crowded site without space for expansion. The detailed plan of 1915, when overlaid over excavated remains (Illus 56) represents the full extent of the developed Gasworks. Many of the depicted features correspond with the excavated remains. Commonly, Phase 4 features were of a similar yellow brick construction.

6.7.1 The central chimney (Illus 47)

During Phase 4, the south wall of the major chimney depicted in the centre of the 'Fire Department, Retorts, &c.' building on the Ordnance Survey map of 1877 (Illus 20) incorporated brick walls (J0290), (J0291) and (J0158) with a small flue (J0157), which mirrored one on the north wall (J0172). Flue (J0157), together with the large vents to the rear of the furnaces, would have facilitated airflow. The various Phase 4 flues connected to the chimney and its double furnaces were used to channel air through the retort benches to regulate heat.

6.7.2 The double furnaces

The large basement area associated with the main chimney (Illus 47 & 57), approximately 9m by 10m in plan and 2.6m deep, contained two large brick-built furnaces, (J0045) and (J0046), both aligned

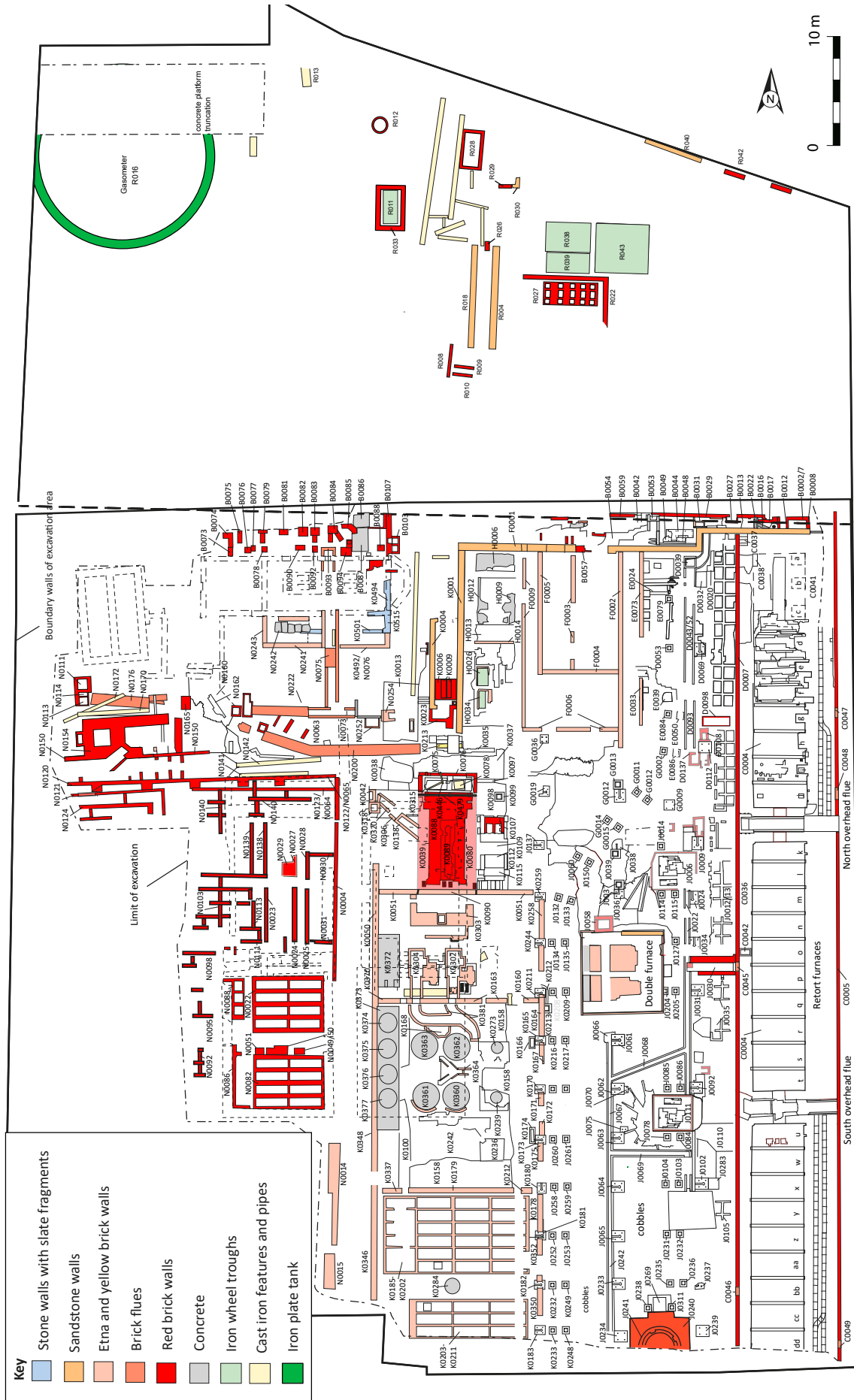

Illus 55 Plan of Phase 4 features

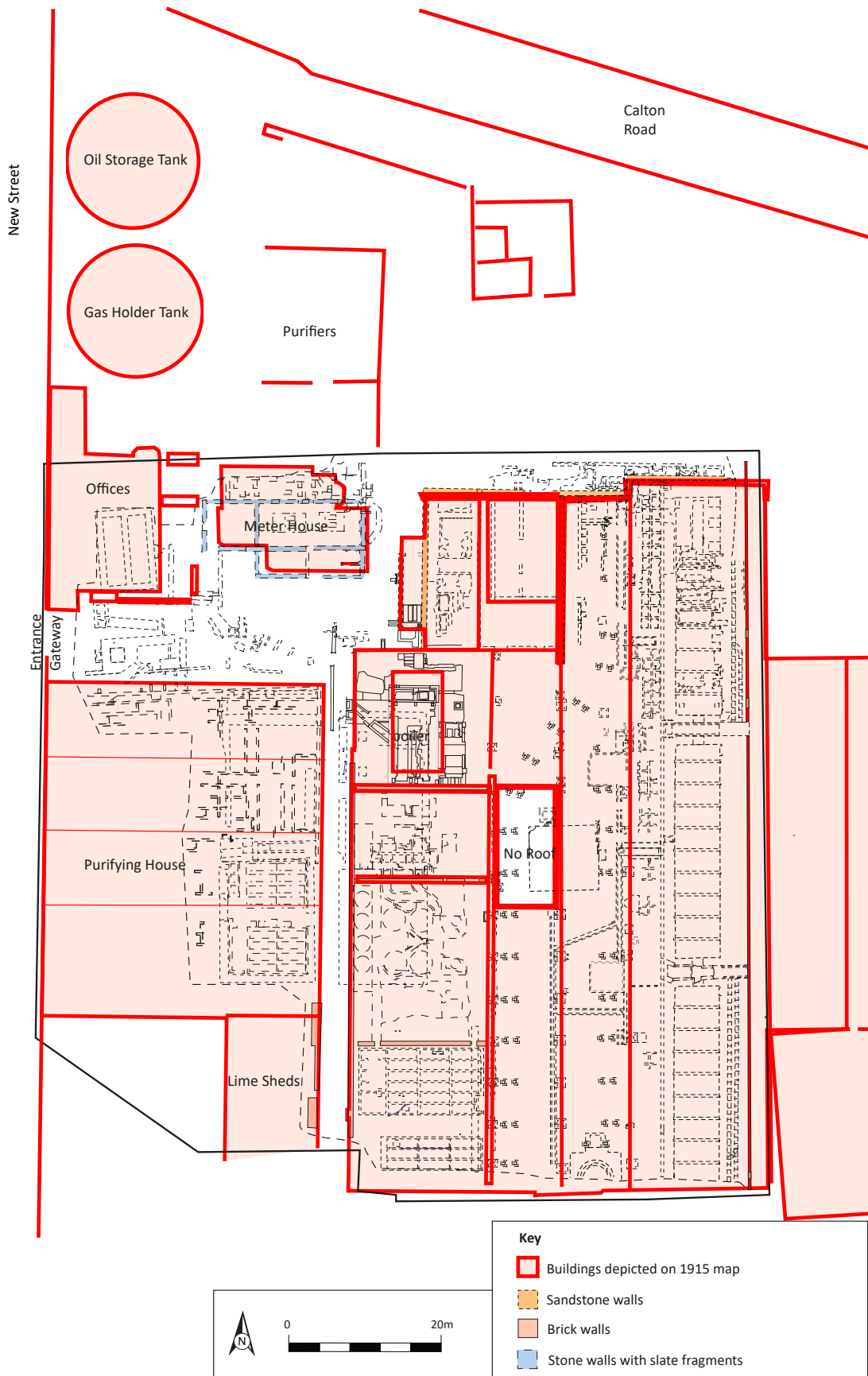

Illus 56 Phase 4 features overlain with features of detailed 1915 plan

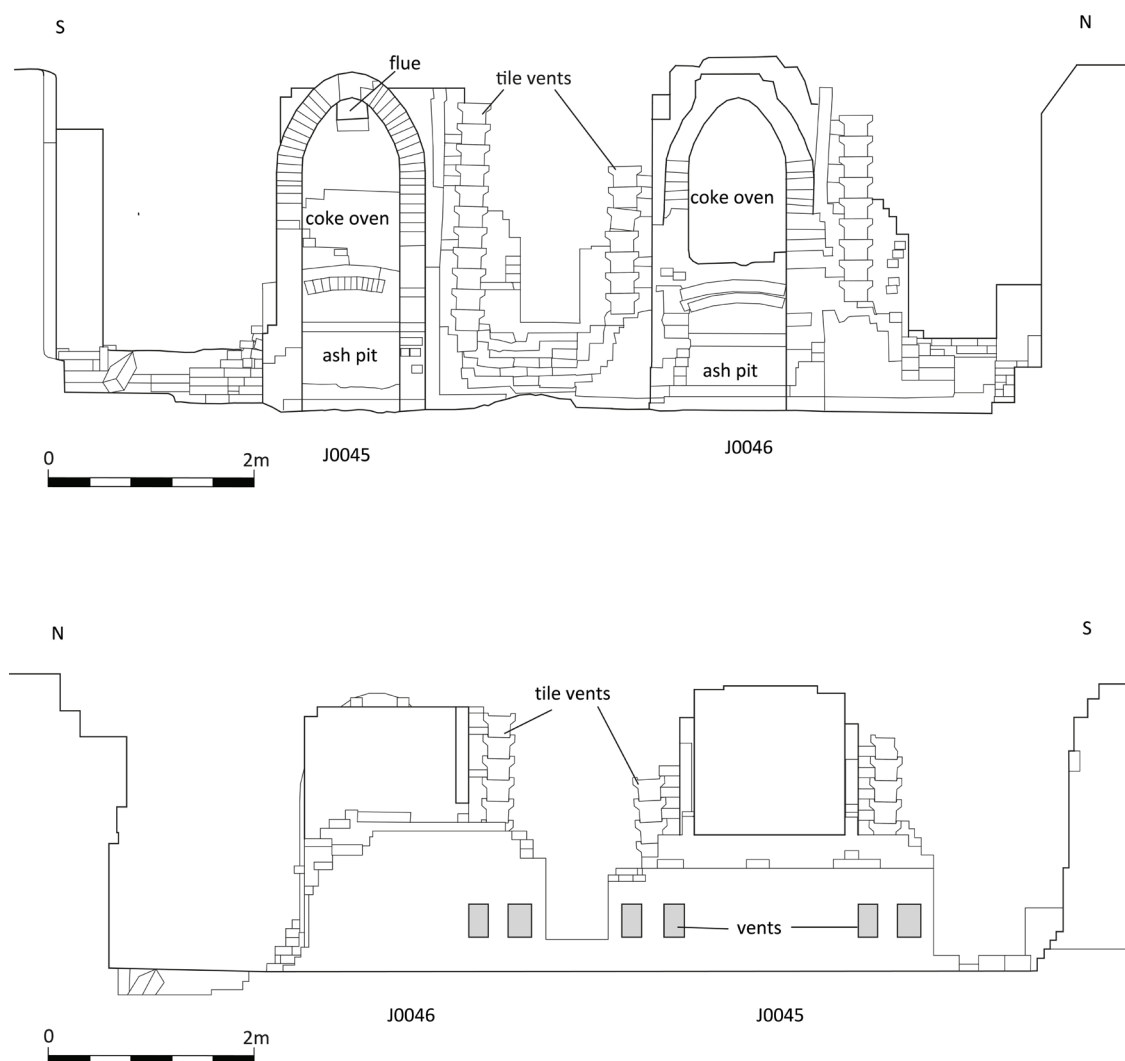

Illus 57 Elevations of double furnace room

east/west (Illus 57 & 58), interpreted as Phase 4 features. The furnaces varied in shape and scale. The furnace to the south (J0045), 3.5m by 2.3m in plan and 3m high, was slightly longer and narrower than (J0046), with dimensions of 2.9m by 2.75m by 3.26m. Both were constructed of unfroged red firebrick. On each side of both furnaces were structures of fired clay square tiles forming vertical flues. The front (east-facing) elevation of furnace (J0045) comprised two openings, the lower half being the ash pit, the upper being the furnace oven. The lower portion included a sloping brick base above which were two iron beams, which would have held a grate above the floor to separate the spent coke and ash. On each side of the east elevation of the furnace, close to the base, was a

small section of brick wall that included two small vents with iron covers that could be raised or lowered to alter the airflow through the furnace, regulating the heat of the furnaces. The main chamber above the ash pit was 1.9m high, 1.5m deep and 0.94m wide with an arched head and a corbelled rear wall that included a small flue opening at the base and a second flue at the top. This formed the main coke oven that would have heated structures above. Gas may have been reheated to extract impurities. The second furnace, (J0046), to the north, which was in a better condition, was of similar design.

Two firebrick platforms, (J0049) and (J0050), were separated from the furnaces by a narrow gap. Each platform measured 3.04m north/south by 1.29m east/west with a height of 1.20m and had two

sets of double vents that ran from the east elevation, where they mirrored vents on the furnaces (Illus 59). Immediately to the rear (west) of these platforms were two large concrete covers, (J0052) and (J0053), which abutted a yellow brick wall (J0300) that formed the western limit of the basement.

6.7.3 Flues associated with the Phase 4 chimney and double furnaces (Illus 43)

To the north of the furnaces, brick-lined flue (J0172) had a door/shutter constructed of four large blocks of concrete encased in an iron frame. This formed part of a damper system that was operated from above the flue. The flue continued to the north where it connected with the main flue (J0313). To the south, behind the basement area, was a flue opening, 0.85m high and 0.74m wide, which led into an east/west-aligned flue, (J0189), which led towards the retort benches. Possibly of Phase 3 origin, the opening had been blocked with ‘ETNA’ firebricks.

6.7.4 Retort benches

Three banks of retort bench furnaces, (C0006), were recorded in the east of the excavation area (Illus 60, 61 & 62). It is likely that these 30 retorts were part of the 40 retorts constructed in 1888 (Cotterill 1976: 1064–5). Phase 4 saw the apparent expansion of the furnaces to the south, with new flues placed between each set of ten furnaces to regulate airflow. These flues connected with chimney (J0240) at the south of the Gasworks and to the major 1840s chimney.

A series of 30 furnaces (a–dd) were set in groups of ten, bounded to the east by a 2.42m high brick wall, (C0005), likely also the west wall of the Phase 4 coal sheds. On the west side of the furnaces was another significant brick wall, (D0007). In general, the retort benches at the north end (a–j) were in worse condition than those to the south, with the lower sections of the second and third groups of benches mostly intact.

Each retort bench was constructed of firebricks bonded with sandy clay. The major surviving

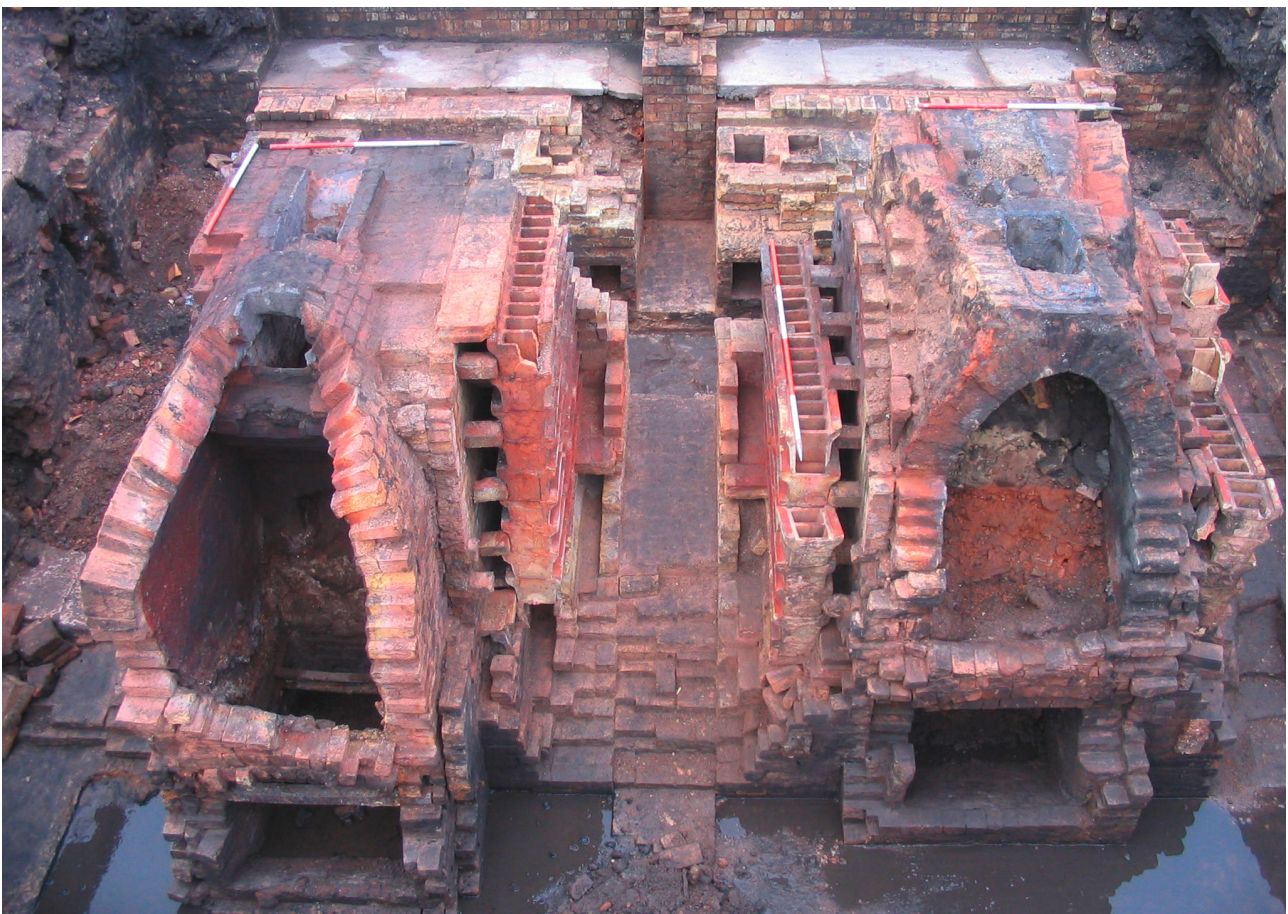

Illus 58 East elevation of two furnaces (J0045) and (J0046)



Illus 59 General view of brick base (J0050) from the south

features of each bench were ten coke ovens on the west side. These were 2m high, 1.05m wide and 1.6m deep (Illus 63). None retained the cast iron door that would originally have been attached to their front. The base of each oven (the ash pit) had an angled front and rear wall with the front of the pit extending 0.8m beyond the front wall of the oven. A shelf on the rear wall was set above the ash pit, over which a grate would have been positioned. At the top of the oven on the rear wall was a vent leading into the structure. Further corbelled vents were present at the top of the side walls of the oven leading to vents on the top of the bench. A

series of six vents was located on each side of the oven, which ran through the structure and could be left open or closed in order to regulate the flow of air. Below each of these, a small brick arch with a flue ran through the structure leading to the central flue. Each furnace was separated from the next by a brick wall that was not keyed into the main structure. At the base of each of these walls were square pits, which contained the remains of a cast iron support beam. These beams may have supported a frame for the oven doors and carried the weight of the heavy clay retorts above the coke ovens.



Illus 60 General view of retort benches from the south

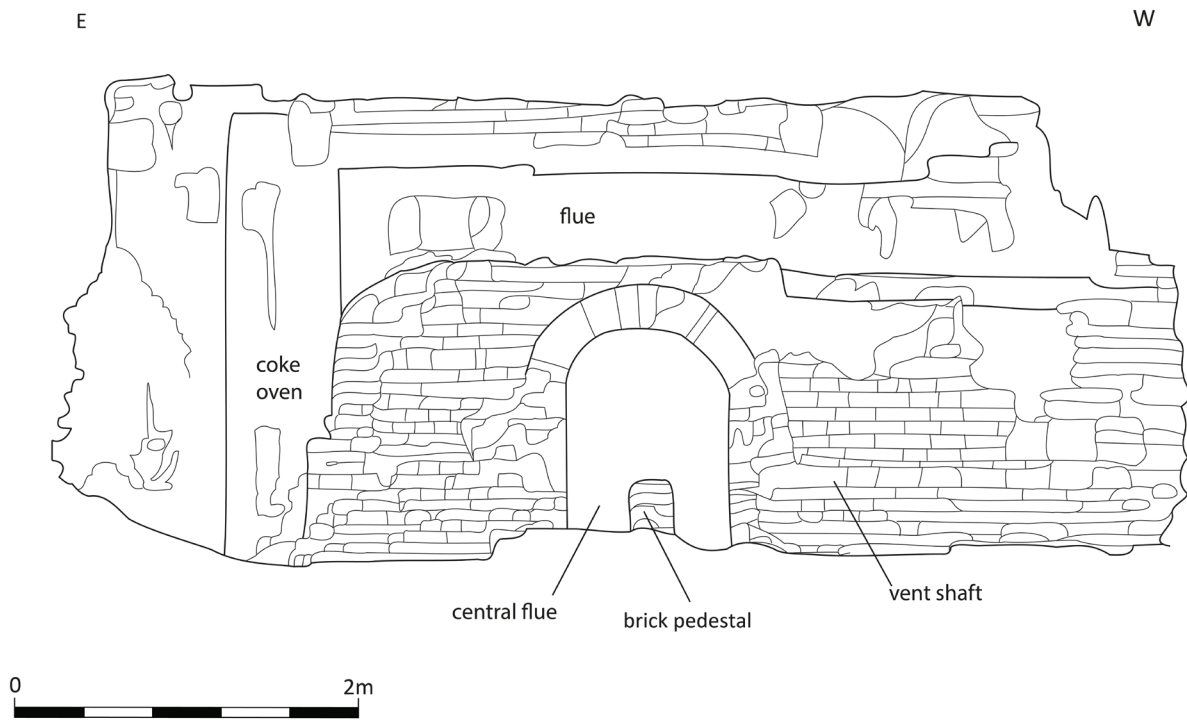

Illus 61 Section through retort furnace

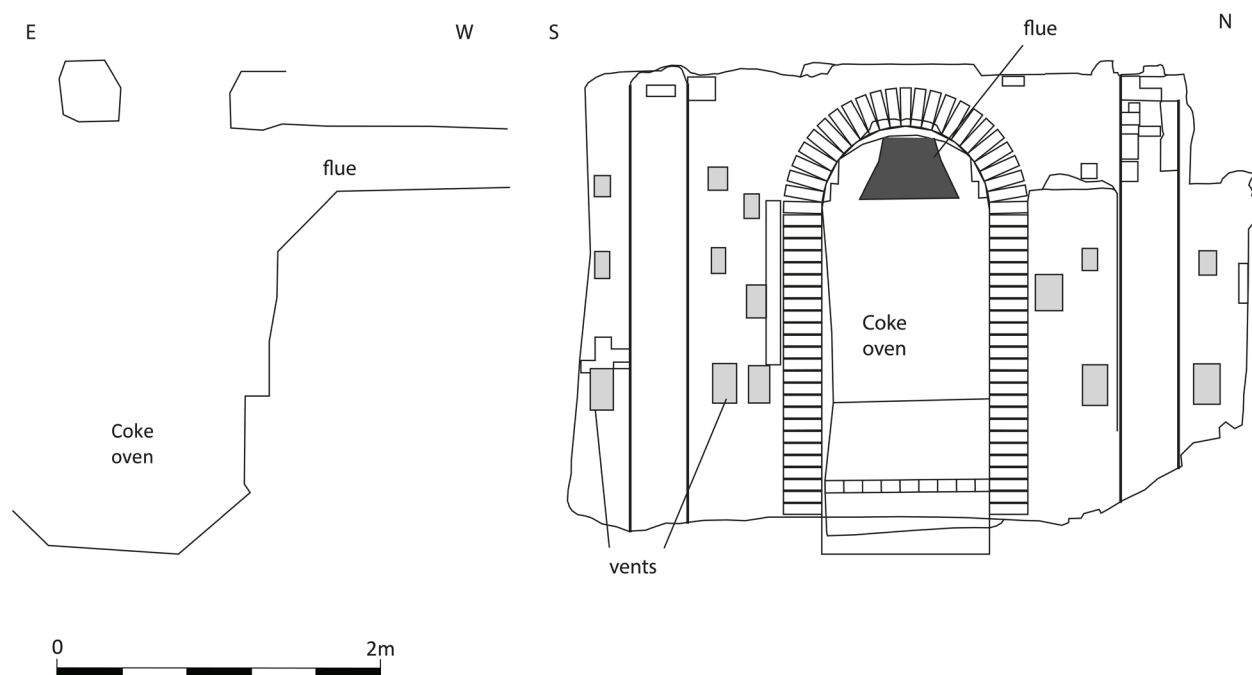

Illus 62 Front elevation of retort furnace

The rear elevations of the benches were consistent with two groups of seven small vents on each side of each furnace block and three small brick arched flues at the base. Again, a pit in the concrete floor at the base would have held a support pillar. The upper sections of the retort benches contained groups of east/west-aligned vents (Illus 64). The vents on top of the retort benches would have transferred heat from the coke ovens to the individual clay retorts above, only one of which (Illus 65) was recovered.

6.7.5 Retort flues

Running beneath the floor of the centre of the entire retort bench area was a north/south-aligned flue, 0.93m wide and 1.48m high. A low brick wall ran down the centre of the flue (Illus 66). Two gaps between the retort bench banks contained large east/west-aligned overhead flues, (C0026) and (C0030), between the coal shed wall (C0005) and wall (D0007) to its west (Illus 67). Flues (C0026) and (C0030) were constructed of firebrick encased in an iron plate sleeve and were internally

1.2m wide and 0.67m high. The northern flue, (C0026), was supported on a brick structure, (C0027) (Illus 68), with a large arched opening below the flue. Flue (C0027) ended between two side walls, (C0028), that continued beyond the furnaces, abutting the main north/south brick wall (D0007). At this point, a large vaulted flue, (J0333), continued through the wall – this may have been part of the Phase 3 complex as the Phase 4 flue system may be a modification of the Phase 3 system.

The overhead flue to the south, (C0030), was more heavily truncated, revealing its lower elements. The central flue through the retort benches was seen to form a junction with a flue leading off to the east and a more substantial flue to the west. The walls of the flue to the west, (C0034), abutted brick walls, (C0032), which projected from wall (D0007) and led to flues (J0306) and (J0307). Flue (J0306) stretched to the south towards Phase 4 chimney base (J0240), while flue (J0307) continued to the north, with a third flue, (J0189), stretching off to the west side towards the double furnace room. Several of these flues likely originated in Phase 3.



Illus 63 Detail of one of the furnace ovens showing the sloped base

6.7.6 Trolley line

Between the retort benches and east wall (C0005), the concrete floor incorporated a narrow trolley line, (C0002). At the north end it was a single track, 0.40m wide with iron plate sleepers. A second track turned off from the first to form two parallel tracks along most of the length of the retort benches. The tracks rejoined close to the south end of the retort bench area (Illus 69). These tracks aided the conveyance of coke to the ovens and the removal of residues.

6.7.7 The purifiers

Wall (C0005) to the east of the retort benches extended approximately 100m north/south and incorporated openings (C0013), (C0017), (C0047) and (C0049), which led to the coal sheds. To the west, north/south-aligned wall (D0007) again continued the full length of the retort benches. Immediately to the west of wall (D0007) was a complex of interconnecting rectangular brick features that were interpreted as potentially part of the purifying complex, though this could not be confirmed by the cartographic evidence. These



Illus 64 Detail of the top of one of the furnaces from the west



Illus 65 Detail of a clay retort



Illus 66 View through the central flue running through the retort benches

chambers ran parallel to the retort benches and were delimited by three north/south-aligned brick walls, (D0001), (D0010) and (D0007), 0.91m apart, and by east/west-aligned walls, (D0005), every 1.23m. The chambers were one or two courses high and filled with coke residue and burnt material. A 0.75m wide brick-lined drainage channel, (D0030)/(D0042)/(D0052)/(D0093), ran parallel and west of the chambers, with a branch at its north end running to the west, (E0024) and (E0091).

Nearby, stone mountings (D0053), (E0039), (E0079), (E0084) and (E0086) each comprised a large stone block (1.16m by 1.22m by 0.32m high) with four iron pins inserted. They may have supported pipes or an overhead rail system.

6.7.8 Possible workshops

In the north of the major 'Fire Department' building, a complex of brick walls formed three basement rooms with packed earth floors, possibly workshops. The northern wall of this block comprised earlier stone wall (F0001). The brick walls to the south

formed two rectangular rooms aligned north/south to the north, FA1 and FA2, with a third room, FA3, aligned east/west to the south. Wall (F0002) was the east wall of this complex, with (F0006) the south wall of room FA3. East/west-aligned wall (F0004), with an arched opening, formed the division between room FA3 and rooms FA1 and FA2, while wall (F0003) separated room FA1 from FA2. This wall included the remains of two brick arches, while the west wall of FA2 (F0005) included three brick arched openings.

6.7.9 Features to the west of the workshops

To the west of the workshop rooms were further Phase 4 features. In the north of this area was a concrete floor, (H0006), with the remains, (H0009), (H0011) and (H0012), of a large concrete block. The whole structure would have measured 4.3m by 3.6m in plan and included two east/west channels. Another feature in this area was a 0.11m-deep iron basin, (H0034), 2.04m long and 0.74m wide, of unknown purpose.



Illus 67 View of north overhead flue (C0026) from the west

6.7.10 Steam engine basements near retorts

There were two large steam engine basements, (J0006) and (J0111), in the east of the site, approximately 25m apart. The northern basement, (J0006), measured 5.5m east/west by 4m north/south and was 2.48m deep. Its walls were mortar-bonded yellow brick and its brick floor incorporated two brick engine supports (Illus 70). The larger of these, (J0007), measuring 2.3m by 2.23m in plan, was a U-shaped structure. Iron mounting bolts projected from the top of the structure, which would have held machinery in place above. To the south,

the smaller mounting, (J0008), measured 1.9m by 0.67m and had an iron pin at each corner. The southern machine basement (J0111) was identical to (J0006).

6.7.11 The southern chimney and its flues

In the south of the Gasworks was the base of a brick-built chimney, (J0240)/(J0241) (Illus 71), which was probably constructed during Phase 4. Measuring at least 6.8m long and 6m wide, this was a substantial feature. Its floor was constructed of concentric rings of bricks (one stamped 'GLENBOIG'). The chimney



Illus 68 View of the lower flue and support (C0027) from the north-east

interior was 3.3m in diameter and flues entered the base of the chimney from the east (J0306), west (J0313) and north (J0312). On each excavated side of the chimney were brick-lined shafts that formed part of a damper system to regulate airflow. The largest of these, shaft (J0269) to the north, measured 1m by 1.1m in plan and was flanked by two stone mountings, (J0238) and (J0311).

The three substantial flues (Illus 43) that emerged from the southern chimney, (J0306), (J0312) and (J0313), headed north to join the retort bench area and the major chimney in the centre of the Gasworks

(Illus 72). The eastern flue, (J0306), constructed of firebricks stamped with 'ETNA' and 'HURLL GLASGOW', eventually curved to the east through wall (D0007) where it formed part of the flue system running into the retort bench area, where it appeared to be built over flue (J0307), which extended to the north, joining a complex of further flues. Flue (J0306) was a substantial structure, its wall being 0.62m thick with a vaulted roof five brick courses thick.

Flue (J0312), which curved to the west to run alongside (J0313), though of a similar brick build,



Illus 69 View of the rail tracks to the east of the retort benches

was in places more substantial than (J0306), being up to 2.26m high with walls 0.75m thick. A white fibrous material acted as insulation within this structure. Where the structures of flues (J0312) and (J0313) joined, an internal wall separated the two flues (Illus 73) before dividing again. Flue (J0313) continued to the north and flue (J0312) turned east to join an earlier section of flue that continued into (J0307), where it linked with the southern overhead flue of the retort benches. It is possible that the northern section of (J0312) may represent the reuse of an earlier flue. Flue (J0313) continued

north beyond the double furnace room to join flues (J0332), (J0333) and (J0334). It was connected via damper structure (J0058) and flue (J0172) with the double furnace structure, (J0045) and (J0046). Flue (J0333), likely of Phase 3 origin, then joined the northern overhead flue in wall (D0007) to link into the retort bench area.

6.7.12 Boiler house

In the west of the major Gasworks building, a brick surface, (K0088), measuring 10m by 4m in plan, was defined by raised brick wall bases (K0039),



Illus 70 Engine mounting (J0007) from the west



Illus 71 Cobbles (J0248) and (J0249) abutting chimney base (J0240)



Illus 72 General view of the main flues at south end of Gasworks



Illus 73 Section through flues (J0312) and (J0313) as they join from the north

(K0080), (K0090) and (K0079). A north/south-aligned brick plinth, (K0089), stood in the centre of this area, measuring 8m by 1.92m in plan, and 0.65m high (Illus 74). The south wall, (K0090), included vents and a raised area of heat-affected brick, (K0093). This room appears to have held large horizontal tanks of a boiler house, marked on the 1915 plan of the Gasworks (Illus 9 & 56). Small brick enclosures, (K0107), with sloping brick edges on three sides were located to the east.

6.7.13 Structures south of the boiler house

In Area K, the southern wall, (K0090), of the boiler house continued as (K0051). It formed the north wall of a group of rooms defined to west and east by north/south-aligned brick walls. The north of the east wall of this building south of the boiler house was wall (K0258), a yellow brick wall base; it continued in truncated segments to the southern limit of excavation until wall segment (K0350). The wall segments were divided every 4m by stone mountings, (K0244), (K0259), etc, which had

shallow channels running from the centre to the west and projecting iron bolts. To the west, the wall of this building also extended to the south towards the end of the excavated area as (K0050), (K0348) and (K0346).

East/west-aligned yellow brick walls (K0160)/(K0163) and (K0212)/(K0179)/(K0337) formed partitions of this building (Illus 75). Wall (K0160)/(K0163) included a 0.70m wide gap for a cast iron pipe, where originally a small arch had existed. Another wider brick arch was recorded 5m to the west. The southern of the two partition walls, (K0212)/(K0179)/(K0337), also included two arches.

These brick walls formed three distinct areas or rooms. The southernmost room contained a complex of brick-walled cells, (K0185)–(K0211) (Illus 76). Two sets of 24 cells would originally have been present, formed by low brick walls; each cell measured 3.9m east/west by 1.1m north/south in plan. The gap between the two groups of cells contained a circular concrete platform, (K0284), 1.84m diameter. At the east and west ends of the northern group of



Illus 74 Brick base (K0089) from the north



Illus 75 General view of Area K from the south-west

cells, gaps occurred in the cell walls in line with the arched openings in brick partition wall (K0212)/(K0179)/(K0337) to the north. These respected the routes of pipe trenches which ran through the wall. The cells could potentially have formed a foundation support for a floor.

In the central walled area, to the north of the cells, against the north side of partition wall (K0179)/(K0337), were remnants of a granite sett floor, (K0158)/(K0336), laid over a concrete base, (K0242), with an intervening layer of latticed timber flooring (K0236) at its eastern end. The floor had been cut by two north/south-aligned pipe trenches, (K0100) and (K0162), aligned with the arched areas in the wall to the south.

In the west of this room was a rectangular north/south-aligned concrete platform, (K0373), set against wall (K0050) and partition wall (K0370). This platform, standing 1.09m high and measuring 18.2m by 2.7m in plan, supported four circular cement-covered brick bases, (K0374)–(K0377), which were each 2.43m in diameter. A white fibrous

material was recorded on these bases, suggesting that they had been insulated, although their use is unknown – they may have held cylindrical tanks.

To the east of this platform stood four large circular cement-covered brick bases (K0360)–(K0363) (Illus 77), which were each 2.9m in diameter. In the middle of the four bases was an associated Y-shaped brick channel (K0364). At the eastern edge of the concrete floor on which the tanks stood was a channel leading to the north, defined to the east by a low brick surrounding wall, (K0240), for two cement-rendered brick bowls, (K0273) and (K0239). These bowls were 1.44m in diameter, with concave bases, again perhaps for supporting tanks.

North of the area containing the circular platforms, brick wall (K0381) associated with a lined channel (K0424), extended to the north before curving to the west where it split into two separate channels that ran north through the partition wall (Illus 78).

These two channels led into the northern room of the building to the south of the boiler house. Against the western wall of this room, (K0050), was



Illus 76 Brick cells at south end of Area K

a large rectangular concrete platform (K0372), 6.1m by 2.75m in plan and parallel with and similarly constructed and aligned to platform (K0373) to its south. It had five sets of projecting iron pins and stood over walls of the eastern of the parallel rectangular Phase 2 buildings. To the east, two large concrete blocks with irregular brick surrounds, (K0302) and (K0304), formed the bases of machine mountings, with projecting iron pins. The walls surrounding these blocks were continuations of the brick channels located to the south. To the east of each of these mountings were concave recesses, interpreted as wheel pits.

To the north of the engine mounting blocks was another large brick platform, (K0303), set on a thick concrete plinth. Two L-shaped structures formed a large U-shaped platform, 7m east/west by 2.5m north/south and 1.15m high. The platform incorporated a series of projecting iron bolts, suggesting it was another machine mounting. A narrow wall formed a 1m wide channel along the south side of this platform.

6.7.14 The 'Purifying House'

In Area N, to the west of brick wall (K0050)/ (K0348), and in the location of the Phase 2 western rectangular 'Gas Holders' and 'Purifying House' building, a former southern room contained truncated remains of two groups, originally of eight brick-lined cells though reduced by truncation to six in one instance, (N0022 a–h) and (N0082 a–f). This has been interpreted as belonging to Phase 4. Each cell measured 3.46m by 1.11m in plan and was 1.57m in height with three large brick pillars (N0049)–(N0051) standing between the cell groups. Another set of smaller brick cells, (N0088), was recorded in the north-west corner of this room. The cells were interpreted as supports for a floor or other structures. On excavation, a very strong ammonia smell was apparent in this area, and the 1915 plan indicates that this formed an element of the extensive purifying house (Illus 56).

Beyond the east/west-aligned stone walls, (N0020) and (N0021), which formed a long-lived partition



Illus 77 Brick and cement bases (K0360)–(K0363)



Illus 78 Brick-lined channels to the north of the circular bases

to the north of these cells, a series of 3.5m high red brick walls, (N0023)–(N0030) were recorded, while further brick walls, including (N0092), (N0098), (N0102) and (N0103), stood to the north and west, forming a grid pattern. Again, these walls may have formed a foundation for a floor or other structure. Further east/west-aligned brick walls, (N0120)/(N0122) and (N0150), approximately 30m in length, supported by brick buttresses, formed a basement corridor or pipe channel.

6.7.15 Lift shaft and corridor

To the north of the building identified as a purifying house was a substantial east/west-aligned brick structure, (N0154) (Illus 79), measuring 11.6m by 4.5m in plan and 2.9m in height. The 1.26m thick walls defined two separate areas: a square lift shaft (internally 1.8m square) to the west and a corridor to the east. A brick-lined shaft, (N0155), was attached to the western external wall of the lift shaft, probably to house a counterweight. An arched opening led east from the lift shaft into the attached corridor.

6.7.16 Flues in the west of the Gasworks

North of the lift shaft, brick flue (N0176) ran west into a square brick vent, (N0115), with a cast iron cover, (N0113), and a narrow vent with a smaller cast iron cover, (N0114). This abutted brick vent/shaft (N0111) to the north. To the east, flue (N0176) was overlain by brick vents, (N0233) and (N0234) (Illus 43). The flue continued to the east as (N0229) and as walls (N0231) and (N0232) and possibly joined north/south-aligned flue (N0075)/(N0275), into which several cast iron caps had been inserted, (N0259)–(N0262). A further section of possible flue wall, (B0093), was recorded to the north beyond wall (N0240), though this could be associated with Phase 3 structure (N0247)/(N0248)/(N0249) (see above).

6.7.17 Features to the north of the major Gasworks buildings

To the north of the north wall of the major 'Fire Department' building, (C0039), was a series of



Illus 79 General view of the lift shaft and corridor (N0154) from the west

red brick vents, drains and walls. Some of these features were possibly part of earlier phases. Brick walls (B0008) and (B0012) lined up with a square opening in the stone wall opposite the end of the retort bench furnaces. A large brick and concrete machine base, (B0044), aligned east/west, had eight iron pins projecting from its top and a square cut recess at its east end. To the north of this were two additional stone mountings, (B0048) and (B0049), again with iron pins. A further machine base, which included surviving timber beam fixtures (B0052), was located immediately to the west. Further brick walls and bases were recorded to the west, together with another brick-built vertical vent, (B0093), a section of concrete floor, (B0087), and a brick platform, (B0086).

6.7.18 'Tar House'

Iron tanks recorded in the north of the site formed part of the 'Tar House', depicted on the Ordnance Survey map of 1877. This element of the Gasworks, situated over the former location of the Phase 3 'Gas Holder', was marked by heavy contamination. Three iron plate tanks, (R038), (R039) and (R043), were recorded, each 1.5m deep and containing a mixture of shale and oily liquid. To the south of these tanks but within the same building, a brick wall, (R022), enclosed a complex of 15 brick cells (R027), 6m by 3m in plan, aligned east/west, and set over a brick and concrete base, 0.6m deep. It is possible this formed the foundation platform for a feature of the tar house, or of the two sets of condensers marked on the 1877 Ordnance Survey map.

6.7.19 Condensers or early boundary features

Two north/south-aligned stone wall base segments, (R018) and (R004), could potentially have been elements of boundary walls of the early Gasworks, as the area to their west was probably not incorporated into the Gasworks until its expansion in the 1840s. However, their cement bonding suggested that they belonged to the Gasworks and it is more likely that they were walls for the condensers depicted on the 1877 Ordnance Survey map (Illus 20). Wall (R004) stood to a maximum height of 1.4m, and was 0.8m wide and 8m long, while wall (R018), to its west was 10m in length.

6.7.20 Gasholder and tanks

A second gasholder base, (R016), of likely Phase 4 date, was recorded in the north-west of the site, one of those first depicted on the Ordnance Survey map of 1877, while nearby two large cast iron tanks were also recorded, (R011) and (R034). Tank (R011) was housed within a rectangular brick structure (R033), while a similar structure, (R028), measuring 4m by 2.5m in plan, was recorded between these two tanks.

6.8 Phase 5 (1906–1928)

When the Gasworks went out of use and was subsequently demolished in the early 20th century, written evidence suggests the area was turned into a park with a cinder football pitch, though no archaeological evidence for this was recorded (Baird 1959). The Gasworks structures were demolished and levelled, evidenced by the infilling of many of the deeper features with brick and stone rubble. The buildings of the Gasworks were demolished down to the ground floor level and cobble surfaces survived over much of the site along with the lower half of the retort furnaces and basement level features.

6.9 Phase 6 (1928 onwards)

The only archaeological features to clearly post-date the Gasworks belonged to the New Street Bus Depot that occupied the area until the beginning of the 21st century. The depot was largely demolished prior to the archaeological excavations but was recorded as part of a previous programme of work (Trickett 2005). However, 25 roof support foundation pillars were recorded during the excavation across the south and centre of the site, aligned in four rows running north/south in line with the pitched roof. Each of these large brick pillars was topped with a large concrete block. The pillars generally measured 1.75m by 1.60m in plan and they were between 2.5m and 3m in height. To the north, further concrete foundation blocks associated with the bus depot were identified, with some up to 2.5 metres square and 0.5m thick.

Further features attributed to the bus depot were five sections of concrete flooring that were interpreted as the bases of inspection pits, the side walls having been demolished. Two of these, (J0004) and (J0005), were aligned east/west and measured 6.95m by 1.0m in plan and were approximately

0.15m thick. Both floors contained a small sump area, each with an iron cover and surrounded by the remains of a brick wall. Two large cylindrical fuel tanks, (N0182) and (N0183), also belonged to the bus depot. These tanks, in the west of the excavated area, measured 9.5m in length and 2.5m in diameter and were enclosed within brick walls, (N0181). Drainage channels, such as (D0037)

and (H0007), and associated manholes, (E0004), (D0143), (H0039) and (G0022), which ran north/south across the site, were also associated with the depot. The works in the north of the former Gasworks revealed two brick walls, (R055) and (R056), associated with the bus depot (Illus 38); several further short segments of brick walls, (R008), (R009), (R010) and (R029), were also recorded.

7. TAPHONOMY OF THE BACKLAND SOILS

Lynne Roy

7.1 Introduction

The archaeological works in the New Street Gasworks site revealed post-medieval backland soil buried beneath the 19th-century Gasworks infrastructure. Four samples from the excavation were assessed in terms of their ability to further elucidate site formation processes and on-site occupation activities and one was selected for micromorphological analysis.

The analysis of microstratigraphy and microstructure of the archaeological sequences and examination of the relationships among construction features, sediments, and their archaeological findings is essential for interpreting natural depositional processes and palaeoenvironmental changes (Karkanis & Goldberg 2007: 63), human-induced soil formations and

disturbances, land management and the use of space and structure of sites (Matthews et al 1997).

7.2 Stratigraphy

The in situ post-medieval backland soil deposits occurred at various depths between 39m and 42m AOD (Engl & Bailey 2006). This compared with the maximum recorded depths of 41.25m AOD for backland soil beneath the Waverley Station Vaults site to the west and 38m AOD for backland soil within the area to the immediate east. The natural subsoil or bedrock, underlying the archaeological deposits, varied from 2.9m (39.7m AOD) to 4.0m in depth (38.6m AOD).

7.3 Methodology

One sample was prepared for analysis using the methods of Murphy (1986) at the University of Stirling in the Department of Environmental Sciences. The thin

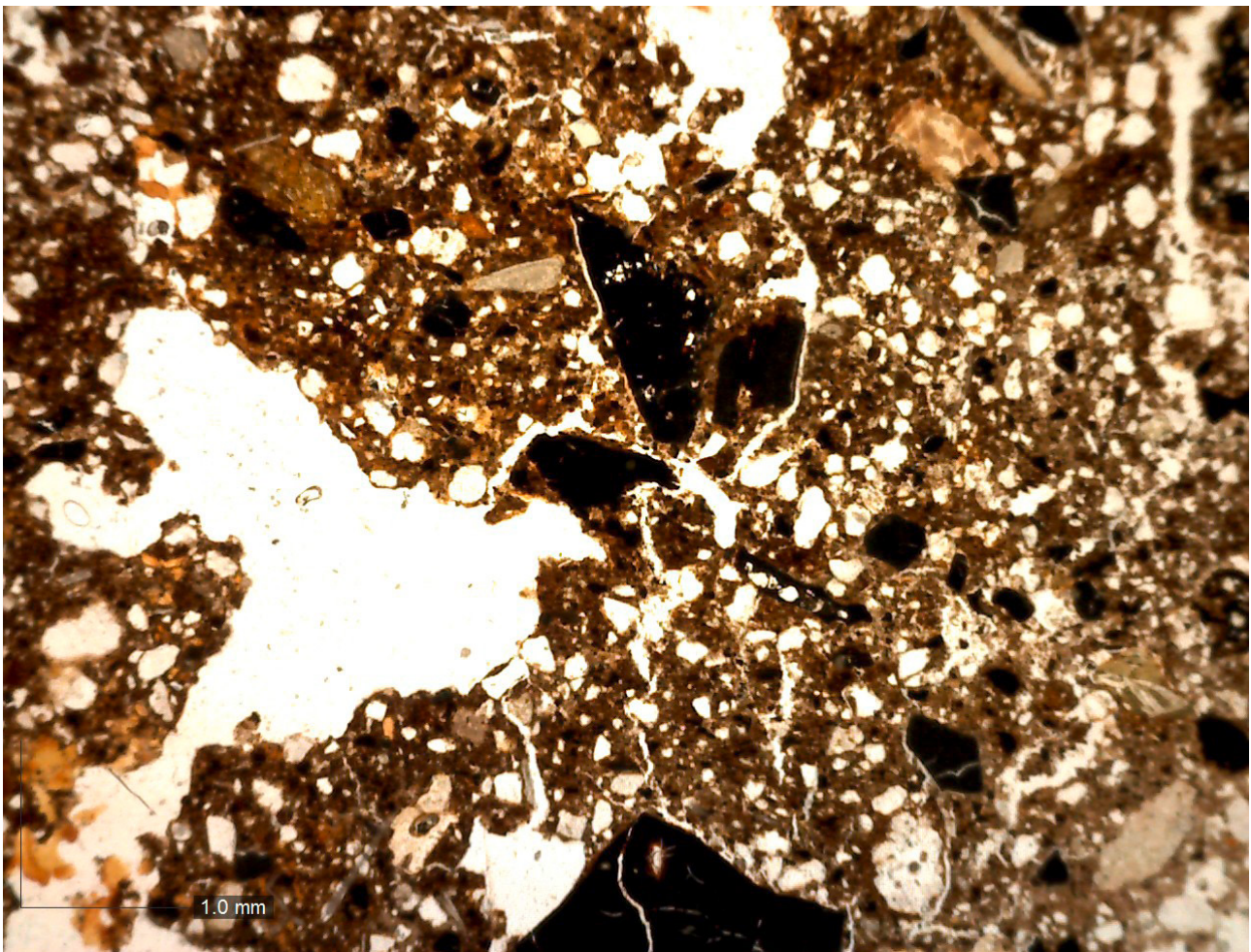

Illus 80 Channel and chamber microstructure Unit 1

sections have been described using the terminology of Bullock et al (1985) and Stoops (2003). The coarse/fine limit of 10µm is used for both the mineral and organic components. Samples were observed in plane polarised light (PPL) and cross polarised light (XPL) at magnifications of ×50, ×100, ×200 and ×400. Thin section description was conducted using the identification and quantification criteria set out by Bullock et al (1985) and Stoops (2003), with reference to MacKenzie & Adams (1994) and MacKenzie & Guilford (1980) for rock and mineral identification, Fitzpatrick (1993) for further identification of plant material, and Schweingruber (1978) for identification of charcoal. Full details of the methods used are described in the archive report (Roy 2018).

7.4 Results

The sample was found to comprise two broad microstratigraphic units distinguished on the basis of

observed difference in porosity and size and quantity of exotic components. Unit 1 is contained within the base of the sample and in thin section it was observed to consist of a mixed heterogeneous sediment. The microstructure is complex and locally variable and includes massive and channel and chamber (Illus 80). Fine material comprises fine dark brown organic coatings to mineral grains and fine charred material which occurs between the sand grains. Organic inclusions comprise few individual reddish-brown cells with very few poorly preserved plant tissue and organ fragments, frequently with only the outer lignified tissues remaining. Few internally amorphous black probable charred fragments are distributed throughout the matrix. A single charred cereal grain was also identified. Observed pedofeatures include the aforementioned organic coatings and occasional dusty clay and silt coatings to voids.

Unit 2 is present within the upper 30% of the sample, where it had a diffuse boundary with the

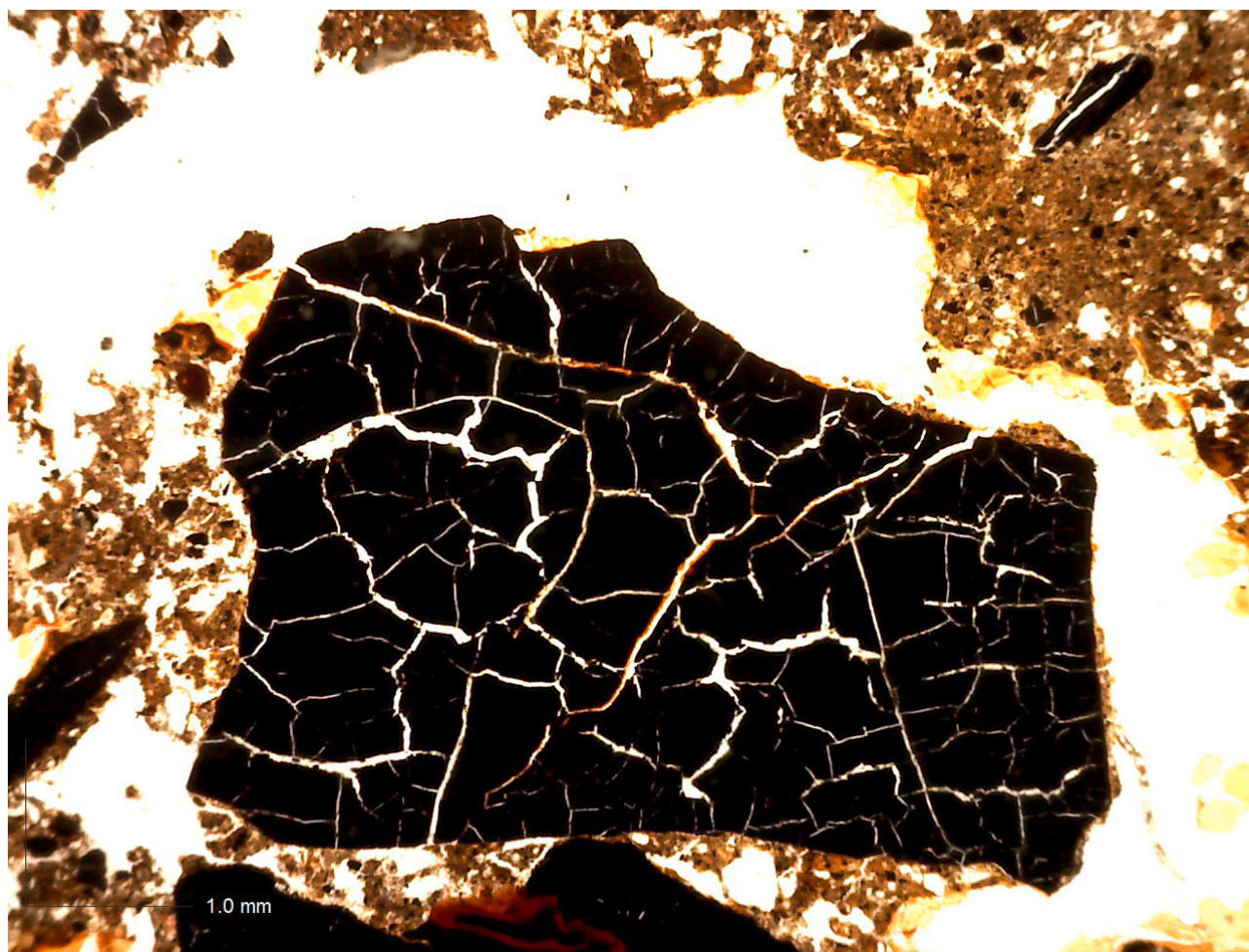

Illus 81 Probable charred peat fragment with yellow clay staining to voids

underlying unit and was distinguished by its darker colour and higher proportion of organic material (charred and uncharred). The context was a poorly sorted sand deposit with a complex microstructure of 5% to 10% unaccommodated channels and vughs with undulating void walls and locally weakly separated granular microstructure. The unit contained frequent charred plant material including common opaque fragments of cellular charcoal and amorphous blackened charred and cracked organic matter which may be burnt peat (Illus 81). Frequent silt, very fine sand and fine sand-sized black particles were probably comminuted charred particles. Observed pedofeatures were limited to rare brown typical Fe/Mn nodules (50–500µm) and rare dusty and silty coatings to voids.

The mineralogy of the sand grains and lithology of the rock fragments from throughout the sample sequence represent a soil parent material, sandy soils derived from colluvial deposits overlying sandstones (Bown & Shipley 1982), present over much of the surrounding area. Minerals are often present as individual grains and mineral aggregates. Observed rock fragments are predominantly of sedimentary type (see MacKenzie & Adams 1994). In both units quartz grains dominated the coarse mineral (>10µm) component of the sample with feldspars commonly present. The grains were predominantly sub-angular to sub-rounded and randomly distributed throughout the matrix. The most abundant grain size in all samples was medium sand (200–500µm) to coarse sand-sized (500–1000µm) quartz grains. Other minerals present in the samples included feldspars biotite, mica and chlorite, each of which constitute <2% of the coarse mineral content. No patterning or significant variation in mineral content was observed within the sample. No erratics introduced by human occupation were observed within the sample.

A high degree of bioturbation within both units was observed, as indicated by reworked fabric and the random, occasionally clustered, distribution of natural and anthropogenic components. Fragmentation by biological activity in the soil was visible in the large quantity of finely comminuted charcoal and pedofeatures and inclusions dissected by post-depositional channels.

The sample had a largely undifferentiated b-fabric, likely because the dark amorphous organic matter

staining masked the interference colours of the clay. The birefringence of the fabric was low. Phytoliths were rarely observed and where seen were generally disarticulated and poorly preserved, preventing identification of type, although their presence was generally indicative of grass vegetation. Both layers contained large quantities of charred amorphous fine organic matter including fine charcoal which obscured visibility within the groundmass.

Observed anthropic indicators within both units included cellular wood charcoal, charred sediment, and burnt and unburnt mammal bone. Within Unit 1 at the base of the sample, a cluster of blackened nodules with vesicular structure was found (Illus 82), which has likely developed during burning composed of incompletely burnt carbonaceous matter, formed from characteristic vesicular lumps indicative of the coal-burning process (see Canti 2017: 144–5). Sub-angular and sub-rounded fragments of isotropic dark glass featuring possible olivine crystals are likely fragments of slag (see Angelini et al 2017). They have vesicular porosity, which is derived from bubbles of gas trapped during the heating process. Rounded droplets of slag, *c* 200µm in diameter, were also observed. A single charred seed was also identified at the top of Unit 1. Anthropic indicators within Unit 2 also include pottery fragments, clay pipe and fish bone.

Iron and manganese replaced organic material within localised areas of the sample. The observed chemical changes appeared to be localised and possibly reflect variations in the acidic anaerobic and damp conditions required for them to occur.

7.5 Discussion

Early maps show the largely undeveloped nature of the Canongate backlands until the late 18th century. The sample was removed from an area shown as gardens or perhaps lightly cultivated horticultural or orchard ground. Dusty clay coatings such as those observed within the sample are commonly associated with agriculture and ground clearance activities and thus are consistent with the land use shown on early maps. Clay coating features are explained by Jongerius (1983) as derived from the splash effect of the rain on a bare surface, most often cultivated. In a forest context, the combination of the local deforestation and the rigorous preparation

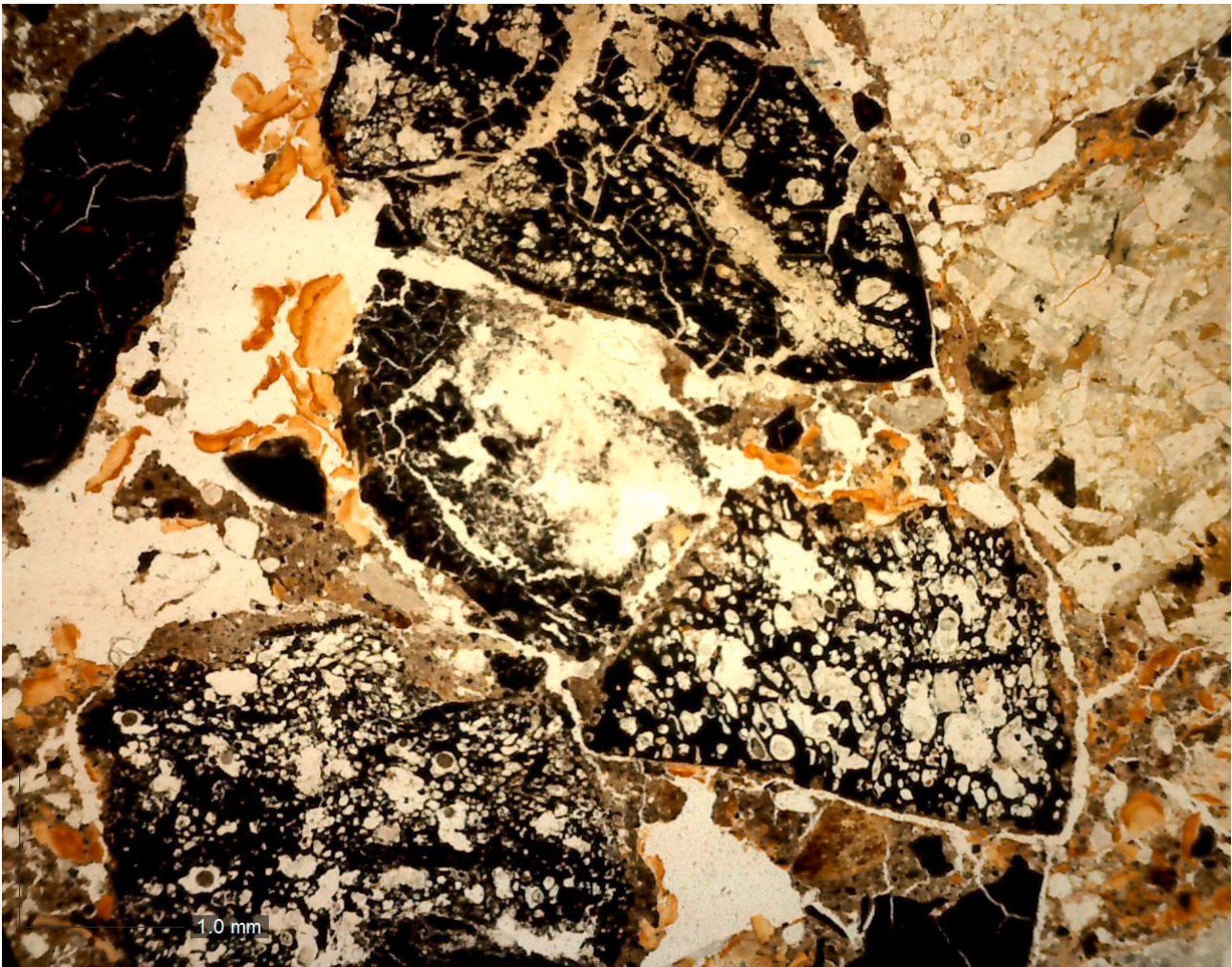

Illus 82 Vesicular melted charred materials – possible coal

of the soil surface (levelling, digging, trampling) necessary for charcoal burning would generate a periodic long-term bare surface conducive to dusty clay coating and intercalation formation. Marked iron and manganese staining within the upper unit indicates the context to be a relatively poorly drained soil, high in organic matter and affected by some groundwater gleying. These characteristics are indicative of podsol formation and also indicate that the site was located within an open vegetated area in damp conditions

The anthropic components identified micromorphologically suggest that domestic refuse or fuel may have been added to the soil. This would be consistent with a cultivation soil that has been deepened either by the deliberate addition of mineral material as manure or by the dumping of domestic waste. The loose well-separated microstructure reflects the dumping of material testified by the

juxtaposition of reworked aggregates with different origins.

The identification of two distinct microstratigraphic units within this single sample is reminiscent of a dark earth, ie the outcome of pedogenetic transformations acting on originally well-stratified urban archaeological deposits. The sample thus represents a palimpsest of different activities and natural processes. The upper unit is increasingly organic, with evidence for more intensive biological activity giving an increasingly pelletal structure towards the top of the profile and indicating that this deposit was left open to the elements for sufficient time to allow for partial reworking and homogenisation. The frequency of charcoal also decreases upwards. These changes are indicative of a change in anthropic influence on this deposit, possibly reflecting a slight change in activity in the immediately surrounding environs.

The presence of anthropic indicators such as slag throughout the profile (particularly in the upper unit) is indicative of nearby industrial influences. Dennison suggests that in the 17th century craft and trade activities in the vicinity of the site were extensive and that ‘the craftsmen of Canongate continued to outnumber merchants since the burgh now functioned very much as a manufacturing suburb of Edinburgh’

(Dennison 2005: 98). The identified exotic industrial components within the sample contrasts with the backland soil analysis at the nearby Waverley Vaults site, where the only identified anthropic indicators comprised charcoal (Fouracre 2007). The inclusion of slag, pottery, clay pipe and burnt and unburnt bone noted here are indicative of a deposit influenced by nearby occupation and possibly industry.

8. THE ECOFACT EVIDENCE: NEW STREET GASWORKS

Jackaline Robertson

8.1 The animal bone

8.1.1 Introduction

Excavations at the New Street Gasworks site recovered a limited quantity and range of animal bone remains (3.28kg). The majority of the assemblage (2.3kg) came from test pits excavated in the northern area of the Gasworks footprint.

8.1.2 Methodology

The assemblage was identified to element and species with the aid of skeletal atlases (Schmid 1972; Hillson 1986) and the reference collection stored at AOC Archaeology Group (Edinburgh). Where an element could not be identified to species, it was instead described as large mammal (horse/cattle/deer), medium mammal (sheep/goat/pig) or small mammal (dog/cat/rodent). When analysing the assemblage, the following criteria were recorded: phase, context, feature, element, species, side, fusion, age, fragmentation, size, and evidence of staining on the bone surface.

Epiphyseal fusion, tooth eruption and wear were examined to assess the age of the individual (Silver 1969; Payne 1973; Grant 1982; Payne 1987). The proximal, distal and shaft areas of each fragment were recorded to determine the level of fragmentation within the assemblage (Dobney & Rielly 1988).

8.1.3 Results

The bone assemblage was small: 324 fragments (2.98kg) were recovered by hand from 28 contexts across the excavated area. A further 654 fragments (298.1g) from bulk soil samples were also recovered but none was larger than 50mm and preservation was noticeably poorer when compared to the hand-retrieved material. The domestic animal species identified were cattle (34), sheep/goat (41) and pig (3). The remaining fragments were large mammal (159), medium mammal (78), small mammal (6) and indeterminate mammal (654). There was also domestic fowl (3) and fish (8). The fish remains were

a mix of vertebrae and ribs and are not mentioned further in this report. Preservation of this assemblage widely ranged from mostly poor to excellent. Poor preservation was due to soil conditions, weathering and prolonged exposure to the elements. These remains were scattered across the site with no evidence of selective or purposeful disposal.

8.1.4 Discussion

Thirty-four fragments of cattle bone included a mix of teeth, horn core fragments, long bone and foot bones, and were recovered from 19 contexts. The bones represented a minimum of four individuals. The youngest individual died before the age of 10 months, whereas the eldest expired between the ages of 3.5 and 4 years.

A total of 41 bones were identified as sheep/goat from 19 contexts, with a notable concentration in deposit (N0105). The skeletal elements were identified as loose teeth, pelvis fragments, long bones and foot bones, which represented a minimum of eight individuals. One individual was noted in context (K0000) and was found to be older than 18 months. The remaining individuals were older than 10 months in age, the oldest being one from deposit (N0105) which expired between the ages of 13 and 24 months. Further bones, identifiable only as large mammal and small mammal, were also present.

Pig remains were scarce, although a single burnt canine and an unstratified radius and femur from an animal aged between 1 and 3.5 years at the time of death were recognised. Small poorly preserved bones of at least one domestic fowl were also noted but the state of preservation prevented close identification.

Butchery marks were observed on 20 bones identified as either cattle or pig, large and medium mammal, including four cattle phalanges which displayed evidence of marrow cracking and chop marks, while a large mammal mandible had four shallow skinning marks on the surface. Evidence of chopping, sawing and cracking of bones can be related to initial butchery marks, while the shallow knife cuts noted are likely to be the result of de-fleshing during skinning. None of these skeletal elements displayed any obvious evidence of pathologies or trauma, but gnawing marks, probably by rodents, were noted on two bones from deposit (K0000).

8.1.5 Conclusions

The animal bone assemblage, while small, is similar to other post-medieval sites in Edinburgh such as Advocate's Close (Robertson 2017). The animal bone from this site had accumulated through the haphazard disposal of domestic food and butchery waste. Beef, lamb, mutton, pork and chicken all had a role within the diet of the urban population living in this part of Edinburgh.

8.2 The macroplant remains

8.2.1 Introduction

A total of 67 macroplant remains were recovered from eight contexts. In addition, seven poorly preserved cereal caryopses were recovered from soils collected during test pitting in the northern area of the New Street Gasworks. These plant species were preserved through carbonisation and mineralisation. Preservation of the assemblage ranged from poor to good.

8.2.2 Results

The carbonised macroplant remains consisted of 27 charred cereal caryopses identified as barley (*Hordeum* sp), hulled barley (*Hordeum vulgare* L), bread/club wheat (*Triticum aestivum/compactum* L) and oat (*Avena* sp). Most of these were in a poor state of preservation; some were oxidised and displayed surface abrasions due to the polluted and corrosive composition of the sediment. The cereal caryopses were found as a light scatter, infiltrating various negative features across the excavated area; no concentrations were recognised that would suggest selective or deliberate disposal.

Also present were the mineralised remains of 47 fruit seeds identified as grape (*Vitis vinifera* L), fig (*Ficus carica* L) and raspberry (*Rubus idaeus* L). These seeds were concentrated within deposit (N0105), while a single grape seed was noted in drain (K0174).

8.2.3 Discussion

The cereal assemblage is broadly similar to other post-medieval and modern sites in Edinburgh in terms of the species represented, the quality of their preservation and the quantity of material recovered.

This includes assemblages from Advocate's Close (Robertson 2017) and Jeffrey Street (Haston quoted in Masser et al 2014: 46). Such small quantities of cereal grains are indicative of post-medieval and later urban assemblages where the population was typically consuming products produced from pre-milled flour rather than stockpiling grains for grinding on site.

The mineralisation of the grape, fig and raspberry seeds implies that they were components of faecal matter. The grape and fig are exotic imported food items, whereas raspberry was grown locally. Grape has previously been recorded at Jeffrey Street (Haston quoted in Masser et al 2014: 46).

This small assemblage indicates that the people living in the vicinity of New Street had access to cultivated cereals, a limited range of exotic imported foodstuffs and locally available fruits.

8.3 The shell

A small assemblage of marine shell was recovered from possible medieval/early post-medieval backland soils as well as structures, drains and other features related to the 19th-century Gasworks. A total of 178.1g of shell was found in the northern area of the excavation while 127.2g came from the Caltongate South New Street Gasworks excavations. Full details of the methodology used to identify and record the assemblage are outlined in the specialist report presented in the site archive.

A total of 14 shell fragments were recorded from Test Pits 1, 2, 4, 5 and 7 across the north of the Gasworks, while 33 fragments came from contexts (K0316) and (N0105). The assemblage was dominated by the common oyster (*Ostrea edulis* L) and common periwinkle (*Littorina littorea* L), but small quantities of common mussel (*Mytilus edulis* L), common limpet (*Patella vulgata* L) and common cockle (*Cerastoderma edule* L) were also recognised. Preservation of these finds ranged from adequate to mostly good. All the shell species identified are edible and are typically found around the Edinburgh coastline (Hayward et al 1996).

The shells either derive from domestic food waste discarded as general rubbish within midden deposits or were utilised as a building component.

9. THE ARTEFACT EVIDENCE: NEW STREET GASWORKS

9.1 Introduction

Large quantities of artefacts were found during excavations at the New Street Gasworks site, including metal, wood and stone fittings, fixtures and tools; painted architectural mouldings; a refractory ceramic retort and window glass fragments relating to the dismantled Gasworks complex; leather shoes; worked bone and metal dress accessories and personal objects discarded or lost by the employees of the Gasworks; and glass bottles, tableware and ceramics that can be related to the general occupation of the area both pre-dating and during the operation of the site.

Interpreting the significance of individual objects is problematic. The above-ground structures were dismantled and demolished during the early 20th century, and the area was levelled to make way for the construction of a bus depot. Most of the artefacts were recovered either from demolition or levelling deposits, which infilled basement rooms, passages, furnaces and other features. This process of demolition and levelling has resulted in considerable mixing and dispersal of material across the excavated area and it has been impossible in most instances to stratigraphically relate individual objects to particular buildings or features across the site.

Due to the large quantity of material recovered, the assemblage will be discussed by material type, highlighting items of particular significance that can be confidently related to the pre-Gasworks occupation of the Canongate and objects associated with the workings of the Gasworks itself. Individual catalogue descriptions are presented for illustrated items only; full catalogues and specialist reports which discuss the various components of the assemblage are presented in the site archive.

9.2 The architectural plasterwork

Diana Sproat

9.2.1 Introduction

Two fragments of architectural plasterwork (SF100 and SF101) were recovered from an unstratified deposit relating to the levelling of the Gasworks complex (Illus 83).

9.2.2 Analysis and description

The two fragments are contemporary and share the same architectural design and paint colour remains. SF101 is the larger and more complete example of the two, despite obvious wear to the base and rear. Table 1 summarises each piece:

► **SF100.** This fragment survives in a much poorer condition than SF101, with only the thicker upper part of the moulding surviving. The surfaces are covered in an uneven white lime plaster with another darker off-white cream plaster adhered to it with occasional grit fragments (<1mm in size). The outer surface contains the remains of a roundel, 16mm in relief from the main body.

► **SF101.** The rear and insides of this moulding have crumbled away unevenly with the same make-up of white lime plaster and the darker off-white cream plaster as seen in SF100. The moulding to the outer face has largely survived, the roundel at the 'top' of the piece damaged slightly to one side. The 'outer' side of the face has two thin mouldings 11mm in width with an inner square lip of 14mm projected from the main body of the piece by 10mm. The underside of the moulding is very smooth, a shallow S-shape, with the survival of a thin mould to the outer side 10mm in width. It is likely that there was a similar moulding to the inner side, although the surface has not survived.

Table 1 Properties of architectural mouldings, SF100 and SF101

SF no.	Weight	Surviving length	Surviving width	Surviving height
100	1,792.82g/1.793kg	210mm	165mm	90mm
101	3,230.30g/3.23kg	270mm	215mm	100mm

101

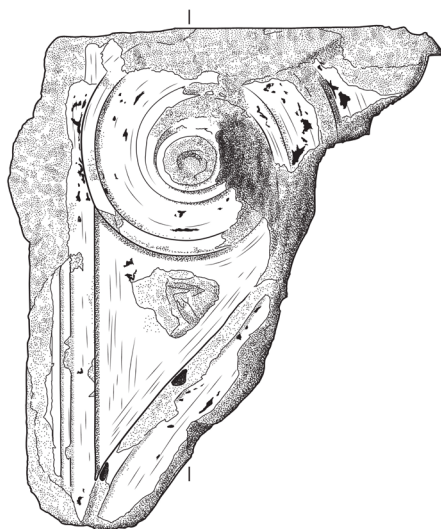

100

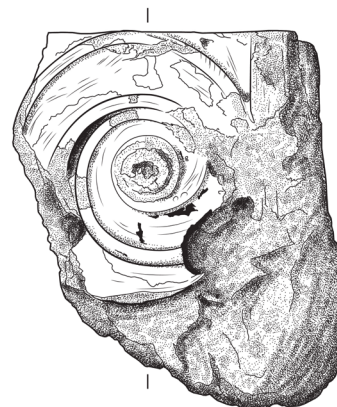

Illus 83 Moulded architectural plasterwork, SF100 and SF101

9.2.3 Discussion

The shape and design of the mouldings suggest that these were most probably two console brackets supporting a pediment over a doorway; they are of a typical 19th-century design for this type of feature. The outer surface of the moulding is defined by a roundel design at the top, approximately 135mm in diameter, set in a roughly triangular raised moulding, the fine outer detailing of which can still be seen on SF101.

They would have been placed with the roundel

pattern at the top with the curve to the outside of the doorway, the rear side of the moulding attached to the wall. The underside of the brackets here are relatively plain, with only a thin bead moulding still visible on the left side of the base of SF101.

It is likely the pieces are made up of lime plaster or gypsum plaster, which gives it its distinct white colour. The fragments of paintwork on the mouldings suggest at least four paint schemes throughout their lifespan, including a light beige, dark beige, light red and (the uppermost layer) a dark brown.

9.2.4 Conclusions

The decorative moulded plaster probably formed a pair of console brackets supporting a pediment over a doorway. Their design suggests that they may have come from an office building rather than an industrial building associated with the Gasworks. However, decorative elements to industrial buildings were not uncommon in the late 18th and early 19th century and so it is possible that the fragments belong to a building associated with the industrial process or, at least, an ancillary building.

9.3. The ceramic retort

Ian West

9.3.1 Evolution of gas retorts

The very earliest retorts were made of cast iron but the high temperature in the furnace caused them to deteriorate over time, often giving an operational life of a year or less. Retorts made from fireclay (ceramic retorts) were first tried in the 1820s and found to be cheaper to make and more long-lasting (up to three years, provided they were not subject to frequent temperature cycling), but they tended to be more



Illus 84 Retort bench with eight retorts, Fakenham Gas Works



Illus 85 Drawing horizontal retorts, South Metropolitan Gasworks, c late 19th century

porous than cast iron. The early gasworks relied on the pressure created by heating the coal to force the gas through the rest of the plant and out into the pipe network, so the significant positive pressure in the retorts caused gas to leak into the furnace from ceramic retorts, which limited their adoption. By around 1850, most larger gasworks introduced steam-power pumps, known as exhausters, to suck gas through the plant, so the pressure in the retorts was no longer elevated. This allowed ceramic retorts to become almost universal, except for small private gasworks which did not use exhausters.

Most small and medium-sized gasworks continued to use horizontal retorts throughout their operating lives, filled ('charged') and emptied ('drawn') by hand. The retorts were usually arranged in groups of between three and nine, at varying heights within the furnace, an arrangement known as a retort bench (Illus 84).

Charging and drawing retorts by hand was an

arduous task, made unpleasant and unhealthy by the heat and fumes in the retort house (Illus 85).

9.3.2 Retort design and manufacture

The earliest cast iron retorts were about 1m in length and circular in section. However, it was discovered that elliptical or, more commonly, D-shaped retorts performed better in extracting gas from the coal and, with a few variants, these shapes remained in use for both iron and ceramic retorts until the end of the coal carbonising era (Illus 86). They were typically 1.5–3m in length and 450–600mm in internal width. Irrespective of the material used for the retorts, the retort mouths, consisting of a hinged or clamped door and a connection for the ascension pipe, were made of cast iron. These were attached to the retort by means of a bolted flange or socket and spigot joint, with the joint sealed with a mixture of fireclay and other materials. The retort mouths, being located outside the furnace, had a

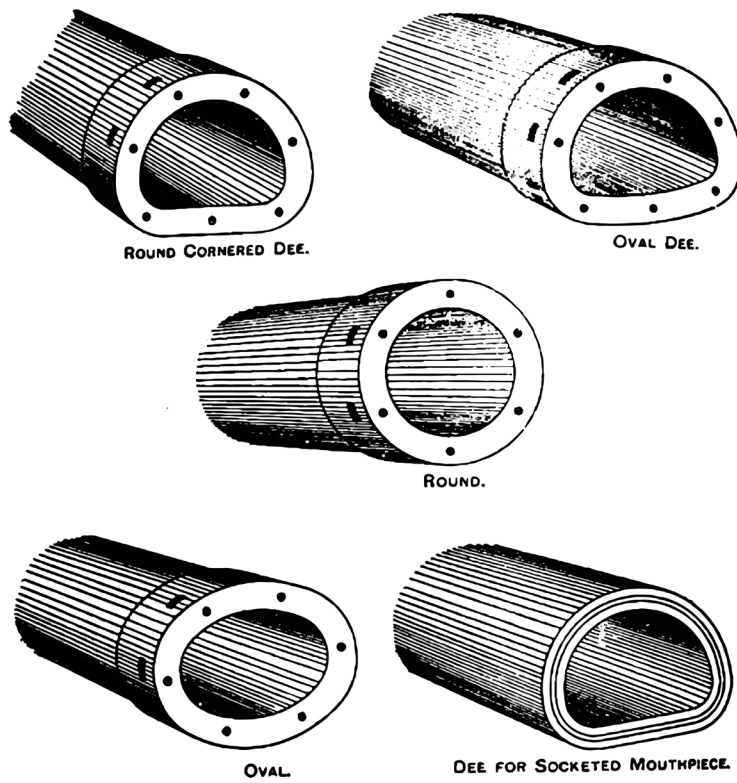

Illus 86 Examples of ceramic retorts (after Hornby 1911)



Illus 87 Ceramic retorts at the abandoned gasworks site at Shaw Lodge Mill, Halifax

Ceramic retort

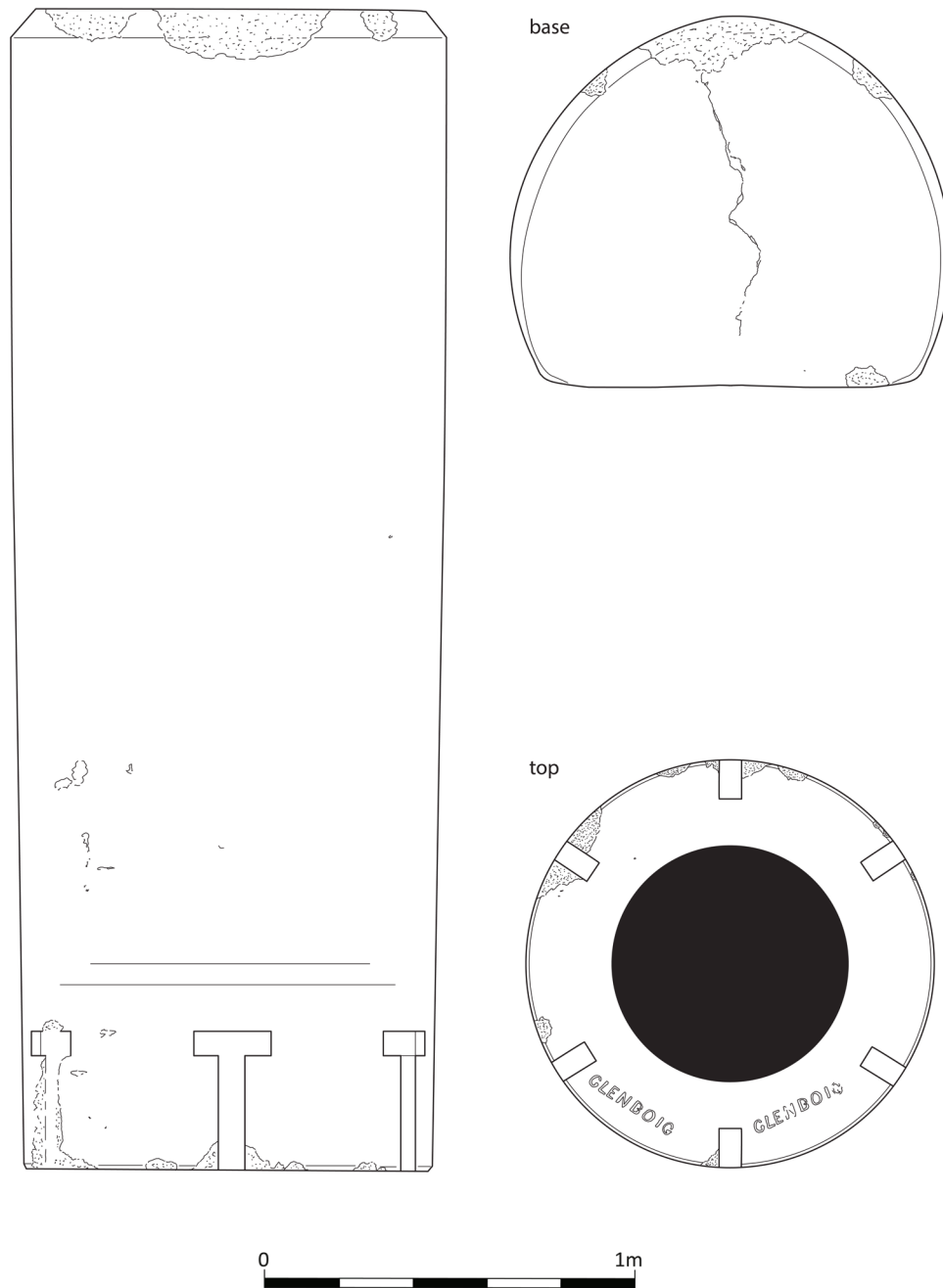

Illus 88 Intact fireclay retort

much longer life than the retorts, and were reused many times.

Where bolts were used to attach the retorts to the mouths, the ends (which were inside the furnace) experienced deterioration due to the high temperatures and so usually had captive nuts or T-shaped bolt heads to ensure they did

not turn when the nuts on the other end were being undone (see 9.8.4 'Internal furnishings associated with gas production' below). When coal gasification plants were demolished, the metal components, including retort mouths, were salvaged for scrap. However, ceramic retorts could not be recycled, particularly as they would

have been contaminated with waste products. In most cases, they would have been broken up and buried. Illus 87 shows a site at Shaw Lodge Mill, Halifax in West Yorkshire where the retorts have simply been left in situ.

9.3.3 The New Street retort

The ceramic retort recovered from the New Street Gasworks is an unusually intact example (Illus 65 & 88). It is D-shaped in section, 580mm wide and 1.57m long externally, with a wall thickness of between 60 and 70mm. These are dimensions typical for horizontal retorts in use from the 1820s until the end of the coal gasification era, although its length is perhaps shorter than the average for a late-19th-century example from a large urban gasworks. The flange at the open end is circular, whereas it was more common for D-shaped retorts to have D-shaped flanges (as shown in Illus 86). It has six T-shaped slots cast into the open end, suggesting that bolts with T-shaped heads were used to attach the retort mouth.

The retort bears the name of the manufacturer, Glenboig (Illus 89). The Glenboig Union Fireclay Company, based in the village of that name east of Glasgow, was a major manufacturer of refractory products from the 1830s. An 1886 press advertisement describes them as manufacturers of ‘Gas retorts of unequalled quality, of every shape and size, with the best settings’ (Scottish Brick History website: Glenboig). The flange is imprinted with the figure ‘5’ which may relate to a size or pattern number.

A brochure commemorating the expansion of Granton Gasworks in 1926 records that mechanical stokers were installed at New Street in 1896 (Edinburgh Corporation 1926). The introduction of this equipment would have necessitated significant alteration to the retort house, including almost certainly the replacement of the retort mouths with ones designed for use with mechanical stokers. It is likely that the excavated retort was part of this final phase of the development and originally installed between 1896 and the Gasworks’ closure.



Illus 89 Flange of retort stamped ‘GLENBOIG’

9.4 The bricks and tiles

George R Haggarty

9.4.1 The bricks

A representative sample of bricks and tiles from the New Street Gasworks was collected for further study. Eighteen of the marked examples are impressed either 'GLENBOIG', 'HURLL' or 'HURLL GLASGOW'. The history of these intertwined brickworks is complex and not easy to untangle. James Dunnachie moved to Glenboig and soon became manager of an existing small fireclay company. In 1865 he formed the Glenboig Fire-clay Company with John Hurlll and John Young, themselves pioneer firebrick manufacturers, and when the partnership folded in 1872, Dunnachie built the Star-Works immediately adjacent and in competition with them. Glenboig specialised in the production of refractory ceramic goods, including furnace lining, bricks, etc, for the iron and steel industry. Subsequent expansion meant the company acquired and went on to operate several other works, including the Cumbernauld Fireclay Works & Mine (*c* 1882), Gartcosh Works (1890), Castlecary Fireclay Co Ltd (*c* 1919), Faskine & Palacerigg Bricks & Coal Ltd (*c* 1919), George Turnbull & Co Ltd, and the Bonnymuir and Dykehead Works (*c* 1919). The Glenboig Union Fireclay Co Ltd was purchased by General Refractories Ltd of Sheffield in 1936. The 'Old Works' in Glenboig closed in 1958 and were demolished by 1965.

The partnership of P & M Hurlll was established in 1887 working a mine and brickworks in Drumchapel, Glasgow during the late 19th century. They also produced firebricks and chimney pots in a pale creamy buff colour, using clay from the Glenboig seam in Lanarkshire. This was mined heavily and continuously until it was worked out, sometime in the 1970s. Over time there were around 50 other firms producing chimney cans, with the last survivor being P & M Hurlll. In 1908 Mark Hurlll also leased the Birkhill clay mine with its high-quality fireclay deposits from Hamilton Estates. Situated at Manual Junction near Bo'ness, this clay had been exploited since the 18th century. Hurlll is known to have used different types of clay, with the locally mined Glenboig material being used for his regular firebricks. The famous Klinit clay, which was high

in alumina and which came from his Birkhill mine, was sold for use in industries requiring extra-high temperatures. Hurlll's Dourie bricks were made using a mixture of poorer-quality Ayrshire clay and local fireclay to provide a cheaper, poorer-quality product for less demanding applications. They also made 'Feather' bricks, which were exceptionally light for their size. It is thought that sawdust was mixed with the clay and burned out during the firing process. P & M Hurlll's two Glenboig works, 'Garliston' and 'Garnqueen', sat either side of the Glasgow to Perth railway and, with the rest of the business, went into liquidation in July 1980.

A single brick marked 'ATLAS' and five marked 'ETNA' also derive from complicated interrelated brickworks. In 1797 an area of land called Harestanes, part of the Hopetoun Estate, was sold to a William Davidson who changed its name to Bathville, and coalmining began there. Later, a John Watson of Glasgow bought the Bathville site for about £10,500 and constructed brickworks using fireclay which was being mined along with the coal. Although Watson's company became one of Lanarkshire's largest coalmasters, financial problems in 1874 forced it to sell the Bathville brickworks to James Wood from Paisley. Watson's brickworks then reopened as Robertson & Love's Pipeworks. Robertson, Love and Co were in operation at Bathville as brick and tile makers from at least 1882 (Scottish Brick History website: Bathville). In 1893–4, James and William Wood formed James Wood Ltd, to take over the coal interests together with the Etna and Atlas Brickworks (Bathville Brickworks). In 1895 they also had financial problems, which caused their estates to be sequestered. However, with new capital, they joined with Daniel Robertson, a firebrick manufacturer at Bathgate, to incorporate a new Scottish joint stock company, Robertson, Love and Co Ltd. By 1898 Robertson & Love's Pipe Works had been joined by Bathville. In 1916 Robertson, Love and Co Ltd was liquidated, but its firebricks manufacture continued under the United Collieries Ltd banner.

Four firebricks were recovered stamped 'BANKPARK'. These were produced at John Grieve Bank Park Firebrick works, which lay just north of Tranent and which was in production from the 1860s until the 1890s. Towards the end of this period, the name seen on bricks changed from John Grieve to J & C Grieve.

There are a few single marked bricks, including one stepped corbel-shaped example marked 'PERCETON KILMARNOCK', produced by J & M Craig at their Hillhead and Perceton Fire Clay Works and Longpark Pottery, Kilmarnock. The Craigs were manufacturers of fire and enamelled bricks, sewerage pipes and all kinds of sanitary and plumbers' earthenware. Another brick is marked 'ARNISTON 1868', which was produced by the Arniston Coal, Lime & Brick Works in Gorebridge, Midlothian. First noted in 1867 as John Christie, Arniston and Vogrie Works, Gorebridge, two years later, in 1869, a Robert Clark was managing it. The Arniston Coal Co, Edinburgh was registered in 1874.

A single brick marked 'Scottish Terracotta Co' was produced by the short-lived (1895–1903) Lee Terracotta and Scottish Terracotta & Metallic Brick and Tile Works, Braidwood, Carluke, South Lanarkshire. Mark Hurll transported raw materials from Carluke and the Lee works were erected by John Ferguson and John Agnew, who also operated the Omoa Fireclay Co. A single brick marked 'MUIR' was produced by the Barbauchlaw Brickworks, Armadale, West Lothian, which was in operation from *c* 1893 to 1971 and was originally owned by Robert Muir and Company. A single brick impressed 'WHITEHILL' was produced at the Whitehill brickworks in Lasswade. It was founded in 1869 by Archibald Hood. It was taken over by The Lothian Coal Company, whose directors included Archibald Hood, Colliery Owner, Managing Director and President of the Mining Association of Great Britain.

9.4.2 The tile

One of two white glazed tiles is marked 'Robert Brown & Son Paisley', which was made at the Robert Brown & Son, Ferguslie Fireclay Works. Acquiring the property of Ferguslie in 1850, Robert Brown founded the Ferguslie Fireclay Works and this originally produced fireclay linings for furnaces, garden ornaments and statuary for gardens. By 1876 the business had expanded into the manufacture of white sanitary earthenware, wall tiles and bricks. Brown's Brickworks remained a significant manufacturer and employer until the mid-1970s.

9.5 The ceramics

George R Haggarty

9.5.1 Introduction

The ceramic assemblage from the New Street Gasworks represents very mixed examples of pottery types spanning the late 12th to the early 20th century. Small quantities of residual medieval and post-medieval fabric attest to the former affluence of the area, particularly during the 17th and 18th centuries, from which sherds of Chinese porcelain, German stoneware, Dutch tin-glazed tiles and Italian vessels are recognised. The bulk of the assemblage comprises locally produced 19th- and early-20th-century stoneware bottles, as well as examples of encaustic tiles, produced in factories across Britain, that provide a glimpse of the former appearance of the more public areas of the Gasworks.

9.5.2 Medieval and post-medieval ceramics

The excavation produced a few, mostly abraded, late 12th/13th-century medieval body sherds, the majority of which derive from contexts (P0004) and (P0005) (Illus 90). As well as Scottish White Gritty Ware, the fabric of some of these sherds is consistent with examples imported from Yorkshire. Work carried out on other Scottish burghs suggests that Yorkshire was the source of much high medieval pottery imported into the larger Scottish east coast burghs during the late 12th and 13th centuries. Apart from a few unstratified sherds of 15th- or 16th-century date (SF18), including a thick jug sherd (SF12, Test Pit 1/A (north)) and four probable 16th-century sherds (SF41) from Context (K0316) (Illus 91), there appears to be a late-medieval hiatus until the 17th century, when sherds of the typical Scottish Post-Medieval Oxidised Ware (SPMOW) and Scottish Post-Medieval Reduced Ware (SPMRW) industries become common (eg SF41, (K0316); SF10, Test Pit 7/C; SF11, Test Pit 6/A; SF15, Test Pit 6/B (north); Illus 92). These wares have a wide distribution and date range, and examples recovered in the Edinburgh area and their sources have been discussed and summarised at length (Haggarty et al 2011; Haggarty & Hughes 2013; Haggarty & Lawson 2013b). There are a few abraded 18th-century sherds, generally in 19th-century contexts, except possibly (C0289) and (J0121).



Illus 90 Late 12th/13th-century medieval body sherds, (P0004) and (P0005)



Illus 91 Probable 16th-century sherds, SF41, (K0316)

9.5.3 Imports

Identifiable imports are rare but include a Ch'ien Lung (*c* 1760–70) Chinese Export teapot cover from Area H, Layer 008, which retains part of a flower knob and traces of red and black painting (Illus 92 & 93). Sherds of Chinese porcelain occur frequently in Scottish 18th- and 19th-century archaeological contexts. By the second quarter of the 18th century, Chinese exported porcelain was pouring into Europe in increasing quantities and prices were falling, making it available to the middle classes with the continued expansion of tea drinking. Tea had been introduced into Britain in the second half of the 17th century and rapidly became extremely popular. By 1687 the East India Company could place an order for 20,000 pounds of tea and by 1750 it was shipping over 2.5 million pounds of the product, reaching 20 million pounds by 1800. A logical extension of this trade was the importation of ceramic vessels for tea drinking. By the 1720s, in excess of 2 million pieces of porcelain were being imported into England each year.

A hammer-head rim sherd from a north German Wesser dish or bowl (SF7, Test Pit 5/B (north)) was also among the assemblage (Illus 94). Its upper surface has been covered in a white slip under the usual decoration of trailed bands of brown slip below a lead glaze. Highly decorated examples of this type of dish/bowl generally date from 1580 to 1630 in places such as Amsterdam and almost certainly were imported into Edinburgh through the port of Leith.

Four German stoneware sherds (not illustrated) with a thick, dark salt-glazed tiger-skin glaze, three of which (SF3, SF5 and SF11 from Test Pits 4/A, 5/A and 6/A) may be from the same small 17th-century Frechen bottle, were discovered within the test pits in the northern Gasworks site. One of these sherds, (SF11), derives from a moulded Westerwald-type biconic jug decorated with light and dark cobalt-blue bands (Illus 95). Cobalt decoration was introduced at Raeren by the potter Jan Eames in 1582, and from about 1590 some of the Raeren potters moved to Westerwald, where they produced similar wares that are difficult to tell apart and are therefore referred to as Westerwald type.

A tin-glazed plate sherd decorated with a brown painted Chinese porcelain-inspired rim (SF3) came from Test Pit 5/A (Illus 92 & 96). It has been

decorated with blue hatched flowers and leaves. The fabric is suggestive of production at a Glasgow Delftfield pottery. Similar tin-glazed fabrics were produced during experiments by James Watt in the third quarter of the 18th century (Haggarty & Grey 2013).

Italian wares are also represented from the northern area of excavation. These include a small redware flake from a 17th-century Italian marbled vessel (SF6 from Test Pit 2/A; not illustrated). This form of pottery has been noted among assemblages across Scotland and represents the fourth example from the Canongate (Haggarty & Hall forthcoming).

9.5.4 Later industrial-produced ceramics

The majority of the assemblage from the New Street Gasworks dates from the 19th century and is made up of common types of wares, including a few of the typical Prestonpans Rockingham glazed teapots (eg Bamboo and 'Duchess' styles), locally produced Portobello stonewares (Illus 97), and whitewares produced at a range of Victorian Scottish potteries. Very few of these late sherds are of significance, except for two transfer-printed plate sherds (SF93.2 and SF93.3) from Context (N0105); one has on its upper surface 'The British Public House Company Limited' (Illus 98) and verso a blue backstamp 'Genuine Ironstone China E. F. Bodley & Son Longport'. Edward F Bodley and Sons of the New Bridge pottery in Longton, Staffordshire were in production between 1883 and 1898. The second sherd of note has a transfer-printed vignette containing the letters [- - - DONIAN HOTEL / - - INBURGH]. This plate was almost certainly produced for the Caledonian Hotel which opened in 1903 and operates still at the west end of Princes Street, Edinburgh.

From Context (K1000), there is a moulded bisque porcelain figure of a (Russian?) boy (SF14), with a brown fur hat, green baggy trousers, yellow scarf and brown clogs (Illus 99). This figure almost certainly derives from one of many secondary 19th-century German ceramic factories and is likely to be associated with a moulded flower sherd (SF80.1) from Context (N0085). This sherd has on its verso printed '2264 GERM—', almost certainly a pattern number and part of GERMANY, which suggests a late Victorian date just prior to 1890. Due to the

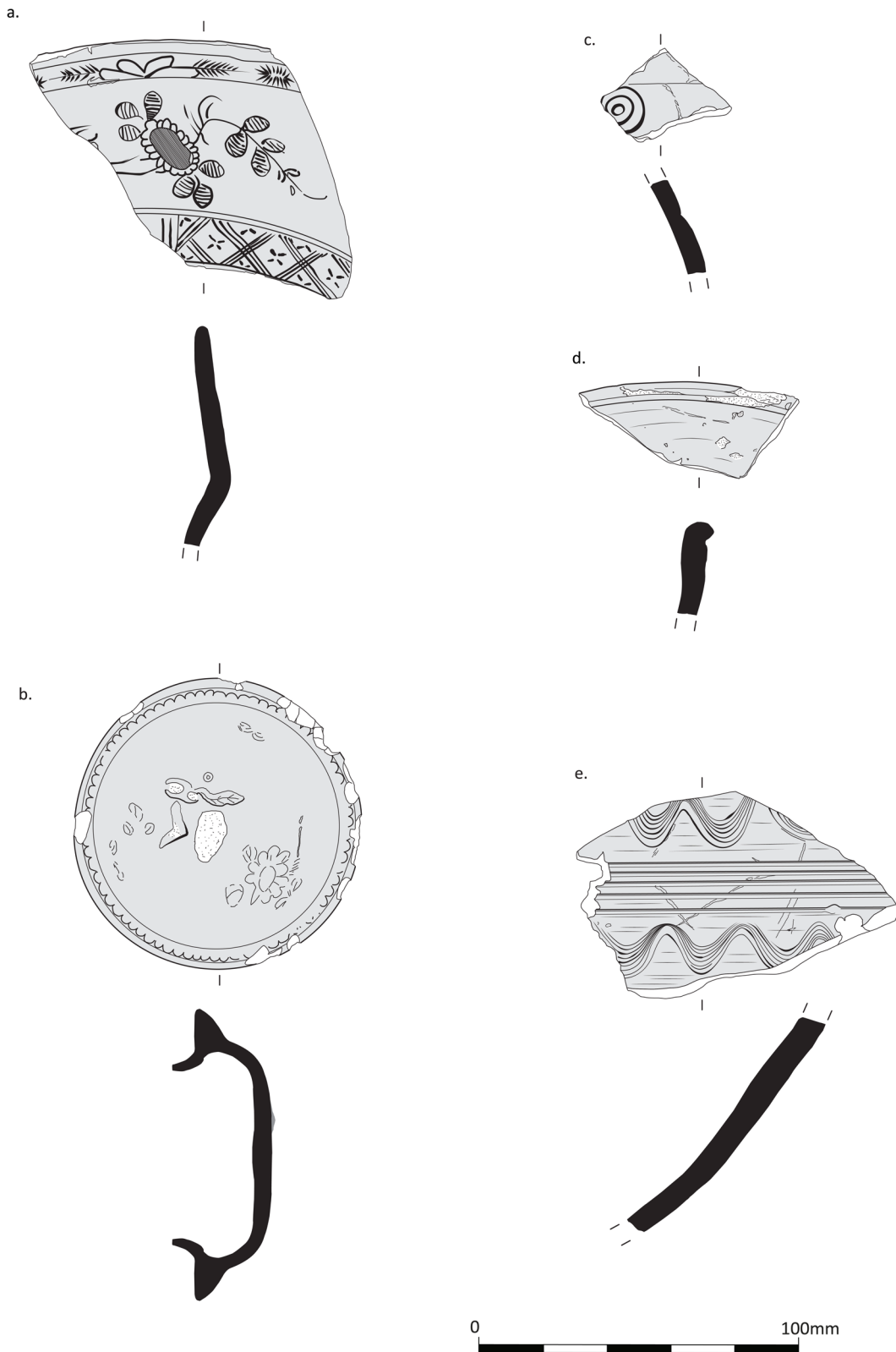

Illus 92 Various medieval and post-medieval ceramics: (a) tin-glazed earthenware, TP5/A; (b) imported Ch'ien Lung teapot cover, Layer 008, Area H; (c) decorated SPMRW sherd, SF10, TP7/C; (d) SPMOW platter rim, SF11, TP6/A; (e) decorated SPMRW sherd, SF15, TP6/B



Illus 93 Imported Ch'ien Lung teapot cover, Layer 008, Area H



Illus 94 Hammer-head rim sherd from Wesser dish or bowl, SF7, TP5/B (north)



Illus 95 German stoneware sherd from a moulded Westerwald-type biconic jug, SF11, TP6/A



Illus 96 Tin-glazed earthenware sherd with a painted Chinese porcelain-inspired rim, SF3, TP5/A



Illus 97 Selection of intact stoneware bottles from New Street Gasworks



Illus 98 Transfer-printed plate base sherd, SF93.2 (N0105)



Illus 99 Bisque porcelain figure of a boy, SF14 (K1000); H: 103.5mm

introduction of the McKinley Tariff Act in that year, subsequently it would almost certainly have been printed MADE IN GERMANY. From the same production area and of similar date, but far better decorated, are three sherds from a small porcelain coffee can (Context P0003; TP2) with a green background and a band of painted polychrome flowers with traces of gilding (Illus 100); the verso surface has a simple pattern and [252] black backstamp.

A 17th-century German Frechen stoneware body sherd (SF102.1) from a small bottle covered in a thick iron wash under a salt glaze, along with traces of a typical moulded beard, came from unstratified soils. Also of 17th-century date are three small sooted redware body sherds from Context (P0003) which are likely to be Low Countries imports.

9.5.5 Encaustic tiles

Encaustic was the term adopted in the 19th century to describe medieval floor tiles, usually produced in red or brown clay, whose decoration was indented with lighter coloured clay, a term now used to describe all inlaid tiles. Herbert Minton is thought to have turned his attention to the production of



Illus 100 Small porcelain coffee can, (P0003); H: 65.4mm



Illus 101 Fragment of a Minton encaustic tile, SF6 (B0001)

encaustic tiles in 1828 but it was a Samuel Wright, a zaffer (raw cobalt ore) merchant of Shelton in Staffordshire, who took out a patent in 1830 (Beulah 1990). In 1836 Minton agreed to pay Wright a 10% royalty and at some stage he began

to use brass moulds instead of the plaster examples used by Wright. This gave Minton's tiles sharper edges and, after experimentation with various clays, by 1835–40 he had started to fulfil orders.

There are a few interesting tile sherds, including



Illus 102 Conjoining sherds of a Craven Dunnill & Co Ltd encaustic tile, SF6 (B0001)



Illus 103 Fragment of a moulded Craven Dunnill & Co Ltd fireplace tile, SF32 (unstratified)

one of note from Context (B0001), which consists of approximately half of an encaustic tile (SF6) pierced on the verso surface with round holes in three lines of five, along with 'PATENT / STOKE UPON TRENT' impressed in large letters (Illus 101). This

is a part of a stamp that would have read 'MINTON & Co / PATENT / STOKE UPON TRENT'.

Also from Context (B0001) are two conjoining sherds (SF6) from a Craven Dunnill & Co Ltd encaustic tan-red-tan coloured sandwich tile (Illus



Illus 104 Fragment of a late-19th-century Dutch tin-glazed earthenware tile, SF24 (K0000)

102). These were produced by pressing a thin layer of good-quality clay into the mould, adding a thicker layer of poorer-quality clay and finally another layer of good clay. This forms a laminated structure which helped prevent warping and added to the tile's strength. It is impressed verso '--- LL / TILE Co / PATENT /--- UPON TRENT'. The encaustic decoration, which is made up of black, white and tan, was produced at the Ironbridge, Jackfield works between 1880 and *c* 1910. Unstratified SF32 is a fragment from a thick moulded green-glazed fireplace tile with '- PATENT C D -' verso (Illus 103). This was also produced by Craven Dunnill & Co Ltd.

The earliest tile fragment from the site is SF24 (K0000), a corner fragment from a 7mm thick, late-19th-century Dutch tin-glazed earthenware wall tile, which copies a Low Countries 17th-century example (Illus 104). The tile has been printed in blue with secondary red and green painting and has a fleur-de-lis in its corner and part of an open pomegranate.

9.6 The clay tobacco pipes

Dennis Gallagher

9.6.1 Introduction

The pipes from New Waverley range from the early 17th century to the early 18th century, the first

century of the tobacco-smoking habit in Scotland. The habit of pipe smoking declined in Scotland in the early 18th century as snuff became the favoured means of consuming tobacco. Pipes became popular again in the early 19th century. There are no 19th-century pipes in the present assemblage despite the nearby presence of the major pipe factory of Thomas White in Jack's Close.

9.6.2 17th-century pipes

Early 17th-century bowls

William Banks (Illus 105)

The earliest pipe in the assemblage is a small bowl (C1) datable to *c* 1610–20. It has the castle basal stamp which identifies it as an Edinburgh product and is a product of William Banks, who is recorded as a pipemaker in Edinburgh in 1622 where he held a monopoly (Gallagher 1987a: 5–8). It is the earliest pipe that has been clearly identified as a Scottish product and as such is the earliest known Scottish tobacco pipe to be found in Scotland (two comparable Edinburgh products were recovered from excavations in Carrickfergus, Ireland: Davey & Norton 2013: 142). The pipe is made from a reduced grey fabric with dark gritty inclusions. There are also unmarked bowls from the period 1610–40 (A1–A7). Some may be early bowls of William Banks but



Illus 105 Clay tobacco pipes of William Banks, c 17th century (© Dennis Gallagher)

the lack of marks makes assignation to a particular maker difficult. The pipes are biconical forms similar to those excavated from a pre-1637 context at the Tron Kirk, Edinburgh (Gallagher 1987b; Haggarty & Lawson 2013a).

The assemblage contains a large number of later products of William Banks (A8–A30). The Banks pipes vary considerably in quality. Most pipes had mould-applied initials on the side of the base, as was usual on Scottish products in the 17th century. Many had a basal stamp based on the arms of the city, an indication of the maker's recognised position within the burgh. However, the highest-quality pipes were hand-burnished to give the clay a high polish (eg A8 and A9). Some of the pipes show evidence of the mould-imparted letters of the maker's marks on the side of the bowl having been recut, a sign of long use (A12, A30 and possibly A25).

Thomas Banks (Illus 106)

Thomas Banks was a son of William Banks. The small narrow-necked bowls marked TB (A31–A34)

are datable typologically to c 1660–80 and may be assigned to the period after his father's death, when he emerges as an independent maker.

William Young (Illus 106)

Young is first recorded as a pipemaker in 1653 in the Pleasance, Edinburgh, and he died in 1670. His pipes (A35–A40) are of a distinctly bulbous form. He used a basal stamp that is a detailed variant on the triple-towered arms of the burgh of Edinburgh. The examples in the present assemblage show signs of wear of the die, but A37 (US/56) still exhibits the fine detail of the masonry.

Patrick Crawford (Illus 107)

Pipes marked PC (A41–A55) are identified as the work of Patrick Crawford, recorded as a maker in Edinburgh 1671–96. He supplied pipes for the ill-fated expedition of the Scottish colony at Darien. Some of the bowls are generally dated typologically to c 1660–80 and are possibly early examples of his work. However, examples from Darien, found



Illus 106 Clay tobacco pipes of Thomas Banks and William Young, c 17th century (© Dennis Gallagher)

together with much larger bowls, demonstrate the possible longevity of such forms. Crawford pipes have a variety of basal stamp styles. These range from a castle with flanking letters, influenced by the marks of the Edinburgh hammermen (A48 and A53), to a simple three-letter form (A54).

Other Edinburgh pipes

While the above makers are well documented, others are less so and there is less certainty about identifying their products and assigning date ranges. The large bowls marked RS (A56) are much less frequent than those of Crawford, indicating a much



Illus 107 Clay tobacco pipes of Patrick Crawford, late 17th century (© Dennis Gallagher)

smaller scale of manufacture. There is a comparable large bowl with a fairly upright form, of late-17th/early 18th-century date, from Edinburgh Castle (Gallagher 1997: 179, no. A50) and more forward-leaning forms from Edinburgh Canongate backlands (Gallagher 2013: 25–6). The bowl (A57) marked A/M (or possibly AW) is an uncommon find. Davey (1997: 96–7) has suggested that a similar pipe from St Andrews was a product of William Arthur of Edinburgh. A further example was recovered from the Holyrood Parliament site (Gallagher 2010: 55 and 56, fig 1.33). The bowl marked A/A (A59) is an upright form similar to A56. The maker of the A/A bowl (A59), with crudely formed initials on the base, is tentatively identified as Alexander Aiken. Pipemakers named Aiken have been recorded both in Glasgow and Edinburgh but the present pipe may be a product of Alexander Aiken who was married in Edinburgh in 1680 (Paton 1902: 11).

Dutch-style pipes (Illus 108)

Dutch imports of pipes were common in Scotland during the first half of the 17th century; however, the interruption of trade during the wars with the Dutch Republic, particularly that of 1665–7, together with the imposition of an import duty on pipes in 1661, limited the number of Dutch pipes entering southern Scotland (*RPS* 1661/1/122). Most of the Dutch imports were of low quality, for example A76, a bowl with a moulded rose decoration, the moulded decoration not incurring an extra production cost. Variants of this design are found throughout Scotland. Davey (1992: 280–1),

in his survey of Dutch imports, identified over 50 examples of this design, and examples continue to be found in Scottish assemblages, for example Holyrood, Edinburgh (Gallagher 2010: 57 and fig 139, no. 107) and Stirling Castle (Gallagher 2015: 239, fig 14.24, nos 7–13). A more unusual pipe of Dutch origin is a stem fragment of a Jonah pipe (A79). The complete pipe would be in the form of Jonah being swallowed by the monster, the scales on the present fragment being part of the latter's body (Duco 1987: 92). There is a similar fragment from Scalloway Castle, Shetland (Davey 1992: 281). One stem fragment is decorated with two fleur-de-lis stamps (A77), a style of decoration commonly found among Dutch imports into Scotland, but in this case it is indicative of a higher quality of pipe, as extra work was required during production to apply the stamps.

English-style pipes (Illus 109)

The present assemblage included 11 spurred bowls of a mid-17th-century date (A82–A92), a form not associated with Edinburgh pipemakers. None are marked, so there is no direct indication of place of manufacture. The form is generally associated with English pipes, possibly Tyneside (cf Edwards 1988: 9, Type 5 dated to *c* 1645–60). They vary in the degree of finish, some with a high burnish being a better quality of pipe (A88). While it is possible that an Edinburgh maker produced an atypical form, pipes of high quality normally would carry a basal mark based on the city's arms, the sign of an accredited manufacturer. They occur in small



Illus 108 Dutch-style clay tobacco pipes (© Dennis Gallagher)



No A82



No A83



No A84



No A85



No A86



No A88



No A89



No A90



No A91



No A92



Illus 109 Spurred clay tobacco pipes (© Dennis Gallagher)



No C5



No C17



No C13



No C19



No C21



No C20



No C6

Illus 110 Clay tobacco pipes of 19th-century date (© Dennis Gallagher)

numbers in some Scottish assemblages and are likely to be imports rather than Scottish products. Some were found in Edinburgh on the site of the Scottish Parliament (Gallagher 2010: 55 and 58, fig 1.40).

The pipes date from the period 1640–60 and may be associated with the Cromwellian occupation of Edinburgh when Cromwell’s army was quartered in the Canongate from September 1650 until 1660. The port of Leith acted as a supply base for the English

army and provisions were shipped from Newcastle and King’s Lynn. An insight into the mechanisms of this supply chain was provided by the finding of Tyneside pipes from the excavation of an English warship known to be carrying supplies from Leith that was wrecked off Duart Castle, Mull, in 1653 (Martin 2017: 206). Another group of English-style pipes was found at Dunstaffnage Castle, also occupied by an English garrison during that period



Illus 111 Clay tobacco pipes of 19th-century date (© Dennis Gallagher)

(Gallagher 1996). These English-style pipes, whether made by Scottish makers or imported, may be taken as evidence of that occupation. The smoking habits of the English soldiers is well attested in the Scottish propaganda writings relating to the invasion, for example, at Castleton, Roxburgh, where it was said that they burned the church communion table and ‘lighted their tobacco pipes’ with the books of Session (Burn 1829: 177).

A stem fragment (B4) has the roller stamp of John Thompson of Gateshead, who is recorded as a pipemaker *c* 1663–90 (Edwards 1988: 56, fig 11, no. 6). Stems stamped with Tyneside marks are occasionally found in Edinburgh, eg Advocate’s Close (Gallagher 2017: 44–6).

9.6.3 19th-century pipes (Illus 110 & 111)

Pipes of 19th-century date were found only in the north of the excavated area and the most prominent maker in that assemblage was Thomas White, the principal pipe manufacturer in 19th-century Edinburgh. A pipe factory was established in Big Jack’s Close off the Canongate in 1810 by David Sinclair and it was purchased by White in 1815. This factory was situated to the south of the present site, outside the excavated area. White died in 1847 but the business continued under his name, as Thomas White & Co. It moved from the Big Jack’s Close premises *c* 1867 (Gallagher 1987c). White was renowned for the high quality of his products and he developed an extensive export trade, in particular to North America and Australasia. Many of his pipes carried his distinctive TW mark on the bowl as well as his name on the stem. Such was the reputation of this maker that his TW mark on a spurred bowl was later imitated by most Scottish pipemakers, although often in a thicker-walled fabric (Gallagher 1989). This creates problems for identification when only the bowl is present. Only six stem fragments were identifiable as Thomas White’s products (C25–C29) but 15 bowls had TW in an oval facing the smoker. It is probable that many, if not all, of the latter are also White’s products.

Other bowls are similar to the TW mark but with TD in an oval facing the smoker (C21–C23). These include a complete spurred pipe where the mark is badly impressed but the letters on the mould appear to have been changed from TW to TD (C21). The

TD pipe was a form popular in the North American market and is thought to have been the mark of Thomas Dormer of London (1748–70). Like the TW mark, it was subsequently widely copied by other makers (Walker 1983: 36–8). The production of TD pipes is indicative of the firm producing pipes aimed at the export market.

The other pipes whose makers can be identified are from much smaller workshops which sold only to the local market, some having learnt their trade from Thomas White. Four stem fragments are marked MACKENZIE/MCKENZIE (C30–C33), one of which has the partnership of Mackenzie & Begg. John Mackenzie had workshops at various locations in Edinburgh from 1862 to 1895. Various members of the Begg family had pipe workshops in Leith during the period 1867–89. This partnership with Begg has hitherto been unrecorded. Two of the pipes (C30–C31) are varieties of the cutty, a thick-walled short pipe popular in the second half of the 19th century. The Rifle Cutty (C31) reflects the popularity of the Rifle Volunteer movement, begun in 1859 as a government response after the Crimean War to the small number of trained soldiers in Britain compared to other European nations (Beckett 1982: 91).

Two stem fragments marked R.HALL (C35–C36) can be identified as products of Ralph Hall, a pipemaker at 1 West Norton Place, Edinburgh from 1868 to 1870. The stem fragment marked P.WILSON (C34) is a product of Peter Wilson; the workshop operating under that name was active in Leith from 1847 to 1902. Although Glasgow was the largest centre of pipemaking in Scotland in the second half of the 19th century, no Glasgow pipes were found, indicative that Edinburgh residents favoured local makers.

9.7 The copper alloy objects

Andrew Morrison

9.7.1 Overview

A small assemblage of copper alloy (283.0g) was recovered from the excavations and comprised 15 artefacts, which included: two coins, a finger ring, a servant’s bell pull crank fitting, a button, a nail, a lamp fitting, a buckle, a length of pipe, and segments of copper wire. The objects were mostly

corroded, necessitating the use of X-radiography to aid analysis. The coins were a 1913 penny of George V (SF38), and a likely Queen Victoria halfpenny dating between 1860 and 1875 (Area FA3, Layer B). The button, a simple four-holed copper alloy piece with concave centre and flat brim, is inscribed 'Marshall & Aitken Edinburgh' (N0105). Marshall & Aitken were woollen drapers, tailors, clothiers and military outfitters who operated out of the High Street and North Bridge area of Edinburgh and were in business between 1828 and the early decades of the 20th century (Scottish Post Office Directories – Towns, Edinburgh: 1828: 119; 1871–2: 140; 1901–02: 239).

An unstratified Victorian finger ring came from Area N, with a simple copper alloy shank, split on each end to form a forked shoulder, which supports a linear claw-set three-stone cluster, with one remaining moulded emerald green glass 'stone' (Illus 121). This ring, alongside the Marshall & Aitken button, provides insight into the dress accessories and clothing worn by male and female employees of the Gasworks.

A copper alloy or brass bell pull crank fitting (SF83) is part of a servant's bell, or door bell system: a wire leading from a bell pull is attached to a crank, which pivots on a central spindle that is anchored to

a wall or ceiling; as the crank turns, a wire attached to its other end actuates a bell. Servant's bell systems first came into use in British stately homes around the 1730s, and by the 1750s had become common in metropolitan areas. In the early decades of the 19th century, house bell technology was adopted by the middle classes, and by the 1870s was familiar to most homes (Madill 2013: 15–17). Electricity rendered the bell pull system obsolete by the 1890s (ibid: 27). It is possible that the bell pull relates to the office area of the post-1820s Gasworks.

A small oil lamp fitting was retrieved from Area FA2 (Illus 112 & 121). This fitting has a threaded base to screw into a globular oil reserve, a thumbwheel for controlling flame size, and a nozzle from which the flame was emitted. It is likely that a glass cover would have sat within the body's undulating, snake-like decorative edge, protecting and diffusing the light of the flame.

A buckle with attached canvas fabric was recovered from Area FA1. The form of the buckle, combined with the sprung pin and a secondary arching pin designed to lock a strap in place, suggests that the buckle was designed to cope with a fabric and strap that was under high tension.



Illus 112 Brass oil lamp fitting, Area FA2, Layer B

9.7.2 Catalogue of illustrated items

► **Finger ring.** Three-stone cluster, claw-set within a flat sexafoil mount. Plain copper alloy shank with centrally split shoulders. One of the edge settings contained a small, moulded emerald green glass 'stone', now dislodged; other two stones missing. Ring is complete but distorted. Ring: H: 21.6mm, W: 20mm, Th: 5.8mm; Stone: H: 3.9mm, Diam: 5.5mm, Area N, Unstratified. Illus 121.

► **Oil lamp fitting.** Flat, circular externally threaded base (Diam: 27.6mm, Thread pitch: 2mm, Thread depth: 6mm). Central, elongated slot in base for insertion of fabric wick, regulated by thumbwheel (Diam: 15.4mm) with a ridged edge, set on a thin circular-sectioned stalk. Stalk/thumbwheel projects from the light fitting's perforated body. Body/collar is covered with perforations, set in vertical rows of four holes each. Body fans out towards top, terminating in a decorative edge (H: 18.7mm). H: 47.8mm, W: 68.9mm, Th: 18.4mm. Area FA2, Layer B. Illus 112 & 121.

9.8 The iron objects

Andrew Morrison & Dawn McLaren

9.8.1 Introduction

The varied iron assemblage from the New Street Gasworks comprises 215 iron objects (57.6kg), dominated by fractured and heavily corroded structural fixtures and fittings, machine components, equipment and architectural elements relating to the industrial activity at the Gasworks complex. The most significant aspects of the assemblage are those that can be associated directly with the gas production processes and associated activities and include hand-forged tools used to feed and clear the retorts and furnaces, retort inspection boxes and decorative wrought ironwork which probably derives from the public areas of the Gasworks.

The condition of most of the iron objects is poor; many are damaged and incomplete, often displaying severe corrosion of the surfaces. After the closure of the Gasworks, the site was dismantled and levelled to make way for a new bus depot and all of the below-ground, brick-built rooms, furnaces and other features were filled in with demolition rubble, which inevitably contained various iron fittings, fixtures

and tools left behind after the abandonment of the complex. Many of these objects have seen further breakage and damage as the result of the levelling process.

Large quantities of the artefacts were retrieved from the later levelling deposits, meaning that it has not been possible, in most instances, to identify individual objects with particular buildings or phases of the Gasworks' use. The following report presents a summary of the assemblage, drawing attention to those components of the assemblage that can be directly related to the processes undertaken at the Gasworks, to the equipment and internal fittings of the buildings and to the people that worked at the site. The objects will be discussed by functional groups and individual catalogue entries will be presented for illustrated items only. More commonplace and generic components of the assemblage will not be discussed in detail. A full catalogue of all the ironwork is presented in the site archive alongside a detailed methodology.

9.8.2 Classifications

The iron assemblage has been separated into the following groupings: architectural ironwork; internal furnishings associated with gas production; gas production equipment; other equipment and tools; fittings; miscellaneous and unidentified.

9.8.3 Architectural ironwork

A very limited quantity of objects (Q=5) among the assemblage are recognised as architectural ironwork: a galvanised steel chimney stack (Illus 113); a cast iron roof finial (Illus 114); a galvanised steel capping brace for a pitched roof; a wrought iron decorative panel (Illus 115), perhaps from an exterior fence or stairwell balustrade (SF23); and a section of cast frame from a lattice window still retaining some of the glass panes (SF16). The paucity of exterior and interior architectural elements that survive strongly suggests that the buildings were stripped out and any potentially salvageable metalwork (eg fencing, roof vent covers and steel girders) were removed for reuse elsewhere.

All these items came from demolition and levelling deposits and it is not possible to relate them to a particular building. The window frame (SF16)

and vinework panel (SF23) were both recovered from demolition deposit (K0000), while the roof finial was recovered from Layer B in Area 1A, and the roof-ridge capping brace and chimney pot were both from Layer B from Area FA2.

The galvanised steel chimney pot was originally cylindrical in shape with a crown top, though it is now distorted as the result of dismantling and subsequent burial (Illus 113). It would have been one of numerous chimney stacks used to vent fumes from the building interior and, as part of its

design, has a hinged access hatch and three L-shaped brackets at its base for fixing to the chimney structure. Made of the same form of galvanised steel sheet is a roof-ridge capping brace which came from Layer B, Area FA2. These braces are simple metal sheets which would have been hammered into position to act as a bracing cap along the ridge of a pitched roof and are a type of exterior fixture still used on roofs today. Galvanisation refers to the process of applying a zinc coating to the surfaces of iron or steel to prevent rusting of the metal. The

a.

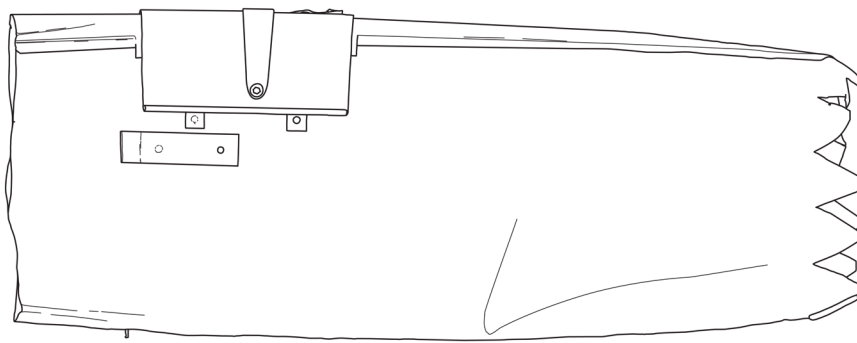

b.

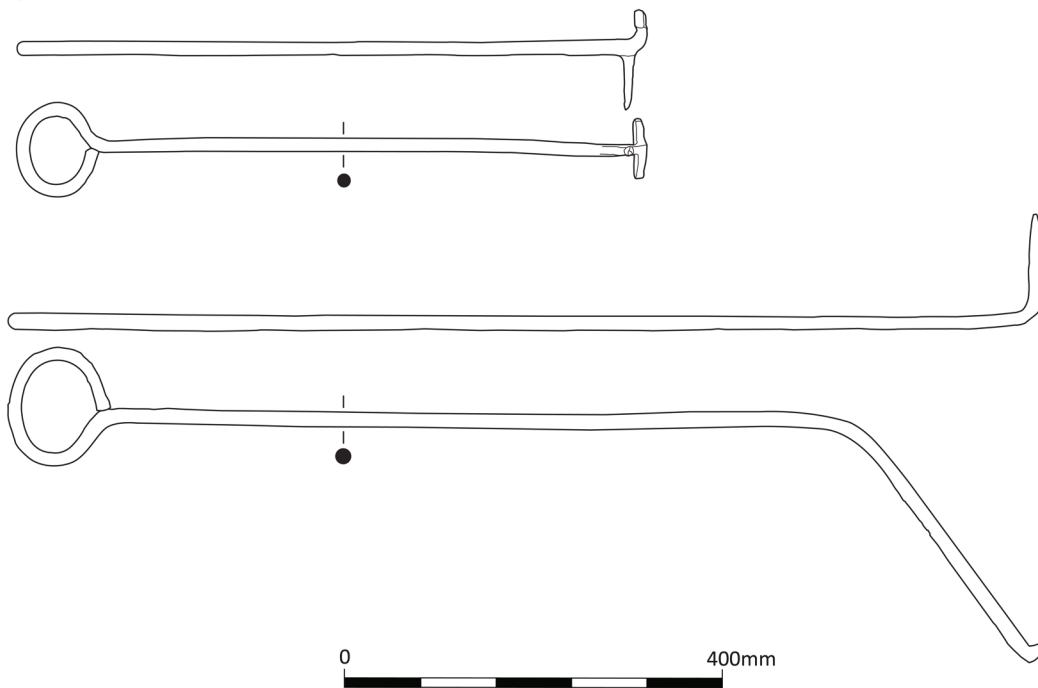

Illus 113 Iron artefacts: (a) galvanised chimney stack, FA2, Layer B; (b) long iron tools, Area 1A, Vault 9

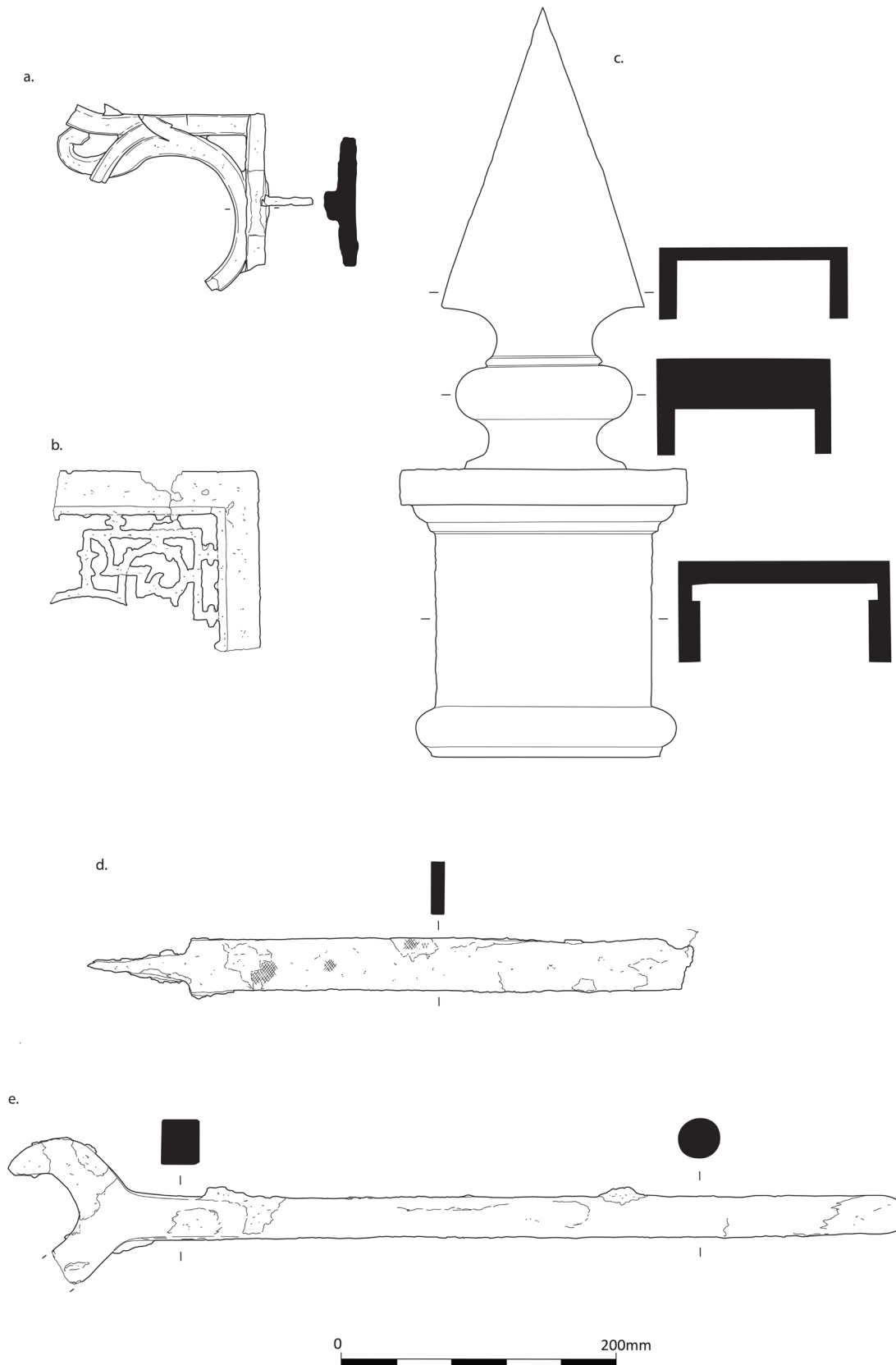

Illus 114 Architectural ironwork and iron tools: (a) decorative wall-mounted bracket, SF22 (K0000); (b) fretted vent cover, (K0000); (c) roof finial, Area 1A, Layer B; (d) large hand file, Area FA2, Layer B; (e) open-ended spanner, SF76 (N0085)



Illus 115 Wrought iron decorative gate or fence panel, SF23 (K0000)

corrosion of iron and steel fittings at New Street Gasworks was a documented problem; the exposed surfaces of metal fell victim to the corrosive fumes released during the gas production process, which led to the rapid deterioration of the metal fittings and fixtures. The process of galvanising steel was first patented in 1836–7 but did not see widespread use in Britain until around the 1850s (The Galvanizers Association), suggesting that these architectural fixtures were introduced in the later phases of the Gasworks' operations.

A robust cast iron roof finial (Illus 114) was recovered, with a box plinth body, collared neck and elongated arrowhead-shaped terminal that would have projected skywards from the gable end of one of the buildings, perhaps an office block. The rear of the finial is hollow, and there is a slot in the flat base into which a thin plate would have been inserted to affix it to a structure.

A small section of cast iron window frame (SF16) in a lattice pattern was recovered from a demolition deposit in Area K. This would likely have been part of an exterior window. Also present is a section of elaborate decorative wrought ironwork (Illus 115) in the form of a curling vine with stylised leaves. Likely

a section of railing, gate or stairwell balustrade, the vine stalk curls in an S-shape, branching into multiple sections, and terminating in four leaves and two tendrils. It may have been designed to fill a triangular-shaped or corner void, or it may have formed the tip of an arching design.

► **Galvanised steel chimney pot.** Cylindrical, now flattened, with pointed crown. Constructed of a single sheet, rolled, with a folded seam. Three L-shaped brackets towards the base of the stack, evenly spaced; side-hinged access hatch (H: 225mm) with pivoting latch mechanism and simple looped handle for inspection and cleaning. H: 910mm, Diam: 350mm, Th: 2.1mm. Area FA2, Layer B. Illus 113.

► **One-piece cast iron roof finial.** Moulded face and sides, hollow back and base. Top is in the shape of a plain arrowhead with rounded shoulder and short, wide tang above a convex collar and hourglass-shaped neck. Sits atop a box plinth with crown and foot mouldings and a plain panel and flat base. Slot in back of plinth box for finial to slide onto fixing. H: 545mm; W: 200mm; Box plinth H: 210mm. Area 1A, Layer B. Illus 114.

► **Wrought iron section of a gate, fence or panel.** Curling vine with stylised leaves. Circular-sectioned vine stalk, curving in an S-shape, and branching into different segments. The branches of the vine terminate in four leaves and two tendrils. The overall form of the ironwork and the points of breakage suggest that it may have been designed to fill a triangular, or corner, void. Traces of black paint remain. L: 380mm; W: 355mm; Th: 66.1mm; Vine Diam: 11.0–25.5mm. SF23. Area K, (K0000). Illus 115.

9.8.4 Internal furnishings associated with gas production

A total of 14 artefacts identified as internal furnishings associated with gas production were recovered. These include: three retort bolts, one complete retort furnace inspection box, two inspection box sliding doors, two inspection box fragments, five sheet metal fins, and one fretted vent cover. The sheet metal fins (SF35) come from a sandstone flagged surface (K0040), though it is likely they were deposited during demolition works.

The three retort bolts are T-shaped bolts with robust rectangular heads and square-sectioned shanks, threaded and circular in section along the lower half (Illus 116). These bolts were designed to fit into T-shaped slots moulded into the outer lip at the mouth end of a fireclay retort (see 9.3.3 ‘The New Street retort’ above; Illus 88). With the flat surface sitting flush in the slot, the T-shaped heads would lock the bolts in place, while the threaded shank protruded slightly beyond the lip of the retort, onto which a large hinged iron door and gas extraction assembly could be secured. The three bolts vary slightly in size, which could be an indication of different manufacturing batches or variations of fireclay retorts. In 1894, the retort-maker P Hurlll described over 60 different clay retort designs, each one of which would have required a different retort bolt (Cotterill 1980: 26). The retort bolts likely date from the 1830s or later, when the Edinburgh Company switched from iron to refractory ceramic retorts (ibid: 26).

The retort furnace inspection box is a cast iron hollow rectangular box equipped with a vertically sliding perforated door set within slots in the box’s flanged face; the door has a protruding tab with a chain attachment at one short end (Illus 117). The body of the box was designed to sit within the

brickwork structure of the retort furnace, with the tab and chain of the door orientated to the top of the box, showing that it was designed to be pulled upwards to open, to allow inspection of the furnace interior to judge the temperature of the retort (Francis 2010: 12). It may also have been used as a vent to partially increase air intake if needed when left fully opened. The most complete example was found in situ within the brickwork of the Phase 4 furnace in Area 1A, indicating a date of 1875 or later.

Five semi-circular sheet metal fins (SF35) were recovered from the surface of a flagstone floor (K0040), a Phase 2 construction dating from between 1818 and *c* 1845. The fins are approximately the same size, around 520mm in length and 535mm or less in height. On each fin, the short, straight side is folded at a right angle to create an anchor plate, with a combination of both square and circular holes for the fixing bolts. These fins are thought to be part of a funnel system related to the delivery or removal of oil shale and ash from the retorts, or coal/coke to the furnaces.

A further object of note is the corner fragment of a square or rectangular fretted iron vent cover (SF21a; Illus 118). Broken into two fragments, the decorative vent cover was recovered from the demolition fill within Area K. A photograph on display at the Biggar Gasworks Museum shows a similar iron vent cover in situ within a brickwork wall behind a stoker working the retort bank.

► **Retort bolt.** Large, robust, ‘T’-shaped bolt with offset rectangular head and square-sectioned shank. Threaded, circular end. Long edge of rectangular head sits flush with one side of the square-sectioned shank. Associated with retort (SF5). For securing hinged iron door assembly on to fireclay retort. *c* 1850–90s. H: 210mm; Head L: 60.7mm, W: 38.7mm, Th: 14.9mm; Shank Diam: 23.0mm. Area FA3, Layer B. Illus 116.

► **Retort furnace inspection box.** Iron rectangular box with sliding door/panel. Open face and open rear. Slight inward taper of sides from front to rear. Flanged face with slot for thin sliding door/panel. Door is flat rectangular sheet with tab along one short end, bent upwards for handle/hook/attachment. Hole in tab contains bent S-shaped wire which would have fastened to a chain. Nine circular

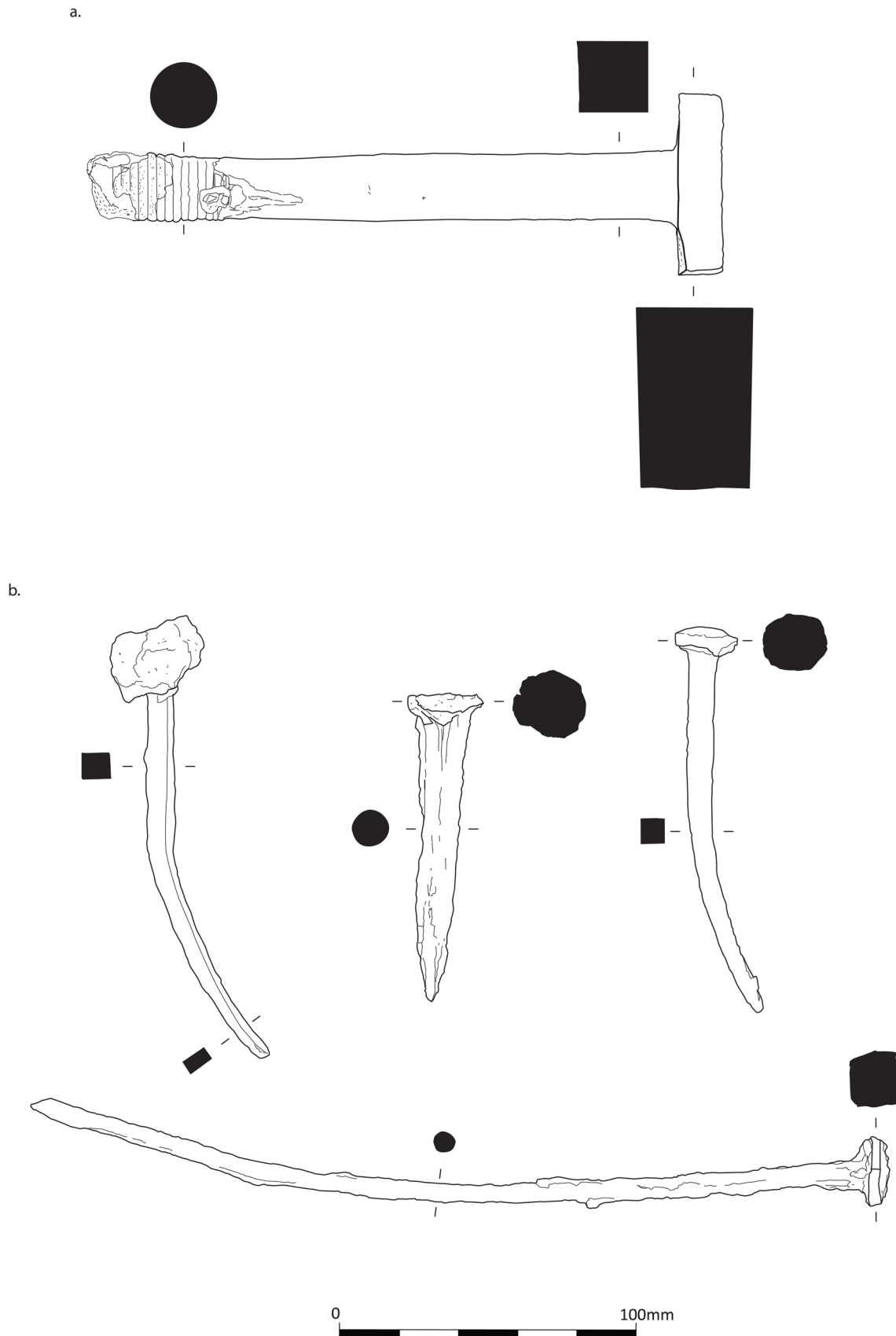

Illus 116 Iron fittings: (a) T-shaped bolt, Area FA3, Layer B; (b) iron nails, (J0121)



Illus 117 Iron retort inspection box in situ within furnace wall

perforations in a row down the centre of the door along the long axis. Box: L: 230mm; W: 140mm; H: 122.5mm. Area 1A, Layer B. Illus 117.

► **Fretted iron vent cover.** Incomplete and surviving in two joining fragments. Corner fragment with flat undecorated edge and raised internal lip, framing a central section showing an open-work square and vine motif. H: 129mm; W: 149mm; Th: 7.8mm. Area K, (K0000). Illus 114 & 118.

9.8.5 Equipment: tools associated with gas production

The artefacts discussed in this section have been identified as tools which can be directly related to

processes in the production of gas that required an element of human input or interaction – mainly in the delivery and removal of coal or coke, and the charging and unloading of the retorts.

In total, ten tools could be directly related to the gas production process. These comprise: five iron rod tools, a nail rake, a shovel blade and a spade blade, as well as a barrow wheel and axle-support bracket. Overall, the condition of the artefacts is very poor, with several objects surviving in a fragmented, highly corroded and extremely friable state.

The most significant of the tools associated with gas production recovered are five iron rod tools. These tools are made from a length of robust circular-sectioned iron rod, bent at one end into



Illus 118 Fretted vent cover, SF21a (K0000)

a simple looped handle with the other end either bent and shaped to form the tool head, or with a specialised head welded on (Illus 113). The five iron rod tools vary in terms of preservation, but two are complete and were discovered leaning against a brick side wall within Vault 9 in Area 1A. The shorter of these tools, measuring 0.6m in length, has an ovoid handle and straight shaft which is bent at 90° at the tip, from which a slightly curving bar-shaped rake head protrudes. A pointed spike extends from the head, forming a double-sided tool head. The longer of the tools measures 1.2m in length and has a head that is bent 90° and is cut to form a spike, perhaps used to stir the fuel during firing. The shaft of the tool is also bent, though this likely is caused by damage from use.

These simple elongated tools were ideal for manipulating materials that were worked at high temperatures, allowing the worker to keep at a safe distance from the heat source. Long iron rod rakes of up to 3.7m in length were used during the gas production process to draw the red-hot coke to the mouth of the retort where it was then either dropped into the coke vault below or wheeled away

in barrows (Anon 1866: 79–80). The length of the tools relates both to the depth of the retort and the heat of the material being worked. The short length of these tools, combined with their location within the vaults below the retort benches, suggests that they were most likely used for breaking up the coke once it had already been removed from the furnace, and would have been known as ‘clinking bats’ or ‘clinking spuds’ (ibid: 80; Illus 119).

A broken and corroded section of the head of a nail rake (FA2, Layer B) was recovered from a demolition deposit within Area FA2. Made up of a section of rectangular iron bar, it has three substantial protruding iron spikes, regularly spaced, and a hole at the broken end of the bar indicating the location of a fourth spike. It is likely that this nail rake would have been used to scrape out the bottom of the retorts, possibly after the coke had been removed.

The shovel blade (SF8) had an intact socket containing remnants of the wooden handle and a fixing peg still in place (Illus 120). A photograph (Illus 21) taken in the coal shed of the New Street Gasworks around the time of demolition shows the

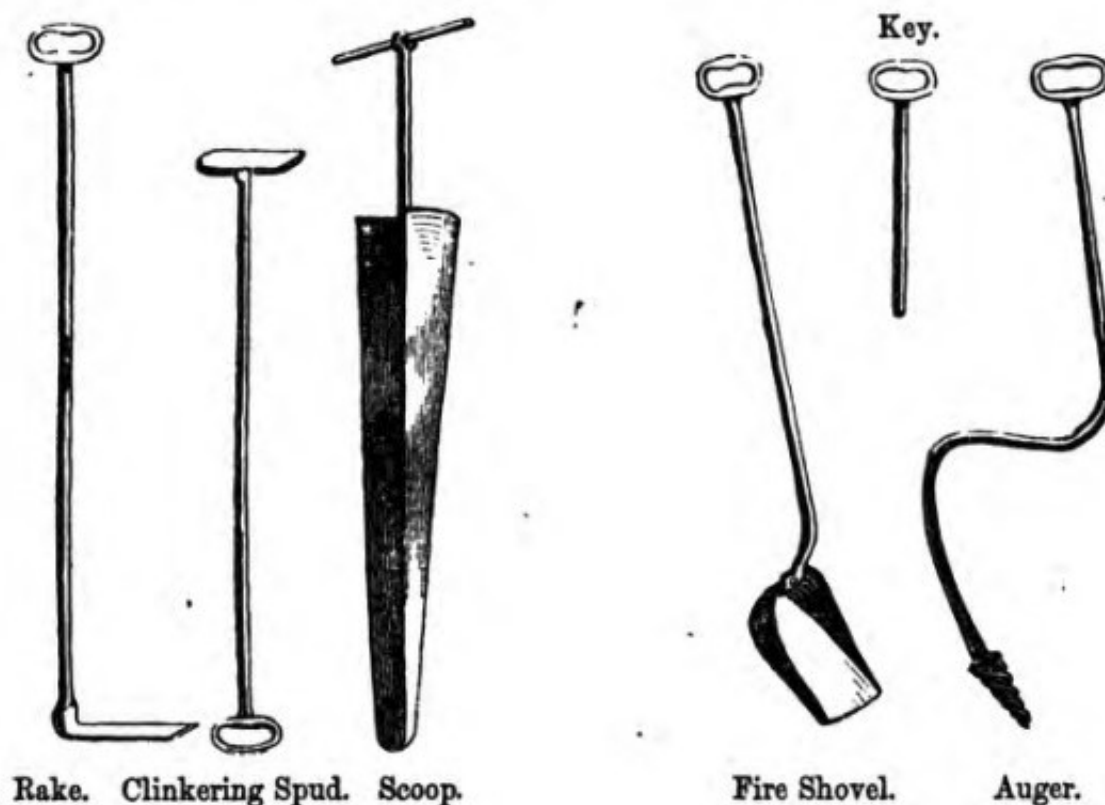

Illus 119 Contemporary images of similar elongated tools to those found at New Street (Anon 1866)

coal being shovelled from slat-built wooden carts onto a massive coal pile. A spade blade (SF36; not illustrated) has a flat, rectangular non-tapering blade that curves slightly towards the shoulder and, unlike the shovel blade, which is used principally to scoop material, the spade is designed to cut through material and probably saw use in another part of the Gasworks, such as the coal tar tanks or lime shed.

The barrow wheel and wheel assembly (SF36) recovered from floor surface (K0040) consists of a cast iron spoked wheel with projecting axle that spins within a pair of axle-support brackets, only one of which survives. Another D-shaped axle-support bracket (FA3, Layer B), identical in shape and size, was recovered from a demolition deposit in Area FA3. The wheeled barrows from which these components derive were used in the Gasworks to ferry fuel to the furnaces and to transport exhausted clinker and ash from them.

► **Rod tool.** Iron rod tool with bar and spike head and looped handle. Tool head is double sided, with

rod bent downwards 90° into a wide, flattened and slightly curving bar-shaped rake (H: 40.4mm; W: 63mm, Th: 10.5mm), with a pointed spike (H: 50mm; W: 10.5mm) projecting upwards from the top. Straight circular-sectioned shaft (Diam: 16mm), transitioning to an ovoid looped handle (W: 104.3mm). Tool is intact and undistorted. L: 665mm. Recovered from within Vault 9. Illus 113.

► **Rod tool.** Iron rod tool with spike head and looped handle. Head bent 90° and cut to form a spike (H: 117mm). Circular-sectioned shaft (Diam: 15.5mm) bent at approximately 45°; unclear if the bend is design or distortion. Shaft is long and straight, transitioning to an ovoid looped handle (W: 130mm). Tool is intact. L: 1,207mm. Recovered from within Vault 9. Illus 113.

9.8.6 Equipment: other

A wide range of other tools and equipment (Q=22) was recognised among the assemblage, including:



Illus 120 Shovel blade, SF8 (B0001)

barrel hoops, buckets, cans, canisters, chisels, files, clamps, keys, nippers, oil cans, punches, scrapers, shackles, spanners, straps and wrenches. These are general equipment typical of industrial works and are not unique to gasworks. Many are associated with the maintenance of the Gasworks apparatus and day-to-day building upkeep.

This group includes a hand punch, used to punch circular holes in sheet metal and usually used in conjunction with cast iron rivets. Tools like this could have been used to produce the rivet holes seen on the sheet metal fins noted above. An extremely large intact spanner (SF76) came from Context (N0085) and is likely associated with Phase 2 activity (*c* 1818–45). It was probably used to maintain the miles of piping that delivered gas from the retorts to the condensers, among other uses. More general tools include various different files from Area FA2, chisels, nippers for cutting steel wire, punches and a wrench that may have seen use in the smithy in the west of the site.

More portable tools, potentially carried for routine maintenance tasks around the Gasworks,

include a small double-ended alligator wrench, hand-forged with a short, rounded rectangular-sectioned handle (SF19), a possible scraper (SF33a) and a triangular head from a small hoe-like tool which came from Area FA1, Layer B. The function of this tool is unclear. Like the alligator wrench, it is a hand-forged object, probably made in the smithy on site and likely to be unique.

► **Large open-ended spanner.** Single head (W: 105.5mm) with fixed U-shaped jaws (Jaw profile: 56.1mm), one of which is broken. Long, circular-sectioned shaft (Diam: 29mm) transitioning to square section at head. L: 645mm. SF76, Area N, (N0085), likely associated with Phase 2 (*c* 1818–45). Illus 114.

► **Large hand file.** Rectangular section and straight sides. Damaged tip, with concretions and loss to corrosion. Appears to be a single-cut file. Tang is intact (L: 75.7mm). File: L: 365mm; W: 38mm; Th: 9.5mm. Area FA2, Layer B. Illus 114.

9.8.7 Fittings

The majority of the iron assemblage from the site (146 items; 68% of the assemblage) falls under the category of structural and internal fixtures of types which are commonplace at any 19th- and early-20th-century industrial building and are not considered to be unique to a gasworks setting. These include various nails (Illus 116), bolts, brackets, spacers, pipes and handles.

Among the more generic fixtures and fittings are components of hydraulic equipment and mechanisms. These include a large, robust possible cotter pin (Context FA3, Layer B) used to fasten two parts of a moving mechanism together, and a composite spacer made of eight separate movable parts (SF37) which was recovered from Context (K0040), undoubtedly a component of a hydraulic system. Various pipe fragments, pipe junctions and flanged pipe brackets were recognised among this group but it has not been possible to connect these with certainty to a particular stage of the Gasworks' processes; they could have been used to distribute the unfiltered gas from the hydraulic main to the condenser but equally could have facilitated the transport of water around the factory. At least two spoked hand wheels came from Layer B in Areas FA1 and H. Photographs of the compressor suite prior to demolition capture the configuration of the hydraulic equipment, including hand wheels, which would have been used to adjust the pressure and flow within the pipes by opening or closing valves within the pipes.

Also present is a substantially complete latch plate from Layer B, Area FA1 – a flat rectangular plate with a circular peg protruding from one end. This robust fixture is not consistent with the type of latched fitting used to secure the cast iron retort doors but could have served a similar function, perhaps on the furnace doors.

Alongside the more practical fixtures and fittings is a robust decorative wall-mounted bracket (SF22), which was recovered from unstratified material in Area K. It is a right-angled bracket with a lobed anchor plate and decorated bifurcated arm and may have functioned as a decorative shelf support.

► **Wall-mounted bracket.** Robust, decorative right-angled bracket with a dual-lobed anchor plate (W: 95.8mm), one ear projecting from each side of the vertical back bar. One hole in each of the lobes, set within a rectangular groove cast into the rear of the anchor plate. A square-shanked nail survives in situ within one of the anchor holes. A horizontal arm with a flat top (W: 21.8mm) projects from the vertical back bar (W: 30mm), bifurcating towards the tip, splitting downwards. Decorative curled ironwork loops from below the horizontal arm, snaking below in an S-shape to the vertical back bar. The lower extent of the horizontal arm and curved base of the vertical section appear broken, and would possibly have joined in a circular loop. H: 127mm; L: 150mm. SF22. Area K, (K0000). Illus 114.

9.8.8 Miscellaneous

Within any large assemblage of industrial ironwork there is a small number of individual components that cannot be closely identified due to their fragmentary condition or their unremarkable form. Within this assemblage various bars, box fragments, rings, loops, rods and sheet metal fragments could not be assigned to a particular function or date.

9.8.9 Discussion

It is clear that the majority of the Gasworks' iron fixtures and fittings, machine parts and tools had been stripped out for reuse or recycling prior to the demolition of the structures and what was left behind comprised broken, damaged or hard-to-reach items of limited further use. Only a few recognisable implements and fixtures survive to enable a snapshot of the workings of the factory.

The architectural elements, including the roof finial and vinework panel, are the only artefactual survivors to provide an indication of the overall external appearance of the Gasworks structures. An analysis of photographs of the New Street Gasworks did not show these components in situ, though most photographs were either taken from a distance or captured the Gasworks during its dismantling. Most likely dating to around the mid-19th century, the elaborate vinework panel and decorative roof finial were designed to be visible to the public, and may

have been part of the main office building, or of the street facade (Pearson 2016: 59), and they survive as reminders of the importance of image and style for the urban Victorian industrial complex.

The damaged condition of the recovered tools is perhaps not surprising, as they would have been subjected to high heat and high stress, and would have seen heavy, continual use, with frequent damage. The long rod-shaped retort tools were most likely manufactured on site at the Gasworks smithy and would have been quick and easy to produce, with the same simple loop handle and iron rod shaft fixed with a multitude of heads (Anon 1866: 80). Due to the probable high rate of turnover of these tools, it is likely that the two intact tools recovered from Vault 9 were among the last of the tools used prior to the Gasworks' decommissioning in the early 20th century. Surviving examples of the looped handle, iron rod tool type on display at the Biggar Gasworks Museum indicate that these tools were also used in the operation of the boilers, as well as in the cleaning out of the retort gas extraction tubes that led to the hydraulic main.

In general, the surface condition of the iron artefacts was poor, likely to be the result of corrosive gases that were documented in contemporary sources as a problem, and does not indicate the use of low-quality or inferior iron or steel. Steps to circumvent this corrosion were taken during the later years of the Gasworks, indicated by the installation of innovative galvanised steel fittings, such as the chimney stack, which would withstand the polluted air more effectively.

9.9 The lead objects

Andrew Morrison

9.9.1 Overview

The small assemblage of lead (Q=21, mass: >1,880g) is dominated by roofing nails and also includes pipes fragments, lead sheet, a rectangular open-topped box, molten spill and a possible wheel rim counterweight. The finds were in relatively good condition, with little corrosion present, apart from the open-topped rectangular box (SF2), which showed considerable loss to corrosion.

Roofing nails were the most numerous lead artefacts recovered (Q=13), representing almost

62% of the assemblage (Illus 121). The nails were retrieved from different areas but are likely all associated with the demolition of the buildings, making it impossible in most instances to assign individual objects to specific buildings of the Gasworks. The nails all have flat, circular heads with casting lines underneath, slightly tapering, trapezoidal-sectioned shanks and flat tips. They are all roughly the same size, with a head diameter around 19mm, an average length of 116mm, and shank dimensions between 4mm and 7mm in width. Most of the nails are curled in a C- or G-shape, or with a bend towards the tip, with damage to the head, suggesting distortion during removal. One of the roofing nails (FA2, Layer B) is preserved in situ within a fragment of roofing slate, inserted through the nail hole, and held in place by its circular head and curled shank. The lead roofing nails would have acted as 'bent pegs' (Hathaway 2012: 20), with the heads acting as stoppers to the slate nail holes rather than striking platforms, and the flexible shanks used to hook around the roof purlins.

Another find of note was a small possible wheel rim counterweight (Illus 121). An unstratified find from Area N, this possible counterweight is crescent-shaped, triangular in section, with a slightly concave edge tapering to a point at each end. The concave edge is thought to reflect the shape of the inside surface of a small wheel rim. This object would have served to balance a small wheel during rotation, possibly set against the movement of a piston.

Other finds include: a rectangular, open-topped sheet lead box (SF2), a triangular fragment of lead sheet (FA2, Layer B), a length of small-diameter lead pipe (SF20.2), a fragment of large-diameter lead pipe or vessel rim (SF72), and three fragments of molten lead spill (SF70). The rectangular, open-topped sheet lead box is made from a single lead sheet bent around to form the face, base and rear of box, with separate rectangular sheets forming the two sides.

9.9.2 Catalogue of illustrated objects

► **Possible rim counterweight.** Crescent-shaped, lightly distorted, with slightly concave edge tapering to points on each end. Roughly triangular in section. Edge shows indentation from contact with another circular surface, likely the inner rim of a small wheel.

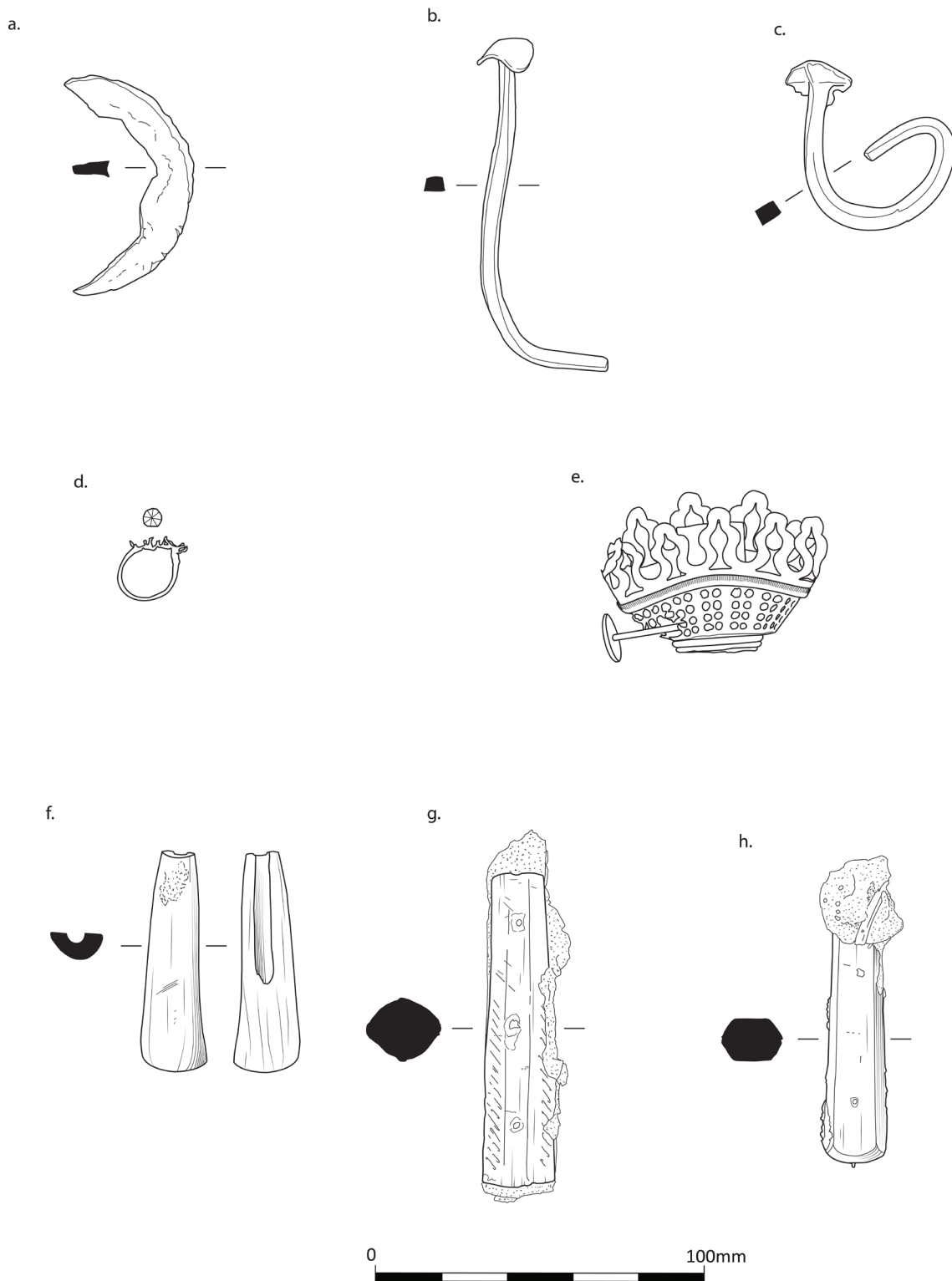

Illus 121 A selection of lead, copper alloy and worked bone artefacts: (a) possible rim counterweight, SF81.5 (Unstratified between (N0501) and (N0502)); (b) lead nail, Vault 9; (c) lead nail, Vault 9; (d) copper finger ring, Area N; (e) brass oil lamp component, Area FA2, Layer B; (f) bone handle, SF5, TP4/A (north); (g) bone knife handle, (P0004); (h) bone knife handle, SF79 (N0085)

Likely to balance a wheel by acting as a counterweight, possibly a wheel with a piston attached. Diam: 66.5mm, covering roughly 50% of a circle; Th: 4.5mm. Mass: 25.22g. SF81.5. Area N, unstratified between (N0501) and (N0502). Illus 121.

► **Nails.** Three roofing nails. One straightened, two curled in C- or G-shapes. Tips all flat, not distorted. Total Mass: 91.96g. Area 1A, Layer B, Vault 9.

1. Straight nail, with distorted round head. Slightly trapezoidal shank tapering to a flat tip. Head Diam: 15mm; Head Th: 1.7mm; Shank W: 4.5 × 6.9mm; L: 117mm (not illustrated).

2. Nail bent in G-shape. Head Diam: 20.1mm; Shank W: 6.1 × 6.8mm; L: 118mm. Illus 121.

3. Nail bent in C-shape. Head Diam: 17.6mm; Shank W: 6mm; L: 109mm. Illus 121.

9.10 The glass

Andrew Morrison

9.10.1 Introduction

An assemblage of glass (12kg) comprising approximately 130 artefacts, included: 19 intact

glass bottles, four of which had their closures in place, 70 sherds of bottle glass, 41 window glass sherds, 11 tableware sherds, various fragments associated with glass working, a patented wedge-shaped object and a glass marble.

9.10.2 Bottles

The glass assemblage is dominated by mid-19th- to early-20th-century bottles (Illus 122) and bottle glass, including wine, beer and spirit bottles, aerated water bottles, medicine bottles, and food storage bottles and containers, with some tableware and window glass also present. These finds are contemporary with the period between the mid-19th-century expansion of the Gasworks up to its eventual demolition in the early decades of the 20th century.

Typical of 19th- and early-20th-century urban glass assemblages, a similar range of bottle glass has been uncovered on nearby sites such as Advocate's Close (Wilmott 2017: 35) and Parliament House (Murdoch 2008). The glass is largely mass-produced, mould-formed glass, many examples of which bear the moulded markings from local businesses in the



Illus 122 Selection of intact 19th- and early-20th-century glass bottles

Canongate and Leith, as well as ones further afield. Green bottle glass such as this is common on most Scottish sites from around the early 18th century onwards (Murdoch 2008). While some of the bottle glass recovered may date to the earlier 18th century, its date of deposition could be much later, as bottles were refilled and reused over extended periods before breakage and discard (*ibid*). A few examples of unstratified late-18th- and early-19th-century bottle glass are recognised. The bottle glass from the north area of excavation ranged in colour from a forest green, to a light to dark olive green, with the window glass mostly showing a light greenish-yellow tinge. No intact bottles were recovered, though sherds representing all parts of the bottle were recovered.

Some of the more diagnostic bottle sherds include: an olive green base sherd with bulging heel and dome-shaped push-up, dating to the late 18th to early 19th century (SF5), and an 18th-century, light olive green neck and finish sherd with added rounded string rim (SF8).

A total of 19 intact bottles were retrieved, four of which have their closures in place, and some with remnants of liquid contents and residue still within. Of particular note are an intact 'William Younger and Company Ltd, Edinburgh' beer bottle (post-1921) with closure in place and liquid contents within (Unstratified); an intact spirit bottle from 'William Laird, Wine and Spirit Merchant, 88 Constitution St Leith', dated 1895–9 (Area 1+2, Layer B); a partial spirit bottle from 'Robert Liddle, Spirit Merchant, 186 Canongate, Edinburgh', dating from 1895–1904 (SF29); an intact soda bottle from 'G & C Moore aerated water manufacturers and bottlers, Glasgow', dating from the 1880s–1920s, with closure in place (Unstratified); an intact amber glass prescription bottle from 'Parke, Davis & Company Pharmaceuticals', from the 1870s to early 1900s (SF13); an intact late-19th- to early-20th-century bottle of 'Angier's Emulsion', with oily residue (Unstratified); a large, intact fruit jar from 'Cannington, Shaw & Company Ltd St Helens, Lancashire', dating from 1892–1913 (SF13); and an intact preserve jar from 'Samuel Hannah & Company, Rutherglen', dating from 1890–c 1912 (SF13).

Few glass finds were recovered from secure contexts, although those that were provide valuable

dating information. Among these are a diagnostic green bottle glass base and body sherds dating to the late 19th to early 20th century from (J0269), including a base fragment with 'A' and '1879' moulded on the base (SF30.2). An intact, clear blue aqua glass bottle with cork closure, as well as a possible ink well with burst lip finish, were both recovered from (N0085), associated with a stone wall, and both date from the mid-19th to early 20th century (SF80.2).

9.10.3 Table wares

Tableware fragments among the assemblage included joining sherds of light emerald green faceted glass, possibly representing a Victorian candle holder (SF29), and a fragment of a clear, press-moulded sunburst-patterned dish, dating from the late 19th to early 20th century (SF80.2).

9.10.4 Window glass

A small quantity of window glass (41 sherds) was recovered, comprising mostly clear, colourless sheet window glass, likely dating from around the mid-1800s to the early 1900s; sheet glass was introduced into Britain around 1830 and quickly overtook crown glass as the preferred method of manufacture (Murdoch 2008: 287). Some window glass shows a slight green tinge and may date to the 18th century or slightly earlier, including four sherds displaying possible edges (SF88) from (N0105). One sherd of clear green aqua coloured glass (SF6) from TP2/A also displays a potentially hand-finished edge and is also likely to be 18th century in date.

9.10.5 Other

Other glass finds include: a robust glass wedge, a cylindrical tube, a marble, as well as objects that suggest a possibility of a small amount of glass working taking place on site. The robust glass wedge (SF12) is a fragment of a larger, patented object of unknown function. Found unstratified in Area J, the clear, colourless moulded glass rises at an approximate 35° angle, with flat, frosted edges. The object may possess optical properties, though it is unknown if these would be intentional. The cylindrical tube (SF102.2) came from Area N and

may have been involved in the transport of gas during production.

A few of the glass objects recovered suggest the possibility of glass working in the vicinity of the site and are likely unrelated to the Gasworks. These include a large lump of clear molten glass, a lump of molten dark inky-blue glass, and a fragment of industrial ceramic with a greenish-clear molten glass coating. Finally, a fragment of industrial firebrick-type ceramic with a clear to greenish tinge molten glass coating was recovered from Layer B within Area FA3. The glass appears to have formed and flowed in layers over the surface of the ceramic,

which is roughly circular in section, sloping to a wedge shape at one end.

9.11 The industrial residues

Dawn McLaren

Various industrial residues were encountered during the excavations, particularly in and around Areas C and K, focused on the flues, furnaces and retorts. Small quantities of these residues, totalling 1,025g in weight, were collected as representative samples and have been retained as part of the site archive. Macroscopic examination has allowed these residues to be identified as unintended by-products



Illus 123 Corrosive vitrified residue build-up in the interior of working retort at Biggar Gasworks Museum

of the high-temperature processes involved in gas production. None of the waste is diagnostic of metalworking, despite the documented presence of a blacksmith's workshop within the Gasworks complex. A further 4,504g of waste, dominated by mixed fuel residues, were extracted from soil samples.

The majority of the residues consist of fractured, broken-up pieces of thin films of vitrified materials which had formed as sheet-like coatings on the interior surfaces of the flues and retorts. In the main, these appear to have formed as the result of high-temperature reactions between the fuel (coal and coke), the various corrosive gases released from the coal, ash, and the surfaces of the ceramic material of the structures (eg brick and refractory ceramic), which would have acted as a flux, as seen in metalworking furnaces.

A low-density, highly vesicular, non-magnetic film of vitrified material was noted on the interior surface of brick-built flue (C0032) and on the surrounding floor. This brittle and friable material is a light grey/mid-grey in colour, adhering in places to a red-brown ceramic (brick?) and yellow-brown stone. Amorphous chunky fragments of a low-density, sintered, ceramic and ash-rich residue came from the inner surface of flue (C0034). This has vertical lathe-like structures which appear to be slow-formed accumulations of granular heat-affected siliceous material, probably extruded from the bricks, and formed against a flat surface. Similar small fractured sherds of this heat-affected material were also recovered from contexts (F0032), (J0312) and (K0537). Fragments of a thin, flowed film of a dense vitrified material with vertical lathe-like impressions in relief were recovered from the interior of round-headed brick flue (C0035). Each fragment of this material was coated on one surface with an off-white powdery material, possibly lime or sulphur deposits.

Large, flat, fractured sheet fragments of a ferrous-rich material came from around the retorts in the area of (K0009). These residues could easily be mistaken for ironworking debris, particularly due to their silvery-grey colour, metallic-looking sheen and magnetic response. However, a similar film of waste was noted on the interior surfaces of a ceramic retort excavated at Salamander Place, Leith (McLaren forthcoming),

which derived from the Edinburgh and Leith Gas Company, and was observed inside the working retorts at Biggar Gasworks Museum (Illus 123). This material is likely to have accumulated over time, building up in layers on the interior of the retorts as the result of chemical reactions between impurities in the coal being heated, particularly naturally occurring iron-bearing clasts, the steel retort collars, the corrosive gases released from the coal, and siliceous material from the ceramic retort which would have acted as a flux, resulting in the viscous material becoming partially or fully molten.

9.12 The leather

Clare Thomas

9.12.1 Introduction

The leather assemblage comprises 37 items, all footwear of riveted construction apart from two squashed fragments of a ball.

9.12.2 Footwear

The footwear consists of 15 shoes or significant parts of shoes, 11 sole fragments and 10 small pieces of uppers (Illus 124). The soles and uppers were all joined by rivets. A few soles had been repaired and upper fragments were machine sewn to each other. Many upper fragments also displayed evidence for linings, lace-hole facings and heel stiffeners. A few soles were reinforced with iron plates. Ten uppers had lace holes for a central fastening. Sizes varied between a child's size 1 (continental 16½) and an adult 6 or 7 (continental 39–41). One upper has part of a manufacturer's stamp.

9.12.3 Construction

All the sole fragments and the uppers with lasting margins bear evidence for riveted construction, in the form of both rivets and rivet holes. The rivets used on boot 18 have a screw threading. Five sole fragments have hobnails (Catalogue nos 1, 17, 20, 26 and 27). Two heels have iron heel reinforcers; another sole fragment has an iron plate, and a further iron plate survives separately (Catalogue nos 16, 17, 20 and 27).

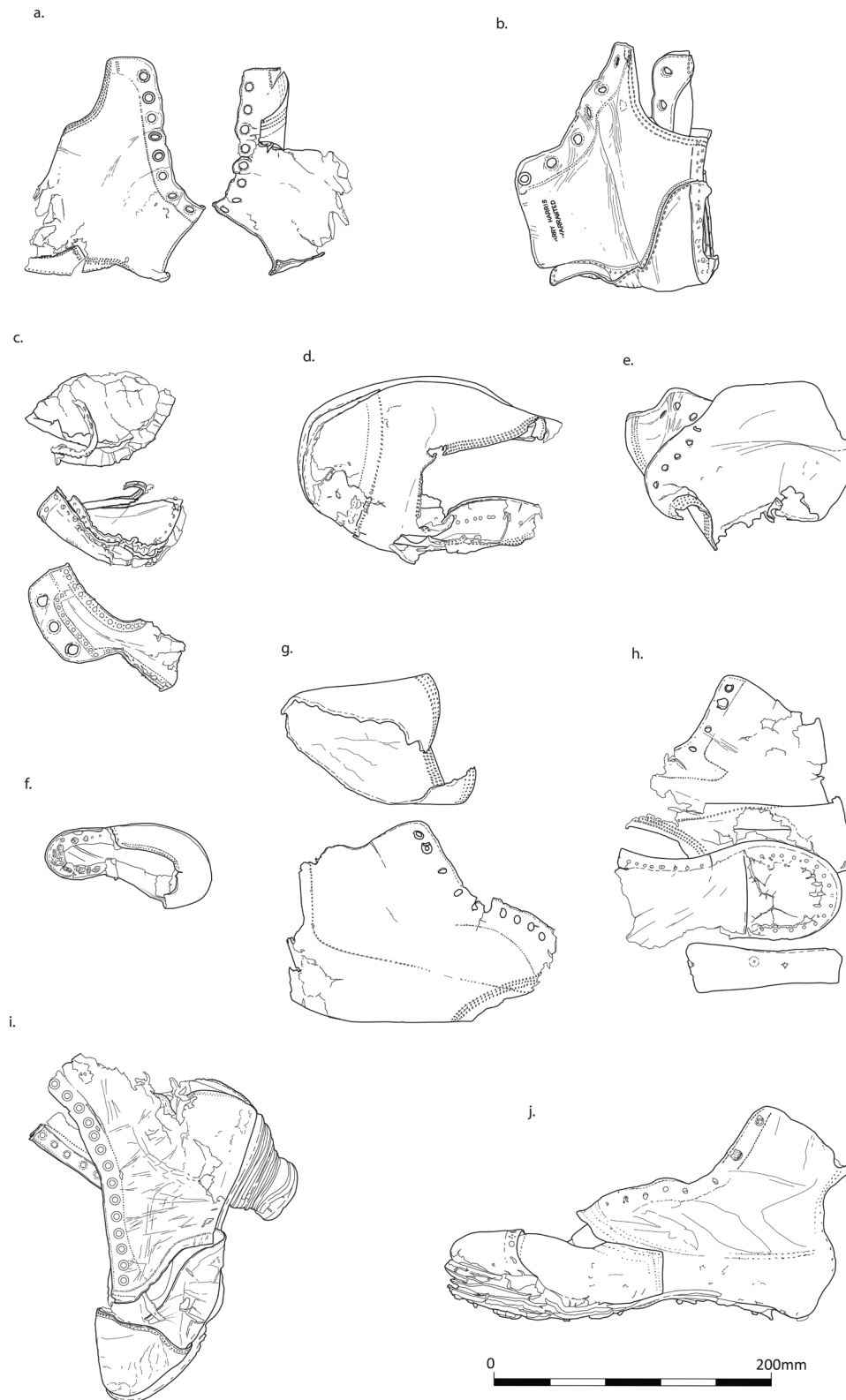

Illus 124 Leather shoe fragments: (a) quarters and lining of ankle boots with central fastening, SF17, Cat 5; (b) upper of boot with central lacing and manufacturer's stamp, SF17, Cat 12; (c) latchet of shoe or boot, SF17, Cat 10; (d) vamp, Cat 15; (e) quarters, Cat 15; (f) infant's left shoe, SF77, Cat 4; (g) vamp and quarters fragment, Cat 18; (h) sole and quarters fragment, Cat 18; (i) boot with central fastening, SF17, Cat 13; (j) right boot with central fastening, Cat 17

9.12.4 Styles

Six shoes have rounded toes (Catalogue nos 1, 4, 16, 17, 19 and 21). Two have oval toes, while two have broad, almost square toes (Catalogue nos 14, 18, 20 and 22). There is only one example of a pointed toe (Catalogue no. 13). Nine uppers are complete enough to be identified as boots, not shoes. All of these have lace holes for central fastening (Catalogue nos 1, 5, 12, 13, 14, 15, 16, 17 and 18). One upper was probably not a boot, perhaps a high shoe, with a latchet with only three lace holes (Catalogue no. 10).

9.12.5 Soles

The most complete soles within the assemblage usually have an outer sole, often covering only the forepart, a midsole and an insole. The midsole often consists of two or more thicknesses, sometimes incorporating strap-like pieces (Catalogue nos 6, 17, 18, 20 and 21). Two insoles have raised ribs with tunnel stitching for attachment to the midsole (Catalogue nos 1 and 7). The insoles have the grain side uppermost.

9.12.6 Heels

The assemblage included nine heels. The simplest, on an infant's sole, was made of a single lift of leather (Catalogue no. 4). Four had four or five leather lifts and are 15mm high (Catalogue nos 1, 2, 16 and 21). Two had seven or eight lifts; one has a height of 17mm, the other of 30mm (Catalogue nos 17 and 3). Two had 10 or 11 lifts, with one of these also having a black composite top piece, possibly of rubber; these had heights of 33 and 45mm (Catalogue nos 13 and 14). Two other soles bear impressions of heels (Catalogue nos 18 and 23).

9.12.7 Uppers

Uppers consisted of vamps and quarters. Eight uppers also had toe caps (Catalogue nos 2, 9, 13, 16, 17, 19, 21 and 31). Two quarters were made of one piece (Catalogue nos 12 and 15). Eight were composed of two pieces, with a central closed seam at the rear (Catalogue nos 1, 2, 5, 13, 14, 16, 17 and 18). Toe caps, vamps and quarters were joined together with lapped grain-flesh stitching channels.

These stitching channels were often in pairs, forming a band enclosing decorative round perforations. Sometimes, these perforations were separated by pairs of dots or, in one case, by four dots forming a diamond shape (Catalogue nos 16, 21 and 17). Usually, the seams joining vamp and quarters had double grain-flesh stitching channels, but four examples had triple rows of stitching, and one had four, made up of two double rows (Catalogue nos 5, 16, 17, 18 and 20). The rear of quarters were sometimes reinforced with backstraps, running from lasting margin to close to top edge. These could be either external (Catalogue nos 2 and 12) or internal (16 and 17). On other examples, internal stiffeners were used; these were usually semi-circular in shape and did not extend as far as the top edge (Catalogue nos 1, 13, 14 and 37). Evidence for tongues is very slight. Boot no. 2 had a two-part tongue, consisting of two approximately rectangular fragments; two other items may have had tongues (Catalogue nos 16 and 36).

Ten shoes had lace holes for a central fastening. One only had three lace holes; these were on a strap-like latchet (Catalogue no. 10). The others had between six and 19 lace holes and were part of ankle boots (Catalogue no. 2 – eight pairs; no. 5 – eight pairs; no. 12 – six pairs; no. 13 – 14 pairs; no. 14 – 19 pairs; no. 15 – seven pairs; no. 16 – eight pairs; no. 17 – eight pairs; no. 18 – ten pairs). All the boots had metal eyelets, although no. 18 only had them for the top two pairs of lace holes. Boots 17 and 18 also had metal hooks at the top of the columns of lace holes. Boot no. 15 had no evidence for lace-hole facings, in contrast to the rest, where the facings and stitching for them survived. On Boot no. 18, the stitching for the lace-hole facing extends backwards for approximately 15mm near the fifth (from top) lace hole, at the point where the leg of the boot bends. This was presumably to prevent the leather splitting on the fold. Boot no. 14 had a woven black fabric lace still in place. It also had a black fabric material lining forming a 45mm wide band inside the top of the leg. Four other uppers had linings; one lining had a reddish covering, of neither leather nor woven fabric (Catalogue nos 2, 5, 17 and 18).

Boot no. 12 has a maker's name stamped on one side of the quarters. It is incomplete; what

survives reads: 'RRY HARRIS WARRANTED' On the other side of the quarters is stamped the number '7'.

9.12.8 Wear

The footwear showed signs of wear; the parts most affected include foreparts of soles, heels, toes of vamps and rear of quarters. There is only very slight evidence for repairs. Three soles had been patched with clump soles, which had been nailed on. Two of these were on the forepart, the third on part of the waist. This last item was made of reused leather, which has stitching channels on it (Catalogue nos 2, 14 and 17).

9.12.9 Sizes

Thirteen soles or uppers were complete enough for an estimate to be made of modern shoe size. Shoe sizes are based on internal measurements, but these are not always possible, when uppers are very stiff. Where external measurements have been used, these have been adjusted. A fourteenth shoe has '7' stamped on it.

The smallest shoe was a child's 1 (continental 16½). Otherwise, sizes ranged between a child's 10 (continental 28) and an adult 7 (continental 41), with two examples of an adult 2 (continental 34). The shoe with a pointed toe was an adult 2–3 (continental 34–35) and was almost certainly a woman's shoe. Some of the smaller boots could have belonged to either women or youths.

9.12.10 Conclusions

This is a small but significant assemblage. Riveted shoes date from after 1853, and were at their most common from the 1880s until the end of the First World War. They were produced in large numbers in factories and were typical cheap working wear (Thomas 1996: 167). Riveted construction indicates that this was cheap, mass-produced footwear. However, the backstraps, stiffeners, linings and facings show that attention to detail was not sacrificed, and that these boots were designed to be reasonably sturdy. The size range suggests the wearers were both children and adults; the children included a small infant. The adults included at least one woman.

9.12.11 Catalogue of illustrated items

► **Cat 4. Infant's left shoe.** Sole, heel and upper of infant's left shoe. Outer sole L: 117mm; Forepart W: 51mm; Heel L: 38mm, W: 36mm, H: 4mm; Inner L: approx 112mm. Modern shoe size approx child's 1, continental 16½. SF77.

► **Cat 5. Quarters and lining of ankle boot with central fastening.** Quarters has a double grain-flesh stitching channel, stitch length 1.5mm, for central closed back seam, machine sewn. Stitching also indicates position of backstrap, now missing. Lining matches quarters with identical stitching and lace holes. Surviving height *c* 110mm. SF17, bag 1 of 7.

► **Cat 10. Latchet.** Latchet of shoe or boot, with three lace holes with metal eyelets, with a diameter of 7.5mm and set 22mm apart. Also, lace-hole facing or lining, matching latchet. SF17, bag 5 of 7.

► **Cat 12. Upper of boot with central lacing and with manufacturer's stamp.** Upper of boot with central lacing, comprising one-piece quarters, backstrap and lace-hole facing or lining. Surviving L: approx 170mm, H: 135mm. An adult 7 would have an inner length of 271mm. SF17, bag 6 of 7.

► **Cat 13. Boot with central fastening.** Sole, heel and upper of boot with central fastening. External L: *c* 240mm; Forepart W: 70mm; Waist W: 39mm; Heel L: 44mm, W: 40mm, H: 33mm, but possibly originally less, as lifts are separating. Modern shoe size adult 2–3, continental 34–35 (allowing for adjustment for external measurements). SF17, bag 7 of 7.

► **Cat 15. Right boot with central fastening.** Right boot, comprising small sole fragments, vamp with lining and quarters with lace holes for central fastening. Vamp L: *c* 180mm, W: (throat) *c* 120mm, Th: 1–1.5mm; Quarters H: approx 95mm, Th: 2–2.5mm; overall L: approx 230mm. Modern shoe size adult 2, continental 34. Context FA1, Layer B.

► **Cat 17. Right boot with central fastening.** Right boot with central fastening comprises sole and upper. L: 250mm; W: (forepart) 85–90mm, W: (vamp) 90mm, W: (waist) 60mm; Heel W: 65mm,

H: 17mm; Quarters H: (excluding sole and heel) *c* 140mm. Modern shoe size adult 3–4, continental 35½–37, allowing for adjustment from external measurement. Context FA1, Layer B.

► **Cat. 18. Right boot with central fastening.** Parts of right boot with central fastening, comprising waist and seat of sole, vamp, two pieces of quarters, two fragments of lining and one piece of lace-hole facing. Upper L: approx 270mm; Quarters H: 145mm. Modern shoe size adult 6–7, continental 39–41, allowing for adjustment from measurements from upper. Context FA1, Layer B.

9.13 The worked bone

Dawn McLaren

9.13.1 Overview

Three hand-carved handles for iron knives were recovered from the Gasworks (Illus 121). A tapering cylindrical bone handle with a rounded butt and a drilled cylindrical socket along its length designed to hold the iron tang of the implement, and two matching sub-rectangular scale plates with incised geometric decoration, came from the northern area of excavation (Test Pit 4/A, SF5 and Test Pit 1/ (P0004)). Another pair of rectangular scale plates remain attached to the iron (steel?) tang of a razor or knife, secured in position by two widely spaced rivets (SF79; Context (N0085)). The first two examples are probably personal implements, carried on the person and put to general use including food preparation and consumption, while the latter may be from a razor or knife.

9.13.2 Catalogue

► **Handle fragment.** Fragment of a tapering, sub-cylindrical bone handle, split across the narrow elongated drilled socket for the iron tang of the implement, resulting in one half of the handle being lost. The drilled tang socket is 38mm in length and 5mm in diameter, terminating sharply in a narrow point. The handle is squared at the narrow, open end, expanding gently in width along the length to terminate in a rounded butt. The surfaces have been smoothed but lack any polish. A deep oblique gouge and a patch of pitted erosion on the external surface are likely to be post-depositional damage.

L: 67mm; W: 10–20mm. SF5. Context: TP4/A (north). Illus 121.

► **Handle.** Two sub-rectangular bone handle plates, plano-convex in cross-section, with incised geometric decoration, remain attached to the scale tang of an iron implement, probably a knife. The plates are squared at the narrowest end and gently expand in width along the length to a wide, squared butt, currently coated in corrosion from the terminal of the knife tang. The plates have been secured to the tang by three equally spaced iron pegs (Diam: 3.5mm). The rounded surfaces are decorated by two fine, parallel, transverse, incised lines which flank the iron pegs. To either side of these lines, running up the edges of the handle on both faces, are a series of closely and evenly spaced, short oblique incised lines. Towards the blade-end of the handle, these decorative markings gradually soften as the result of rubbing from use. There is a high sheen across the surfaces from handling. L: 95mm; W: 17–22mm; Th: 18mm. Context: TP1/P0004 (north). Illus 121.

► **Handle.** Two sub-rectangular bone handle plates, rectangular in cross-section, with steeply bevelled tapering edges, which remain attached to the scale tang of an iron implement, possibly a razor or knife. The plates are squared at the narrowest end, the bevelled edges expanding gently in width along the length to terminate in a rounded butt. Both faces of the handle are flat and plain and have been secured in position by two widely spaced, narrow, circular pegs (Diam: 2mm). L: 75mm; W: 15.5–18.5mm; Th: 13mm. SF79. Context: near Area N, N0085. Illus 121.

9.14 The worked stone

Dawn McLaren

9.14.1 Overview

A single bar-shaped slate whetstone (not illustrated) came from Context FA2, Layer B and is undoubtedly related to the maintenance of iron blades and other tools. It is likely that this tool would have been used in the smithy located in the west of the site during the later phases of the complex's operations.

► **Whetstone.** Rectangular bar of slate with squared, vertical edges. One saw-cut squared narrow end remains; opposite end is broken and original length

of stone is unknown. One long vertical edge has a regular series of linear, oblique, tool marks running along length; opposite edge has overlapping, diametrically opposed oblique tool marks forming a cross-hatched texture. Surface spalls have detached from one face, the other is scratched and damaged but lacks evidence of extensive use. L: 220mm; W: 39–40mm; Th: 18mm. Context FA2, Layer B.

9.15 The wood

Andrew Morrison & Dawn McLaren

9.15.1 Overview

Degraded wooden planks and broken timber fragments were noted among the levelling and demolition deposits but few preserved sufficient surfaces to enable close identification. It is probable that any good-quality timber was stripped out of the Gasworks building at the time of demolition to be sold on and reused elsewhere.

A few timber items are worthy of further note. These include 14 staves from a wooden barrel which came from Area 1A, Vault 9, Layer B. It is likely that this was a whisky barrel, measuring approximately 692mm in original height, which had been repurposed as an open-top barrel for temporary storage and transportation of coal tar, indicated by the thick internal coating and external spills of once-viscous black tar. Robust iron brackets have been added to opposing sides of the barrel, which would

have held rectangular beams to facilitate transport, and a lead or tin plaque has been fastened with numerous small iron nails to three of the staves; the plaque is now corroded and illegible. An original circular bung survives, which appears to have been sealed with wax.

Four planks with spacers (SF25a–d; Area K) form part of a composite object, also associated with extraction and processing of coal tar. The planks have been sandwiched together horizontally, one atop the other, separated by long, narrow wooden spacers or runners which have been nailed to the top and bottom of the planks, running the width of the plank at each end. The edges of the short sides of the planks are cut at a 45° angle, and are successively shorter in length, forming an overall V-shape when stacked together. Thick coal tar is present on all faces, concentrating on the lower faces of the planks. The accumulation and morphology of the coal tar suggests that it flowed through the gaps between the planks when viscous and there may have been some form of mesh fixed with nails along the top edge of the planks, now lost.

Further lengths of degraded timber, likely to be components of dismantled internal structural fixtures and fittings, were noted across the excavated area, including a section of a plank-built block (SF4a–b) which had been used to block a gap between two brick walls in Area D (Context D0014).

10. DISCUSSION

The New Waverley development has afforded a unique opportunity to investigate the New Street Gasworks through excavation, historic building survey and recording of the upstanding remains, artefact analysis and documentary research. This marvel of 19th-century innovation was key to the industrial development of Edinburgh and played a significant role in the history of the Canongate and Edinburgh's Old Town. The archaeological fieldwork encompassed the first major excavation of an urban gasworks in Scotland and has revealed significant evidence of its construction and modification which can be associated with critical developments in technological processes in gas production in Scotland and beyond.

These investigations have provided a wealth of information about the construction and use of the Gasworks buildings and demonstrated the role the Gasworks had to play, not only in the development of industry in Edinburgh, but in the advancement of coal gas technology more widely, with far-reaching effects on British society. Research into contemporary documents, newspapers and legislation demonstrates the enormous impact the Gasworks and its processes had on the residents of the Canongate, for better and for worse.

Why was the development of the New Street Gasworks and coal gas lighting technology so important to Edinburgh during the 19th century? An article written by David Laing for the *Proceedings of the Society of Antiquaries of Scotland* and published in their 1857–59 volume gives some insights into the living conditions in the Old Town of Edinburgh prior to the availability of gas lighting. This article, entitled 'Proposals for Cleaning and Lighting the City of Edinburgh (with original signatures of a number of the principal inhabitants), in the year 1735' presents excerpts of an 18th-century manuscript outlining the deplorable state of the City's streets and the efforts put in place to encourage improvement. The main cause of complaint was the lack of sanitation and the common practice of 'throwing over every kind of filth, ashes, and foul water, at shots, windows or doors in the High Street, or in closes, wynds, or passages of the city' (Laing 1859: 174). Comment is also passed on the lack of illumination of the streets and the adverse effects

on the local residents. The author quotes from an anonymous poem entitled *The Cloaciniad*, written in 1761, which describes:

The dangers which the wretched mortal meets,
Who dares at ten to tred Edina's Streets ...
(Laing 1859: 172)

Laing notes that in 1735, when this proposal was drawn up, the town was 'not then lighted with gas, and the lamps [candle and oil], if I mistake not, were usually extinguished by nine o'clock', and quotes from Fergusson's poem, 'Auld Reekie', that those wishing to traverse the streets after this hour had to carry lanterns 'to guide them through the dangers of the night' (ibid: 176). One of these dangers of the unlit streets was described by Laing as 'that so soon as St Giles' clock struck ten, the windows were simultaneously opened for a general discharge [of waste] ... and the streets and closes resounded with one universal cry, Gardyloo!' (ibid: 177). Laing quotes Sir Walter Scott, who states that 'family resided above family, each habitation occupying one story of the tall mansion, or land ... accessible by one stair, which, common to all the inhabitants, was rarely cleaned and imperfectly lighted' (ibid: 178). The darkness of the Edinburgh streets was also known to encourage those of an unsavoury character to prowl the city unchecked. In the early 16th century, the Scottish poet Dunbar 'makes mention of the "Stinking Style", a covered passage leading from the north side of St Giles' Church to the opposite side of the High Street, known as the Luckenbooths. It existed and retained its name for at least three centuries, in the very heart of the city, and was a noted place for filth, assaults and robberies' (ibid: 172).

It is in this context that the New Street Gasworks were proposed and, by some, welcomed. The limitations that the hours of darkness placed on the activities of the populace were now relieved, and gas lighting of the streets, houses and establishments of Edinburgh facilitated longer working hours, feeding the City's industrial revolution. The illumination of the streets of Edinburgh went hand-in-hand with the perception of a city 'on the rise' and the New Street Gasworks represents an innovation in chemical engineering that heralded a new era in Edinburgh's development.

Alongside Glasgow, the first major coal gas production centre to be opened in an urban setting in Scotland, the New Street Gasworks led the way; soon gasworks were being established in the surrounding areas of the rapidly expanding city and across Scotland. As well as Edinburgh and Glasgow, Cotterill lists 31 further gas companies formed in Scotland up to 1833, including several in settlements on the outskirts of Edinburgh and Glasgow, for example in Leith, Penicuik, Port Glasgow and Paisley, as well as numerous companies in locations across Scotland as diverse as Alloa, Arbroath and Ayr, Campbeltown and Cupar, and Aberdeen, Dundee and Inverness (Cotterill 1976: 120–1). The continual modification and expansion of the Gasworks complex, as demonstrated by the numerous intercutting, overlapping and overlain structural elements revealed during the excavation, are indicative of the increasing demand for gas lighting across the city, which was sustained until the end of the 19th century, when electric lighting began to overtake what was, by that time, seen as an outmoded technology. The development and sprawl of the Gasworks complex at New Street is well documented by cartographic evidence but, as already noted, analysis of the contemporary documentary records reveals that the cartographic survey process could not, at times, keep up with the pace of the construction and additions to the Gasworks infrastructure, resulting in discrepancies between the map evidence, the documentary records and the surviving structural features exposed in the ground. As a result of the excavation, six broad phases of development of the Gasworks could be traced through the surviving structural features, but inevitably some areas and building remains could not be reconciled with the contemporary cartographic and documentary records.

Among the mass of red brick, stone and metal, exposed beneath the concrete of the New Street Bus Depot, it has proved difficult to isolate the work of the many individual hands that contributed to the development of the Gasworks and led to its success over its decades of operation. Many of the individuals associated with the operations of the New Street Gasworks, such as John Grafton, were pioneers in their field and were responsible for innovative developments in gas-production technology. This included the continual process of

refining techniques and engineering new systems to produce higher-quality products while also reducing the negative impacts of the noxious by-products. Of all the engineers involved in the New Street Gasworks, it is probably Grafton's innovations that are the most apparent among the excavated features, in the form of the surviving refractory clay retorts and their associated benches and furnaces.

Nineteenth-century complaints over inconsistency in the quality of the gas, the smell of the product and the pollution resulting from the gas-production process all drove improvements in the technology employed by the New Street Gasworks. Even the by-products from the production process were exploited to their fullest. Coke, coal tar and sulphur are but a few of the materials produced during the gas-production processes which were sold on for other uses. This was often lauded as the Gasworks fulfilling its responsibilities to keep pollution to a minimum, but it appears to have been encouraged by the high prices that could be charged for these waste products; a sideline industry that could be more profitable than the gas production itself.

To the residents of the expanding city whose water was poisoned and whose air was polluted by the noxious fumes and sulphurous odours, the New Street Gasworks was also a source of misery. The wealthier residents of the Canongate, with the financial means to move, sold their properties and took up residence in more salubrious and genteel areas of the city after the establishment of the Gasworks. By the mid-19th century, the demographics of the Canongate had entirely changed; the area was populated by the poorer classes and maintenance of the properties had decreased. Archaeological evidence of the Gasworks' attempts to reduce the pollutants entering the city's groundwater, and the adjacent stream that fed the Calton Hill Brewery, was identified during the excavations in the form of several wells that were intended to provide the Gasworks with a sustainable and independent water supply. However, it is known from 19th-century legal complaints that these efforts were not entirely successful.

The voices that are less easy to hear in the story of the New Street Gasworks are those of the workers themselves. Recollections of working conditions at other contemporary and later gasworks have to be used as a proxy in this instance, but we

know that the day-to-day toil would have been physically demanding, set within the context of the extreme heat of the furnaces and the noxious fumes of the retort houses. It did not go without notice that those corrosive gases produced within the Gasworks building during its operations were so severe that they caused the iron and steel fittings to degrade; a fact witnessed in the poor condition of the surviving iron objects, tools and fixtures from the site. In later phases of the site's development we see the employment of galvanised steel fittings, perhaps an attempt to thwart the worst effects of these destructive fumes. However, less concern appears to have been expressed over the welfare of the employees of the Gasworks, and one is left to imagine the effects that such fumes had on those who inhaled them every day, leading to both respiratory diseases and skin conditions. Burns, crush injuries and chemical poisonings must have been typical effects on a gasworker's life. The foundation of a National Union of Gasworkers and General Labourers in March 1889 arose from these poor working conditions.

A rich photographic archive of the Gasworks buildings during the later years of its operation and prior to its demolition survives in the collections of Historic Environment Scotland's National Historic Environments Records. These have proved a valuable source of information in the identification of the various underground structures exposed during excavation. They provide an insight into the former appearance of some of the features, such as the retort benches and chimneys, for which only the foundations survived at the time of excavation. Individual artefacts, such as the scroll-shaped decorative plaster console brackets (see 9.2 'The architectural plasterwork') and architectural ironwork (see 9.8.3 'Architectural ironwork' above), provide glimpses of some of the other areas of the Gasworks, perhaps the office suites or public areas.

The removal of above-surface structures and machinery in the early 20th century made identification of the function of many features exposed during excavation problematic, such as the various large platforms for engines and machinery. It is clear that as many of the metal tools, fittings and fixtures as possible were stripped out and salvaged from the Gasworks for scrap or reuse, meaning that the surviving evidence is incomplete. Survivals

include tools used to feed and clear the furnaces and retorts and fittings that relate directly to the gasworking process, including an intact Glenboig fireclay retort, an iron retort inspection box and spoked hand wheels that would have been used to adjust the valves to pipes that transported water and gas in the exhaust house.

As well as the 19th-century Gasworks, the archaeological investigations at the New Waverley project also uncovered significant evidence of earlier activity on the Canongate, stretching back to the late 12th century. This expands on evidence for the occupation of the Canongate backlands identified during previous archaeological works, confirming the presence of medieval and post-medieval backland occupation identified by Gooder during the original evaluation works (Gooder 2000). Evidence for medieval occupation has also been identified to the east of the present site at 22 Calton Road (Jones & Holden 2003) and at Canongate Poorhouse (Engl forthcoming), confirming the wide extent of these medieval backlands north of the Canongate.

The excavation across the Gasworks and at the other sites in this part of the Canongate, including the PA1(A) and PA1(B) sites (Appendix 1), have therefore revealed pockets of survival of early backland deposits, of medieval and post-medieval date, demonstrating that even on a site as heavily disturbed by industry as the Gasworks, evidence for previous land use can survive.

The nearby Poorhouse excavations of 2013 and 2014, associated with the PA1(C) area of the New Waverley development, revealed an area which, like the present site, appears to have been on the periphery of the medieval Canongate Burgh. It was in open cultivation from the 12th/13th century until the development of more formal burgh plots between the 14th and 17th centuries. In this area, the presence of imported ceramics shows that the Canongate remained the preserve of Edinburgh's wealthy mercantile elite until the economic decline of the mid to late 17th century (Engl forthcoming). Unfortunately, at the present site, ceramics were rare in the later medieval period but late-16th- and 17th-century imports were present, reinforcing the evidence for elite occupation of the Canongate area at that time. While the greater part of the pottery assemblage at the present site comprised industrial-produced wares of 19th-century date, a Ch'ien Lung

(c 1760–70) Chinese Export teapot perhaps suggests that the decline in the standing of the area was a prolonged process.

Occasional sections of wall, including two areas where walls contained window bays, evidenced occupation of the present site in the period prior to the Gasworks by significant buildings, likely domestic structures of 18th-century date. The artefacts from these surviving islands of post-medieval backland soils demonstrate a diverse post-medieval community, and as well as a broad array of household ceramics, including imports from China, Italy, Holland and Germany, the assemblage of clay

tobacco pipes, produced both locally and further afield (although having a residual character), forms an important group that illustrates the development of the local pipe production industry and includes the earliest pipe so far identified in Scotland.

The New Street Gasworks and the technology it introduced to the City of Edinburgh changed the face of the Canongate and had far-reaching effects on the living conditions of the local community. The New Waverley development has provided a unique insight into this Gasworks which was at the forefront of Edinburgh's burgeoning industrialisation and heralded the City's progression into the modern era.

APPENDIX 1. THE EXCAVATED EVIDENCE: NEW WAVERLEY AREAS PA1(A) AND PA1(B)

A.1.1 Introduction

The work in PA1(A) (NGR: NT2632 7357) consisted of the opening of four machine-excavated trial trenches to evaluate its archaeological potential. PA1(A) covered an area of approximately 40m × 10m, which had until recently been used as a car park; the modern ground surface was approximately 42.8m AOD (Illus 125). An unbonded rubble stone well was revealed in one trench, while sterile sand was encountered within the other three trenches below modern overburden.

PA1(B) (NGR: NT2636 7395) was located to the east of PA1(A), north of the foot of Tolbooth Wynd. It was a strip of land approximately 20m × 14m (Illus 126) and, as with PA1(A), had been used as a car park; the existing ground level was approximately 42.9m AOD. The area was bounded on three sides by substantial stone and brick walls associated with buildings that formerly occupied the site. These walls contained features related to earlier buildings, including fireplaces and blocked openings, recorded during a historic building survey in May 2008 (Sproat 2008). Sproat's survey indicated that some of the upstanding walls could relate to buildings visible on mapping of 1784 (Illus 128), although the majority are of 19th-century and later date.

A field evaluation was undertaken by the City of Edinburgh Council Archaeology Service (CECAS) in 1997 within the PA1(B) area (CECAS 1997), revealing remains of late-post-medieval stone-built foundations, cellars and drains. An archaeological watching brief on the excavation of four test pits around the perimeter of PA1(B) recorded layers of sand with occasional fragments of brick and tile (Clements & Scott 2006). The archaeological works conducted in 2008 by AOC Archaeology involved excavation across PA1(B) with a basal excavation area of 154m² (Wilson 2008c), identifying truncated stone walls and drains and a fireplace. All these features overlay sterile sand over bedrock. Artefacts associated with post-medieval/modern occupation of the site were recovered, including fragments of pottery, clay pipes and a small bone tool.

A.1.2 Historic background to PA1(A) and PA1(B)

While the PA1(A) and PA1(B) areas appear to have been undeveloped until the post-medieval period, James Gordon of Rothiemay's map of 1647 (Illus 4) depicts a circular structure in the PA1(B) area. This circular feature appears again on Edgar's map of 1765 (Illus 127), apparently incorporated into the west end of a group of buildings. Kincaid's map of 1784 (Illus 128) depicts buildings across both PA1(A) and PA1(B), indicating that the north side of Calton Road (formerly known as the North Back of the Canongate) below Calton Hill had been largely developed by the end of the 18th century. The buildings north of Calton Road appear to have been reconfigured by the time of Kirkwood's map of 1817 (Illus 129), with the circular structure and an adjacent courtyard no longer evident.

However, it is not until the First Edition Ordnance Survey map of 1854 (surveyed 1852) (Illus 130) that the area is shown in detail. The row of buildings along Calton Road in the areas of PA1(A) and PA1(B) are marked as 'Amphion Place', with the 'Calton Hill Brewery' to their immediate east. The path dividing the two areas is marked as the 'Calton Hill Stairs'. This building layout is also visible on the later Ordnance Survey 1877 edition (Illus 20). Workshops belonging to the papermakers Cowan & Company were established at 1 Amphion Place by the mid-1860s (Scottish Book Trade Index).

A.1.3 Results of the PA1(A) archaeological works

In Area PA1(A) beneath modern hardstanding and overburden, between 0.40m and 0.60m of rubble and mixed deposits overlay 2.1m of yellow sand over the natural bedrock. In Trench 2 were the remains of a stone well (Illus 131) constructed of a single course of undressed rubble with no visible bonding material. It had an internal diameter of 1.7m and was over 3m in depth, its base not being reached during excavation. The well had been infilled with a mixed rubble and clay deposit and its vertical cut through the sand was filled with a brown clayey sand deposit, which contained no artefacts. In Trench 4, at the east end of PA1(A), large blocks of sandstone rubble were recorded within overburden.

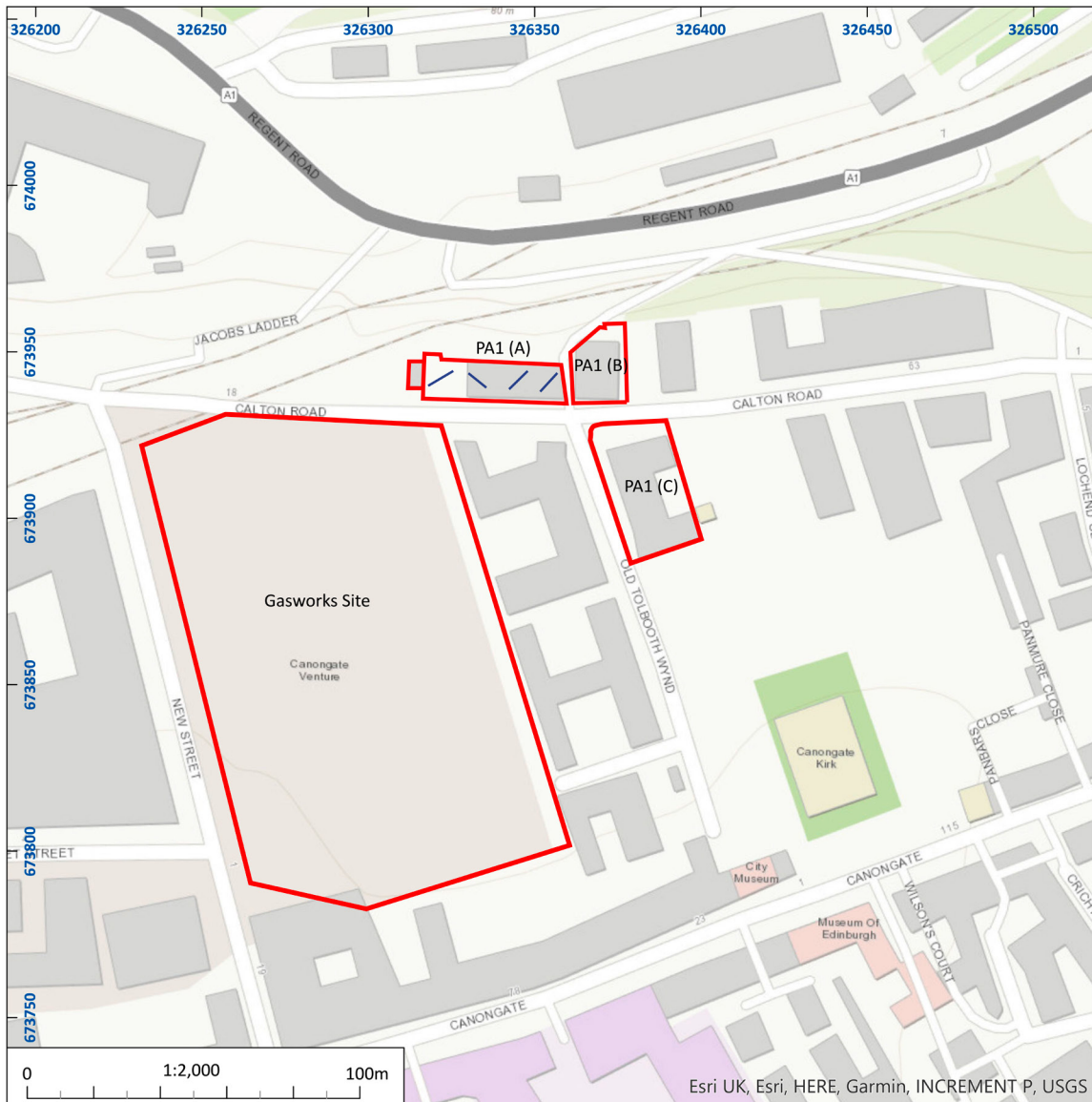
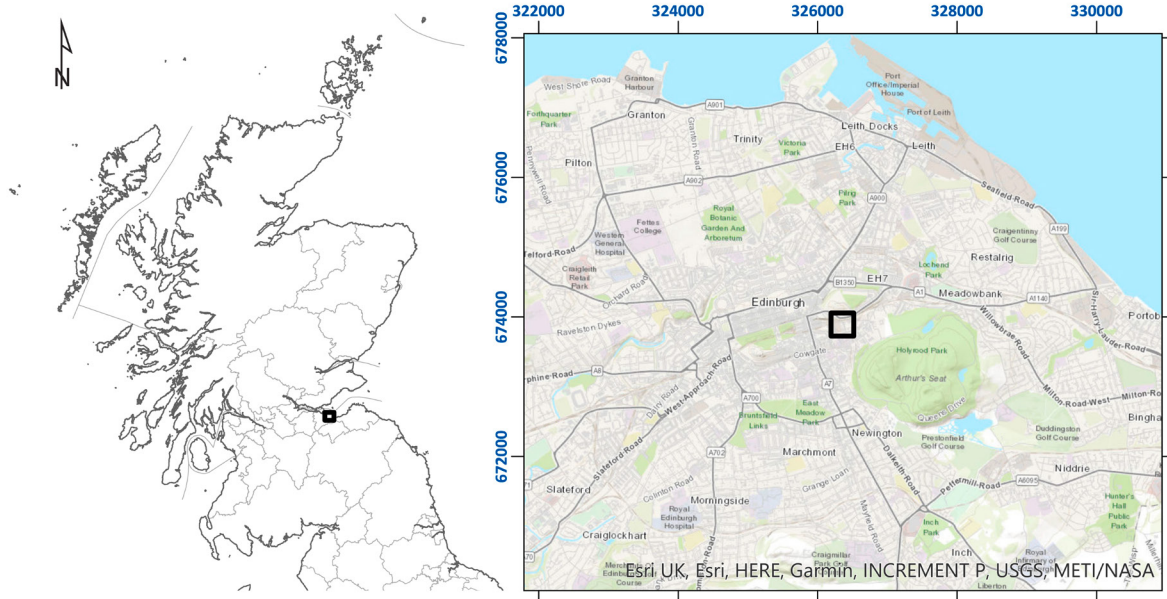

Illus 125 Location of PA1(A) and PA1(B) archaeological works

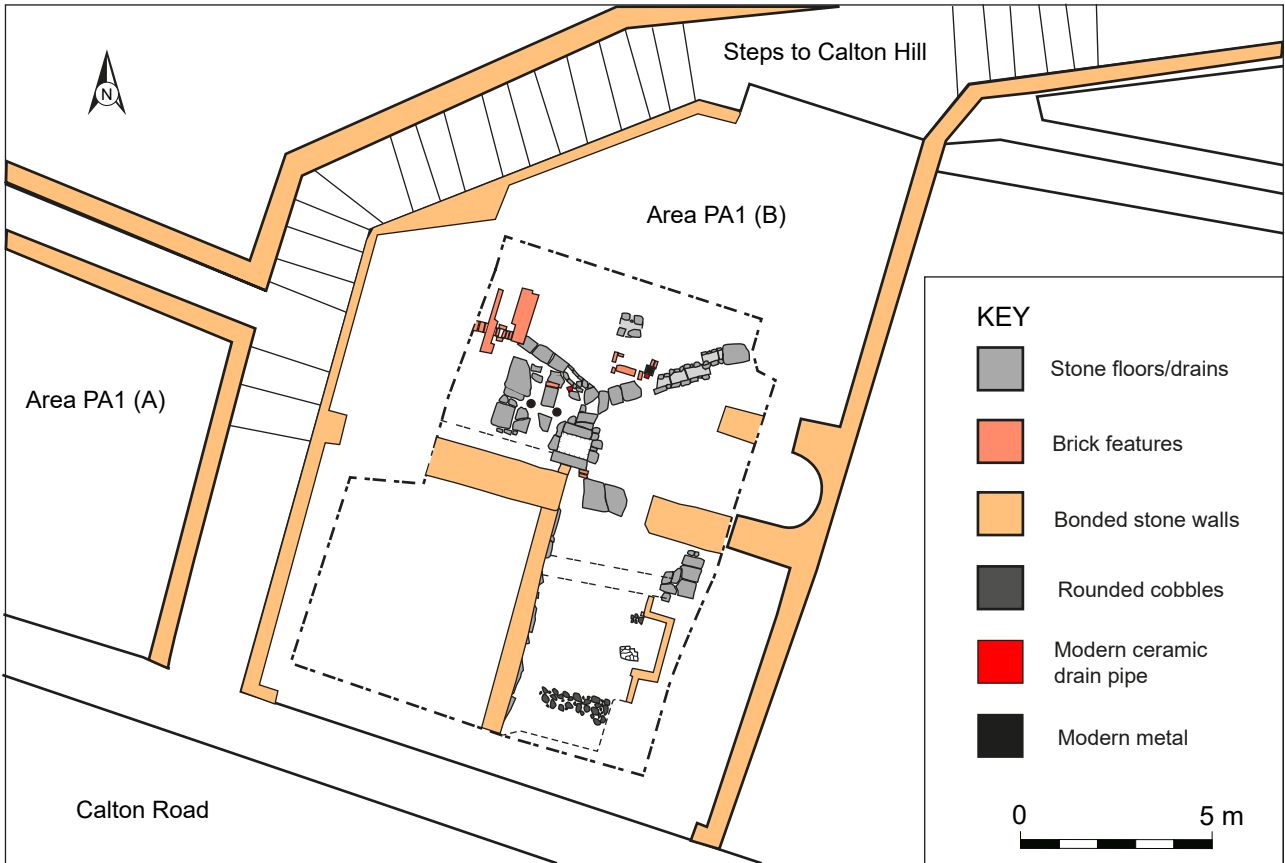

Illus 126 Plan of excavation area PA1(B)



Illus 127 Extract from Edgar's map of 1765

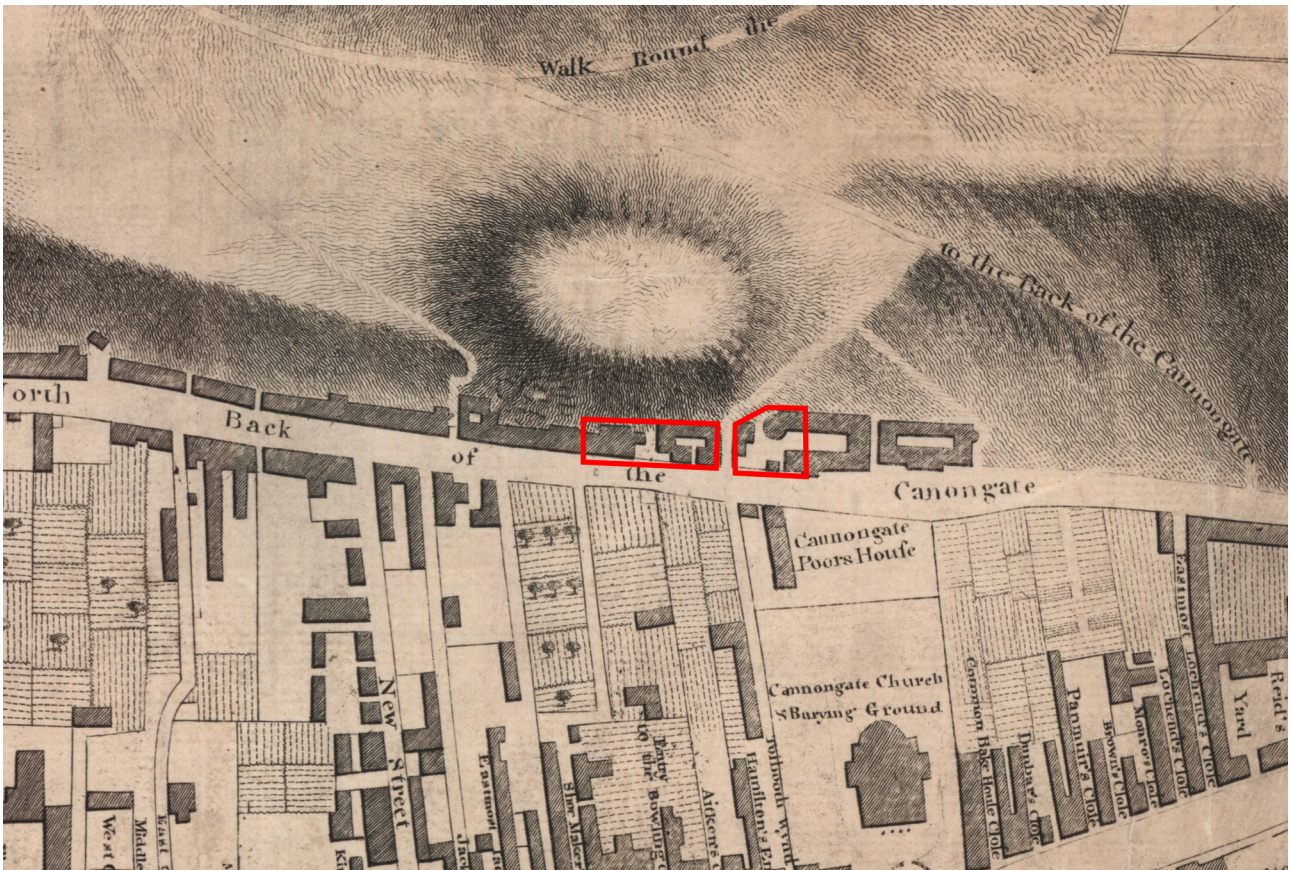

Illus 128 Extract from Kincaid's plan of 1784

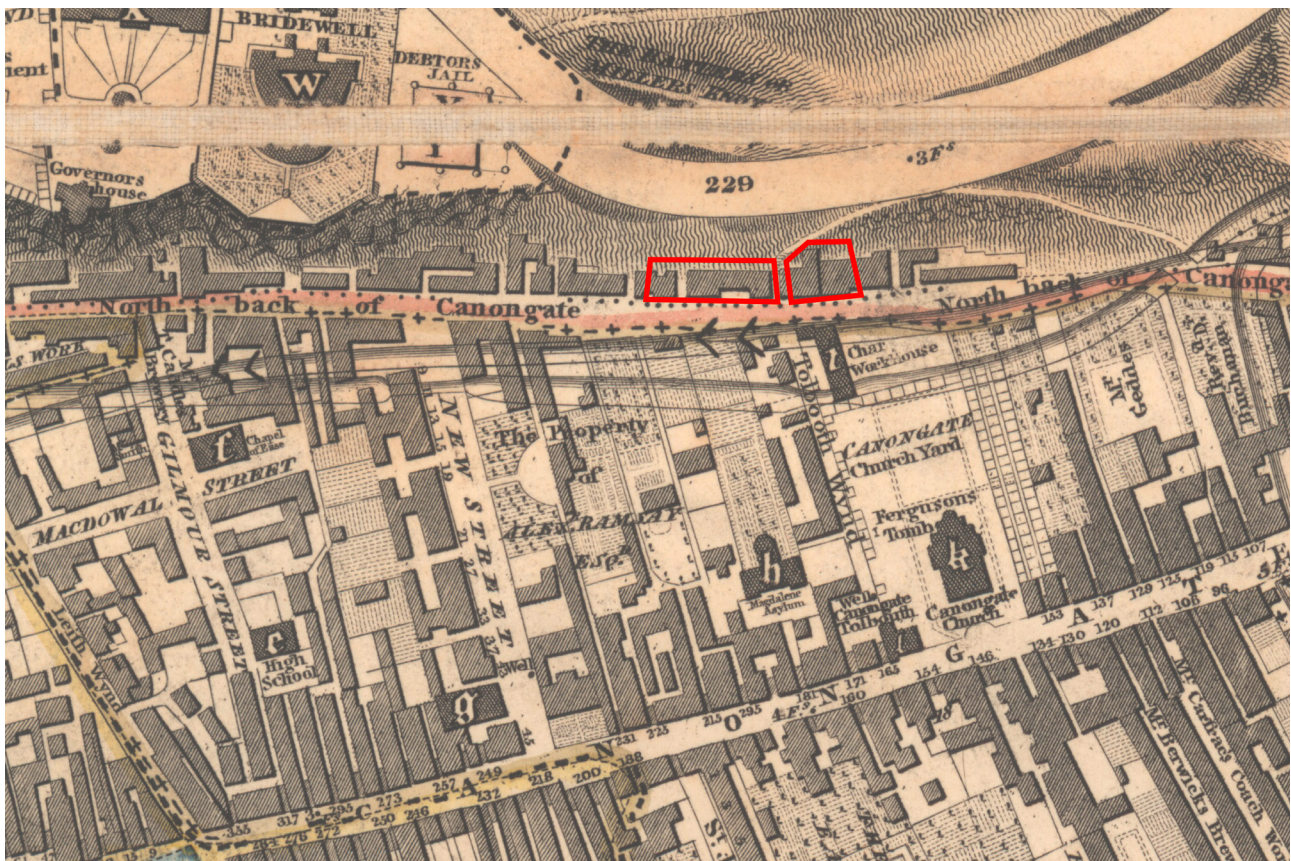

Illus 129 Extract from Kirkwood's map of 1817

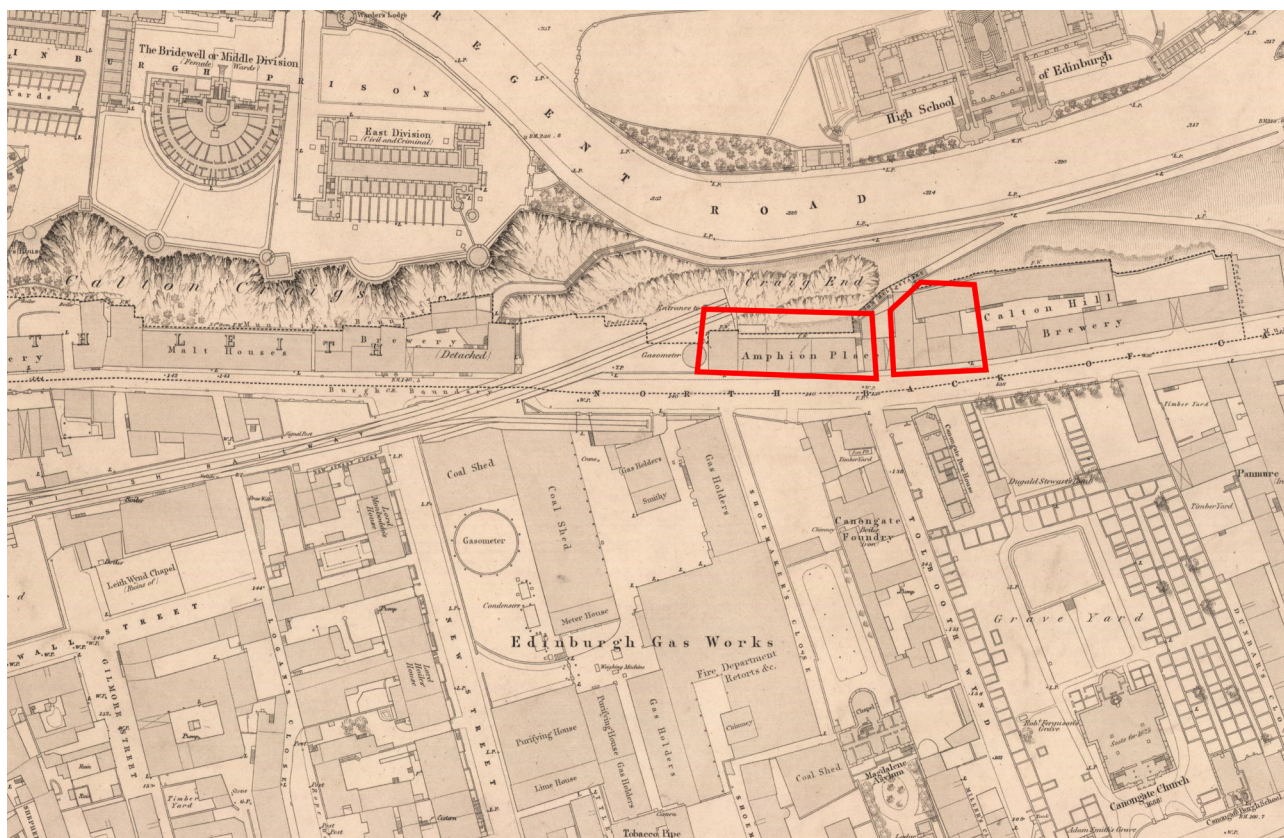

Illus 130 Extract from Ordnance Survey map, surveyed 1852

A.1.4 Results of the PA1(B) archaeological works

Across PA1(B) modern hardstanding and overburden covered between 0.20m and 0.60m of rubble and mixed deposits overlying significant archaeological features (Illus 132), the earliest of which were cut into the sterile yellow sand (8028) overlying the bedrock, which had been cut back into the hill.

A.1.4.1 Fireplace (8018)

The earliest feature recorded was a stone-built fireplace (8018; Illus 133), with two phases of construction in rubble masonry.

The fireplace was 1.65m wide and stood to a maximum height of 1.4m. The northern element of the fireplace was of significantly higher quality than the southern element, topped by a projecting stone corbel. It was stratigraphically earlier than the poorly constructed southern part, which appeared to mimic the original element, incorporating a stone corbel. The wall line on each side of the fireplace had been truncated, to the north by an east/west cut (8026), which contained a fill of angular stone and

clay (8025). Two fragments of post-medieval pottery (SF5) were recovered from a layer of burnt red sand (8030) below the southern wall of the fireplace. In front of the fireplace were floor surfaces formed of stone slabs and cobbling, including an area of heat-affected stone (8019). To the south of the fireplace was an area of large rounded cobbles (8021).

A.1.4.2 Drainage structures

In the north of PA1(B) was a complex of stone-capped drainage features, (8001) and (8013), cut into sand (8028) and leading into a central sump/silt trap (8029). To the west, drain (8001) was constructed of large capstones over stone rubble side walls and a bedrock base; it ran north-west/south-east before turning towards the south to form a junction with drain (8013) and sump (8029). Drain (8013) (Illus 134), which ran from the north-east towards the central sump to the south-west, was of similar construction to drain (8001) but had a base of irregular flagstones.

The sump (8029) (Illus 135) internally measured 0.83m by 0.60m in plan and was 1.2m in depth. Its



Illus 131 Remains of a stone well in Trench 2, PA1(A) area

north, east and west upper walls were constructed of coursed rubble, bonded with lime mortar, while the south wall comprised a large stone vertical slab. This formed a barrier, 0.55m in height, leaving a gap at the base through which the contents of the drains could flow. The lower section of the sump was constructed of unfrosted red brick. The north wall included a small square opening, approximately 0.25m from the top of the structure, from which the fluid from the drains to the north would have flowed. The base of the sump comprised bedrock to the north and a crushed brick layer to the south.

The brown sandy upper fill of the sump, (8008), contained fragments of clay tobacco pipe, animal bone and ceramic sherds. The lower fill, (8012), a yellow sand with clay lenses, contained fragments of clay tobacco pipe and three small bone tools, SF2a, possibly used in lacemaking (Illus 137, see A.1.6.4 ‘The worked bone’ below).

A.1.4.3 Floor surfaces and walls

To the south of drain (8001), flagstones (8003) may have formed a truncated floor surface above

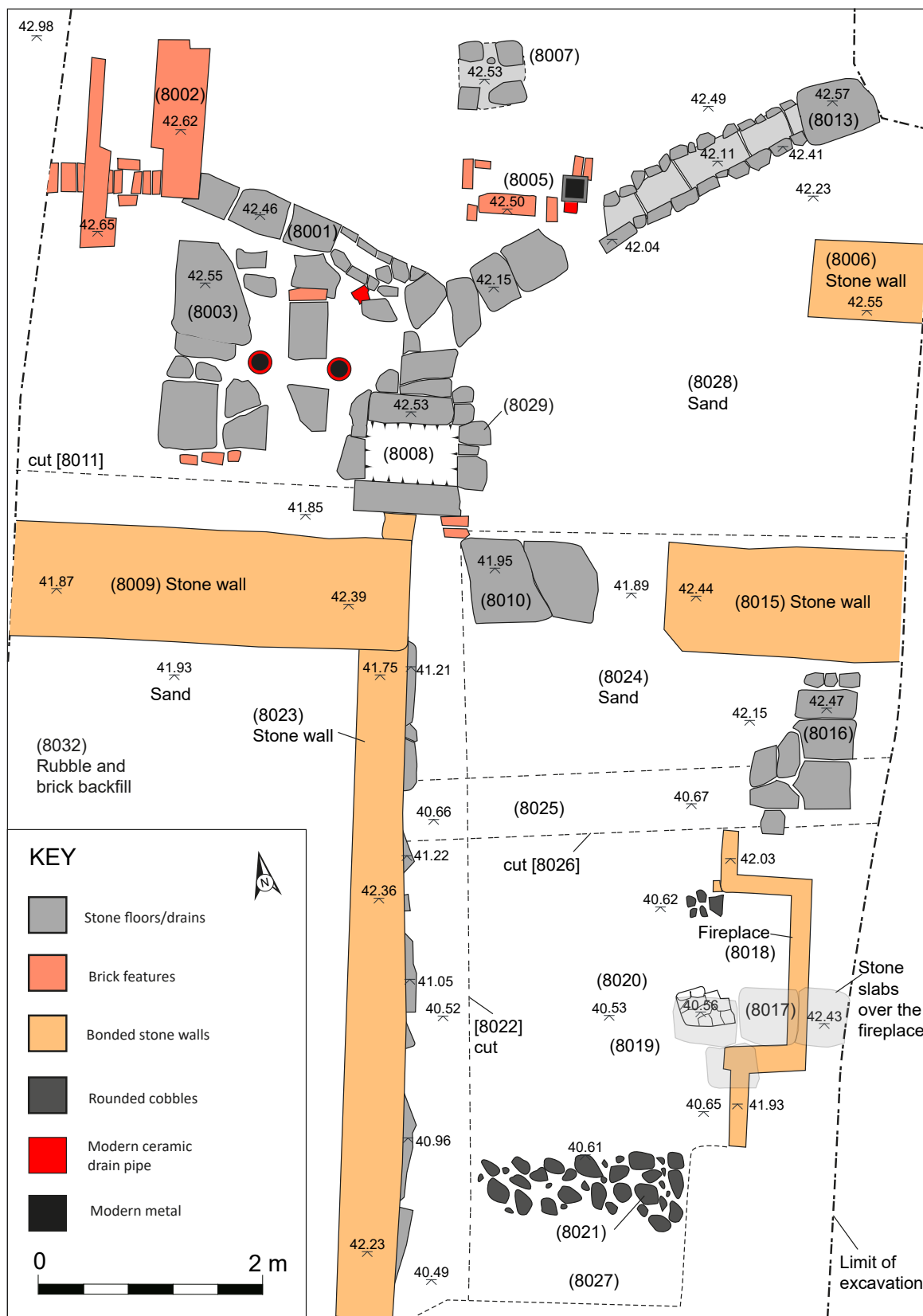

Illus 132 Plan of the PA1(B) excavation area



Illus 133 Early stone-built fireplace (Context 8018), PA1(B) area



Illus 134 Drain (8013) after excavation, PA1(B) area



Illus 135 Stone-built sump (8029), PA1(B) area

the drains and sand (8028). Further sections of truncated flooring were recorded to the south as (8010), (8016) and (8017). While these separate areas of flooring could not be connected, they were all located at approximately the same level (*c* 42.5m AOD).

Sump (8029) was truncated on its southern side by the remains of a north/south-aligned stone wall, (8023), bonded with coarse grey cement. This feature was at least 7m in length, with a maximum surviving height of 1.25m. Its stone foundation sat over a thin layer of rubble which overlay sand (8028).

The eastern terminal of the base of a later east/west-aligned stone wall (8009) was 1.2m wide and sat above the north end of wall (8023). This later wall was also bonded with cement, and its western end was in alignment with a stone buttress located against the boundary wall, 6m to the west. A 5m gap separated (8009) from a further east/west-aligned, 0.95m wide, stone wall section, (8015), of similar

construction. This was aligned with a buttress supporting the eastern boundary wall and stood over redeposited yellow sand with angular stone inclusions, (8024) above sand (8028). Also overlying (8024), in the gap between the two sections of wall, was truncated flagstone surface (8010). To the north of wall (8015) was a section of less substantial stone wall remnant, (8006), again in line with a stone buttress on the eastern boundary wall.

A.1.4.4 Late features

Later features included an area of brick flooring, (8002), approximately 1.6m × 1.2m in plan, comprised of unfroged bricks bonded with coarse grey cement. This was constructed over a stone-capped drain, (8001). To the east was a further area of bricks associated with a square metal drain cap (8005). A large collection of animal bones (including semi-articulated horse remains) was recovered from rubble infill (8032) bounded by walls (8009) to the north and (8023) to the east.

A.1.5 The historic building recording

Diana Sproat

In conjunction with the archaeological fieldwork in areas PA1(A) and PA1(B), a programme of historic building recording was undertaken (Sproat 2008), the conclusions of which are summarised here. The survey of area PA1(A) recorded a simple west-facing section of wall, identifying a number of blocked features including two fireplaces. The survey of PA1(B) exposed an east-facing and a south-facing section of upstanding wall. The recorded walls contained various features related to buildings that formerly stood on this site, including fireplaces and blocked openings. The earliest phase of the walls possibly dated back to the 18th century, while later additions and alterations occurred during the 19th and 20th centuries.

A.1.5.1 PA1(A)

Buildings on the PA1(A) site were first established between the 1760s and the 1780s, first appearing

on Kincaid's map of 1784 (Illus 128). There appears to have been considerable development by the beginning of the 19th century and by the time of Kirkwood's map of 1817 (Illus 129) a new layout of buildings is apparent, the remains of which were visible during the building recording work. It is not known, however, whether the buildings from the late 18th/early 19th century were incorporated into a larger building plan around the mid-19th century, or if they were completely demolished and replaced.

The main access to the building in PA1(A) was probably in the south wall. A range and a fireplace (Illus 136), identified in the west-facing elevation, probably represent remains of a kitchen area or perhaps a scullery. The building was at least two storeys in height with a bricked-up first-floor window to the north. Ordnance Survey mapping indicates that the buildings were present until at least 1931 (not illustrated).



Illus 136 Detail of the range and fireplace, west-facing elevation

A.1.5.2 PA1(B)

Buildings have stood on PA1(B) since the middle of the 18th century, although a circular structure pre-dates these. However, the recorded structures were probably established no earlier than between 1784 and 1817. In the wall to the west, a buttress was present which marked a division between buildings identifiable on Ordnance Survey maps of 1852 (Illus 130) and 1877 (Illus 20). This also appears to mark separate phases of the building, with the pre-1817 building to the south and the later, mid-19th century, building to the north, incorporating a living space. The wall to the south may have been rebuilt at a later stage, due to drastic changes visible in the stonework, perhaps when the Calton Hill Stairs were established in the early 19th century. The south-facing wall had several phases visible, with the building stepped back against Calton Hill. In the centre of the ground floor there were blocked windows, possibly related to a mid-19th-century structure that was later demolished. A north/south wall could also be seen to the east of this, representing the north/south wall visible on both the 1852 and the 1877 Ordnance Survey maps. A first-floor window, recorded on the west wall of PA1(B), contained a date stone of '1900', which may indicate a reuse of the stonework, or a rebuilding or raising of the structure at first-floor level.

A.1.5.3 Conclusion

The wall remains recorded on the PA1(A) and PA1(B) areas demonstrate multiple phases of the former buildings in the area. In the 1860s, the papermakers 'Cowan & Co' had a workshop at 1 Amphion Place (Scottish Book Trade Index). It is likely, therefore, that these buildings were set up as workshops and commercial premises, although the presence of fireplaces suggests that occupation of some parts of the buildings may have had a more domestic nature, despite the large industrial premises that developed to the east and on the opposite side of Calton Road.

A.1.6 The ecofact and artefact assemblages

A.1.6.1 The animal bone

Jackaline Robertson

A small quantity of animal bone (3.3kg) came from a sump and rubble layer in the PA1(B) area of

excavation and was subject to environmental analysis to identify the bones to species and element, where possible; no animal bone was found at the adjacent PA1(A) site. The methodology used to identify and record the animal bone is outlined in full within the PA1(B) animal bone report included in the site archive.

The faunal assemblage was found to be small, comprising 58 individual bones which were recovered from rubble layer (8032) and from the fill (8008) of sump (8029). Nineteen fragments were identified as the semi-articulated remains of a horse, two as cattle, and a single bone was recognised as sheep/goat. The remaining 36 bones could not be identified to species but are described as large mammal bone. Preservation of the remains varied from poor to excellent but most were of moderate condition.

The horse bones (Q=19) are consistent with the burial of semi-articulated remains within rubble layer (8032). The skeletal elements present include the thoracic vertebra, lumbar vertebra, humerus, radius, ulna, patella, femur, tibia, astragalus and cuneiform. Examination of epiphyseal fusion indicates that this animal was older than three years at the time of death. Also from Context (8032) were part of a cattle skull and horn. A single sheep/goat tibia was recovered from the fill of sump (8029). The proximal epiphyses were unfused, indicating an animal younger than 3.5 years at the time of death.

Little evidence of butchery survived. Two small and shallow cut marks were noted on one of the large mammal bones but insufficient details survive to prove useful and there was no evidence of pathology or trauma affecting any of the bones examined.

The recovery of horse remains from post-medieval and later urban contexts in Scotland generally, and Edinburgh specifically, is not uncommon. Similar evidence has been noted among the faunal assemblages recovered from a ditch on East Market Street (Robertson 2018: 42–3) and Advocate's Close, Edinburgh (Robertson 2017: 53). While it was not possible to establish the cause of death for the horse, the semi-articulated state of burial strongly implies that this animal's carcass was not butchered for secondary products (eg skin, glue etc). Instead, it is likely that this horse was buried fully articulated and its remains were subsequently disturbed during construction works on the site.

In contrast, the cattle and sheep/goat bones are probably discarded food waste which has become reworked and dispersed after incorporation within midden and levelling deposits.

A.1.6.2 The ceramics

George R Haggarty

A small group of post-medieval ceramics was recovered but little can be inferred about these due to their small size and damaged condition, except that the sherds from Contexts (8020) and (8030) are likely to be 17th century in date and a sherd from the rim of a bowl (SF5) is an unusual form and one not local to the Edinburgh area. A possible 15th- or 16th-century import (SF1) from London is also recognised from the PA1(A) area of excavation.

- ▶ **SF1.** One small finely gritted redware body sherd internally glazed and sooted on its exterior. Fabric is not consistent with local or Low Countries ceramics and may have been produced in London; possibly 15th or 16th century. Context (100). PA1(A).
- ▶ **SF3b.** Two sherds indicative of late-19th-century date: One almost complete two-tone ginger beer/stout bottle impressed above its base with [GRAY / ? / PORTOBELLO]; one small white dipped body sherd of standard white earthenware; one small cork closure white dipped bottle probably by Gray's of Portobello. Context (8014). PA1(B).
- ▶ **SF4.** Three sherds, almost certainly 17th century in date: Scottish Post-Medieval Oxidised Ware body sherds, glazed on both surfaces, too small to determine what kind of vessel they derive from. Context (8020). PA1(B).
- ▶ **SF5.** Two sherds, 17th century in date: one very thick Scottish Post-Medieval Oxidised Ware body sherd almost certainly from a large knife-trimmed jug; one internally glazed rim sherd from what looks like a bowl with decoration on its rim. This is in the form of a raised round iron-stained knob which has been impressed with a ring and dot. On either side of this are two bands of wavy line decoration. Context (8030). PA1(B).

A.1.6.3 The glass

Andrew Morrison

A small glass assemblage (94.6g), comprising three sherds of bottle glass, 14 sherds of window glass, and 12 sherds from a bowl with inverted rim, was recovered from PA1(B). These fragments date from around the mid-18th to 19th century and were all retrieved from two secure contexts, the upper and lower fills of a sump (8029). The recovered bottle and window glass represent an assemblage of finds typical of late post-medieval sites in Scotland from around the early 18th century onwards (Murdoch 2011: 100). While some of the green bottle glass recovered may date to the earlier 18th century, its date of deposition could be much later as bottles were often refilled and reused over long periods of time prior to breakage and eventual discard (ibid). Similarly, window glass can see long periods separating its date of manufacture from its date of deposition.

The green bottle glass ranges in colour from light to dark olive green, with another clear glass sherd with frosted band also present. The green bottle glass body sherd (SF1c), and the green bottle glass neck sherd (SF2c) are both hand-blown and are thought to date from around the mid-18th to early 19th century. The clear glass bottle sherd (SF2c) is thought to come from the shoulder of the bottle; a thin diagonal, frosted decorative band is present on the sherd. Twelve fragments from a clear, slightly opaque, hand-blown glass bowl (SF2c) with a rounded, inverted rim were recovered from the bottom fill of the sump. Not enough of the object is represented to accurately assess the diameter, but it has the appearance of a lamp shade or similar. Fourteen sherds of window glass (SF2c) were also recovered, ranging from a light green aqua to completely colourless. Two potential edges are present within the window glass sherds, which are all thought to be 19th century in date.

A.1.6.4 The worked bone

Andrew Morrison

Three worked bone tools were recovered during excavations in the PA1(B) area.

The tools (Illus 137) are probably associated with dressmaking or lacemaking, and are well worn,



Illus 137 Worked bone tools from PA1(B), SF2a, (8012)

showing polishing and reshaping through extended use. Two of the three tools are likely reused, one probably originally a toothbrush, the other probably a utensil handle, repurposed as dressmaking tools. The objects were retrieved from Context (8012), the lower fill of a sump, from which fragments of 19th-century clay tobacco pipe were also recovered. No close parallels for the reused tools have been found, which is likely a reflection of their bespoke production and use.

The Edinburgh Postal Directory of 1879–80 lists a Miss Rae, Dressmaker, as having a residence/place of business at 60 Amphion Place, which corresponds with the location of the archaeological investigation. Miss Rae is recorded as having shared the premises belonging to a Mrs Carroll, a Midwife. The heavy wear on the tools, combined with the repurposing of a broken toothbrush and utensil handle as dressmaking tools, suggests a relative degree of poverty for the owner of these tools.

► **Possible ribbon-trimming tool.** Long, flat, spatulate shape, with worn, rounded ends. One end slightly thicker, one long edge with a slight worn

notch/constriction near centre. Sides are rounded through wear. Thickness tapers towards narrower end. Ends and sides are polished through use, with bifacial offset wear at each end. Object is fractured in two, likely post-depositionally. Likely 18th–19th century. L: 166.6mm; W: 22.7–25.4mm; Th: 2.8–6mm, Mass 26.6g. SF2a. Context (8012).

► **Dressmaking/lacemaking tool.** Long, tapering spatulate shape, highly polished through wear. Flat wide end shows bifacial offset wear. Rounded sides taper inwards to a broken end with a rounded rectangular section. Thickness tapers towards wide end. Broken end is polished from use, showing that the tool was still used post-breakage. The words 'LAIRD' and 'EDINBURGH' are incised in the top face, with the royal coat of arms between the two. Possibly a broken bone handle from a utensil or similar, repurposed as a dressmaking tool. L: 96.7mm; W: 6.5–16.2mm; Th: 3.4–6.5mm, Mass 7.6g. SF2a. Context (8012).

► **Dressmaking/lacemaking tool.** Long, parallel-sided tool, flattened ovoid in section. Rounded/pointed end with offset bifacial wear, straight

parallel sides to a pronounced shoulder tapering into a constricted neck, widening out to a slightly triangular head shaped through offset bifacial wear. Head appears heavily worn, likely saw extended use. Thickness remains fairly constant over length of tool. Possibly a reused bone toothbrush with broken head, repurposed as a dressmaking tool. L: 106.6mm; W: 7.5–13.3mm; Th: 3.4–5.4mm, Mass 10.5g. SF2a. Context (8012).

A.1.7 Discussion

Although no dating material was recovered from the layer of sand that covered bedrock in areas PA1(A) and PA1(B), it may have been deposited prior to any buildings being erected on the north side of Calton Road. This sand deposit was tentatively associated with the 18th-century development of the area north of Calton Road by the excavator (Wilson 2008c), perhaps being deposited to form a stable layer on which construction could take place.

The stone well cut through the sand layer in PA1(A) likely pre-dates the development of Amphion Place, and may therefore date to the 18th century, perhaps being associated with the buildings established by 1784 (Illus 128). No evidence for the buildings visible on late-18th- and 19th-century maps to the north of Calton Road was encountered within area PA1(A).

Cartographic records suggest that, apart from a circular structure depicted on Gordon's map of 1647 (Illus 4), no buildings were present within the PA1(B) area until the later post-medieval period, an interpretation corroborated by the archaeological record. No remains of the circular structure visible on Gordon's map, and later on Edgar's map of 1765 (Illus 127), were present, suggesting that it had been demolished prior to the development of the area as

Amphion Place by the middle of the 19th century (Illus 130).

In Area PA1(B), remains of the fireplace (8018) were stratigraphically early and may therefore be associated with one of the buildings depicted on Edgar's map of 1765 (Illus 127). However, its precise date of construction is unknown. Stone-capped drains (8001) and (8013) were also interpreted as early features, as the associated sump, (8029), had been truncated by the later north/south-aligned wall (8023). The sump may have acted as a silt trap for the associated drains to the north.

The alignments of the later stone wall remnants, commonly lining up with buttresses on the surrounding boundary walls, indicates that they were likely associated with the 19th-century redevelopment of the site. The east/west-aligned walls above earlier wall (8023) appeared to line up with walls depicted on the First Edition Ordnance Survey map, surveyed in 1852 (Illus 130).

Finds recovered from the PA1(B) excavation included many from the fills of the drainage sump (8029). These included fragments of pottery and three bone tools (SF2a), one of which was incised 'LAIRD EDINBURGH'. These may have been associated with lacemaking.

In summary, the surviving archaeological deposits and structures belonged to the later post-medieval period and are associated with 18th- and 19th-century buildings depicted on contemporary maps. Given the location of PA1(A) and PA1(B) close to areas of 19th-century industry, including the New Street Gasworks to the south, the Calton Hill Brewery to the east, and evidence that Amphion Place was occupied by commercial premises, the buildings were perhaps utilised as industrial workshops, supported by the identification of lacemaking tools.

11. ACKNOWLEDGEMENTS

This work was possible thanks to the financial support of New Waverley Advisors Ltd. The fieldwork phase of the project was funded by Mountgrange Ltd. This

long-running series of excavations was managed in the field by Donald Wilson and overseen by Ronan Toolis and John Gooder. The writers would like to extend a particular note of thanks to John Lawson, CECAS, for his advice and guidance throughout the project.

12. REFERENCES

12.1 Cartographic sources

- Historic maps referenced were accessed from the National Library of Scotland website at <https://maps.nls.uk/>.
- Ainslie, John 1780 *City of Edinburgh*. Edinburgh. <https://maps.nls.uk/view/74400070>. Accessed 18 January 2018.
- Anonymous 1828 *Plan of Edinburgh & Leith exhibiting all the present & intended improvements, etc.* Edinburgh: W Hunter & C Smith. <https://maps.nls.uk/view/102190477>. Accessed 18 January 2018.
- Braun, Georg & Hogenberg, Franz c 1582 *Edenburgum Scotiae Metropolis*. <https://maps.nls.uk/view/00003284>. Accessed 18 January 2018.
- Edgar, William 1765 *Plan of the City and Castle of Edinburgh / by Willm Edgar architect anno 1765*. A. Dury. <https://maps.nls.uk/view/102190561>. Accessed 18 January 2018.
- Gordon, James, of Rothiemay 1647 *Bird's Eye View of Edinburgh in 1647 / by James Gordon of Rothiemay*. Edinburgh: W. & A. K. Johnston (published c 1870). <https://maps.nls.uk/view/102190447>. Accessed 18 January 2018.
- Kay, J 1836 *Kay's Plan of Edinburgh*. <https://maps.nls.uk/view/74400077>. Accessed 18 January 2018.
- Kincaid, Alexander 1784 *A Plan of the City and Suburbs of Edinburgh*. Edinburgh. <https://maps.nls.uk/view/74400071>. Accessed 18 January 2018.
- Kirkwood, James 1821 *Kirkwood's New Plan of the City of Edinburgh*. Edinburgh. <https://maps.nls.uk/view/74401133>. Accessed 18 January 2018.
- Kirkwood, Robert 1817 *This Plan of the City of Edinburgh and its Environs*. Edinburgh: Kirkwood & Son. <https://maps.nls.uk/view/74400074>. Accessed 18 January 2018.
- Lancefield, Alfred, 1851 *Johnston's plan of Edinburgh & Leith*. Edinburgh: W. & A. K. Johnston. <https://maps.nls.uk/view/74400080>. Accessed 18 January 2018.
- Lizars, William Home 1835 *Plan of Edinburgh and Leith. From the best Authorities. Engraved expressly for the Letter Carriers Directory, By W.H. Lizars, 1835. Including: Map of the County of Mid-Lothian Ten miles round Edinburgh, and Leith*. Edinburgh: James Ballantyne & Co. <https://maps.nls.uk/view/117741944>. Accessed 18 January 2018.
- Lizars, William Home c 1837–8 *Plan of Edinburgh and Leith. From the best Authorities. Engraved expressly for the Letter Carriers Directory, By W.H. Lizars. Including: Map of the County of Mid-Lothian Ten miles round Edinburgh, and Leith*. Edinburgh: James Ballantyne & Co. <https://maps.nls.uk/view/120326539>. Accessed 18 January 2018.
- Ordnance Survey 1854 (Surveyed 1852) *Edinburgh Sheet 30, scale 1:1056*. <https://maps.nls.uk/view/74415446>. Accessed 18 January 2018.
- Ordnance Survey 1881 (Revised 1877) *Edinburgh Sheet 30, scale 1:1056*. <https://maps.nls.uk/view/74415668>. Accessed 18 January 2018.
- Ordnance Survey 1895 (Surveyed 1894) *Edinburgh Sheet III.8.11, scale 1:500*. <https://maps.nls.uk/view/74415762>. Accessed 18 January 2018.
- Ordnance Survey 1895 (Surveyed 1894) *Edinburgh Sheet III.8.12, scale 1:500*. <https://maps.nls.uk/view/74415763>. Accessed 18 January 2018.
- Ordnance Survey 1908 (Revised 1905) *Edinburghshire Sheet 003.08 (includes: Edinburgh), scale 25 inch to the mile*. <https://maps.nls.uk/view/82877412>. Accessed 18 January 2018.
- Ordnance Survey 1914 (Revised 1912–13) *Edinburghshire Sheet 003.08 (includes: Edinburgh), scale 25 inch to the mile*. <https://maps.nls.uk/view/82877415>. Accessed 18 January 2018.
- Ordnance Survey 1933 (Revised 1931) *Edinburghshire Sheet 003.08 (includes: Edinburgh), scale 25 inch to the mile*. <https://maps.nls.uk/view/82877418>. Accessed 18 January 2018.
- Ordnance Survey 1948 (Surveyed 1946) Sheet NT 2673NW – A, scale 1:1250. <https://maps.nls.uk/view/102734363>. Accessed 8 September 2022.
- Wood, John 1823 *Plan of the City of Edinburgh, including all the latest and intended improvements*. Edinburgh: P Brown & T Nelson. <https://maps.nls.uk/view/74400026>. Accessed 18 January 2018.

12.2 Documentary sources

12.2.1 Edinburgh City Archives

Dean of Guild Court Box 1799/17 Warrant granted 25 April 1799.

12.2.2 Historic Environment Scotland (HES)

DPM 1930/195/1/3 Dick, Peddie & McKay Archive: Block plan showing new extension to garage by J R McKay ARIBA 4 Melville Street, Edinburgh, December 1935.

EDD 747/1 Scottish Gas Collection: Edinburgh, New Street Gasworks Survey site plan Alex Masterson, Engineer Edinburgh and Leith Corporation's Gas Commissioners (deposited by Scottish Gas 1980) Linen Dyeline February 1915.

EDD 747/3 Scottish Gas Collection: Edinburgh, New Street Gasworks Structural elevation sections and detail of proposed workshop Alex Masterson, Engineer Edinburgh and Leith Corporation's Gas Commissioners (deposited by Scottish Gas 1980).

EDD 747/5 Scottish Gas Collection: Edinburgh, New Street Gasworks Unfinished contract plan of coal shed extension Edinburgh Gas Light Co, 25 Waterloo Place, Edinburgh.

Digital images for the following available at https://canmore.org.uk/site/52212/edinburgh-new-street-gasworks?display=collection&GROUPCATEGORY=5&collection_items_page=1. Accessed 13 December 2017:

SC 1311260 Scottish Gas Collection: Interior view of gasworks, New Street, Edinburgh. Date *c* 1906.

SC 1311261 Scottish Gas Collection: View of gasworks, New Street, Edinburgh. Date *c* 1906.

SC 1311262 Scottish Gas Collection: View of gasworks, New Street, Edinburgh. Date *c* 1906.

SC 1311283 Scottish Gas Collection: View of gasworks exhauster house, New Street, Edinburgh. Date 1906.

SC 1360184 Scottish Gas Collection: Interior view of New Street Gasworks, Edinburgh.

SC 1360190 Scottish Gas Collection: Interior view of machinery at New Street Gasworks, Edinburgh. Date *c* 1900.

SC 1360191 Scottish Gas Collection: Interior view of New Street Gasworks, Edinburgh. Date 26/12/1906.

SC 1360192 Scottish Gas Collection: View of New Street Gasworks, Edinburgh. Date 26/12/1906.

Digital images for the following available at https://canmore.org.uk/site/52212/edinburgh-new-street-gasworks?display=collection&GROUPCATEGORY=5&collection_items_page=2. Accessed 13 December 2017:

SC 1432920 Scottish Gas Collection: View of men at work at New Street Gasworks, Edinburgh, unloading coal from railway wagons. Date *c* 1902.

SC 1432921 Scottish Gas Collection: View of demolition of horizontal retorts at New Street Gasworks, Edinburgh. Date *c* 22/9/1911.

SC 1432922 Scottish Gas Collection: View of demolition of horizontal retorts at New Street Gasworks, Edinburgh. Date 1911.

DP 207855 RCAHMS Collection: View of south boundary wall and gateway at 179 Canongate, leading into site of Gasworks, New Street, Edinburgh. Date 10/11/2014.

DP 207861 RCAHMS Collection: Detail of part of south boundary wall to site of former Gasworks, New Street, Edinburgh. Date 10/11/2014.

DP 207862 RCAHMS Collection: Detail of part of south boundary wall to site of former Gasworks, New Street, Edinburgh. Date 10/11/2014.

DP 207863 RCAHMS Collection: Detail of part of south boundary wall to site of former Gasworks, New Street, Edinburgh. Date 10/11/2014.

DP 207864 RCAHMS Collection: View of part of Gasworks, New Street, Edinburgh, with courtyard leading off Old Tolbooth Wynd. Date 10/11/2014.

DP 207865 RCAHMS Collection: View of part of Gasworks, New Street, Edinburgh, with courtyard leading off Old Tolbooth Wynd. Date 10/11/2014.

DP 207866 RCAHMS Collection: View of part of boundary wall to Gasworks, New Street, Edinburgh, off Old Tolbooth Wynd. Date 10/11/2014.

DP 207867 RCAHMS Collection: View of part of boundary wall to Gasworks, New Street, Edinburgh, off Old Tolbooth Wynd. Date 10/11/2014.

12.2.3 National Records of Scotland (NRS)

- NRS GD1/1246/1_a Records of Edinburgh Gas Company: Letter book of Edinburgh Gas Company. Dates 20 Oct 1823–4 Dec 1829.
- NRS GD1/1246/1_b Records of Edinburgh Gas Company: Letter book of Edinburgh Gas Company: 20th October 1823 to John McKean.
- NRS GD1/1246/1_c Records of Edinburgh Gas Company: Letter book of Edinburgh Gas Company: 22nd November 1823 to John King, Gas Light Co, Liverpool.
- NRS GD1/1246/1_d Records of Edinburgh Gas Company: Letter book of Edinburgh Gas Company: 24th November 1823 to John Thomson Esq. of Gas Co, Glasgow.
- NRS GD1/1246/1_f Records of Edinburgh Gas Company: Letter book of Edinburgh Gas Company: 5th May 1824 to R. Miller, Esq., City Gas Ltd. Co, London.
- NRS GD1/1246/1_g Records of Edinburgh Gas Company: Letter book of Edinburgh Gas Company: 8th March 1825 to Emmanuel Wait, Esq. of Gas Cos' Office, Bristol.
- NRS GD1/1246/1_h Records of Edinburgh Gas Company: Letter book of Edinburgh Gas Company: 28th March 1825 to D. Benham, City Gas Works, London.
- NRS GD1/1246/1_j Records of Edinburgh Gas Company: Letter book of Edinburgh Gas Company: 30th November 1825 to John Thomson, Gas Co, Glasgow.
- NRS GD283/6/233_a Messrs Fairbairn, Lightbody & Cownie Chartered Quantity Surveyors and Valuers Edinburgh: Correspondence, valuations, lists of feus, tables of Land Transactions, plan, precognition in causa Muir vs The Gas Commissioners re ground & well at 30 Back Canongate, Edinburgh. Dates 1908. Bartholomew's Large Plan of Edinburgh and Leith & Pencil sketch of Muir's Brewery.
- NRS GD283/6/233_b Messrs Fairbairn, Lightbody & Cownie Chartered Quantity Surveyors and Valuers Edinburgh: Correspondence, valuations, lists of feus, tables of Land Transactions, plan, precognition in causa Muir vs The Gas Commissioners re ground & well at 30 Back Canongate, Edinburgh. Dates 1908.

Precognition Report of James Alexander Robertson Durham, C A, Edinburgh.

- NRS GD504/3/97/1–14 Papers of the Sprot family of Haystoun, Peeblesshire: Estate and Household Papers: Documents relating to Captain Hay's investments in the Edinburgh Gas Light Company. Dates 1818–1829.

Includes:

- NRS GD504/3/97/2 Edinburgh Gas Light Company An Act for Enabling the Edinburgh Gas Light Company to raise a further Sum of Money; and for other Purposes relating thereto. Royal Assent, 23rd March 1829. Great George Street, Edinburgh: Spottiswoode & Robertson.
- NRS GD504/3/97/5 Edinburgh Gas-Works June 17 1822 Report of the Governor and Directors being a Committee of Management of the Edinburgh Gas Light Company to The General Meeting of the Proprietors of said Company, to be held on Monday the 17th day of June, 1822, in terms of their Act of Parliament.
- NRS GD504/3/97/7 Edinburgh Gas-Works 14th June 1821 Report of the Governor and Directors, being a Committee of Management of the Edinburgh Gas Light Company to The General Meeting of the Proprietors of said Company, to be held on Monday the 18th day of June, 1821, in terms of the Act of Parliament.
- NRS GD504/3/97/11 Prospectus of the Edinburgh Gas-Light Company, Edinburgh 1st March 1817. Edinburgh: John Moir.
- NRS GD504/3/97/14 An Act for Lighting the City and Suburbs of Edinburgh and Places Adjacent with Gas 23rd May 1818. Edinburgh: D Hunter Blair & J Bruce (published 1819).

12.2.4 Records of the Parliaments of Scotland

RPS: The Records of the Parliaments of Scotland to 1707, K M Brown et al eds (St Andrews, 2007–2015), 1661/1/122.

12.3 Digital sources

- BGS Geology of Britain Viewer website. Available at <https://www.bgs.ac.uk/map-viewers/bgs-geology-viewer/>. Accessed 8 September 2022.
- Edinburgh Dean of Guild 1799 Annotated Catalogue of the Edinburgh Dean of Guild

- Court, Architectural Plans Part II 1770–1800 Box 1799/17 ‘Warrant granted 25th April 1799’. Available at <https://sites.google.com/site/edinburghdeanofguild/home/january-to-december-1799-1>. Accessed 14 December 2017.
- The Galvanizers Association, entry for ‘History of Galvanizing’. Available at <https://www.galvanizing.org.uk/hot-dip-galvanizing/history-of-galvanizing/>. Accessed 17 July 2018.
- Historic Environment Scotland Designations Portal Listed Building No. 27582. Available at <http://portal.historicenvironment.scot/designation/LB27582>. Accessed 11 October 2022.
- Historic Environment Scotland Designations Portal Listed Building No. 28434. Available at <http://portal.historicenvironment.scot/designation/LB28434>. Accessed 11 October 2022.
- Historic Environment Scotland Designations Portal Listed Building No. 28437. Available at <http://portal.historicenvironment.scot/designation/LB28437>. Accessed 11 October 2022.
- Scottish Book Trade Index, entry for ‘Cowan & Co.’ Available at <https://data.cerl.org/sbti/001553>. Accessed 6 September 2018.
- Scottish Brick History, entry for ‘Bathville Brick and Fire Clay Works, Armadale, West Lothian’. Available at <https://www.scottishbrickhistory.co.uk/bathville-brick-and-fire-clay-works-armadale-west-lothian/>. Accessed 9 September 2022.
- Scottish Brick History, entry for ‘Glenboig fire-brick production’. Available at <https://www.scottishbrickhistory.co.uk/glenboig-brick-manufacturing-history/>. Accessed 6 September 2017.
- Scottish Post Office Directories – Towns, Edinburgh. Available at National Library of Scotland <https://digital.nls.uk/directories/>. Accessed 3 October 2017.
- 12.4 Secondary sources**
- Adamson, A, Kilpatrick, L & McDonald, M 2016 *Pints, Politics and Piety: The Architecture and Industries of Canongate*. Edinburgh: Historic Environment Scotland. <https://canmore.org.uk/collection/1526718>. Accessed 7 October 2020.
- Angelini, I, Artioli, G & Nicosia, C 2017 ‘Metals and metalworking residues’, in Nicosia, C & Stoops, G (eds), *Archaeological Soil and Sediment Micromorphology*, 213–22. Oxford: John Wiley & Sons.
- Anon 1828 *Considerations Relative to Nuisance in Coal-gas Works: With Remarks on the Principles of Monopoly and Competition as Applicable to These Establishments: Addressed to the Proprietors, Feuars, and Others, in the Vicinity of the Oil-gas Works at Tanfield*. Edinburgh: John Anderson.
- Anon 1840 *Foul Burn Agitation! Statement Explaining the Nature and History of the Agricultural Irrigation Near Edinburgh*. Edinburgh: John Lindsay & Co. <https://archive.org/details/b21356841/page/n5/mode/2up?view=theater>. Accessed 13 December 2017.
- Anon 1866 ‘Manufacture of Gas’, in *The Boy’s Book of Trades and the Tools Used in Them*, 72–88. London: George Routledge and Sons.
- Awty, B 1974 ‘The introduction of gas-lighting to Preston’, *Transactions of the Historic Society of Lancashire and Cheshire* 125: 82–118.
- Baird, G 1959 ‘Our City No. 2: Gas’, *St. Cuthbert’s Monthly Journal* (April 1959).
- Beulah, G K 1990 ‘Samuel Wright of Shelton and his tiles’, *Journal of the Tiles and Architectural Society* 3: 28–32.
- Beckett, I F W 1982 *Riflemen Form: A Study of the Rifle Volunteer Movement 1859–1908*. Barnsley: The Ogilby Trusts.
- Bird, A & Nabb, H 1989 *Stoking Up the Past: A Sketchbook History of the Gas Industry and the Growth of the Gas Workers’ Union in Plymouth*. Bristol: British Gas plc South Western GMB, Southern Region.
- Boog Watson, C B 1923 ‘Notes on the names of the closes and wynds of old Edinburgh’, *The Book of the Old Edinburgh Club* 12: 1–156.
- Bown, C J & Shipley, B M 1982 *South-East Scotland: Soil Survey of Scotland*. Aberdeen: The Macaulay Institute for Soil Research.
- Bradley-Lovekin, T, Roy, M & Sproat, D 2017 ‘Old Tolbooth Wynd 179a Canongate, Edinburgh Heritage Assessment’, unpublished AOC Archaeology report.
- Bradley-Lovekin, T, Roy, M & Sproat, D 2018 ‘Old Tolbooth Wynd 179a Canongate, Edinburgh Historic Building Assessment’, unpublished AOC Archaeology report.
- Bradley-Lovekin, T, Roy, M & Sproat, D 2019 ‘Old Tolbooth Wynd 179a Canongate, Edinburgh

- Archaeology and Historic Building Assessment', unpublished AOC Archaeology report.
- Bullock, P, Fedoroff, N, Jongerius, A, Stoops, G, Tursina, T & Babel, U 1985 *Handbook for Soil Thin Section Description*. Wolverhampton: Waine Research Publications.
- Burn, J S 1829 *The History of Parish Registers in England*. London: Edward Suter.
- Butt, J 1967 *The Industrial Archaeology of Scotland*. Newton Abbot: David & Charles.
- Canti, M G 2017 'Coal', in Nicosia, C & Stoops, G (eds) *Archaeological Soil and Sediment Micromorphology*, 143–5. Oxford: John Wiley & Sons.
- Capital and Labour 1881 'The Employers' Liability Assurance Corporation (Limited)', *Capital and Labour: An Economic, Financial, and Commercial Journal, with which is incorporated 'The Common Good'*, Issue 368 (Wednesday 9 March 1881): i.
- Carter, S, Dennison, E P & Tipping, R 2008 'The Scottish Parliament Archaeological Project', in Holyrood Archaeology Project Team *Scotland's Parliament Site and the Canongate: Archaeology and History*, 1–8. [Society of Antiquaries of Scotland Monograph Series](#). Edinburgh: Society of Antiquaries of Scotland.
- CECAS 1997 'Calton Road, Edinburgh: Evaluation Report', unpublished archive report.
- Chambers, W 1830 *The Book of Scotland*. Edinburgh.
- Civil Engineer and Architect's Journal 1851 'High chimneys: an account of the high chimney of the Edinburgh Gas Works with observations on the principles of its strength and stability. By George Buchanan Esq., F.R.S.E., Civil Engineer (Paper read at the Royal Scottish Society of Arts)', *The Civil Engineer and Architect's Journal* 14: 34–5.
- Clements, V & Scott, L 2006 'Calton Road, Edinburgh Archaeological Watching Brief of SI Works Data Structure Report', unpublished AOC Archaeology report.
- Coghill, H 2008 *Lost Edinburgh: Edinburgh's Lost Architectural Heritage*. Edinburgh: Birlinn.
- Coles, J M 1969 'Scottish Early Bronze Age metalwork', *Proc Soc Antiq Scot* 101 (1968–9): 1–110.
- Commercial Motor 1928 'The growth of a Scottish bus operator', *The Commercial Motor* (25 September 1928): 185–6. Available at the Commercial Motor Archive, at <https://archive.commercialmotor.com/article/25th-september-1928/25/the-growth-of-a-scottish-bus-operator>. Accessed 14 November 2017.
- Cotterill, M S 1976 'The Scottish Gas Industry up to 1914', unpublished PhD thesis, University of Strathclyde, 4 vols.
- Cotterill, M S 1980 'The development of Scottish Gas technology, 1817–1914: inspiration and motivation', *Industrial Archaeology Review* 5(1): 19–40.
- Davey, P J 1992 'Dutch clay pipes from Scotland', in Gaimster, D & Redknap, M (eds) *Everyday and Exotic Pottery from Europe c 650–1900*, 279–89. Oxford: Oxbow.
- Davey, P 1997 'The pipes', in Rains, M J & Hall, D W (eds) *Excavations in St Andrews 1980–89: A Decade of Archaeology in a Historic Scottish Burgh*, 94–9. Perth: Tayside & Fife Archaeological Committee.
- Davey, P & Norton, J 2013 'The importation of clay tobacco pipes into Ireland in the seventeenth century, with special reference to the Dutch-style material', *Journal of the Académie Internationale de la Pipe* 6: 141–53.
- Dennison, E P 2005 *Holyrood and Canongate: A Thousand Years of History*. Edinburgh: Birlinn.
- Dennison, E P 2008 'The medieval burgh of Canongate', in Holyrood Archaeology Project Team *Scotland's Parliament Site and the Canongate: Archaeology and History*, 59–68. [Society of Antiquaries of Scotland Monograph Series](#). Edinburgh: Society of Antiquaries of Scotland.
- Dobney, K & Rielly, K 1988 'A method for recording archaeological animal bones: the use of diagnostic zones', *Circaea* 5: 79–96.
- Driscoll, S T & Yeoman, P 1997 *Excavations within Edinburgh Castle in 1988–1991*. Edinburgh: Society of Antiquaries of Scotland.
- Duco, D 1987 *De Nederlandse Kleipijp: handboek voor dateren en determineren*, Leiden: Pijpenkabinet.
- Edinburgh Corporation 1926 *Edinburgh Corporation Gas Undertaking – Granton Works: Inauguration of New Vertical Retort Plant by HRH the Duke of York 9.10.1926*. Commemorative brochure.
- Edinburgh Magazine and Literary Miscellany 1824 'Documents in the coal and oil gas controversy', *The Edinburgh Magazine and Literary Miscellany* 94: 736–44.

- Edinburgh Observer 1817 'History and progress of the application of gas from pit-coal to economical purposes', *The Edinburgh Observer*, I (Saturday 13 September 1817): 5–6 and II (Saturday 27 September 1817): 27–8.
- Edwards, L 1988 *The Archaeology of the Clay Tobacco Pipe*, XI: *Seventeenth and Eighteenth Century Tyneside Tobacco Pipe Makers and Tobacconists* (series editor P Davey). Oxford: British Archaeological Reports, British Series, 192.
- Engl, R forthcoming *Rich Man, Poor Man: Excavations at the Canongate Poorhouse Site, Calton Road, Edinburgh*.
- Engl, R & Bailey, E 2006 'Caltongate, Edinburgh. Archaeological Evaluation of the North Basement', unpublished archive data structure report, AOC Archaeology Group.
- Engl, R, Bailey, E & Scott, L 2006 'Former New Street Bus Station, City of Edinburgh (Edinburgh parish), archaeological evaluation and watching brief', *Discovery and Excavation in Scotland* (new series) 7: 70.
- Engl, R, Cook, M & Sproat, D 2013 'Caltongate, PA1 (C) Site, Edinburgh Archaeological Evaluation & Excavation: Data Structure Report', unpublished AOC Archaeology report.
- Fitzpatrick, E A 1993 *Soil Microscopy and Micromorphology*. Chichester: John Wiley and Sons.
- Fouracre, L 2007 'Soil micromorphology', in Toolis, R & Sproat, D 'The transformation of an early post-medieval town into a major modern city: excavation and survey of the Waverley Vaults, New Street, Edinburgh, Scotland', *Post-Medieval Archaeology* 41(1) 2007: 155–79.
- Francis, A 2010 *Stepney Gasworks: The Archaeology and History of the Commercial Gas Light and Coke Company's works at Hartford Street, London E1, 1837–1946*, MOLA Archaeology Studies Series 22. London: Museum of London Archaeology.
- Gallagher, D B 1987a 'Edinburgh pipemakers in the seventeenth century: the documentary evidence', in Davey, P J (ed) *The Archaeology of the Clay Tobacco Pipe*, X: *Scotland*, 3–13. Oxford: British Archaeological Reports, British Series, 178.
- Gallagher, D B 1987b 'Tron Kirk', in Davey, P J (ed) *The Archaeology of the Clay Tobacco Pipe*, X: *Scotland*, 269–71. Oxford: British Archaeological Reports, British Series, 178.
- Gallagher, D B 1987c 'Thomas White, tobacco pipe manufacturer of Canongate, Edinburgh', in Davey, P J (ed), *The Archaeology of the Clay Tobacco Pipe*, X: *Scotland*, 25–8. Oxford: British Archaeological Reports, British Series, 178.
- Gallagher, D B 1989 'TW pipes: their origins and development', *Society for Clay Pipe Research Newsletter* 22: 1–7.
- Gallagher, D B 1996 'Clay tobacco pipes', in Lewis, J 'Dunstaffnage Castle, Argyll & Bute: excavations in the north tower and east range, 1987–94', *Proc Soc Antiq Scot* 126: 590–6.
- Gallagher, D B 1997 'Clay pipes', in Driscoll, S T & Yeoman, P A *Excavations within Edinburgh Castle in 1988–91*, 178–83. Edinburgh: Society of Antiquaries of Scotland.
- Gallagher, D 2008 *Stirling Castle Palace, Archaeological and Historical Research 2004–2008: Analysis of Clay Tobacco Pipe Fragments*. Edinburgh: Kirkdale Archaeology/Historic Scotland. <https://webarchive.nrsotland.gov.uk/web/20180403091949/http://sparc.scran.ac.uk/publications/level%20II/level2PublicationsMajor.html>. Accessed 27 September 2022.
- Gallagher, D B 2010 'Clay tobacco pipes', in Barclay, G J & Ritchie, A 'Artefactual, environmental and archaeological evidence from the Holyrood Parliament Site excavations', *Scottish Archaeological Internet Reports* 40: 53–9. <https://doi.org/10.5284/1017938>.
- Gallagher, D B 2013 'Clay tobacco pipes', in Gooder, J 'Excavations in the Canongate backlands, Edinburgh', *Scottish Archaeological Internet Reports*, 56: 21–6. <https://doi.org/10.9750/issn.1773-3808.2013.56>.
- Gallagher, D 2015 'Clay tobacco pipes', in Ewart, G & Gallagher, D *With Thy Towers High: The Archaeology of Stirling Castle and Palace*, 238–45. Edinburgh: Historic Scotland.
- Gallagher, D 2017 'Clay tobacco pipes', in Engl, R 'Where there's muck there's money: the excavation of medieval and post-medieval middens and associated tenement at Advocate's Close, Edinburgh', *Scottish Archaeological Internet Reports* 67: 43–6. <https://doi.org/10.9750/issn.2056-7421.2017.67>.
- Gooder, J 2000 'Calton Road Gasworks, City of Edinburgh (City parish of Edinburgh), medieval/

- post-medieval cultivation soil', *Discovery and Excavation in Scotland* (new series) 1: 32.
- Grant, A 1982 'The use of tooth wear as a guide to the age of domestic ungulates', in Grigson, C, Wilson, R & Payne, S (eds), *Ageing and Sexing Animal Bones*, 91–108. Oxford: British Archaeological Reports, British Series, 109.
- Grant, J 1883 *Old and New Edinburgh*, vol 3. London: Cassell, Petter, Galpin & Co. <https://www.oldandnewedinburgh.co.uk/volume3/>. Accessed 24 November 2017.
- Groome, F H 1884 *Ordnance Gazetteer of Scotland: A Survey of Scottish Topography*. <https://digital.nls.uk/gazetteers-of-scotland-1803-1901/archive/97372786>. Accessed 11 December 2017.
- Haggarty, G & Grey, J A 2013 'Glasgow and the Delftfield pottery: new ceramic evidence', *English Ceramic Circle Transactions* 21: 105–18.
- Haggarty, G & Hall, D forthcoming 'Excavated Italian pottery in Scotland'.
- Haggarty, G R & Hughes M, 2013 'The medieval and later pottery from Niddrie near Edinburgh', *Medieval Ceramics* 33: 54–71.
- Haggarty, G & Lawson, J A 2013a 'Clay pipe and tile report', in Cook, M, Cross, M & Lawson, J A 'Marlin's Wynd: new archaeological and documentary research on post-medieval settlement below the Tron Kirk, Edinburgh', *Scottish Archaeological Internet Reports* 55: 29. <https://doi.org/10.9750/issn.1773-3808.2013.55>.
- Haggarty, G & Lawson, J A 2013b 'The pottery assemblage', in Cook, M, Cross, M & Lawson, J A 'Marlin's Wynd: new archaeological and documentary research on post-medieval settlement below the Tron Kirk, Edinburgh', *Scottish Archaeological Internet Reports* 55: 17–29. <https://doi.org/10.9750/issn.1773-3808.2013.55>.
- Haggarty, G, Hall, D & Chenery, S 2011 'Sourcing Scottish redwares' *Medieval Pottery Research Group*, Occasional Paper 5.
- Hathaway, A W 2012 *Remediation of Former Manufactured Gas Plants and Other Coal-Tar Sites*. Boca Raton: Taylor & Francis Group.
- Hayward, P J, Nelson-Smith, T & Shields, C 1996 *Seashore of Britain & Northern Europe*. Oxford: HarperCollins.
- Herring, W R 1903 *Edinburgh and Leith Corporation's Gas Commissioners Granton Works*. Descriptive pamphlet.
- Herring, W R c 1906 *Edinburgh and Leith Corporation's Gas Commissioners Granton Works Descriptive Pamphlet*. Pamphlet.
- Herring, W R 1907 *The Granton Works of the Edinburgh and Leith Gas Commissioners: Their Design, Construction and Equipment*. London: Walter King.
- Hide, K 2010 'Profession versus trade? A Defining Episode in the Gas Lighting Industry in the Late 19th Century', unpublished MA dissertation, University of London. https://sas-space.sas.ac.uk/2816/1/Hide_-_Gas_Lighting_-_MA_2010.pdf. Accessed 4 December 2017.
- Hillson, S 1986 *Teeth*. Cambridge: Cambridge University Press.
- Historic Environment Scotland 2017 *Biggar Gasworks Official Visitor's Guide*.
- Holmes, N 1987 'Huntly House Museum (Edinburgh parish) medieval pit', *Discovery and Excavation in Scotland* 1987: 30.
- Holmes, N 1988 'Canongate Tolbooth, cellar of Tolbooth prison', *Discovery and Excavation in Scotland* 1988: 18.
- Hornby, J 1911 *A Text-Book of Gas Manufacture for Students*. London: G Bell & Sons Ltd.
- Hunt, C 1907 *A History of the Introduction of Gas Lighting*. London: Walter King/Office of the Journal of Gas Lighting.
- Jones, E & Holden, T 2003 '22 Calton Road (City parish of Edinburgh), standing building recording; excavation', *Discovery and Excavation in Scotland* (new series) 4: 68.
- Jongerius, A 1983 'The role of micromorphology in agricultural research', in Bullock, P (ed) *Soil Micromorphology*, 111–38. Berkhamstead: AB Academic Press.
- Karkanias, P & Goldberg, P 2007 'Micromorphology of sediments: deciphering archaeological context', *Israel Journal of Earth Sciences* 56: 63–71.
- Knox, W W 2014 *A History of the Scottish People: Transport and Scottish Society 1840–1940*. https://www.scran.ac.uk/scotland/pdf/SP2_9transport.pdf. Accessed 13 December 2017.
- Ladies' Treasury 1859 'On dits of the month', *The Ladies' Treasury* (Thursday 1 September 1859): 287.
- Laing, D 1859 'Proposals for Cleaning and Lighting

- the City of Edinburgh (with original signatures of a number of the principal inhabitants), in the year 1735', *Proc Soc Antiq Scot* 3 (1857–9): 171–80.
- Lowther, J 2018 'The excavation of a medieval burgh ditch at East Market Street, Edinburgh: around the town', *Scottish Archaeological Internet Reports* 78. <https://doi.org/10.9750/issn.2056-7421.2018.78>.
- McCullagh, R & Gooder, J 1999 'Calton Road Gasworks (City parish of Edinburgh), watching brief', *Discovery and Excavation in Scotland* 1999: 35.
- Macdonald, G 1924 'Roman coins found in Scotland. II', *Proc Soc Antiq Scot* 58 (1923–4): 325–9.
- McDowall, T & McDowall, W 1842 *McDowall's New Guide in Edinburgh*. Edinburgh: Thomas and William McDowall.
- McGowan, J 2012 *Policing the Metropolis of Scotland: A History of the Police and Systems of Police in Edinburgh and Edinburghshire: 1770–1833*. Musselburgh: Turlough Publishers.
- MacKay, J 1879 *History of the Burgh of Canongate*. Edinburgh: Seton & Mackenzie.
- MacKenzie, W S & Adams, A E 1994 *A Colour Atlas of Rocks and Minerals in Thin Section*. London: Manson.
- MacKenzie, W S & Guilford, C 1980 *Atlas of Rock-Forming Minerals in Thin Section*. London: Longman.
- McLaren, D forthcoming 'The refractory ceramic', in Hindmarch, E & Roy, M 'Excavations at Salamander Place, Leith'.
- Madill, W D 2013 'Noiseless, Automatic Service: The History of Domestic Servant Call Systems in Charlestown South Carolina, 1740–1900', unpublished Masters thesis, Clemson University and College of Charleston.
- Martin, C 2017 *A Cromwellian Warship Wrecked off Duart Castle, Mull, Scotland, in 1653*. Edinburgh: Society of Antiquaries of Scotland.
- Masser, P, Kimber, M, Franklin, J, Cross, M & Tourunen, A 2014 'Excavations at Jeffrey Street, Edinburgh: the development of closes and tenements north of the Royal Mile during the 16th–18th centuries', *Scottish Archaeological Internet Reports* 58. <https://doi.org/10.9750/issn.1773-3808.2014.58>.
- Matthews, W, French, C A I, Lawrence, T, Cutler, D F & Jones, M K 1997 'Microstratigraphic traces of site formation processes and human activities', *Journal of World Archaeology* 29: 281–308.
- Murray, S 1996 *The Edinburgh Encyclopedia*. Edinburgh: Mainstream Publishing.
- Murdoch, R 2008 'Glass', in Oleksy, V 'Conformity and resistance in the Victorian penal system: archaeological investigations at Parliament House, Edinburgh', *Post-Medieval Archaeology* 42(2): 287–8.
- Murdoch, K R 2011 'The glass', in Bailey, A S, Barton, T, Bowler, D, Gallagher, D, Haggarty, G, Hall, D, Murdoch, K R & Smith, C 'Excavations at Alloa Tower, Clackmannanshire, 1988–1993', *Tayside and Fife Archaeological Journal* 17: 68–113.
- Murphy, C P 1986 *Thin Section Preparation of Soils and Sediments*. Berkhamsted: AB Academic Press.
- NSA 1845 *The New Statistical Account of Scotland*, vol 1: *Edinburghshire*, 'City of Edinburgh', 614–759.
- Paton, H 1902 *Register of interments in the Greyfriars burying-ground, Edinburgh 1658–1700*. Edinburgh: Scottish Record Society.
- Payne, S 1973 'Kill-off patterns in sheep/goat and goats: the mandibles from Aşvan Kale', *Anatolian Studies* 23: 281–303.
- Payne, S 1987 'Reference codes for wear states in the mandibular cheek teeth of sheep and goats', *Journal of Archaeological Science* 14: 609–14.
- Pearson, L 2016 *Victorian and Edwardian British Industrial Architecture*. Ramsbury: The Crowood Press.
- Peebles, M W H 1980 *Evolution of the Gas Industry*. London and Basingstoke: Macmillan.
- Robertson, J 2017 'Appendix 6: The animal bone assemblage', in Engl, R 'Where there's muck there's money: the excavation of medieval and post-medieval middens and associated tenement at Advocate's Close, Edinburgh', *Scottish Archaeological Internet Reports* 67: 48–53. <https://doi.org/10.9750/issn.2056-7421.2017.67>.
- Robertson, J 2018 'Appendix 7: The animal bone', in Lowther, J 'The excavation of a medieval burgh ditch at East Market Street, Edinburgh: around the town', *Scottish Archaeological*

- Internet Reports 78. <https://doi.org/10.9750/issn.2056-7421.2018.78>.
- Roy, L 2018 'Caltongate North: Micromorphological Analysis Report AOC 20974', unpublished AOC Archaeology report.
- Russell, C A 1973 'Coal, the basis of nineteenth century technology', in *Science and the Rise of Technology since 1800, Block II Unit 4*. Bletchley: Open University Press.
- Satirist 1849 'Scotland: destructive explosion', *The Satirist or the True Censor of the Times*, issue 880 (3 February 1849): 52.
- Schmid, E 1972 *Atlas of Animal Bones*. London: Elsevier.
- Schweingruber, F 1978 *Microscopic Wood Anatomy*. Birmensdorf: Swiss Federal Institute for Foreign Research.
- Scottish Gas Board 1960 *Granton Works*.
- Shakhmatova, K, Chuchra, K J & Francey, S 2012 *A History of Street Lighting in the Old and New Towns of Edinburgh World Heritage Site*. <https://ewh.org.uk/wp-content/uploads/2017/09/Lighting-project-publication-ver-6-Feb-2012.pdf>. Accessed 23 November 2017.
- Silver, I 1969 'The ageing of domestic animals', in Brothwell, D & Higgs, E (eds), *Science in Archaeology* vol 2, 283–302. London: Thames & Hudson.
- Simpson, A T, Stevenson, S & Holmes, N 1981 *Historic Edinburgh, Canongate and Leith: The Archaeological Implications of Development*. Glasgow: Scottish Burgh Survey series.
- Skempton, A W, Chrimes, M M, Cox, R C, Cross-Rudkin, P S M, Rennison, R W & Ruddock, E C 2002 *A Biographical Dictionary of Civil Engineers in Great Britain and Ireland*, vol 1: 1500–1830. London: Thomas Telford Publishing.
- SODD 1999 *National Planning Policy Guideline 18: Planning and the Historic Environment*. Scottish Office Development Department.
- SOEnD 1994a *National Planning Policy Guideline 5: Archaeology and Planning*. Scottish Office Environment Department.
- SOEnD 1994b *Planning Advice Note 42: Archaeology and Planning*. Scottish Office Environment Department.
- Sproat, D 2006 'The history of Granton Gasworks', *Industrial Archaeology Review* 38(1): 33–46.
- Sproat, D 2008 'Caltongate PA1(A) & PA1(B), Edinburgh Historic Building Recording Data Structure Report', unpublished AOC Archaeology report.
- Sproat, D & Toolis, R 2008 'Caltongate PA1 (A) & PA1 (B), Edinburgh Historic Building Recording Data Structure Report', unpublished AOC Archaeology report.
- Stark, J 1834 *Picture of Edinburgh: Containing a Description of the City and its Environs*, 6th edition. Edinburgh: John Anderson, A. & C. Black and William Hunter.
- Stoops, G 2003 *Guidelines for Analysis and Description of Soil and Regolith Thin Sections*. Madison, WI: Soil Science Society of America.
- Taylor, M 1851 'A detailed description of the above chimney. By M Taylor Esq, Engineer for the Edinburgh Gas Works', in 'High chimneys: an account of the high chimney of the Edinburgh Gas Works with observations on the principles of its strength and stability. By George Buchanan Esq, FRSE, Civil Engineer (Paper read at the Royal Scottish Society of Arts)', *The Civil Engineer and Architect's Journal* 14: 34–5.
- Thomas, C 1996 'The leather', in Emery, N *Excavations on Hirta, 1986–90*, 165–7. Edinburgh: NTS/HMSO.
- Thomas, R 2014a *Gasworks Profile A: The History and Operation of Gasworks (Manufactured Gas Plants) in Britain*. London: Contaminated Land: Applications in Real Environments (CL:AIRE).
- Thomas, R 2014b *Gasworks Profile C: Water Gas Plants*. London: Contaminated Land: Applications in Real Environments (CL:AIRE).
- Thomas, R 2020a *The Manufactured Gas Industry*, vol 1: *History*. Historic England Research Report Series 182-2000. Portsmouth: Historic England/WSP.
- Thomas, R 2020b *The Manufactured Gas Industry*, vol 2: *Gasworks*. Historic England Research Report Series 182-2000. Portsmouth: Historic England/WSP.
- Thorsheim, P 2006 *Inventing Pollution: Coal, Smoke and Culture in Britain since 1800*. Athens OH: Ohio University Press.
- Trickett, P 2005 'Caltongate Bus Depot, New Street, Edinburgh: Historic Building Recording Data Structure Report', unpublished AOC Archaeology report.

- Walker, I C 1983 'Nineteenth-century clay tobacco pipes in Canada', in Davey, P (ed), *The Archaeology of the Clay Tobacco Pipe*, VIII: *America*, 1–87. Oxford: British Archaeological Reports, International Series, 175.
- Webber, W H Y 1918 *Gas and Gas Making*. Pitman's Common Commodities and Industries Series. London: Sir Isaac Pitman & Sons.
- Williams, T I 1981 *A History of the British Gas Industry*. Oxford: Oxford University Press.
- Wilmott, H 2017 'The glass', in Engl, R 'Where there's muck there's money: the excavation of medieval and post-medieval middens and associated tenement at Advocate's Close, Edinburgh', *Scottish Archaeological Internet Reports* 67: 35–7. <https://doi.org/10.9750/issn.2056-7421.2017.67>.
- Wilson, D 2007 'Edinburgh Gasworks, Caltongate, City of Edinburgh (Edinburgh parish), watching brief', *Discovery and Excavation in Scotland* (new series) 8: 84.
- Wilson, D 2008a *Caltongate North Watching Brief and Excavation Report*. Edinburgh: AOC Archaeology Group.
- Wilson, D 2008b 'Caltongate PA1(A), Archaeological Evaluation Data Structure Report', unpublished AOC Archaeology report.
- Wilson, D 2008c 'Caltongate PA1(B), Edinburgh Archaeological Excavation Data Structure Report', unpublished AOC Archaeology report.
- Wilson, D 2008d 'Caltongate PA1(C), City of Edinburgh (Edinburgh parish), watching brief', *Discovery and Excavation in Scotland* (new series) 9: 69.
- Wilson, D 2008e 'Caltongate, Edinburgh, Edinburgh Gasworks Archaeological Excavation Data Structure Report', unpublished AOC Archaeology report.
- Wilson, D 2008f 'Caltongate North, City of Edinburgh (Edinburgh parish), watching brief and excavation', *Discovery and Excavation in Scotland* (new series) 9: 68–9.
- Wilson, D 2012 'Sugarhouse Close, 160 Canongate, Edinburgh: Archaeological Works', unpublished Headland Archaeology report.
- Wilson, D & Toolis, R 2008a 'Caltongate North, Edinburgh Watching Brief & Excavation-Data Structure Report', unpublished grey literature report.
- Wilson, D & Toolis, R 2008b 'Caltongate PA1(A), Edinburgh Archaeological Evaluation-Data Structure Report', unpublished grey literature report.
- Wood, J 1982 *Early Gas Making*. Edinburgh: Royal Scottish Museum.