

## CHAPTER 15

### Medieval and post-medieval metalwork

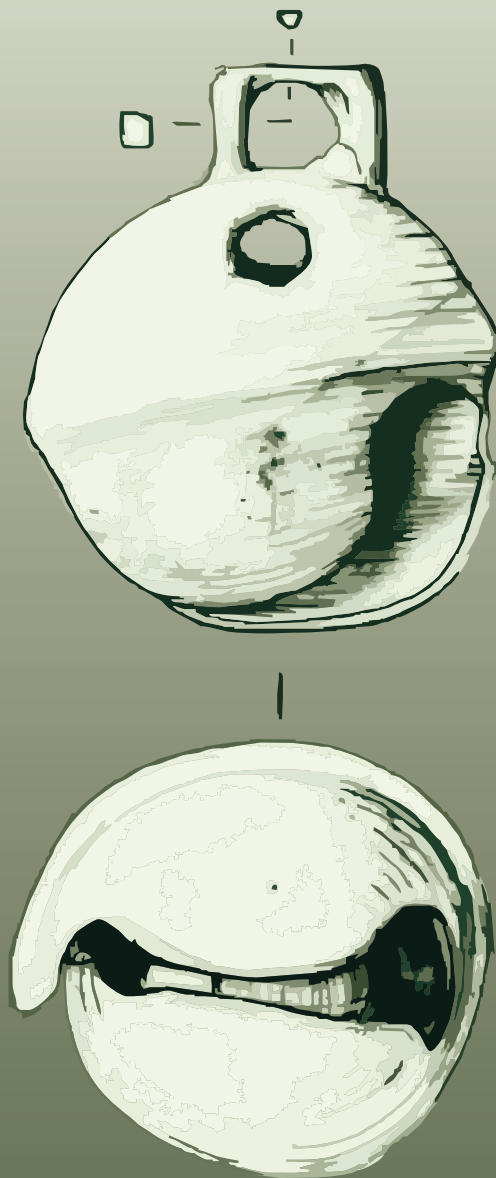

*by Leigh Allen*

## **15 Medieval and post-medieval metalwork**

*Leigh Allen*

A total of 1,042 post-Roman metal objects was recovered from the excavations carried out at Stansted Airport. The bulk of the assemblage is post-medieval in date and was recovered from the final phase of work carried out on the LTCP site in 2001 (containing the hunting lodge). However smaller assemblages were recovered during the earlier phases of work at the LTCP (BAACP99 and BAACP00) and also from the MTCP (BAAMP99 and BAAMP00), FLB (BAAFL00) and the LBR (BAAFL00) sites.

The assemblage comprises 166 copper alloy objects (excluding coins), 856 iron objects (including 653 nails) and 21 lead objects. Table 15.1 indicates the number of objects of each metal type from each of the sites.

This report deals only with the identifiable objects; a full list including all the miscellaneous fragments and unclassified objects will be deposited with the archive. The metalwork assemblage has been divided into the following functional categories; personal accessories, domestic items, lock furniture, knives, tools, horsegear, objects associated with hunting and structural objects (including nails). The first section of this report is a catalogue of the identifiable objects recovered from all phases of work at Stansted Airport and is ordered by function the second section discusses the artefacts by site and phase.

### **Section 1 - Catalogue**

#### *Personal Accessories*

##### **Lace tags** (Fig. 15.1, nos 1-3)

A total of 24 lace tags were recovered from LTCP site (BAACP01). All are formed from rolled sheet copper alloy. Three types have been recovered from Stansted; one of each type has been illustrated. The typology used here follows Oakley (Oakley and Webster 1979, 262-3) and Margeson (Margeson 1993, 22). The first type tapers slightly and has edges that overlap along its length (Margeson type 3), the second type also tapers but has edges that meet at the upper end and then overlap at the tip (Oakley type 1 dating mainly to the 15th century with some of 16th and 17th century date), both of these two types of tag have holes at the top for thread or a rivet to attach it to the lace or ribbon. The third type has edges that meet but then turn in on themselves and does not require sewing or a rivet to attach it (Oakley type 2 dating from the mid 16th to 17th centuries). Lace tags are a common find in post-medieval contexts as the fashion for tighter fitting garments in the late medieval to post-medieval periods would have produced a great demand for laces (Egan and Pritchard 1991, 284).

1. (illus.) Lace tag with a slight taper. The edges meet at the upper end but overlap at the tip, and there is a rivet/thread hole at the top (Oakley type 1). BAACP01, SF 1283, ctx 480065, length 23 mm.
2. (illus.) Lace tag tapering and with edges that meet and then turn in on themselves to secure the tag to the lace (Oakley type 2). BAACP01, SF 1259, ctx 448001, length 27 mm
3. (illus.) Lace tag with a slight taper and edges that overlap and a rivet/thread hole at the top (Margeson type 3). BAACP01, SF 1271, ctx 448002, length 30 mm

### **Pins** (Fig. 15.1, nos 4-6)

A total of 64 pins were recovered from the LTCP site (BAACP01). Three types of pin have been recovered from Stansted and one of each type has been illustrated. Type 1 has a wire wound head, the coils of the head are distinct, type 2 has a spherical head where the coils are present but indistinct and type 3 is a large more robust pin with a cast spherical head. Pins are a common find in post-medieval contexts and are often found in association with large numbers of lace tags.

4. (illus.) Pin with a wire spiral wound head; the coils of the spiral are distinct BAACP01, SF 1370, ctx 459027, length 28 mm.
5. (illus.) Pin with a spherical wire wound head the coils of the spiral are indistinct BAACP01, SF-, ctx 447011, length 34 mm
6. (illus.) Large pin with cast spherical head BAACP01, SF 1210, ctx 480068, length 47 mm

### **Wire loop fasteners** (Fig. 15.1, no. 7)

Six wire loop fasteners were recovered from the LTCP site (BAACP01). Simple loops of fine wire with the ends twisted around each other are commonly found in large numbers in medieval and post-medieval contexts. Often associated with assemblages of pins and lace tags, they were used to fasten garments (Margeson 1993, 20, fig.10, no.101). All six examples from Stansted are identical; one example has been illustrated.

7. (illus.) Wire loop fastener with the ends twisted around each other. BAACP01, SF 1275, ctx 448001, length 11 mm.

### **Hook and eye fastener** (Fig. 15.1, no. 8)

A single s-shaped fragment from the hook of a hook and eye fastener was recovered from LTCP site (BAACP01). This type of fastening was commonly used in the late medieval and post-medieval period.

8. (illus.) A fragment from the hook of a hook and eye fastener BAACP01, SF 1158, ctx 448001, length 17 mm.

### **Hooked clasp** (Fig. 15.1, no. 9)

The remains of a hooked clasp with a composite sleeve and internal spring was recovered from the LTCP site (BAACP01). Hooked clasps were probably used to join decorative accessories together or onto a garment or strap. This particular design of clasp with its decorated sleeve and simple internal spring dates to the late 15th century (Egan 2005, 44-45, fig. 26 no.160).

9. (illus.) Hooked clasp, the back plate has a roughly cut rectangular flap, which has been folded back internally to form a spring. The curved front sheet is decorated with an openwork lattice design, the hook end is broken off. BAACP01, SF 1156, ctx 480010, length 30 mm.

### **Buttons** (Fig. 15.1, nos 10-13)

A total of seven buttons were recovered from the LTCP site (BAACP01). Three types of button were identified; all of post-medieval date; one of each type has been illustrated. The most common type is the plain circular, discoidal button with an integral attachment loop; there are five examples of this type. Three have a wire loop attachment (Biddle and Cook 1990, 578, fig. 155, no.1760) and the other two have a short rectangular shank with a perforation through it (Biddle and Cook 1990, 578, fig. 155, no.1752). Two examples have a coating of tin on the upper surface. The remaining two buttons are a circular dished button with four holes at the centre for attachment, and a two-piece button consisting of a copper sheet metal cover over an iron back. The upper face has an embossed decoration on it.

10. (illus.) Plain, circular discoidal button with an integral wire attachment loop BAACP01, SF-, ctx 449017, diameter 31 mm
11. (illus.) Plain, circular, discoidal button with a rectangular perforated shank BAACP01, SF -, ctx 449018, diameter 14 mm
12. (illus.) Dished button with a rounded rim and 4 holes at the centre for attachment BAACP01, SF 1197, ctx 448001, length 16 mm.
13. (illus.) Two piece button with a copper alloy sheet metal cover over an iron back, the means of attachment is missing. The upper face is decorated with an embossed design, possibly a thistle. BAACP01, SF 1236, ctx 448001, diameter 15 mm

**Buckles** (Fig. 15.1, nos 14-43)

A total of 32 buckles (and buckle parts) were recovered, 29 came from the LTCP site (BAACP01), 1 from the MTCP site and 2 from the FLB site. A variety of buckle forms are present, ranging from simple utilitarian circular, oval, rectangular, and D-shaped frames through to more ornate double-oval frames. The larger iron buckles particularly the examples with trapezoidal-shaped frames and sheet metal rollers are probably for use with horse's harness. There is a single example of a buckle with an oval frame and a composite rigid plate (Cat. No.39) of mid 14th to early 15th century date (Egan and Pritchard 1991, 78-82, fig 48 and 49) and a rectangular locking buckle of late medieval date (Egan and Pritchard 1991, 97, fig 62, no.445).

14. (illus.) Small annular buckle frame with pin BAACP01, SF 1185, ctx 480039, iron, length 13 mm
15. (illus.) Oval frame with narrow offset bar, the pin is missing BAAFL00, SF 243, ctx 402019, copper alloy, length 33 mm
- 16-17. Rectangular buckle frame with pin (found corroded to SF 1192b)  
BAACP01, SF 1192a, ctx 448001, iron, length 46 mm (illus.)  
BAACP01, SF 1303, ctx 480053, iron, length 36 mm
18. (illus.) Rectangular buckle frame with central bar, the bar is waisted slightly at the centre where it has been worn by the pin. BAACP01, SF -, ctx 449018, iron, length 34 mm
19. (illus.) Rectangular buckle frame the bar is slightly recessed and there is a notch for the pin rest BAACP01, SF -, ctx 449017, copper alloy, length 35 mm
20. (illus.) A cast rectangular buckle frame with pin. The frame has a flattened hexagonal section, 14th -15th century in date (Williams 1978, fig 22.10 and Margeson 1993, 28, fig 14, no.145). BAACP01, SF 1232, ctx 472004, copper alloy, length 32 mm
- 21-26. D-shaped buckle frame with pin  
BAACP01, SF-, ctx 459008, iron, length 39 mm (illus)  
BAACP01, SF 1167, ctx 448001, iron, length 41 mm  
BAACP01, SF 1192b, ctx 448001, iron, length 32 mm(corroded to SF 1192a)  
BAACP01, SF 1178, ctx 480034, iron, length 25 mm  
BAACP01, SF 1163, ctx 448001, iron, length 32 mm  
(illus.) BAACP01, SF 1267, ctx 448001, copper alloy, length 14 mm
27. (illus.) A D-shaped buckle frame with an arched bar (pin missing) BAACP01, SF -, ctx 449018, copper alloy, length 30 mm
- 28-29. Elongated D-shaped buckle frame with pin  
BAACP01, SF 1339, ctx 458024, copper alloy, length 58 mm  
(illus) BAACP01, SF-, ctx 465029, iron, length 59 mm (pin missing)
30. A double D-shaped buckle frame BAACP01, SF 1187, ctx 448001, iron, length 25 mm

31. (illus.) Trapezoidal buckle frame with pin BAACP01, SF 1402, ctx 472003, iron, length 43 mm
32. (illus.) Trapezoidal buckle frame with sheet roller and pin BAACP01, SF 1395, ctx ?, iron, length 52 mm
33. (illus.) A simple cast double-oval buckle frame with slightly expanded pin rests. Iron corrosion around the central bar is all that remains of the pin. BAACP01, SF 1202, ctx 448001, copper alloy, length 33 mm
34. (illus.) A cast double-oval buckle frame with expanded pin rests and lobes at the junction of the bar and frame. The pin rests are decorated with raised bobbles in the form of a flower. A similar example from Norwich was recovered from an early 17th century context (Margeson 1993, 28, fig.17, no.174) BAACP01, SF 1407, ctx 452015, copper alloy, length 40 mm
35. (illus.) A cast double-oval buckle frame with 4 knops, one at each corner and lobes at the junction of the bar and frame. Iron corrosion around the central bar is all that remains of the pin. Late 16th-17th century in date (Zeepvat 1992, 142, Fig.53, no.39). There are fine grooves/scratches on both faces, which are probably casting flashes from the manufacturing process. BAACP01, SF 1207, ctx 472004, copper alloy, length 39 mm)
36. (illus.) A cast double-oval buckle frame with lobes at the junction of the bar and frame. The outside edge decorated with a fluted design. BAACP01,SF 1152, ctx 448001, copper alloy, length 28 mm
37. (illus.) A cast double-oval buckle frame with a folded plate around the central bar. The plate is recessed for the pin and has two rivets for attachment to the strap. BAACP01, SF 1211, ctx 480073, copper alloy, length 39 mm
38. (illus.) Fragment from a cast double oval buckle frame with a D-shaped section. BAACP01, SF -, ctx 449017, copper alloy, length 28 mm
39. Buckle with an oval frame and composite rigid plate. The plates are missing from this example and only part of the forked spacer survives. The frame is lipped and bevelled, the bar is off set and constricted for the pin. BAAFL00, SF 253, ctx 401013, copper alloy, length 35 mm
40. (illus) A locking buckle with a rectangular frame with an off centre combined bar and pin. The holes for the bar are flanged for extra strength and there is a groove in the outside edge by which the arm was held closed. BAACP01, 1233, ctx 472004, copper alloy, length 28 mm
41. (illus.) Figure-of-eight shape buckle frame BAACP01, SF 1214, ctx 448001, iron, length 40 mm
42. (illus.) A folded sheet metal buckle plate recessed for the buckle pin. There are 3 possibly 4 perforations through the plate for rivets. BAAMP00, SF 967, context 301001, copper alloy, length 23 mm
43. (illus.) Folded sheet metal buckle plate, recessed for the pin and with 2 rivets to secure the plate to the strap. BAACP01, SF -, ctx 448001, copper alloy, length 27 mm
44. Large buckle pin, that curves up at the tip to fit over the frame BAACP01, SF -, ctx 461001, iron, length 68 mm
45. Curved fragment from a possible buckle frame with a lobed outside edge, the x-ray indicates that the buckle has been plated probably with tin. BAACP01, SF 301, ctx 307015, iron, length 24 mm

#### **Annular brooch/buckle frame (Fig. 15.1, no. 46)**

A decorated annular brooch/buckle frame was recovered from the FLB site (context 401013). Buckle frames can usually be distinguished from brooches by the presence of a constriction for the pin, unfortunately this object is broken exactly where the constriction might have been. The frame has areas of cable decoration between which the frame is plain. A similar object recovered from London with identical decoration has been classified as a brooch (Egan and Pritchard 1991, 248-250, fig.160, no.1315).

46. An annular brooch/buckle frame decorated with a cable design, the frame is incomplete. BAAFL00, SF 245, ctx 401013, copper alloy, length 27 mm

#### **Mounts** (Fig. 15.2, nos 47-54)

A total of 8 mounts were recovered from the LTCP site (BAACP01). The majority of them are circular, plain domed sheet metal mounts with separate rivets. They would have been used probably in combination with other mounts to form a decorative effect on girdles and other straps and possibly on purses and shoes (Egan and Pritchard 1991, 162). One large circular mount (Cat. No.52) may, because of its size, have been used on horse harness rather than dress. Also included in this section is a small solid, circular domed mound (Cat. No. 54) that has two integral spikes on the flat back for attachment.

47. (illus.) Circular, plain domed mount with a separate rivet through the centre, the rivet is incomplete BAACP01, SF 1255, ctx 448001, copper alloy, length 10 mm
48. (illus.) Circular, plain domed mount with a perforation through the centre, the rivet is missing BAACP01, SF 1295, ctx 480062, copper alloy, length 9 mm
49. A very corroded circular plain domed mount with a perforation through the centre BAACP01, SF 1184, ctx 448001, copper alloy, length 11 mm
50. (illus.) Circular, plain domed mount with a separate rivet through the centre. BAACP01, SF 1175, ctx 480034, copper alloy, length 13 mm
51. (illus.) Circular, plain domed mount with a perforation through the centre, the top of the mount is slightly dished and the rivet is missing. BAACP01, SF 1201, ctx 448001, copper alloy, length 17 mm
52. (illus.) A large circular disc-shaped mount with a worn perforation at the centre and 2 smaller perforations at the edge. BAACP01, SF 1208, ctx 480047, copper alloy, length 52 mm
53. (illus.) Fragment from a cinquefoil mount in the form of a flower with raised decoration on each of the petals and perforation through the centre. The mount has been plated with tin. BAACP01, SF 1190, ctx 448001, copper alloy, length 13 mm
54. (illus.) A solid circular domed mount with 2 integral spikes on the flat back for attachment. Both the spikes are bent almost at 90 degrees. BAACP01, SF 1298, ctx 480053, copper alloy, length 10 mm

#### **Rings**

Only three rings were recovered from the excavations one from the FLB site and the other two from the LTCP site (BAACP01). The rings are very crudely made only Cat. No.55 from context 401013 looks, (from its size), to be a possible finger ring, although it could be a suspension ring.

55. A plain ring with a diamond-shaped section BAAFL 01, SF 252, ctx 401013, copper alloy, length 23 mm
56. Two crude rings with circular sections joined at their outside edges by a strip that has been wrapped around them. BAACP01, SF 1252, ctx 472004, iron, length 61 mm

#### **Bells** (Fig. 15.2, nos 57-60)

A complete cast crotal, a fragment from a second and two fragments from pellet bells were recovered from the LTCP site (BAACP01). Crotals would have been used on harness; the smaller pellet bells could have been used to decorate dress or harness. Bells are a common find in the later medieval and post-medieval periods (Biddle and Hinton 1990, 726).

57. (illus.) An undecorated cast crotal with a rectangular suspension loop, the iron pellet survives inside (Zeepvat 1992, 170, fig 80, and no. 211). BAACP01, SF -, ctx 448001, copper alloy, length 35 mm

58. (illus.) The upper half of a sheet metal pellet bell with a strap loop for suspension; there are traces of solder around the edges where the upper hemisphere would have been joined to the lower BAACP01, SF 1263, ctx 448001, copper alloy, length 20 mm
59. (illus.) Cast fragment from a hemispherical object possibly the upper or lower sections of a crotal decorated with incised radiating grooves BAACP01, SF -, ctx 448001, copper alloy, length 24 mm
60. (illus.) A hollow sheet metal hemisphere, possibly the lower half of a pellet bell BAACP01, SF 1244, context 448002, copper alloy, length 21 mm

**Patten** (Fig. 15.2, no. 61)

A single patten fitting was recovered from the LTCP site. Pattens were used as an overshoe in wet and muddy conditions and consisted of a wooden sole beneath which projected an iron framework. This patten has a ring with 2 angled brackets to attach it to the wooden sole. A similar example recovered from Gt. Linford (Zeepvat 1992, 150-151) is dated to the 17th century.

61. (illus.) A patten fitting with a ring and two angled brackets that terminate in flat plates. One plate has a single rivet through it; the other has 2 rivets. BAACP01, SF 1410, ctx 447004, iron, length 209 mm

*Domestic items*

**Sewing equipment** (Fig. 15.2, nos 62-68)

A total of 6 thimbles and a needle were recovered from the LTCP site (BAACP01). Three different forms of thimble are represented. Type 1 is a domed thimble with hand-applied indentations (Cat. No. 62), late medieval in date (Egan and Pritchard 1991, 266-267, fig 206, no.824), type 2 is a straight-sided thimble made in two pieces with machine applied indentations; probably dating to the 17th century (Holmes 1988, 2) and type 3 is made from one piece of sheet metal by the 'deep drawing process' introduced in the 18th century (Holmes 1988, 2).

62. (illus.) A hemispherical thimble with irregular hand applied indentations all over and a small circular perforation through the apex (type 1). BAACP01, SF -, ctx 449017, copper alloy, length 15 mm
- 63-64. (illus.) Straight sided thimble made in two pieces, the cap is a separate (type2). The indentations are machine applied and there is a plain band at the shoulder and the rim.  
BAACP01, SF 1151, ctx 448001, copper alloy, length 21 mm  
BAACP01, SF 1228, ctx 450016, copper alloy, length 22 mm
- 65-66. (illus.) Straight sided thimble made in one piece, the indentations are machine applied. There is a groove at the shoulder and a raised ridge above a plain band at the rim.  
BAACP01, SF 1216, ctx 449026, copper alloy, length 20 mm  
BAACP01, SF -, ctx 449017, copper alloy, length 22 mm
67. (illus.) Straight sided thimble made in one piece with machine applied indentations, the rim of the thimble is turned over, conclusive proof that it was produced by the deep drawing process (type 3). BAACP01, SF -, ctx 449017, copper alloy, length 18 mm
68. (illus.) A large needle with an oval eye, possibly a darning needle BAACP01, SF 1343, ctx 458024, copper alloy, length 55 mm

**Vessels**

Two large fragments and a number of small pieces from cast iron vessels were recovered from the LTCP site (BAACP01). The largest fragment (from an unstratified context) has a full profile surviving and stands to a height of 290 mm (it would have had a diameter of c 410 mm). A single leg with a slightly expanded foot survives and there is a perforated flange on the rim for a handle. The second

fragment is from the base of a vessel also with a single leg with a slightly expanded foot surviving. Such vessels were in use through out the medieval and post-medieval periods, either in an open fire or suspended from a hook above it.

69. Large fragment from a cast metal vessel with a single leg with a slightly expanded foot surviving and a perforated flange at the rim for the handle. BAACP01, SF-, ctx -, iron, height 290 mm, diameter *c* 410 mm
70. Fragment from the base of a cast metal vessel with a single leg with a slightly expanded foot surviving. BAACP01, SF 1406, ctx 462015, iron, length 126 mm
71. Five irregularly shaped cast metal vessel fragments BAACP01, SF-, ctx 461027, iron, length 176 mm

#### **Vessel repairs** (Fig. 15.2, no. 72)

Two paper clip rivets were recovered from the MTCP site. These rivets made from folded sheet metal were used to hold vessel repairs in place (Margeson 1993, 93, fig 59, nos 575-576).

- 72-73. Paper clip rivet made from folded sheet metal  
(illus.) BAAMP00, SF 793, ctx 301001, copper alloy, length 28 mm  
BAAMP00, SF 740, ctx 1006, copper alloy, length 20 mm

#### **Spoon** (Fig. 15.2, no. 74)

An oval bowl from a small spoon was recovered from the LTCP site. There is a raised D-shaped protrusion at one end where the handle would have been attached.

74. (illus.) An oval bowl from a small spoon, There is a raised D-shaped protrusion at one end where the handle would have been attached BAACP01, SF -, ctx 448001, copper alloy, length 35 mm

#### *Lock Furniture*

#### **Keys** (Fig. 15.3, nos 77-78, 80)

A total of eight keys and a barrel padlock bolt were recovered, seven keys came from the LTCP site (BAACP01) and one from the FLB site. The keys are all for mounted locks and have circular, oval or kidney-shaped bows. There are three types of key present. The first has a hollow stem (all examples of this type are fragmentary and therefore no other characteristics are recorded), the second type has a solid stem and a simple bit, the third type has a solid stem that projects beyond the bit and a symmetrically shaped bit incorporating ward cuts that run the depth of the bit. All these forms of key were in use in the late medieval period but only type 3 continued in use into the post-medieval period (Goodall 1990a, 1007).

75. Key for a mounted lock with a circular bow and a hollow stem. The ends of the bow are inserted into the top of the stem and there is a band around the top of the stem. The bit is missing (type 1). BAACP01, SF -, ctx 466010, iron, length 87 mm
76. Key for a mounted lock with a kidney-shaped bow and a hollow stem. The ends of the bow are inserted into the top of the stem and there is a band around the top of the stem. The bit is missing (type 1). BAACP01, SF 1199, ctx -, iron, length 52 mm
77. (illus.) Key for a mounted lock with a circular bow and a hollow stem, the bit is damaged (type 1). BAAFL00, SF 250, ctx 401013, iron, length 101mm
78. (illus.) Key for a mounted lock with a kidney-shaped bow and a solid moulded stem, the bit is incomplete (type 2) BAACP01, SF -, ctx 448001, iron, length 63 mm
79. Key for a mounted lock with an oval bow and a solid stem that projects beyond the end of the simple bit (type 3). BAACP01, SF -, ctx 447004, iron, length 104 mm



80. (illus.) Key for a mounted lock with an oval bow and a solid stem that projects beyond the bit. The bit is symmetrically shaped incorporating ward cuts that run the depth of the bit (type 3). BAACP01, SF1360, ctx 467020, iron, length 138 mm
81. Key for a mounted lock with a kidney-shaped bow and a solid stem that projects beyond the bit. The stem is stepped above the bit and the tip terminates in a rounded knob. The bit is symmetrically shaped incorporating ward cuts that run the depth of the bit (type 3). BAACP01, SF 1281, ctx 480162, iron
82. The broken ward from a key BAACP01, SF 1357, context 467014, iron, length 21 mm

**Padlock bolt** (Fig. 15.3, no. 83)

83. (illus) Barrel padlock bolt with two spines, the double leaf springs are set at right angles to each other BAACP01, SF -, ctx 466010, iron, length 52 mm

*Knives*

**Whittle-tang knives** (Fig. 15.3, nos 84-87, 93-94, 96-100)

The fragmentary remains of 17 whittle-tang knives were recovered, 14 came from the LTCP site (BAACP01), 2 from the MTCP site and 1 from the FLB site. Whittle-tang knives with rod-shaped tangs that were inserted into handles are essentially utilitarian objects and are commonly found in medieval and post-medieval contexts. The earliest example from Stansted dating to the late 13th-14th century was recovered from the FLB site (Cat. No. 84) it has a pronounced triangular blade and a centrally placed tang. There are six examples of knives with bolsters a widening at the junction of the blade and the tang introduced in the 17th century. There are five examples of bone handles, two of which are highly decorated.

84. (illus.) A complete whittle-tang knife with a centrally placed tang and a pronounced triangular-shaped blade, the blade edge is worn through use. Late 13th-late 14th century in date (Cowgill *et al.* 1987, fig 55, no 28 and fig. 60, no. 88). BAAFL00, SF 242, ctx 402019, iron, length 191 mm
85. A very corroded whittle-tang knife the back of the blade and the tang run straight, the blade edge although corroded and worn appears to run parallel to the back of the blade BAACP01, SF 1358, ctx 467014, iron, length 127 mm
- 86-87. Two very fragmentary whittle-tang knives with the tang is centrally placed, and the blade back and edge run parallel for the short length that survives.  
BAACP01, SF 1256, ctx 448001, iron, length 84 mm  
(illus.) BAACP01, SF 1229, ctx 448001, iron, length 96 mm
88. A small whittle-tang knife with a centrally placed tang, the blade back and edge run parallel before they both taper towards the tip. BAACP01, SF -, ctx 480071, iron, length 84 mm
89. A very damaged whittle-tang knife the tang is placed just below the blade back. The blade back and edge run parallel for the short length that survives BAACP01, SF -, ctx 449017, iron, length 97 mm
90. A damaged whittle-tang knife with very little of the tang surviving. The stub of the tang is placed just below the blade back. The blade runs straight and the blade edge runs parallel and then rises towards the tip, the blade edge is very damaged. BAACP01, SF 1273, ctx 448001, iron, length 101 mm
91. A whittle-tang knife with only a short section of the blade surviving, the tang is centrally placed and the back of the blade slopes up towards the break, the blade edge runs straight. There is a copper alloy sheet metal shoulder plate at the junction of the blade and the tang it has 4 decorative ridges that are mirrored in the end cap which is detached. BAAMP00, SF 939, ctx 301001, iron and copper alloy, length 120 mm

92. A whittle-tang knife with a short broad blade, the tang is centrally placed and the blade back rises up and curves down to tip, the blade edge runs straight. There is a copper alloy sheet metal shoulder plate at the junction of the blade and the tang BAAMP00, SF -, ctx 328279, iron and copper alloy, length 117 mm.
93. (illus.) A whittle-tang knife with the tang placed just below the back of the blade. The blade back runs straight; the blade edge curves down and then runs parallel to the back for the short length of the blade that survives. There is a copper alloy shoulder plate at the junction of the blade and the tang. BAACP01, SF 1291, ctx 480072, iron and copper alloy, length 149 mm
94. (illus.) A whittle-tang knife with a centrally placed tang the blade back and edge run parallel before they both taper to the tip. The blade widens slightly at the junction with the tang. Fragments of a plain polished bone handle with a hexagonal section are still attached to the tang. BAACP01, SF 1381, ctx 447012, iron and bone, length 230 mm
95. Very damaged whittle-tang knife with a bolster at the junction of the blade and the tang, the blade does not survive. BAACP01, SF 1213, ctx 448001, iron, length 88 mm
96. (illus.) A whittle-tang knife with an elongated bolster at the junction of the blade and the tang, very little of the blade and the tang survives. This knife has a plain, lightly polished bone handle with a flattened hexagonal section. BAACP01, SF 1401, ctx 466022, iron and bone, length 96 mm
97. (illus.) A whittle-tang knife with a narrow circular bolster at the junction of the blade and the tang. The blade back runs straight but the blade edge angles sharply down. BAACP01, SF 1310, ctx 480091, iron, length 70 mm
98. (illus.) A whittle-tang knife with an elongated tapering bolster at the junction of the blade and the tang, very little of the blade survives. The bone handle however is complete; it is cylindrical with a rounded butt end where the end of the iron tang protrudes very slightly. The handle is polished and decorated all over with a raised scallop design. BAACP01, SF 1335, ctx 458024, iron and bone, length 115 mm
99. (illus.) A whittle-tang knife with an elongated tapering bolster at the junction of the blade and the tang, very little of the blade survives. The bone handle is complete; it has a flattened hexagonal section and expands slightly towards the butt end, where the rounded end of the iron tang protrudes. The handle is intricately decorated with panels of fine incised crosshatched grooves and rows of ring and dot motif. The whole of the handle is highly polished. BAACP01, SF 1409, ctx 447004, iron and bone, length 100 mm
100. (illus.) A highly polished fragment from a bone 'pistol grip' handle from a whittle-tang implement. BAACP01, SF -, ctx 468004, bone, length 58 mm

#### **Scale tang knives** (Fig. 15.3, nos 101, 106, 109, 110-111)

The fragmentary remains of 11 scale tang knives were recovered, 9 from the LTCP site (BAACP01) and 2 from the FLB site. This type of knife has a handle that is formed from a narrow central strip to which scales of wood or bone are attached by rivets. There are no complete examples but there are a number with tangs that have copper alloy shoulder and end plates surviving and there are two examples with highly decorated bone scales still attached. Scale tang knives were introduced in the 13th-14th centuries and continued in use into the post-medieval period.

101. (illus.) Scale tang knife with a blade back that continues in line with the back of the tang and with a blade edge that runs parallel to the back. There are three small circular perforations through the tang. BAACP01, SF -, ctx 466019, iron, length 111 mm
102. A very damaged fragment from a scale tang knife both the blade and the tang are incomplete. There is a copper alloy shoulder plate at the junction of the blade and the tang and 2 small circular perforations through the tang. BAACP01, SF 1324, ctx 459007, iron and copper alloy, length 67 mm
103. A fragment from a scale tang knife the blade back continues in line with the back of the tang and the blade edge runs parallel. There is a single copper alloy rivet through the short section of the scale tang that survives. BAAFL00, SF -, ctx 401013, iron and copper alloy, length 120 mm

104. Three damaged fragments from a scale tang knife the blade back continues in line with the back of the tang and the blade edge runs parallel. There is a single circular perforation through the short section of scale tang that survives BAAFL00, SF -, ctx 401013, iron, length 132 mm
105. A small fragment from a scale tang knife handle with 2 small circular perforations through it. BAACP01, SF -, ctx 466010, length 53 mm
106. (illus.) A large scale tang knife the blade back continues in line with the back of the tang and the blade edge runs parallel. The tang has a curved copper alloy end-cap around the butt-end of the handle with a protruding knob at the centre. There is a copper alloy shoulder plate at the junction of the blade and the tang. Through the tang there are five circular perforations, one towards the end is much larger than the others. Three of the five perforations (including the large one) have copper alloy tubular rivets through them. BAACP01, SF 1329, ctx 467001, iron and copper alloy, length 222 mm
107. A fragment from a scale tang knife the blade back continues in line with the back of the tang, the blade edge is very damaged. There is a copper alloy shoulder plate at the junction of the blade and the tang and there are three circular perforation through what remains of the tang. The central perforation is larger than the other two and has a copper alloy tubular rivet through it. There are traces of bone from the scales still adhering to the tang. BAACP01, SF -, ctx 458024, iron and copper alloy, length 95 mm.
108. A fragment from the handle of a scale tang knife, it has a curved copper alloy end plate around the butt end and 4 circular perforations through the tang. One of the perforations towards the butt end is larger than the other three and has a copper alloy tubular rivet through it. BAACP01, SF -, ctx 452010, iron and copper alloy, length 89 mm
109. (illus.) The handle from a scale tang knife with decorated bone scales still attached. The scales are decorated with vertical grooves defining panels that are decorated with fine incised cross-hatched grooves and ring and dot motif. There are two copper alloy rivets securing the scales to the tang. BAACP01, SF 1196, ctx 459013, iron, copper alloy and bone, length 61 mm
110. (illus.) The handle from a scale tang knife with decorated bone scales still attached. The scales are decorated with vertical grooves defining panels that are decorated with patterns of ring and dot motif. There are two copper alloy rivets securing the scales to the tang. BAACP01, SF 1382, ctx 472004, iron, copper alloy and bone, length 66 mm
111. (illus.) Scale tang knife with a plain bolster and a tang set at 90° to the blade, trace of a single perforation through the tang BAACP01, SF 1203, context 480111, iron, length 135 mm

**Folding knife** (Fig. 15.3, no.112)

A fragment from a folding knife with a short section of the blade surviving inside (visible on the x-radiographic plate) was recovered from the LTCP (BAACP01). Folding knives have metal side plates with organic scales attached. This form of knife was a post-medieval development and evolved into the modern penknife.

112. (illus.) A fragment from a round ended folding knife with a fragment of the folded blade visible on the x-radiographic plate. Decorated bone scales are attached to the metal side plates; the scales are decorated with a pattern of small raised bobbles. BAACP01, SF 1212, ctx 480080, iron and bone, length 48 mm

**Dagger Chape** (Fig. 15.4, no. 113)

A fragment from a dagger chape was recovered from the LTCP. This fragment is the front half of a two piece-chape decorated with a crude open-work design and with a protruding knob at the base. Chapes acted as terminals for scabbards; they developed from simple objects constructed from sheath binding into two-piece objects that would have had a back plate soldered or brazed into place. This example is probably 15th-16th century in date (Hinton 1990b, 1082-1083, fig 348, no.4036).

113. (illus.) The front plate from a two-piece dagger chape the back plate is missing. The chape is decorated with a crude open work design and has a protruding knob at the end. BAACP01, SF-, ctx 449017, copper alloy, length 39 mm

*Tools* (Fig. 15.4, nos 114-118)

A small number of mainly horticultural or agricultural tools were recovered from the LTCP site. They comprise a spade shoe, three fragments from large curved blades (probably sickles) and the arm from a pair of shears. There is one object not associated with agriculture or horticulture and that is a possible punch. The spade shoe was designed to fit over the wooden blade of the spade and protect it from wear; this rectangular form is late 16th-17th century in date (Goodall 1983, 242, fig 5, no.52). The design of the sickle has not changed through time and therefore is not possible to date these fragments. The shears represented here are remarkably small, with a short curved arm at the top of a pronounced triangular blade; they are almost the size of scissors rather than shears. The punch has a circular flattened head as if it has been distorted through use, the shank of the possible punch is rectangular and it tapers to a wedge-shaped end.

114. (illus.) A narrow spade shoe with a square cut end and a V-shaped inner groove in the top to receive the wooden blade of the spade. The arms at the side are both incomplete but would originally have been pierced for nails to attach the shoe to the spade. BAACP01, 1346, ctx 457004, iron, length 154 mm
115. (illus.) Part of the curved blade and whittle-tang from a sickle BAACP01, SF 1221, ctx 448001, iron, length 204 mm
116. (illus.) Fragment from a large curved blade, probably a sickle, the fragment is broken at both ends BAACP01, SF -, ctx 448001, iron, length 251 mm
117. (illus.) Fragment from the pointed tip of a large curved blade, probably a sickle BAACP01, SF 1154, ctx 450014, iron, length 107 mm
118. (illus.) The arm from a small pair of shears with a pronounced triangular-shaped blade and short curved arm BAACP01, SF-, ctx 450013, iron, length 78 mm
119. A large solid object with a circular flattened head; the body has a rectangular section that tapers to a wedge-shaped end, possible punch BAACP01, SF -, ctx 458083, iron, length 120 mm

*Horsegear*

**Horseshoes** (Fig. 15.4, nos 120-145)

The remains of 38 horseshoes were recovered from various phases of excavation. The majority (25) came from LTCP site, 4 from the MTCP site, 3 from Long Border Road and 4 from the FLB site. There are 17 complete or near complete examples. The earliest type has narrow arms with a lobate profile and circular nail holes set in rectangular countersinkings there are only two examples of this type represented in the assemblage one from The MTCP site and the other from the LTCP site (BAACP01) this type of horseshoe predominates in the 12th and early 13th century (Clarke 1995, 94). The remaining shoes have wider arms (30 mm-35 mm) with plain outer profiles, three or four rectangular nail holes in the arms and an arched or U-shaped inner profile. This type of shoe introduced in the 14th century has continued in use to the present day (Goodall 1993, 225). There are five examples of shoes with nail holes set in a fullered groove, an early 17th century introduction (Goodall 1990b, 1056).

120-121 A horseshoe with narrow arms and a lobate outer profile. There are 3 circular nail holes in each arm set in rectangular countersinkings.

(illus.) BAACP01, SF 1169, ctx 448001, iron, length 121 mm (near complete)

BAAMP00, SF -, ctx 330207, iron, length 108 mm (complete)

122-129 A horseshoe with a plain outer profile an arched or U-shaped inner profile, three rectangular nail holes in each arm and calkins at the tip.

BAACP01, SF -, ctx 465026, iron, length 106 mm

- BAACP01, SF -, ctx 465023, iron, length 112 mm (incomplete)  
 (illus.) BAACP01, SF -, ctx 458024, iron, length 111 mm (near complete)  
 BAACP01, SF -, ctx 466010, iron, length 118 mm (incomplete)  
 BAACP01, SF -, ctx 459008, iron, length 106 mm (incomplete)  
 BAAFL00, SF -, ctx 401013, iron, length 90 mm (incomplete)  
 BAALB00, SF-, ctx 201023, iron, length 106 mm (complete)  
 BAAMP00, SF 994, ctx 336064, iron, length 90 mm (incomplete)
- 130-140 A horseshoe with a plain outer profile an arched or U-shaped inner profile, three or four rectangular nail holes in each arm and no calkins at the tip.  
 BAAFL00, SF -, ctx 407013, iron, length 106 mm (complete)  
 BAACP01, SF-, ctx 457026, iron, length 125 mm (near complete)  
 BAACP01, SF 1270, ctx 448001, iron, length 101 mm (incomplete)  
 BAACP01, SF -, ctx 458025, iron, length 111 mm (incomplete)  
 BAACP01, SF 1280, ctx 448001, iron, length 127 mm (incomplete)  
 BAACP00, SF -, ctx 114043, iron, length 119 mm (incomplete)  
 BAAMP00, SF 309, ctx 301001, iron, length 100 mm (incomplete)  
 (illus.) BAACP01, SF 1145, ctx 472004, iron, length 105 mm (complete)  
 BAACP01, SF 1160, ctx 448001, iron, length 114 mm (complete)  
 BAACP01, SF -, ctx 463012, iron, length 111 mm (near complete)  
 (illus.) BAACP01, SF -, ctx 457030, iron, length 125 mm (complete)
- 141-145 A horseshoe with a plain outer profile, wide arms with three or four rectangular nail holes set in a fullers groove.  
 BAACP01, SF 1204, ctx 480068, iron, length 109 mm (complete)  
 BAACP01, SF -, ctx 449017, iron, length 128 mm (complete)  
 BAALB00, SF -, ctx 201023, iron, length 125 mm (complete) .  
 BAACP 99, SF -, ctx 1601, iron, length 137 mm (complete)  
 (illus.) BAACP01, SF-, ctx 449017, iron, length 132 (complete)
146. A horseshoe with a U-shaped profile and heavy calkins at the tip of each arm. There are three rectangular nail holes in each arm, these holes taper inwards in profile from the ground surface of the shoe. BAALB00, SF-, ctx 201023, iron, length 103 mm (complete)

### Spurs (Fig. 15.5, nos 149-150, 153)

The remains of seven sets of spurs were recovered from the LTCP site. They are all examples of rowel spurs, although the actual rowel itself only survives in one example. Four of the spurs have long necks, a feature that was fashionable in the 15th-early 16th century (Ellis 1992, 176). The arms of these are relatively straight, and only curve very slightly to fit under the wearer's ankle. The other three spurs have short necks that droop, a feature which first appeared in the 16th century (Ellis 1992, 172). The arms are very straight. A number of this type are plated with tin to enhance their appearance and protect against rust.

147. An incomplete rowel spur the arms appear to slope very slightly to fit below the wearer's ankle, the ends of the arms and the terminals are missing. The circular section neck is long with a slight downward slope along its length. The six-point rowel is still *in situ*. BAACP01, SF 1215, ctx 44801, iron, length 116 mm
148. An incomplete rowel spur the arms appear to slope very slightly to fit below the wearer's ankle, the ends of the arms and the terminals are missing. The circular section neck is long

- with a slight downward slope along its length. The rowel box and the rowel are missing. BAACP01, SF 1164, ctx 480040, iron, length 98 mm
149. (illus.) An incomplete rowel spur one arm is complete and curves very slightly to fit under the wearer's ankle; it terminates in a figure of eight shaped terminal. The circular sectioned neck is very long bifurcating at the end to form the rowel box. The rowel itself is missing. BAACP01, SF 1328, ctx 467001, iron, length ?
150. (illus.) A near complete rowel spur, both arms terminate in figure of eight shaped terminals, one has a square bodied hook through it. The neck angles down and bifurcates almost immediately for the rowel. The rowel itself must have been unusually large. BAACP01, SF -, ctx 466010, iron, length 131 mm
151. An incomplete rowel spur the arms are straight and taper towards the terminals both of which are missing. The neck is short with a drooped rowel box, which broadens in to broad rowel bosses. There is a moulded collar at the junction of the spur back and the neck. The rowel is missing. BAACP01, SF 1264, ctx 448001, iron, length 112 mm
152. An incomplete rowel spur the arms are straight the neck is short and droops. Both the arms and the neck are incomplete. There are two decorative strips of copper alloy at the base of the neck. BAACP01, SF 1157, ctx 480010, iron, length 77 mm
153. (illus.) An incomplete rowel spur the arms are straight the neck is short and droops. The rowel bosses and the pin survive but the rowel itself is missing. BAACP01, SF -, ctx 449017, copper alloy, length 64 mm

*Objects associated with hunting*

**Arrowheads** (Fig. 15.5, nos 155, 163-165)

A total of 14 arrowheads were recovered, 12 from the LTCP site BAACP01) and 2 from the FLB site. Three types of arrowhead are represented in the assemblage, the straight broadhead, the crescent-shaped arrowhead and the small socketed and barbed arrowhead. All are late medieval/post-medieval forms, and would have been used for hunting. The broadheads were used to hunt large game such as deer and wild boar; the long cutting edges would have caused a large wound that would bleed profusely and weaken the pursued animal (Jessop 1996, 199). The crescent-headed arrowheads are believed to have been used to hunt small game and in particular birds (Jessop 1996, 199). The spinning motion of the forked head would make it less likely to skid off the feathers of a bird, which ordinary points have been known to do.

- 154-157 A large arrowhead with a centrally enclosed socket and two large flat barbs, it is diamond-shaped in cross section. Commonly known as a 'broadhead'
- BAACP01, SF 1180, ctx 480033, iron, length 59 mm
- (illus.) BAACP01, SF 1268, ctx 448001, iron, length 75 mm
- BAACP01, SF 1384, ctx 465023, iron, length 94 mm
- BAACP00, SF 124, ctx 114038, iron, length 89 mm
- 158-163 An arrowhead with a crescent-shaped head and a short socket, the inside of the crescent is sharpened. Commonly known as a 'forker'
- BAACP01, SF 1294, ctx 480082, iron, length 59 mm
- BAACP01, SF -, ctx 466010, iron, length 61 mm
- BAACP01, SF -, ctx 448001, iron, length 36 mm
- BAACP01, SF -, ctx 458024, iron, length 76 mm
- BAACP01, SF 1172, ctx 480026, iron, length 58 mm
- (illus.) BAACP01, SF 1171, ctx 480026, iron, length 64 mm
- 164-165 Socketed and barbed arrowheads
- (illus.) BAAFL00, SF 240, ctx 402019, iron, length 52 mm

(illus.) BAAFL00, SF -, ctx 403013, iron, length 56 mm

166-167 Sockets from arrowheads type not identifiable

BAACP01, SF -, ctx 466010, iron, length 44 mm

BAACP01, SF 1159, ctx 448001, iron, length 44 mm

## **Armour**

A possible brigandine plate was recovered from the LTCP site. A brigandine is a garment in the shape of a doublet and hose, which is lined with metal plates riveted to the inside. A typical plate would be riveted along one edge only. Examples with flat-headed copper alloy rivets recovered from Mount House, Witney, Oxfordshire have been dated to the late 15th early 16th century (Eaves 2002, 150, fig 3.15, no.67 and 72). The manufacture of brigandines generally declined in the later half of the 16th century but the Tower of London was still issuing them in the early 17th century (Eaves 2002, 150).

168. Fragment from a rectangular iron plate perforated by a row of 3 flat headed copper alloy rivets running along one edge. BAACP01, SF -, ctx 458024, iron and copper alloy, length 48 mm

### *Structural objects* (Fig. 15.5, no. 169)

With the exception of nails, only a very small number of structural items were recovered from the excavations. The assemblage comprises hinge pivots, plate hinges, hasps, staples and a handle. This probably indicates that the metalwork was salvaged from the building prior to demolition and that the nails were not considered worth retrieving and having been removed from structural timberwork they were dumped.

169-170 Hinge pivot with a circular section pintel and a rectangular section shank

(illus.) BAACP01, SF 1372, ctx 467030, iron, length 83 mm

BAAFL00, SF -, ctx 401013, iron, length 91 mm

171-172 Plate hinge both of the rectangular plates have a row of circular perforations running along the centre.

BAACP01, SF -, ctx 458024, iron, length 64 mm

BAACP01, SF -, ctx 461027, iron, length 127 mm

173 A looped hasp, curved along its length and with the remains of a hook at one end BAACP01, SF 1218, ctx 448001, iron, length 130 mm

174-175 Rectangular staple one arm is incomplete

BAACP01, SF 1162, ctx 480015, iron, length 24 mm

BAACP01, SF 1258, ctx 448001, iron, length 78 mm

176. A drop handle with a kidney-shaped frame and a perforated suspension loop. BAACP01, SF -, ctx 461001, iron, length 60 mm

### *Nails*

A total of 653 nails were recovered from the LTCP BAACP01) and the FLB sites. Six different types of nail were represented in the assemblage. The nails have been counted and tabulated by context (Table 15.2).

177. Nail with a wide rectangular section shank tapering to a wedge-shaped tip, the head is square/rectangular, flat and slightly flanged (type 1)

178. Nail with a narrow rectangular section shank and a square, flat flanged head (type 2)

179. Nail with a narrow rectangular section shank and a circular/oval flat flanged head (type 3)

- 180. Small nail with a solid square head that tapers gently into the shank, possibly a horseshoe nail (type 4)
- 181. Nail with a solid rectangular head and a slender rectangular section shank (type 5)
- 182. Nail with a rectangular section shank and a T-shaped head the same width as the shank (type 6)

**Lead objects (Fig. 15.5, no. 183)**

- 183. (illus.) A circular seal matrix with a rear suspension tab BAAFL 00, SF 251, context 401013, lead, length 23mm.

*Miscellaneous fragments*

A large number of objects from all the phases of excavation have been categorised as miscellaneous this includes fragments of sheet, strip, rod and lengths of wire that are not recognised as a specific object or part of an object. A list of these miscellaneous items will appear in the archive.

**Section 2 - Discussion by Site**

The majority of the post-Roman objects were recovered from the LTCP site (BAACP01) but smaller assemblages of medieval and post-medieval material were also recovered from the MTCP, FLB, and the LBR sites. The assemblages are discussed by site.

**The MTCP site (BAAMP99 and BAAMP00)**

A total of 10 objects were recovered from the excavations on the MTCP site. Five of these came from the topsoil (301001), two were unstratified and the remaining three were intrusive in earlier features. The assemblage comprises two knives, four horseshoes, two vessel repairs, a buckle plate and a musket ball.

The knives (Cat. Nos 91 and 92) from contexts 301001 (topsoil) and 328279 (a Late Iron Age ditch) are both whittle-tang knives with fairly broad blades, neither example is complete. Both knives also have copper alloy shoulder plates one of which (Cat. No. 91) is decorated with four horizontal raised ridges with the design mirrored on the end cap, which is now detached. The four horseshoes are all incomplete and either come from the topsoil or from Romano-British contexts (336064 and 330207). The example from context 330207, a Romano-British ditch (Cat No. 121) has a lobate profile and three circular holes in each arm that are set in rectangular countersinkings. There is also a slight calkin at the tip of each arm. This type of horseshoe predominates throughout the 12th century but is replaced by a heavier more developed type sometime in the 13th century (Clark 1995, 96). Cat No. 129 from context 336064 (a Romano-British waterhole) also has three circular holes through the arm set in rectangular countersinkings but the profile is plain and the web is broader. This type predominated in the 13th century but declines in numbers in the 14th century (Clarke 1995, 96). Cat. No 136 from the topsoil (301001) is probably of the same type but has four nail holes through the surviving arm. The final fragment (SF 1094) also from the topsoil is undiagnostic.

Two paperclip rivets (Cat. Nos 72 and 73) were recovered from unstratified contexts. These folded strips of sheet metal would have been used to hold sheet metal vessel



repairs in place (Margeson 1993, 93, fig 59, No.575) and are medieval/post-medieval in date. Cat. No. 42 is a folded sheet metal buckle plate recovered from the topsoil, with a recess for the pin and four rivet holes for attachment. A musket ball (SF 1050) was recovered from an unstratified context.

### **The LBR site (BAALB00)**

The small assemblage from the LBR site dates mainly to the Romano-British period (see Scott, CD Chapter 14). However the assemblage includes three late medieval/post-medieval horseshoes from context 201023 (secondary fill of a Romano-British trackway). Two examples (Cat. No 128 and 146) have plain out-side edges, heavy calkins, and three nail holes in each arm that taper inwards in profile from the ground surface of the shoe. This is a late medieval feature (Clarke 1995, 88-97). The third example (Cat. No. 143), a large shoe with four holes in each arm set in a fullers groove is a 17th century or later type (Goodall 1990b, 1056).

### **The FLB site (BAAFL00)**

A total of 78 objects were recovered from the excavations of the FLB, of which all the identifiable objects are medieval/post-medieval in date. The assemblage comprises 19 identifiable objects, 44 nails and 15 miscellaneous fragments. The majority (15) of the identifiable finds come from topsoil and subsoil layers. The functional categories represented in the assemblage are personal items, household objects, horsegear, hunting and structural objects. Diagnostic objects recovered from the top soil/subsoil layers 401013, 402019 and 403013 include buckles, horseshoes, knives, arrowheads, a key and a seal matrix.

The personal items include a distinctive buckle (Cat. No.39) of mid 14th-early 15th century date (Egan and Pritchard 1991, 78-82) with an oval frame and rigid composite plates (only the forked spacer survives). A possible annular brooch (Cat. No. 46) decorated with cable design is similar to examples from London dating to the late 13th-early 14th century (Egan and Pritchard 1991, 248-250).

The horsegear comprises four horseshoe fragments two of which are undiagnostic. The remaining two horseshoes Cat. Nos 127 and 130 include a near complete example from context 407013 (the cobbled surface of a track). They both have plain profiles with three nail holes in each arm outline and Cat No. 127 has a calkin at the tip of the arm. This type of shoe is a late medieval form introduced in the late 13th -mid 14th century and becoming universal by the 15th century (Clarke 1995, 96-97).

The three knives comprise one complete whittle-tang knife (Cat No. 84) and two fragmentary scale tang knives. The whittle-tang knife has a pronounced triangular-shaped blade and a centrally placed tang this form dates from the late 13th - late 14th century (Cowgill *et al.* 1987, fig 55, no.28 and fig 60, no.88). The scale tang knives (Cat. No. 103 and 104) have perforations through the tang for securing the scales.

The key (SF 250, Cat No. 77) has a ring bow and a hollow stem. The bit, although damaged, is simple; it is a common form of key mainly in use from the 11th -14th centuries (Goodall 1990a, 1001-1036). The two arrowheads (Cat. No. 164-165) are

both socketed barbed and tanged arrowheads, which could have been used for either military or hunting purposes (Goodall 1990c, 1070-1074, fig. 344, No. 4014)

A circular seal matrix (SF 251) dating from the 13th or early 14th century with a rear suspension tab was recovered from context 401013. The legend is difficult to decipher and two possibilities are posited; either + S' ION TOVRLE or +S'ION POVRTE. In both cases there is little argument about the 'S' being an abbreviation for 'sigillum' ('seal of') and for 'ION' probably being an abbreviation for Iohannis (John). The alternatives offered for the surname differ because most of the first letter is obliterated, leaving only the descender. This first letter has been interpreted as either a 'T' for 'Tourle' or a 'P' for 'Pourte' the second contentious letter is the penultimate one which has been deciphered either as an 'L' or a 'T' (as it appears to have a cross bar).

Documentary records give a reference to a John Tourle but unfortunately it relates to 18th century Sussex. However a John Pourte does appear in the records as a witness to a certificate of debt between two London merchants in 1316 (NA C241/82), and possibly the same John Pourte was a witness to deeds in Aveley in 1338, 1339 and 1348, and Wennington Marsh in 1342, 1344, 1345 and 1347 (ERO D/DL/T1/21, 71, 72, 101, 107, 108, and 124). Aveley and Wennington are in south-west Essex near to West Thurrock. In c.1280 a William Pourte made a grant and was mentioned in an abutment in Hatfield Regis, less than 10 miles from Stansted (ERO D/DBa T1/23 and 33).

### **The LTCP site (BACCP99 and BAACP00)**

The majority of the metal objects recovered from the sites are Romano-British in date (see Scott, CD Chapter 14). However there are three objects in the assemblage that date to the late medieval/post-medieval period: an arrowhead and two horseshoes. The large but very damaged barbed and socketed arrowhead (Cat. No. 157) was recovered from context 114038, the final deposition layer in the cut of Late Romano-British enclosure ditch. This type of late medieval/post-medieval arrowhead is commonly known as a 'straight broadhead' and was used to hunt large game such as deer and wild boar. The horseshoe (Cat. No. 135 from context 114043, a post-medieval subsoil) has a plain outline, three rectangular nail holes in each arm and a folded calkin at the end of one of the arms. This is a type of shoe common in the 13th and 14th centuries, but superseded in the 15th century (Clarke 1995, 96). The second shoe (Cat. No. 144) recovered from topsoil has narrow webs and three rectangular holes in each arm set in a fullers groove, which is a post-medieval introduction (Goodall 1990b, 1056).

### **The LTCP site (BAACP01 - The hunting lodge)**

The majority of the post-Roman metalwork recovered from the Stansted Airport excavations comes from the LTCP site (hunting lodge). The assemblage comprises 949 objects, of which 908 are identifiable (653 of these being nails). The functional categories represented in the assemblage are personal accessories (146), domestic items (11), lock furniture (8), knives (25), tools (6), horsegear (32), objects associated with hunting (16) and structural objects (10 excluding the 653 nails).

A large number of the identifiable objects were recovered from modern ploughsoil, modern topsoil and subsoil layers. There are only 78 identifiable objects (other than nails) that were recovered from phased stratified contexts.

Personal accessories form the largest group of identifiable objects from the excavation, and lace tags (24), pins (64) and fasteners (7) predominate. Other finds include buttons (7), buckles (30), mounts (8) and a patten.

Lace tags are a common find in post-medieval contexts, as a result of the fashion for tighter fitting garments in the late medieval and early post-medieval periods (Egan and Pritchard 1991, 284). Stratified lace tags of type 1 and type 2, (dating mainly to the 15th century, and to a lesser extent the 16th -17th centuries) were recovered from deliberate backfilling (467023 and 472001) of ditch 466020 and from 467014 (the backfilling of a phase 3 ditch that probably derived from midden 467008).

The majority of the 64 pins recovered from the excavation derived from unstratified contexts. The 26 stratified examples are all small wire pins with spiral wound or spherical heads (types 1 and 2). These are common finds in late medieval and post-medieval contexts and were probably used to secure light clothing. Nineteen pins came from deliberate backfills - nine were recovered from 459027 and 459028 (the backfill of hearth 459026), five pins came from phase 3 ditches that had been backfilled with material from midden 467008, whilst others came from 447011 (the backfill of latrine pit 447014) and from contexts 459007 and 459008 (deliberate backfills of pit 459005).

Other stratified examples were recovered from a packed clay floor surface (467042) within the phase 2 kitchen and an extended area of cobbling associated with the phase 3 farmhouse (472004).

Loop fasteners and hook and eye fasteners are also found in large numbers in medieval and post-medieval contexts, often associated with assemblages of pins and lace tags. They are believed to have been used to fasten light garments (Margeson 1993, 20, fig 10, no. 101). The two stratified examples were found in contexts associated with the phase 2 kitchens; 449078 is a backfilled depression probably associated with the use of the kitchens and context 472009 is a backfilled depression outside the kitchens probably associated with the demolition or modification of the buildings.

All seven buttons recovered from the excavations were from unstratified contexts. They are all post-medieval in date. All are of simple form, predominantly circular and discoidal with either integral wire loop attachments (Biddle and Cook 1990, fig 155, no. 1760) or short rectangular perforated shanks (Biddle and Cook 1990, fig. 155, no. 1752). There is one circular dished button with four holes at the centre for attachment, and a two-piece button consisting of a copper sheet metal cover over an iron back. The upper face has an embossed decoration on it.

A total of 30 buckles of iron and copper alloy were recovered the assemblage, including simple utilitarian forms (some of which may have been used on harness fittings rather than as dress fittings) and more ornate examples which include shoe

buckles. Only nine buckles were from stratified contexts, three of which were deliberate backfills.

An iron pin (Cat. No. 44) from a large buckle frame (almost certainly associated with harness) was recovered from context 461001, the backfill of robber cut 461014. A simple D-shaped frame of utilitarian form (Cat. No. 21) was recovered from context 459008, the deliberate backfill of pit 459005, whilst a small annular buckle (Cat. No. 14) probably used for securing light clothing (Hinton 1990c, 511; Margeson 1993 32, fig 18. Nos 206-217) was recovered from 467034, the deliberate backfill of phase 3 ditch 467038.

The primary and secondary fills of ditch 466020 produced two buckles. An iron trapezoidal buckle frame (Cat. No. 31) came from secondary fill 472003. Frames of this shape were used to secure straps of differing widths (probably harness) some have sheet metal rollers (Cat No. 32) to aid the movement of the strap through the frame. A double oval shoe buckle (Cat. No. 34) dating to the 17th century (Margeson 1993, 28, fig 17, no. 174) came from primary fill 452015; the frame has expanded pin rests that are decorated with raised bobbles in the form of a flower.

Four buckles were recovered from contexts associated with the phase 3 outhouse (1). SF 1207 (Cat. No. 35) a late 16th-17th century shoe buckle (Zeepvat 1992, 142, fig. 53, no. 39) was recovered from cobbled surface 472004. It has four knobs, one at each corner and lobes at the junction of the bar and frame. A 14th-15th-century cast rectangular buckle frame (Cat. No. 20.) came from the same context (Williams 1978, fig 22.10; Margeson 1993, 28, fig 14, no. 145), as did a late medieval locking buckle (Cat. No. 40). This has a rectangular frame and an off-centre combined bar and pin. The holes for the bar are flanged for extra strength and there is a groove in the outside edge by which the arm was held closed. A fourth buckle frame with an elongated D-shaped frame (Cat. No. 29) was recovered from mortar flooring 465029 within the phase 3 outhouse.

All the mounts recovered from the site are either from the topsoil or they are unstratified. The majority are circular, plain domed sheet metal mounts with separate rivets. They would probably have been used in combination with other mounts to form a decorative effect on girdles and other straps or possibly on purses and shoes (Egan and Pritchard 1991, 162). One large circular mount (Cat. No. 48) may (because of its size) have been used on horse harness rather than dress. One small solid, circular domed mount has two integral spikes on the flat back for attachment.

One complete bell and the fragmentary remains of three others were recovered from the topsoil/subsoil (448001 and 448002) and the secondary fill of a Late Iron Age ditch. Two types of bell are represented; cast crotals and sheet metal pellet bells. Crotals would have been used on harness; the smaller pellet bells could have been used to decorate dress or harness. Bells are a common find in the medieval and post-medieval periods (Hinton 1990d, 726).

A single patten fitting (Cat No. 61) was recovered from context 447004, the deliberate backfill of a robber cut associated with the demolition and abandonment of the site. Pattens were used as an overshoe in wet and muddy conditions and consisted of a wooden sole, beneath which projected an iron framework. This patten has a ring with

2 angled brackets to attach it to the wooden sole. A similar example recovered from Great Linford came from a 17th century context (Zeepvat 1992, 150-151).

A very small number of domestic items were recovered from the site. The assemblage comprises six thimbles, a needle, a spoon, a weight and fragments from three vessels. Only three of these objects are from stratified contexts.

There are three forms of thimble present in the assemblage. They date from the late medieval period to the 18th century. Only one thimble (Cat. No. 65) is from a stratified context. It dates to the 17th century (Holmes 1988, 2) and has straight sides with machine applied indentations and was made in two pieces. The thimble was recovered from context 449026, the secondary fill of a ditch associated with the funnels of a deer drive (funnel 3). SF 1228 (Cat. No. 64) is intrusive in a Late Iron Age pit (context 450016). The remaining four thimbles (types 1 and 3) and the needle were recovered from topsoil or ploughsoil.

The remains of a small spoon bowl and a rolled lead weight (possibly used on a fishing net) were also recovered from the topsoil.

The three vessel fragments are all from cast metal vessels. The two stratified examples (Cat. Nos 70 and 71) are from deliberate backfills (contexts 462015 and 461027) associated with the abandonment and disuse of the site. The third and most complete fragment is from the topsoil.

The lock furniture includes seven keys and a leaf spring from a padlock bolt. The keys are all for mounted locks, with five from stratified contexts. A late medieval key (Cat. No 75), type 1, and the leaf spring (Cat. No.83) were recovered from context 466010, a secondary fill of later medieval pond 466001. A second key (Cat. No. 76) of late medieval date was recovered from context 472004 (sealing a phase 3 cobbled surface). The remaining three keys (type 3 - Cat. Nos 79, 80 and 82) of late medieval /post-medieval date were recovered from all recovered from deliberate backfills associated with the abandonment of the site (contexts 447004, 467014 and 467020).

A large number of knives were recovered from the excavation. Whittle-tang and scale-tang knives are both represented, and many still have handles attached. Although the majority are from unstratified contexts, they form a coherent group of late medieval/post-medieval forms. There are 14 examples of whittle-tang knives with rod-shaped tangs, 6 of which have bolsters (a widening at the junction of the blade and tang introduced in the 17th century). Only 4 whittle-tang knives are from stratified contexts. The earliest knife (Cat. No. 85) is from context 467014, the deliberate backfill of a phase 3 ditch. The knife, which is probably of late medieval date, is in poor condition, but the tang and back of the blade run straight and the remains of the blade edge runs parallel with the blade back. The remaining three stratified knives are post-medieval in date. They all have bolsters and the remains of bone handles attached. SF 1381 (Cat No. 94, from 447012, the deliberate backfill of a phase 2 latrine pit) and SF 1401 (Cat. No. 96 from context 466022 the secondary fill of a post-medieval ditch) both have plain polished handles with hexagonal section. SF 1409 (Cat. No. 99 from context 447004, deliberate backfill of a robber cut associated with the demolition of the site) also has a handle with a hexagonal section but it is highly decorated with panels of fine incised cross-hatched lines (which would also

improve the grip) and rows of ring and dot motif, a common type of decoration in the post-medieval period (MacGregor 1985, 170).

All of the scale tang knives are incomplete. Only five of the nine examples recovered are from stratified contexts and three of these are handle fragments only. SF 1329 (Cat. No. 106 from context 467001, the deliberate backfill of a phase 3 gully) is the most complete example with a large part of the blade surviving. The blade back continues in line with the back of the tang and the blade edge runs parallel, although the tip of the blade is missing. The tang has five non-ferrous tubular rivets through it - the hole closest to the pommel is much larger than the rest and may well have been left open to allow the knife to be suspended from a belt. The handle also has a non-ferrous shoulder plate and end cap, common features on scale tang knives (Ottoway 2003, 273). SF 1382 (Cat. No. 110, from context 472004, a cobbled surface) has little of the blade surviving but the tang has bone scales attached that are decorated with incised lines and ring and dot motif. An identical example was recovered from Denny Abbey, from a post-Dissolution context (Goodall and Christie 1980, 261, fig 56, no. 2). Handle SF 1196 (Cat. No. 109, from context 459013) is decorated in a similar way. The remaining three fragments (Cat. Nos 101, 102 and 105) from context 466019 (secondary fill of ditch 466020), context 466010 (secondary fill of later pond 466001) and context 459007 (deliberate backfill of pit 459005) are just incomplete blade and tang fragments with perforations through the tang to attach the scales, they have no other distinguishing features.

The majority of the knives recovered from the site are small examples with decorated handles that would have been designed to be used as table knives rather than carried around in scabbards. However there is a single fragment from a dagger chape (Cat. No. 113, recovered from topsoil context 449017). This fragment is the front half of a two piece-chape decorated with a crude open-work design and with a protruding knop at base. Chapes acted as terminals for scabbards, they developed from simple objects constructed from sheath binding into two piece objects that would have had a back plate soldered or brazed into place, this example is probably 15th or 16th century in date (Hinton 1990b, 1082-1083, fig 348, no. 4036).

A fragment from a folding knife (Cat. No. 112) was recovered unstratified (context 480080). The x-ray reveals a fragment of the folded blade inside the metal side plates. These plates have bone scales attached, which are decorated with a raised bobble design. This form of knife was a post-medieval development that evolved into the modern day penknife.

The tool assemblage comprises a very small number of mainly horticultural/agricultural tools. They include a spade shoe, three fragments from large curved blades (probably sickles), the arm from a pair shears and a punch. Only the spade iron and the punch are stratified. The spade shoe (Cat No. 114 from context 457004, related to phase 3 outhouse 2) was designed to fit over the wooden blade of the spade and protect it from wear. This rectangular form is late 16th -17th century in date (Goodall 1990, 1056). None of the sickle fragments are from stratified contexts. The shears (also unstratified) are remarkably small, with a short curved arm at the top of a pronounced triangular blade; they are almost the size of scissors. The only other tool recovered from a stratified feature is a punch (Cat. No. 119, from context 458083, fill

of posthole 458079). It has a circular flattened head (possibly distorted through use) whilst the shank is rectangular and it tapers to a wedge-shaped end.

The horsegear recovered from the site includes horseshoes (25), spurs (7) and harness fittings (discussed above under buckles). Only seven of the horseshoes were from stratified contexts the majority of them date to the late medieval or post-medieval period. There is one example of a medieval type (Cat. No. 120) with the characteristic lobate profile and circular nail holes in rectangular countersinkings, recovered from the topsoil (448001). All the stratified examples have wide arms (30 - 35mm) with plain outer edges and arched or U-shaped inner profiles. They have three or four rectangular nail holes in each arm. This type of shoe, introduced in the 14th century, has continued in use to the present day (Goodall 1993, 225). They were recovered from the deliberate backfills of pit 459005, phase 1 boundary ditch 457029 and from phase 2 cobbles 465023, phase 2 floor surface 465026, phase 3 cobbles 472004 and the secondary fill (466010) of the late medieval pond 466001.

The remains of seven sets of spurs were recovered from the site. They are all examples of rowel spurs, although the actual rowel itself only survives in one example. There are only two sets of spurs from stratified contexts. A near complete example, (Cat. No. 150) was recovered from context 466010, a secondary fill of the later medieval pond 466001. The arms of the spur curve very slightly to fit under the wearers ankle, and both arms terminate in a figure of eight shaped terminal. One terminal has a square bodied hook through it. The neck angles down and bifurcates almost immediately for what must have been a fairly large rowel. The other stratified example, SF 1328 (Cat. No. 149 from context 467001, the deliberate backfill of a phase 3 ditch) has only one arm surviving that barely curves at all and terminates in a figure of eight shaped terminal; the neck is long and the rowel is missing. Spurs with long necks were fashionable in the 15th - early 16th century (Ellis 1992, 176), when the general trend was towards elongating and pointing shoes. The unstratified examples include three spurs with short drooping necks, a feature which first appeared in the 16th century (Ellis 1992, 172).

A total of 11 arrowheads were recovered from the site. Two types of arrowhead are represented; the straight broadhead and the crescent-shaped arrowhead. They are both late medieval/post-medieval forms, and would have been used for hunting. Only two arrowheads (one of each type) were recovered from stratified contexts. The broadheads were used to hunt large game such as deer and wild boar. The long cutting edges would have caused a large wound that would bleed profusely and weaken the pursued animal (Jessop 1996, 199). The stratified example (Cat. No. 156) was recovered from context 465023; a phase 2 cobbled surface. The crescent-headed arrowheads are believed to have been used to hunt small game and in particular birds (Jessop 1996, 199). The spinning motion of the forked head would make it less likely to skid off the feathers of a bird. The stratified example (Cat. No.159) came from context 466010, secondary fill of the later medieval pond 466001)

A single fragment of rectangular iron sheet (Cat. No. 168) recovered from context 458024 (ploughsoil) has a row of flat headed copper alloy rivets running along one edge it is possibly a fragment from a brigandine plate. A brigandine is a garment in the shape of a doublet and hose, lined with metal plates riveted to the inside. The first reference to the use of these plates in England dates to 1397 and widespread use is

attested from the second quarter of the 15th century until the mid 16th century. After this the manufacture of brigandines generally declined, but the use of old brigandines continued into the 17th century (Starley 2005).

With the exception of the large number of nails (653), a very small number of structural items and object associated with household furniture were recovered from the excavation. The assemblage comprises hinge pivots, plate hinges, hasps, staples, a handle and window came fragments. Stratified objects derive from the fill deliberate backfilling of a robber cut 461014 and brick lined well 461038. The paucity of structural items probably indicates that the metalwork was salvaged from the building prior to demolition and that the nails were not considered worth retrieving, and having been removed from structural timberwork they were discarded.

### *Conclusion*

The large assemblage of metalwork recovered from the site appears to be functional and utilitarian in nature. There are no high status items, the personal objects include buckles and mounts for belts, straps and shoes but no items of jewellery or delicate objects of a more feminine nature. The domestic items include sewing equipment for repairing garments, vessels and vessel repairs but little else of a household nature. There are very few tools or agricultural implements to suggest large scale farming activities or crafts. It is the objects associated with horses and hunting that predominate; horseshoes, harness fittings (including buckles, mounts and bells) spurs, arrowheads, and knives reflect the use of the site as a hunting lodge. Structural items (with the exception of nails) and household furniture are practically non-existent implying that when the site was demolished and abandoned the metalwork was salvaged.

The majority of the stratified objects were recovered from episodes of deliberate backfilling associated with the demolition of phase 2 and phase 3 buildings and the ultimate abandonment of the site. There is little doubt that the finds assemblage originates from buildings where hunting and equestrian pursuits are taking place but the bulk of the metalwork can only be broadly dated to the 15th-17th centuries generally because they are functional objects whose form has changed little over time.



Table 15.1: Number of medieval and post-medieval metal objects by site

Site code	Copper alloy	Iron	Lead	Total
<b>BAACP99/BAACP00</b>	-	2	-	2
<b>BAACP01</b>	161	779	9	949
<b>BAAMP99/BAAMP00</b>	3	6	1	10
<b>BAAFL00</b>	5	72	1	78
<b>BAALB00</b>	-	3	-	3
<b>Totals</b>	169	862	11	1042

Table 15.2: Nails recovered from medieval and post-medieval contexts

Context	Total No. of nails	undiagnostic	Type 1	Type 2	Type 3	Type 4	Type 5	Type 6
447004	6				6			
447011	1				1			
448001	161	83	1		43	34		
449017	6	2		2	2			
449064	3	2	1					
449072	3				3			
450023	3			1	2			
450041	4				4			
452010	1				1			
453009	31	19			9	3		
453010	1			1				
453012	19	13			6			
453015	10	7			2	1		
455007	1				1			
457004	2			2				
457014	3				3			
457017	2				2			
458024	38	12	1	5	17	2	1	
458025	9	3			5	1		
458033	4	3			1			
459005	18				18			
459006	6	4	1		1			
459007	5	3			2			
459008	57	20		1	36			
459009	6	2			4			
459010	1	1						
459024	2	2						
459027	10	9			1			
459028	2	1			1			
459068	2				2			
460019	1				1			
461001	8	2			6			
461027	1			1				
461035	1				1			
465023	3	1		1	1			
465026	6			1	3	2		
465028	2	2						
465029	3	3						
465040	2	1			1			
465042	1				1			
466003	2				2			
466010	34	8	2	3	16	5		
466028	1				1			
466035	1				1			
467008	8	1		1	5	1		
467014	3		1		2			
467022	3				3			
467023	2	1			1			
467029	6	3			2	1		
467034	1	1						
468004	2	1			1			
472002	7	5			2			
472003	1				1			
472004	12			1	8	3		
472005	2	1			1			
472007	1				1			
472011	2				2			

480034	3	3						
480048	4				3	1		
480054	13	2		2	7	2		
480055	2				2			
480063	2			1	1			
480071	13	1			9	3		
480072	11	1			10			
480081	4	1			1	2		
480083	4	1			3			
480091	3	2			1			
480092	2				2			
480116	4	2			2			
401013	20	10			9			1
401023	7	7						
402019	9	8					1	
402020	1	1						
403001	2	1			1			
404003	1				1			
404020	1	1						
404022	1				1			
405012	1	1						
405048	1	1						
405065	1	1						
405069	2	1						1
406022	1				1			
406022	3	2						1
407001	2	2						
409021	1				1			
409028	1	1						
<i>Totals</i>	<i>653</i>	<i>266</i>	<i>7</i>	<i>23</i>	<i>291</i>	<i>61</i>	<i>2</i>	<i>3</i>

*Table 15.3: Context summary table for the identifiable/diagnostic objects from the MTCP site*

<i>Context</i>	<i>Phase</i>	<i>Copper alloy</i>	<i>Iron</i>	<i>Lead</i>	<i>Total No. objects</i>
1006	Unphased	Paperclip rivet			1
301001	Topsoil	Paperclip rivet, buckle plate	Knife, 2 horseshoes		5
328279	Late Iron Age		knife		1
336064	Romano-British		Horseshoe		1
330207	Romano-British		Horseshoe		1
Unstratified	Unphased			Musket ball	1
<i>Total</i>					10

Table 15.4: Context summary table for the identifiable/diagnostic objects from the FLB site

Context	Phase	Copper alloy	Iron	Lead	Total
401013	Unphased	2 buckles and a brooch	3 horseshoes, hinge pivot, key, knife	Seal matrix	10
402019	Unphased	Buckle	2 knives, an arrowhead,		4
403013	Unphased	-	Arrowhead		1
407013	Cut	-	Horseshoe		1

Table 15.5: Context summary table for the identifiable/diagnostic objects from the LTCP site (BAACP01)

Context	Phase	Copper alloy	Iron	Total No. objects
438001	Phase 3	Pin and a mount		2
447004	Demolition and abandonment		Patten, knife, key	3
447011	Phase 2 Latrine	Pin		1
447012	Phase 2 Hall		Knife	1
449026	Funnel 3	Thimble		1
449077	Phase 3 ditches	Fastener		1
452015	Phase 2 enclosure/Phase 3 Barn	Buckle, 2 Pins		3
457004	Phase 3 outhouse (2)		Spade shoe	1
457030	Phase 1 boundary ditch / Phase 2 enclosure		Horseshoe	1
458025	Phase 2 cobbles		Horseshoe	1
458083	Phase 2 bridge abutment		Punch	1
459007	Demolition and abandonment	Pin	Knife	2
459008	Demolition and abandonment	Pin	Horseshoe, buckle	3
459022	Demolition and abandonment	Pin		1
459027	Phase 2 Hall	7 pins		7
459028	Phase 2 Hall	Pin		1
461001	Well all phases/demolition and abandonment	Pin	Buckle and a drop handle	3
461015	Bricklined well	Pin		1
461027	Brick lined well/well all phases/demolition and abandonment		Vessel and hinge	2
462015	Funnel 3		Vessel	1
465023	Phase 2 cobbles		Horseshoe and arrowhead	2
465026	PM layer		Horseshoe	1
465029	Phase 3 outhouse		Buckle	1
466010	Later medieval pond		Spur, knife, Padlock bolt, key, 2 arrowheads and a horseshoe	7
466019	Phase 2 enclosure / phase 3 barn .		Knife	1
466022	Phase 2 enclosure / phase 3 barn		Knife	1
467001	Phase 3 ditch		Spurs and knife	2
467013	Phase 3 ditch	Pin		1
467014	Phase 3 ditch	Pin and 2 lace tag	Knife and key	5
467020	Phase 3 ditch		Key	1
467022	Phase 3 barn	Pin		1
467023	Phase 2 enclosure	Lace tag and 3 pins		4
467030	Phase 2 Kitchen		Hinge	1
467034	Phase 3 ditch		Buckle	1
467042	Phase 2 Kitchen	2 pins		2
472001	Phase 2 enclosure / Phase 3 barn	Lace tag		1
472003	Phase 2 enclosure		Buckle	1
472004	Phase 3 cobbles	Pin and 3 buckles	Knife, horseshoe	6
472009	PM layer	Fastener		1
480034	Phase 3 ditch		Buckle	1
Total number of stratified objects				78

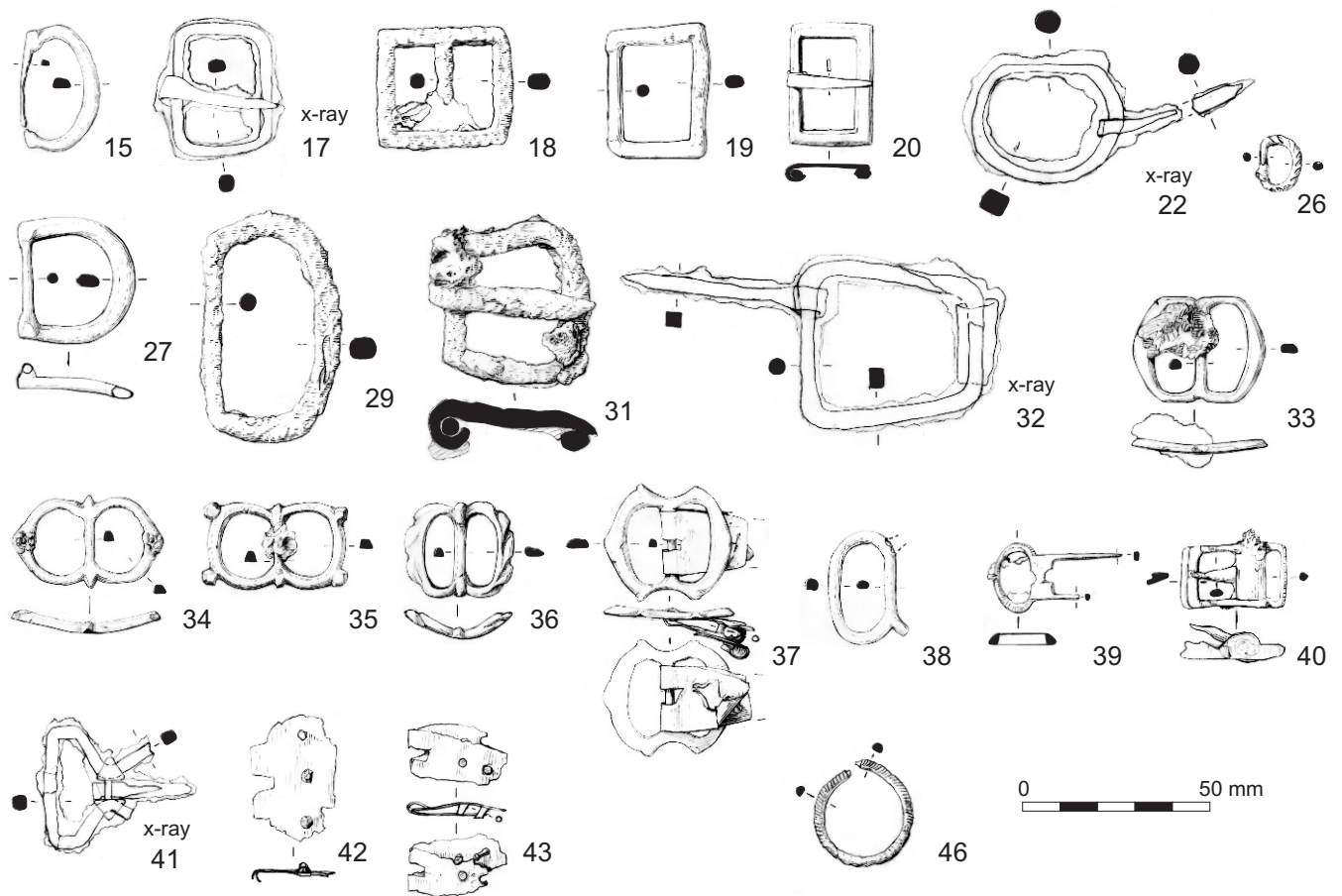
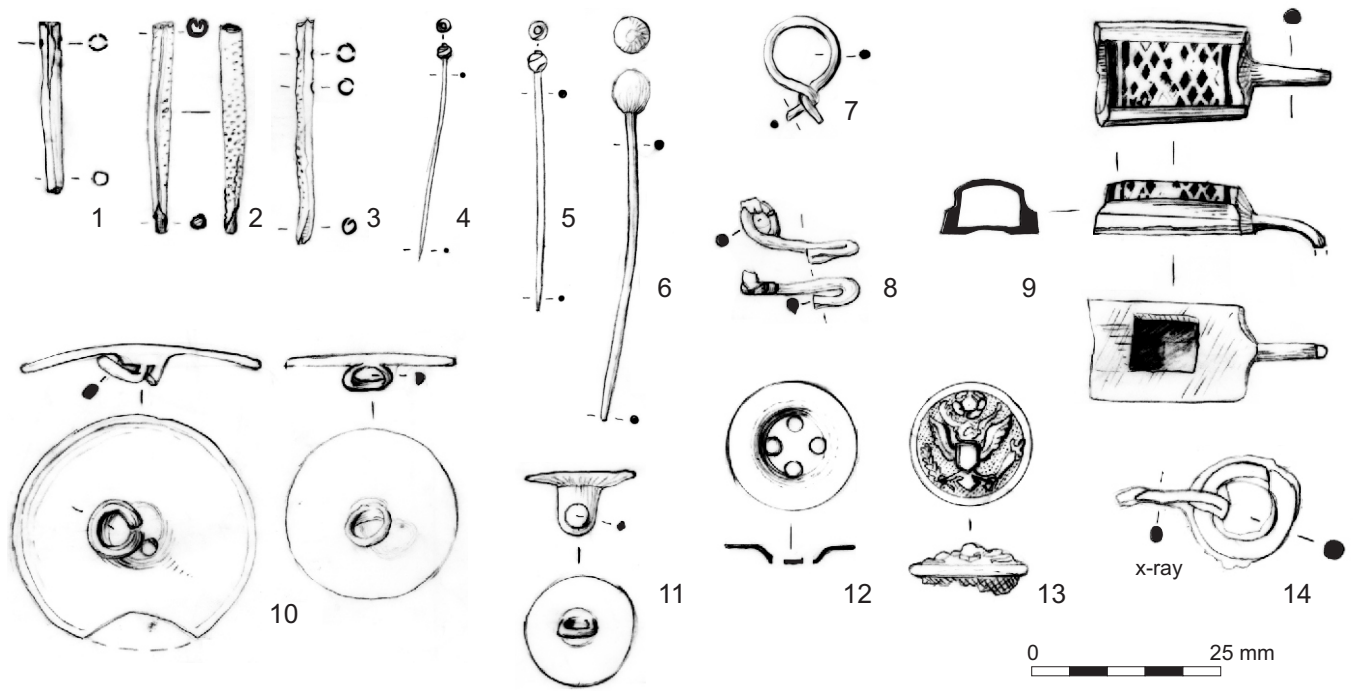

Figure 15.1: Selected metalwork (details in the catalogue)

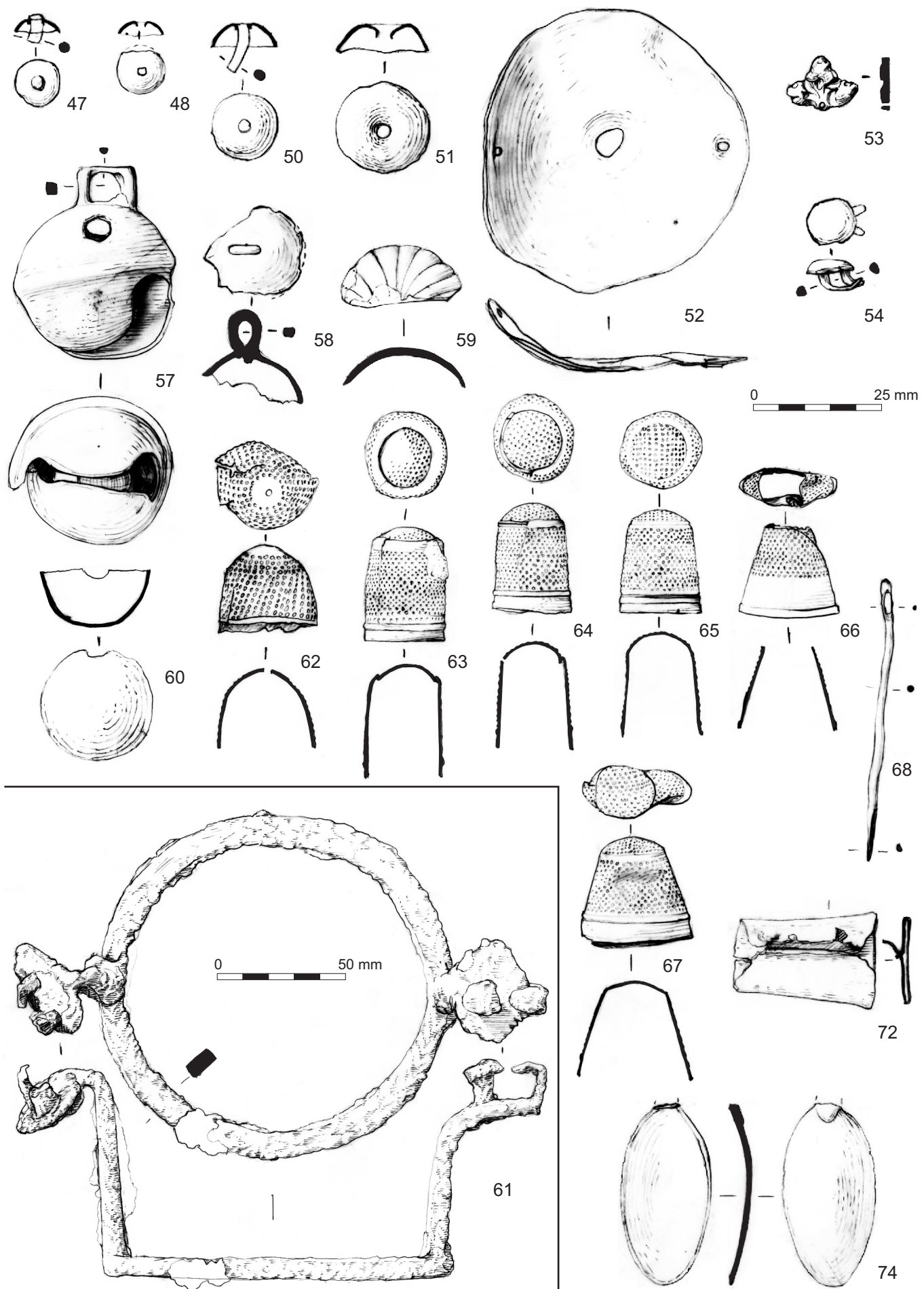

Figure 15.2: Selected metalwork (details in the catalogue)

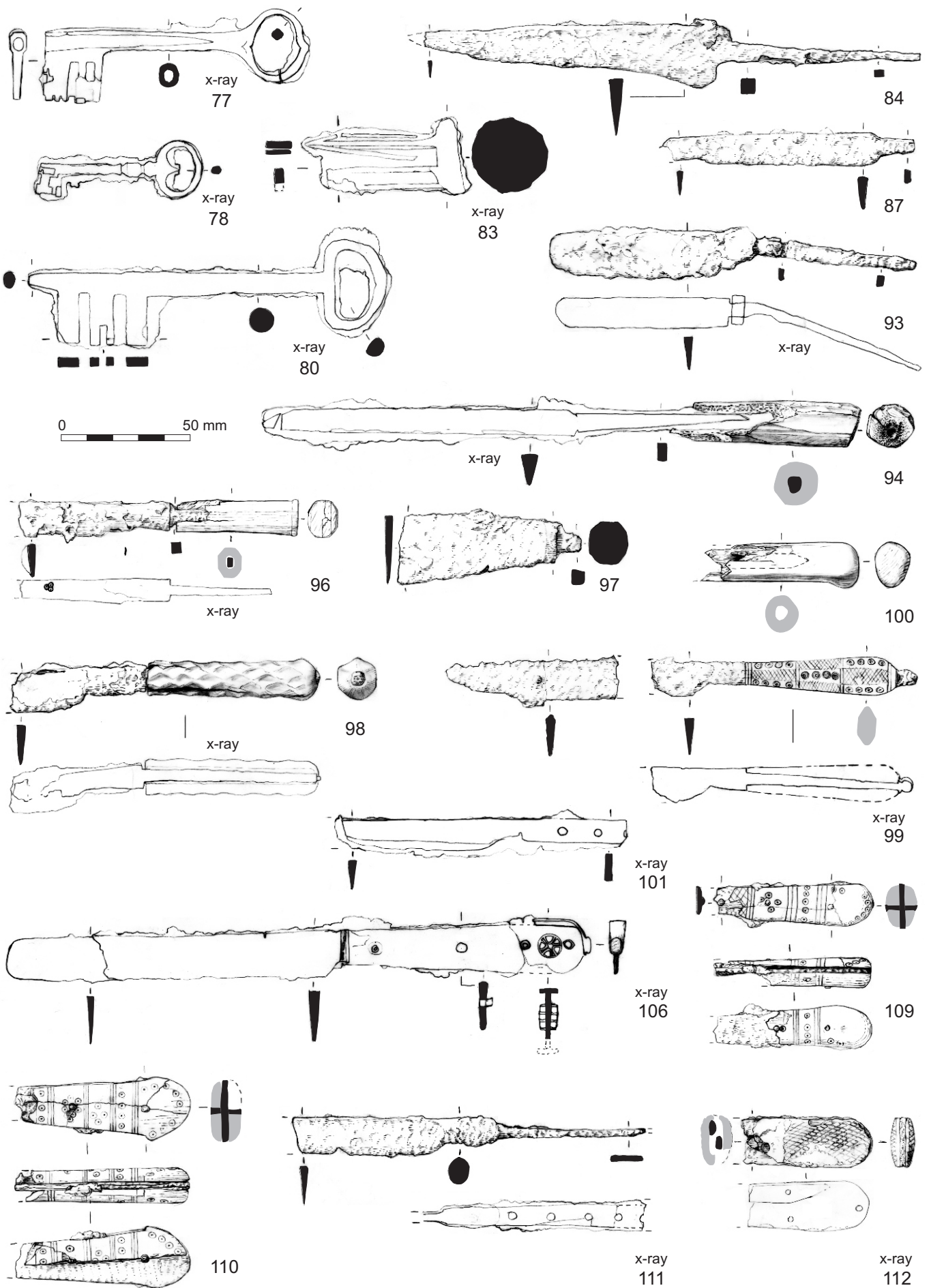

Figure 15.3: Selected metalwork (details in the catalogue)

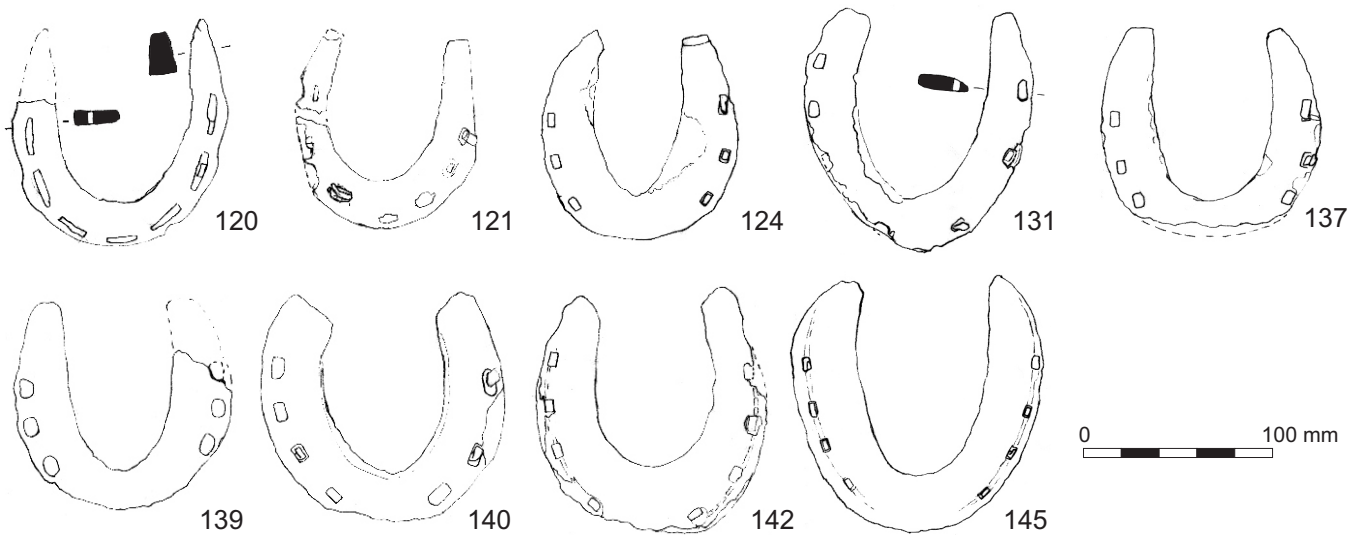
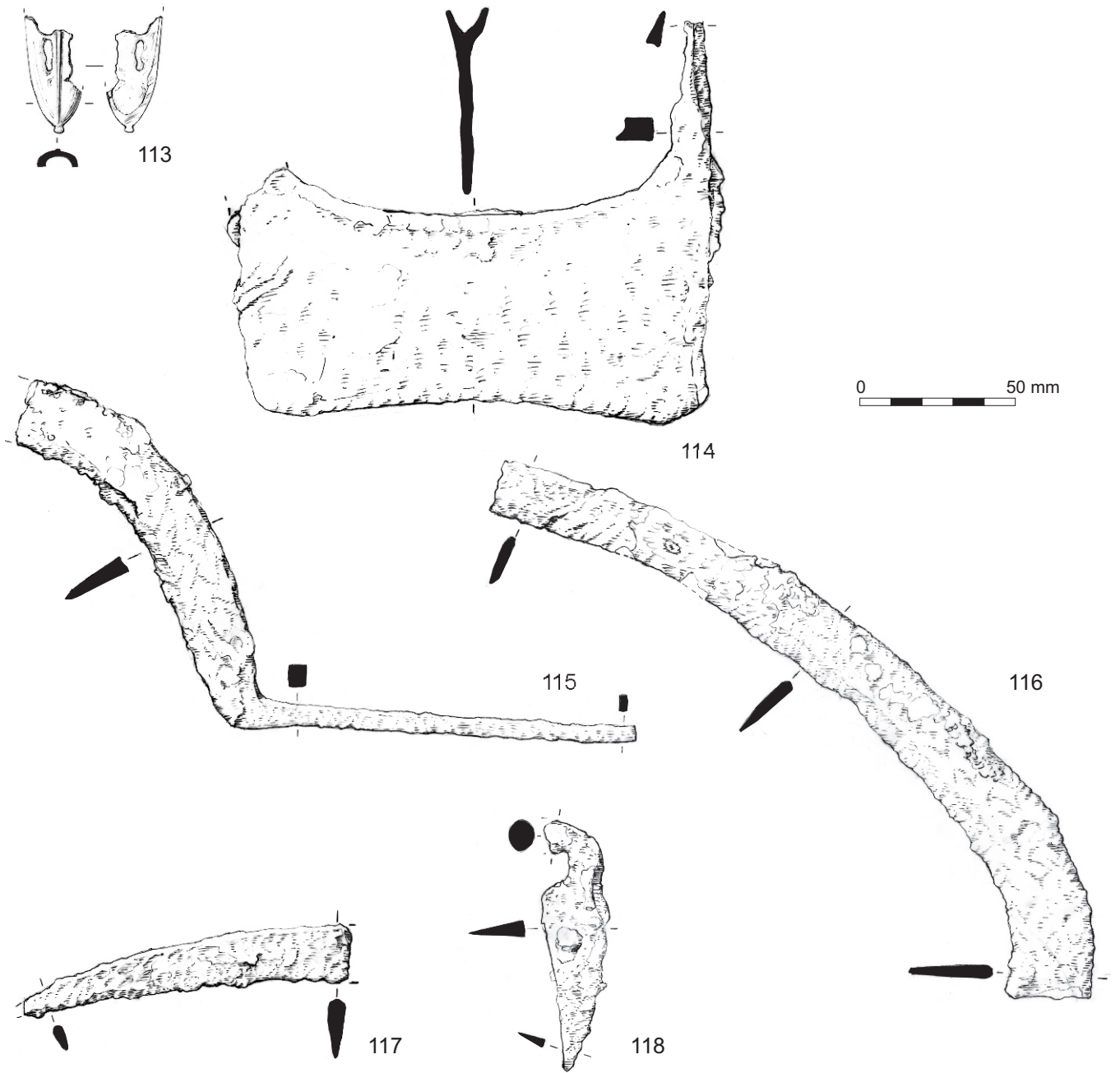

Figure 15.4: Selected metalwork (details in the catalogue)

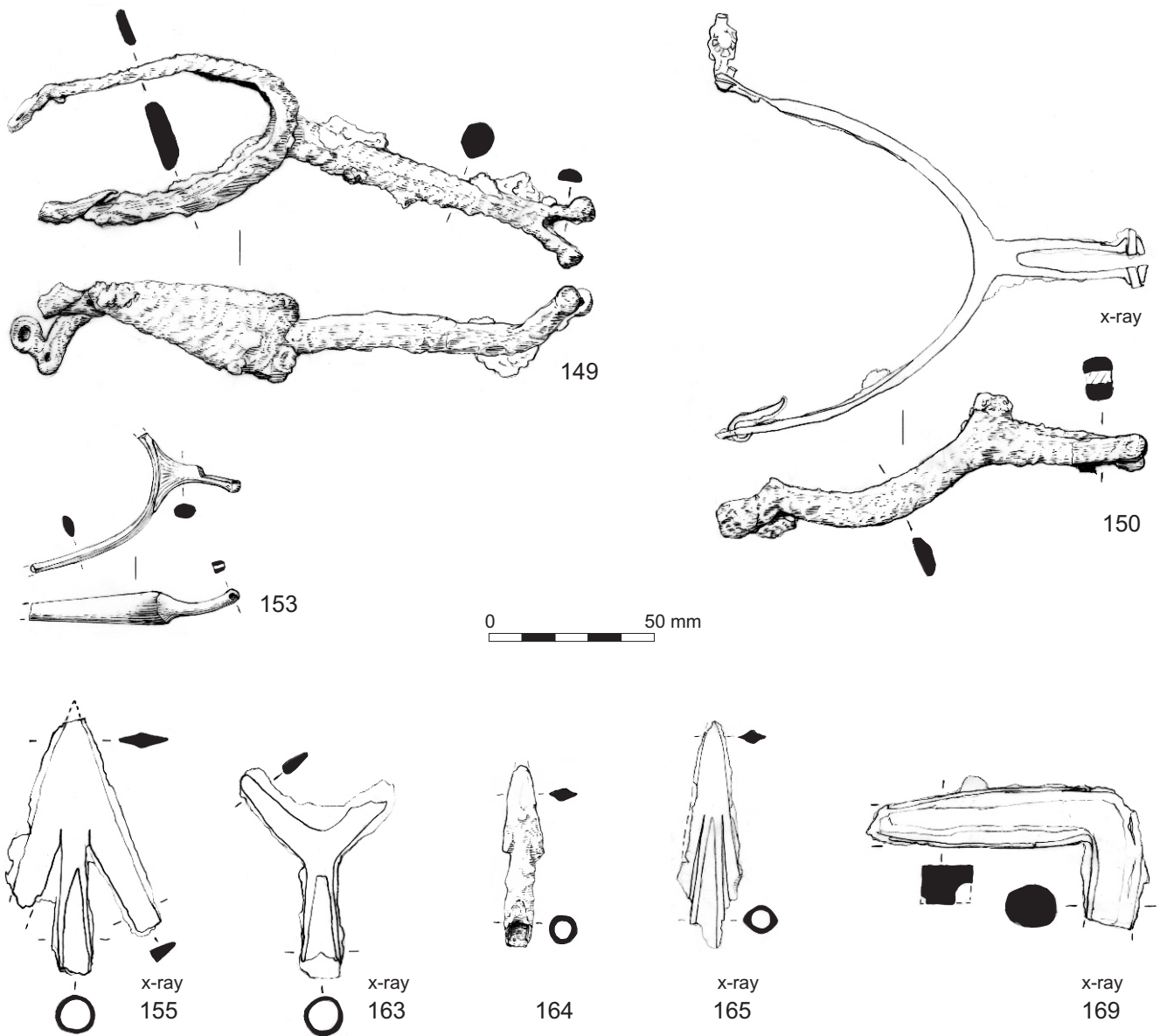

Figure 15.5: Selected metalwork (details in the catalogue)







*Framework  
Archaeology*

**BAA** Stansted London 