

# A Guide to the Classification of Medieval Ceramic Forms

Medieval Pottery Research Group  
Occasional Paper 1



# A Guide to the Classification of Medieval Ceramic Forms

## Medieval Pottery Research Group Occasional Paper 1

First published in 1998 by the Medieval Pottery Research Group.  
Copyright © Medieval Pottery Research Group 1998.

All rights reserved. No part of this publication may be reproduced, stored in a retrieval system, or transmitted, in any form or by any means, electronic, mechanical, photocopying, recording or otherwise, without the prior permission in writing of the Medieval Pottery Research Group. Within the UK, exceptions are allowed in respect of any fair dealing for the purpose of research or private study, or criticism or review, as permitted under the Copyright, Designs and Patents Act, 1988, or in the case of reprographic reproduction in accordance with the terms of the licenses issued by the Copyright Licensing Agency. Enquiries concerning reproduction outside these terms or in other countries should be sent to MPRG.

British Library Cataloguing in Publication Data available.

ISBN 0-9506105 2 6

The Medieval Pottery Research Group is a Registered Charity, No. 1018513

The publishers acknowledge with gratitude a grant from English Heritage for the publication of this volume, and a further grant in 2019 from Historic England towards the preparation of the digitised version.

## Acknowledgements

The Guide is the combined effort of many members of the Medieval Pottery Research Group (MPRG) over a number of years. It has been produced and published with the aid of English Heritage grants to Wessex Archaeology and to MPRG, for which we are most grateful. The Guide was compiled by Duncan Brown, Sarah Jennings and Lorraine Mepham; Paul Blinkhorn, Julie Edwards, Catherine Freeman, Chris Gerrard, John Hudson, John Hurst, Maureen Mellor, Charles Murray, Beverley Nenk, Jacqui Pearce, Mark Redknap, Alan Vince and Helen Walker all provided extensive comment and input at various stages; illustrations are by Jacqui Pearce and Rob Read, with Philip Magrath; members of the MPRG Editorial Committee, in particular Katherine Barclay and Barbara Hurman, undertook the editing and production stages.

The compilers acknowledge with enormous gratitude the generosity of Michael McCarthy and Catherine Brooks in allowing them extensive use of their book *Medieval Pottery in Britain AD 900-1600*.

Digitisation by Maria Geals, the text has been copy-edited and proofread by Lorraine Mepham.

Produced by:  
Medieval Pottery Research Group  
Funded by: Historic England



Funded by  
Historic England

# CONTENTS

---

## SECTION 1: INTRODUCTION

- 1.1 AIMS OF THE GUIDE
- 1.2 RECOMMENDED NAMES AND REFERENCING
- 1.3.1 REASONS FOR NEEDING A CLASSIFICATION
- 1.3.2 NOMENCLATURE
- 1.3.3 METHODOLOGY OF THE CLASSIFICATION
- 1.4 WHAT IS INCLUDED OR OMITTED
- 1.5 LIMITATIONS

## SECTION 2: USER'S GUIDE

- 2.1 CATEGORIES OF VESSEL FORM
- 2.2 HOW TO FIND YOUR WAY AROUND THE GUIDE
- 2.3 SYSTEM OF CLASSIFICATION USED
- 2.4 CONVENTIONS
- 2.5 POSSIBLE FURTHER CLASSIFICATION

## SECTION 3: JUGS, BOTTLES AND FLASKS

- 3.1 JUG
- 3.2 BOTTLE
- 3.3 FLASK

## SECTION 4: JARS

- 4.1 JAR
- 4.2 HANDLED JAR
- 4.3 PIPKIN
- 4.4 CAULDRON
- 4.5 BUNGHOLE JAR

## SECTION 5: BOWLS AND DISHES

- 5.1 BOWL
- 5.2 HANDLED BOWL
- 5.3 DISH
- 5.4 PLATE
- 5.5 FRYING PAN

## SECTION 6: DRINKING VESSELS

- 6.1 BEAKER
- 6.2 CUP
- 6.3 MUG

**SECTION 7: LIDS**

- 7.1 LID

**SECTION 8: LIGHTING AND HEATING**

- 8.1 CANDLESTICK
- 8.2 LAMP
- 8.3 LANTERN
- 8.4 WARMING PAN
- 8.5 CURFEW
- 8.6 CHAFING DISH
- 8.7 FUMING POT
- 8.8 HEATING STAND
- 8.9 BEVERAGE WARMER
- 8.10 DUTCH OVEN

**SECTION 9: INDUSTRIAL VESSELS**

- 9.1 ALEMBIC
- 9.2 ALUDEL
- 9.3 CUCURBIT
- 9.4 INDUSTRIAL BASE
- 9.5 MANTLE
- 9.6 CRUCIBLE
- 9.7 CUPEL
- 9.8 PARTING VESSEL
- 9.9 CANDLEMAKER'S TROUGH
- 9.10 SUGAR CONE MOULD
- 9.11 SYRUP-COLLECTING JAR

**SECTION 10: MISCELLANEOUS FORMS**

- 10.1 AMPHORA
- 10.2 AQUAMANILE
- 10.3 BEDPAN
- 10.4 BIRD POT
- 10.5 CHEESE PRESS
- 10.6 CHICKEN FEEDER
- 10.7 COSTREL
- 10.8 CRUET
- 10.9 DOUBLE DISH
- 10.10 FEEDING VESSEL
- 10.11 FIGURINE SALT
- 10.12 FISH SMOKER
- 10.13 FISH TRAP
- 10.14 FLOWER POT
- 10.15 GRENADE
- 10.16 HORN
- 10.17 INKWELL
- 10.18 LAVABO

- 10.19 MERCURY JAR
- 10.20 MILK CHURN
- 10.21 MONEY BOX
- 10.22 MORTAR
- 10.23 OLIVE JAR
- 10.24 RING VASE
- 10.25 RING-HANDLED VASE
- 10.26 SALT KIT
- 10.27 SPITTOON
- 10.28 URINAL
- 10.29 WATERING POT
- 10.30 WHISTLE

## SECTION 11: COMPONENT PARTS

- 11.1 BASES
- 11.2 BUNGHOLE
- 11.3 FEET
- 11.4 HANDLES
- 11.5 KNOBS including SUPPORTS
- 11.6 LUGS
- 11.7 RIMS
- 11.8 SPOUTS
- 11.9 OTHER COMPONENT PARTS

## SECTION 12: DECORATION

- 12.1 APPLIED DECORATION
- 12.2 INCISED DECORATION
- 12.3 IMPRESSED/STAMPED DECORATION
- 12.4 PAINTED DECORATION
- 12.5 SLIPPED DECORATION
- 12.6 SGRAFFITO DECORATION

## SECTION 13: MANUFACTURE AND SURFACE TREATMENT

- 13.1 CLAY PREPARATION AND FORMING
- 13.2 SURFACE MODIFICATION
- 13.3 FIRING OF VESSELS
- 13.4 POST-FIRING MODIFICATION AND EVIDENCE OF USE

## SECTION 14: BIBLIOGRAPHY

## APPENDIX I: FURTHER CLASSIFICATION OF PROFILES: AN EXAMPLE

- INDICES      Alphabetical Index  
                 Alternative Form Names

## MEDIEVAL CERAMIC FORMS: PROPOSAL FOR A NEW ENTRY

## SECTION 1: INTRODUCTION

---

### 1.1 AIMS OF THE GUIDE

The aims of this Guide are:-

- to present as extensive a range as possible of both basic and more unusual ceramic forms
- to provide a recommended name for each form
- to provide a foundation on to which regional and local variations can be added
- to give a list of alternative names previously used
- to provide a terminology for vessel parts, decoration and manufacture

This approach has two objectives, to enable practitioners to identify vessel forms, and to move towards a standard nomenclature.

The Guide does NOT attempt to cover every variation of all medieval ceramic forms ever made, many of which can have a very limited local distribution.

### 1.2 RECOMMENDED NAMES AND REFERENCING

It is strongly urged that Recommended Names, and not alternative or local names, are used in all future ceramic reports. For clarity it should be stated in each report that the nomenclature used is that given in this Guide which should be cited in the following way:-

MPRG, 1998 *A Guide to the Classification of Medieval Ceramic Forms* Medieval Pottery Research Group, Occasional Paper 1, London.

#### 1.3.1 REASONS FOR NEEDING A CLASSIFICATION

It is possible to make malleable unfired clay into virtually any shape and then fire it so that the shape is retained forever. In Britain clay has been used for over 5000 years to produce a variety of forms or shapes, usually for an essentially practical purpose but also, occasionally, for recreational or even purely ornamental reasons. Once ceramics became a component of archaeological reports the need arose to attach names to different forms as a means of identifying them. Many of these names have no precise definition and some are often used by individual practitioners to identify very different shapes.

This Guide offers a definition and nomenclature for ceramic forms made between the end of the Roman era and the beginning of intensive industrial production of the 17th century onwards, and attempts to standardise and clarify the definitions in common usage.

#### 1.3.2 NOMENCLATURE

The Guide does not attempt to define the function of most forms, nor does it suggest to what use vessels were put. However, many of the names given to specific vessel forms implicitly suggest a function, for example, candlestick. The name of a vessel form need not relate to its use or function as any basic form can have a large number of uses, although some forms are obviously much more suited to certain uses than others. It is difficult to envisage a shallow form being used for holding and pouring liquids; simple closed forms can be used for a multitude of functions such as funerary urns, urinals or for cooking. The range of uses or functions of any basic form can also be increased by the addition of component parts such as spouts and handles.

Under the system of form classification put forward in the Guide, the attributes of size and height are considered secondary to the principal defining characteristic of shape or profile. In some areas of Britain a jar form can remain exactly the same in profile but vary considerably in size and therefore capacity; thus it would simply be a smaller or larger version of the same form classification, but might previously have been given different local names.

This principle has been adhered to for the three largest sections, Jugs, Bottles and Flasks (3), Jars (4), and Bowls and Dishes (5). For ease of use, certain forms have, however, been grouped together by function, for example, Lamps, Lanterns and Candlesticks under Lighting and Heating (Section 8).

By adopting the recommended nomenclature for vessel forms and their component parts, authors of ceramic reports will establish a common terminology which will be understood by all without the need for detailed descriptions, drawings, or frequent references.

### 1.3.3 METHODOLOGY OF THE CLASSIFICATION

This Guide starts with the premise that there are certain basic forms or shapes to which can be added a variety of component parts, such as differently shaped rims, handles, spouts and so forth. Although these component parts can and do vary quite considerably, and may even change the function of a vessel, their addition does not alter the basic form or shape of say, a hemispherical or cylindrical bowl.

The first sections of the Guide cover the three main vessel forms. Inevitably there will be rare exceptions but the definitions given below form the basis for most vessels made from the end of the Roman period onwards:

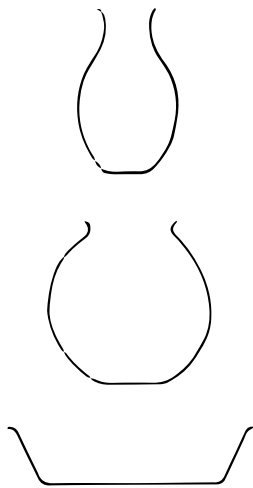

- a. tall closed wares where the diameter of both the opening and the maximum girth are smaller than the overall height. (Section 3: Jugs, Bottles and Flasks).
- b. closed wares where the maximum girth/diameter is more or less the same as the height, but the diameter of the opening is smaller than either. (Section 4: Jars).
- c. open wares where the diameter at the rim is greater than both the maximum girth and the height. (Section 5: Bowls and Dishes).

## 1.4 WHAT IS INCLUDED OR OMITTED

**Forms:** the Guide covers basic forms of ceramic vessels and equipment used for domestic, industrial, medical and recreational purposes on the British mainland. It does not attempt to cover all regional variations, those are for the individual user to add. Only the more common Continental forms found in Britain are included; many of the more specialised forms of tin-glazed earthenware, Continental and English stonewares are not included, as these come under the category of industrial or factory produced wares.

Other Sections include:

**Component Parts** (Section 11): defines the terminology to be used for rims, bases and elements that are added to vessels such as handles and bungholes.

**Decoration** (Section 12): decorative techniques are described, but not motifs and styles.

**Manufacture and Surface Treatment** (Section 13): a glossary of terms.

**Bibliography** (Section 14).

**Indices.**

The format of the Guide allows for future additions. The Guide does not cover ceramic building materials, items made of clay used in the production of clay vessels such as kiln props and saggars, moulds for metal working, or objects such as loom weights or spindle whorls. Objects or secondary vessels that have been created by utilising or adapting vessels after they have been fired are not covered here.

## 1.5 LIMITATIONS

As the title suggests, this is a Guide. It cannot and is not intended to be the answer to all problems of classification, nor will it provide names for everything. It is an aid towards a standard method of classification and a standard nomenclature.

There is a conflict between absolute logic and ease of use; the compilers have opted for ease of use after extensive consultations but undoubtedly there will be criticisms of the order and divisions arrived at. This is inevitable and attempts to satisfy all such comments have unfortunately held up other endeavours to publish a guide to forms. The original hard copy version of this Guide was produced in loose-leaf format, hence the lack of page numbers. Reference to it should be by form number, or by text section.

It is obviously impossible to have an example of every vessel form given the immense variability around the country, and there has been no attempt to do so. What is given in the Guide is a stylised 'classic' example, but there will be some variations either side of this. Some forms merge into others, and it can often be difficult to decide exactly which way to classify a particular vessel, or part of a vessel. This must be left to the individual using the Guide, and based on knowledge of their local ceramics. The same solutions apply both to complete profiles and to fragments of vessels.



## SECTION 2: USER'S GUIDE

---

### 2.1 CATEGORIES OF VESSEL FORM

The Guide begins with tall, narrow, closed forms and follows through to shallow open forms in three main sections comprising Jugs, Bottles and Flasks (Section 3), Jars (Section 4) and Bowls and Dishes (Section 5). There are then four shorter sections dealing with Drinking Vessels (Section 6), Lids (Section 7), Lighting and Heating (Section 8) and Industrial Vessels (Section 9). Miscellaneous Forms (Section 10) covers forms or shapes which do not fit into the progression from tall, narrow, closed forms to shallow, open forms, such as Aquamaniles; or vessels with names that define function as well as form, such as Cruet. In the case of a form such as Cruet which could also be classified under Jugs, there are cross-references in each section.

Section 10, Miscellaneous Forms, is probably the most incomplete, for the imagination and skill of the medieval potter resulted in a seemingly endless range of vessel types. The Medieval Pottery Research Group wish to publish occasional supplements of additional forms; information on how to propose material for inclusion is given on the final page.

The Guide is not always completely logical; some vessel forms are not in their logically appropriate sections. Amphorae and Olive Jars, for example, are in Miscellaneous Forms (Section 10) rather than being part of Jugs, Bottles and Flasks (Section 3); a specific kind of small jar is classed as a Mercury Jar and it too is in Miscellaneous Forms rather than in Jars (Section 4).

There is also a degree of overlap between some forms. Wide-mouthed, shallow jars, for example, can in some instances also be thought of as deep bowls; in such cases local traditions will probably determine whether a jar form or a bowl form is the origin for that shape.

### 2.2 HOW TO FIND YOUR WAY AROUND THE GUIDE

Use the Guide to identify a vessel form by either

- a) establishing the ratio of height to rim to maximum diameter (see 1.3.3) and looking through the forms in the appropriate section, or
- b) looking up a vessel name in the indices.

The range of names given to vessels of the same form can be extensive. This is particularly so in Jars (Section 4) where many of the alternative names (such as Butter Pot or Drug Jar) relate to function. The compilers have tried to include as many names as possible in the index, so that even if a name is not one recommended for use, it should still be in the comprehensive alphabetical index which will refer to the appropriate form and section number.

### 2.3 SYSTEM OF CLASSIFICATION USED

#### 2.3.1 Basic Forms

Each of the three basic forms, Jug (Section 3), Jar (Section 4) and Bowl (Section 5) is classified by both profile and proportion. The introduction to each section describes those two systems, together with any further subdivisions that might be used (for example vessel depth – for Bowls, shallow, medium and deep are proposed).

Every type of **profile** so far defined (for example *biconical*, *carinated*, *flared*) is described further on a separate sheet, which also gives the Recommended Name and any Alternative Names that have previously been used. Each profile is illustrated with a stylised 'standard' example (labelled a) with one or more actual examples to show the range of types which are known to occur. Where possible these have been selected from different places. It is the availability or existence of such examples that has determined the quantity and/or variety of examples given.

### 2.3.2 Adaptation of the basic form

Basic forms can be altered considerably by the addition of component parts such as *handles*, *spouts* or *feet*. In Section 11, Component Parts, there are stylised drawings of each of the three basic forms, Jug, Jar and Bowl, with names for the different areas of the vessel, such as shoulder, neck and base angle. In the sections which classify the basic forms (Sections 3, 4, and 5) adapted vessels are grouped according to the type of modification. The addition of component parts may, for example, change Bowls and Dishes into Spouted Bowls (5.1.8), Handled Bowls (5.2), Divided Dishes (5.3.4) or Frying Pans (5.5). Adapted forms are also classified by profile; even if a particular example is not included, it can be named by describing both the profile and the adaptation. One such example might be Convex-sided Spouted Bowl.

Further subdivisions based on, for example, different handles, are usually determined by local and regional traditions and should be added by individual users if desired.

### 2.3.3 References to specific forms

The Recommended Name should be used to refer to the standard form, for example, Conical Jug; local or Alternative Names should only be added as secondary if really necessary. Specific illustrations should be referred to by giving the Recommended Name, the number at the top left of the page, and the letter code for that illustration; for example, the second of the two Barrel-shaped Jugs (Section 3.1.2) would be Barrel-shaped Jug 3.1.2b. **We do not recommend using a code number without a name.**

## 2.4 CONVENTIONS

### 2.4.1 Terminology and Typefaces

**Recommended Name:** The name given in this Guide at the top right-hand corner of the page for any form is the Recommended Name and should be used to describe this form in other publications.

**Alternative Name:** An Alternative Name is a name a form has previously been given, but should now only be used as a secondary name after the Recommended Name.

**Numbers:** To allow users to add more vessel forms, the pages of the Guide have not been numbered conventionally. Instead, each form has a number given in the top left-hand corner of its sheet, which indicates its section and its sub-section. For example, Conical Jug in Section 3, sub-section 1 (Jugs), is numbered 3.1.4. For cross-reference, the name should always be used as well.

#### Typefaces

Plain **Bold** is for clarity.

*Plain Italics* are for emphasis and foreign language terms.

CAPITALS are used for cross-references to the Recommended Names of forms.

In Section 3–10, *Bold Italics* are used for cross-references to Component Parts.

### 2.4.2 Drawing conventions

Each 'standard' vessel form (labelled a for each form) is a highly stylised drawing of the shape thought to be the best representation of that form. This has been based on an actual vessel but in most cases rims are simplified and all bases are shown as flat, except when the base shape is fundamental to the definition of the form, for example, Ginger Jar and Hemispherical Bowl. Rims, handles, spouts, bases and so forth are Component Parts which may vary with region and in most cases do not alter the fundamental shape of the form in question. Wall thickness is standardised, except for forms such as Mercury Jar where it is an integral part of the form definition. These drawings are not to scale but are presented at more or less the same size on the page.

Additional examples of a form (labelled b, c, etc.) are simplified for clarity, but are of actual vessels. These drawings have been taken from many sources and redrawn by several illustrators for use here, so their scale varies, but most are at 1:6.

### 2.4.4 Bibliography (Section 14)

Bibliographic references are deliberately limited to rare forms where the reader may wish to go back to the original article. As date, source, function or fabric are not the remit of this Guide, no references have been included for the vast majority of forms or vessels.

### 2.4.3 Indices

The first index is a comprehensive alphabetical list of names and terms used in the Guide, indexed by Section number. The second is an alphabetical list of what have been denoted Alternative or subsidiary names, giving their Recommended Names and their Section number.

## 2.5 POSSIBLE FURTHER CLASSIFICATION

Although the Guide does not further subdivide the main classes of form beyond profile and modifications based on component parts, suggestions are made in Appendix I to show how this might be approached for one major form (Jars). This detailed subdivision is best undertaken at local and regional level.

## SECTION 3: JUGS, BOTTLES AND FLASKS

---

### Contents

#### Introduction to JUGS, BOTTLES and FLASKS

#### 3.1 JUG

- 3.1.1 Baluster Jug
- 3.1.2 Barrel-shaped Jug
- 3.1.3 Biconical Jug
- 3.1.4 Conical Jug
- 3.1.5 Cylindrical Jug
- 3.1.6 Globular Jug
- 3.1.7 Pear-shaped Jug
- 3.1.8 Rounded Jug
- 3.1.9 Shouldered Jug
- 3.1.10 Waisted Jug
- 3.1.11 Face Jug
- 3.1.12 Knight Jug
- 3.1.13 Puzzle Jug
- 3.1.14 Tripod Pitcher
- 3.1.15 Spouted Pitcher
- 3.1.16 *Pégau*
- 3.1.17 Bunghole Jug

#### 3.2 BOTTLE

#### 3.3 FLASK

- 3.3.1 Flattened Flask
- 3.3.2 Globular Flask
- 3.3.3 Ring Flask

#### Introduction to JUGS, BOTTLES and FLASKS

This section includes closed forms that are usually characterised by having a constricted neck and a similar height/width ratio. JUGS, BOTTLES and FLASKS are usually taller than they are wide. JARS, the other principal closed form, generally have a more even ratio of height and width, and a shorter neck (see Section 4).

JUGS, the most common of these three forms in the medieval period, are considered first and different types are classified according to their shape in profile. BOTTLES may be viewed as handle-less jugs, and it is suggested that they be classified to the same system as that used for jugs. FLASKS are classified by the shapes of the limited number of known types.

There are other less common and/or more complex narrow-necked examples in the MISCELLANEOUS SECTION (Section 10); these include COSTRELS and CRUETS.

### 3.1 JUG

**Defining characteristics:** Jugs are handled vessels designed to stand with the *rim* upright. The *handle* is a vertical loop. There may be a *lip* or *spout*. There may be more than one *handle*; such types should be termed Two-Handled Jug, Three-Handled Jug, etc.

The terms Jug and Pitcher are sometimes used interchangeably, and are rarely closely defined. On the grounds of form alone, all such vessels should be classified within the range of JUGS presented here. One defining characteristic of PITCHERS might be that they have a very short neck. This is not, however, the case for every vessel type that is termed a pitcher. While a more rigorous definition and use of these terms, therefore, would be recommended, certain forms (e.g. TRIPOD PITCHER) have a name which is so widely accepted that they are included here.

Jugs are classified on the basis of the vessel profiles of known examples, with further types that have been defined by the addition of particular components or embellishments.

**Bases** are shown flat in the stylised drawings, except for forms where a *rounded base* is an integral part of the profile, e.g. GLOBULAR JUG (3.1.6).

### 3.1 JUG

### Jug Profiles

JUGS are classified by **profile** (see below):

- 3.1.1 Baluster Jug
- 3.1.2 Barrel-shaped Jug
- 3.1.3 Biconical Jug
- 3.1.4 Conical Jug
- 3.1.5 Cylindrical Jug
- 3.1.6 Globular Jug
- 3.1.7 Pear-shaped Jug
- 3.1.8 Rounded Jug
- 3.1.9 Shouldered Jug
- 3.1.10 Waisted Jug

and can be further subdivided on the basis of *size* or *capacity* (but see Section 1.3.2)

Small jugs may be termed Drinking Jugs or MUGS (see 6.3).

For other recommended Jug names, see **Jug Proportions** overleaf.

### 3.1 JUG

### Jug Profiles

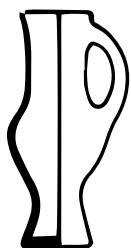

baluster

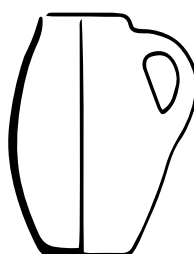

barrel-shaped

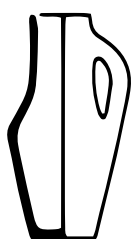

biconical



conical

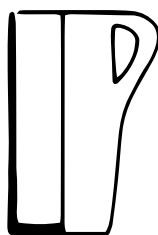

cylindrical

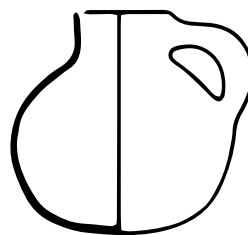

globular

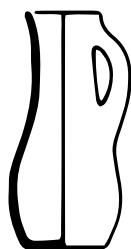

pear-shaped

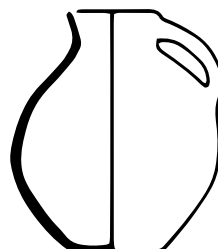

rounded

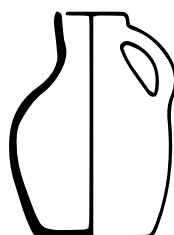

shouldered

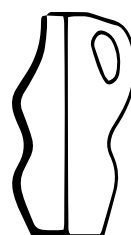

waisted

### 3.1 JUG

### Jug Proportions

JUGS can be classified by their **proportions**

**SLENDER:** where the height is at least twice the maximum diameter

**MEDIUM:** where the height is greater than but not twice the maximum diameter

**SQUAT:** where the height is less than the maximum diameter.

Certain specific Jug types have an accepted alternative nomenclature, despite the fact that they could be classified within the scheme of profiles presented here:

**3.1.16** *Pégau*

Certain JUG types may be defined by the addition of *decorative features*:

**3.1.11** **Face Jug**

**3.1.12** **Knight Jug**

JUGS may be adapted by the addition of *component parts* such as *feet* or *spouts*:

**3.1.14** **Tripod Pitcher**

**3.1.15** **Spouted Pitcher**

**3.1.17** **Bunghole Jug**

Other JUGS have particular, specialised functions:

**3.1.13** **Puzzle Jug**

see also CRUET (10.8)

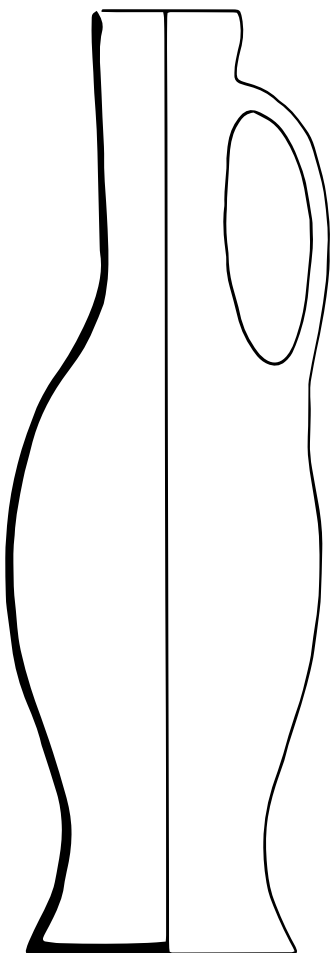

slender

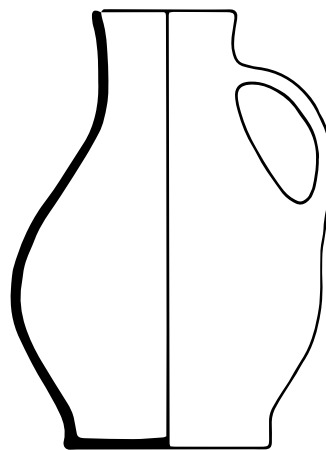

medium

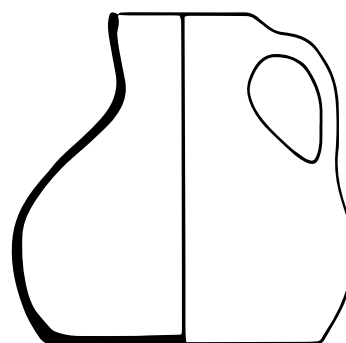

squat

### 3.1.1 JUG

#### Baluster Jug

**Defining characteristics:** A jug with a sinuous profile where the rim, girth and base are of roughly equal diameter, and the neck and lower body are narrower.

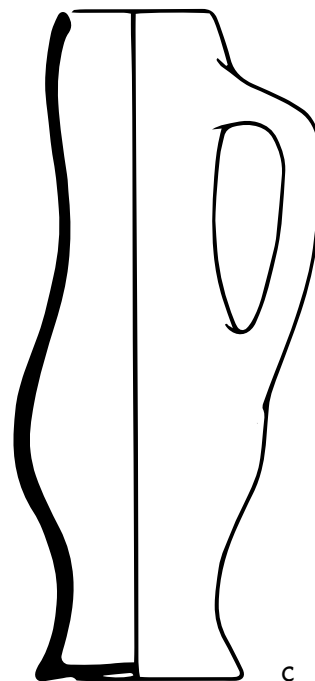
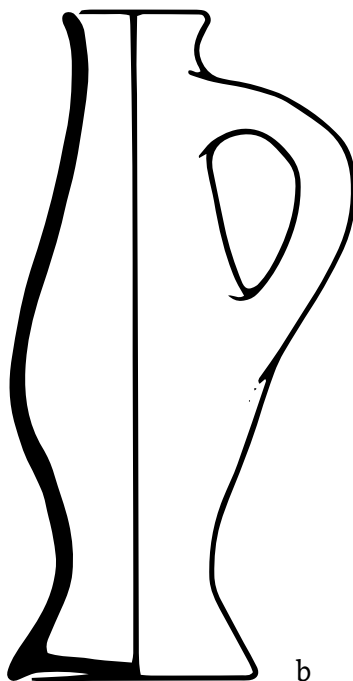
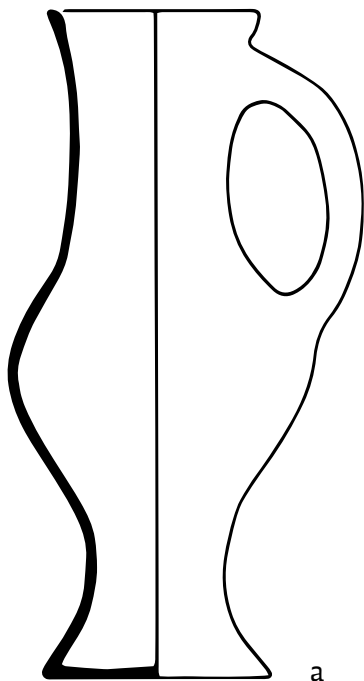

### 3.1.2 JUG

#### Barrel-shaped Jug

**Defining characteristics:** A jug with little or no discernible neck, and a profile which has an even, convex profile from rim to base, which have roughly equal diameters.

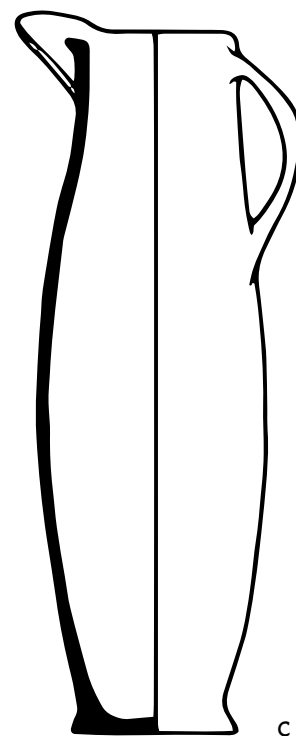
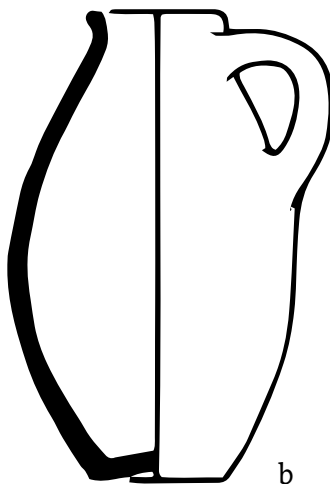
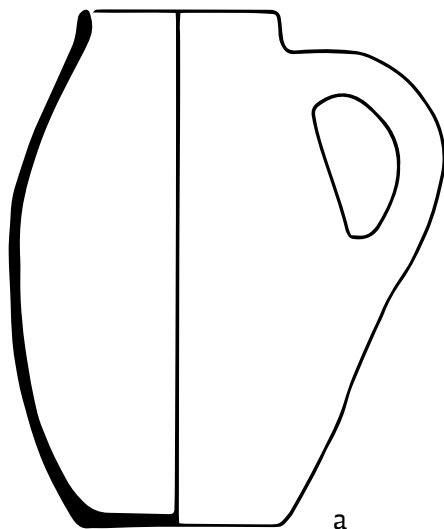



### 3.1.3 JUG

#### Biconical Jug

**Defining characteristics:** A jug with a body profile resembling two cones joined together at their widest points, producing a distinct carination.

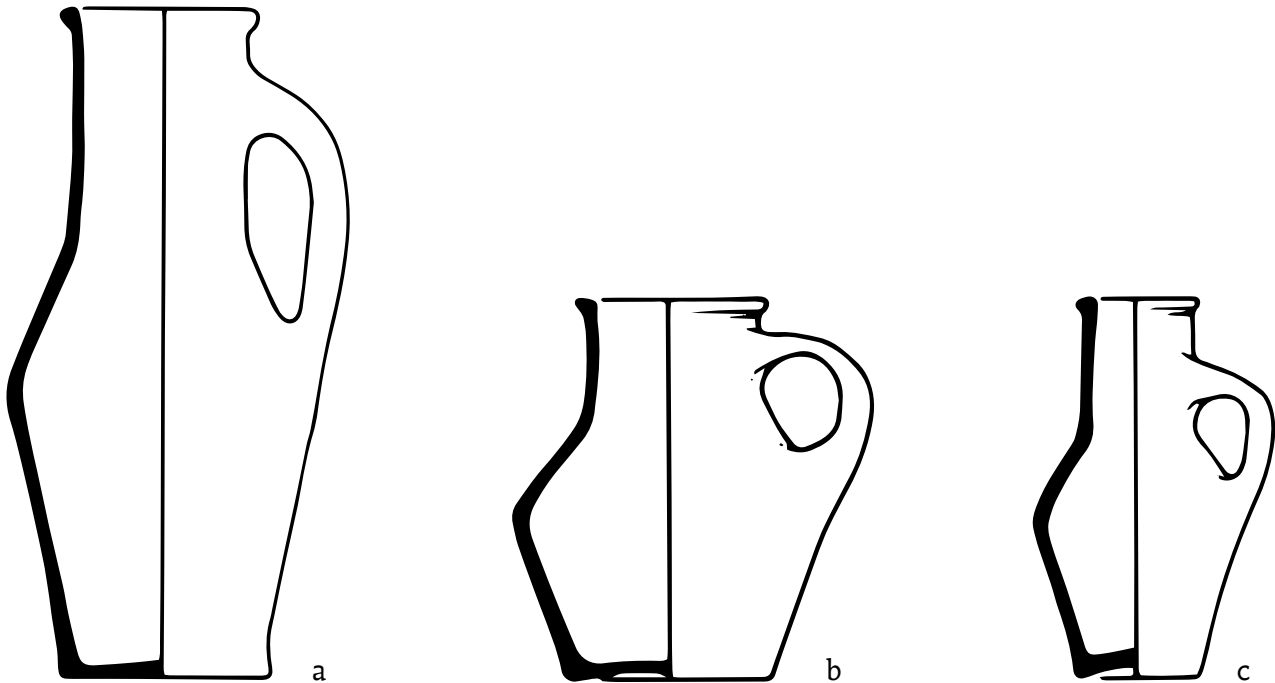

### 3.1.4 JUG

#### Conical Jug

**Defining characteristics:** A jug with more or less straight sides that flare out from a narrow rim or neck to a wider base.

**Alternative name:** Lighthouse Jug (regional: Midlands).



### 3.1.5 JUG

### Cylindrical Jug

**Defining characteristics:** A jug with straight vertical sides and roughly equal rim and base diameters.

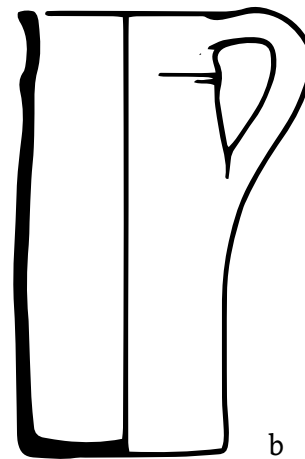
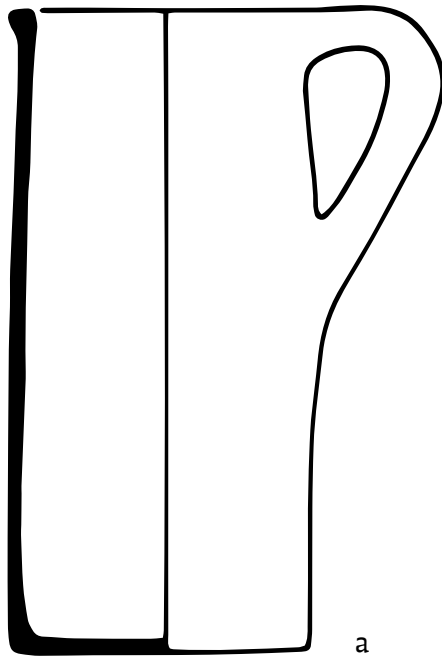

### 3.1.6 JUG

### Globular Jug

**Defining characteristics:** A jug with a rounded profile and a round base, i.e. with no discernible basal angle.

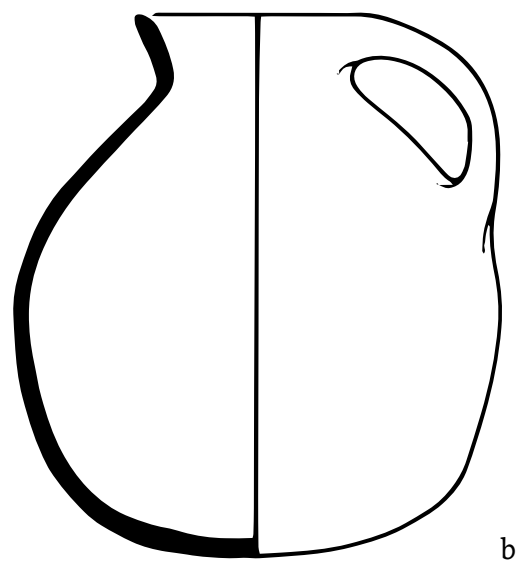
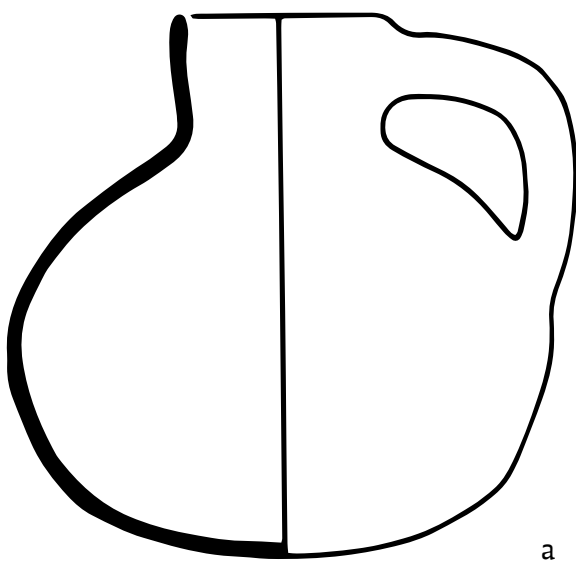

### 3.1.7 JUG

#### Pear-shaped Jug

**Defining characteristics:** A jug with a maximum diameter in the lower half of the vessel, and with no discernible shoulder.

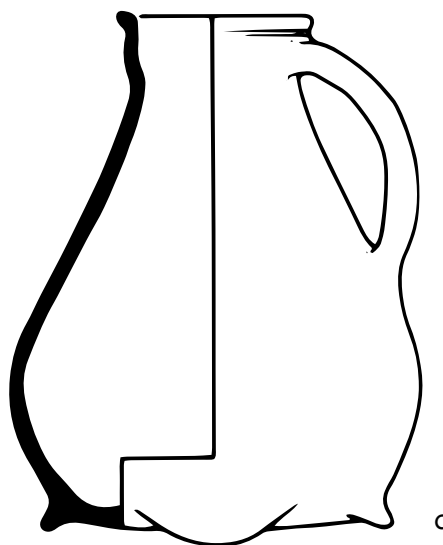
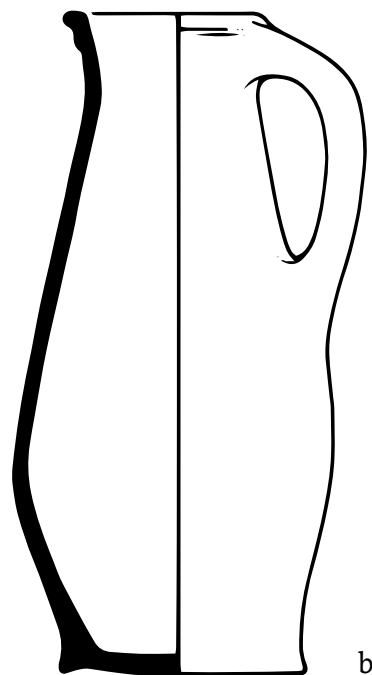

### 3.1.8 JUG

### Rounded Jug

**Defining characteristics:** A jug with an evenly rounded profile and a discernible basal angle; the maximum diameter is near the mid-point and in the upper half of the vessel.

A specific form of rounded jug is the *Pégau* (3.1.16).

**Alternative name:** a specific German stoneware form, often featuring a bearded face-mask on the neck, is termed *Bartmann*; the term *Bellarmino* is not recommended.

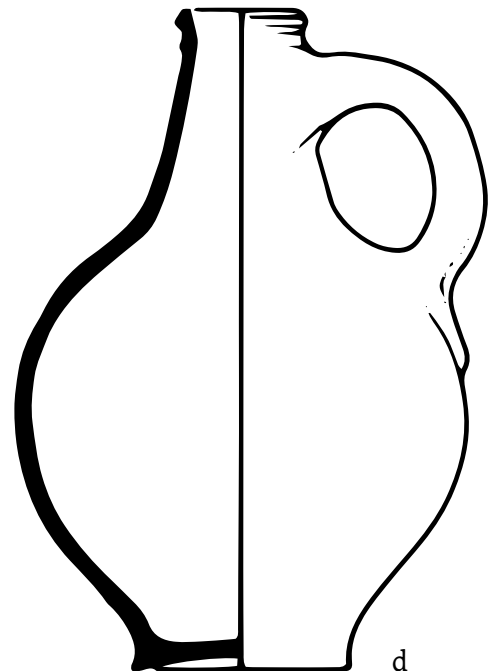
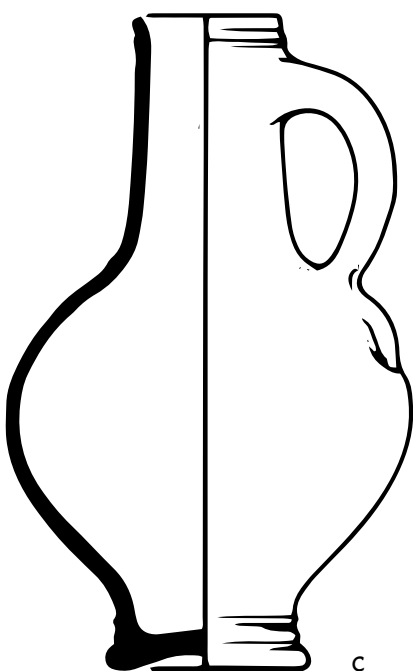
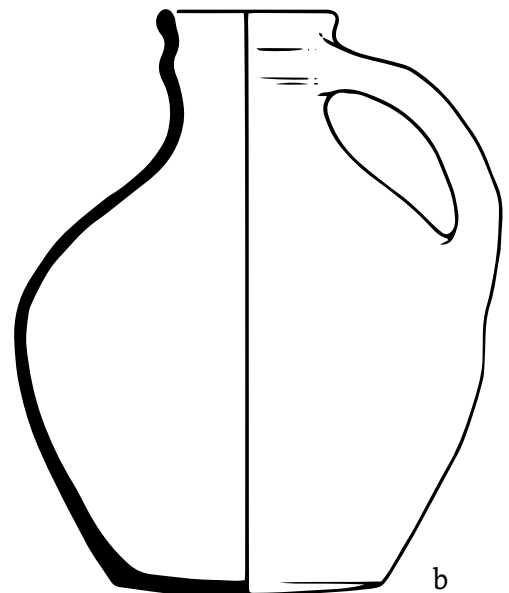
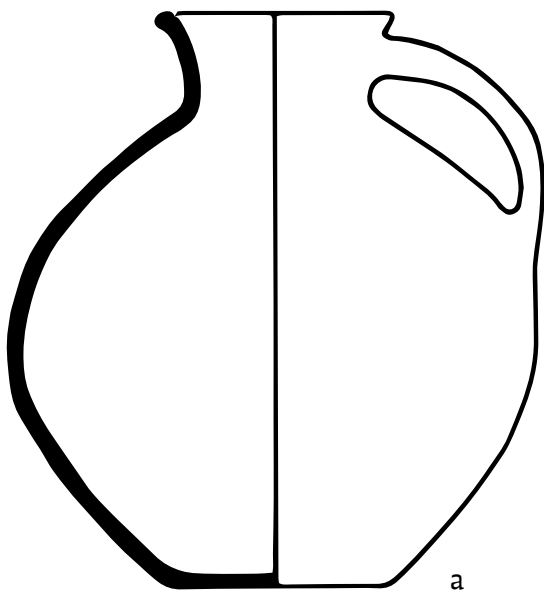

### 3.1.9 JUG

#### Shouldered Jug

**Defining characteristics:** A jug with a roughly cylindrical or slightly flaring lower body, a pronounced inward-sloping shoulder and marked neck/body angle.

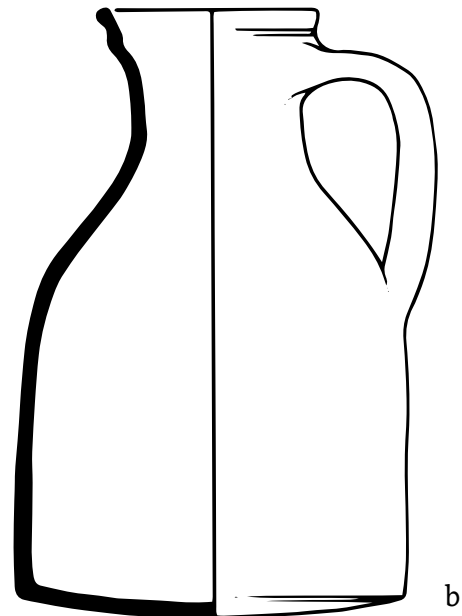
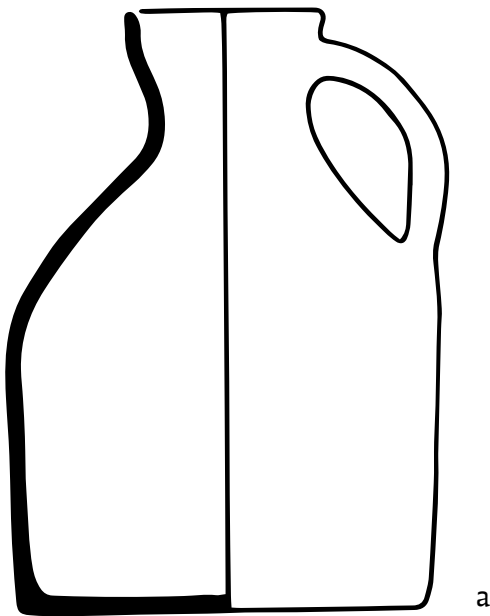

### 3.1.10 JUG

#### Waisted Jug

**Defining characteristics:** A jug with a constriction between the upper and lower body sections.

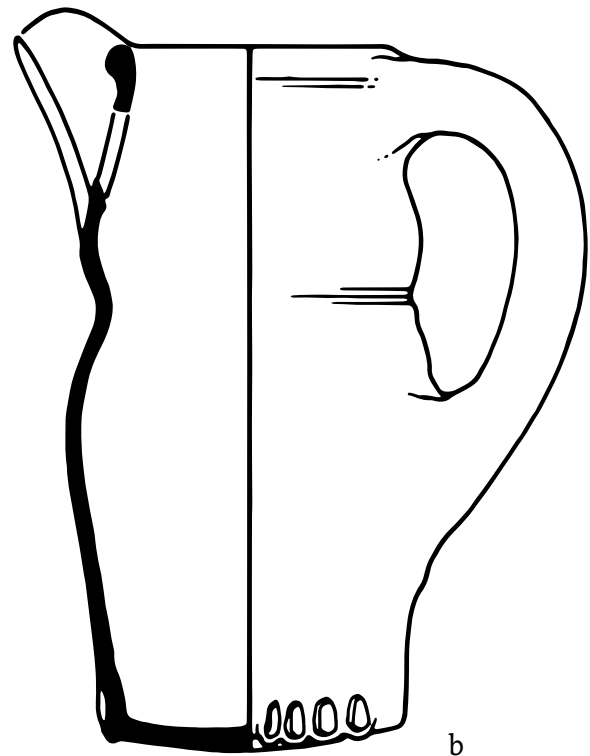
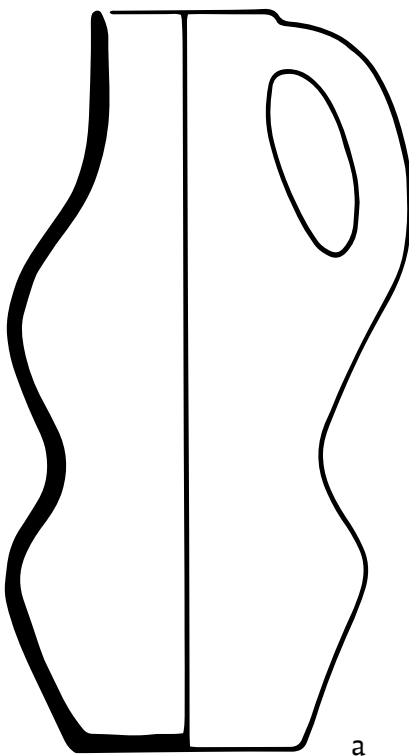

### 3.1.11 JUG

### Face Jug

**Defining characteristics:** Any type of jug with decoration representing the form of a human face or figure. The shape of the vessel forms the outline of the human face or figure. These can vary from simple and very stylized (b) to intricate faces, including eyes, ears, noses, lips and beards (c). Other body parts, such as arms and hands, may be represented, as well as items of dress, such as belts and buckles (d). There are occasional phallic variants. These elements are formed by a combination of applied and impressed or incised decoration. Profiles can vary and should be classified in the same way as the basic JUG form (see 3.1.1-3.1.10).

**Alternative name:** Anthropomorphic Jug.

A jug including animal rather than human elements is termed a Zoomorphic Jug.

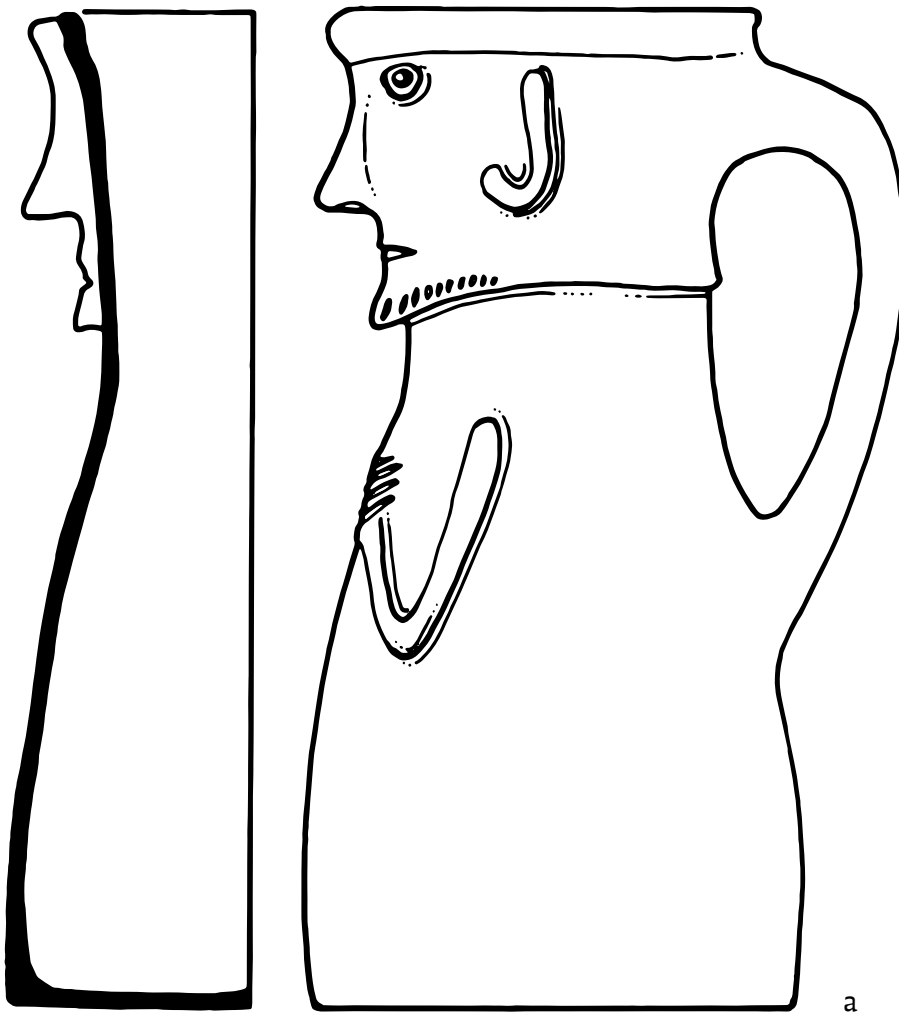

### 3.1.11 JUG

### Face Jug

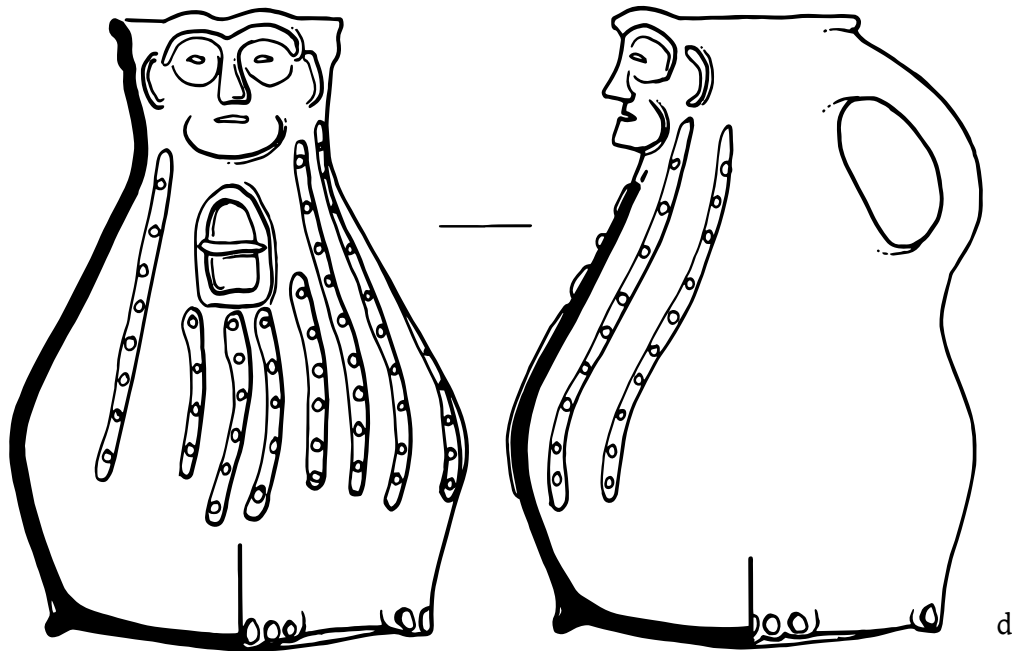
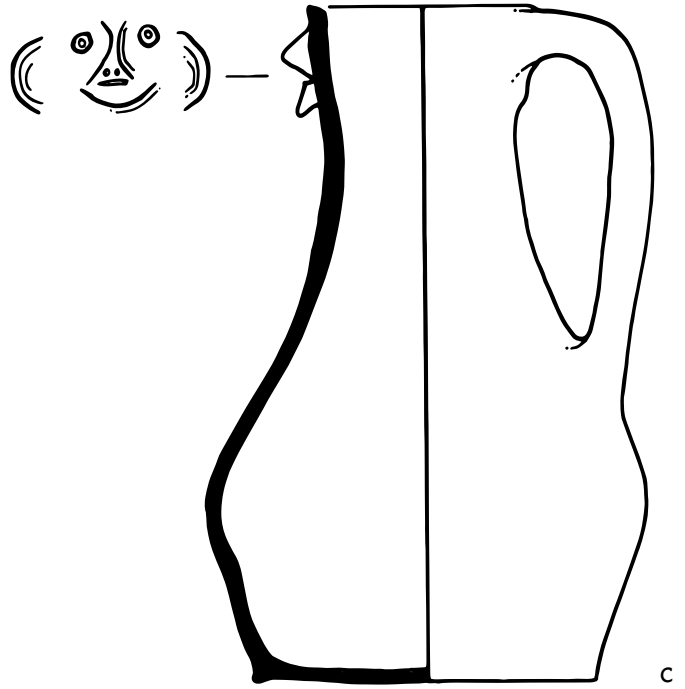
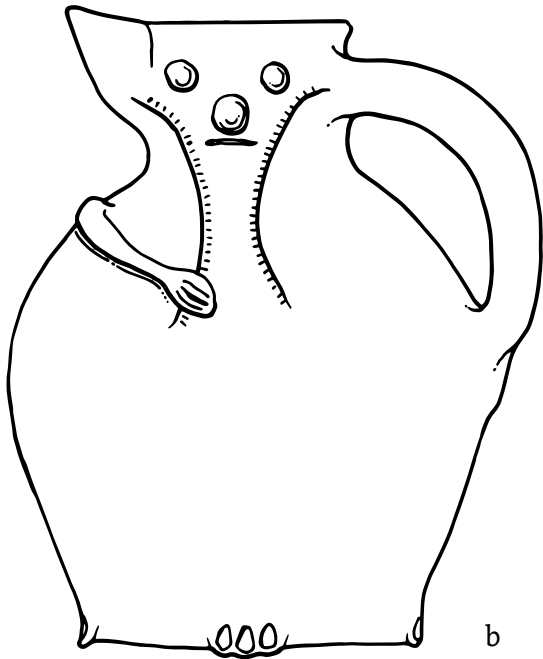

### 3.1.12 JUG

### Knight Jug

**Defining characteristics:** A type of jug decorated with applied figures in the form of knights in armour. Knight jugs are among the most elaborately decorated pottery vessels made in medieval England. Profiles can vary and should be classified in the same way as the basic JUG form (see 3.1.1-3.1.10).

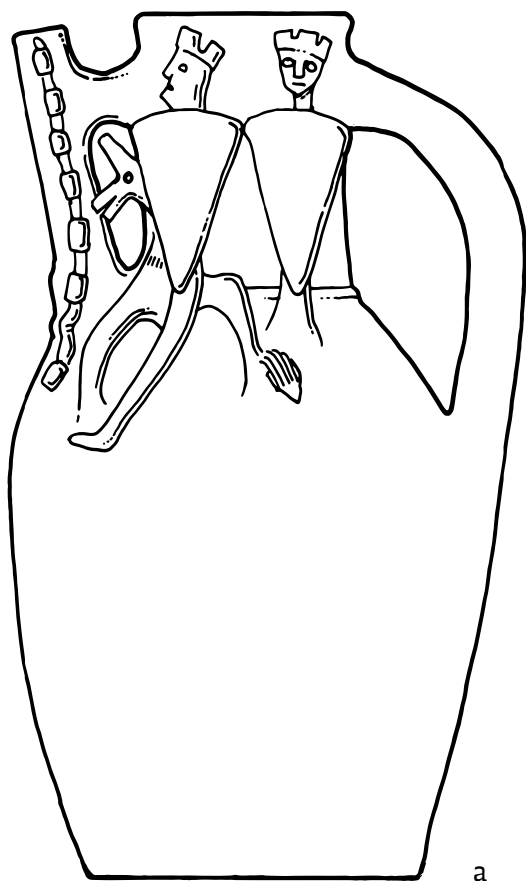



### 3.1.13 JUG

### Puzzle Jug

**Defining characteristics:** A form of jug that constitutes a practical joke or conundrum. An elaborate combination of *cut-outs* in the body and *hollow handles* and tubes render conventional use impossible. The puzzle is to work out how to empty it without spilling the liquid it contains.

There are many types of Puzzle Jug. The most common medieval types have a hollow handle leading to a lower compartment, from which liquid may be poured via the spout (b). Later types have a single internal compartment, from which the liquid must be sucked via a hollow handle through holes in the hollow rim (c). More complex variants also require 'false' outlet holes to be blocked with the fingers while sucking. Profiles can vary and should be classified in the same way as the basic JUG form (see 3.1.1-3.1.10).

There are also PUZZLE CUPS (6.2.8).

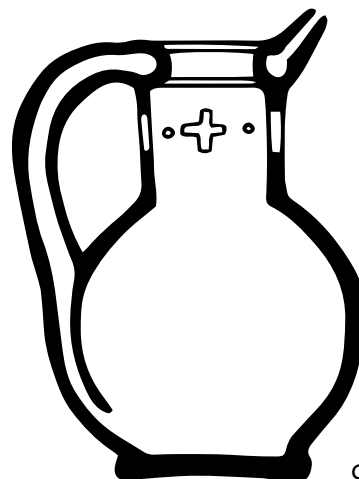
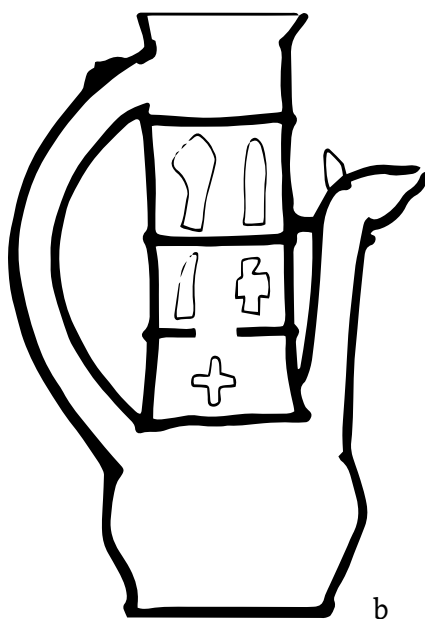
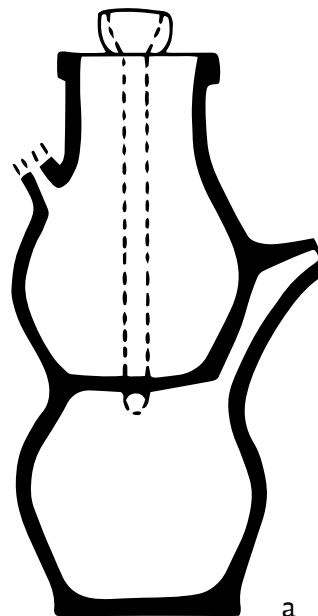
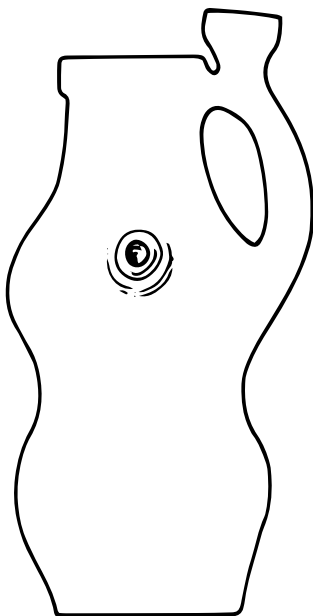

### 3.1.14 JUG

### Tripod Pitcher

**Defining characteristics:** This JUG form is characterised by the addition of three applied *feet*. The feet are usually short and stubby. There may be a *lip* or *spout*. Profiles vary and should be classified in the same way as the basic JUG form (see 3.1.1-3.1.10).

This form of jug comprises a specific form tradition prevalent in the southern part of England, mainly in the 12th and early 13th centuries.

Three-footed jugs that are outside this tradition, either geographically or chronologically, should be termed TRIPOD JUGS.

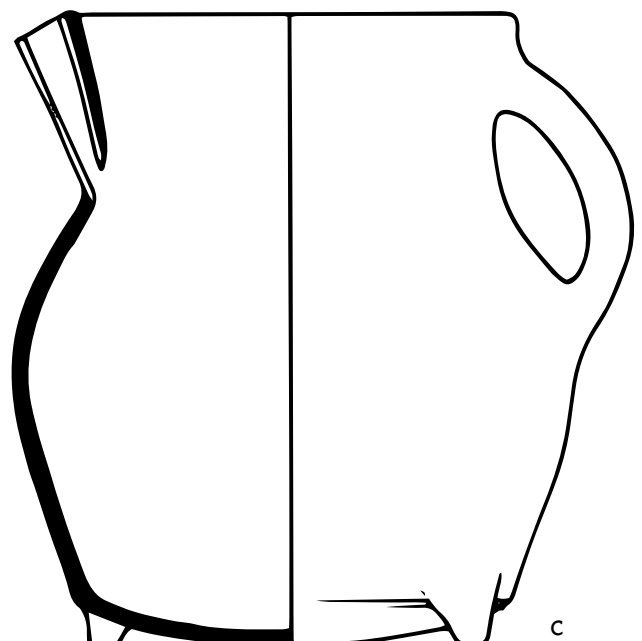
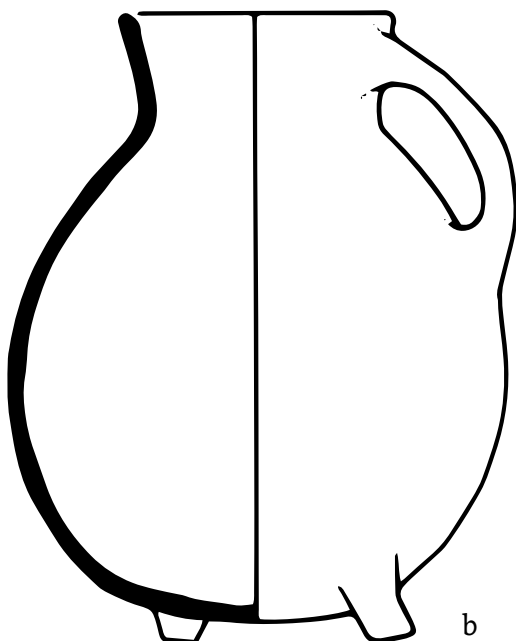
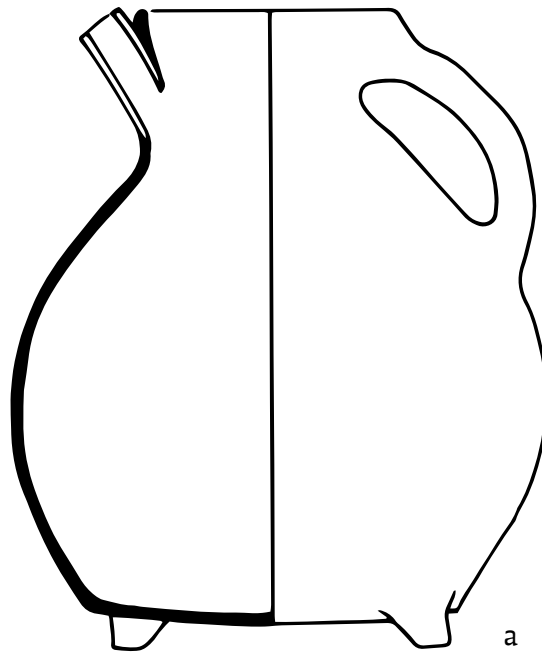

## 3.1.15 JUG

## Spouted Pitcher

**Defining characteristics:** A jug form which usually has a short, narrow neck and rim and an *applied spout*. The spout is generally tubular and either free-standing (b), or attached to the rim/neck (c, d), rising from just above the high shoulder or girth. The spout may have an additional supporting *strut* (e). Profiles vary and should be classified in the same way as the basic JUG form (see 3.1.1-3.1.10).

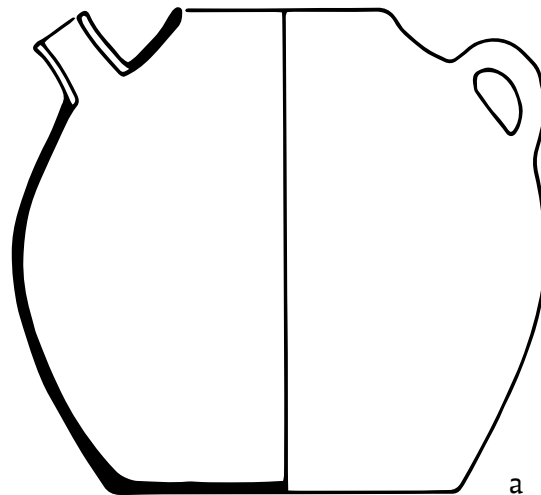

a

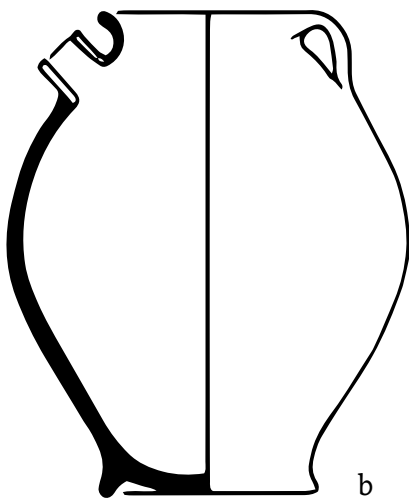

b

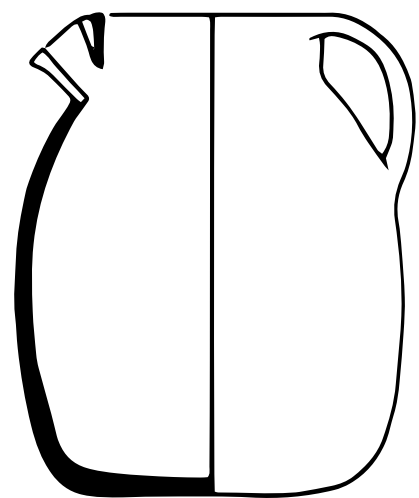

c

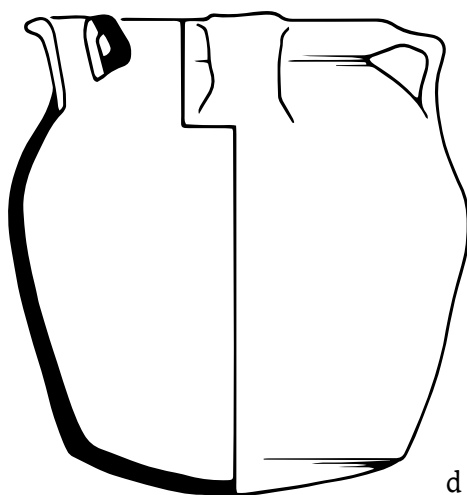

d

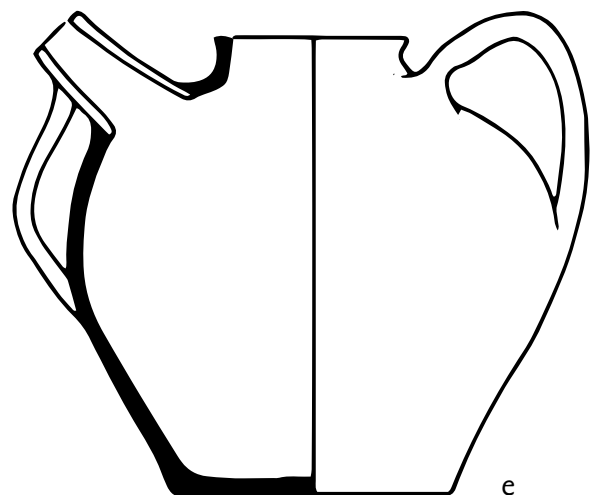

e

### 3.1.16 JUG

### *Pégau*

**Defining characteristics:** A specific form of rounded JUG with a wide mouth, a large *parrot beak spout* and three *handles*. The spout may have a *lug* applied to the outside (c). The handles are wide straps that spring from the rim to the girth.

The term *Pégau* (pl. *Pégaux*) should only be applied to products of the Saintonge potteries in the 13th and 14th centuries.

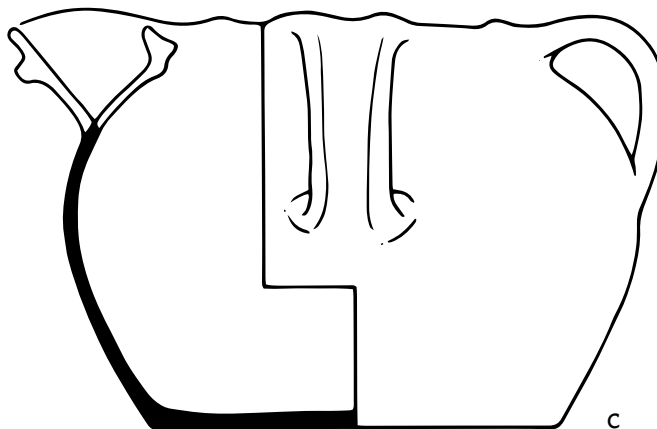
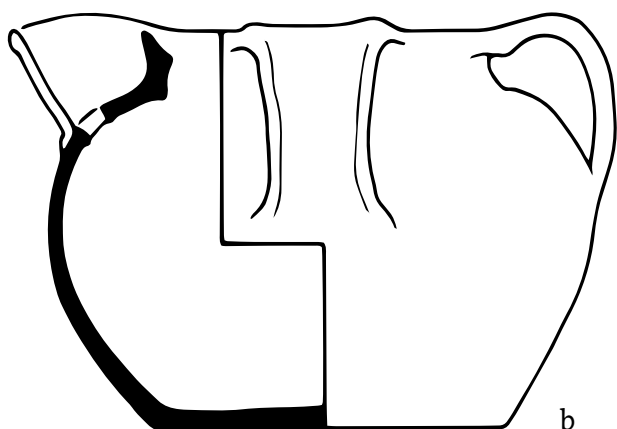
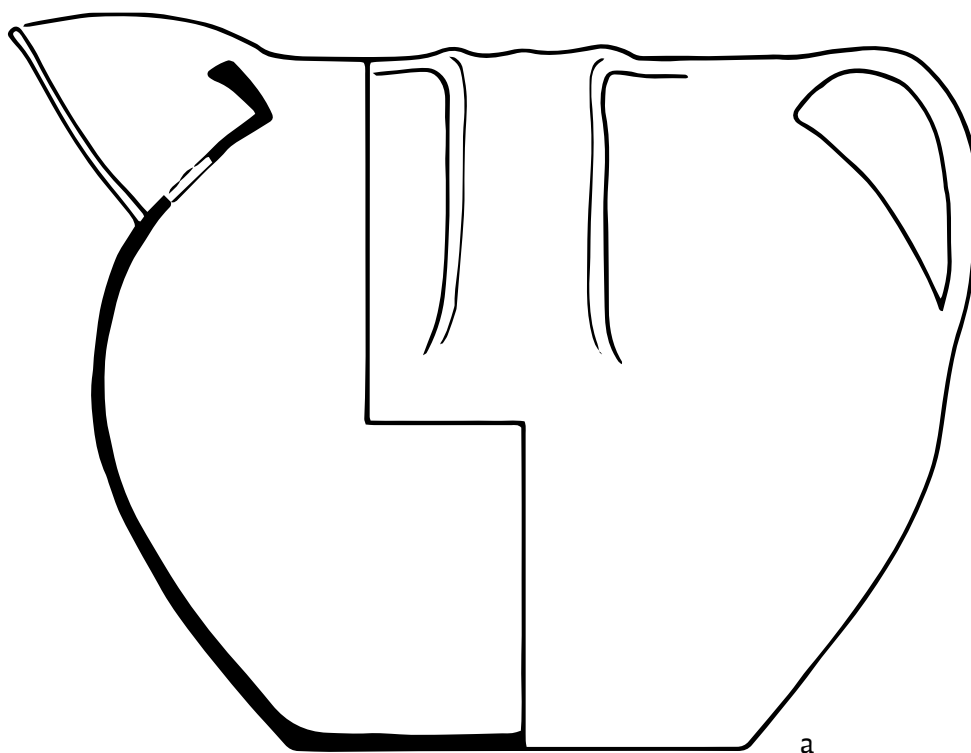

## 3.1.17 JUG

## Bunghole Jug

**Defining characteristics:** A jug with a pierced *bunghole* just above the base. The bunghole can be made through an applied knob or disc of clay, or can be simply a hole in the vessel wall. In use the bunghole would probably have held a spigot or tap employed in drawing liquid from the vessel. Profiles vary and should be classified in the same way as the basic JUG form (see 3.1.1-3.1.10).

**Alternative names:** Cistern, Bunghole Pitcher have been used.

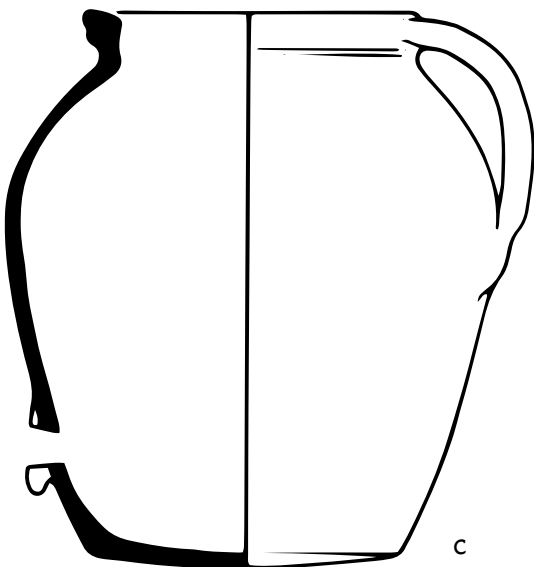
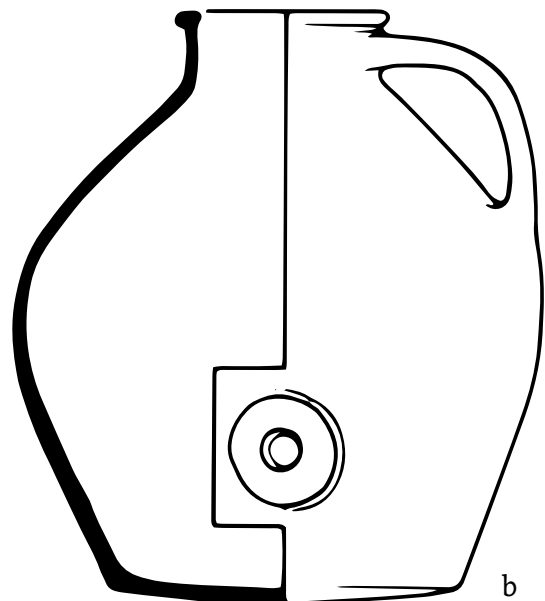
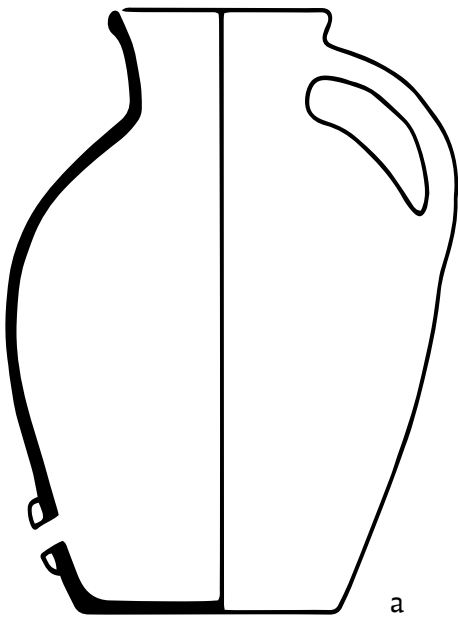

### 3.2 BOTTLE

**Defining characteristics:** A vessel with a constricted, often narrow neck and no handle, designed to stand with the neck upright. Profiles vary and should be classified in the same way as the basic JUG form (see 3.1.1-3.1.10).

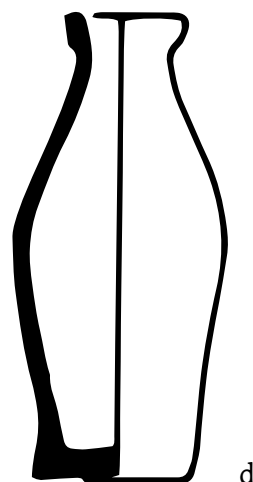
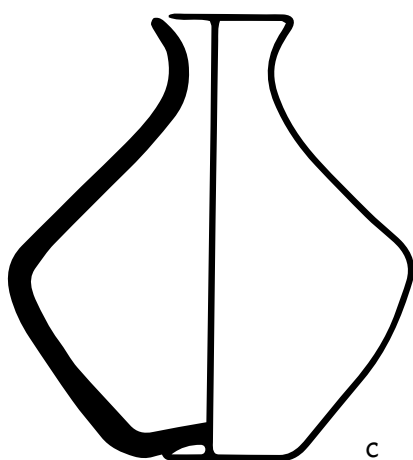
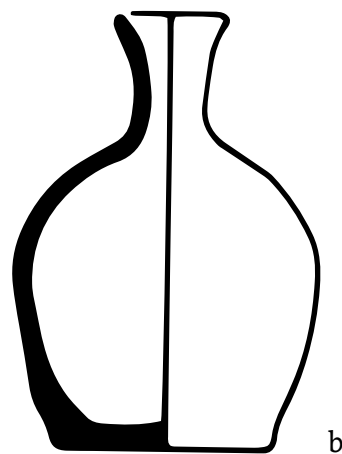
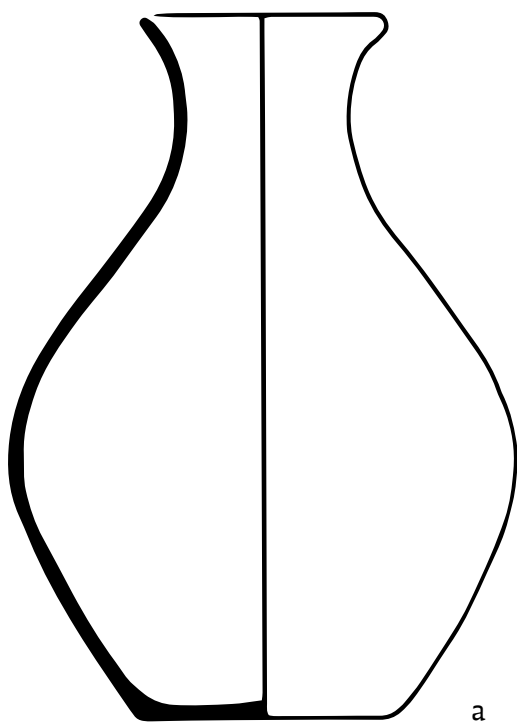

### 3.3 FLASK

**Defining characteristics:** A round-based vessel with a narrow neck and no handles, not designed to stand upright.

There are three main forms. Two were defined by Hurst (1966) when discussing Martincamp-type flasks:

**3.3.1 Flattened Flask:** A circular flask with one or two flattened faces (Hurst 1966, Type I).

**3.3.2 Globular Flask:** A flask with a rounded, almost spherical shape (Hurst 1966, Types II and III).

The third form is

**3.3.3 Ring Flask:** A flask with a hollow ring-shaped form.

**Bibliography:** Hurst 1966; Hurst *et al.* 1986, fig. 47; Freke 1979, fig. 14, no. 76.

### 3.3 FLASK

### Flask Forms

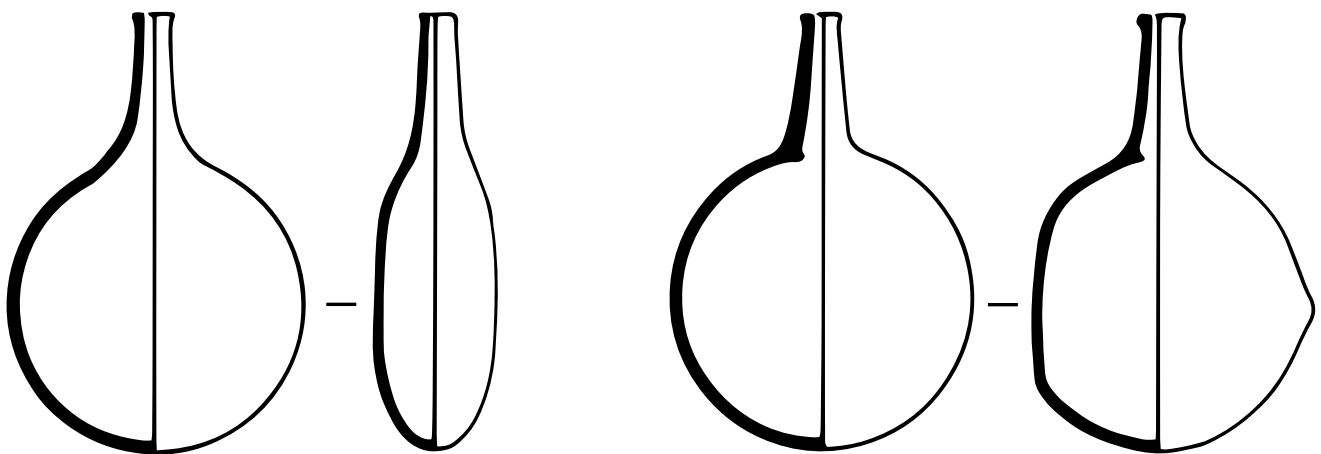

flattened flask

globular flask

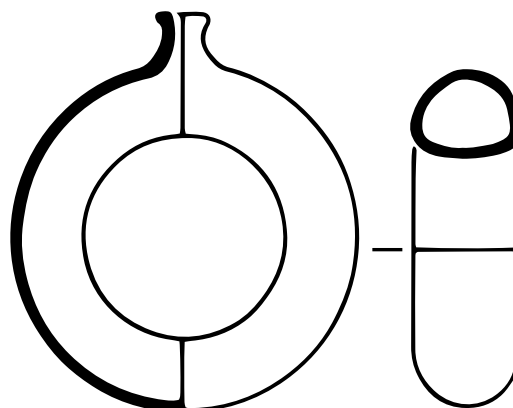

ring flask

## SECTION 4: JARS

---

### Contents

#### Introduction to JARS

- 4.1 **JAR**
  - 4.1.1 Biconical Jar
  - 4.1.2 Concave-sided Jar
  - 4.1.3 Cylindrical Jar
  - 4.1.4 Flared Jar
  - 4.1.5 Globular Jar
  - 4.1.6 Inturned Jar
  - 4.1.7 Rounded Jar
  - 4.1.8 Shouldered Jar
- 4.2 **HANDLED JAR**
  - 4.2.1 Single-handled Jar
  - 4.2.2 Basket-handled Jar
  - 4.2.3 Double-handled Jar
  - 4.2.4 Bar Lug Jar
  - 4.2.5 Bar Lip Jar
  - 4.2.6 Multi-handled Jar
- 4.3 **PIPKIN**
  - 4.3.1 Tripod Pipkin
- 4.4 **CAULDRON**
- 4.5 **BUNGHOLE JAR**

#### Introduction to JARS

This section covers the closed form JAR and the various adaptations, such as PIPKINS and CAULDRONS, that result from adding *component parts* to the basic form. It is the difference in the ratio of height to maximum width, together with a short and usually constricted neck, that distinguishes JARS from JUGS.

JARS are probably the most functionally versatile of all forms, and the addition of one or more *handles* or *feet* extends the range of uses even further.

The range of names used for jar forms is probably the most extensive of any of the three main categories of forms. Many of these names have a functional implication, e.g. Cooking Pot, Honey Pot, Chamber Pot, Funerary Urn and Drug Jar; many of them are also either period- or region- oriented. Probably the most confusing and contentious name commonly given to jar forms is that of Cooking Pot.

A system for classifying the basic jar shapes is given here, together with proposed names for the forms which result from the addition of component parts.



## 4.1 JAR

**Defining characteristics:** The term JAR is given to a closed form which falls midway between JUGS and BOWLS/DISHES, but as a general class of vessel is less easy to define strictly. JARS have a more even width to height ratio than either JUGS or BOWLS/DISHES. Generally, they have a wide neck opening, a short neck/rim with a marked constriction at the neck and a base smaller than the maximum diameter. There are, however, exceptions to this definition which are still classed as jar, e.g. Inturned Jar (4.1.6).

There may be some overlap between JARS and BOWLS, particularly when the height of a vessel is noticeably less than the maximum diameter. Such vessels could be classified as squat or shallow jars, or as bowls. For this reason some vessel shapes appear in both this section and in BOWLS (Section 5).

The jar form is frequently called a Cooking Pot, a term which has a specific functional implication. While it is undoubtedly true that many of these vessels were used for cooking, a simple utilitarian form might also have been used for a multitude of other functions, which could have changed during the life of the vessel. The term JAR, therefore, is recommended in order to avoid possibly spurious functional connotation and the term Cooking Pot should be used only for vessels that show evidence for cooking in the form of sooting and burnt residues.

A wide variety of shapes and proportions are represented by the jar form. For this reason a suggested scheme is given, to be followed if a more extensive and detailed level of classification is required (see Appendix 1).

Bases are shown flat in the stylised drawings, except for forms where a *rounded base* is an integral part of the profile, e.g. GLOBULAR JAR (4.1.5).

## 4.1 JAR

## Jar Profiles

JARS are classified by **profile** (see below):

- 4.1.1 Biconical Jar
- 4.1.2 Concave-sided Jar
- 4.1.3 Cylindrical Jar
- 4.1.4 Flared Jar
- 4.1.5 Globular Jar
- 4.1.6 Inturned Jar
- 4.1.7 Rounded Jar
- 4.1.8 Shouldered Jar

and can be further subdivided on the basis of *size* or *capacity* (see Appendix 1, but also Section 1.3.2). Large jars may be called Storage Jars. Small jars may be called BEAKERS (see 6.1).

## 4.1 JAR

## Jar Profiles

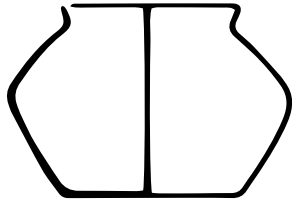

biconical

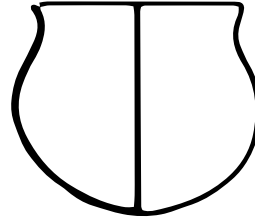

globular

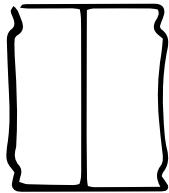

concave-sided

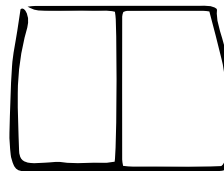

inturned

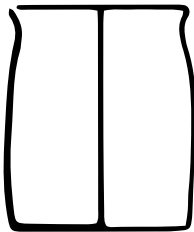

cylindrical

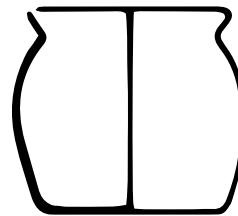

rounded

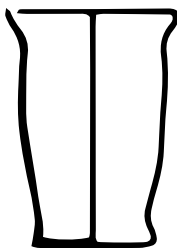

flared

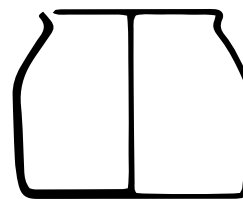

shouldered

## 4.1 JAR

## Jar Proportions

JARS can also be classified by their **proportions** (see below):

NARROW: maximum diameter less than height

MEDIUM: maximum diameter same as height

WIDE: maximum diameter more than height

Wide jars, particularly those with a less well-defined neck constriction and with vessel walls either upright (4.1.3 Cylindrical Jar) or flaring (4.1.4 Flared Jar), may fall into the category of BOWLS (see 5.1.1-5.1.7).

Jars adapted by the addition of *component parts*, such as one or more *handles* and/or *feet* are classified as follows:

4.2 Handled Jar

4.3 Pipkin

4.3.1 Tripod Pipkin

4.4 Cauldron

see also URINAL (10.28)

Some Jars have been defined on the basis of *decorative features*:

e.g. *Buckelurne*

### 4.1 JAR

### Jar Proportions

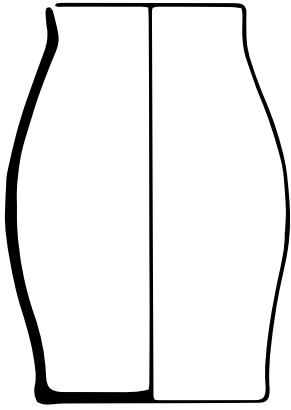

narrow

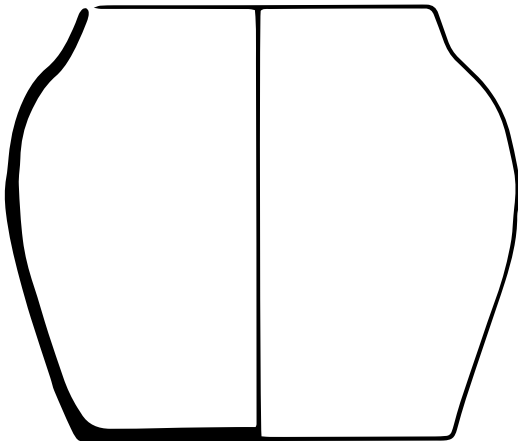
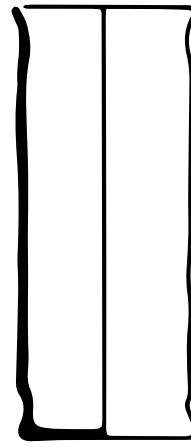

medium

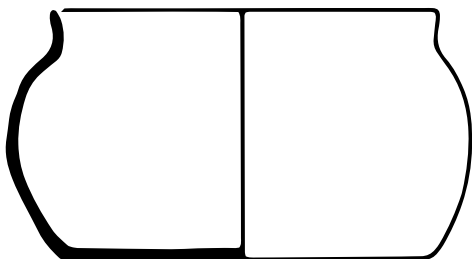
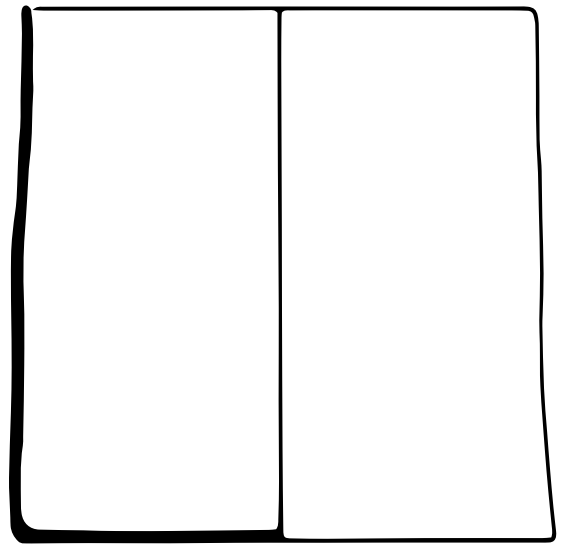

wide

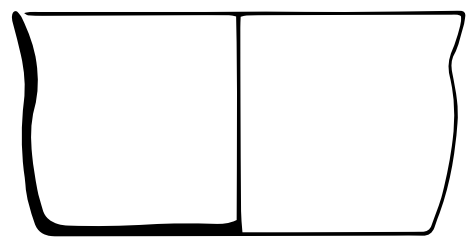

Specific JAR forms may have functional connotations:

SYRUP-COLLECTING JAR (9.11)  
MERCURY JAR (10.19)

Names which have been attributed to the basic jar shapes and sometimes indicate function include:

specific shapes:

Ginger Jar (see 4.1.5)  
OLIVE JAR or Oil Jar (see 10.23)  
Vase (see 4.1.8)

non-specific shapes:

Butter Pot  
Cooking Pot  
Honey Jar or Honey Pot  
Urn or Funerary Urn

In some parts of the country these terms have been applied to specific forms.

#### 4.1.1 JAR

#### Biconical Jar

**Defining characteristics:** A jar whose profile resembles two truncated cones joined together at the widest point, forming a carination at the centre of the vessel.

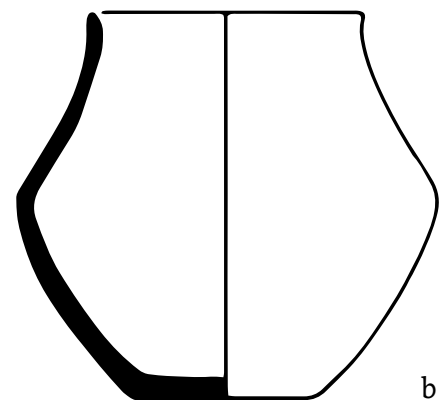
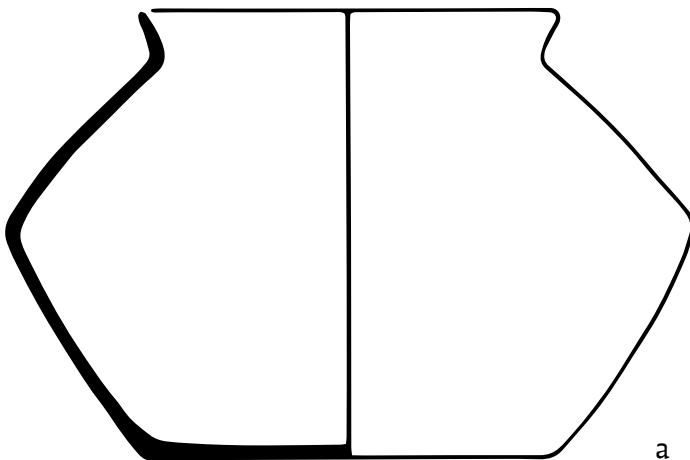

### 4.1.2 JAR

### Concave-sided Jar

**Defining characteristics:** A jar with vertical concave body walls.

**Alternative name:** *Albarelo* (pl. *Albarelli*) is used particularly for those in tin-glazed earthenware.

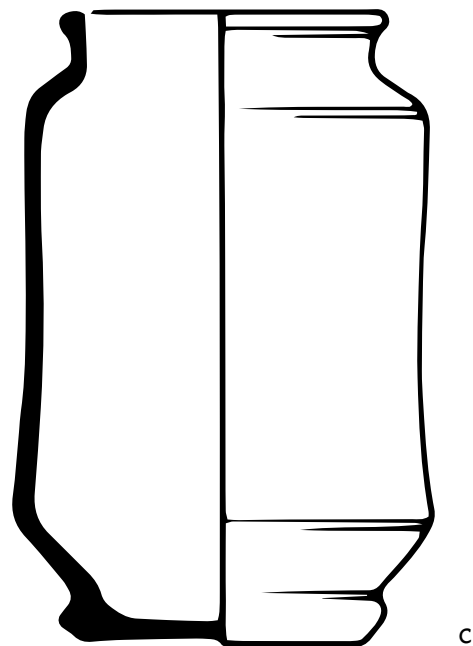
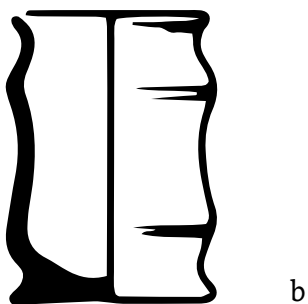
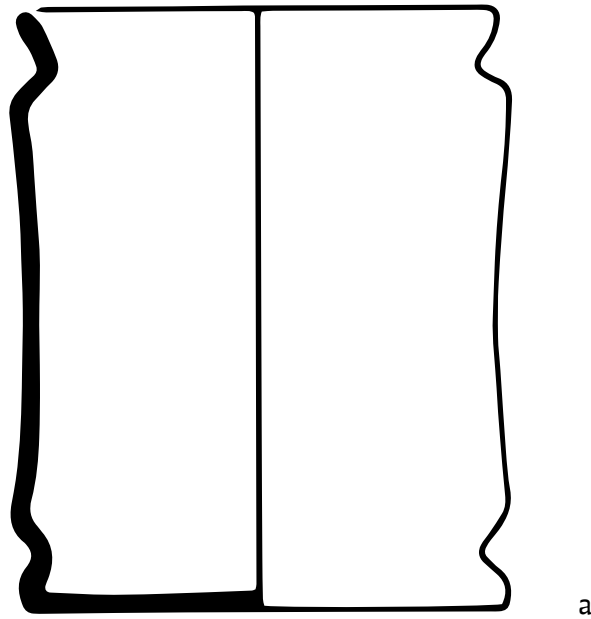

### 4.1.3 JAR

### Cylindrical Jar

**Defining characteristics:** A jar with roughly vertical body walls which in some cases may be slightly convex.

**Alternative names:** The terms Drug Jar and Ointment Jar should be confined to the specific variants of this form with a constriction at the neck, an everted rim and the base usually smaller than the maximum diameter. The term Ointment Jar is usually used for vessels with small capacity.

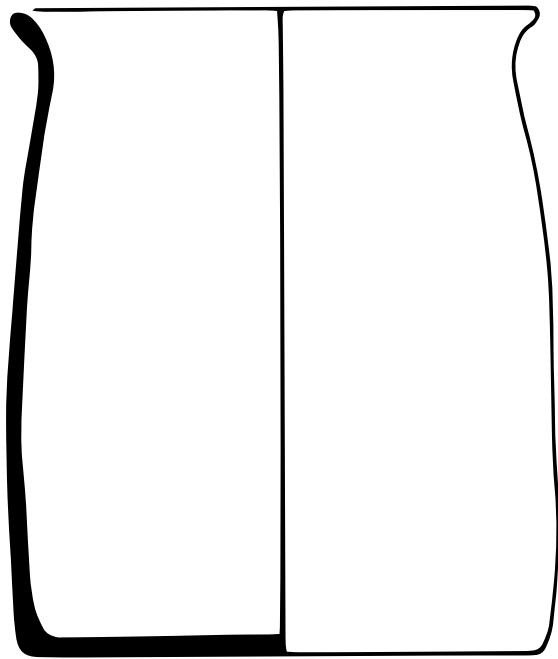

a

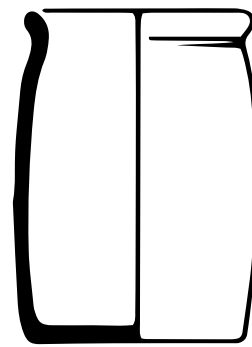

b

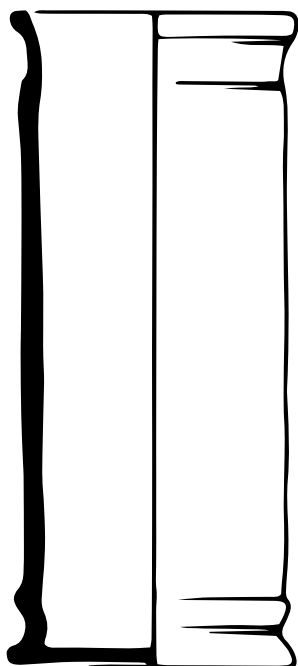

c

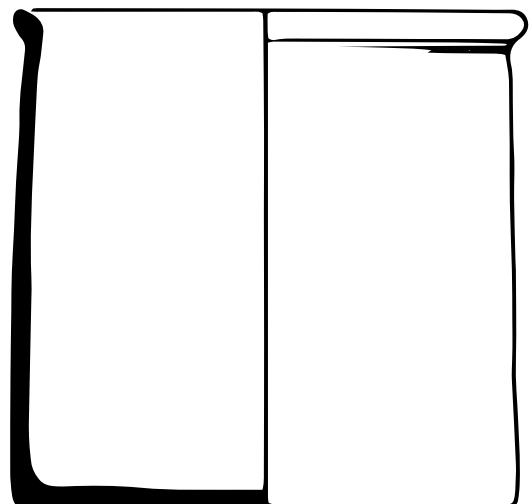

d

#### 4.1.4 JAR

#### Flared Jar

**Defining characteristics:** A jar with a profile that flares outwards from base to rim, but usually with a constriction at the neck.

Squat examples, with a height less than the minimum diameter, could be classified as BOWLS.

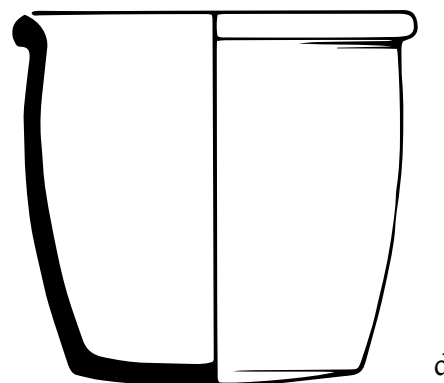
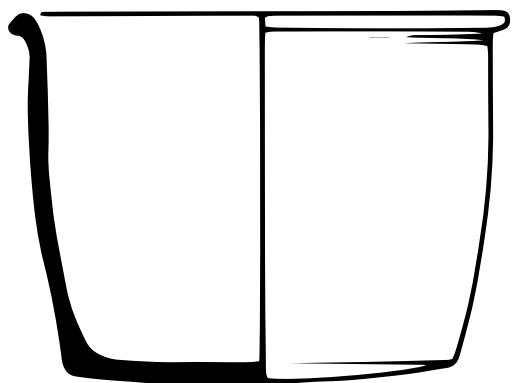
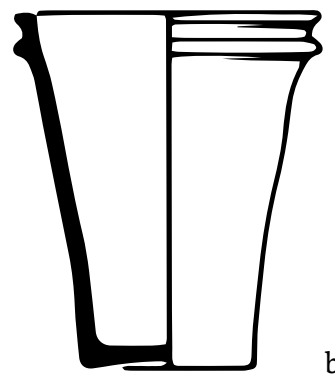
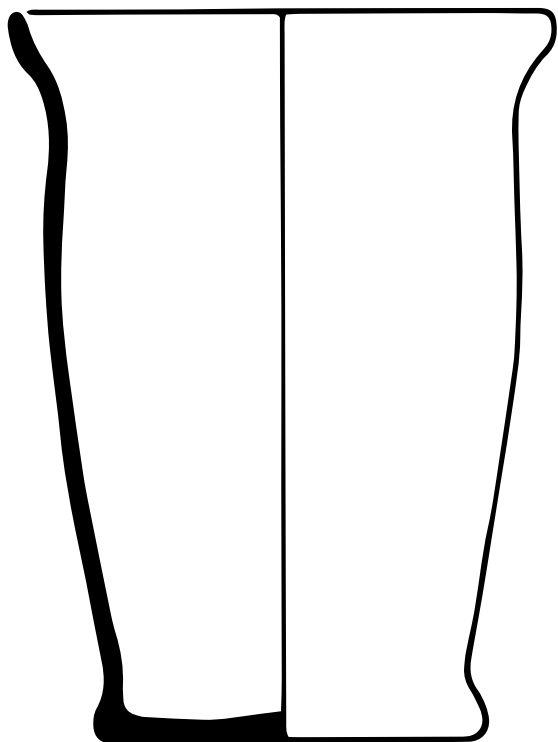



### 4.1.5 JAR

### Globular Jar

**Defining characteristics:** A jar with a rounded profile merging into a *rounded base* with no discernible basal angle.

**Alternative name:** A specific form of globular jar is the so-called 'Ginger Jar', a form with a rounded or very sagging base and an inturned, generally simple rim (d: see Hurst 1976, fig. 7.14, no.6).

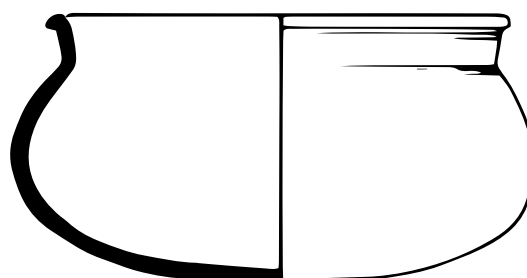
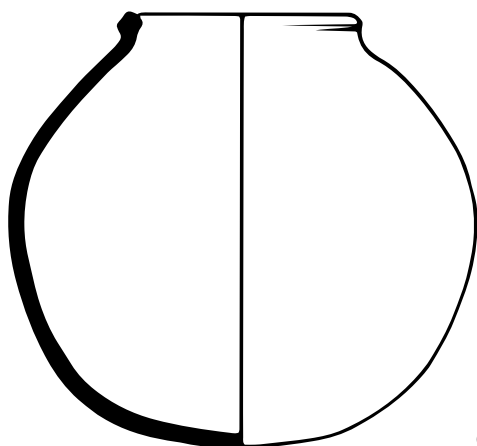
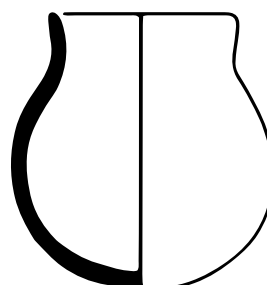
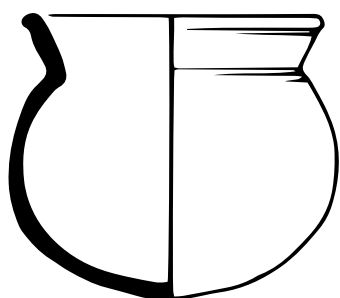
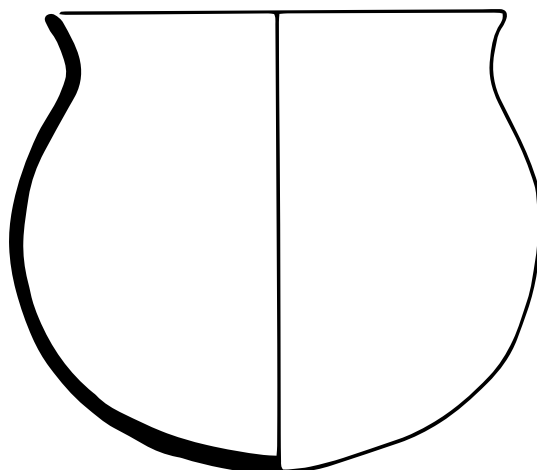

### 4.1.6 JAR

### Inturned Jar

**Defining characteristics:** A jar with a profile that slopes inwards from base to rim.

**Alternative names:** Particularly shallow examples (d) have been termed Peat Pots; this is a term with a restricted distribution in northern England (see also 'West Country' Dish: 5.3.1).

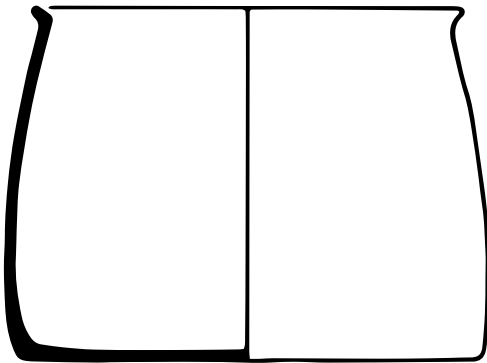

a

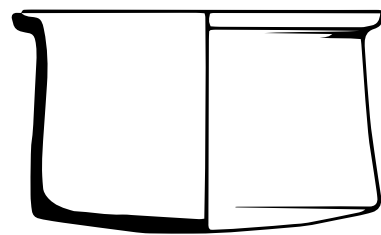

b

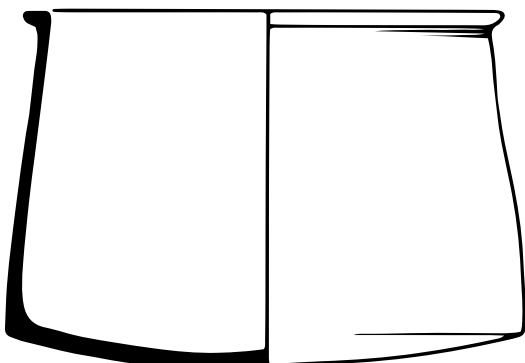

c

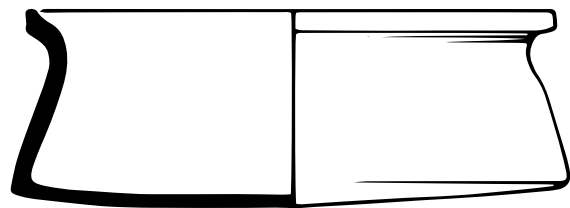

d

### 4.1.7 JAR

### Rounded Jar

**Defining characteristics:** A jar with an evenly rounded profile.

**Alternative name:** A specific type of small rounded jar is the MERCURY JAR (see 10.19).

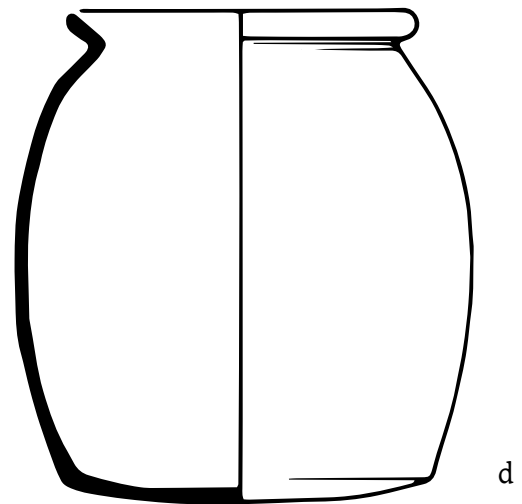
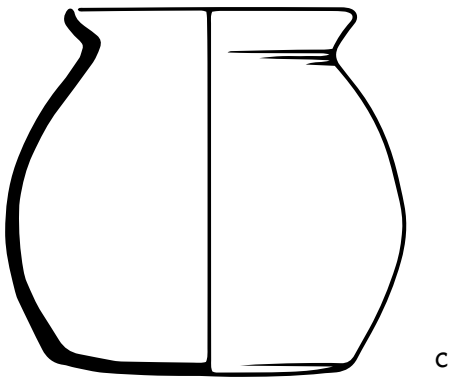
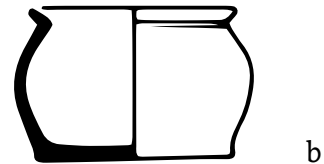
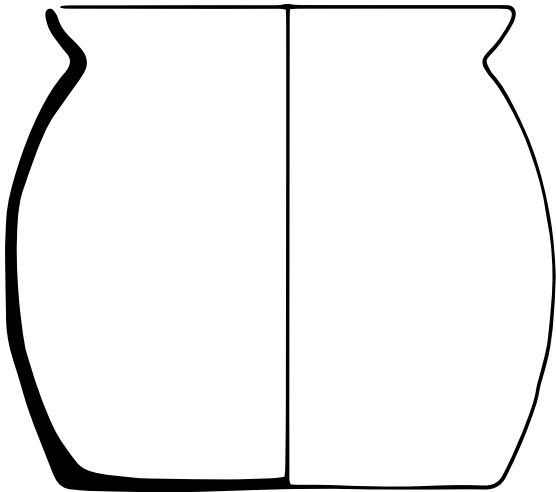

### 4.1.8 JAR

### Shouldered Jar

**Defining characteristics:** A jar with a roughly cylindrical or slightly flaring lower body and a rounded, inward sloping shoulder.

**Alternative name:** Tall shouldered jars have been termed Vases; this name, which has a specific functional connotation of display, should be used with great care.

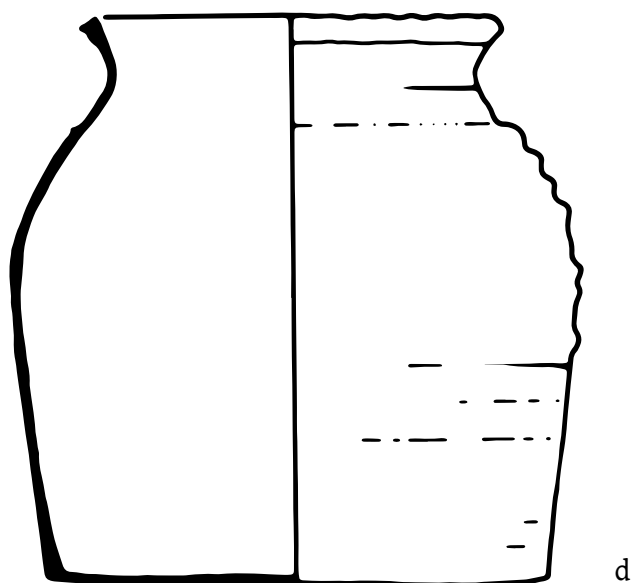
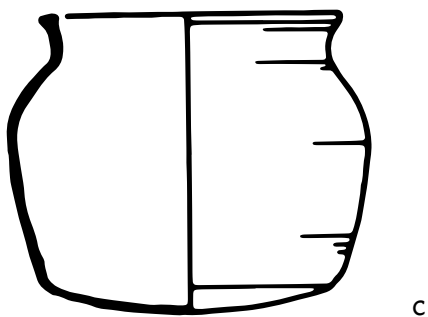
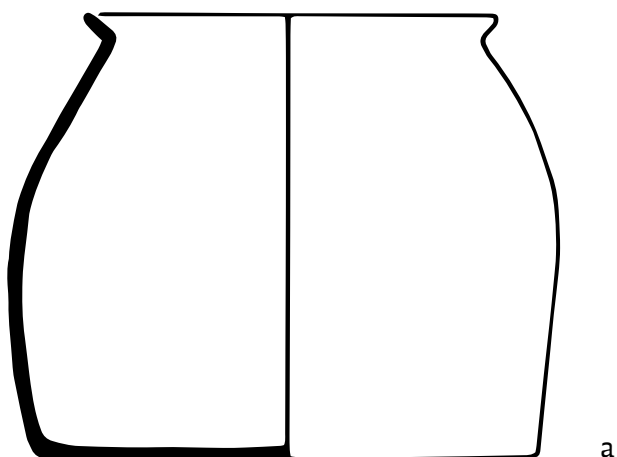

## 4.2 HANDLED JAR

**Defining characteristics:** A jar adapted by the addition of one or more *handles*. Profiles vary and should be classified in the same way as the basic JAR form (see 4.1.1-4.1.8).

Handled jars may be classified by the **number** of handles:

- 4.2.1      **Single-handled Jar**
- 4.2.3      **Double-handled Jar**
- 4.2.6      **Multi-handled Jar**

Some forms incorporate a specific **type** of handle:

- 4.2.2      **Basket-handled Jar**
- 4.2.4      **Bar Lug Jar**

Alternative names for handled jars generally reflect function:

- Bushel Pan (see 4.2.1)
- CAULDRON (see 4.4)
- Chamber Pot (see 4.2.1)
- Grape* (see 4.4)
- Ladle (see 4.3)
- PIPKIN (see 4.3)
- see also URINAL (see 10.28)
- and MILK CHURN (see 10.20)

## 4.2 HANDLED JAR

## Handled Jar Forms

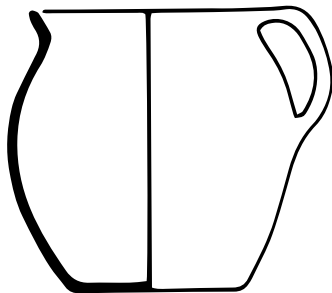

single-handled jar

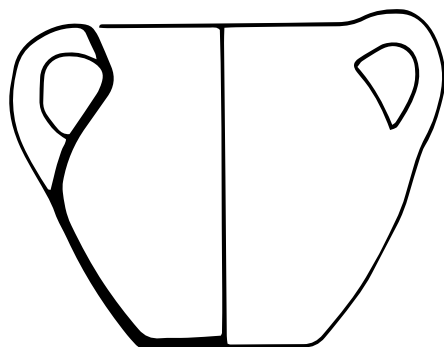

double-handled jar

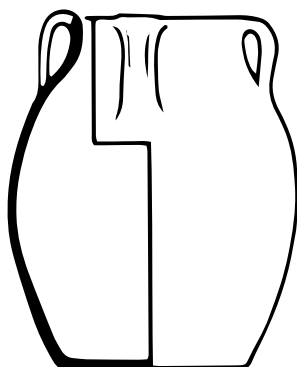

multi-handled jar

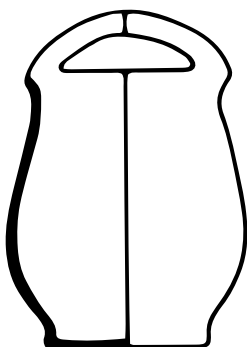

basket-handled jar

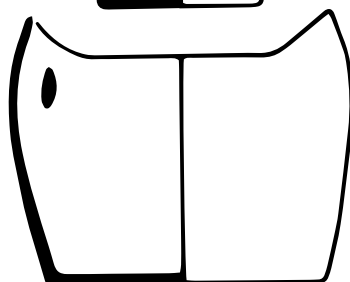

bar lug jar

### 4.2.1 HANDLED JAR

### Single-handled Jar

**Defining characteristics:** A jar adapted by the addition of a single *handle*. Profiles vary and should be classified in the same way as the basic JAR form (see 4.1.1-4.1.8).

**Alternative names:** Single-handled Jars, generally of rounded profile (see c) have often been called Chamber Pots, a specific functional term. Some Single-handled Jars have been called Bushel Pans or Measures, which are also functional definitions.

Jars with single *straight handles* are generally termed PIPKINS (see 4.3), with an implied cooking function.

Another specific form of single-handled jar is the URINAL (see 10.28).

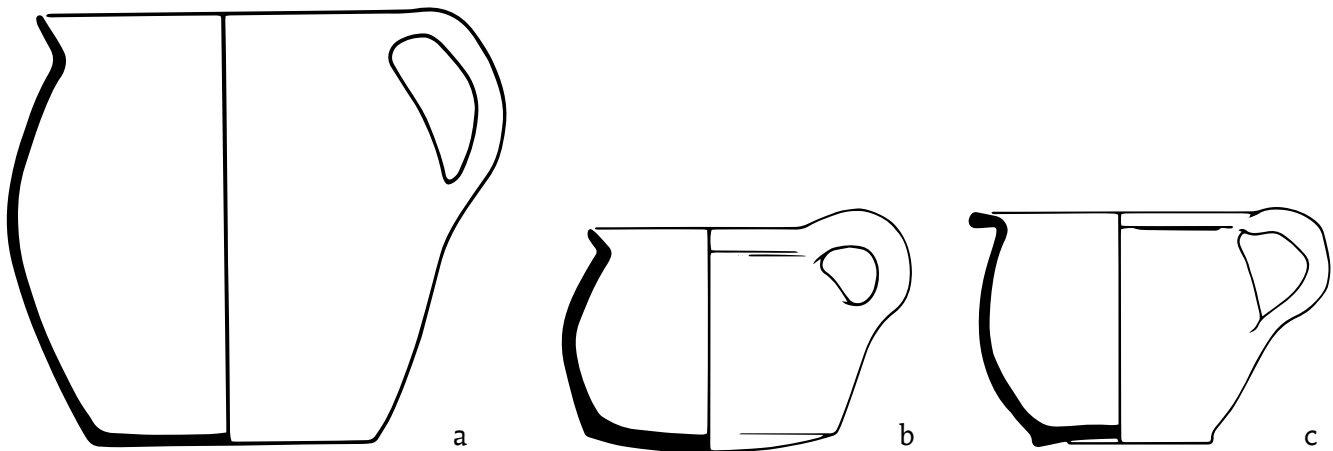

### 4.2.2 HANDLED JAR

### Basket-handled Jar

**Defining characteristics:** A jar with a single *handle* attached to the rim edge at both ends and looped over the top of the vessel. There may be a *lip*. Profiles can vary and should be classified in the same way as the basic JAR form (see 4.1.1-4.1.8).

**Alternative names:** A specific type of tall, basket-handled jar is a variant of the MILK CHURN (see 10.20).

Bucket-handled Jar is not recommended (see 11.4.1 for definition of *bucket handle*).

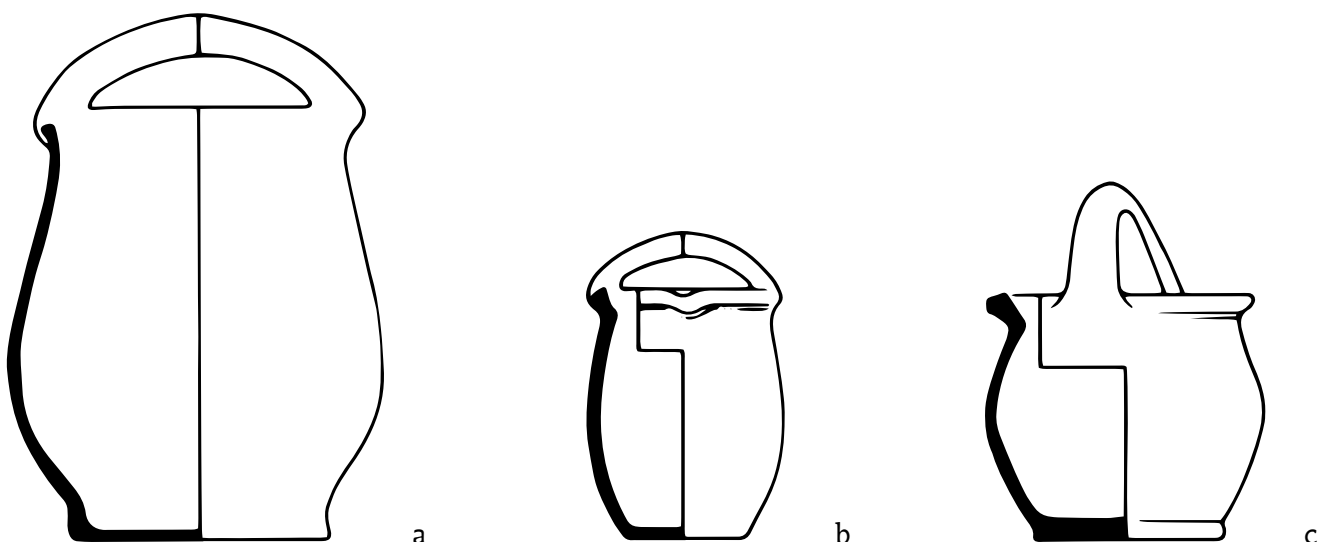

### 4.2.3 HANDLED JAR

### Double-handled Jar

**Defining characteristics:** A jar adapted by the addition of two *handles*. Profiles vary and should be classified in the same way as the basic JAR form (see 4.1.1-4.1.8). Handles may be horizontal or vertical *loops* or horizontal or curved *lugs*. The handles or lugs are nearly always opposed.

**Alternative names:** Two-handled Jar.

A specific type of tall, double-handled jar is a variant of the MILK CHURN (see 10.20).

A specific form with *lug handles* is the BAR LUG JAR (see 4.2.4).

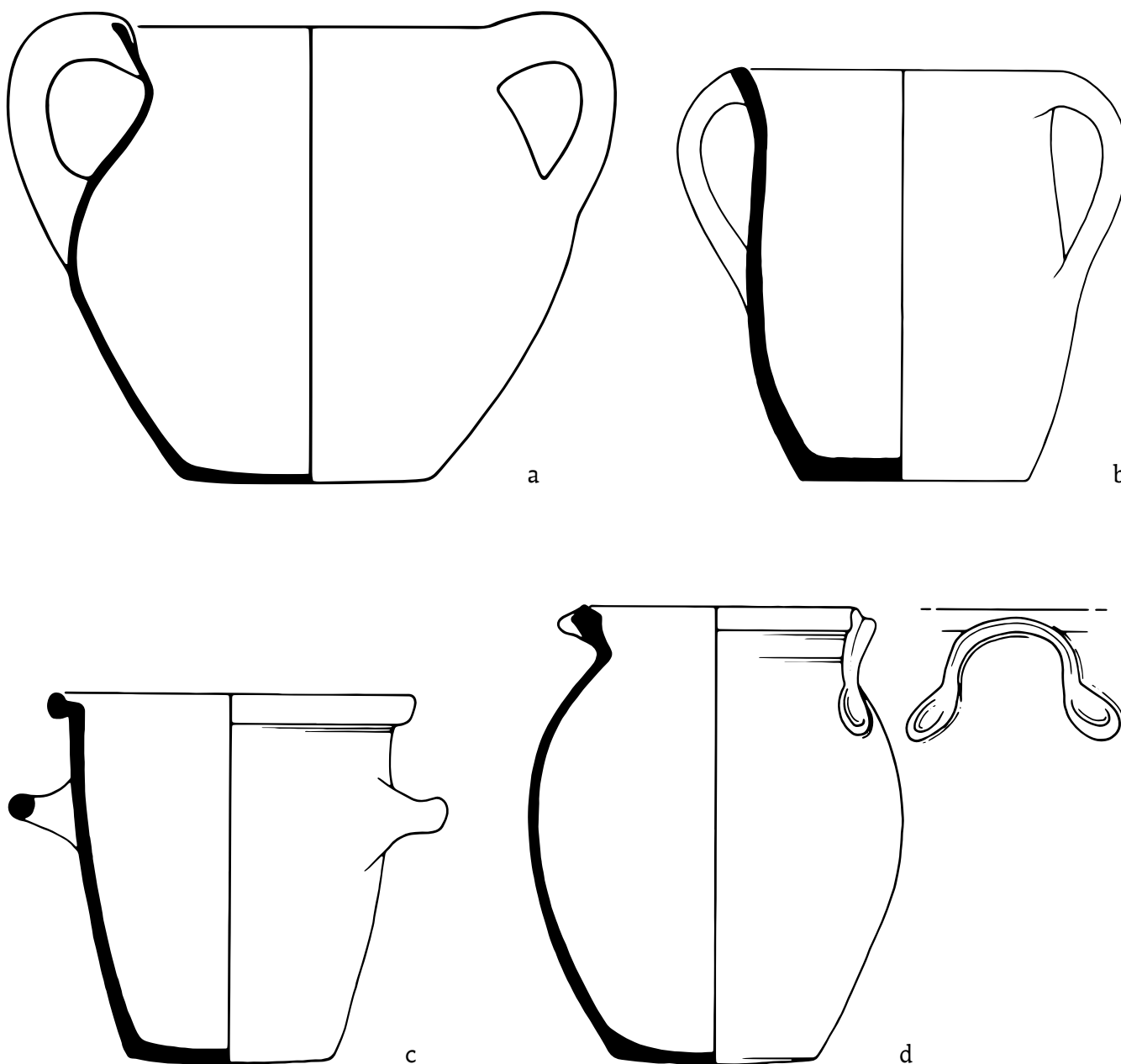



### 4.2.4 HANDLED JAR

### Bar Lug Jar

**Defining characteristics:** A distinctive form being a flat-based, straight-sided or slightly rounded jar, with two opposed, upright, rounded, tongue-shaped *lugs* raised from and above the rim (c.f. BAR LIP JAR, 4.2.5) and bridged by added, internal, horizontal bars or *struts* which were probably used to suspend the pot over the fire. The lugs would protect the suspending cord. The vessel is oval in plan at the rim and round at the base. This form is restricted to Cornwall.

**Bibliography:** Bruce-Mitford 1997, Hutchinson 1979.

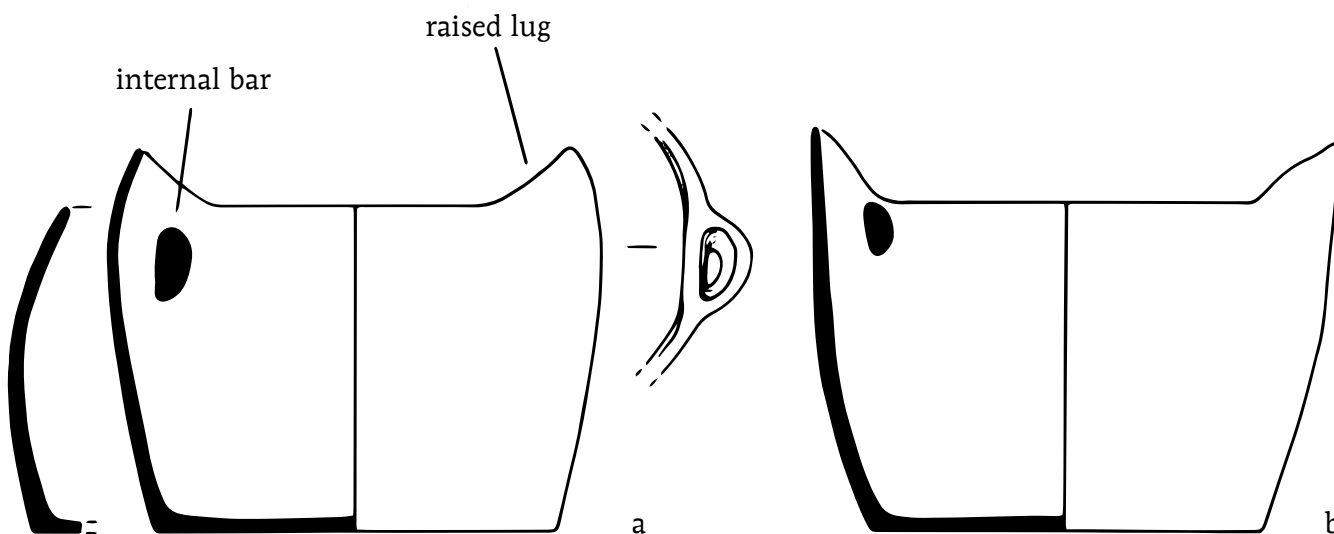

### 4.2.5 HANDLED JAR

### Bar Lip Jar

**Defining characteristics:** A jar with one or more *lips* added on the outside of the vessel wall over a hole pierced through the wall. Reconstructions usually show bases as globular, but the evidence is limited. The lips do not usually rise above rim level (c.f. BAR LUG JAR, 4.2.4).

**Bibliography:** Bruce-Mitford 1997.

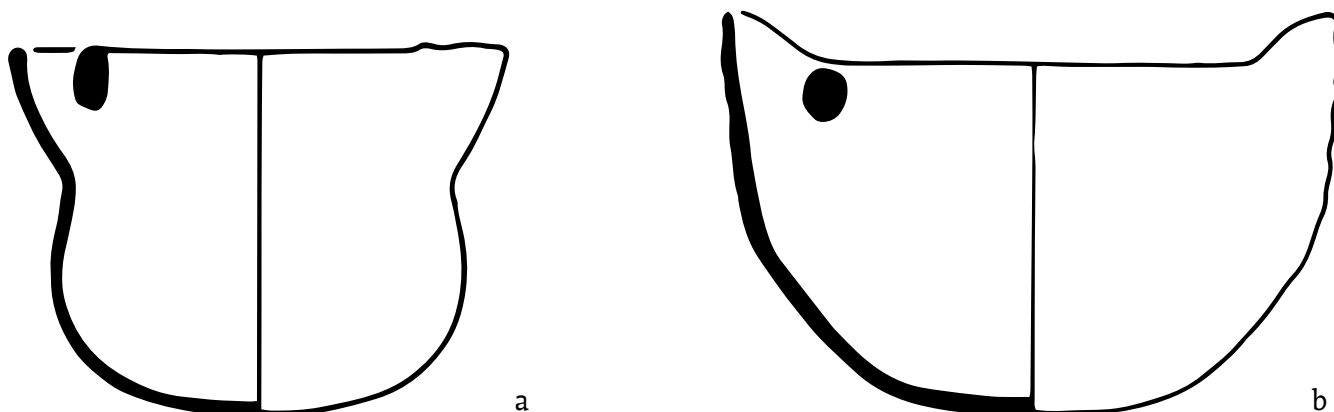

## 4.2.6 HANDLED JAR

### Multi-handled Jar

**Defining characteristics:** A jar adapted by the addition of three or more *vertical loop handles*. They may be equally spaced, or confined to one section of the circumference. Profiles vary and should be classified in the same way as the basic JAR form (see 4.1.1-4.1.8).

**Alternative names:** The number of handles may be designated, e.g. Three-handled Jar, Four-handled Jar.

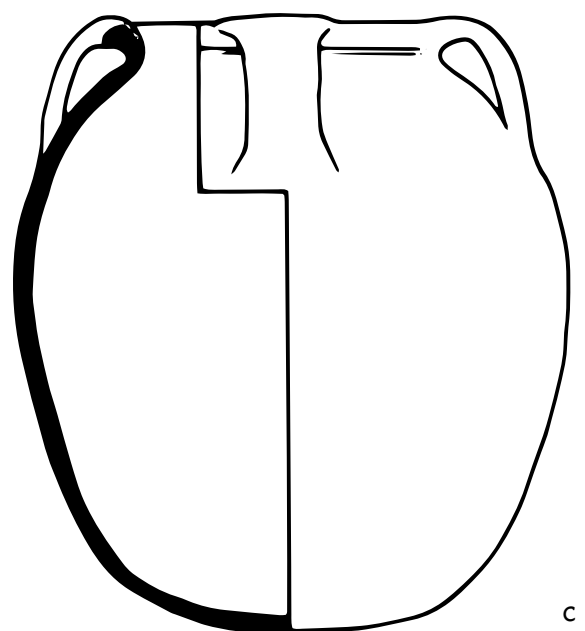
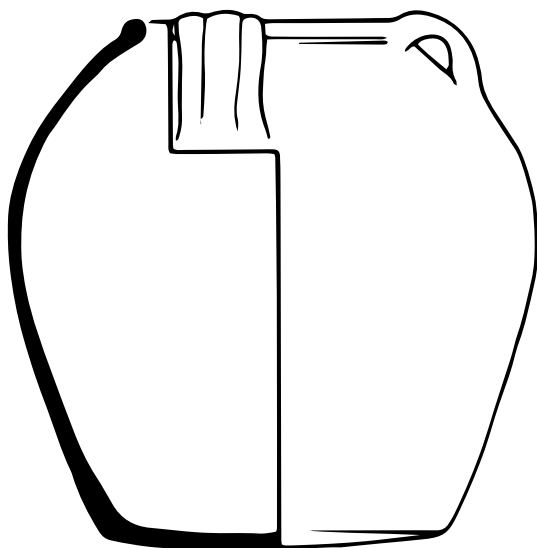
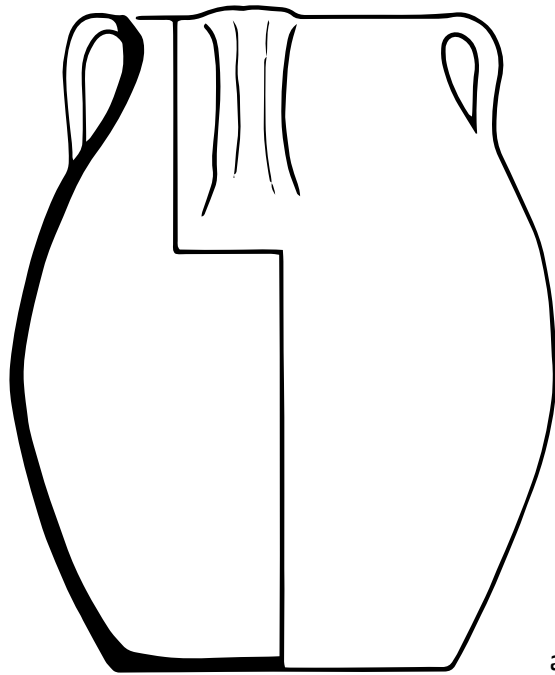

### 4.3 PIPKIN

**Defining characteristics:** A jar adapted by the addition of one *straight handle*, attached to either rim or body, and usually with a *lip* at right angles to the handle. The body is generally rounded, with a short neck and an everted rim, but profiles can vary and should be classified in the same way as the basic JAR form (see 4.1.1-4.1.8).

PIPKINS may be adapted by the addition of three *feet*:

#### 4.3.1 Tripod pipkin

**Alternative name:** Some small, globular pipkins with *hooked handles* (see e) are termed *Ladles*, a name usually applied to a specific type of Continental import (Paffrath ware: see Janssen 1983, 171).

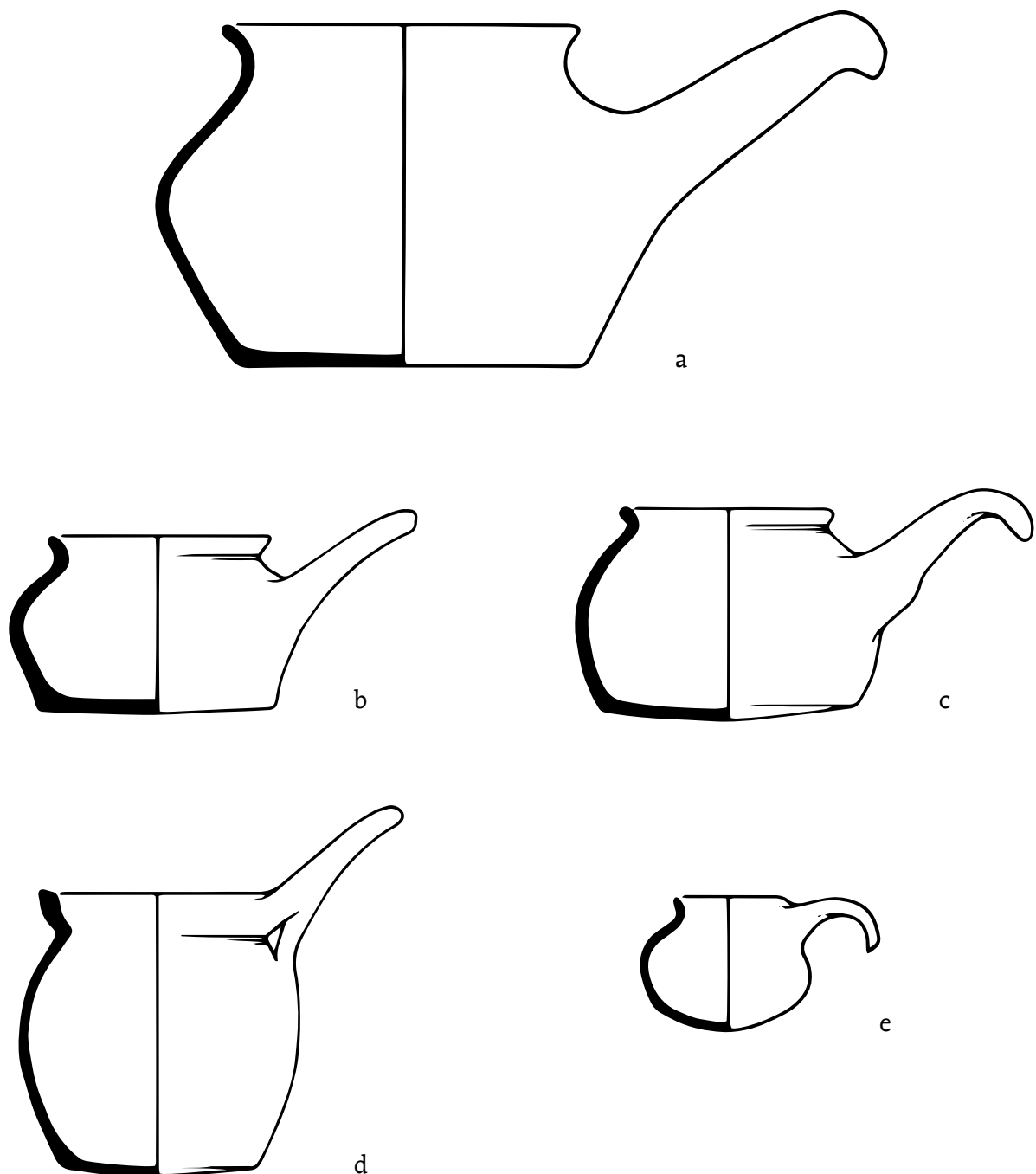

### 4.3.1 PIPKIN

### Tripod Pipkin

**Defining characteristics:** A jar adapted by the addition of a *straight handle* and three *feet*. Profiles vary and should be classified in the same way as the basic JAR form (see 4.1.1-4.1.8).

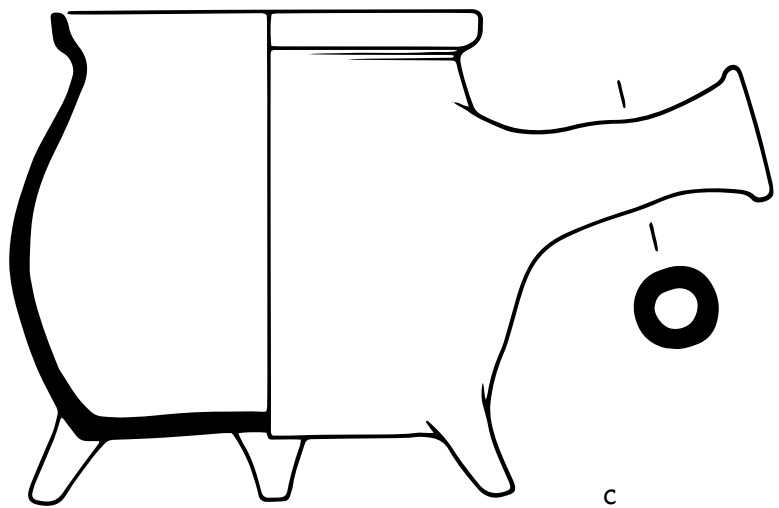
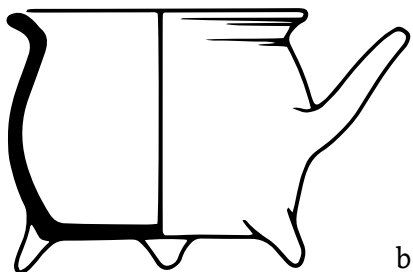
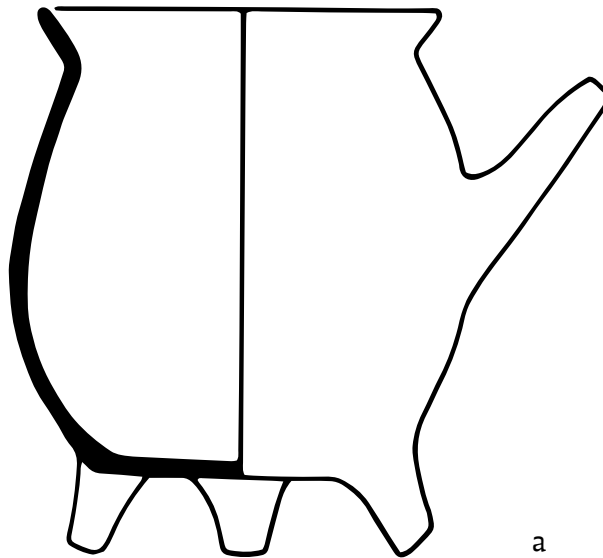

## 4.4 CAULDRON

**Defining characteristics:** A cauldron is a specific type of double-handled jar with three *feet*. The vessel has two opposed *vertical loop handles*, sometimes angled. Profiles vary and should be classified in the same way as the basic JAR form (see 4.1.1-4.1.8).

**Alternative names:** A *Grape* (pl. *Grapen*) is a specific form of cauldron, generally of rounded profile, made in the Low Countries.

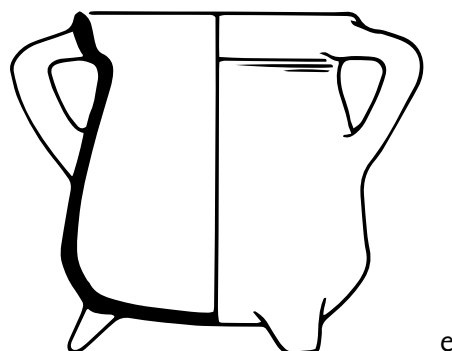
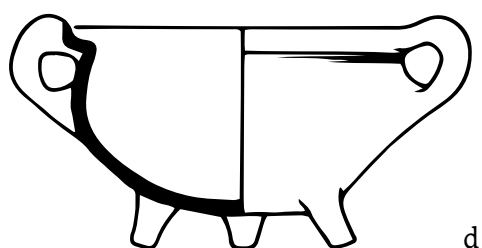
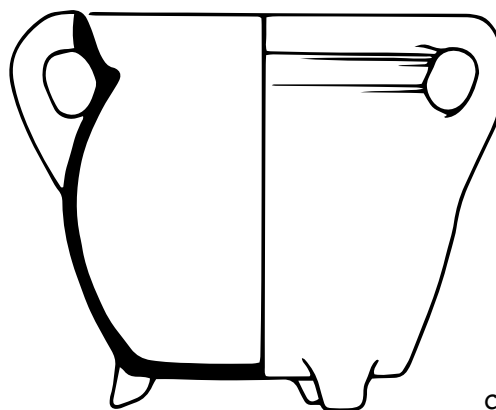
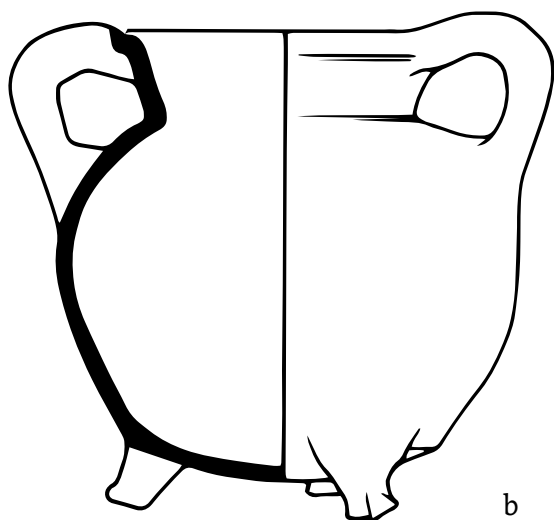
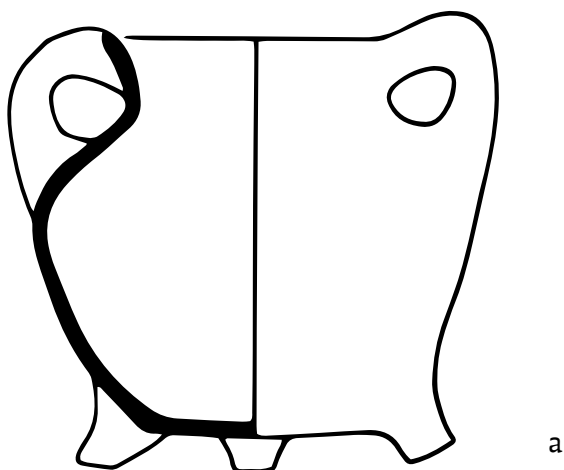

## 4.5 BUNGHOLE JAR

**Defining characteristics:** A jar adapted by the addition of a pierced *bunghole* just above the base. The bunghole can be simply a hole in the vessel wall or made through a circular knob or disc of clay. In use the bunghole would probably have held a spigot or tap for drawing liquid from the vessel. There may be one or two *vertical loop handles*. Profiles vary and should be classified in the same way as the basic JAR form (see 4.1.1-4.1.8).

**Alternative names:** Cistern.

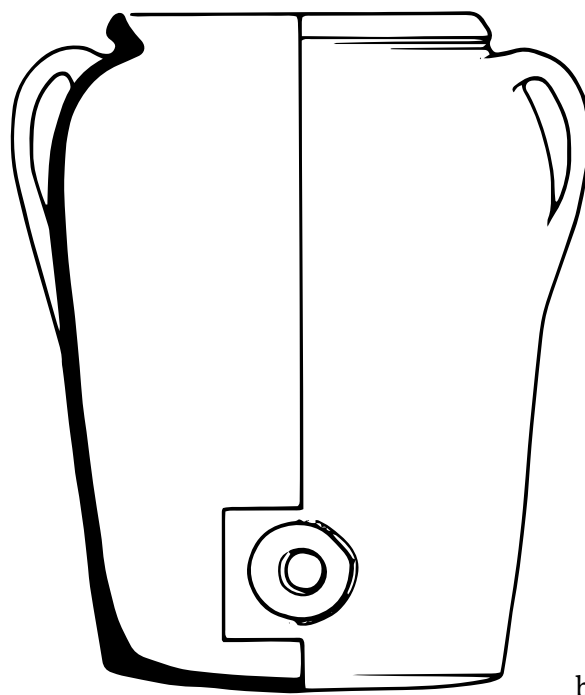
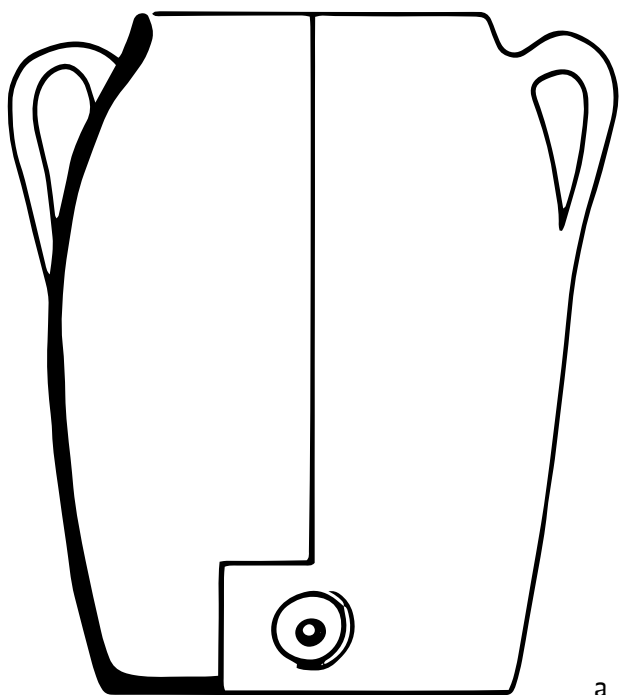

## SECTION 5: BOWLS AND DISHES

---

### Contents

#### Introduction to BOWLS and DISHES

#### 5.1 BOWL

- 5.1.1 Biconical Bowl
- 5.1.2 Carinated Bowl
- 5.1.3 Concave-sided Bowl
- 5.1.4 Flared Bowl
- 5.1.5 Hemispherical Bowl
- 5.1.6 Rounded Bowl
- 5.1.7 Straight-sided Bowl
- 5.1.8 Spouted Bowl
- 5.1.9 Pedestal Bowl
- 5.1.10 Lobed Bowl
- 5.1.11 Divided Bowl
- 5.1.12 Multiple Bowl
- 5.1.13 Colander

#### 5.2 HANDLED BOWL

- 5.2.1 Single-handled Bowl
- 5.2.2 Socketed Bowl
- 5.2.3 Basket-handled Bowl
- 5.2.4 Double-handled Bowl
- 5.2.5 Multi-handled Bowl

#### 5.3 DISH

- 5.3.1 Inturned Dish
- 5.3.2 Pedestal Dish
- 5.3.3 Lobed Dish
- 5.3.4 Divided Dish
- 5.3.5 Multiple Dish
- 5.3.6 Dripping Dish

#### 5.4 PLATE

#### 5.5 FRYING PAN

- 5.5.1 Skillet

## Introduction to BOWLS and DISHES

This section includes all major vessel forms defined as ‘open’ on the basis of a rim diameter equal to, or greater than, the base diameter, although there are a few specific exceptions to this criterion. The major vessel classes considered here are BOWLS and DISHES, which encompass other broad terms such as Pans, PLATES and Trays.

The terms BOWL and DISH are rarely defined closely and are frequently used interchangeably, particularly when the depth of these open vessels is unknown. More specific definitions are proposed here, together with a basic system for classification.

### 5.1 BOWL

**Defining characteristics:** The term BOWL is not always closely defined, and is frequently used interchangeably with the term DISH, as a general term for an open vessel. However, a more restricted definition is proposed here, based upon terminology used for Romano-British pottery (Webster 1976, 171-8; Orton 1980, 34) and adopted for, amongst others, Surrey/Hampshire Border wares (Pearce 1992). This defines a BOWL as an open form, with a rim diameter greater than the base diameter and a height of one-third or more of its rim diameter. Within these parameters, BOWLS cover a wide variety of shapes and sizes. Some suggestions for means of classification are made here.

There may be some overlap with squat JAR forms, particularly those without a pronounced rim constriction (see 4.1.4 Flared Jar), and this overlap is especially apparent in the definition of Bowl forms in the Early Saxon period (see 5.1.1 Biconical Bowl; 5.1.5 Hemispherical Bowl).

**Bases** are shown flat in the stylised drawings, except for forms where a rounded base is an integral part of the profile, e.g. Hemispherical Bowl (5.1.5).

### 5.1 BOWL

### Bowl Profiles

BOWLS are classified by **profile** (see below):

- 5.1.1 Biconical Bowl
- 5.1.2 Carinated Bowl
- 5.1.3 Concave-sided Bowl
- 5.1.4 Flared Bowl
- 5.1.5 Hemispherical Bowl
- 5.1.6 Rounded Bowl
- 5.1.7 Straight-sided Bowl

and can be further subdivided by *size* or *capacity* (but see Section 1.3.2). Some functional terms for the basic BOWL shape are dependent primarily on size: small bowls may be termed Drinking Bowls or CUPS; large examples may be termed Pans or Pancheons.



## 5.1 BOWL

## Bowl Profiles

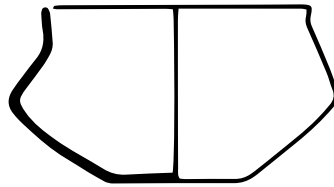

biconical

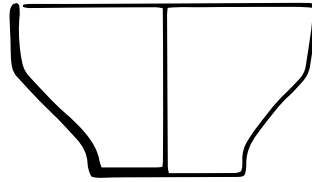

carinated

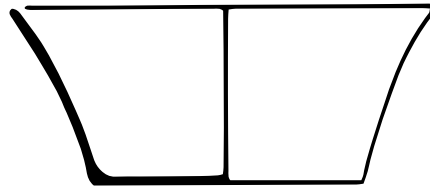

concave-sided

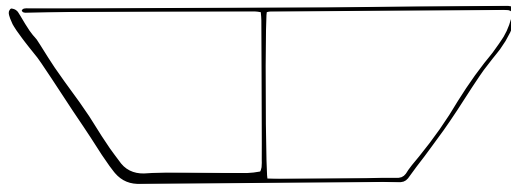

flared

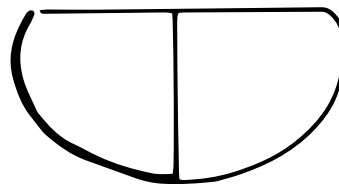

hemispherical

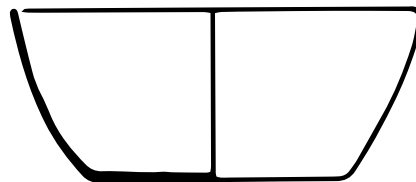

rounded

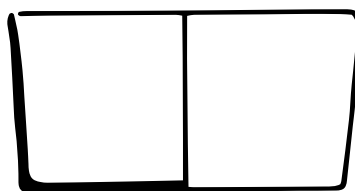

straight-sided

## 5.1 BOWL

### Bowl Depths

BOWLS can also be classified by **depth** (see below):

SHALLOW: maximum diameter between one-third and two-thirds of height

MEDIUM: maximum diameter between two-thirds of height and equivalent of height

DEEP: maximum diameter equal to height

**Shallow** bowls may fall into the category of DISHES (see 5.3). **Deep** bowls may overlap with JARS (see 4.1).

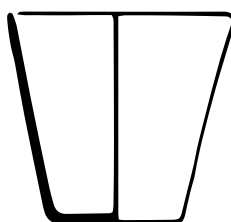

deep

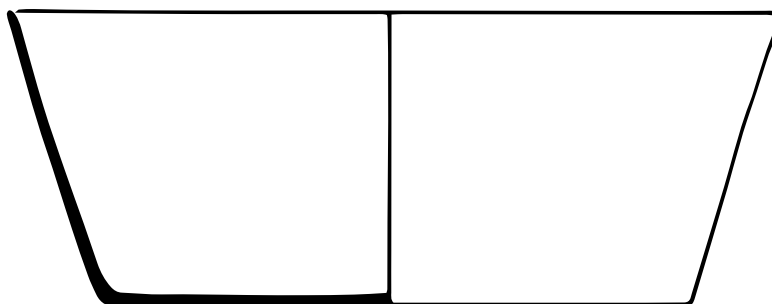

medium

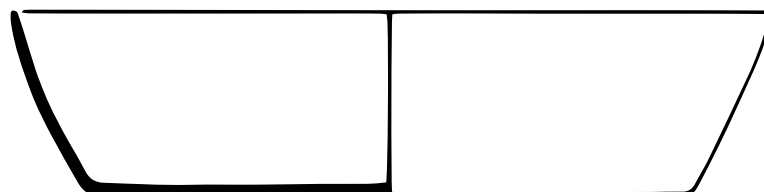

shallow

## 5.1 BOWL

BOWLS may be adapted by the addition of *component parts*, such as one or more *handles, feet, pedestal bases* and/or *spouts*:

- 5.2       Handled Bowl
- 5.1.8     Spouted Bowl
- 5.1.9     Pedestal Bowl
- 5.5       Frying Pan
- 5.5.1     Skillet

or by *piercing*:

- 5.1.13    Colander
- see also CHEESE PRESS (10.5)

or by *division or multiplication*:

- 5.1.11    Divided Bowl
- 5.1.12    Multiple Bowl

Bowls may be described by their **shape in plan**, e.g. oval, rectangular (see also Lobed Bowl: 5.1.10).

Bowls may be a specialised form copying vessels in other materials:  
see MORTAR (10.22)

BOWLS may also be the basic element of more complex open forms:

- CHAFING DISH (see 8.6)
- LAMP (see 8.2)
- DOUBLE DISH (see 10.9)
- FLOWER POT (see 10.14)

BOWLS may be inverted and further adapted to form CURFEWS (see 8.5) or LIDS (see Section 7).

Names which have been attributed to the basic BOWL shape which often reflect function include:

specific shapes:

- Cream Pan (see 5.1.4)
- Pan (see 5.1.3, 5.1.4)
- Pancheon (see 5.1.3, 5.1.4)
- Settling Pan (see 5.1.4)
- Stool Pan (see 5.1.4)

non-specific shapes:

- Basin

Some of these are dependent primarily on *size* (see above), others on specific forms (**profiles**), or on a combination of the two; terminology may be regionally based.

### 5.1.1 BOWL

### Biconical Bowl

**Defining characteristics:** A bowl whose form resembles two cones joined together at their widest points, forming a carination.

While this form, by nature of the rim diameter being smaller than the girth, technically falls within the range of JARS, the term BICONICAL BOWL is frequently used for wide-mouthed, squat examples of the Early Saxon period (e.g. a, b).

**Alternative name:** The Early Saxon examples have been termed *Schalenuernen* (sing. *Schalenuerne*).

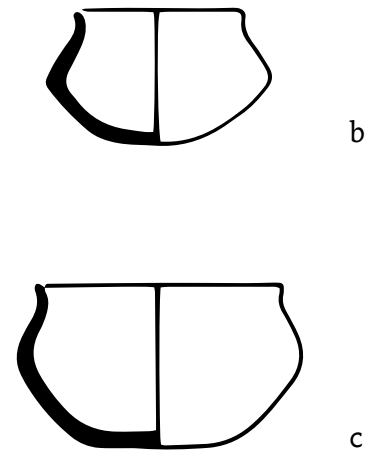
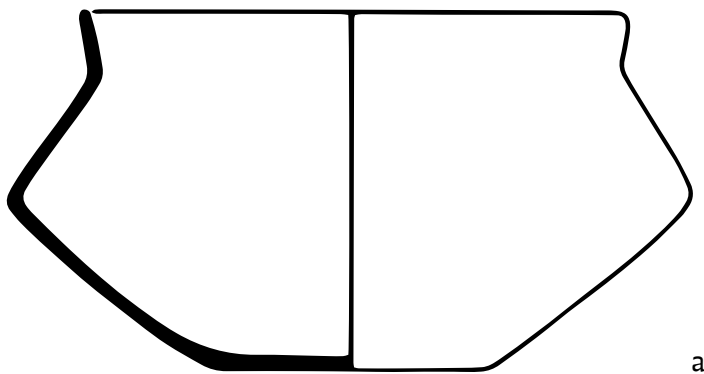

### 5.1.2 BOWL

### Carinated Bowl

**Defining characteristics:** A bowl with a sharp change of angle in the vessel wall, generally at the point of maximum diameter. The carination may be in the upper or lower half of the vessel.

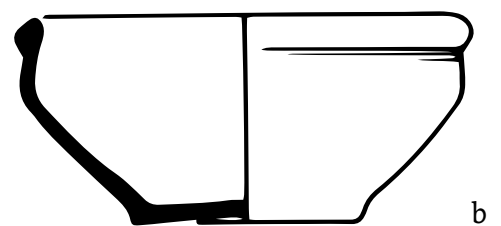
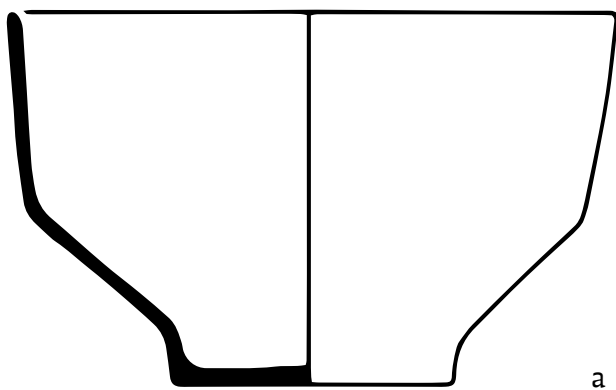

### 5.1.3 BOWL

### Concave-sided Bowl

**Defining characteristics:** A bowl with concave body walls.

**Alternative name:** Wide-mouthed, narrow-based examples, particularly those in larger sizes, have been termed Pans or Pancheons (see also 5.1.4 FLARED BOWL).

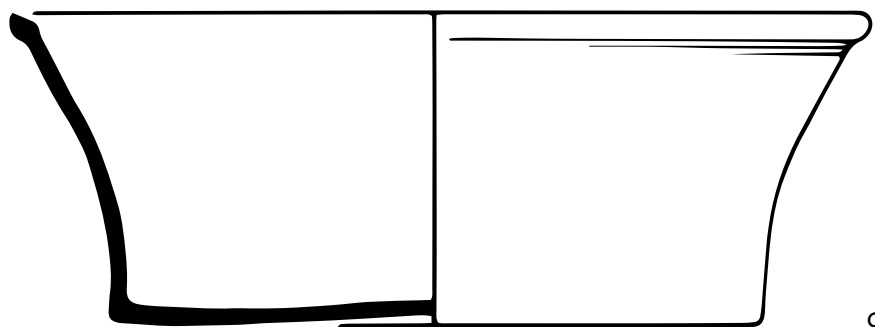
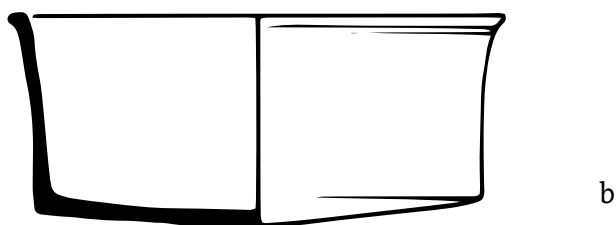
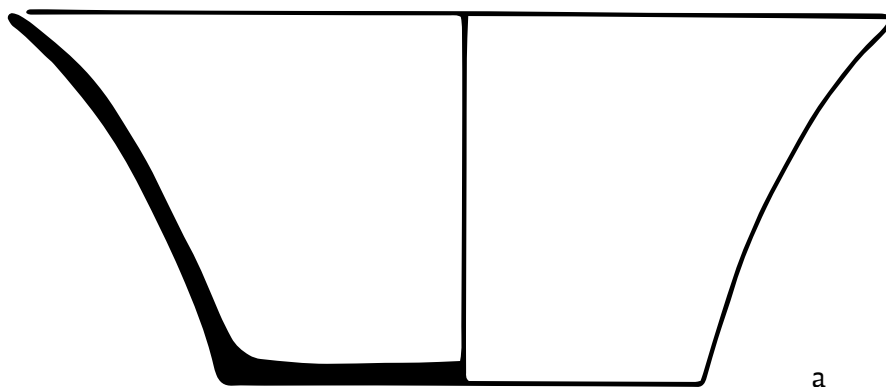

### 5.1.4 BOWL

#### Flared Bowl

**Defining characteristics:** A bowl with straight sides which turn outwards, forming an obtuse angle with the base, i.e. an inverted, truncated, conical shape.

**Alternative names:** Wide-mouthed, narrow-based flared bowls (e.g. c, below), particularly those in larger sizes, have often been termed Pans or Pancheons (see also 5.1.3 CONCAVE-SIDED BOWL); these vessels may be associated with dairying activities, reflected in the more specific alternative names of Cream Pan or Settling Pan.

Flared bowls of medium depth to deep, with wide, horizontal *everted rims* (see b, below), may be called Stool Pans, indicating possible function. These vessels may also be single-handled (see 5.2.1).

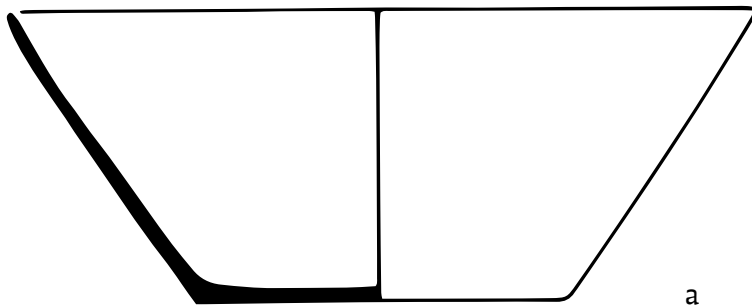

a



b

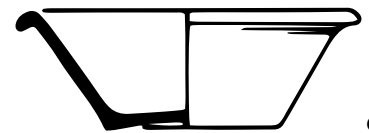

c

### 5.1.5 BOWL

#### Hemispherical Bowl

**Defining characteristics:** A bowl with no noticeable base angle, so that the walls and base form a continuous rounded curve.

The term is also used for squat, wide-mouthed examples of the early Saxon period, although these may have a slight rim constriction (b).

**Alternative name:** Small examples may be called BEAKERS (see also 6.1).

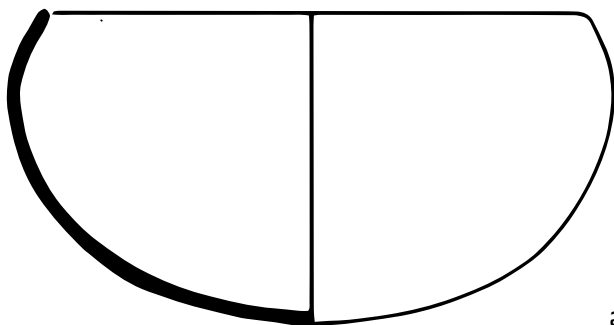

a

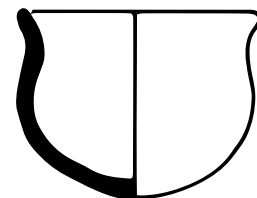

b

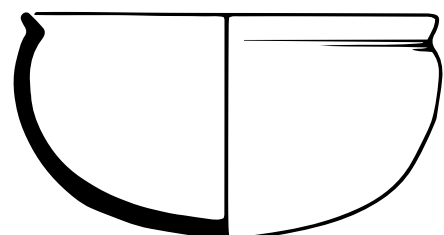

c

### 5.1.6 BOWL

### Rounded Bowl

**Defining characteristics:** A bowl with convex body walls.

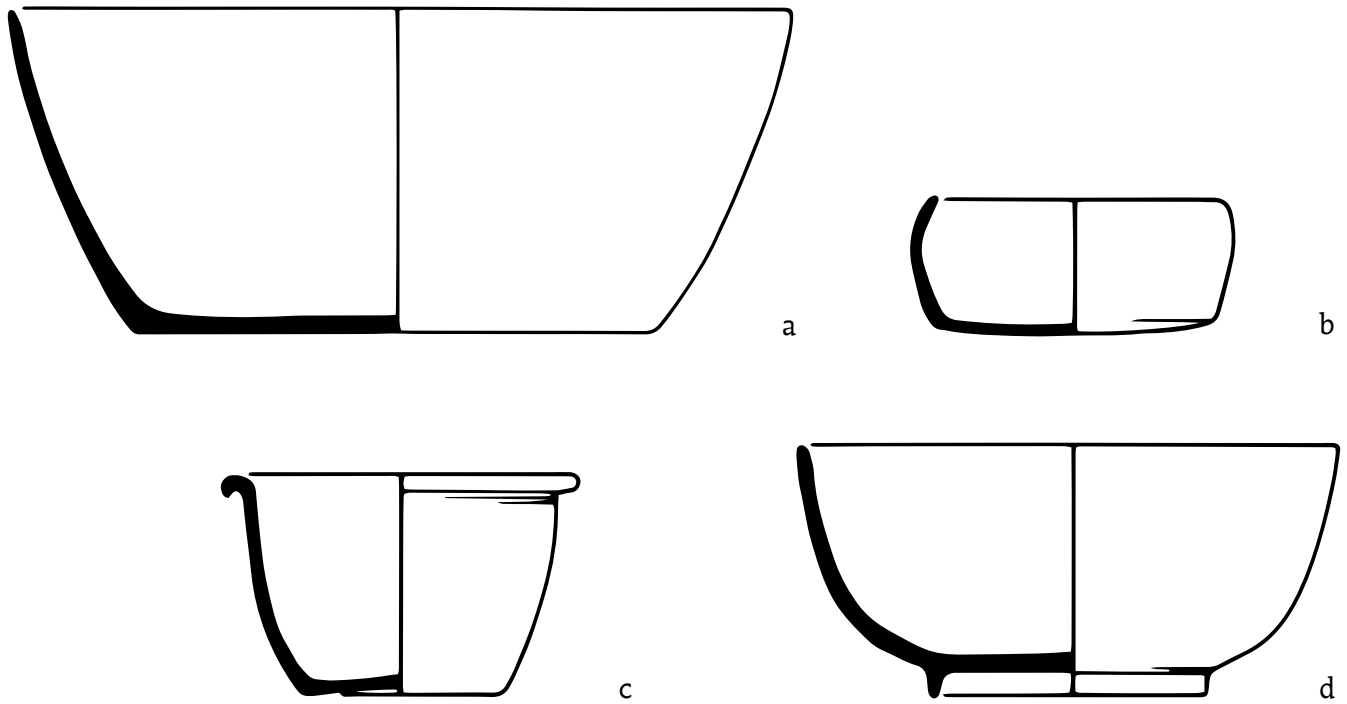

### 5.1.7 BOWL

### Straight-sided Bowl

**Defining characteristics:** A bowl with straight sides which are at an approximate right angle to the base, i.e. a roughly cylindrical shape.

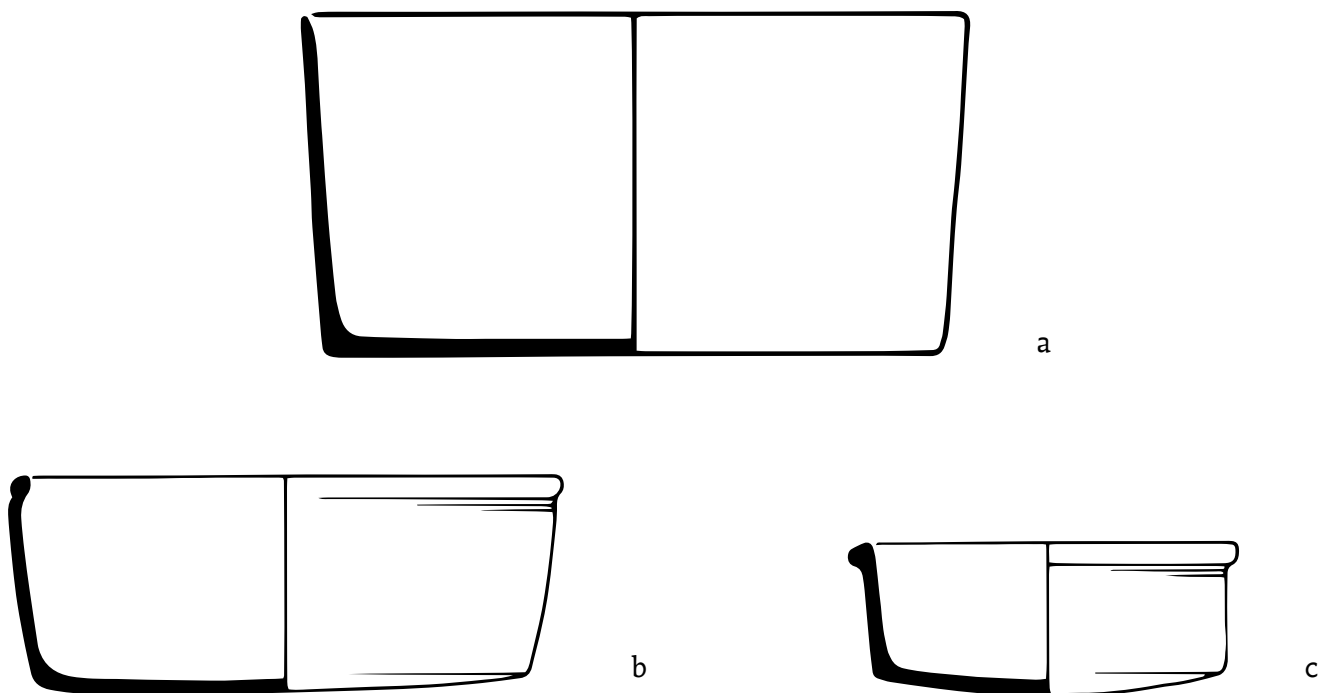

## 5.1.8 BOWL

## Spouted Bowl

**Defining characteristics:** A bowl adapted by the addition of a short *tubular spout* applied just below the rim. Profiles vary and should be classified in the same way as BOWLS (see 5.1.1-5.1.7).

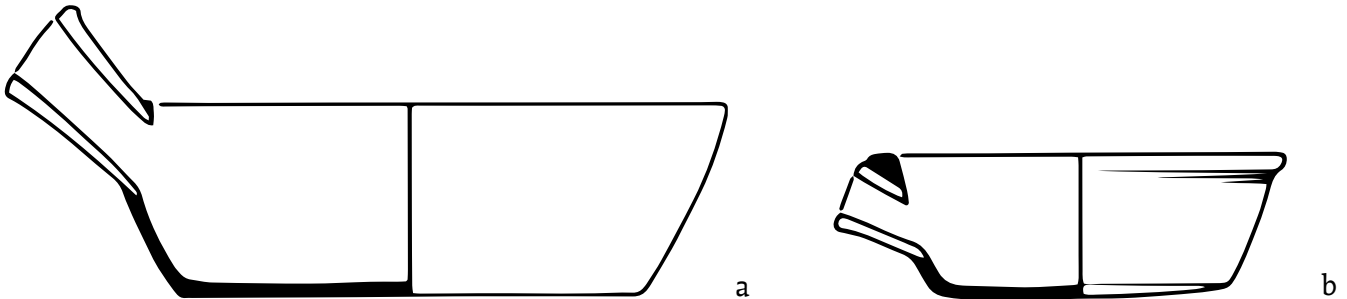

## 5.1.9 BOWL

## Pedestal Bowl

**Defining characteristics:** A bowl adapted by having a *pedestal base*. Profiles vary and should be classified in the same way as BOWLS (see 5.1.1-5.1.7).

**Alternative name:** On the Continent, these vessels, particularly ornate examples, may be called *Tazze* (sing. *Tazza*) (see b, below; see also 5.3.2 PEDESTAL DISH).

Early Saxon examples (e.g. c, below) may be termed *Standfussschalen* (sing. *Standfussschale*).

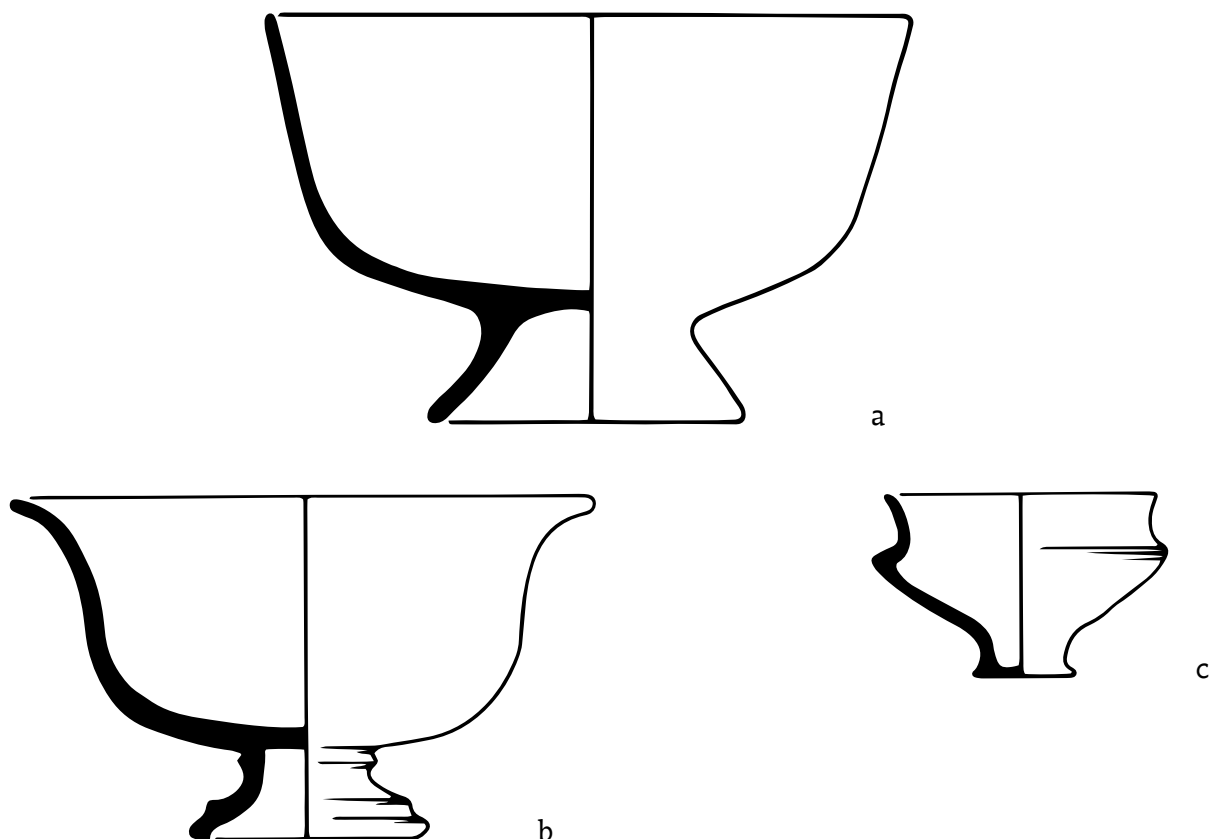



## 5.1.10 BOWL

## Lobed Bowl

**Defining characteristics:** A bowl comprising three or more equally spaced *lobes*. There may be one or more moulded animals or other figures inside the base (see 12.1: Zoomorphic applied decoration). There may be two or more *handles*. Profiles vary and should be classified in the same way as BOWLS (see 5.1.1-5.1.7).

The distinction between LOBED BOWLS and LOBED CUPS (see 6.2.6) may not always be apparent, but Lobed Bowls generally have a *flat base*, whereas Lobed Cups usually have a narrow waisted or *pedestal base*.

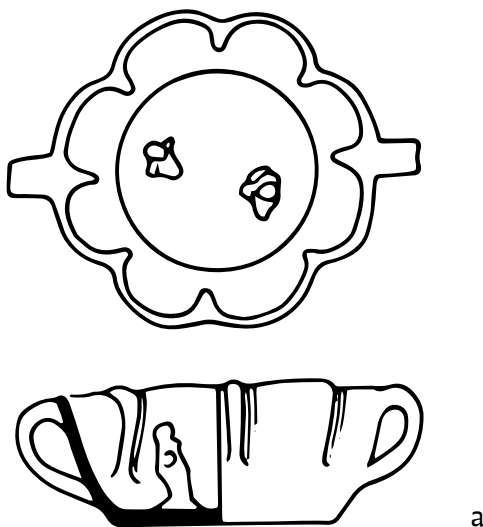

a

## 5.1.11 BOWL

## Divided Bowl

**Defining characteristics:** A bowl divided into two or more units (compartments) by vertical slab *partitions*. Profiles vary and should be classified in the same way as BOWLS (see 5.1.1-5.1.7; see also 5.1.12 MULTIPLE BOWL).

**Alternative name:** Condiment Bowl has been used.

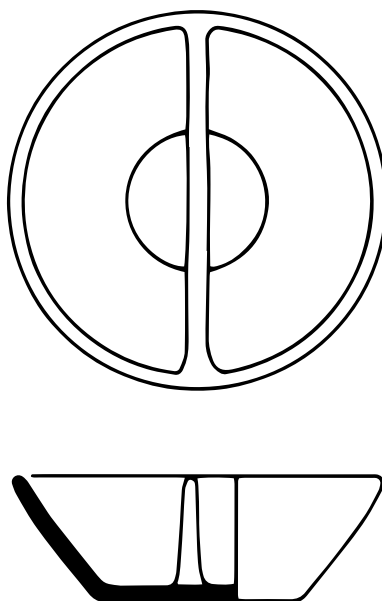

a

## 5.1.12 BOWL

## Multiple Bowl

**Defining characteristics:** A vessel comprising two or more bowls, generally of small size, joined together. The profiles of the individual bowls vary, and should be classified in the same way as BOWLS (see 5.1.1-5.1.7; see also 5.1.11 DIVIDED BOWL). There may be one or more *handle(s)* of varying forms.

**Alternative name:** Condiment Bowl has been used.

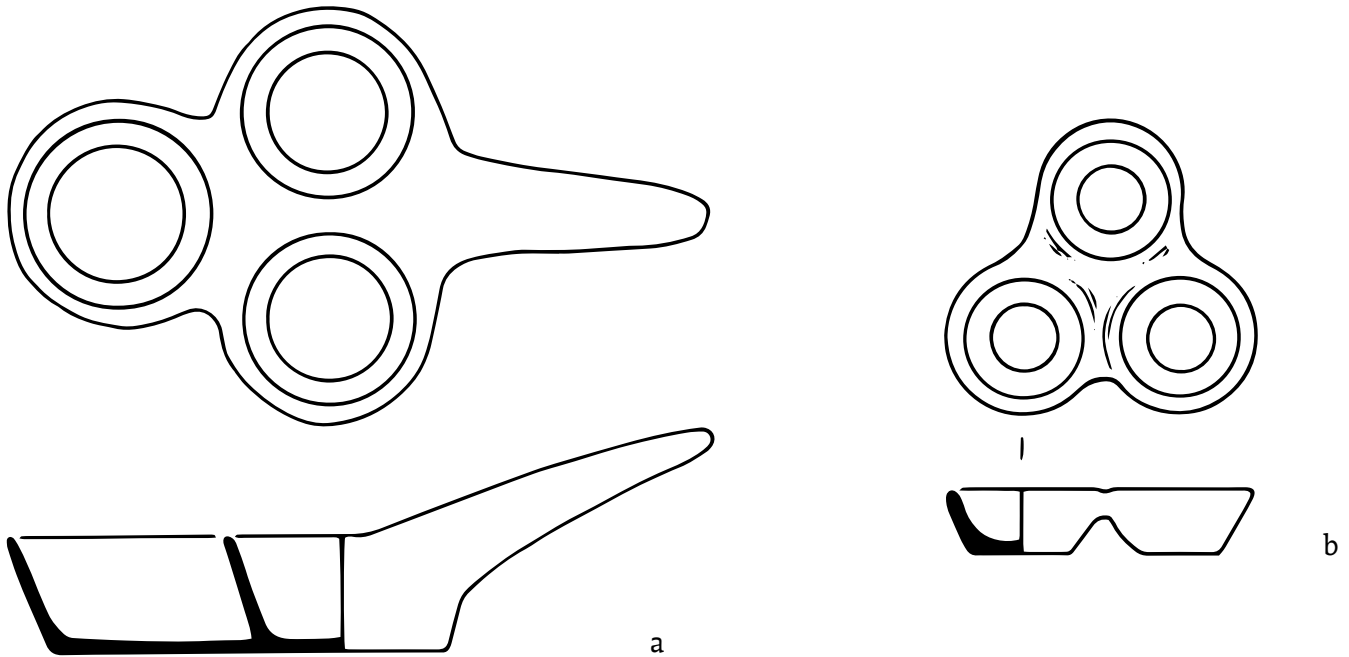

## 5.1.13 BOWL

## Colander

**Defining characteristics:** A bowl adapted for straining by multiple piercing of the vessel wall and base. Profiles vary and should be classified in the same way as BOWLS (see 5.1.1-5.1.7). Some examples have three *feet*, and one or two opposed *handles*.

**Alternative name:** Strainer has been used.

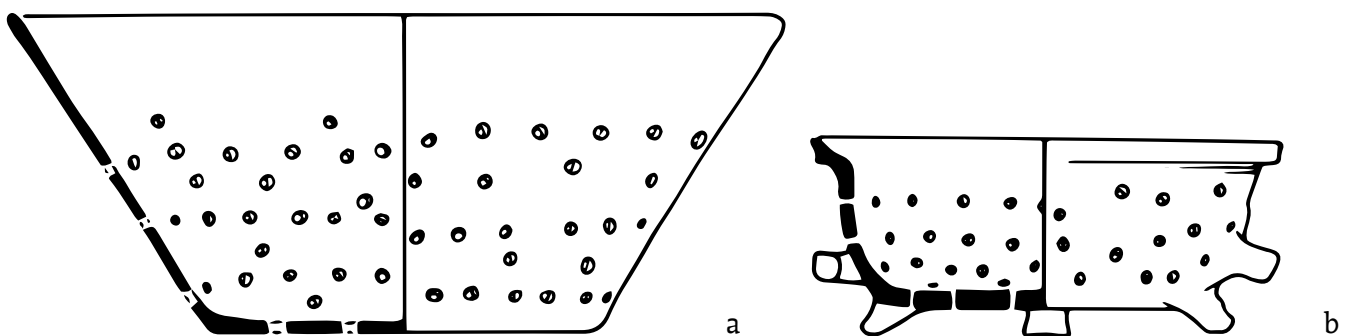

## 5.2 HANDLED BOWL

**Defining characteristics:** A bowl adapted by the addition of one or more *handles*. The handles may be vertical or horizontal *loops*, or *straight*, or may comprise vertical or horizontal *lugs*. Profiles vary and should be classified in the same way as BOWLS (see 5.1.1-5.1.7).

HANDLED BOWLS should be classified by the **number of *handles***:

- 5.2.1      **Single-handled Bowl**
- 5.2.4      **Double-handled Bowl**
- 5.2.5      **Multi-handled Bowl**

Some forms employ a specific **type of *handle***:

- 5.2.2      **Socketed Bowl**
- 5.2.3      **Basket-handled Bowl**

Alternative names for handled bowls generally reflect function:

- Bleeding Bowl
- Porringer
- Stool Pan (see 5.2.1)

## 5.2 HANDLED BOWL

## Handled Bowl Forms

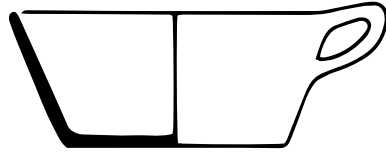

single-handled

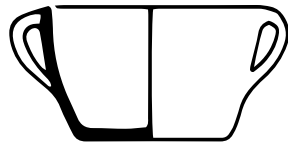

double-handled

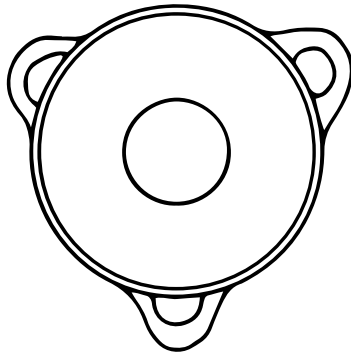

multi-handled

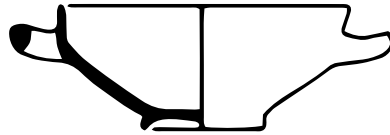

socketed

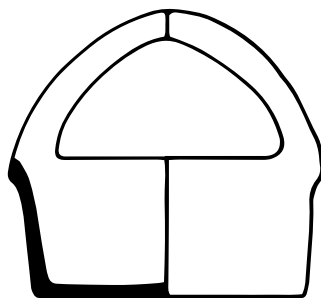

basket-handled

### 5.2.1 HANDLED BOWL

#### Single-handed Bowl

**Defining characteristics:** A bowl adapted by the addition of a single *handle*. Profiles vary and should be classified in the same way as BOWLS (see 5.1.1-5.1.7).

**Alternative names:** Bowls with *straight socketed handles* are generally referred to as SOCKETED BOWLS (see 5.2.2).

Small single-handed bowls may fall within the range of CUPS (see 6.2).

A more specialised form is the FRYING PAN (see 5.5). Large, single-handed, flared bowls, of medium depth to deep, with right-angled *everted rims* and vertical *loop handles* (see e, below), may be called Stool Pans, indicating possible function.

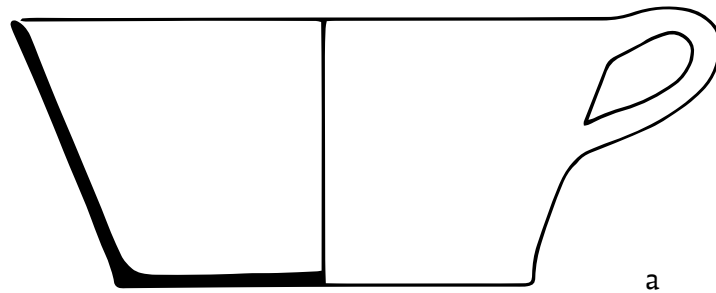

a

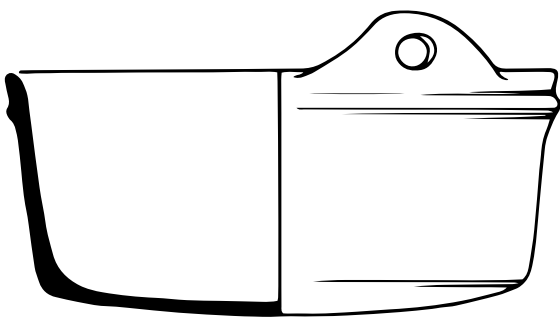

b

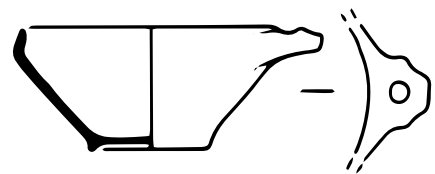

c

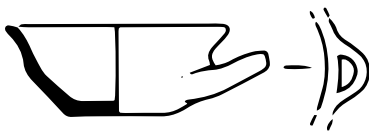

d



e

## 5.2.2 HANDLED BOWL

## Socketed Bowl

**Defining characteristics:** A bowl with a *straight handle* projecting horizontally or diagonally upwards from the rim, partially or completely hollow, but not opening into the vessel. Profiles vary and should be classified in the same way as BOWLS (see 5.1.1-5.1.7).

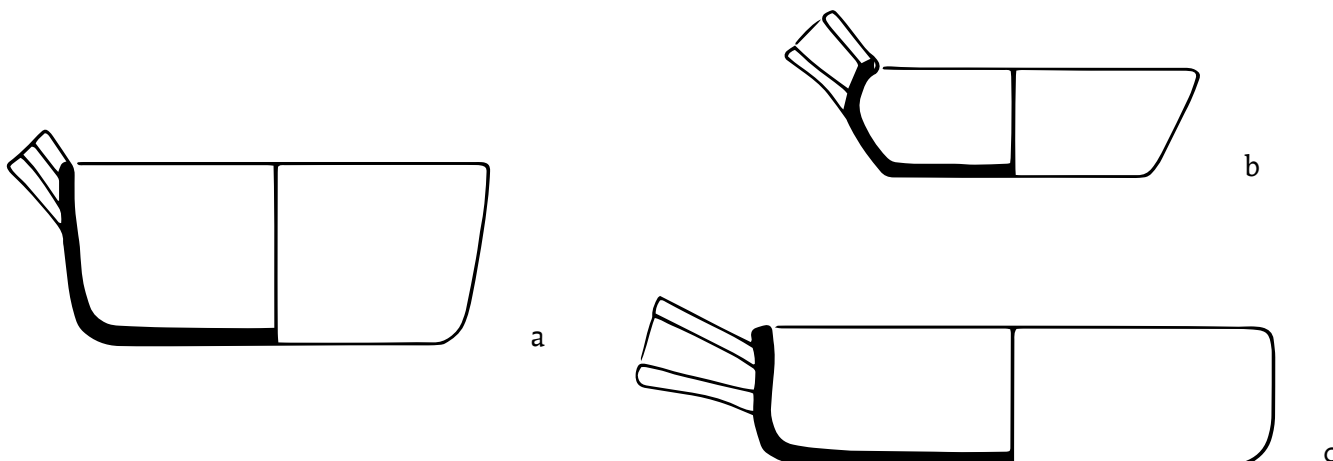

## 5.2.3 HANDLED BOWL

## Basket-handled Bowl

**Defining characteristics:** A bowl with a single *loop handle* crossing over the top of the vessel from one side of the rim to the other. Profiles vary and should be classified in the same way as BOWLS (see 5.1.1-5.1.7).

**Alternative name:** Basket.

Small examples may represent individual units of Condiment Bowls or MULTIPLE BOWLS (see 5.1.12).

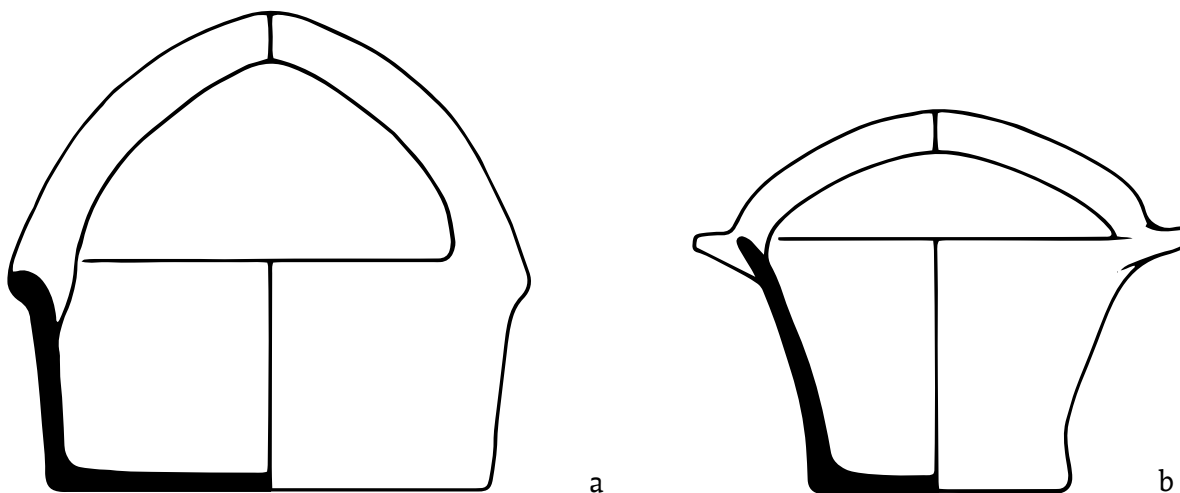

## 5.2.4 HANDLED BOWL

### Double-handled Bowl

**Defining characteristics:** A bowl adapted by the addition of two *handles*, generally opposed. Profiles vary and should be classified in the same way as BOWLS (see 5.1.1-5.1.7).

**Alternative names:** Two-handled Bowl.

Small examples may fall within the range of CUPS (see 6.2).

The term Cockerel Bowl should only be used for those small, double-handled bowls with horizontal *loop handles*, decorated with a cockerel motif (see e, below).

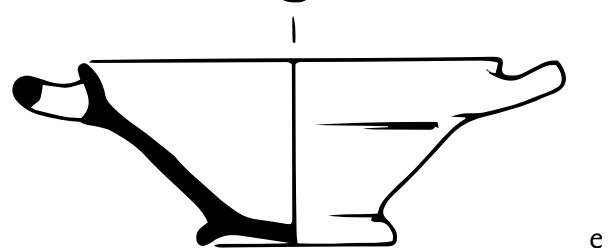
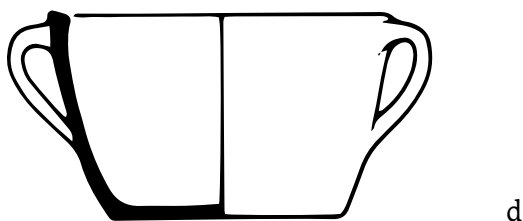
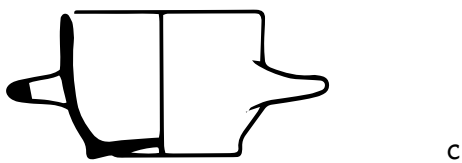
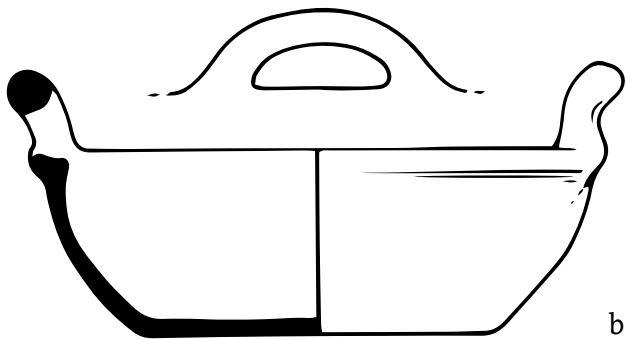
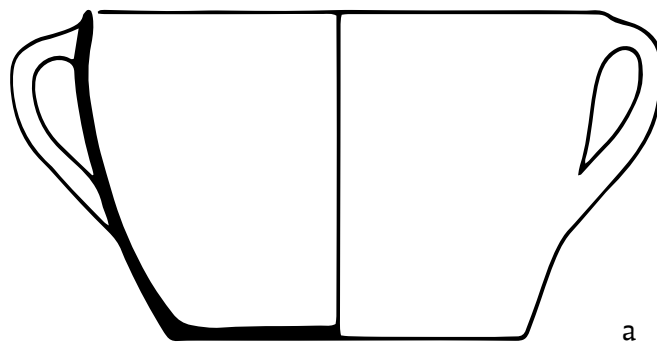

### 5.2.5 HANDLED BOWL

### Multi-handled Bowl

**Defining characteristics:** A bowl adapted by the addition of three or more *handles*. Profiles vary and should be classified in the same way as BOWLS (see 5.1.1-5.1.7).

**Alternative names:** Three-handled Bowl, Four-handled Bowl, etc.

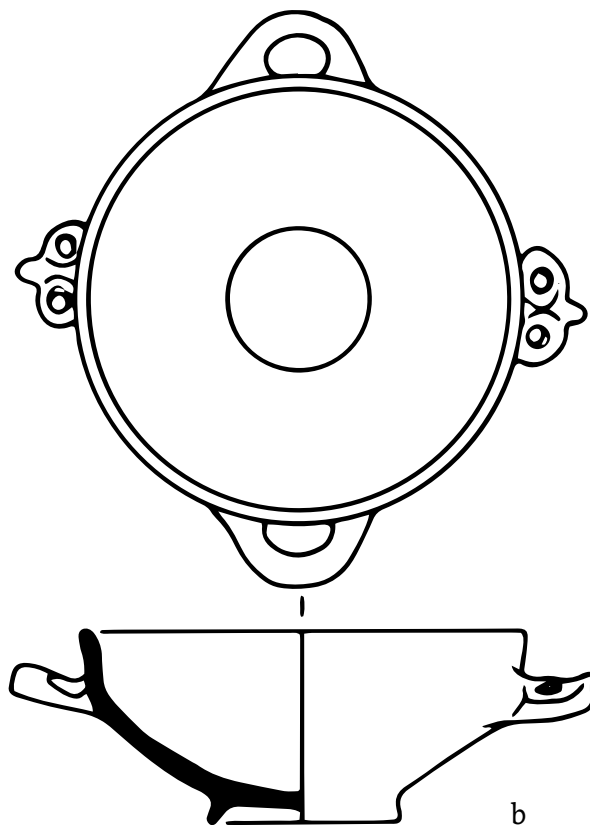
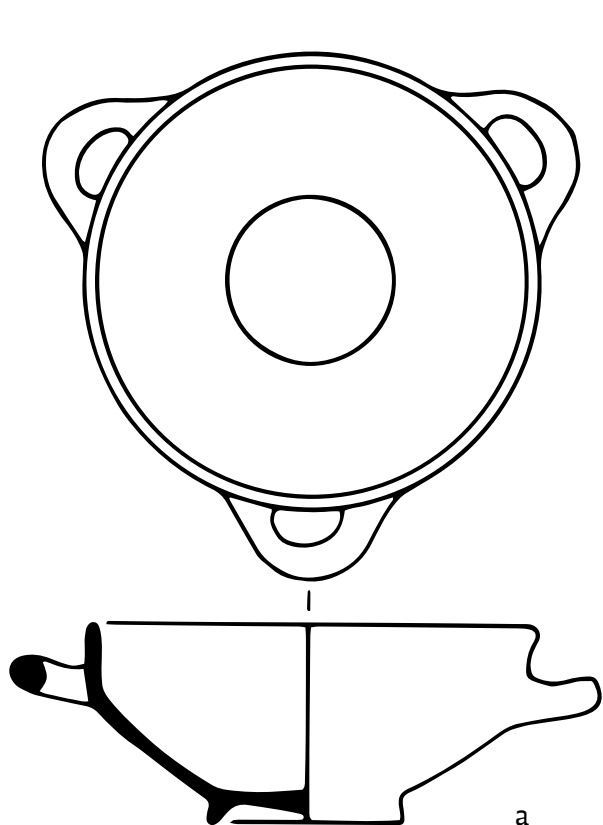



## 5.3 DISH

**Defining characteristics:** This term is frequently used interchangeably with the term BOWL to refer to open forms. Where a distinction is made, it is on the basis of **depth**, with dishes defined as shallower vessels than bowls. Shallow examples, particularly oval or rectangular, may be termed Trays. A closer definition is proposed here on the basis of terminology used for Romano-British pottery (Webster 1976, 17-18; Orton 1980, 34) and also employed for, amongst others, Surrey/Hampshire Border wares (Pearce 1992). This terminology defines a DISH as an open vessel with a height of between one-third and one-seventh of its rim diameter.

Within these parameters DISHES cover a wide variety of shapes and sizes. Rim forms are equally varied, but with the exception of certain specialised forms (see **Inturned Dish: 5.3.1**), rim diameter is always greater than base diameter. Criteria for classification are suggested here.

DISHES are classified by **profile**, in the same way as BOWLS (see 5.1.1-5.1.7), with one addition:

### 5.3.1 Inturned Dish

Dishes may be further subdivided by **size** (but see **Section 1.3.2**). Small dishes have been called Saucers, but this is not recommended.

Dishes can be of varying **shape in plan**:

### 5.3.3 Lobed Dish

Rectangular or oval dishes, particularly **shallow** examples, may be called Trays. Particular shapes are suited to specific functions:

### 5.3.6 Dripping Dish

Dishes may be adapted by the addition of *handle(s)* and/or *feet*, or other more elaborate *component parts*:

### 5.3.2 Pedestal Dish

### 5.5 Frying Pan

### 5.5.1 Skillet

or by **piercing**:

Incurved Dish (see 5.3.1)

'West Country' Dish (see 5.3.1)

or by **division** or **multiplication**:

### 5.3.4 Divided Dish

### 5.3.5 Multiple Dish

### 5.3.1 DISH

### Inturned Dish

**Defining characteristics:** A dish with straight or convex sides that turn inwards, forming an acute basal angle.

**Alternative names:** A specific form of Inturned Dish, adapted by the piercing of the body wall with one or more holes, usually just above the base, is the Incurved Dish (see c, below), with a restricted distribution mainly in South Wales (see Sell 1984).

The 'West Country' Dish is a variant of the Incurved Dish; the name reflects its distribution (see d, below). These vessels are necked, and the upper part of the vessel, without the distinctive basal angle, may be mistaken for a JAR (see 4.1). Deeper examples may be difficult to distinguish from the squat INTURNED JAR ('Peat Pot': see 4.1.6); note that the distributions of the two types are widely different.

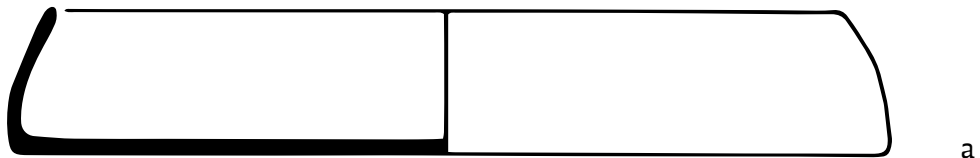

a

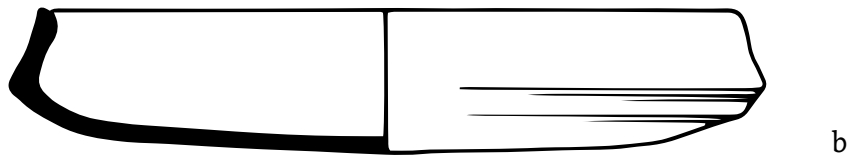

b

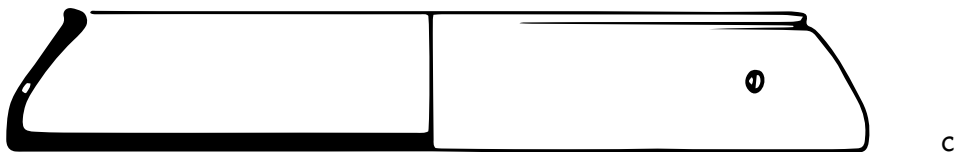

c

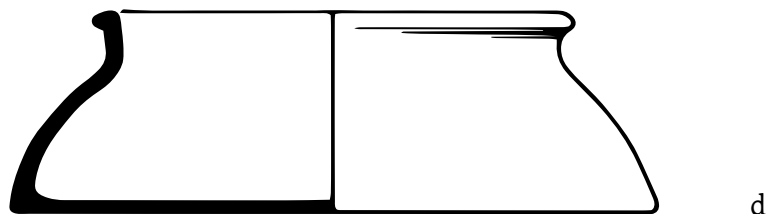

d

## 5.3.2 DISH

## Pedestal Dish

**Defining characteristics:** A dish adapted by the addition of a *pedestal base*. Profiles vary and should be classified in the same way as BOWLS (see 5.1.1-5.1.7).

**Alternative names:** These vessels have sometimes been described as Pedestal Salts or Cup Salts, especially on the Continent, or as Sweetmeat Dishes. Ornate examples, particularly Continental, may be called *Tazze* (sing. *Tazza*) (see also PEDESTAL BOWL: 5.1.9).

Smaller examples may fall into the category of PEDESTAL BEAKERS (see 6.1.1).

With the addition of a *handle*, the smaller examples become PEDESTAL CUPS (see 6.2.5).

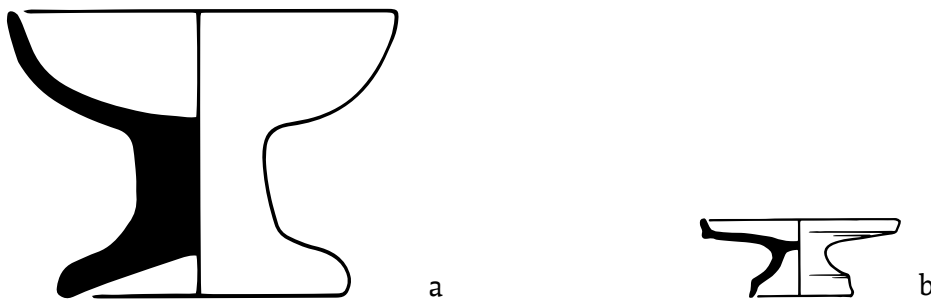

## 5.3.3 DISH

## Lobed Dish

**Defining characteristics:** A dish comprising three or more *lobes*, usually equally spaced. There may be one or more moulded animal or other figures inside the base (see 12.1: Zoomorphic applied decoration). There may be two or more *handles*. Profiles vary and should be classified in the same way as BOWLS (see 5.1.1-5.1.7).

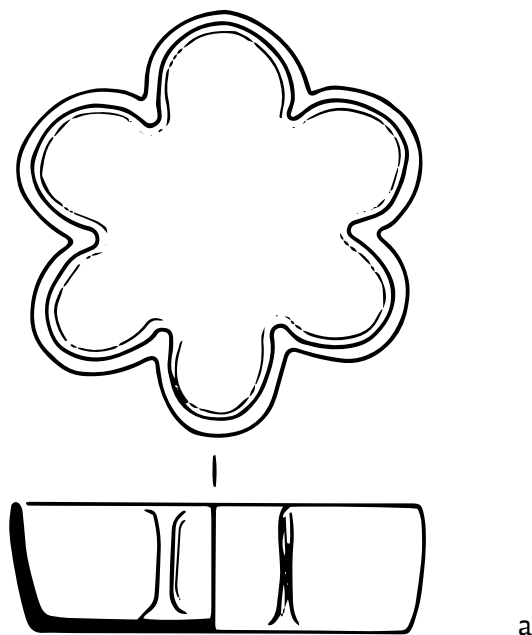

## 5.3.4 DISH

## Divided Dish

**Defining characteristics:** Round, oval or rectangular straight-sided dish, divided into two or more units or compartments of varying sizes by vertical slab *partitions*.

**Alternative names:** Condiment Dish has been used.

Dishes with multiple units may be called Compartmented Trays (see c, below) some of which may have been used as Culinary Moulds.

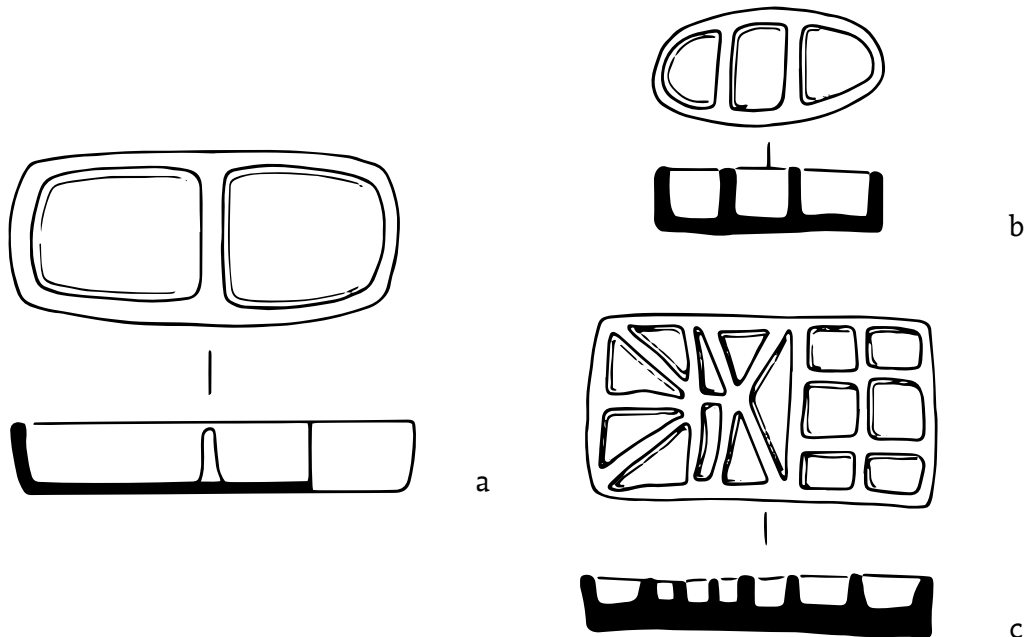

## 5.3.5 DISH

## Multiple Dish

**Defining characteristics:** A vessel comprising two or more dishes, generally of small size, joined together. Profiles vary and should be classified in the same way as BOWLS (see 5.1.1-5.1.7). There may be one or more *handle(s)* of varying forms.

**Alternative name:** Condiment Dish has been used.

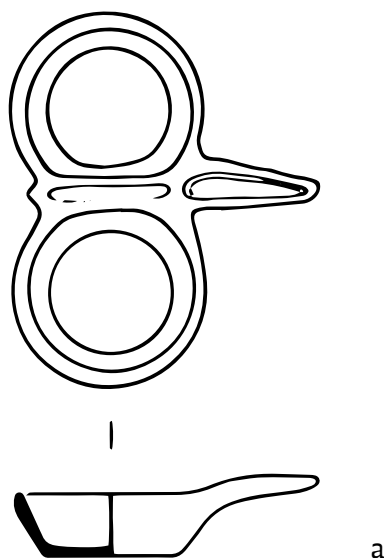

## 5.3.6 DISH

## Dripping Dish

**Defining characteristics:** A type of dish specifically designed to catch the juices from roasting meat. The dish can be oval, semi-circular, rectangular or wedge-shaped. There are generally one or two *handles*, *solid* or *socketed*, located on one long side, and a *lip* at one or both short ends. There may be a *foot* or *feet* on the side below the handle(s), to tip the vessel towards the fire. Profiles vary and should be classified in the same way as BOWLS (see 5.1.1-5.1.7).

**Alternative names:** Dripping Pan, Dripping Tray, Baking Tray, Meat Dish, Fish Dish.

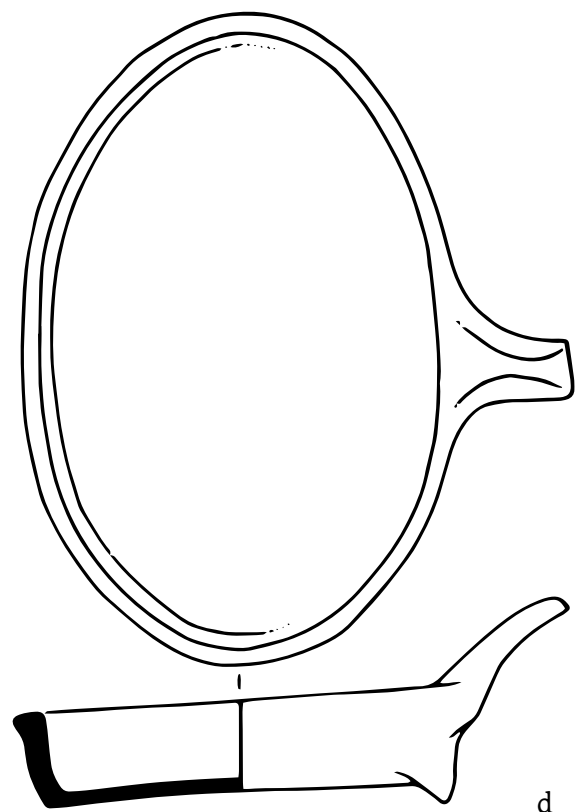
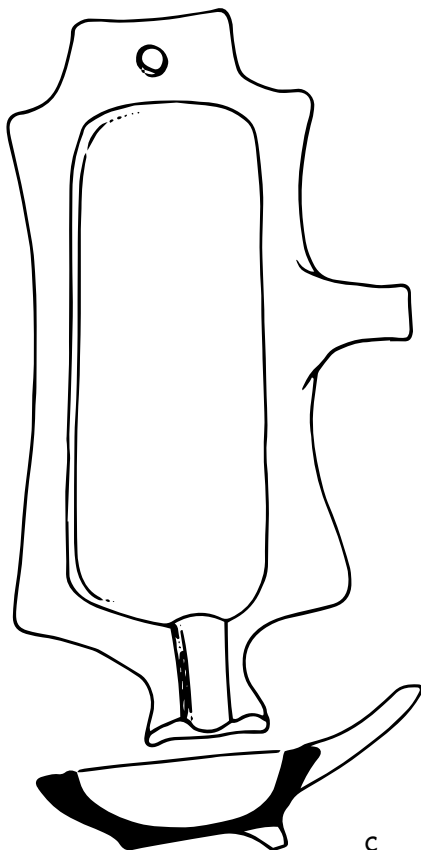
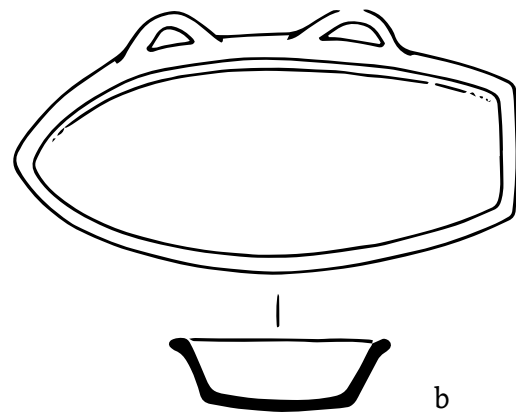
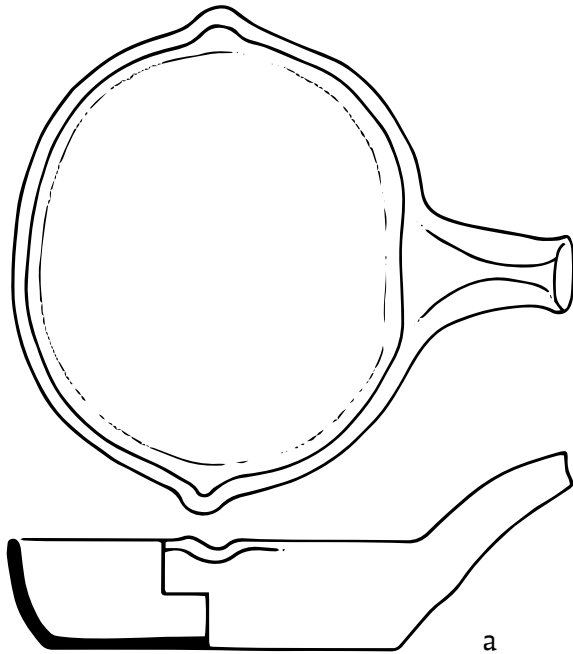

## 5.4 PLATE

**Defining characteristics:** The term PLATE is rarely defined consistently but is frequently used to describe shallow DISHES or flatwares. Strictly speaking, the term plate should not be employed for medieval vessels, but should be restricted to those post-medieval vessels which have a more obvious similarity to modern plates. These are defined, for example for tin-glazed wares, as vessels with a height of less than one-fifth of their rim diameter, in which the upper part of the wall is everted (Bloice and Dawson 1971, 121).

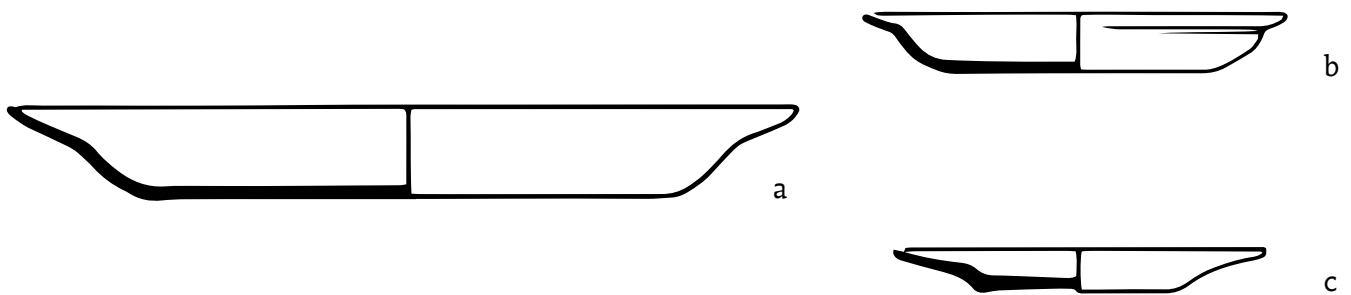

## 5.5 FRYING PAN

**Defining characteristics:** A bowl or dish adapted by the addition of a *straight handle* extending from the rim. The handle may be solid or tubular. There may be a *lip* at 90° to the handle. The handle may have a supporting *strut*; some examples have vertical *loop handles*. Profiles vary and should be classified in the same way as BOWLS (see 5.1.1-5.1.7).

A frying pan may be adapted by the addition of three *feet*:

### 5.5.1 Skillet

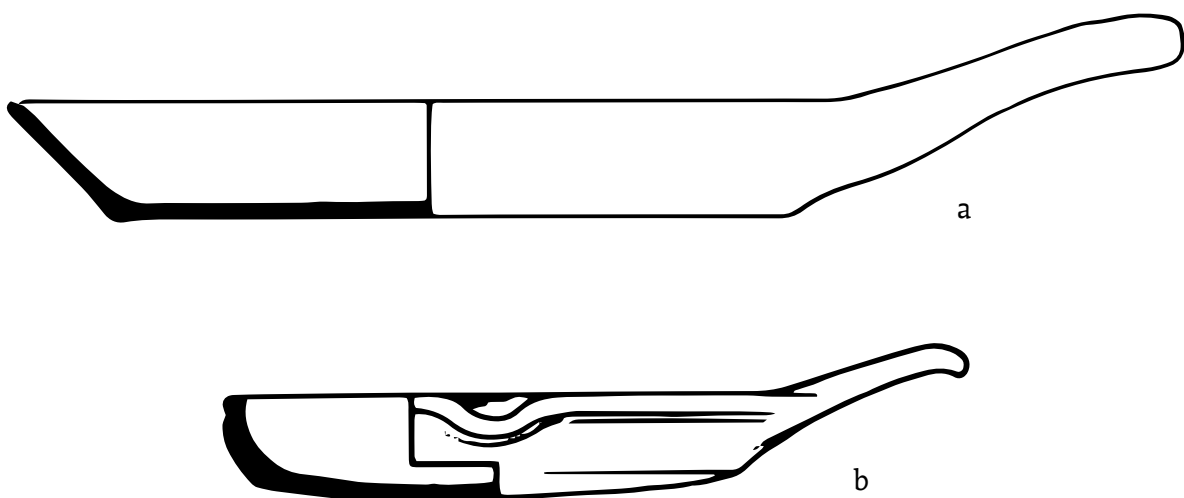

### 5.5.1 FRYING PAN

### Skillet

**Defining characteristics:** A bowl or dish with a *straight handle* and three applied *feet*. The handle may be solid or tubular; there may be a *lip* at 90° to the handle. Feet may be thumbed rather than applied. Profiles vary and should be classified in the same way as BOWLS (see 5.1.1-5.1.7).

**Alternative name:** Large, deep examples may be termed Saucepans.

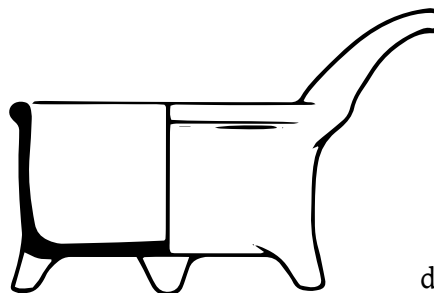
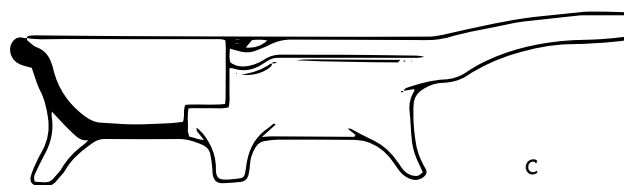
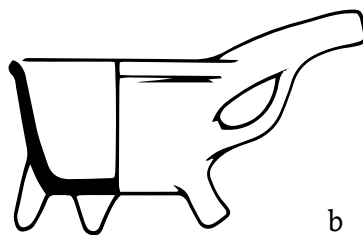
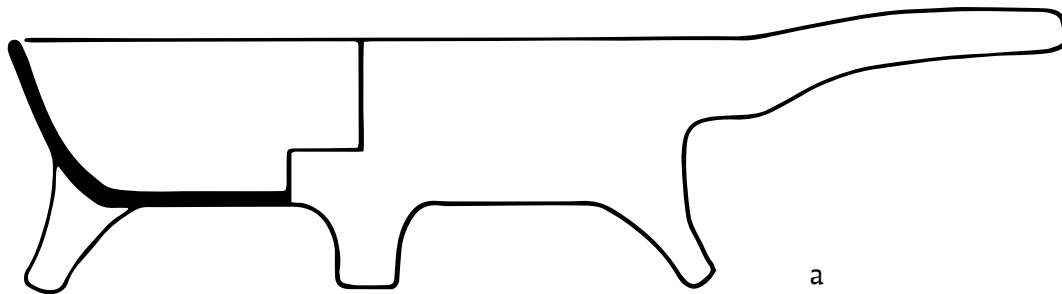

## SECTION 6: DRINKING VESSELS

---

### Contents

#### Introduction to DRINKING VESSELS

##### 6.1 BEAKER

- 6.1.1 Pedestal Beaker
- 6.1.2 Rounded Beaker
- 6.1.3 Waisted Beaker

##### 6.2 CUP

- 6.2.1 Carinated Cup
- 6.2.2 Flared Cup
- 6.2.3 Necked Cup
- 6.2.4 Rounded Cup
- 6.2.5 Pedestal Cup
- 6.2.6 Lobed Cup
- 6.2.7 Fuddling Cup
- 6.2.8 Puzzle Cup

##### 6.3 MUG

- 6.3.1 Barrel-shaped Mug
- 6.3.2 Conical Mug
- 6.3.3 Cylindrical Mug
- 6.3.4 Flared Mug
- 6.3.5 Rounded Mug

#### Introduction to DRINKING VESSELS

Vessels which were designed specifically for drinking are rare before the later medieval period. In earlier periods, small BOWLS may have been used (see 5.1), but even these vessels are not common finds, and drinking vessels were more likely to have been made in other materials such as wood. Small JARS may be described as BEAKERS, with an implied drinking function (see 4.1). Drink could also be taken straight from a JUG (see for example, McCarthy and Brooks 1988, fig. 51), or from a FLASK or COSTREL (see 3.3 and 10.7). In the later medieval period small jugs, termed Drinking Jugs, become common (see 3.1), and these may overlap with the category of CONICAL MUGS.

More specialised drinking vessels appeared from the 15th century, particularly in the 'Tudor Green' and Cistercian ware traditions, and these were designed either for individual drinking (BEAKERS, CUPS, MUGS) or for communal use (FUDDLING CUPS, LOBED CUPS).

In general, drinking vessel forms are classified in the same way as JARS or JUGS for the enclosed forms (e.g. MUGS) and as BOWLS for the open forms (e.g. CUPS). It should be noted that some of the terms for drinking vessel forms (such as waisted) are used differently in other parts of the Guide.

Note also that the names BEAKER, Goblet, CUP, MUG and Tankard often overlap and frequently reflect regional and period bias rather than definable differences in shape.



## 6.1 BEAKER

**Defining characteristics:** A drinking vessel without a handle, with the height generally greater than the maximum diameter. Forms may be either open or closed and so may overlap with smaller examples of both JARS and BOWLS; the distinction is made purely on the basis of size, which can be fairly arbitrary. Profiles should therefore be classified in the same way as JARS (see 4.1.1-4.1.8) or BOWLS (see 5.1.1-5.1.7).

BEAKERS may also be adapted by the addition of a *pedestal base* or by constricting the lower part of the body to form a 'waist':

6.1.1 Pedestal Beaker

6.1.2 Rounded Beaker

6.1.3 Waisted Beaker

Alternative name: Goblet has been used.

## 6.1 BEAKER

## Beaker Profiles

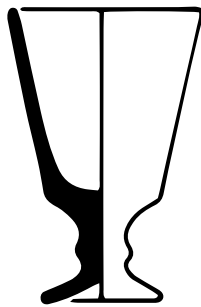

pedestal beaker

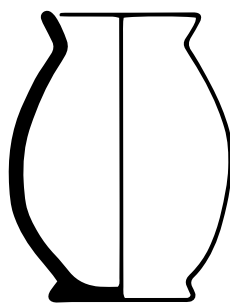

rounded beaker

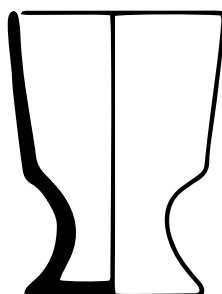

waisted beaker

### 6.1.1 BEAKER

#### Pedestal Beaker

**Defining characteristics:** A beaker adapted by having a *pedestal base*. The upper part of the pedestal is solid and may be thrown as an integral part of the vessel, or added as a separate element. Profiles vary and should be classified in the same way as JARS (see 4.1.1-4.1.8) or BOWLS (see 5.1.1-5.1.7), e.g. rounded (b) or flared (a).

**Alternative names:** Stemmed Beaker, Stemmed Goblet have been used.

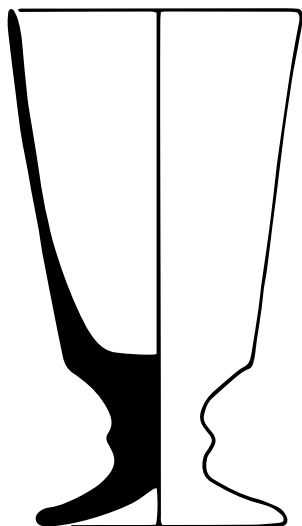

a

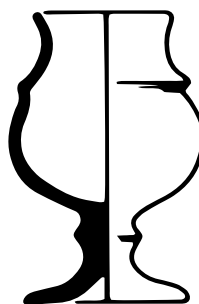

b

### 6.1.2 BEAKER

#### Rounded Beaker

**Defining characteristics:** A beaker with convex body walls.

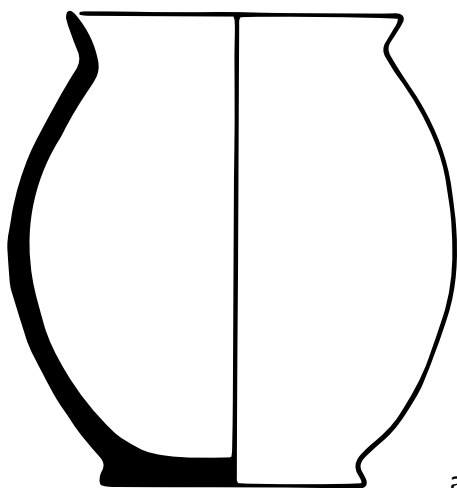

a

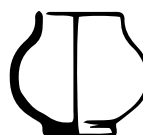

b

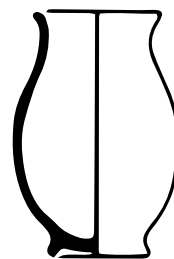

c

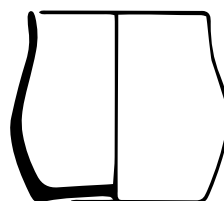

d

### 6.1.3 BEAKER

### Waisted Beaker

**Defining characteristics:** A beaker with a constriction above the base to form a waisted profile. Profiles vary and should be classified in the same way as JARS (see 4.1.1-4.1.8) or BOWLS (see 5.1.1-5.1.7), e.g. flared (a and b), rounded (d) or cylindrical (e).

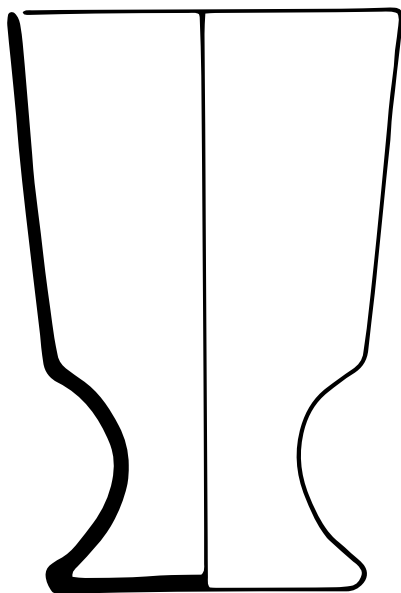

a

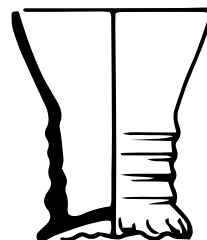

b

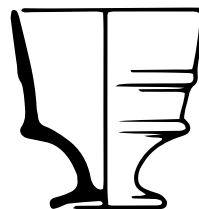

c



d

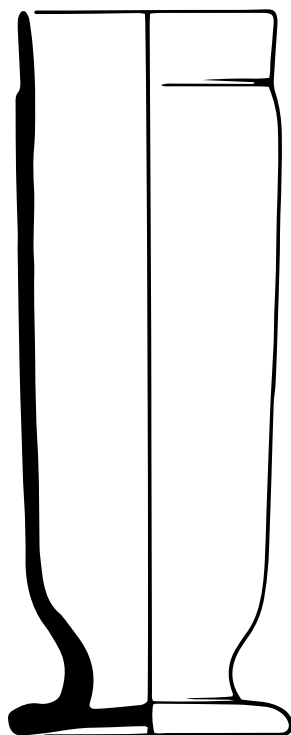

e

## 6.2 CUP

**Defining characteristics:** The term CUP has often been used to describe any small drinking vessel, which could potentially include small BOWLS (without handles), sometimes termed Drinking Bowls (see 5.1). A more rigorous definition is recommended here, of a squat drinking vessel, with the rim diameter always greater than both the base diameter and the height, and with vertical *loop handle(s)*. Cups should be classified by **profile** in the same way as BOWLS (see 5.1.1-5.1.7); four of the most common profiles are:

- 6.2.1 Carinated Cup
- 6.2.2 Flared Cup
- 6.2.3 Necked Cup
- 6.2.4 Rounded Cup

Cups may be adapted by the addition of a more ornate *base*:

- 6.2.5 Pedestal Cup

or by the addition of more than one *handle*:

- Double- (or Two-handled) Cup
- Multi- (or Three-handled) Cup, etc.

or may be made to a more specialised design:

- 6.2.6 Lobed Cup
- 6.2.7 Fuddling Cup
- 6.2.8 Puzzle Cup

## 6.2 CUP

## Cup Profiles

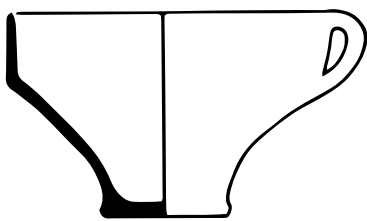

carinated cup

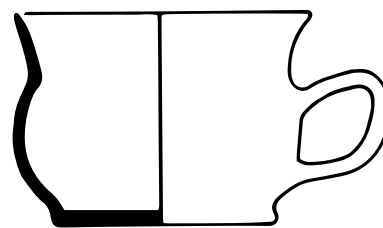

necked cup

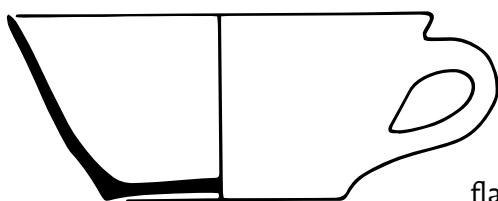

flared cup

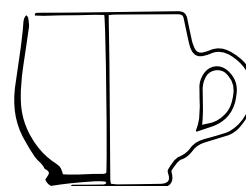

rounded cup

### 6.2.1 CUP

#### Carinated Cup

**Defining characteristics:** A cup with a marked change of angle in the body wall, generally at the point of maximum girth.

**Alternative name:** Collar Rim Cup has been used.

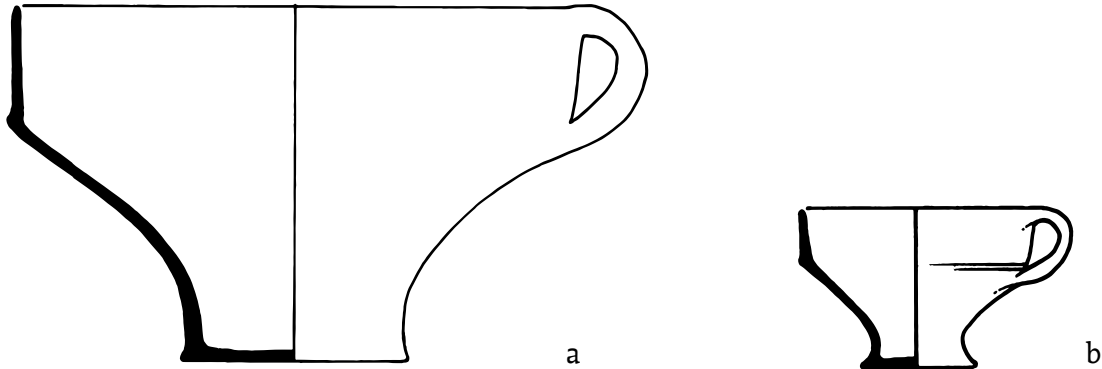

### 6.2.2 CUP

#### Flared Cup

**Defining characteristics:** A cup with sides flaring outwards from the base towards the rim, usually with a single *handle*.

This form should be further subdivided into **straight-sided** and **concave-sided** if required.

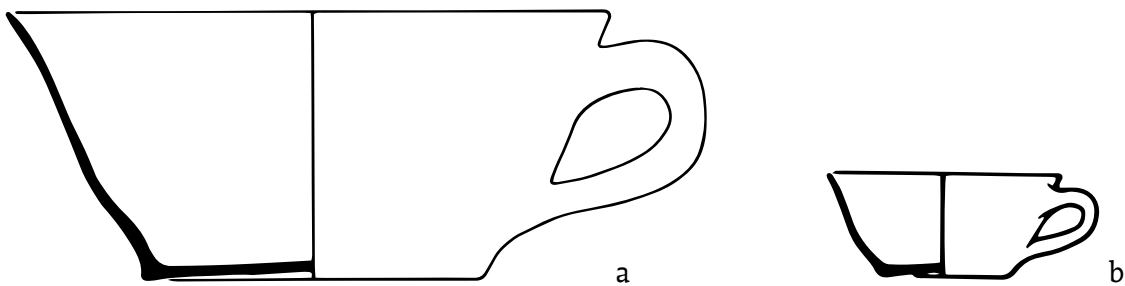

### 6.2.3 CUP

### Necked Cup

**Defining characteristics:** A cup with a rounded body beneath a deep neck. There may be a marked junction between neck and body.

The angle of the neck may be **inward-sloping**, **upright** or **everted**.

**Alternative name:** Thistle Tyg.

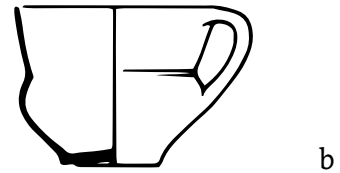
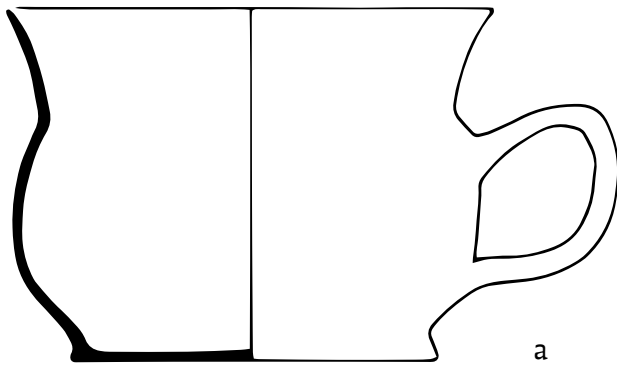

### 6.2.4 CUP

### Rounded Cup

**Defining characteristics:** A cup with convex body walls.

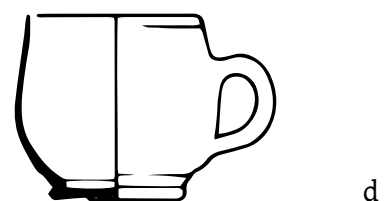
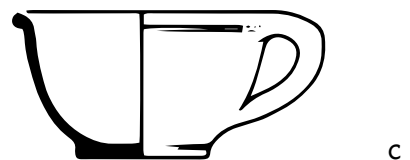
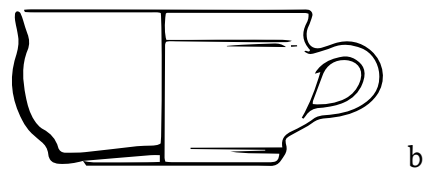
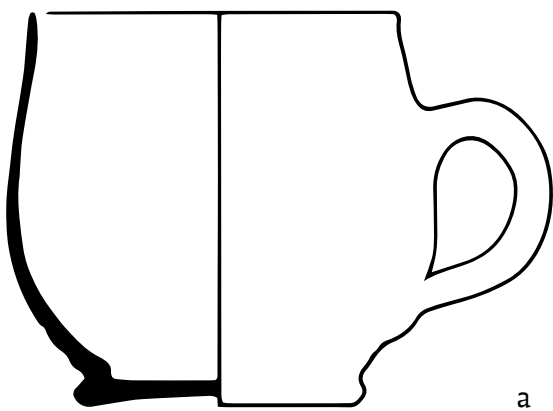

## 6.2.5 CUP

## Pedestal Cup

**Defining characteristics:** A cup adapted by the addition of a *pedestal base*. Profiles vary and should be classified in the same way as BOWLS (see 5.1.1-5.1.7).

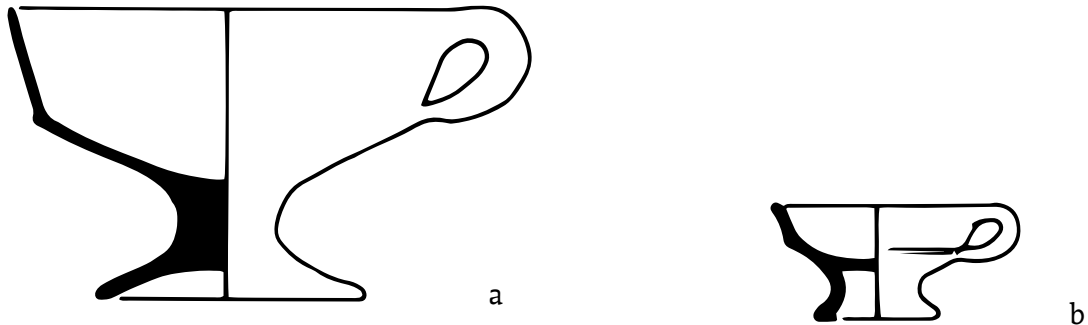

## 6.2.6 CUP

## Lobed Cup

**Defining characteristics:** A vessel composed of three or more equally spaced *lobes* and usually, a waisted or *pedestal base*. The *handles* are vertical loops, generally of strap form. There may be two opposed handles, or one per lobe junction. There may be moulded animal or other figures inside the cup (see 12.1: Applied decoration).

The distinction between LOBED CUPS and LOBED BOWLS (see 5.1.10) may not always be apparent, but Lobed Bowls generally have a *flat base*, whereas Lobed Cups usually have a narrow waisted or *pedestal base*.

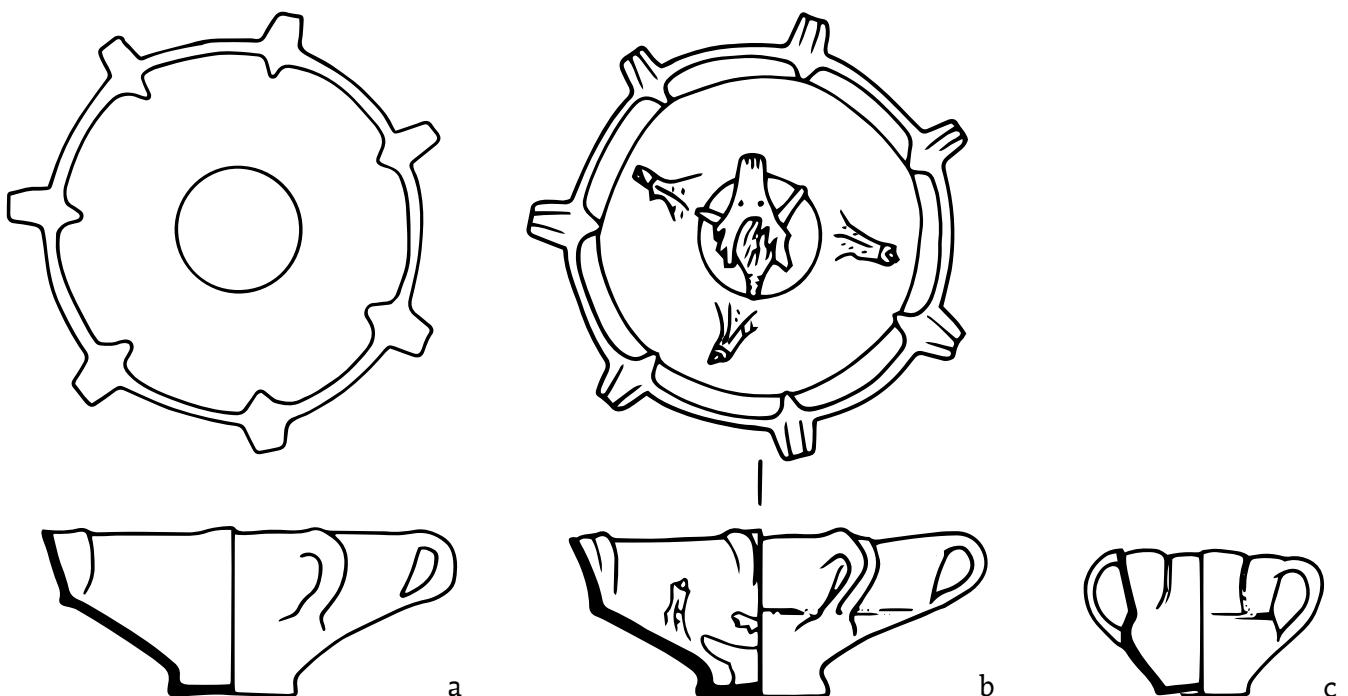

### 6.2.7 CUP

### Fuddling Cup

**Defining characteristics:** A vessel composed of three or more separate compartments, joined together and pierced to allow liquid to flow from one to another. There may be one or more *handles*. The form of the compartments varies and should be related to the most appropriate cup or mug form.

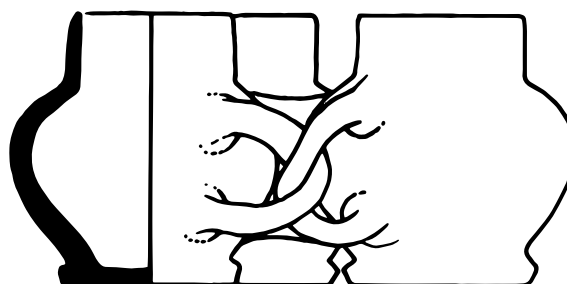
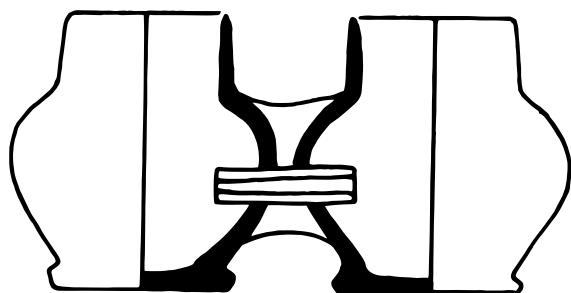
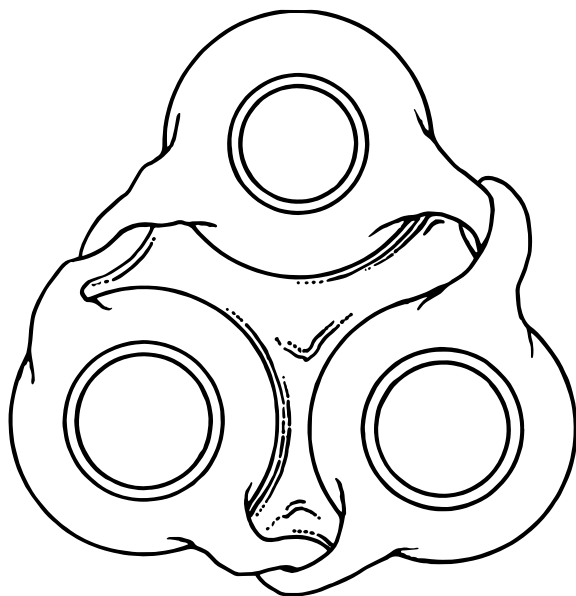



## 6.2.8 CUP

### Puzzle Cup

**Defining characteristics:** A form of CUP which constitutes a joke or conundrum, where *cut-outs* or holes in the body make conventional use impossible. The puzzle is how to drink from it without being drenched; success is usually achieved by sucking up the liquid through the connecting hollow *rim* and *handle*.

Purpose-made Puzzle Cups are rare forms in the late medieval period. Post-firing alterations to existing vessels are also known and are slightly more common.

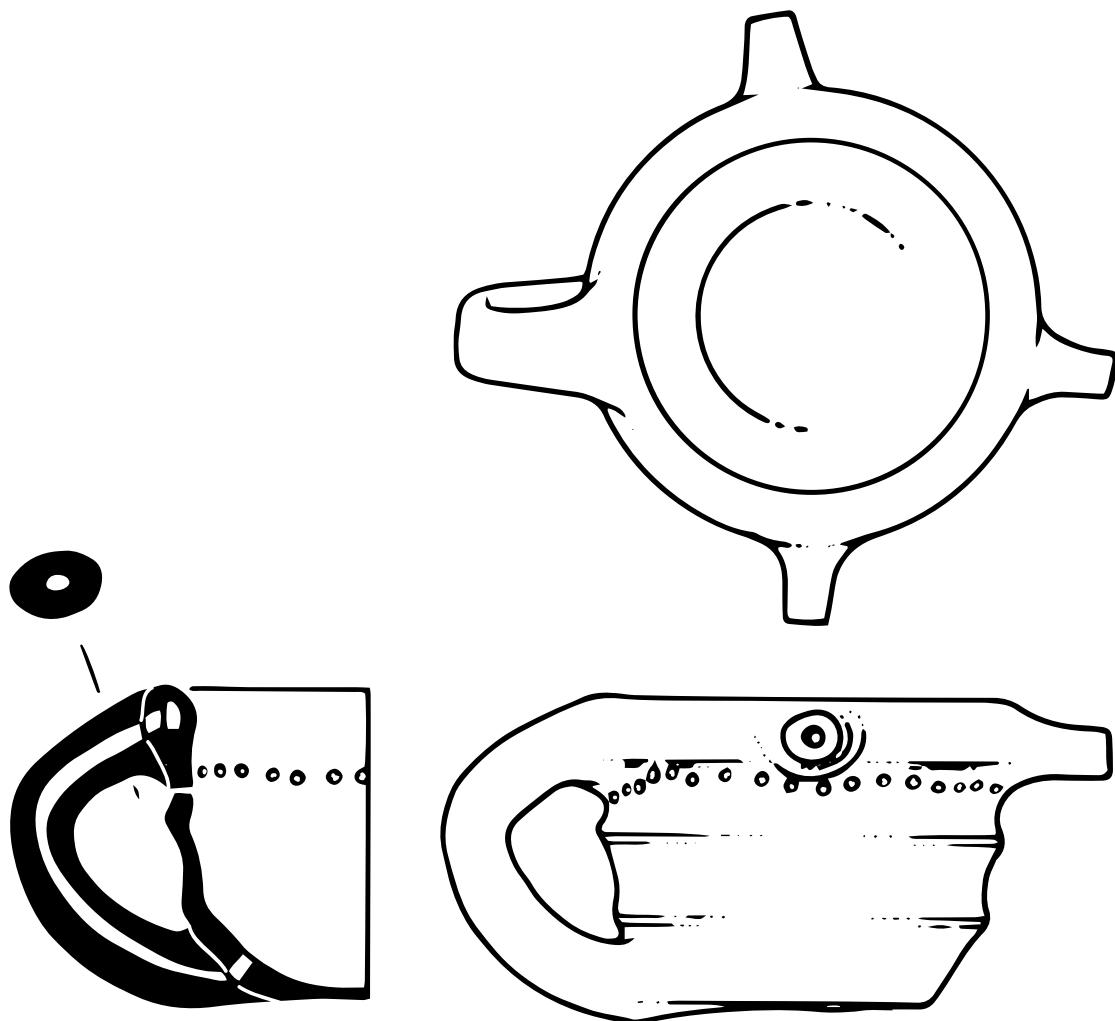

## 6.3 MUG

**Defining characteristics:** A tall drinking vessel with vertical *loop handle(s)*. The height is greater than the rim, base and maximum diameters. Commonly, the top of the handle is attached just below the rim. Some have two *handles*, opposed or placed close together on one side; others have more than two *handles*, equally spaced around the body.

**Alternative name:** Tankard has been used for a mug with a large capacity.

MUGS are classified by *profile*:

- 6.3.1 Barrel-shaped Mug
- 6.3.2 Conical Mug
- 6.3.3 Cylindrical Mug
- 6.3.4 Flared Mug
- 6.3.5 Rounded Mug

## 6.3 MUG

## Mug Profiles

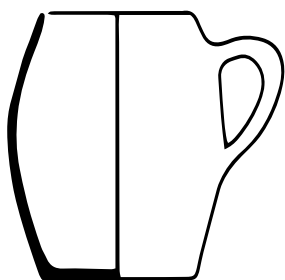

barrel-shaped mug

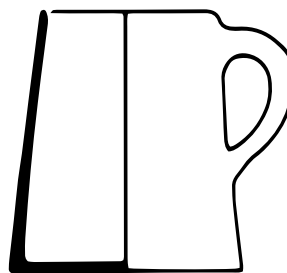

conical mug

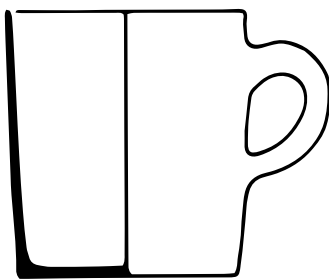

cylindrical mug

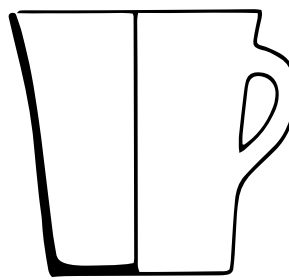

flared mug

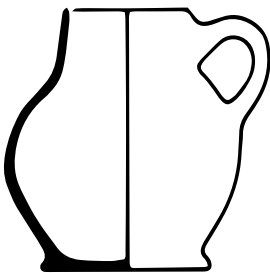

rounded mug

### 6.3.1 MUG

#### Barrel-shaped Mug

**Defining characteristics:** A mug with little or no discernible neck and an even, convex profile from rim to base, which have roughly equal diameters.

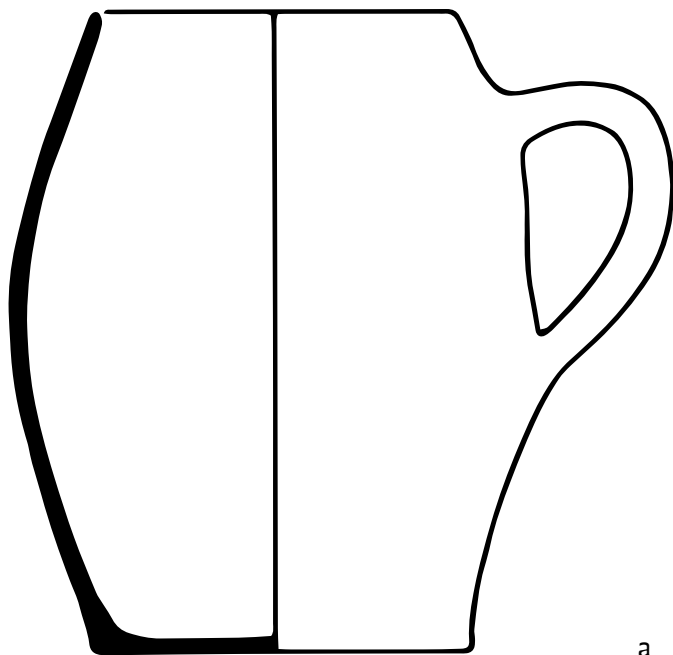

a

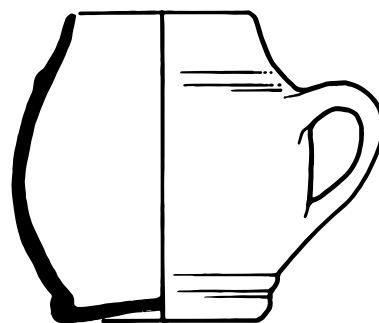

b



c

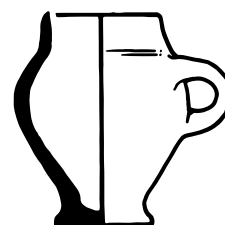

d

### 6.3.2 MUG

### Conical Mug

**Defining characteristics:** A mug with more-or-less straight sides which flare out from the rim to the wider base. This form may overlap with small CONICAL JUGS (see 3.1.4).

**Alternative names:** Tankard has been used, in particular for tall versions, often with metal lids.

The term *Schnelle* (pl. *Schnellen*) should be used only for German stoneware forms.

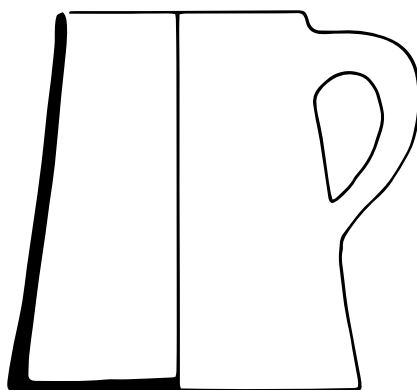

a

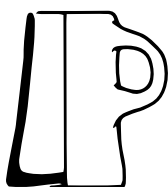

b

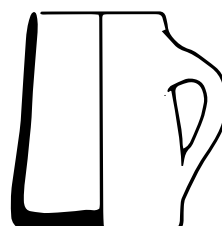

c



d

### 6.3.3 MUG

### Cylindrical Mug

**Defining characteristics:** A mug with roughly vertical body walls.

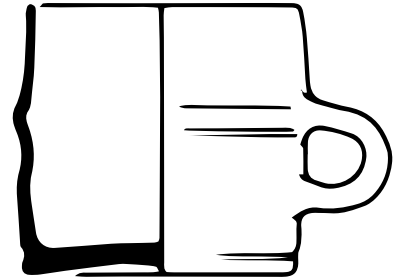
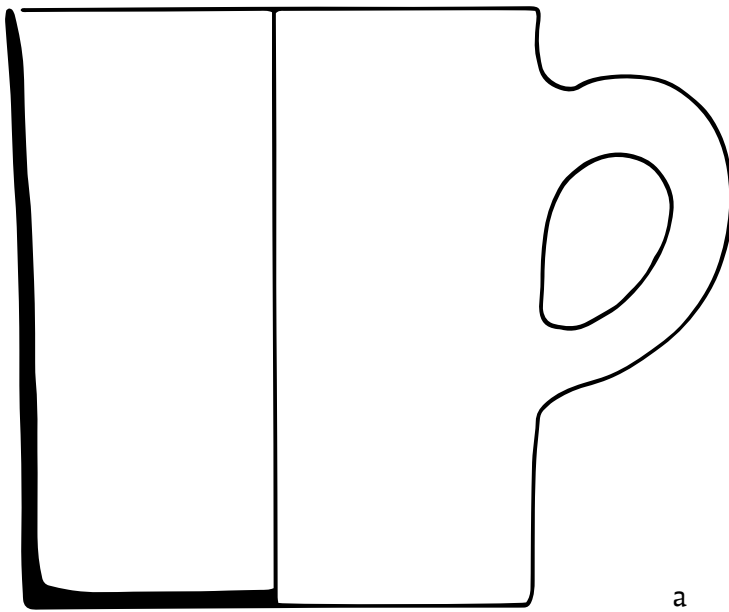

### 6.3.4 MUG

### Flared Mug

**Defining characteristics:** A mug with straight sides flaring outwards from the base towards the rim.

**Alternative name:** Examples with two or more handles have been called Tygs (see e, below).

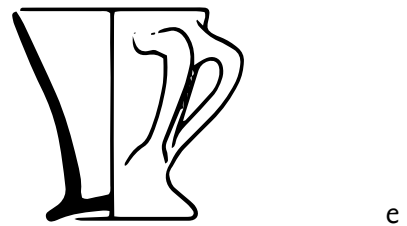
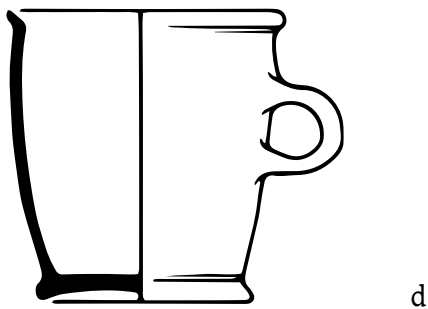
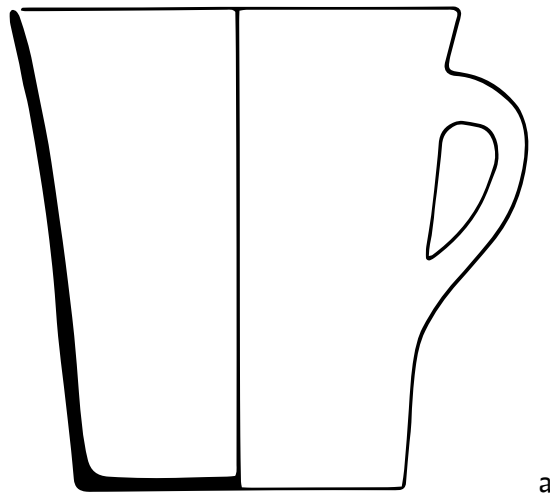

## 6.3.5 MUG

## Rounded Mug

**Defining characteristics:** A mug with a rounded body profile below a deep neck. There may be a marked junction between the neck and the body.

The angle of the neck may be inward-sloping, upright or everted.

**Alternative name:** A specific German stoneware form is termed *Trichterhalskrug* (literally, 'funnel-necked jug'; see e, below).

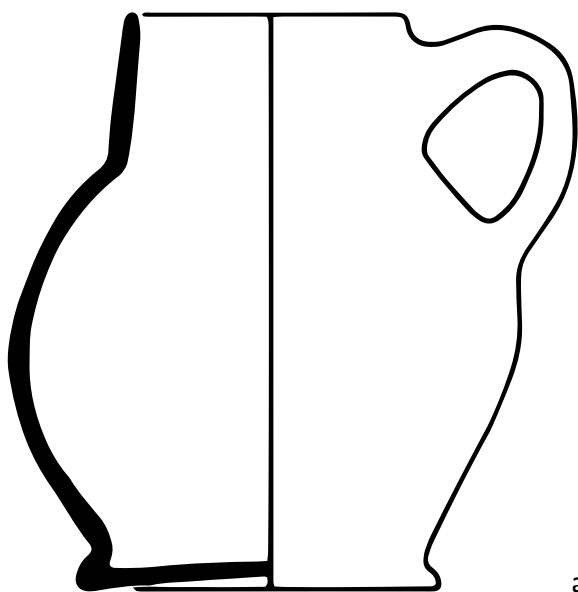

a

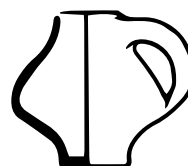

b



c



d

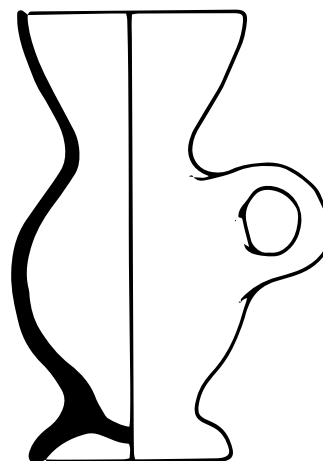

e

## SECTION 7: LIDS

---

### Contents

- 7.1 LID
  - 7.1.1 Collared Lid
  - 7.1.2 Conical Lid
  - 7.1.3 Dish Lid
  - 7.1.4 Domed Lid
  - 7.1.5 Flat Lid
  - 7.1.6 Flat-topped Lid
  - 7.1.7 Saucer-shaped Lid
  - 7.1.8 Flanged Lid
  - 7.1.9 Complex Lid

### 7.1 LID

**Defining characteristics:** In their simplest form, lids consist of inverted DISHES. For lifting, most examples have a raised central *knob* (or in some instances a *loop handle*). Where there is no knob, or the knob does not survive, they may be difficult to distinguish from DISHES.

LIDS are classified by **profile** (see below):

- 7.1.1 Collared Lid
- 7.1.2 Conical Lid
- 7.1.3 Dish Lid
- 7.1.4 Domed Lid
- 7.1.5 Flat Lid
- 7.1.6 Flat-topped Lid
- 7.1.7 Saucer-shaped Lid

These basic profiles can be adapted by the addition of a flange which, in the most elaborate examples, includes simple locking device:

- 7.1.8 Flanged Lid

Some lids are more complex and/or ornate, and do not fit easily into the above categories:

- 7.1.9 Complex Lid

Lids can also be described by their **shape in plan**, e.g. oval, rectangular.



## 7.1 LID

## Lid Profiles

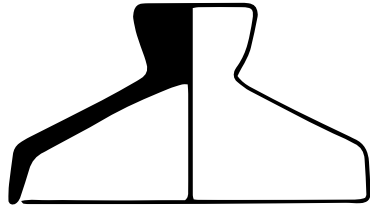

collared

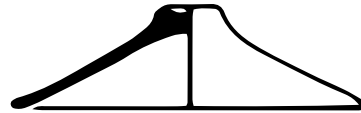

conical



dish

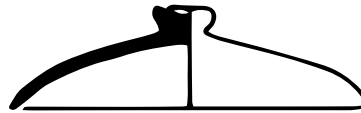

domed



flat

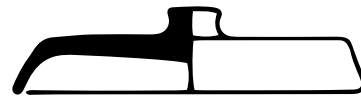

flat-topped



saucer-shaped

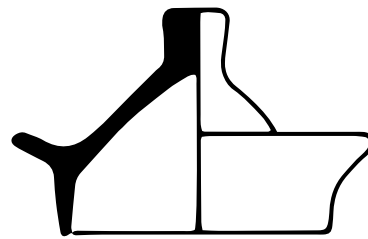

flanged

7.1.1 LID

Collared Lid

**Defining characteristics:** A lid with a carinated conical profile and straight vertical sides, surmounted by a conical top with an integral *knob*.

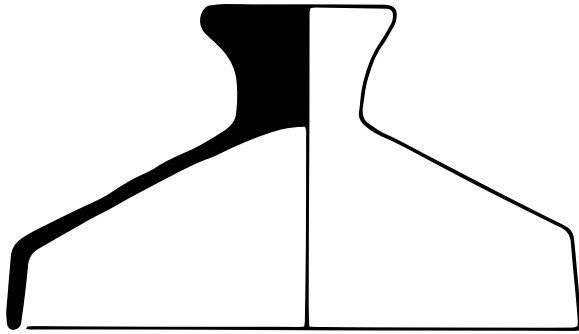

a

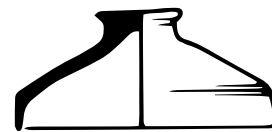

b

7.1.2 LID

Conical Lid

**Defining characteristics:** A lid with a shallow conical profile and an integral *knob*.

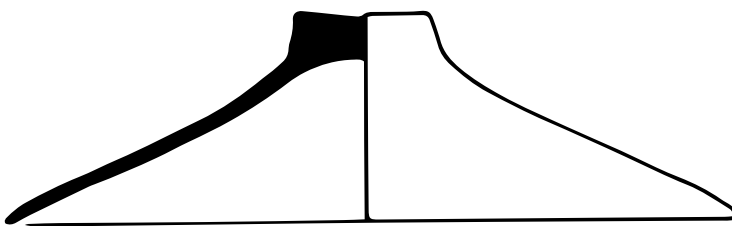

a

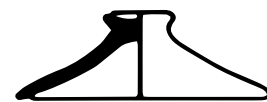

b



c



d

### 7.1.3 LID

### Dish Lid

**Defining characteristics:** A simple Flat-topped Lid (as 7.1.6), resembling an inverted DISH, but with no central *knob* or *handle*. Profiles vary and should be classified in the same way as DISHES (see 5.3).

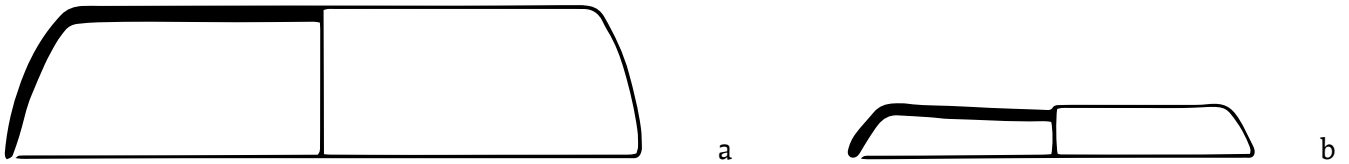

### 7.1.4 LID

### Domed Lid

**Defining characteristics:** A lid with a shallow domed profile and a central *knob*.

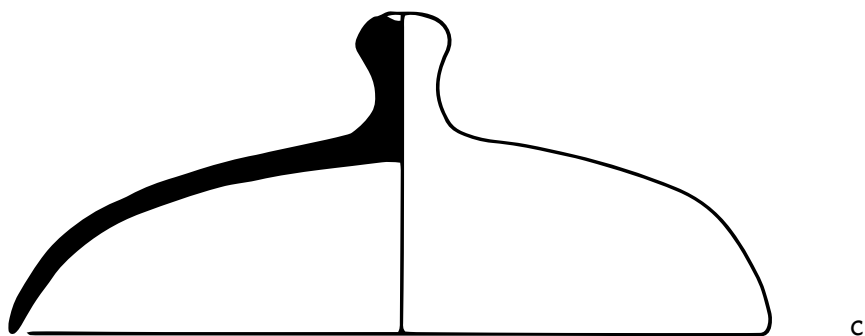
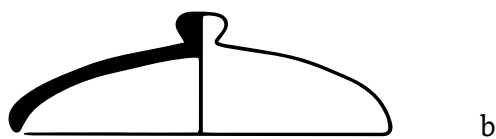
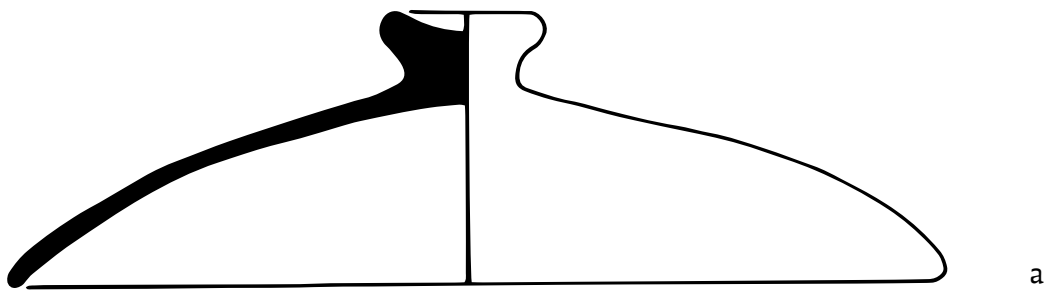

7.1.5 LID

Flat Lid

**Defining characteristics:** A simple, flat or nearly flat lid, often made by rolling out clay rather than by throwing on a wheel.

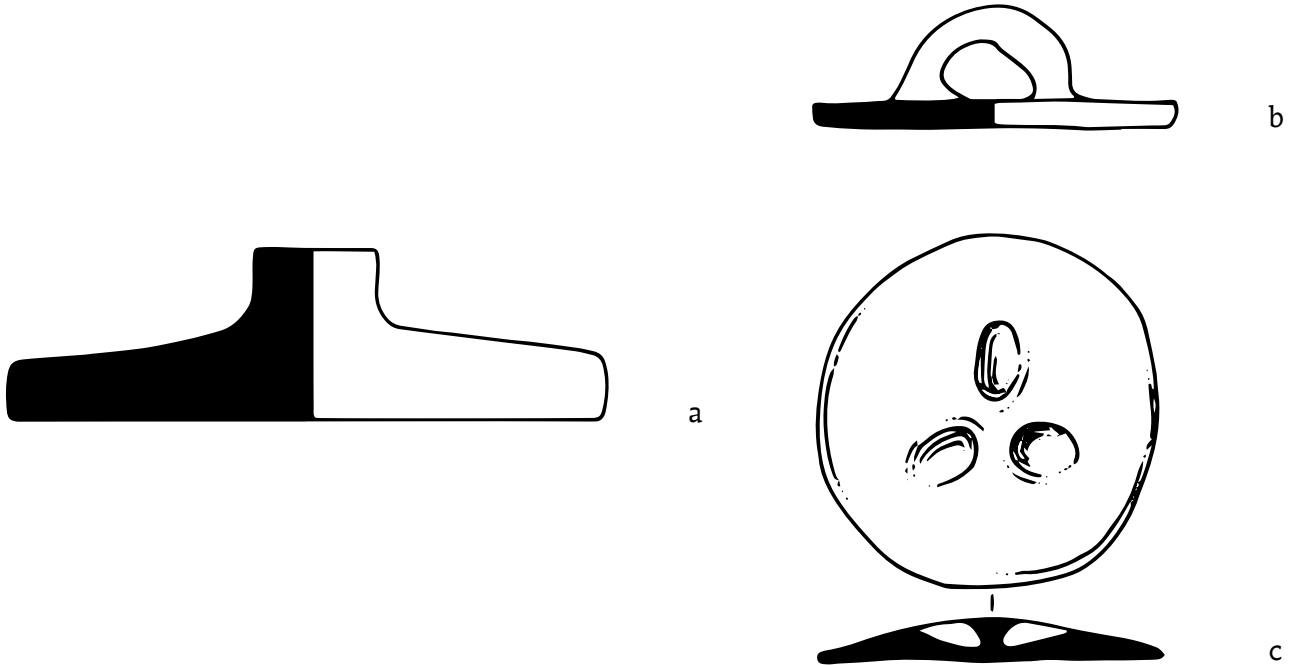

7.1.6 LID

Flat-topped Lid

**Defining characteristics:** A lid resembling an inverted DISH with a flat top and an integral or added knob or loop handle. The profile vary and should be classified in the same way as DISHES (see 5.3).

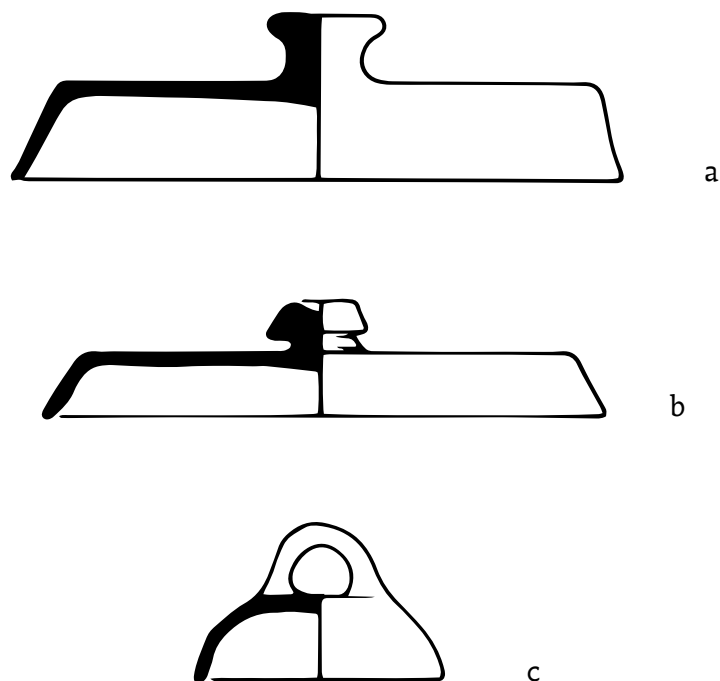

7.1.7 LID

Saucer-shaped Lid

**Defining characteristics:** A lid comprising a shallow flared DISH with an integral *knob* rising from the centre.

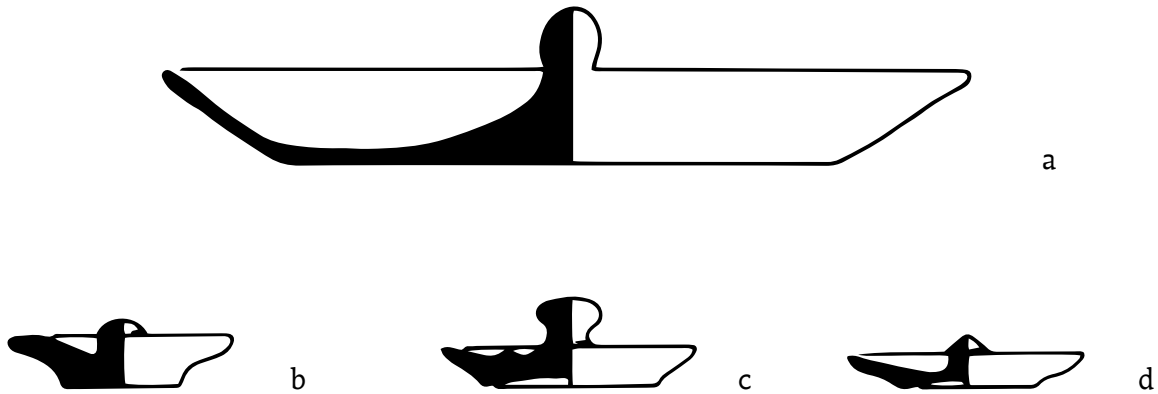

7.1.8 LID

Flanged Lid

**Defining characteristics:** A lid with a distinct flange, projecting upwards, horizontally or downwards, and with an integral *knob*. The most complex examples include a simple locking device, where the lower flange is partly cut away to leave two projections or *lugs*, which can be fitted into corresponding *cut-outs* in the rim of the vessel beneath and secure the lid when it is rotated. These should be termed Locking Lids (see c, below).

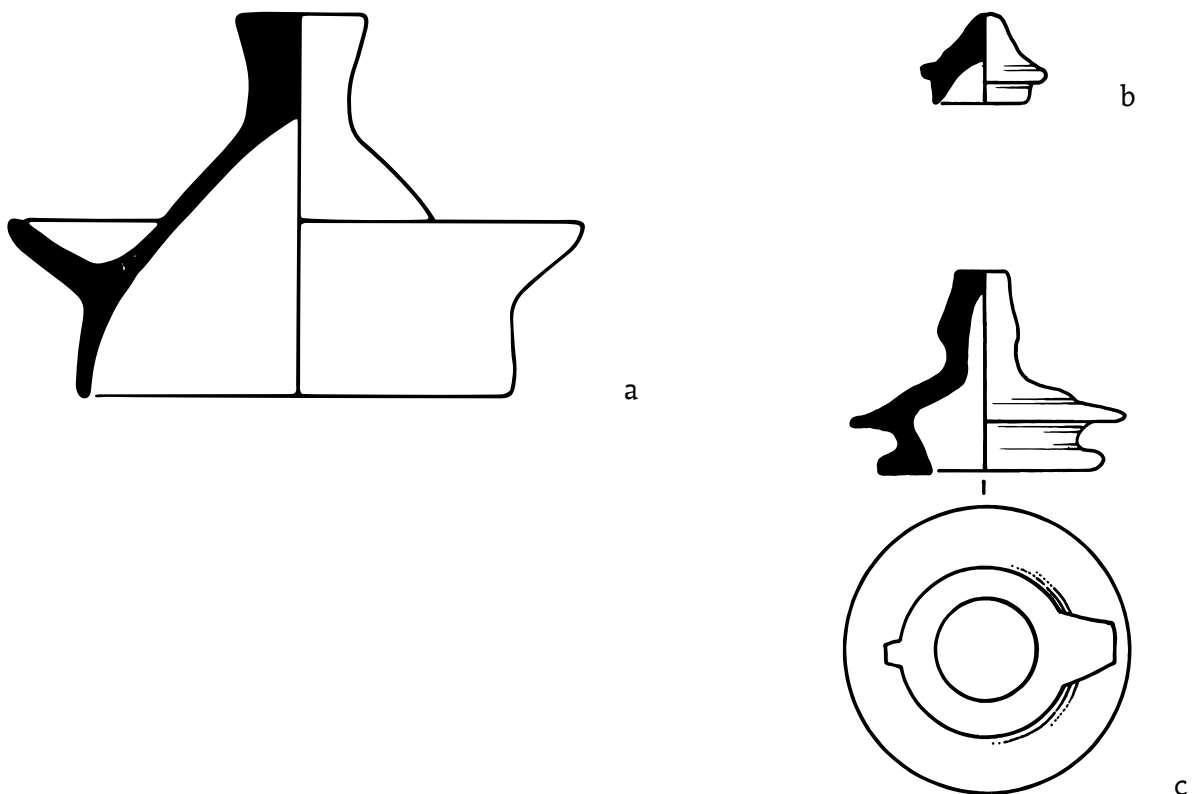

### 7.1.9 LID

### Complex Lid

This category includes complex and/or ornate lids which cannot easily be classified within the above categories. No attempt is made here to describe them individually.

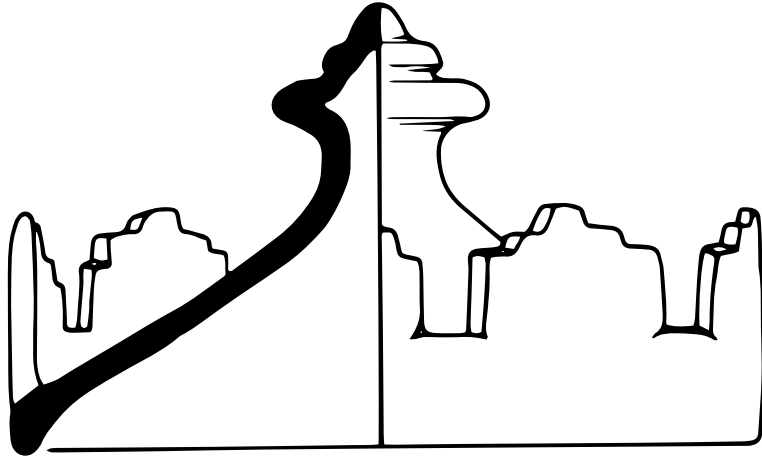

a

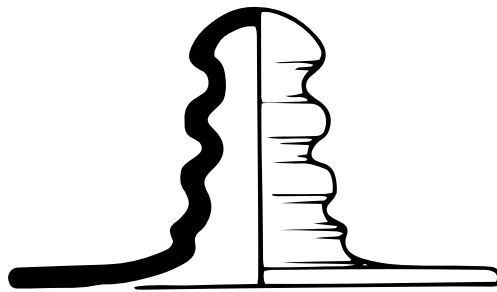

b

## SECTION 8: LIGHTING AND HEATING

---

### Contents

#### Introduction to LIGHTING and HEATING

- 8.1 CANDLESTICK
  - 8.1.1 Saucer Candlestick
  - 8.1.2 Upright Candlestick
  
- 8.2 LAMP
  - 8.2.1 Compartmented Lamp
  - 8.2.2 Double-shelled Lamp
  - 8.2.3 Hemispherical Lamp
  - 8.2.4 Pedestal Lamp
  - 8.2.5 Saucer Lamp
  - 8.2.6 Spike Lamp
  
- 8.3 LANTERN
  
- 8.4 WARMING PAN
  
- 8.5 CURFEW
  - 8.5.1 Flared Curfew
  - 8.5.2 Hemispherical Curfew
  - 8.5.3 Half-round Curfew
  - 8.5.4 Flanged Curfew
  
- 8.6 CHAFING DISH
  
- 8.7 FUMING POT
  
- 8.8 HEATING STAND
  
- 8.9 BEVERAGE WARMER
  
- 8.10 DUTCH OVEN

## Introduction to LIGHTING and HEATING

This section includes vessels which are associated with either lighting or heating. Lighting is considered first, and this covers vessels which are designed to hold either a wick or a candle (CANDLESTICK, LAMP, LANTERN). Next come vessels which are designed to hold coals or embers for general heating/warming purposes (WARMING PAN), or for covering coals or embers on the hearth (CURFEW). Lastly there are the more specialised vessels for burning substances other than fuel (FUMING POT), or for heating or warming food or drink (CHAFING DISH, HEATING STAND, BEVERAGE WARMER, DUTCH OVEN).

### 8.1 CANDLESTICK

**Defining characteristics:** A portable stand with a *socket* to hold a candle. Two basic forms are known:

- 8.1.1 Saucer Candlestick
- 8.1.2 Upright Candlestick

### 8.1 CANDLESTICK

### Candlestick Forms

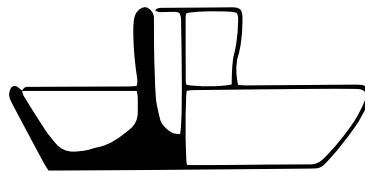

saucer candlestick

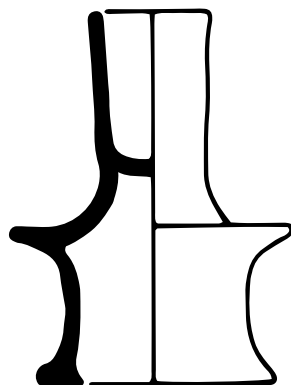

upright candlestick



### 8.1.1 CANDLESTICK

#### Saucer Candlestick

**Defining characteristics:** This consists of a simple *socket* set in the centre of a *drip-tray* or saucer. There may be a vertical *loop handle* linking the socket to the rim of the saucer.

**Alternative names:** Chamber Candlestick, Hand Lamp have been used.

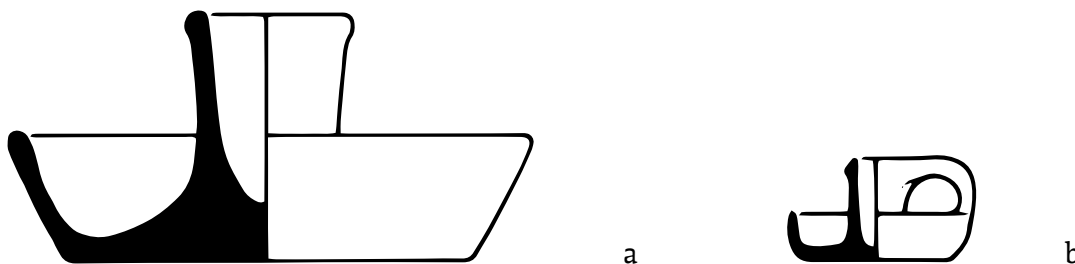

### 8.1.2 CANDLESTICK

#### Upright Candlestick

**Defining characteristics:** In this simple upright form, the *socket* is above a *drip-tray* or grease-tray, on a *pedestal base* which is generally hollow. There may be a vertical *loop handle*. More elaborate forms may possess one or more secondary drip-trays.

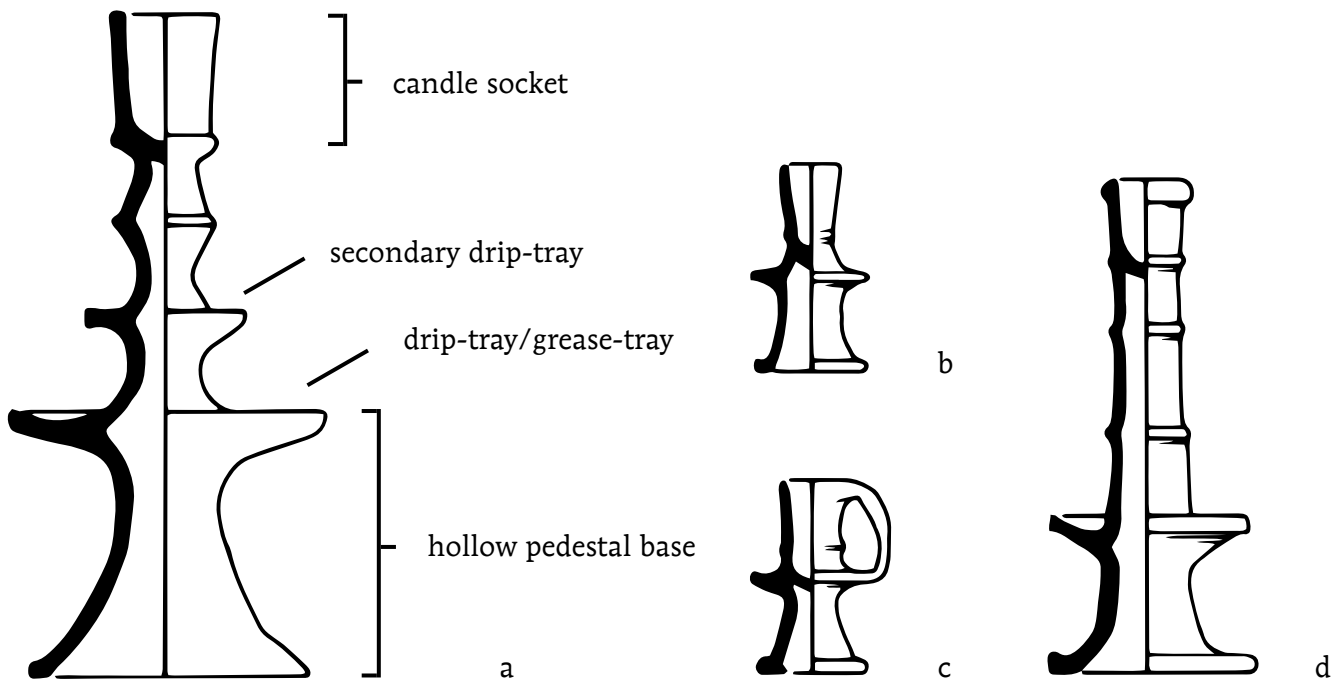

## 8.2 LAMP

**Defining characteristics:** A vessel with a reservoir of some form to hold oil. Several different types of lamp are known, ranging from very simple to complex forms, designed for both free-standing use and for suspension from a wall or ceiling. The main forms are defined as follows:

- 8.2.1 Compartmented Lamp
- 8.2.2 Double-shelled Lamp
- 8.2.3 Hemispherical Lamp
- 8.2.4 Pedestal Lamp
- 8.2.5 Saucer Lamp
- 8.2.6 Spike Lamp

## 8.2 LAMP

## Lamp Forms

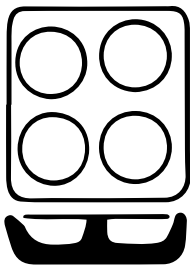

compartmented lamp

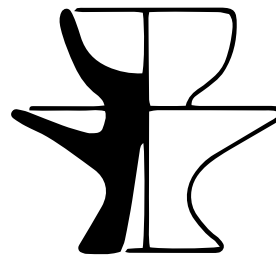

double-shelled lamp

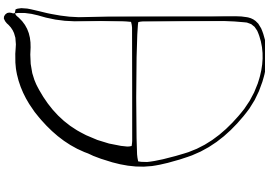

hemispherical lamp

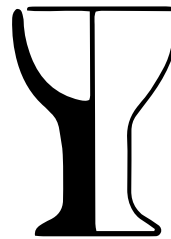

pedestal lamp



saucer lamp

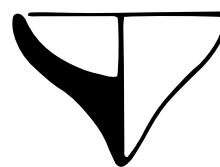

spike lamp

## 8.2.1 LAMP

## Compartmented Lamp

**Defining characteristics:** A deep, square or rectangular, flat slab of clay, the upper surface of which has two or more cup-shaped holders cut into it.

**Bibliography:** Evans 1969.

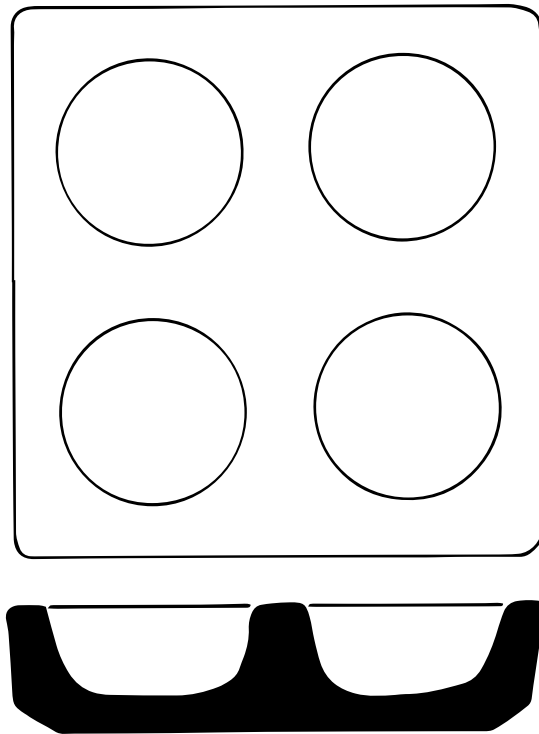

a

## 8.2.2 LAMP

## Double-shelled Lamp

**Defining characteristics:** A PEDESTAL LAMP (see 8.2.4) with a *drip-tray* below the bowl. There may be a vertical *loop handle* linking bowl and drip-tray. Some variants have a more enclosed bowl form with a small *tubular spout* projecting from the bowl (see **b**, below).

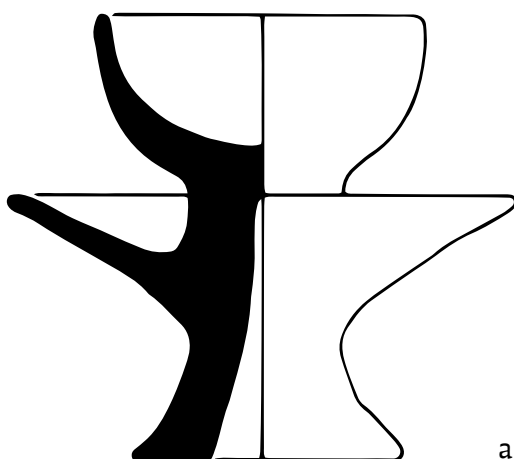

a

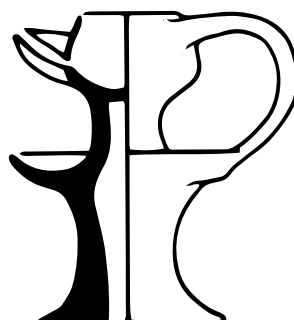

b

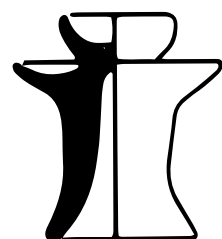

c

### 8.2.3 LAMP

#### Hemispherical Lamp

**Defining characteristics:** A small hemispherical BOWL with a pinched or pulled wick *lip*. This form can also be used as a CRUCIBLE (see 9.6), and it is only evidence of use, for example sooting, that would identify it as a lamp.

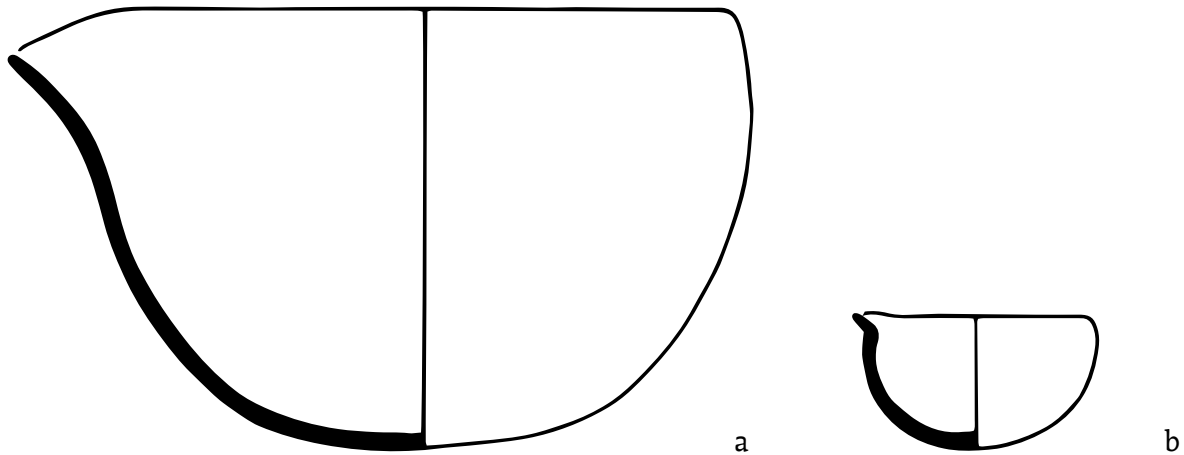

### 8.2.4 LAMP

#### Pedestal Lamp

**Defining characteristics:** A small BOWL on a *pedestal base*, which may be solid or at least partly hollow. It may have a wick *lip* at the rim or a *lug handle* (see e, below).

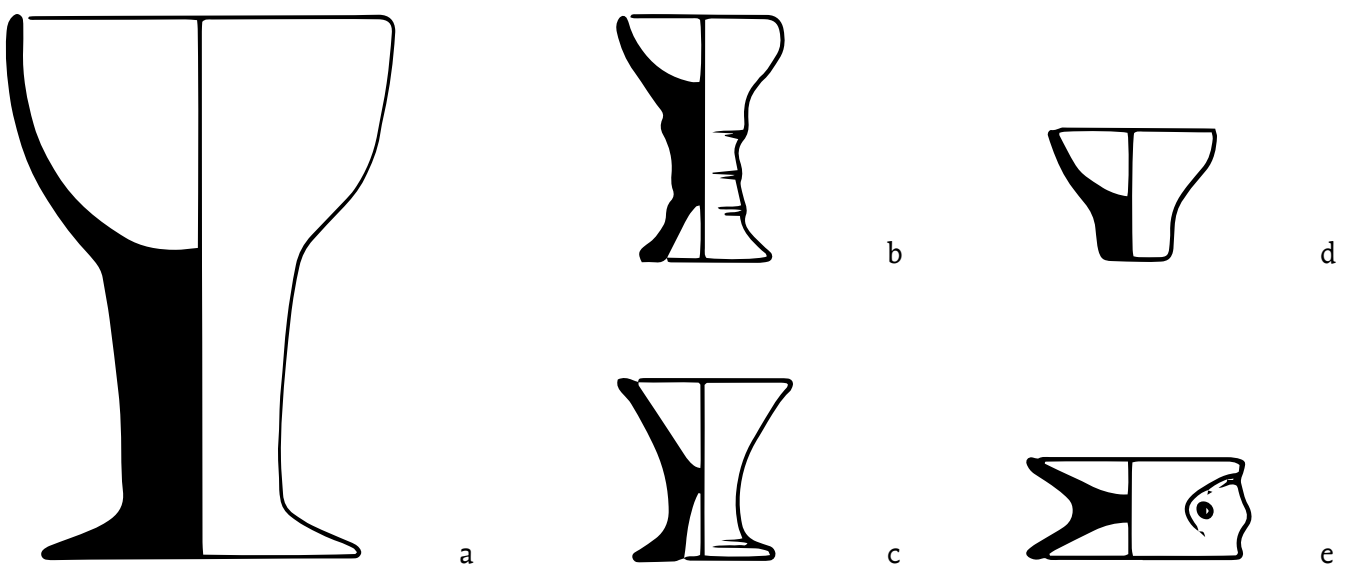

## 8.2.5 LAMP

## Saucer Lamp

**Defining characteristics:** A small BOWL on a *pedestal base* above a *drip-tray* or saucer. It may have a wick *lip* at the rim. There may have one or two *pierced lugs* projecting upwards from the rim for suspension. There may be a *handle* or a *spout* (c), or a vertical *loop handle* linking lamp bowl and saucer.

**Alternative name:** Shelled Lamp has been used.

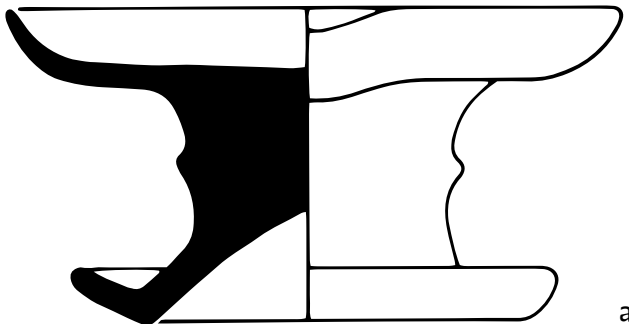

a

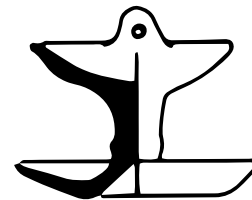

b

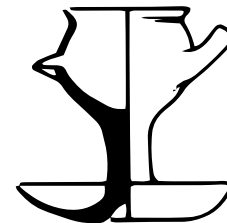

c

## 8.2.6 LAMP

## Spike Lamp

**Defining characteristics:** A small hemispherical or flared BOWL with a solid *pointed base* or spike. It may have a wick *lip* at the rim. There may have one or two *pierced lugs* projecting upwards from the rim, for suspension.

**Alternative names:** Cresset, Pricket Lamp have been used.

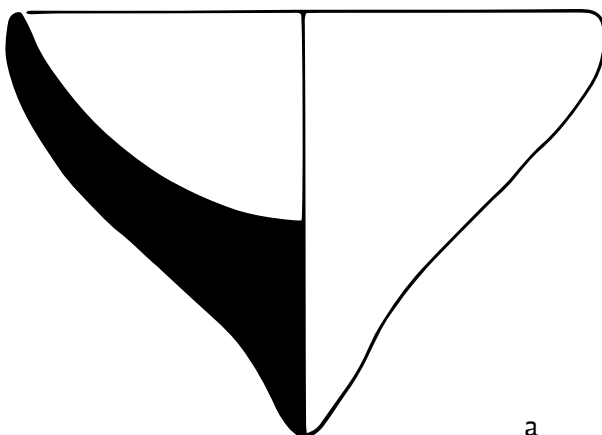

a

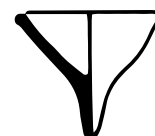

b

### 8.3 LANTERN

**Defining characteristics:** A vessel of closed form with a pierced or perforated body, to hold a candle for lighting. Lanterns may either be made specifically for this function, or may result from the re-use of another vessel.

Ready-made lanterns consist of a nearly cylindrical body with one or more *cut-out(s)* or a 'window' in one side, and inside the base, a tubular *socket* or candle-holder. There may be a *loop handle* on the side opposite the cut-out. This is a rare ceramic form, copying a metal lantern.

**Bibliography:** Verhaeghe 1992.

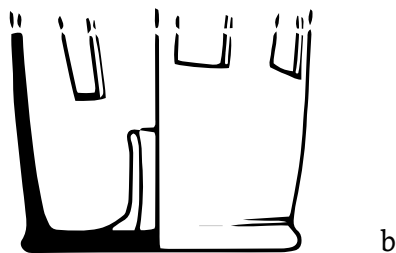
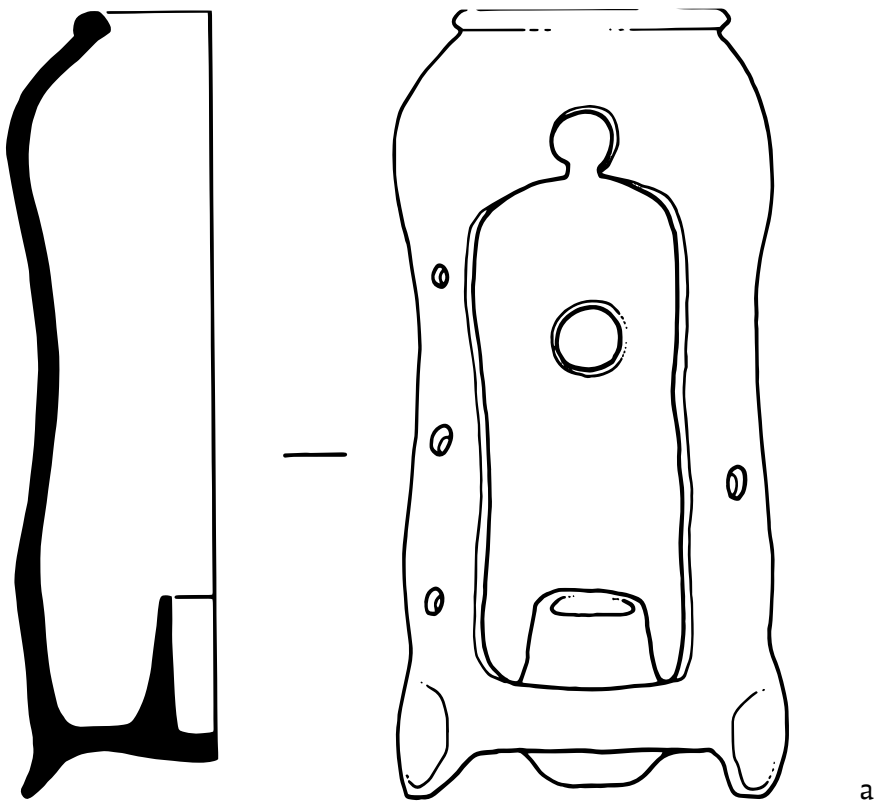

## 8.4 WARMING PAN

**Defining characteristics:** A vessel of closed form, generally fairly squat, with a narrow neck, multiple holes pierced through the body, and one long *straight*, often *tubular*, *handle*.

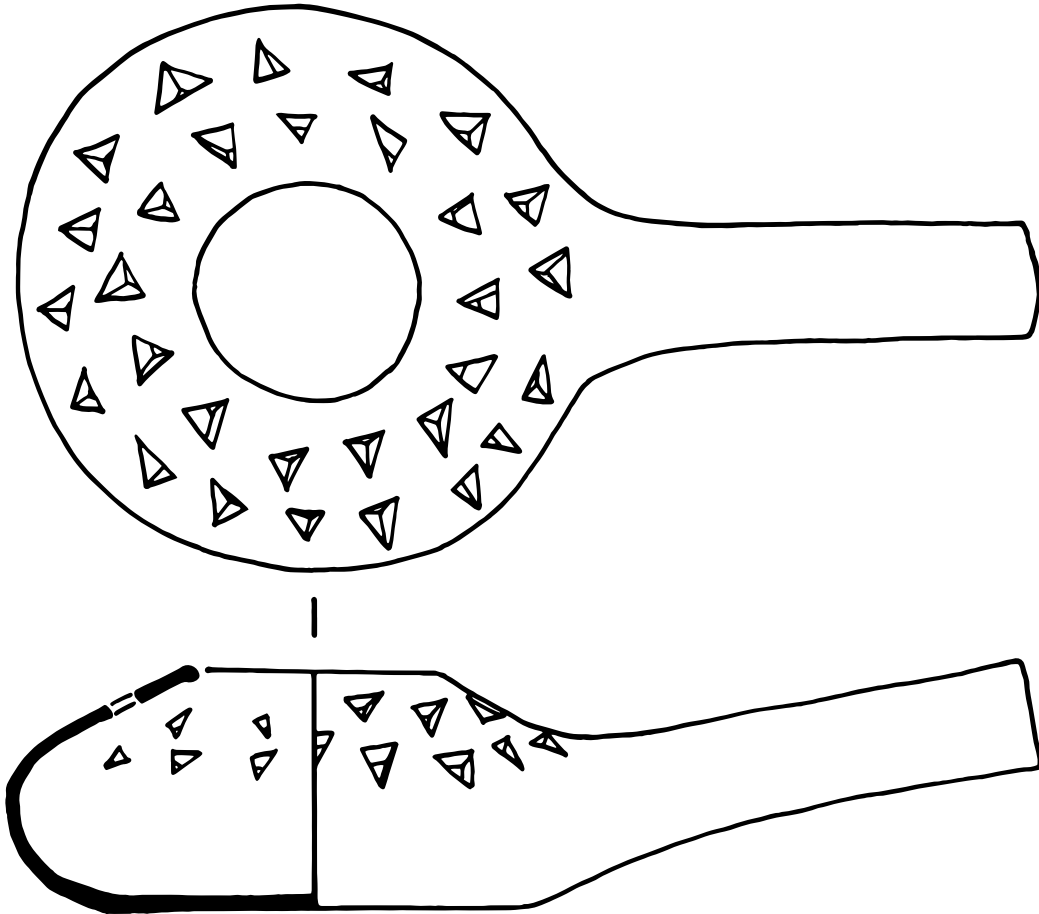

a

## 8.5 CURFEW

**Defining characteristics:** Curfews are open vessels with the opening and maximum diameter at the bottom. In their simplest form they consist of inverted BOWLS with a *loop handle* added to the top and with one or more holes in the top and/or walls. Where the handle and/or pierced holes do not survive, these vessels may be difficult to distinguish from BOWLS, although the function may be revealed by the presence of internal sooting, particularly if heavy, inside the top or 'base'. These vessels are usually large.

### 8.5 CURFEW

### Curfew Forms

Profiles are classified in the same way as BOWLS (see 5.1.1-5.1.7).

The most common profiles are:

- 8.5.1 Flared Curfew
- 8.5.2 Hemispherical Curfew

**Variations:** The *loop handle* may be placed at the 'base' (top) angle rather than centrally. Some examples have two handles flanking a central aperture; others have opposed *lug handles* on the sides. More elaborate examples may have a raised *knob* flanked by opposed vertical loop handles. Rare examples have a number of hooded *vents*.

Later in the medieval period, the increasing use of fireplaces below side chimneys, rather than a central hearth, is reflected in the shape of curfews. They are adapted for use against walls by halving the basic BOWL form:

- 8.5.3 Half-round Curfew
- 8.5.4 Flanged Curfew

**Alternative name:** Fire Cover has been used.



## 8.5 CURFEW

## Curfew Forms

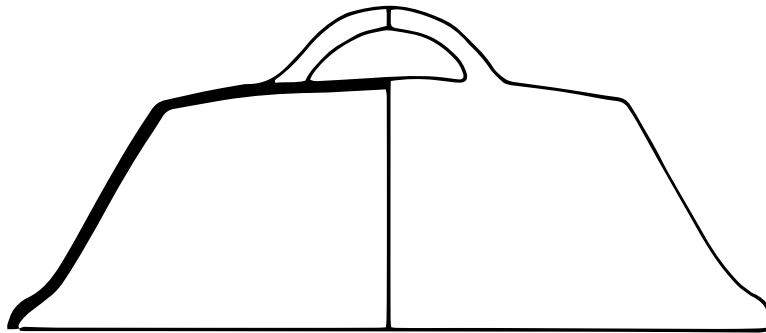

flared curfew

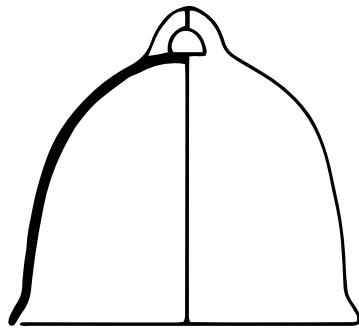

hemispherical curfew

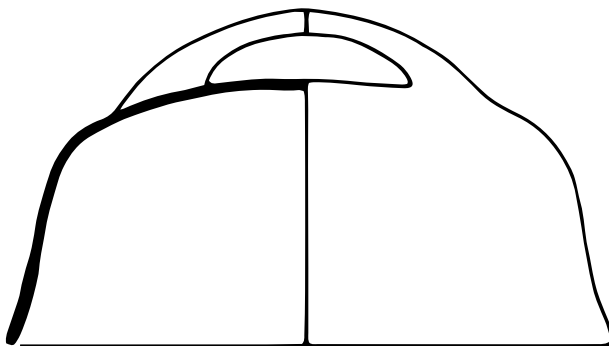
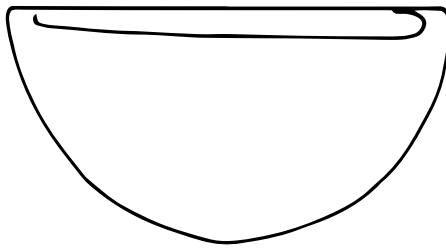

half-round curfew

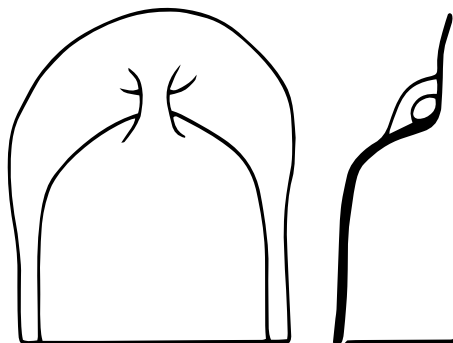

flanged curfew

### 8.5.1 CURFEW

### Flared Curfew

**Defining characteristics:** A curfew with straight sides flaring outwards from the top.

**Alternative name:** Bowl Curfew has been used.

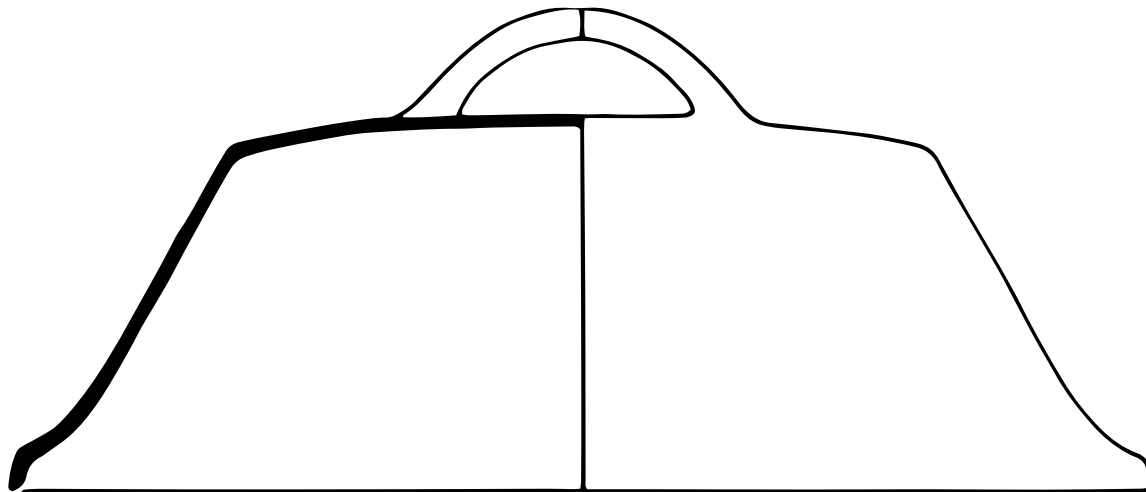

a

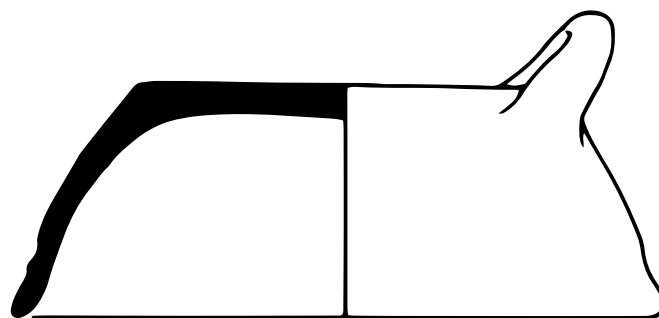

b

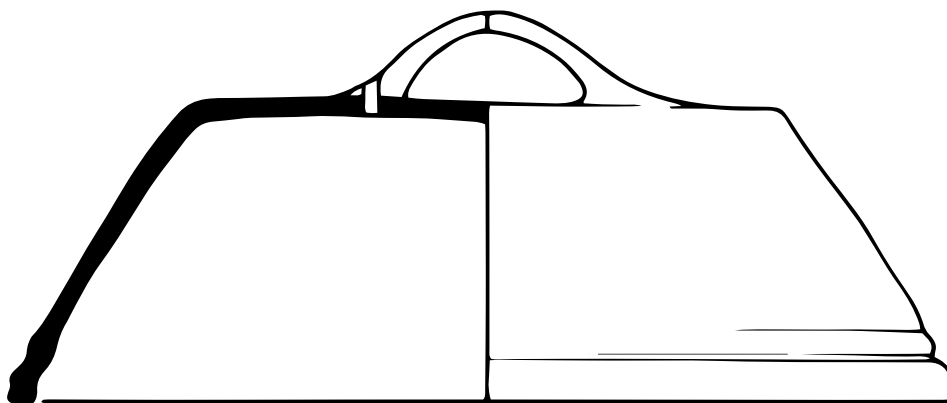

c

### 8.5.2 CURFEW

#### Hemispherical Curfew

**Defining characteristics:** A curfew with a rounded profile merging into a rounded top, with no discernible angle.

**Alternative name:** Bell-shaped Curfew has been used.

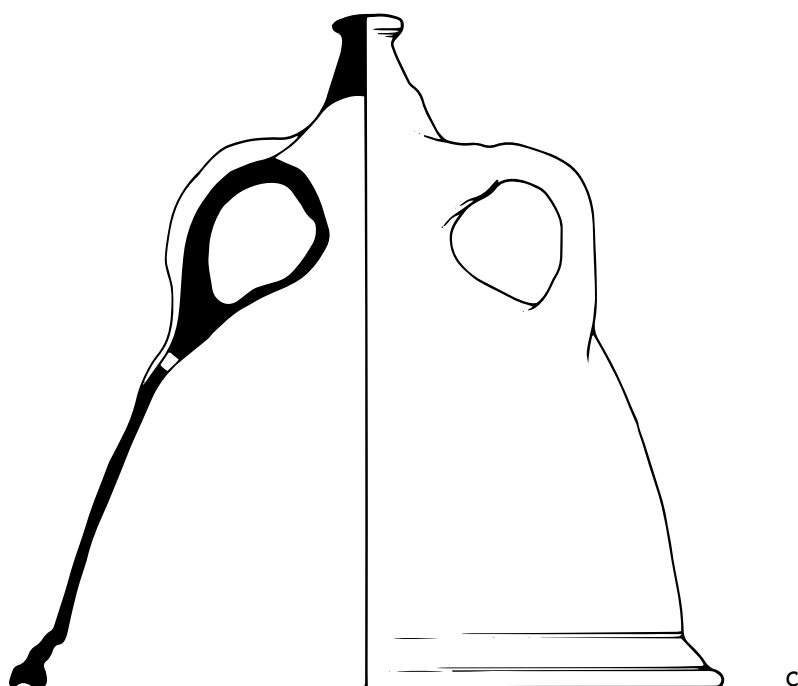
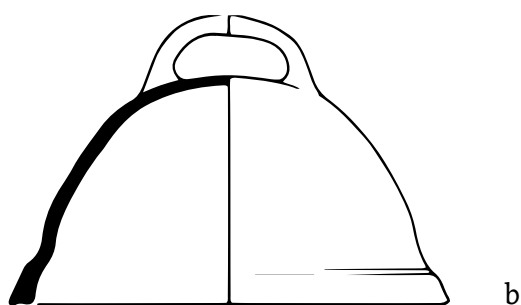
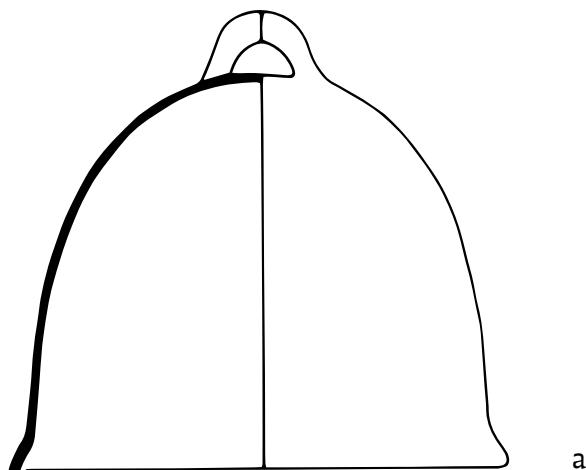

### 8.5.3 CURFEW

#### Half-round Curfew

**Defining characteristics:** A curfew consisting of a half-section of an inverted BOWL. The form is adapted for use against a wall. They should be classified by profile in the same way as full bowl curfews (see 8.5.1-8.5.2).

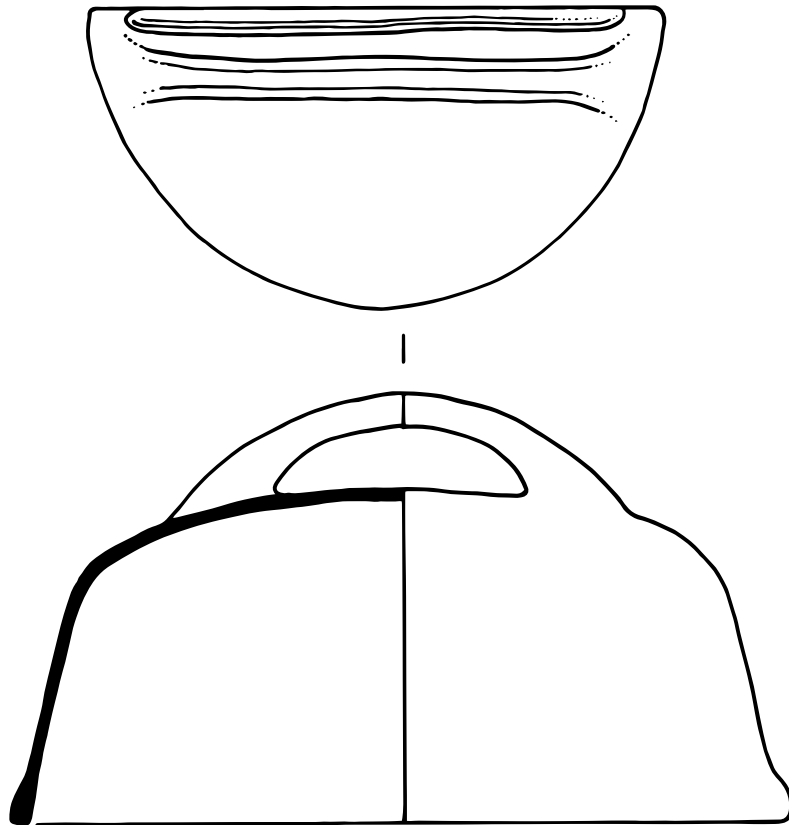

a

### 8.5.4 CURFEW

#### Flanged Curfew

**Defining characteristics:** A curfew consisting of a half-bell shape with a raised flange around the cut-away side. A vertical *loop handle* joins the flange and body. The form is adapted for use against a wall. Some are highly decorated.

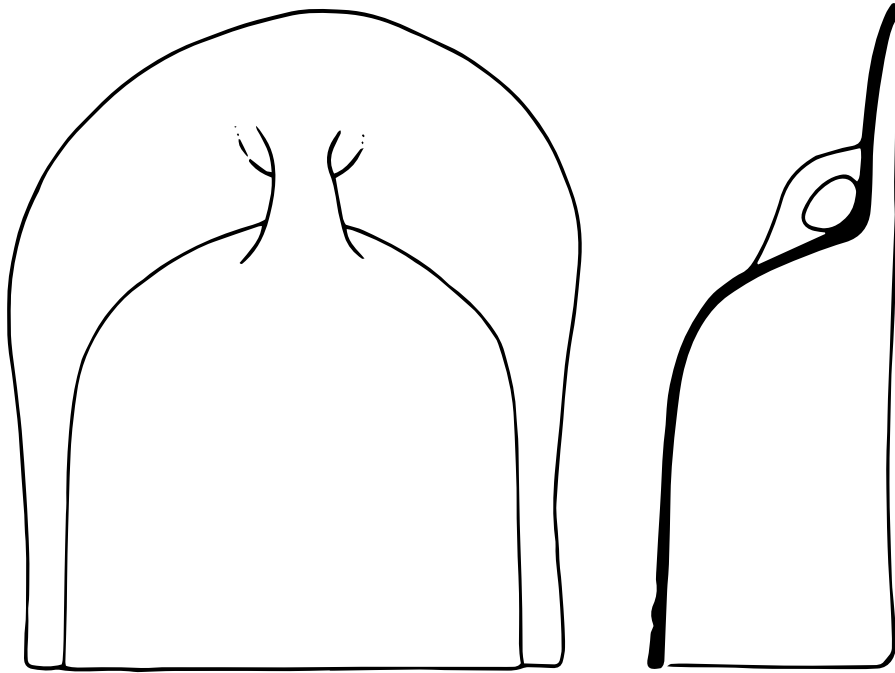

a

## 8.6 CHAFING DISH

**Defining characteristics:** A BOWL or DISH surmounting an open or closed hollow *pedestal base*, with equally spaced vertical *rim supports* (of various shapes) projecting upwards from the rim. There may be one or more *handles* on the sides of the bowl. Profiles vary, and should be classified in the same way as BOWLS (see 5.1.1-5.1.7).

The *rim supports* may be in the form of *crenellation* (a regular cutting away) of the rim. Examples are known with a tripod base as an alternative to the pedestal base.

The *pedestal base* may have in the side one or more *vents* or *cut-outs* of varying shapes and sizes to encourage air flow. The sides and/or base of the bowl may also be pierced with vents of various shapes.

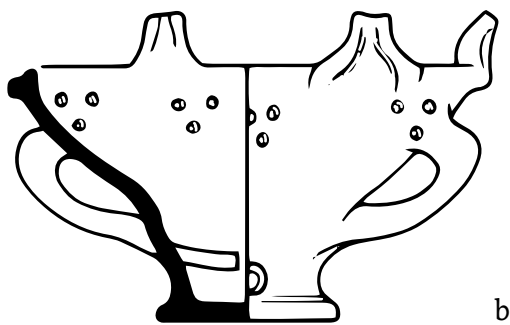
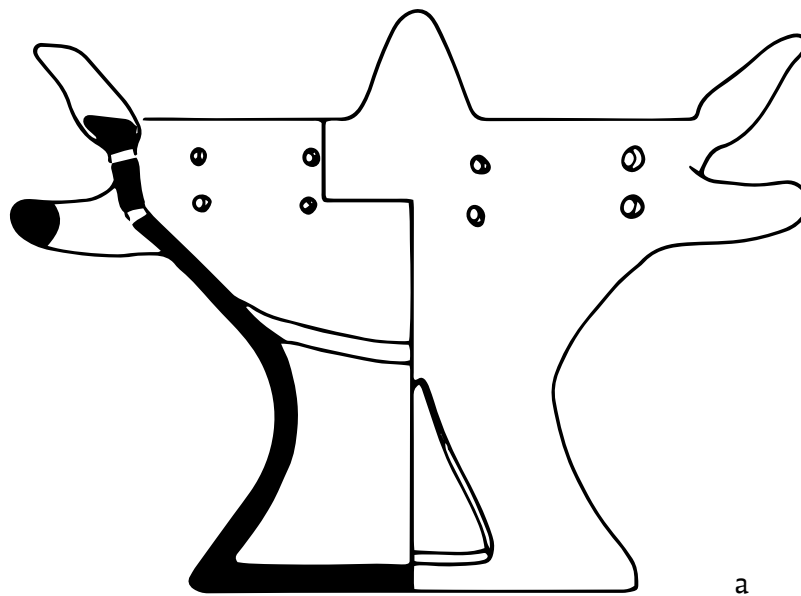

b

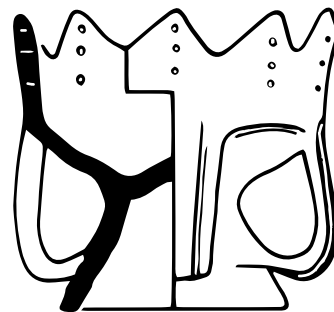

d

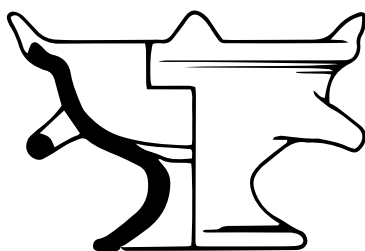

c

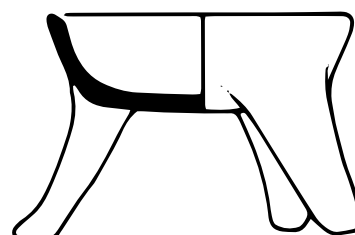

e

## 8.7 FUMING POT

**Defining characteristics:** A jar-shaped vessel with pierced apertures or *cut-outs* of varying shapes and sizes, on an open or closed *pedestal base*. There may be one or more *handles*.

**Alternative name:** Fire Pot has been used.

**Bibliography:** Platt and Coleman Smith 1975, 113, fig. 168, no. 766.

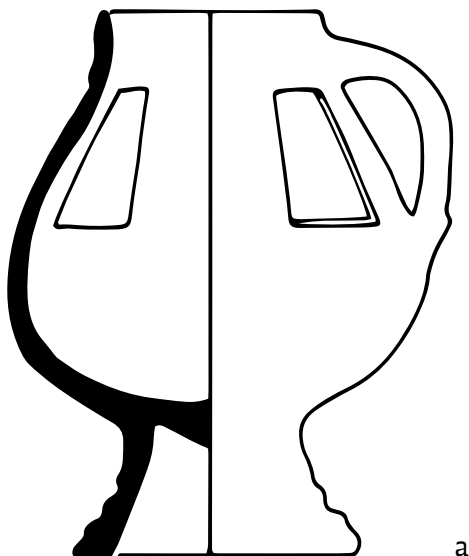

## 8.8 HEATING STAND

**Defining characteristics:** A narrow-necked form with pierced apertures or *cut-outs* of varying shapes and sizes, on an open or closed *pedestal base*. The profile may be quite angular with carinations above the base and at the shoulder. The body may be separated from the pedestal, and this base may also be pierced. The pedestal may have a *vent* or *cut-out*. There may be opposed *handles*.

Some examples may have been for use in conjunction with BEVERAGE WARMERS (see 8.9).

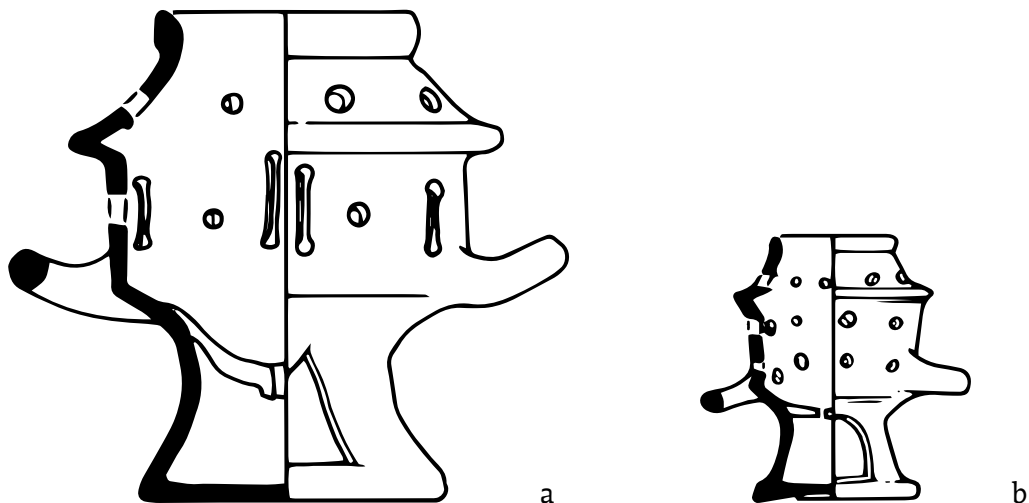

## 8.9 BEVERAGE WARMER

**Defining characteristics:** A small, handled, open vessel, generally with a stepped profile, designed to sit partially within a larger vessel. There is one *horizontal handle* attached below the *rim* which may be *lid seated*.

The form may have been used in conjunction with a HEATING STAND (see 8.8).

**Alternative name:** Later examples may be part of what is known by the French term *veilleuse*.

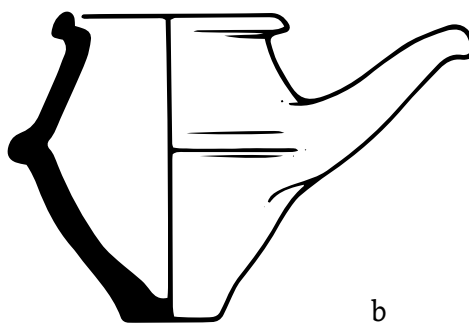
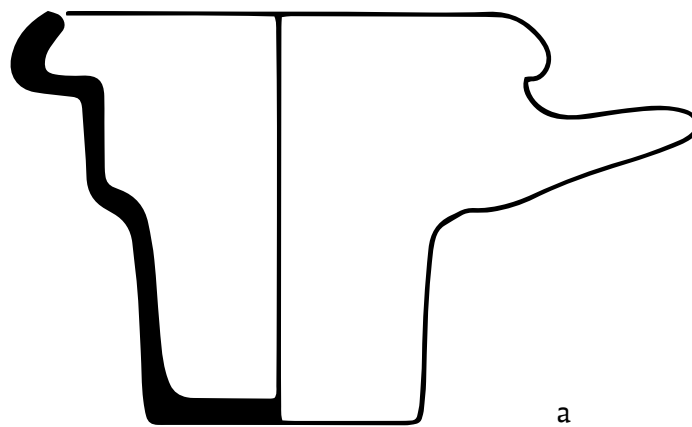



## 8.10 DUTCH OVEN

**Defining characteristics:** A semi-circular or rectangular vessel with an L-shaped profile, applied *feet* and one or two *handles* attached to the back of the vessel. It may be two-tiered, having an upper shelf (see c, below) and may have *feet* on both sides.

**Alternative names:** Apple Roaster, Bacon Roaster and Chestnut Roaster have been used.

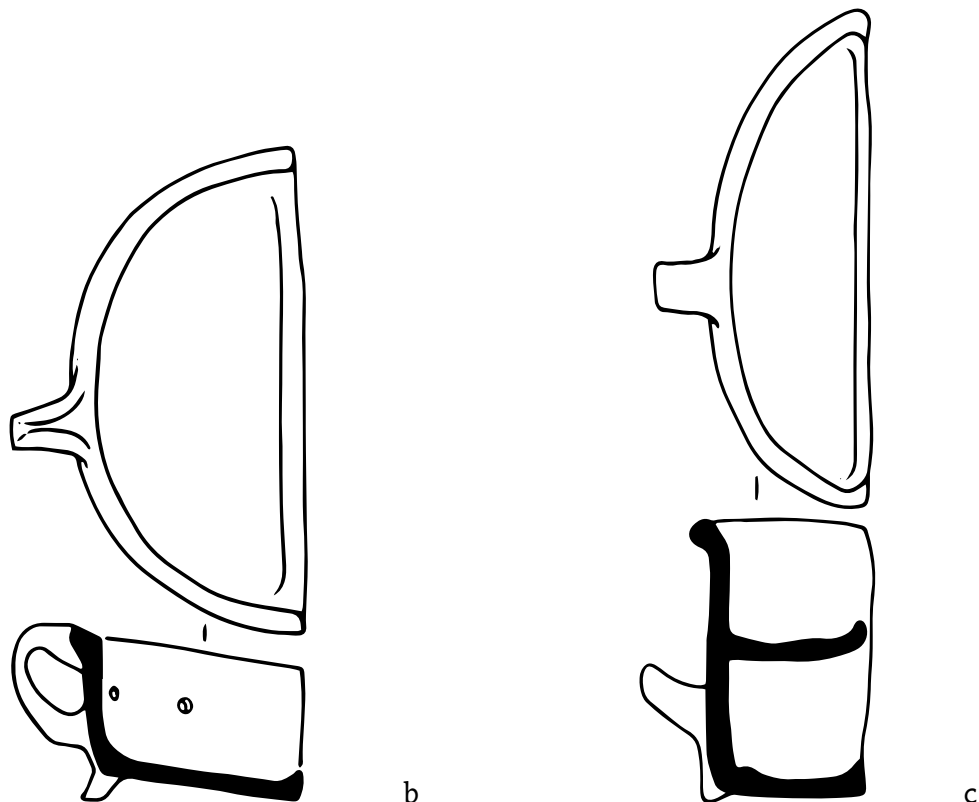
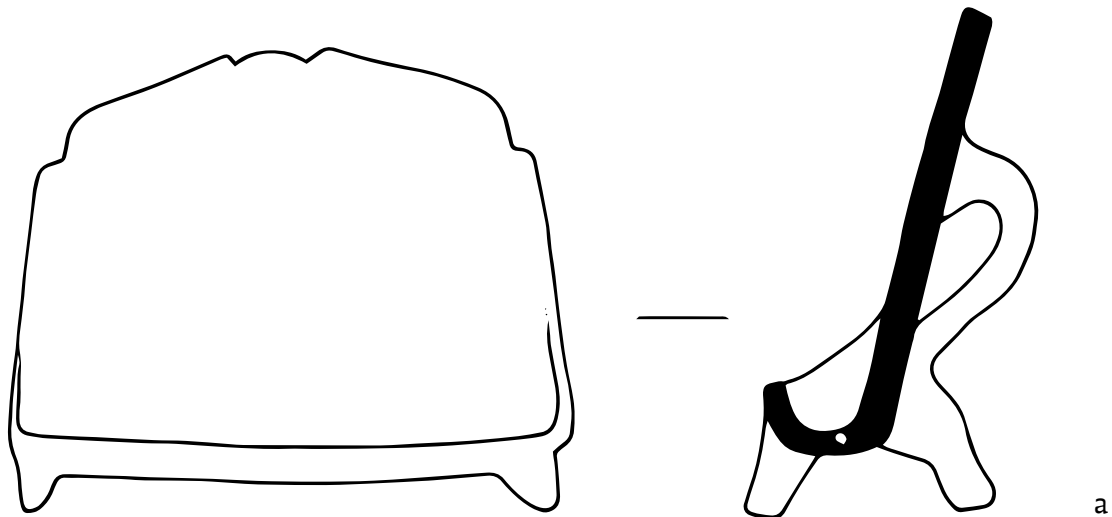

## SECTION 9: INDUSTRIAL VESSELS

---

### Contents

#### Introduction to INDUSTRIAL VESSELS

- 9.1 ALEMBIC
- 9.2 ALUDEL
- 9.3 CUCURBIT
- 9.4 INDUSTRIAL BASE
- 9.5 MANTLE
- 9.6 CRUCIBLE
- 9.7 CUPEL
- 9.8 PARTING VESSEL
- 9.9 CANDLEMAKER'S TROUGH
- 9.10 SUGAR CONE MOULD
- 9.11 SYRUP-COLLECTING JAR

#### Introduction to INDUSTRIAL VESSELS

This section covers vessels used in a variety of industrial processes, for example metalworking, distilling and sugar-refining. It does not include objects such as moulds, items of kiln furniture or any other structural elements such as hearths or furnaces.

Most of these forms are highly specialised, purpose-made vessels and some, particularly those used in the distilling process, copy glass vessels. In other cases forms are not so distinctive; hemispherical CRUCIBLES could be mistaken for LAMPS of a similar form; the SYRUP-COLLECTING JARS used in the sugar-refining process are plain, functional forms which on their own would not obviously be associated with an industrial process, and could be classified in the same way as JARS (see 4.1). It should be noted that ordinary domestic vessels can also be used in industrial processes.

A simplified illustration of a **Distillation Unit** (see below) shows the names of the main components.

**Bibliography:** A good introduction to the use of pottery vessels in industrial processes is given by Moorhouse (1972); metalworking ceramics are summarised by Bayley (1992), and the sugar-refining industry is described by Brooks (1983).

## A Simplified Illustration of a Distillation Unit

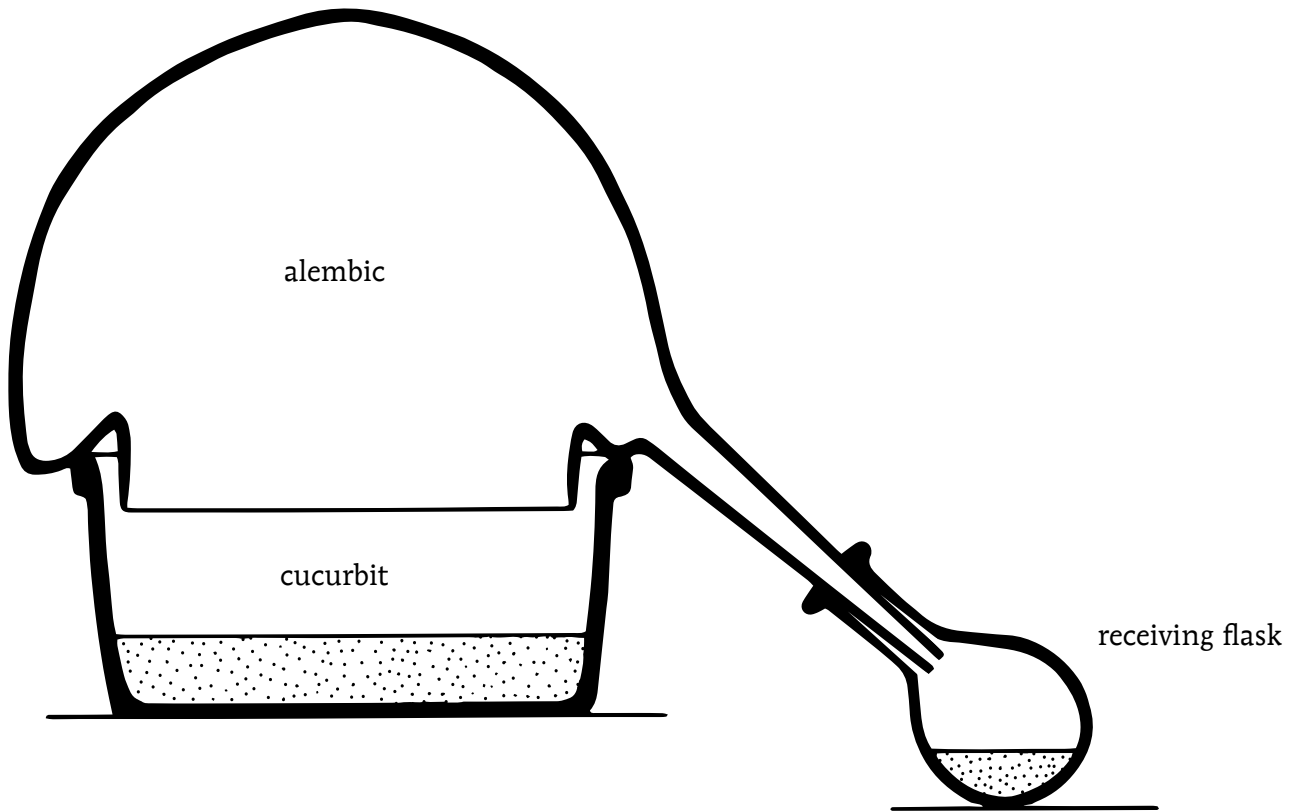

## 9.1 ALEMBIC

**Defining characteristics:** The upper part of a Distillation Unit, comprising a domed vessel with an *inturned rim* forming a channel or collecting area, and a *tubular spout* running downwards from the channel. The shape of this form can vary enormously, so vessels are best described individually.

Variants for use one on top of the other (Stacking Alembics) have a hole, or are open, at the top.

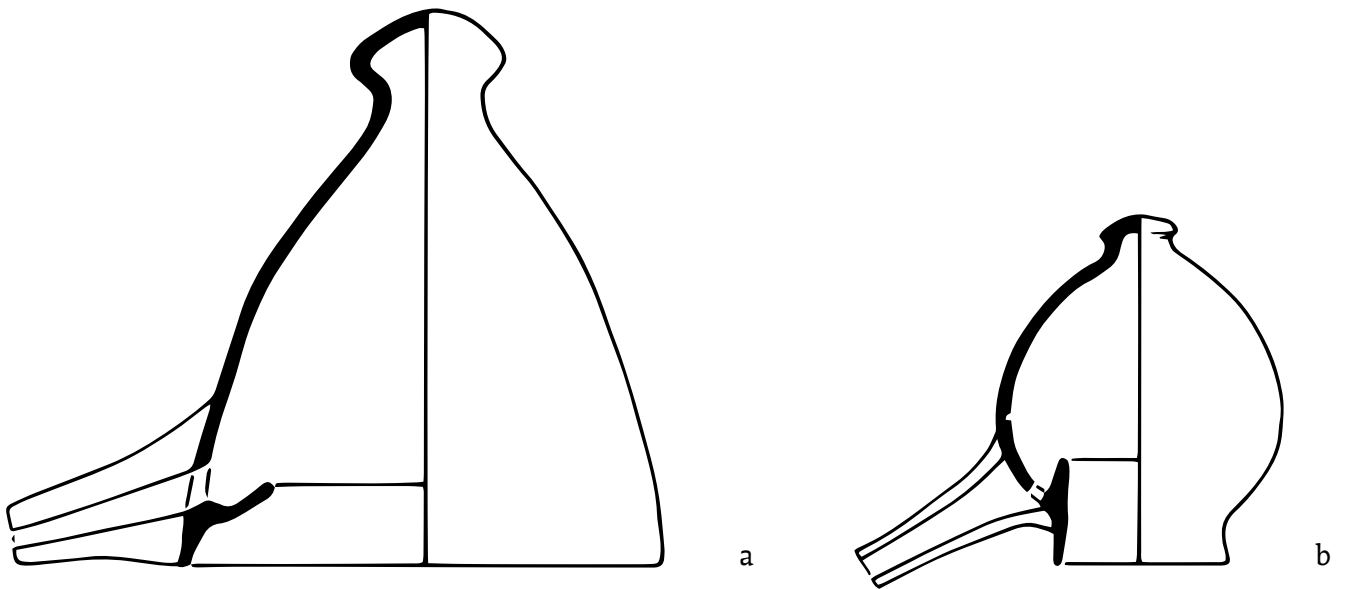

## 9.2 ALUDEL

**Defining characteristics:** A vessel used between a CUCURBIT and an ALEMBIC as part of a Distillation Unit. A conical vessel with a wide, open base and a narrow, open top. The profile can vary, with the most common form having nearly straight or slightly rounded sloping walls.

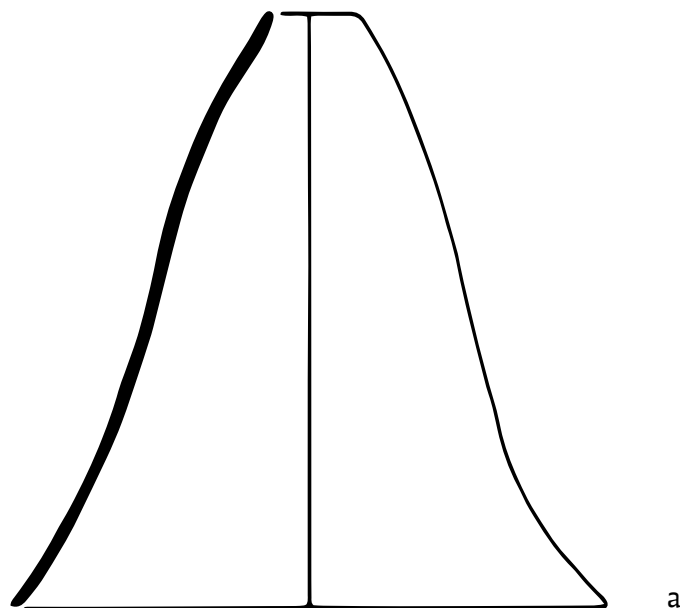

### 9.3 CUCURBIT

**Defining characteristics:** The lower part of a Distillation Unit, used in conjunction with an ALEMBIC, consisting of a round-bottomed vessel with walls sloping inwards towards the rim. Some examples may have an external *flange* to support the upper unit (ALEMBIC).

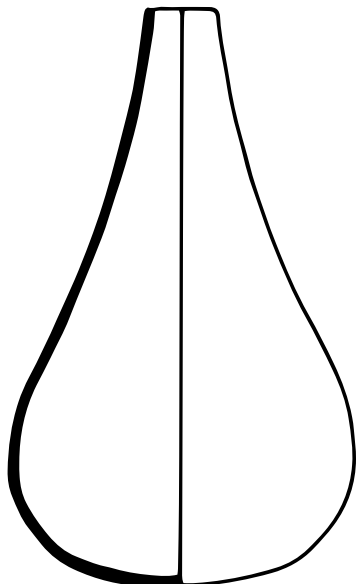

a

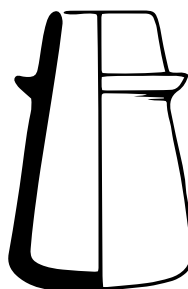

b

### 9.4 INDUSTRIAL BASE

**Defining characteristics:** The lower part of a Distillation Unit, usually with a rounded or inward-sloping profile. The rim has an external or internal seating *flange* to support the upper unit (ALEMBIC), and may have a simple *cut-out* to accommodate the alembic *spout*.

**Alternative name:** Distilling Base has been used.

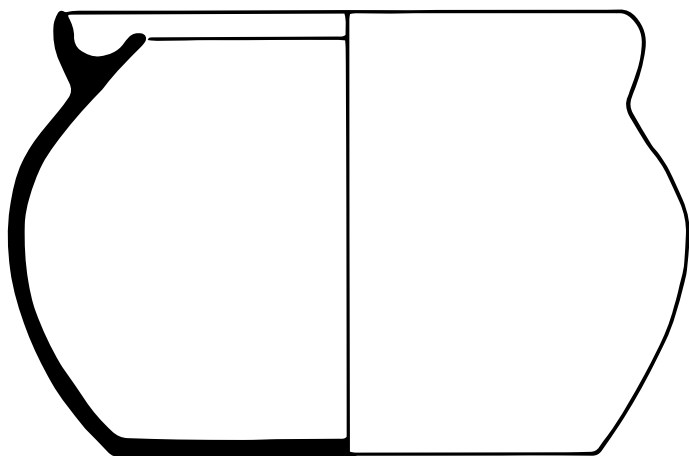

a

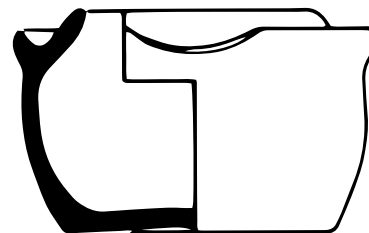

b

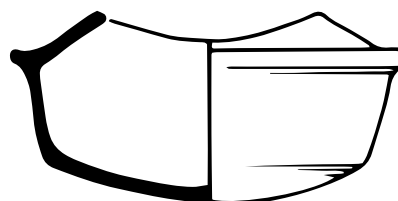

c

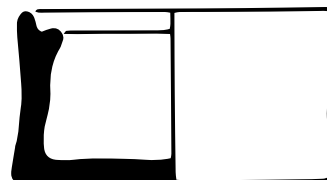

d

## 9.5 MANTLE

**Defining characteristics:** An open-topped vessel used to hold an INDUSTRIAL BASE, consisting of a straight-sided, open vessel, with a vertical slot or *cut-out* to accommodate the *spout* of the ALEMBIC. The vessel wall is pierced by multiple *vents*.

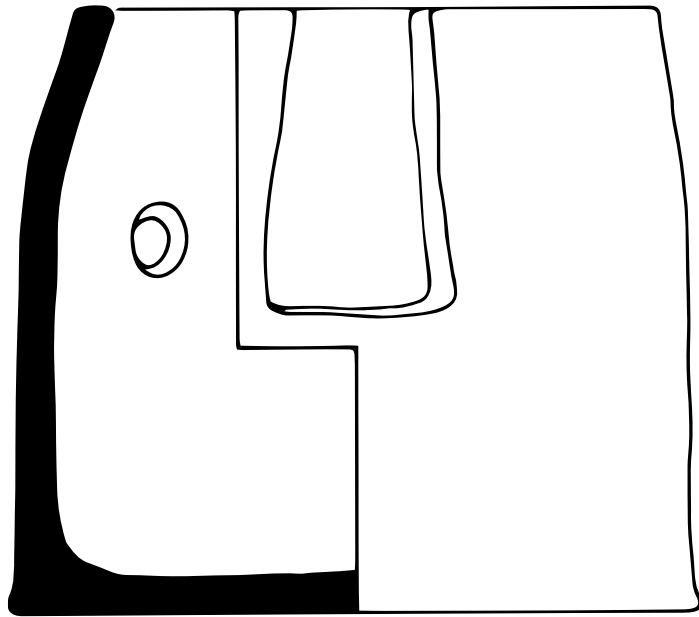

a

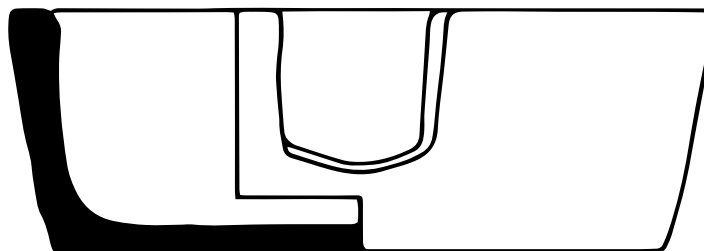

b

## 9.6 CRUCIBLE

**Defining characteristics:** A vessel for heating and melting metals, generally globular or rounded in shape, with a *rounded* or slightly *pointed base*, a *simple rim* and usually, a *lip*. One of the most common crucible forms (a) was also used as a LAMP (see 8.2.3). It is only evidence of use that identifies them as crucibles.

Particularly small crucibles (Thumb Crucibles) were used for working with precious metals (c, below). More open forms may be termed Dish Crucibles (d, below), while deeper, straight-sided crucibles are a later medieval variant (e, below). Triangular forms of mainly post-medieval date are also known; these are rounded, beaker-like vessels with the sides folded inwards to create a triangular mouth (f and g, below; Cotter 1992).

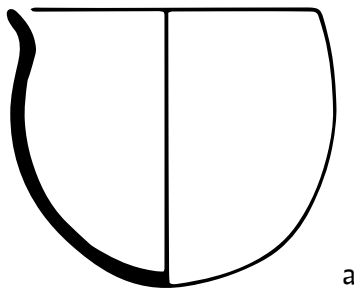

a

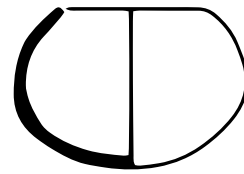

b



c



d

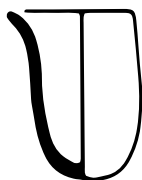

e



f



g

### 9.7 CUPEL

**Defining characteristics:** A small shallow DISH, purpose-made for metal refining. Generally thick-walled, with a crude appearance.

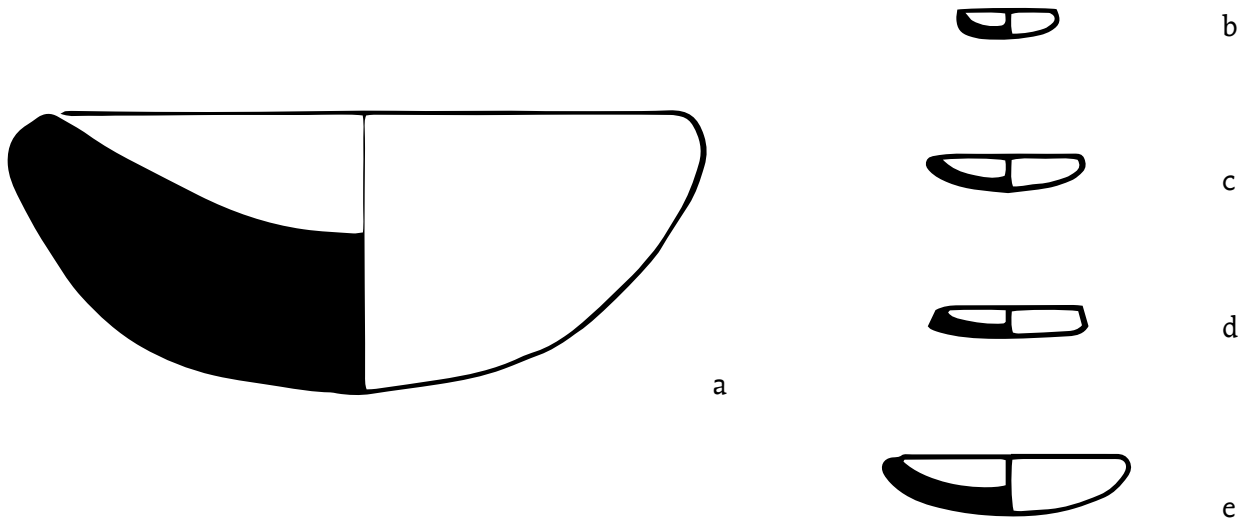

### 9.8 PARTING VESSEL

**Defining characteristics:** A square or rectangular vessel used in metal processing, with straight upright sides and a pointed rim. The vessel would have been used in conjunction with a LID.

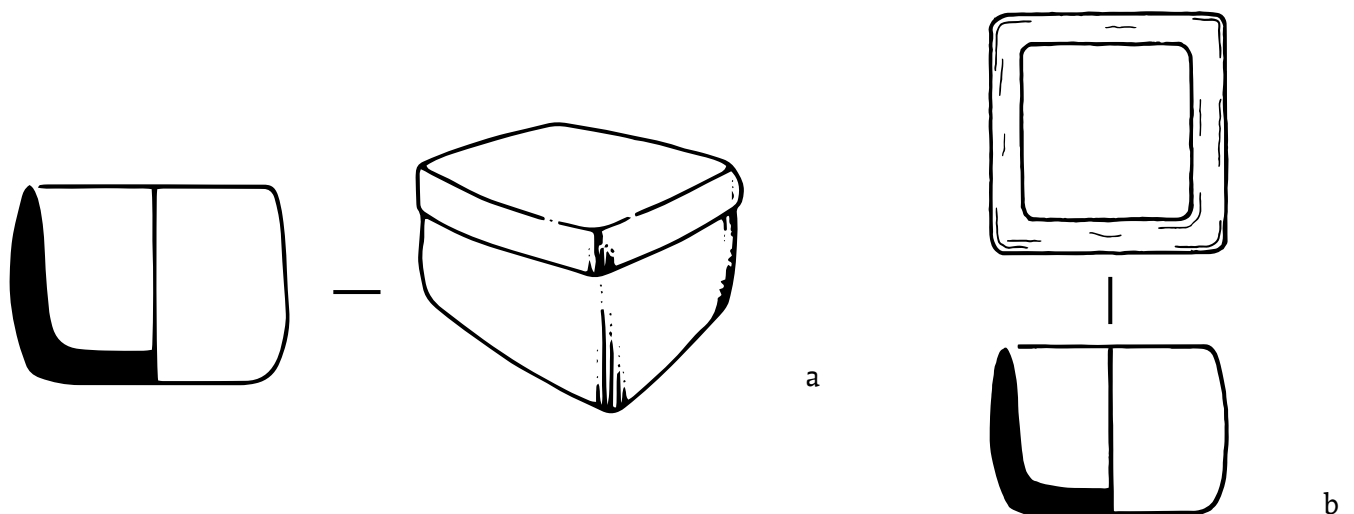



## 9.9 CANDLEMAKER'S TROUGH

**Defining characteristics:** A deep, rectangular or oval, straight-sided vessel with an everted, *crenellated rim*, used to hold either wax for dipping candles, or molten sulphur for dipping matches. The vessel would probably have been used with a LID.

All examples known are Continental (see Hurst *et al.* 1986, 140, fig. 65, no. 223, pl. 22).

**Alternative name:** Box has been used.

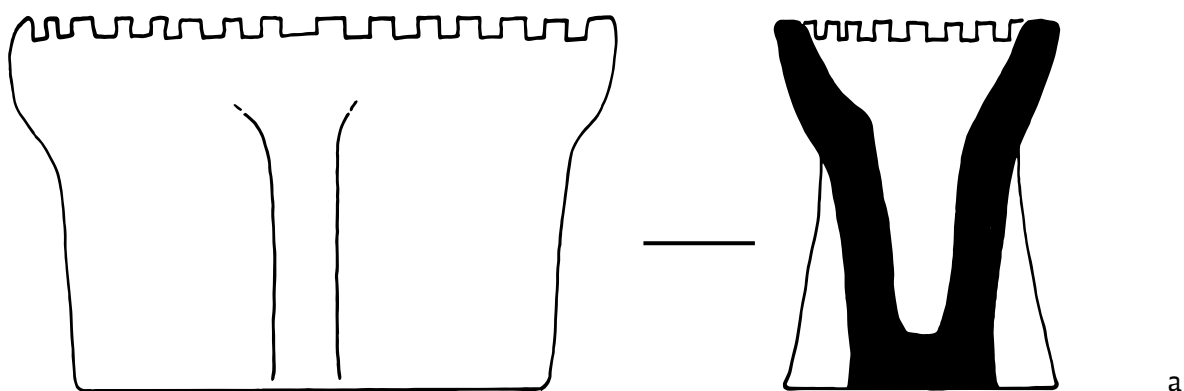

## 9.10 SUGAR CONE MOULD

**Defining characteristics:** A large, straight-sided, conical vessel, open at the top and bottom, used as a mould for sugar-loaves, made in a range of sizes, and used in conjunction with a SYRUP-COLLECTING JAR (see 9.11).

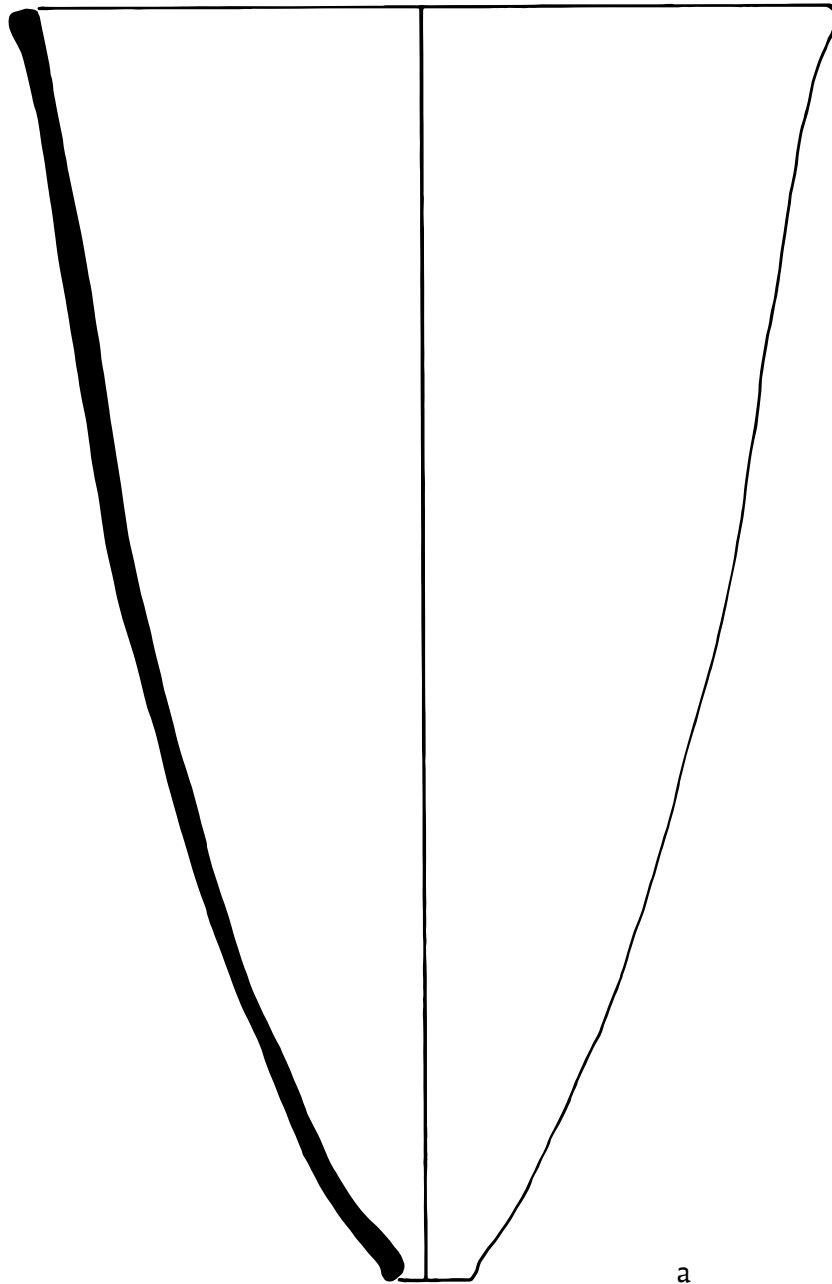

a

## 9.11 SYRUP-COLLECTING JAR

**Defining characteristics:** A large, high-shouldered JAR with heavy rim and thick base, used during the sugar-refining process in conjunction with a SUGAR CONE MOULD (see 9.10), to collect the molasses which drained out of the opening at the mould base.

Some examples have a *footring* or a *rounded base* with three *feet* (see b, below).

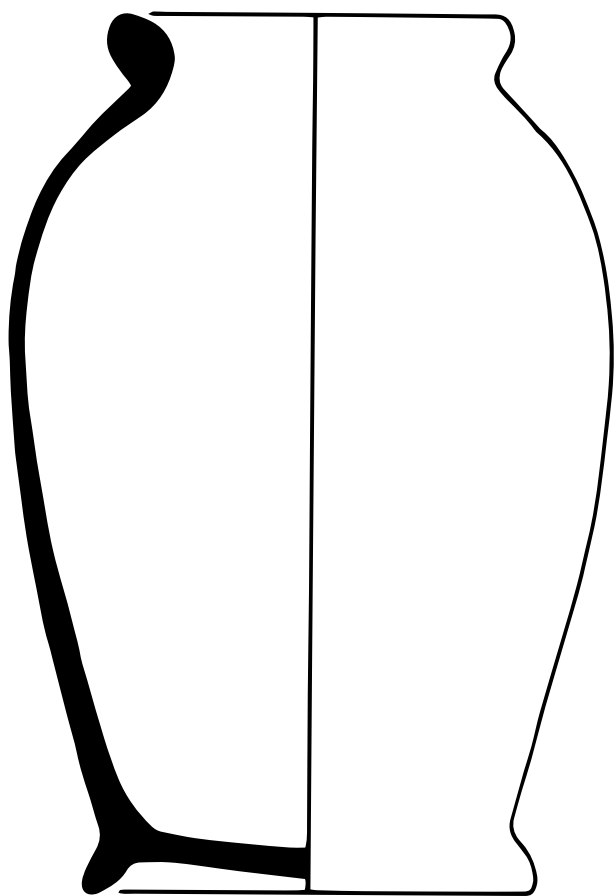

a

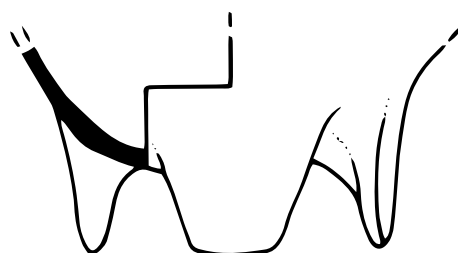

b

## SECTION 10: MISCELLANEOUS FORMS

---

### Contents

#### Introduction to MISCELLANEOUS FORMS

10.1 AMPHORA

10.2 AQUAMANILE

10.3 BEDPAN

10.4 BIRD POT

10.5 CHEESE PRESS

10.6 CHICKEN FEEDER

10.7 COSTREL

10.7.1 Barrel Costrel

10.7.2 Cylindrical Costrel

10.7.3 Mammiform Costrel

10.7.4 Standing Costrel

10.8 CRUET

10.9 DOUBLE DISH

10.10 FEEDING VESSEL

10.11 FIGURINE SALT

10.12 FISH SMOKER

10.13 FISH TRAP

10.14 FLOWER POT

10.15 GRENADE

10.16 HORN

10.16.1 Curved Horn

10.16.2 Extended Horn

10.16.3 Coiled Horn

10.17 INKWELL

10.18 LAVABO

## 10.19 MERCURY JAR

## 10.20 MILK CHURN

## 10.21 MONEY BOX

- 10.21.1 Domed Money Box
- 10.21.2 Mammiform Money Box
- 10.21.3 Knobbed Money Box
- 10.21.4 Zoomorphic Money Box

## 10.22 MORTAR

## 10.23 OLIVE JAR

- 10.23.1 Carrot-shaped Olive Jar
- 10.23.2 Globular Olive Jar
- 10.23.3 Rounded Olive Jar
- 10.23.4 Handled Olive Jar

## 10.24 RING VASE

## 10.25 RING-HANDLED VASE

## 10.26 SALT KIT

## 10.27 SPITTOON

## 10.28 URINAL

- 10.28.1 Basket-handled Urinal
- 10.28.2 Side-handled Urinal

## 10.29 WATERING POT

- 10.29.1 Sprinkler Watering Pot
- 10.29.2 Rose-type Watering Pot

## 10.30 WHISTLE

### Introduction to MISCELLANEOUS FORMS

This section is arranged in strict alphabetical order by form. It includes all those forms which do not fit easily within the previous seven sections, although for some (e.g. CRUET, MILK CHURN, MORTAR) the range encompasses individual forms which could be individually classified in other sections.

## 10.1 AMPHORA

**Defining characteristics:** The term AMPHORA is used to describe JARS made for transportation of liquids such as olive oil or wine, or other substances such as honey or preserved fruit, and should be used with caution. It has been applied to sub-Roman Mediterranean forms (e.g. 'B ware') and to other forms with sub-Roman origins. These have been classified by shape (Peacock and Williams 1986, 182-90 and see a-c, below; Thomas 1959).

The term has also been used for Relief-band decorated vessels from the Badorf area of Germany (see d, below). This type generally takes the form of a large, thick-walled JAR with rounded profile and no discernible base angle.

It is recommended that the term should be restricted to these products. AMPHORAE should not be confused with the later Mediterranean vessels which are classified here as OLIVE JARS (see 10.23).

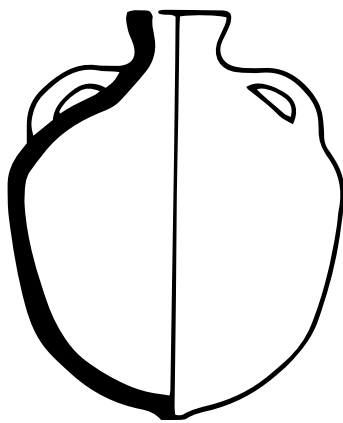

a

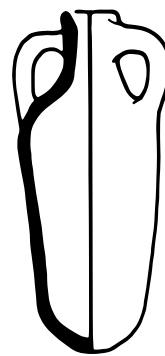

b

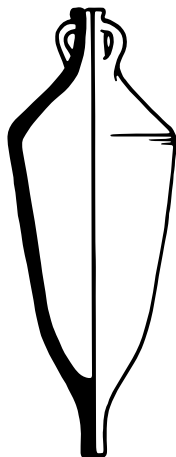

c

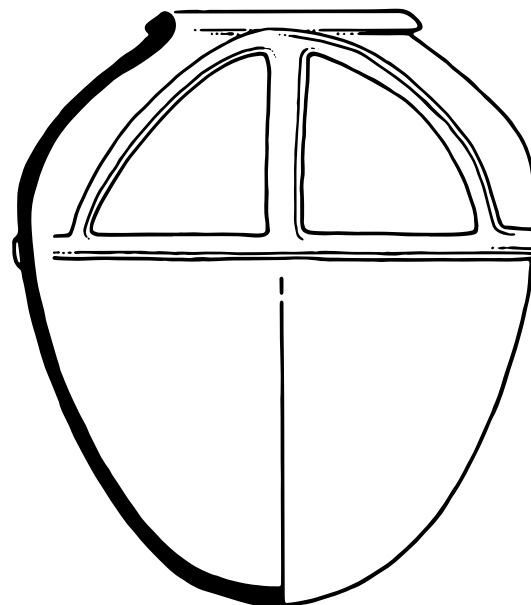

d

## 10.2 AQUAMANILE

**Defining characteristics:** A vessel made in zoomorphic form, sometimes combined with human figures. The best-known examples represent horses with riders. The vessel is filled through a hole or device in the top of the body and liquid is poured out through the beast's mouth.

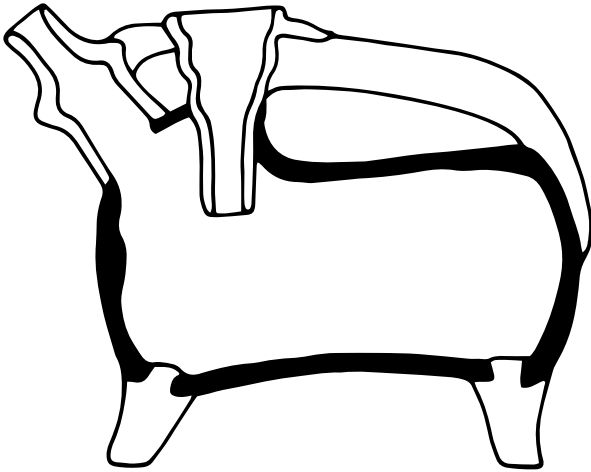

a

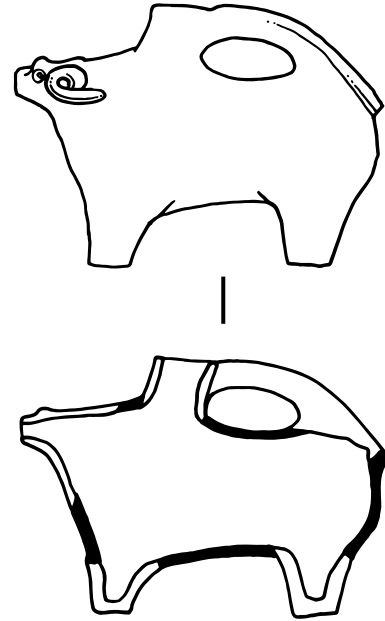

b

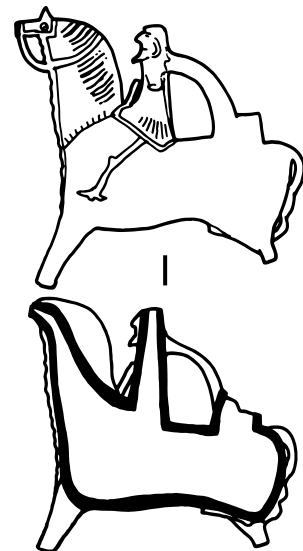

c

### 10.3 BEDPAN

**Defining characteristics:** A large, deep DISH with an inturned rim. On one side, there is single, long, horizontal, *tubular handle*, open at both ends.

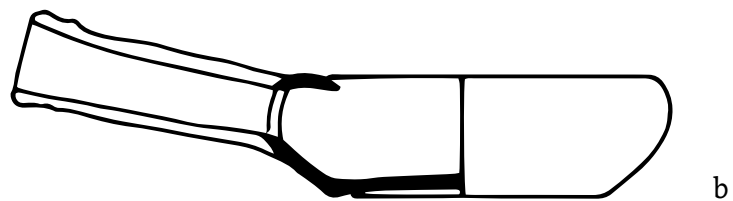
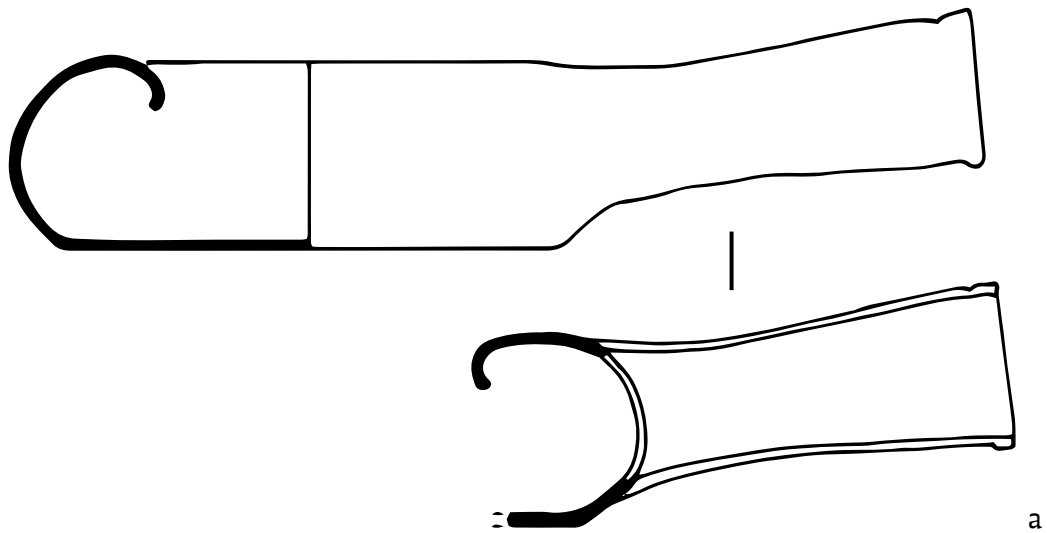



### 10.4 BIRD POT

**Defining characteristics:** A vessel with narrow neck and rounded body, with a *cut-out* in the base. Two types are described here.

The simpler form is designed to be mounted at right angles to the wall (see **b**, below). The cut-out section in the base has a notch for hanging it up. The short *handle*, which is attached to the neck, is pierced in line with a hole in the vessel shoulder. These holes are used to support a stick which acts as a perch for birds (see below).

The more elaborate type has a *loop handle* attached to the body for suspension, and the side of the body is flattened to rest against the wall. *Pierced lugs* on the neck support the perch. A removable plate, which could be secured by means of a stick, is fitted over the base (see **a**, below; base cover not shown).

**Bibliography:** Stephenson 1991.

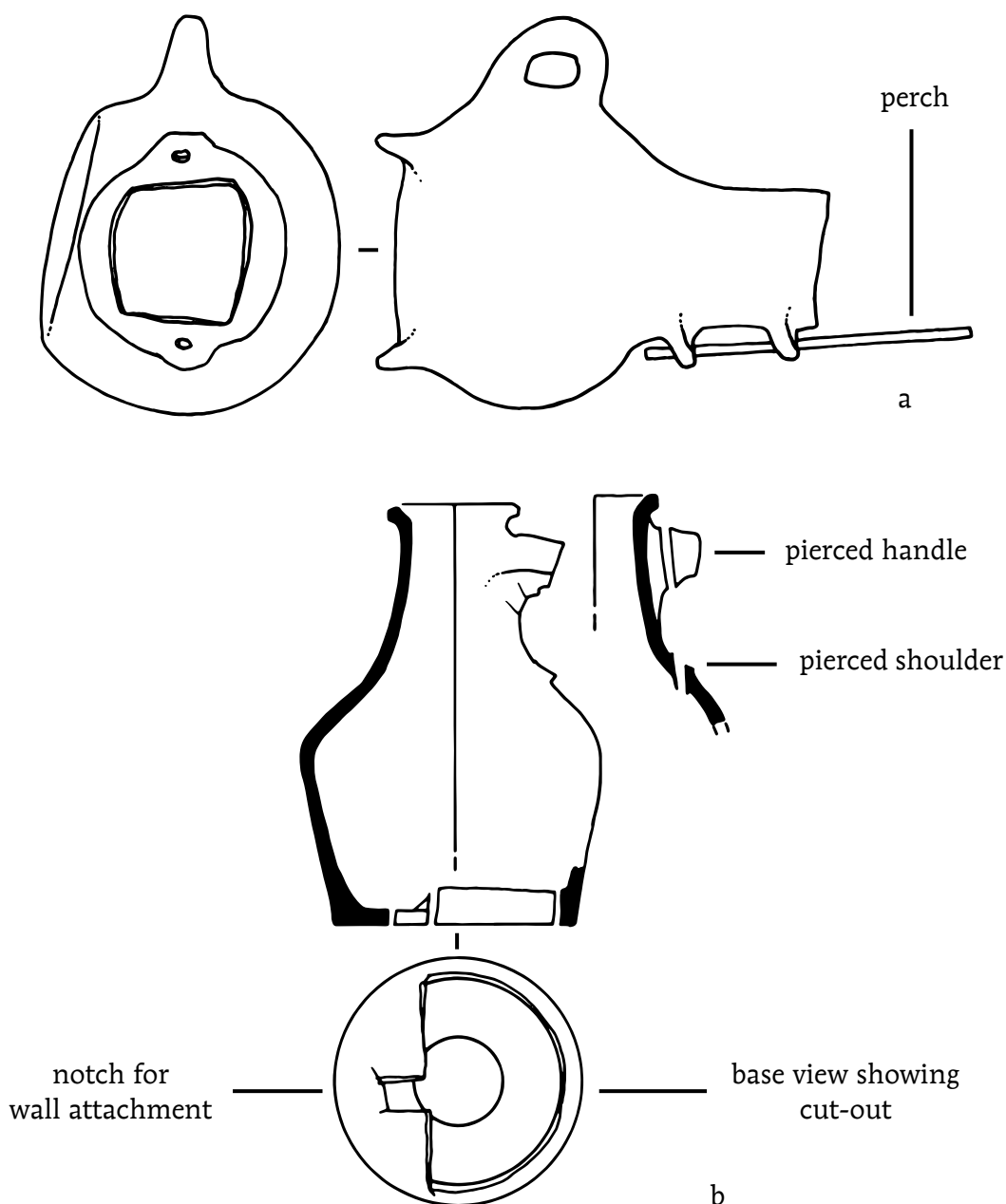

### 10.5 CHEESE PRESS

**Defining characteristics:** A BOWL or DISH with pierced holes around the edge of the base for draining off liquids; it may also have drainage grooves in the base.

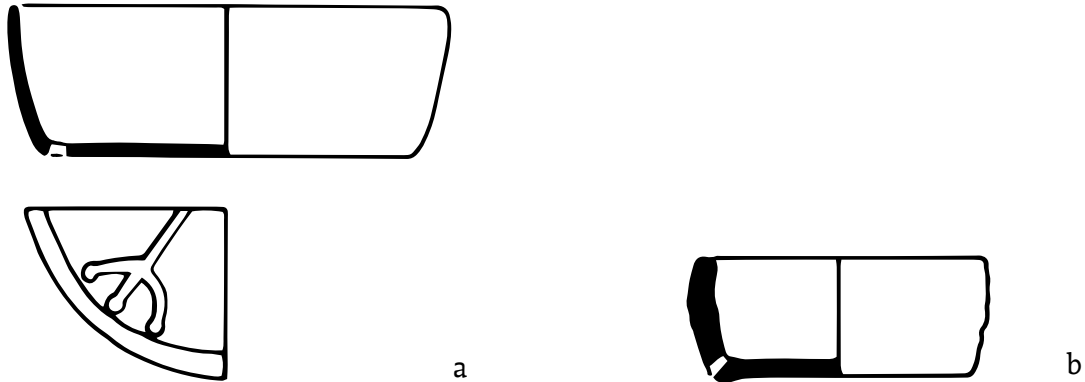

### 10.6 CHICKEN FEEDER

**Defining characteristics:** A wide, shallow, straight-sided, circular DISH with concentric divisions, formed either by vertical *partitions*, or by concentric grooving around the base.

These vessels are rare ceramic forms and their function remains uncertain; although their name implies that they may be designed to hold feed for domestic fowl, they may have held water for chicks.

**Alternative name:** Small examples may be Beetle Traps.

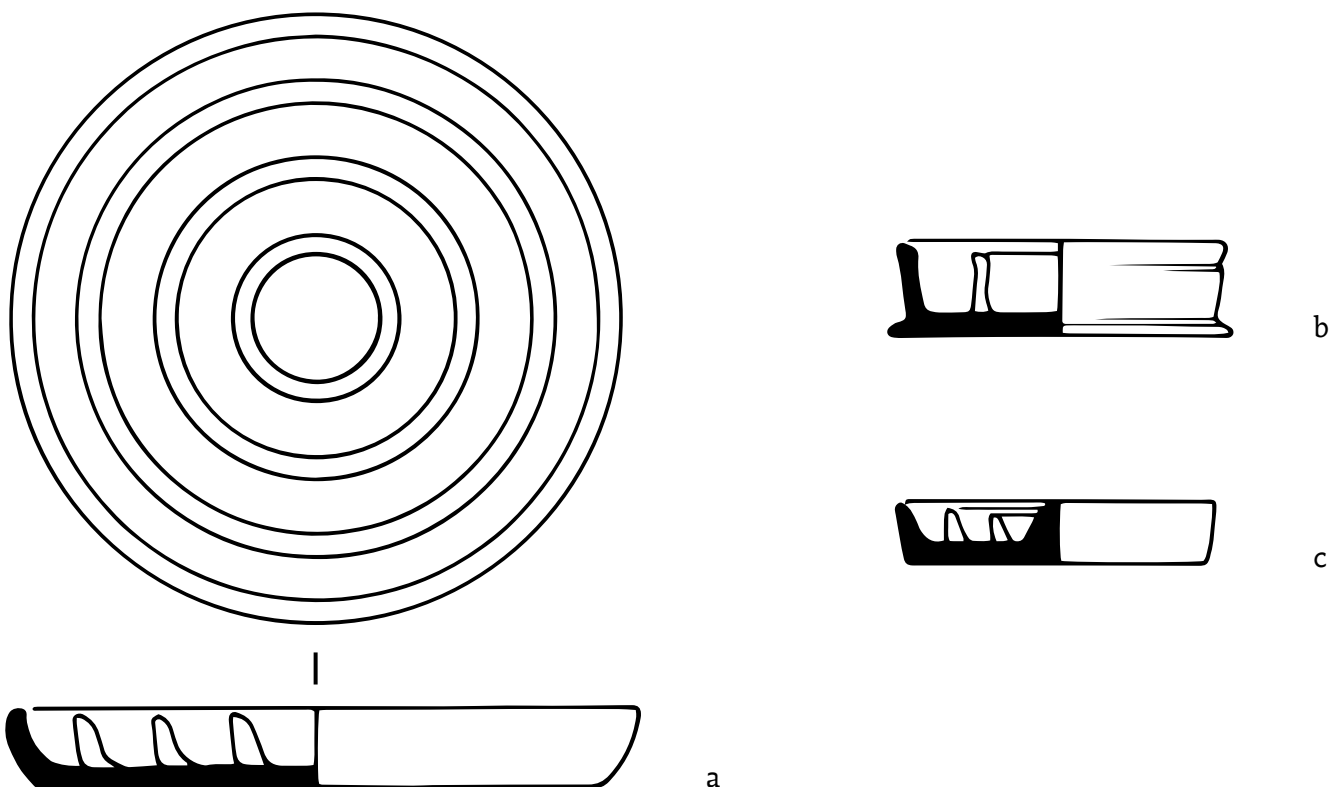

## 10.7 COSTREL

**Defining characteristics:** A vessel with a narrow neck added to the body, generally designed to be suspended with the neck upright. Two or more *handles* are attached to the neck or shoulder; they are usually *pierced lugs* or short *strap handles* designed to hold suspension cords.

COSTRELS are classified by **profile**:

- 10.7.1 Barrel Costrel
- 10.7.2 Cylindrical Costrel
- 10.7.3 Mammiform Costrel

A fourth form does not strictly fit the definition above, but has been included here because the term is in common usage.

- 10.7.4 Standing Costrel

**Bibliography:** Dunning 1964.

## 10.7 COSTREL

## Costrel Forms

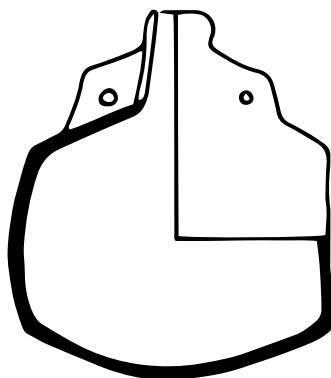

barrel costrel

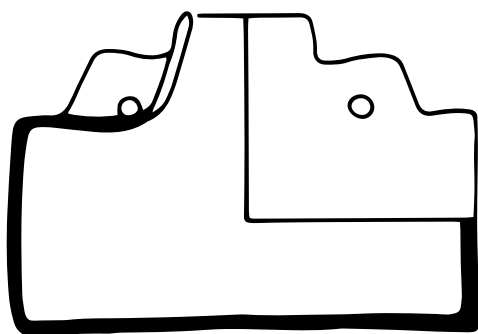

cylindrical costrel

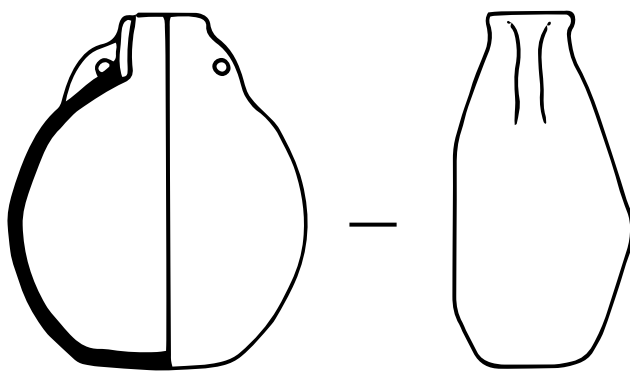

mammiform costrel

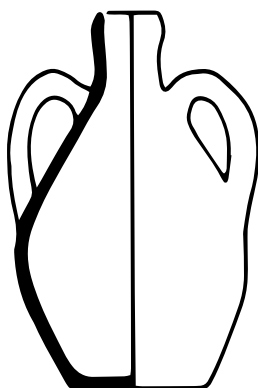

standing costrel

## 10.7.1 COSTREL

## Barrel Costrel

**Defining characteristics:** A COSTREL with a barrel-shaped body and a centrally placed neck. One end is usually flat and the other domed. Two opposed *strap handles* or *lugs* join the rim or neck and shoulder.

Continental examples generally have *strap handles*, while English examples have *pierced lugs*.

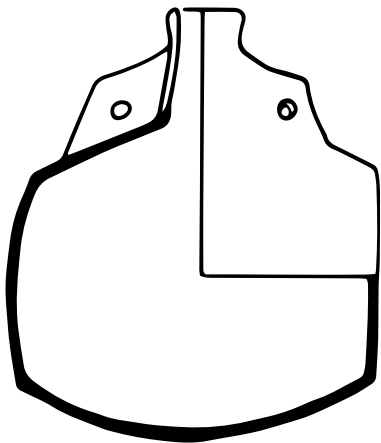

a

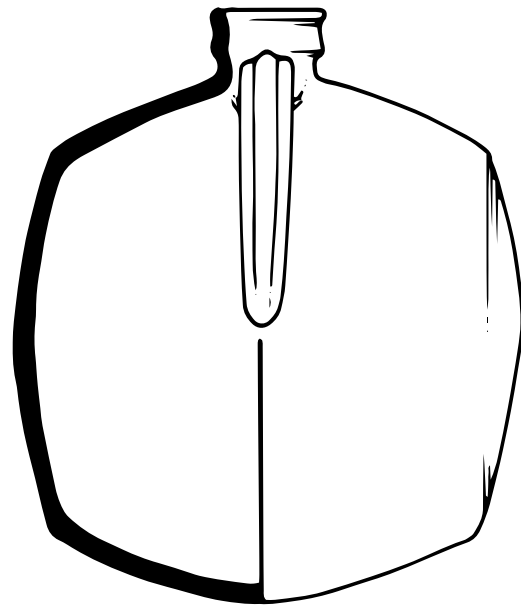

b

## 10.7.2 COSTREL

## Cylindrical Costrel

**Defining characteristics:** A COSTREL with a cylindrical body and a centrally placed neck. One end is domed and the other flat. Two opposed *strap handles* or *lugs* may join rim or neck and shoulder.

Continental examples generally have *strap handles*, while English examples have *pierced lugs*.

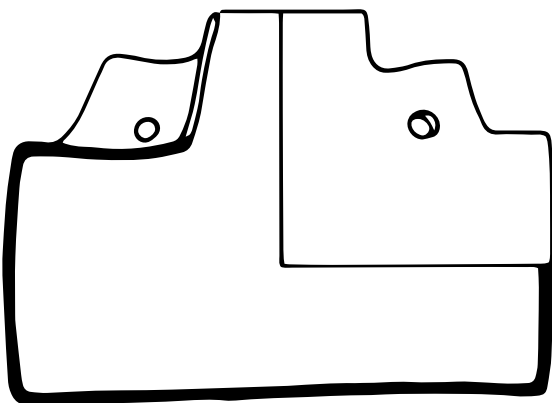

a

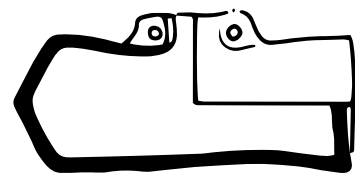

b

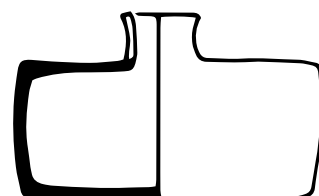

c

### 10.7.3 COSTREL

#### Mammiform Costrel

**Defining characteristics:** A COSTREL with a flattened spherical form; the back is flat and the front domed or mammiform. The base may be slightly flattened or rounded. Two opposed *strap handles* or *lugs* join the rim or neck and shoulder, generally in the same plane as the circumference of the vessel.

**Variations:** *Strap handles* may be placed on the shoulder, looping over from back to front; there may be multiple straps. The base may be provided with *pulled feet*, or an applied *footring*.

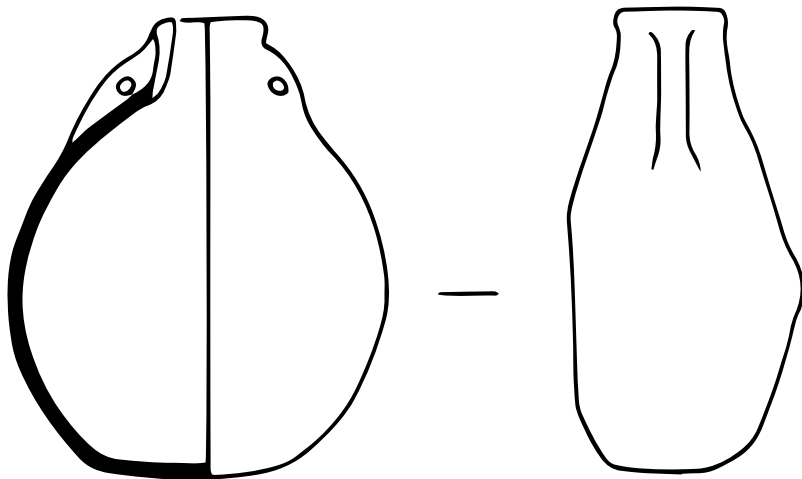

a

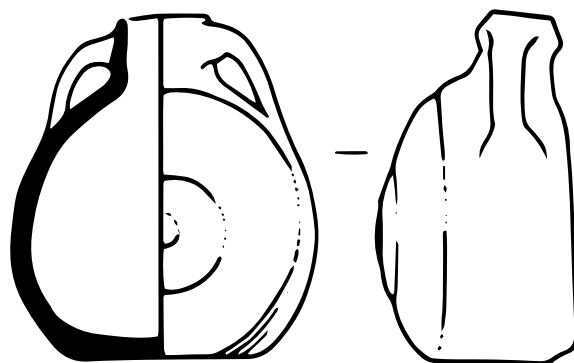

b

### 10.7.4 COSTREL

### Standing Costrel

**Defining characteristics:** A narrow-mouthed vessel with two opposed *handles* or *lugs* on the shoulder. The English examples often have two opposed lugs (see c, below). Types with vertical *loop handles* (see a and b, below) are generally Continental (see Hurst *et al.* 1986, fig. 28, no. 75; fig. 32, no. 90).

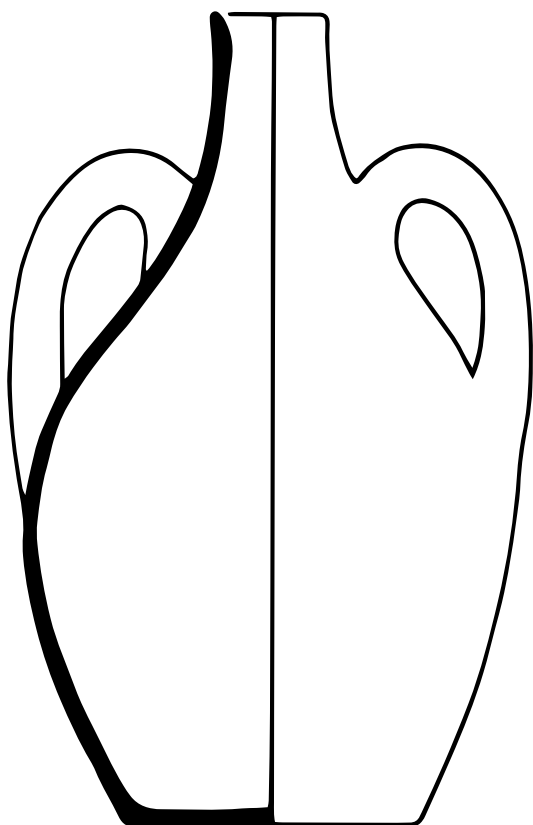

a

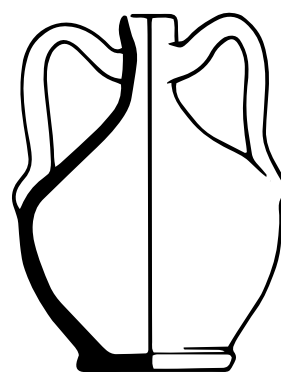

b

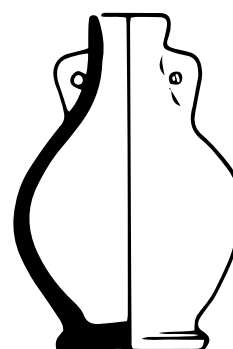

c

### 10.8 CRUET

**Defining characteristics:** A small JUG (with handle) or BOTTLE (without handle), with a *pinched* or *thumbed applied strip* around the girth.

These are rare ceramic forms, copies of metal vessels, with a specific religious function, and should not be confused with the modern use for the term.

**Bibliography:** Dunning 1969; Lewis 1968.

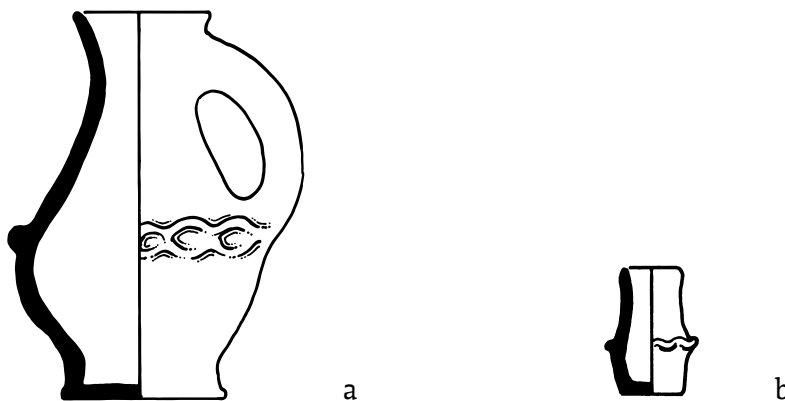

### 10.9 DOUBLE DISH

**Defining characteristics:** A deep, straight-sided vessel, usually sub-rectangular in plan. A slightly shallower compartment is attached to the long side of the main vessel. This secondary compartment has a pierced base. The vessel may have vertical or horizontal *loop handles* or *lugs*, one at each narrow end of the main compartment.

This is a rare ceramic form, presumably with a specific function which remains unknown.

**Bibliography:** Pearce 1992, 42, fig. 46, nos. 447-8.

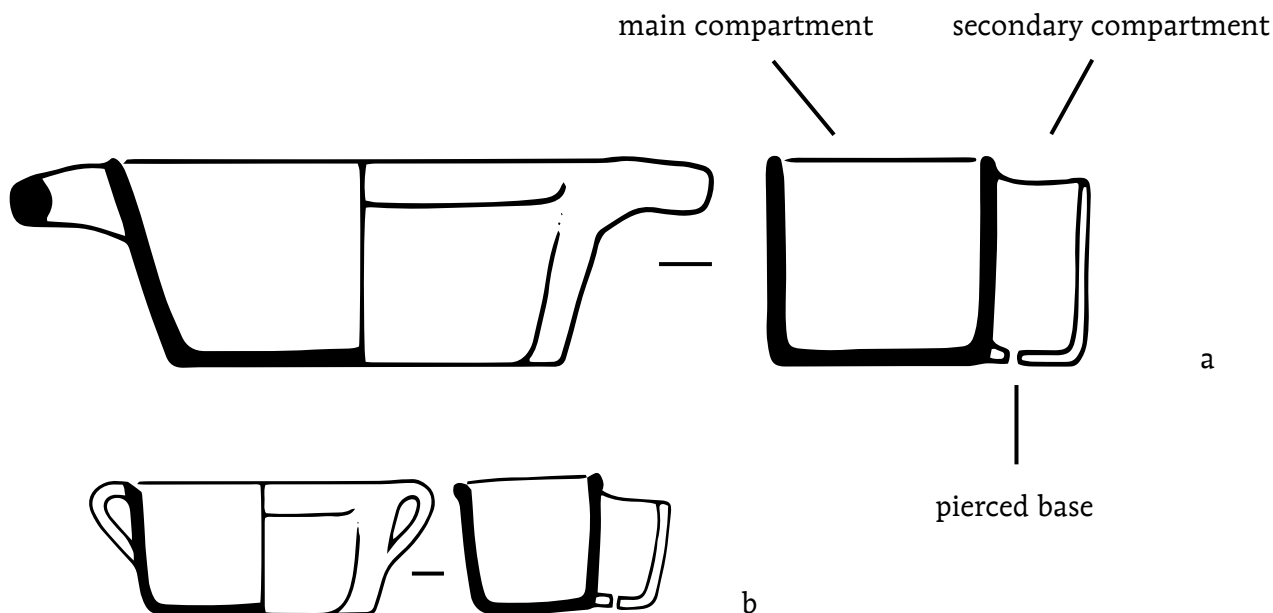



## 10.10 FEEDING VESSEL

**Defining characteristics:** A small vessel of JUG or BOTTLE form, with a *tubular spout* rising from the body, usually used for the feeding of infants or invalids. It may have a *loop handle*.

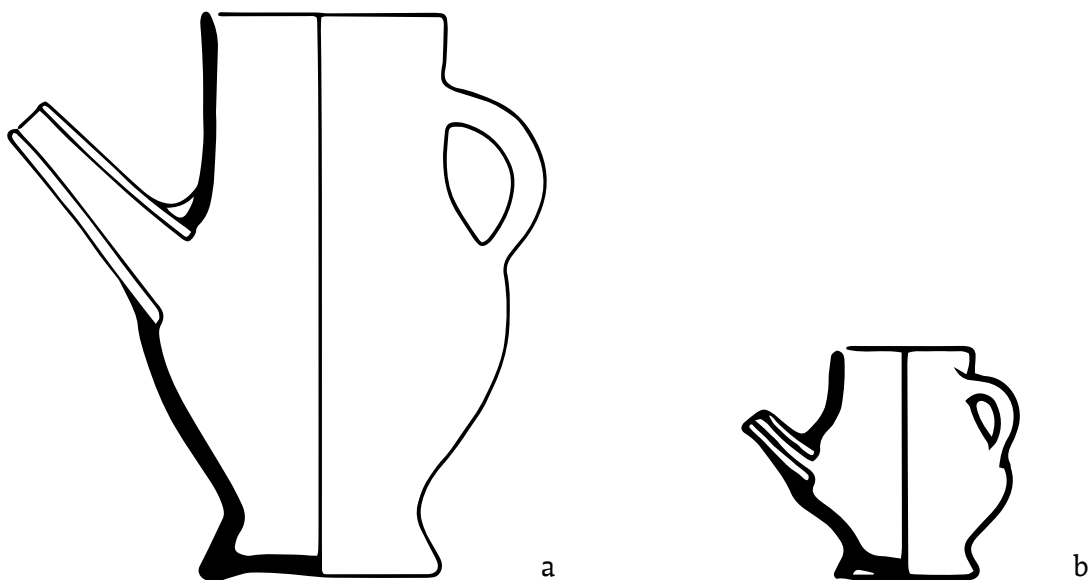

## 10.11 FIGURINE SALT

**Defining characteristics:** A vessel for serving salt at the table, made in the form of a small, moulded figurine holding a DISH which contains the salt. It is an uncommon ceramic form.

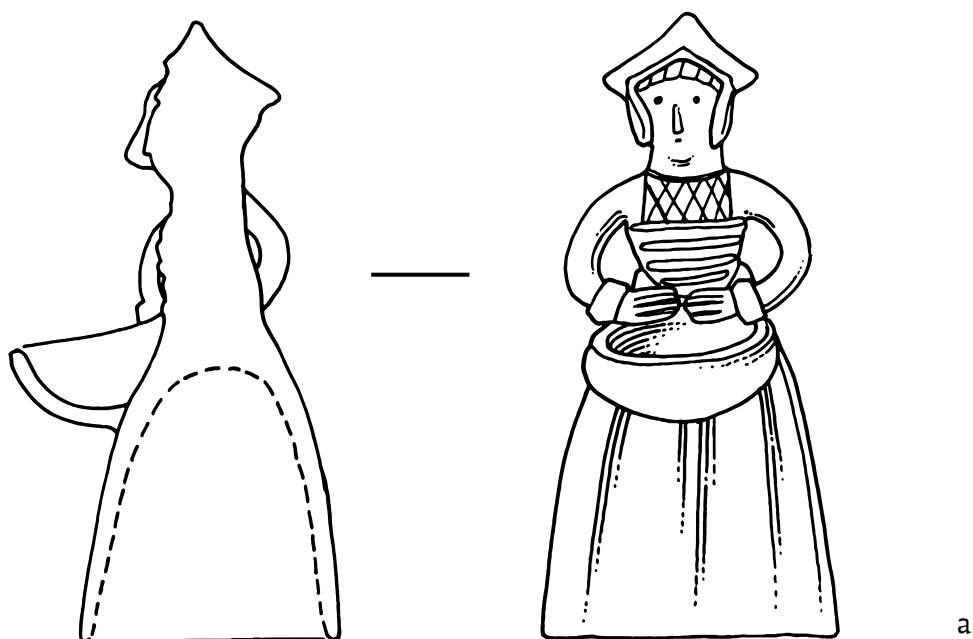

## 10.12 FISH SMOKER

**Defining characteristics:** Similar to a CURFEW, this form resembles an inverted BOWL with a central 'chimney' rising from the top. The vessel walls may also be pierced. Profiles should be classified in the same way as BOWLS (see 5.1.1-5.1.7) or CURFEWS (see 8.5.1-8.5.2)

The function of these vessels remains uncertain, but a connection with the fishery industry has been postulated on the basis of the provenance of some examples (see White 1984).

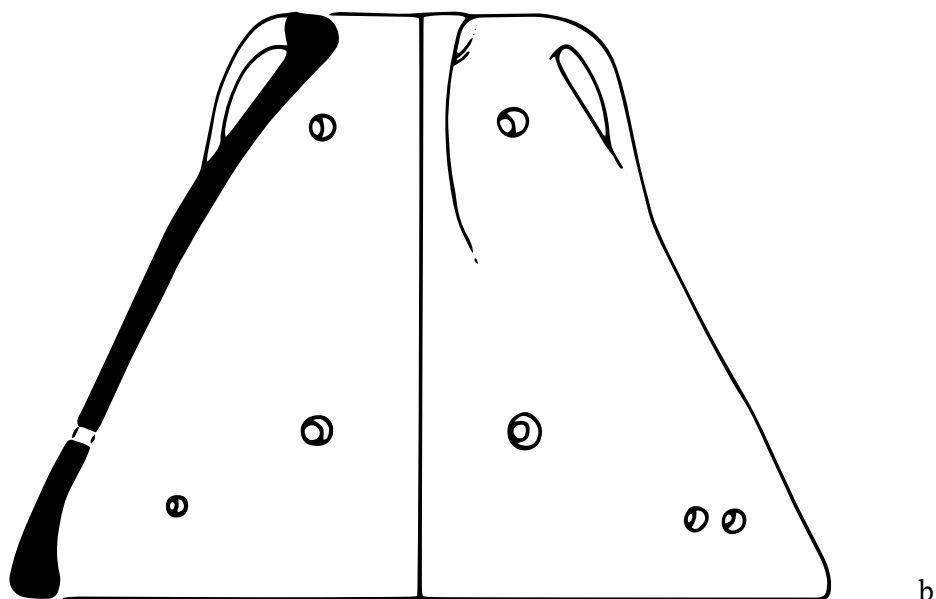
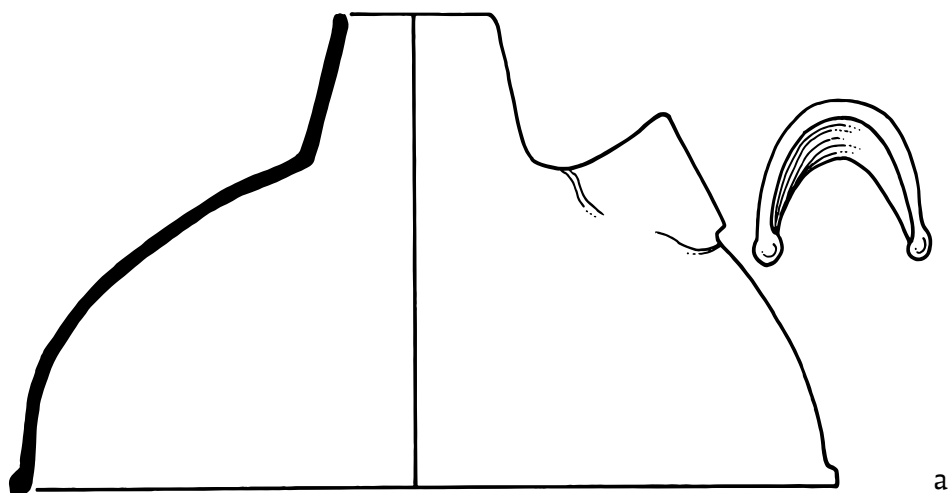

### 10.13 FISH TRAP

**Defining characteristics:** A vessel constructed in the same way as, and presumably imitating, wicker fish traps. It is a waisted form comprising two chambers, with an entrance one end and a narrower exit at the opposite end. Fish enter the first chamber and are funnelled into the second chamber; applied 'teeth' on the inside of the entrance prevent egress. The narrow exit would be secured with a bung or some form of cover.

**Bibliography:** Jennings 1992.

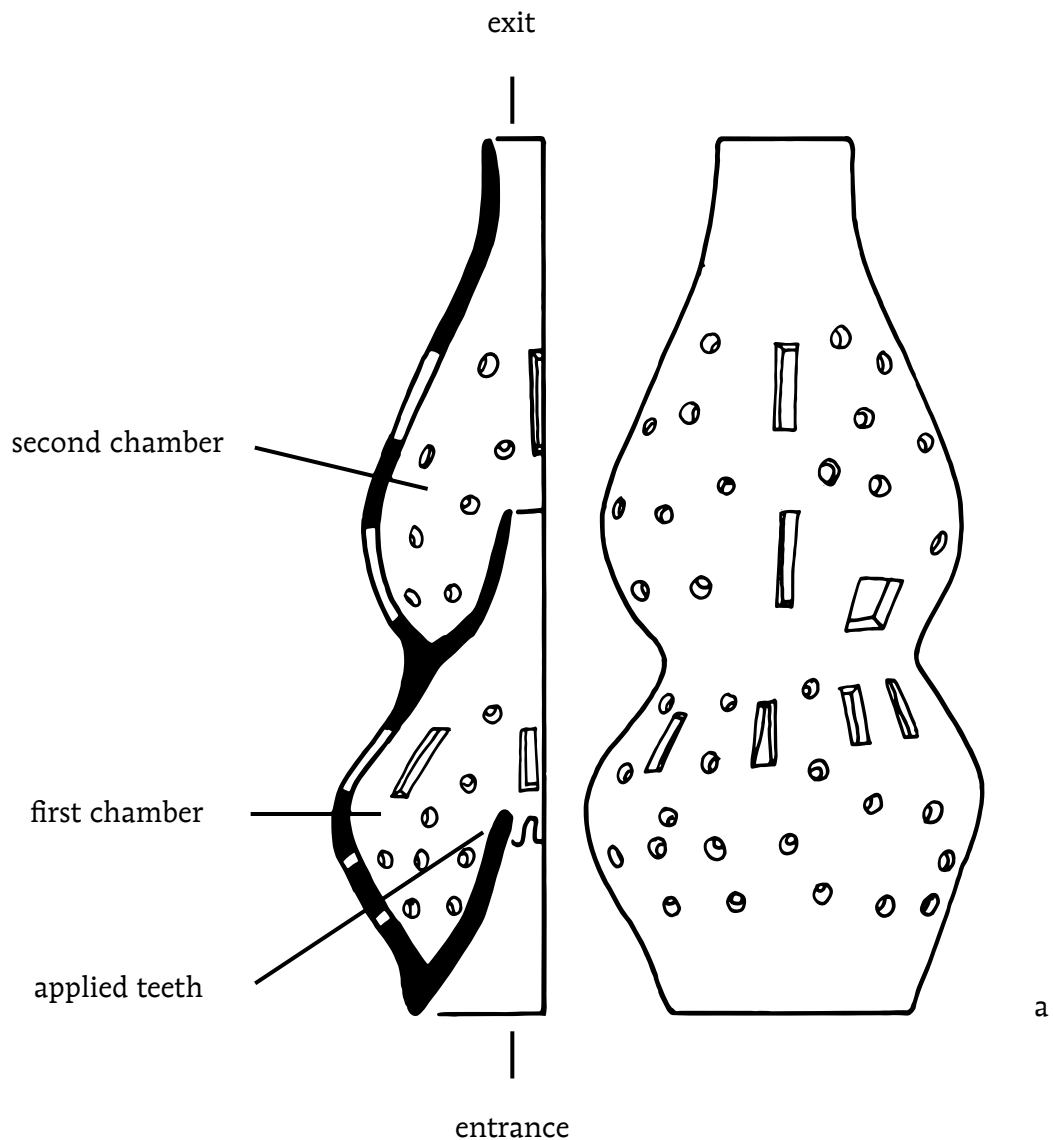

## 10.14 FLOWER POT

**Defining characteristics:** An open vessel, generally of BOWL shape, with pierced hole(s) for drainage, in the base or in the vessel wall just above the base. They may have pierced holes in a wide, *right-angled rim* (possibly for tying down branches that need training, or, as seen in paintings, to hold sticks which form a support frame; see b, below). Some examples are highly ornamental (see d, below).

**Bibliography:** Currie 1993; Moorhouse 1984.

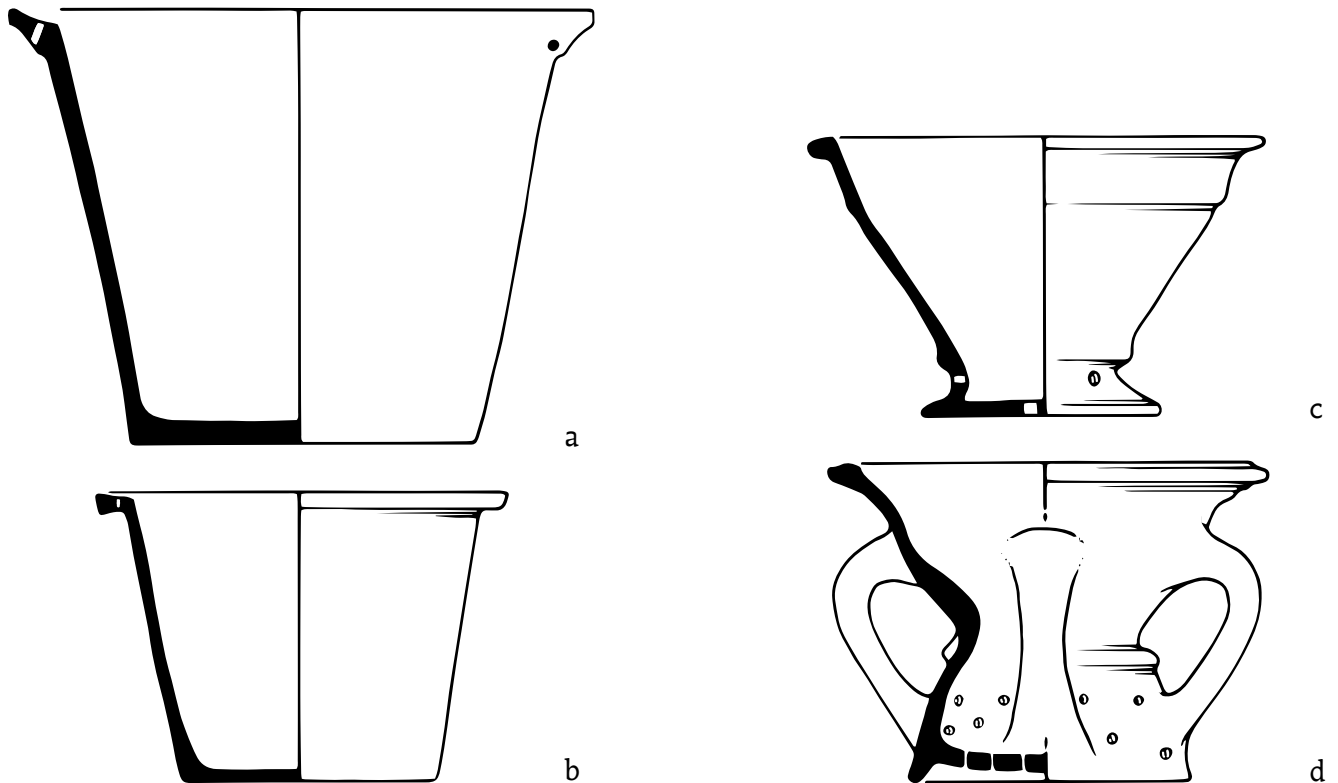

## 10.15 GRENADE

**Defining characteristics:** A closed form but with an opening, sometimes a slot, for the insertion of gunpowder.

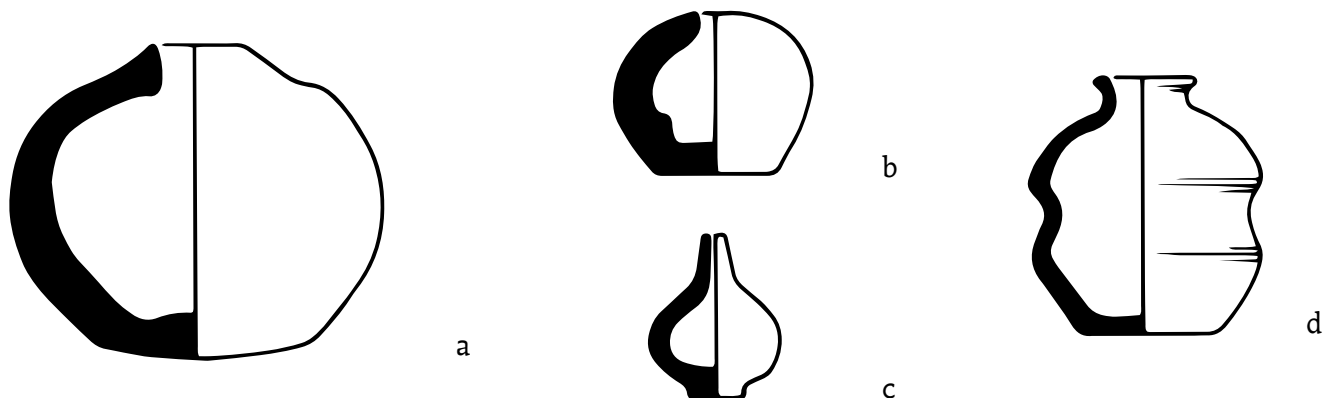

## 10.16 HORN

**Defining characteristics:** A tube with a mouthpiece at one end and flaring outwards to a bell at the other. They may have pierced *lug handles* for suspension and mouthpieces may be simple or shaped.

HORNS should be classified by shape:

- 10.16.1 **Curved Horn:** The simplest form consisting of a short curved length of flaring tube.
- 10.16.2 **Extended Horn:** A longer version of the CURVED HORN.
- 10.16.3 **Coiled Horn:** An EXTENDED HORN curled round into a circle.

**Bibliography:** Le Patourel 1992.

## 10.16 HORN

## Horn Forms

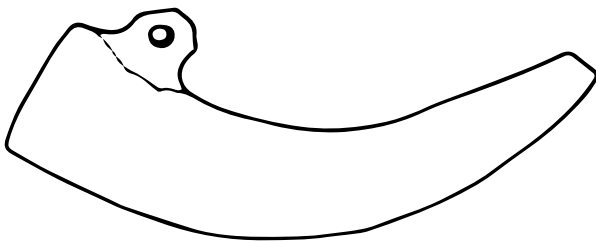

curved horn

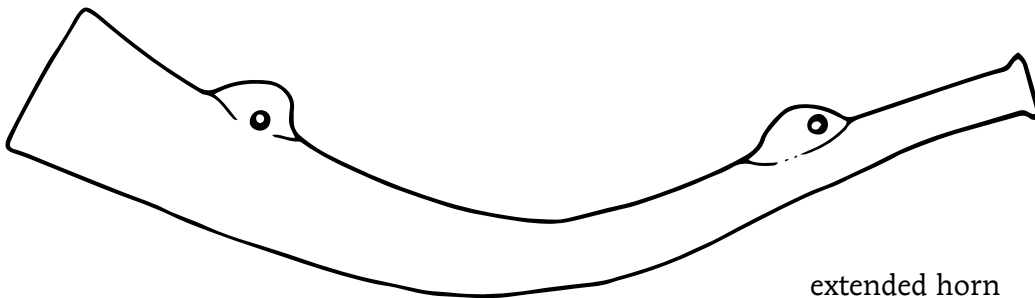

extended horn

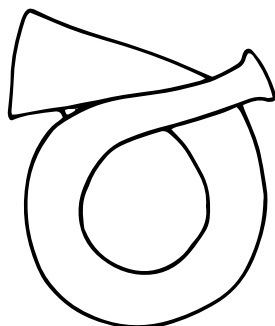

coiled horn

### 10.17 INKWELL

**Defining characteristics:** A thick slab with a reservoir for the ink sunk in one face. There may also be smaller holders for quills and/or a compartment to hold sand for dusting. A rare ceramic form.

**Alternative name:** Inkstand has been used.

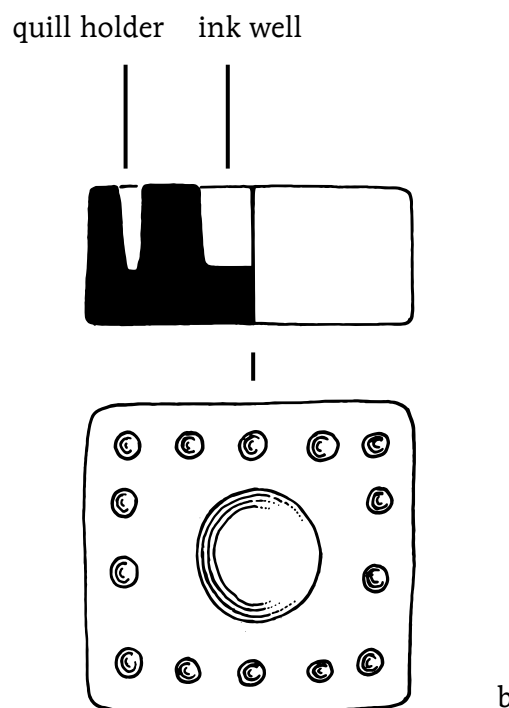
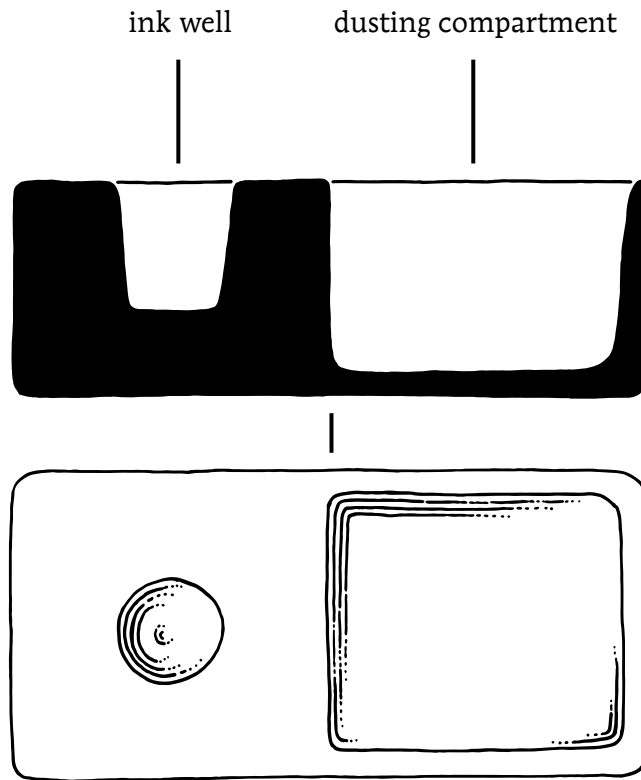

## 10.18 LAVABO

**Defining characteristics:** A globular, narrow-necked vessel holding water for hand-washing and designed to be suspended over a basin. There may be upright *lugs* or *loop handles* for suspension and two or more *tubular spouts*. A rare ceramic form imitating metal vessels.

**Bibliography:** Verhaeghe 1991; Gaimster and Verhaeghe 1992.

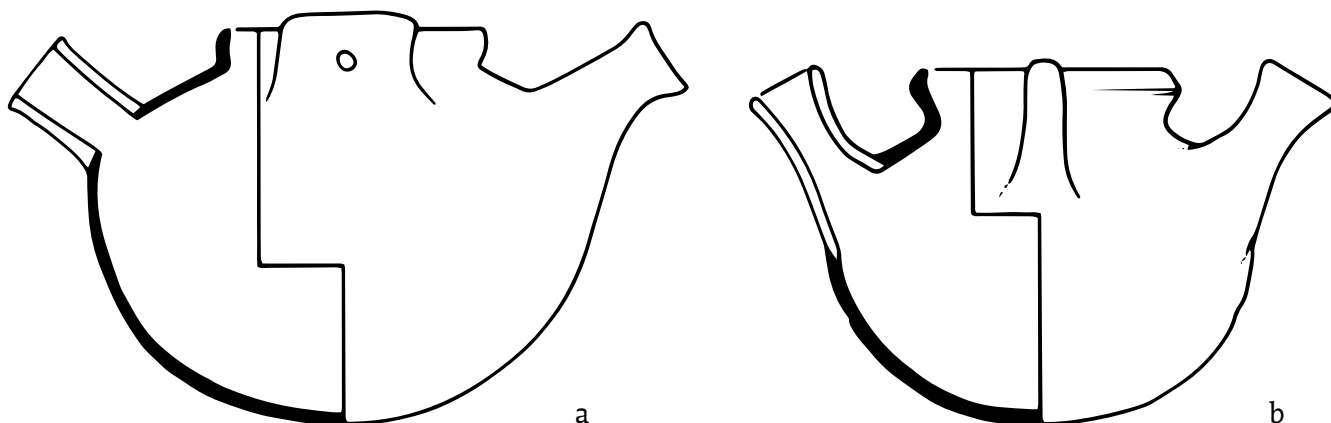

## 10.19 MERCURY JAR

**Defining characteristics:** A small, rounded JAR with very thick vessel walls and an everted rim. Interpretation as containers for mercury is supported by documentary evidence.

**Bibliography:** Brown 1995, p. 321.

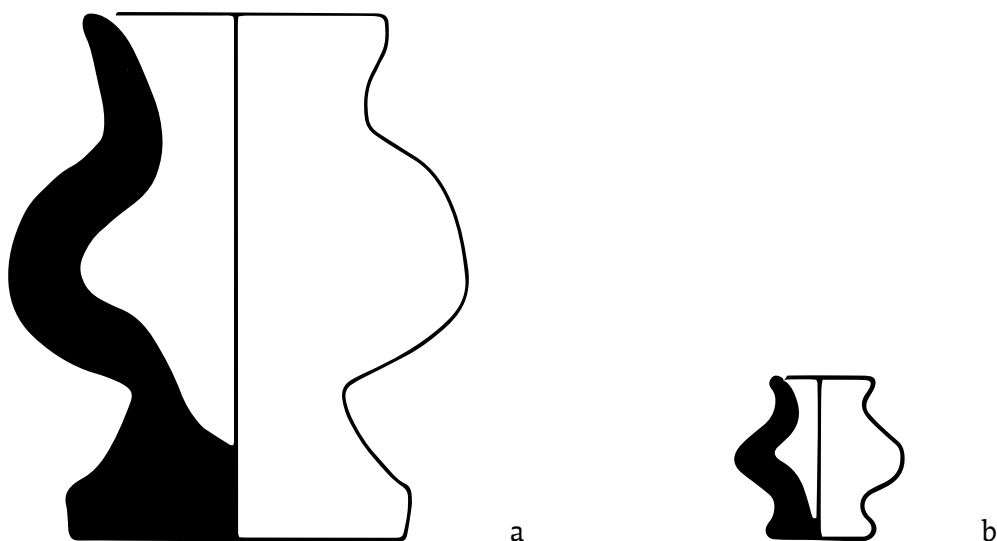

## 10.20 MILK CHURN

**Defining characteristics:** A large, tall, inturned JAR with *handle(s)*. The most common form has two opposed, *horizontal, loop handles* just above the mid point. The *rim* is *lid-seated* to support a pierced lid through which a plunger is worked.

A variant form has a *basket handle* looped over the top of the vessel (see b, below). This type would not have been used for churning.

**Alternative name:** Milk Can has been used.

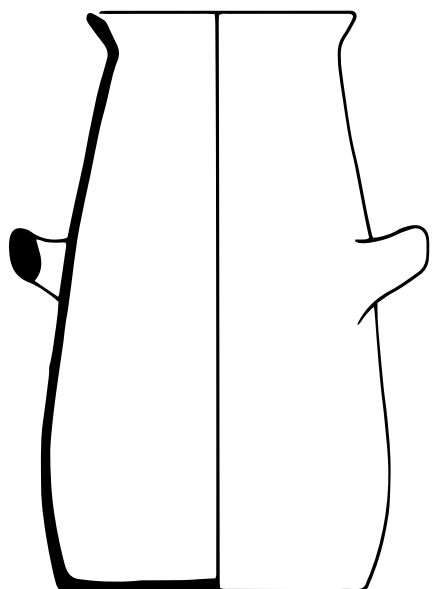

a

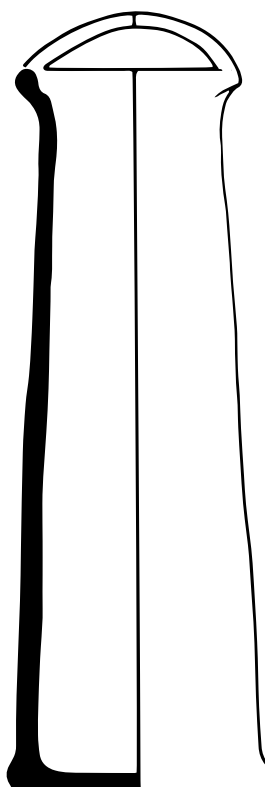

b



## 10.21 MONEY BOX

**Defining characteristics:** An enclosed vessel, usually small, with a slot cut vertically or horizontally in its upper half.

MONEY BOXES are classified by **profile**:

- 10.21.1 Domed Money Box
- 10.21.2 Mammiform Money Box
- 10.21.3 Knobbed Money Box
- 10.21.4 Zoomorphic Money Box

**Alternative name:** Pirlie Pig (regional: Scotland).

## 10.21 MONEY BOX

## Money Box Forms

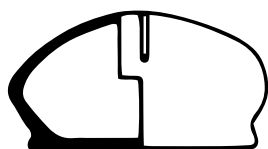

domed money box

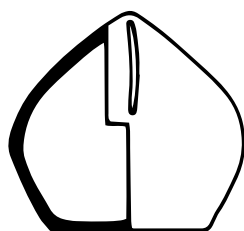

mammiform money box

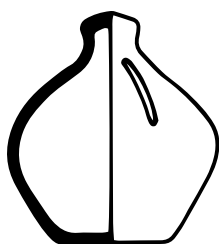

knobbed money box

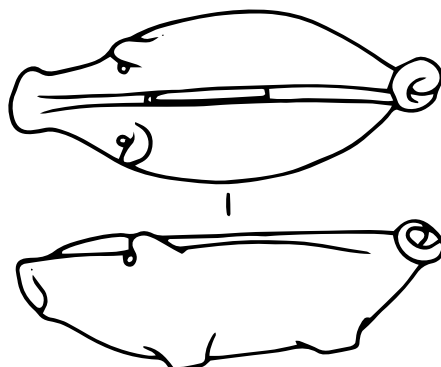

zoomorphic money box

### 10.21.1 MONEY BOX

### Domed Money Box

Defining characteristics: A MONEY BOX with a rounded top and a *flat* or *rounded base*.

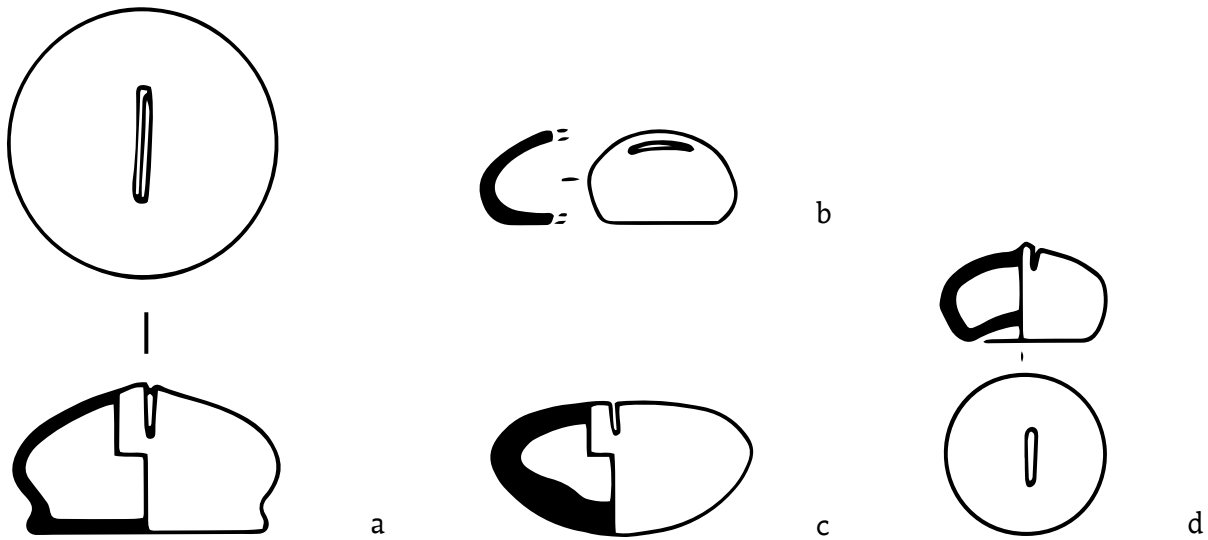

### 10.21.2 MONEY BOX

### Mammiform Money Box

Defining characteristics: A MONEY BOX with a pointed top and a *flat base*. Some forms may have a *pedestal base*.

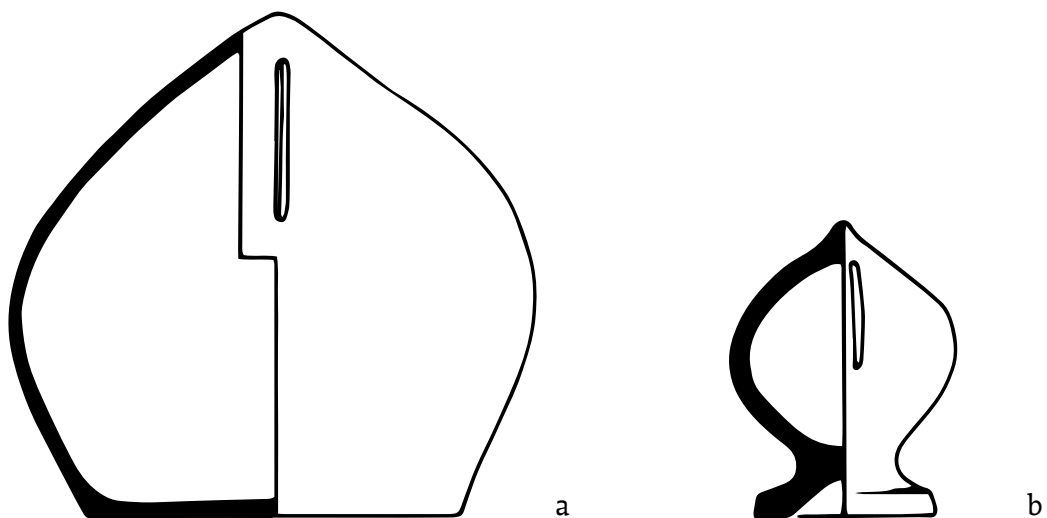

10.21.3 MONEY BOX

Knobbed Money Box

Defining characteristics: A MONEY BOX with a knobbed top.

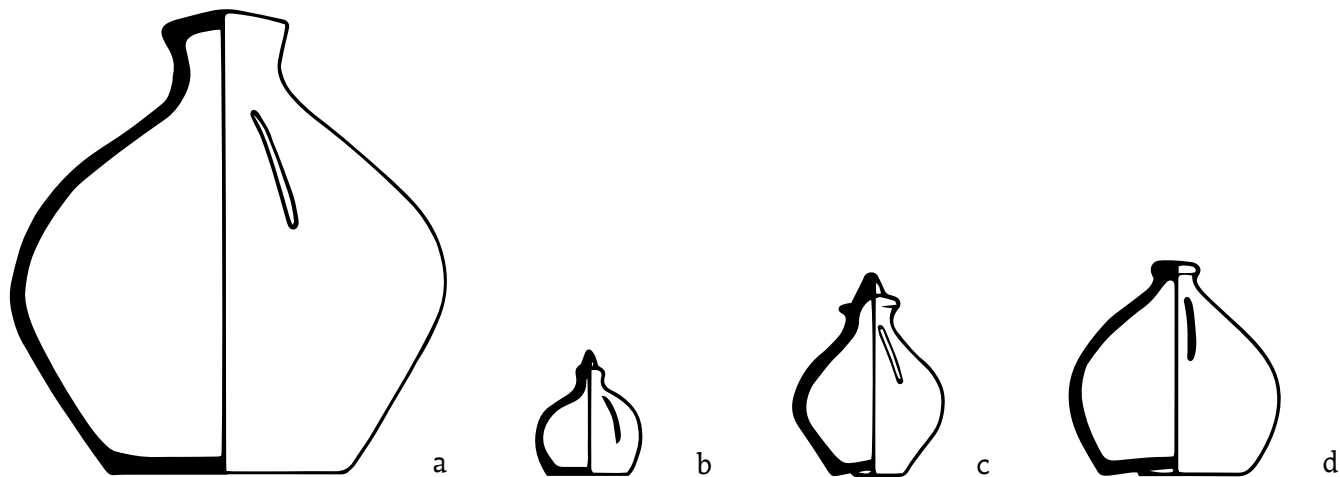

10.21.4 MONEY BOX

Zoomorphic Money Box

Defining characteristics: An elaborate MONEY BOX made in the shape of an animal.

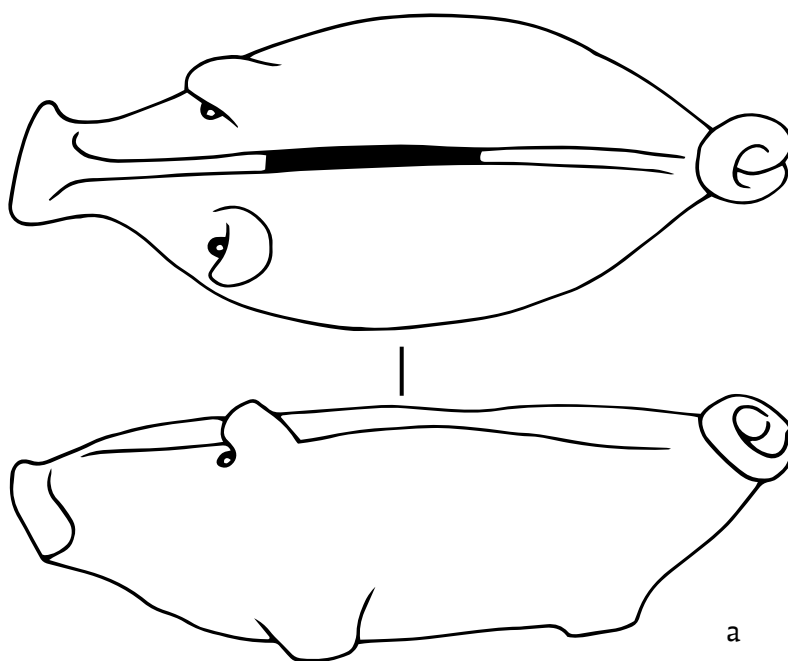

## 10.22 MORTAR

**Defining characteristics:** A thick-walled BOWL with a heavy base and a rounded internal profile with no discernible basal angle. It may have two or more vertical *lug handles* or *loop handles* around the vessel wall, and a *lip*. Profiles vary, and should be classified in the same way as BOWLS (see 5.1.1-5.1.7).

This is a rare ceramic form; most mortars would have been made of stone or metal.

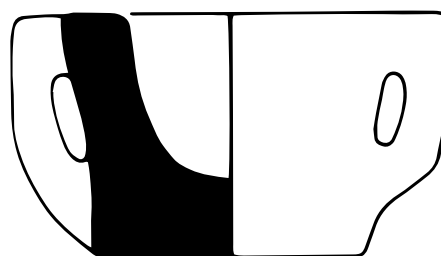
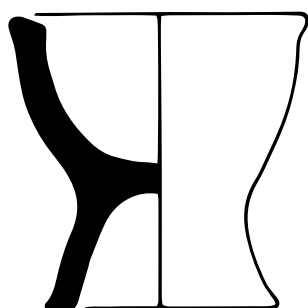
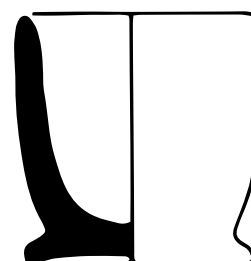
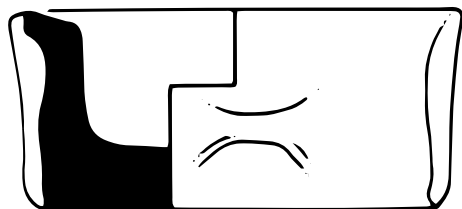
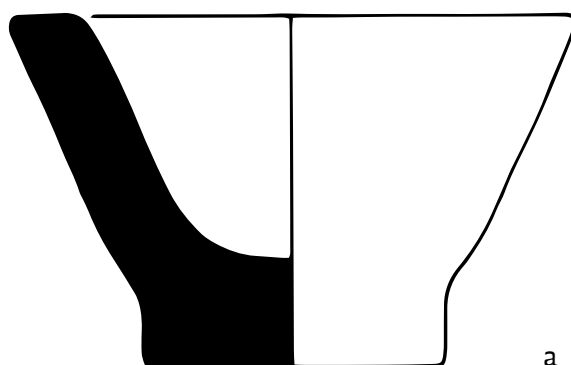

## 10.23 OLIVE JAR

**Defining characteristics:** OLIVE JAR is a functional term used to describe a specific class of late- or post-medieval vessel made for the transportation of liquids such as olive oil or wine, or other substances such as honey or preserved fruit. Most olive jars found in Britain have a provenance in the Iberian peninsula; they are Continental imports and the term should be restricted to these products. Olive jars should not be confused with the earlier vessels of similar function which are classified above as AMPHORAE (see 10.1).

OLIVE JARS are classified by *profile*:

**10.23.1 Carrot-shaped Olive Jar**

**10.23.2 Globular Olive Jar**

**10.23.3 Rounded Olive Jar**

A fourth type has vertical *loop handles*:

**10.23.4 Handled Olive Jar**

**Alternative names:** *Botija* (Spanish), Oil Jar.

**Bibliography:** Hurst (1986) has presented a simple typology, based on work by Goggin (1960), for the three common types of olive jar found in Britain, and this has been followed here.

## 10.23 OLIVE JAR

## Olive Jar Forms

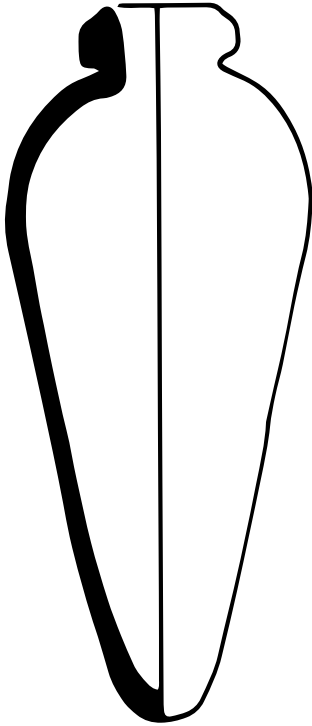

carrot-shaped

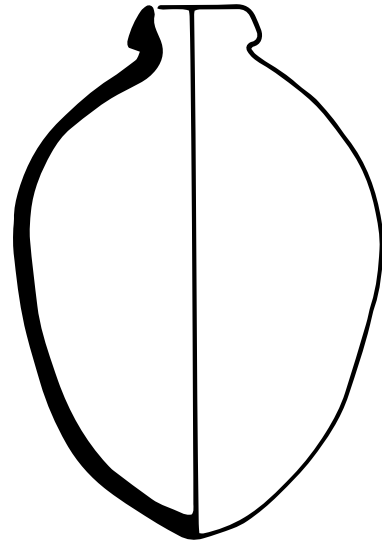

rounded

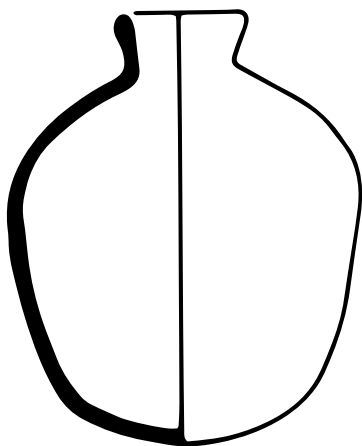

globular

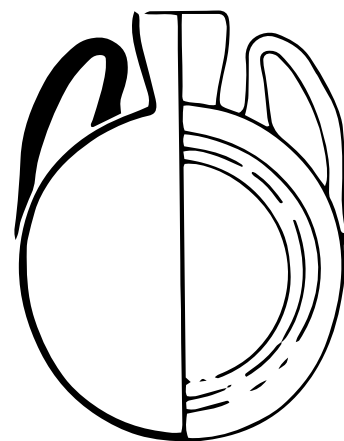

handled

### 10.23.1 OLIVE JAR

### Carrot-shaped Olive Jar

**Defining characteristics:** A tall, thick-walled, narrow-necked JAR, tapering from the shoulders to a narrow, rounded base.

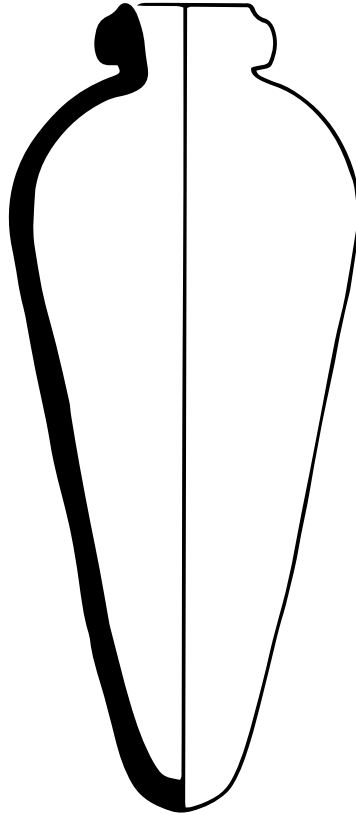

a

### 10.23.2 OLIVE JAR

### Globular Olive Jar

**Defining characteristics:** A thick-walled, narrow-necked JAR with a rounded profile and no discernible basal angle.

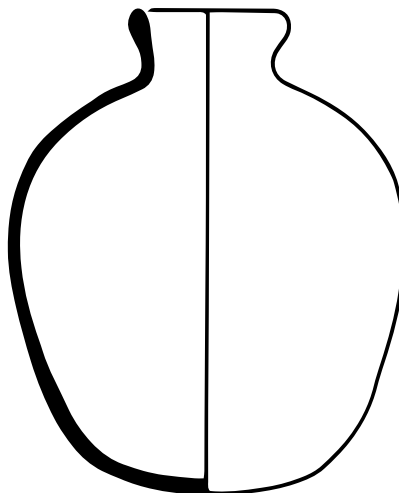

a

### 10.23.3 OLIVE JAR

### Rounded Olive Jar

**Defining characteristics:** A thick-walled, narrow-necked JAR with a rounded profile and a rounded, slightly pointed base.

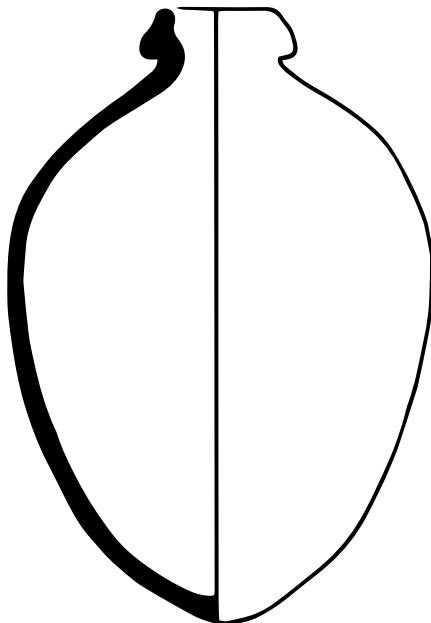

a

### 10.23.4 OLIVE JAR

### Handled Olive Jar

**Defining characteristics:** A narrow-necked vessel with vertical *loop handles* from rim to shoulder. Profiles vary and should be classified as 10.23.1-3.

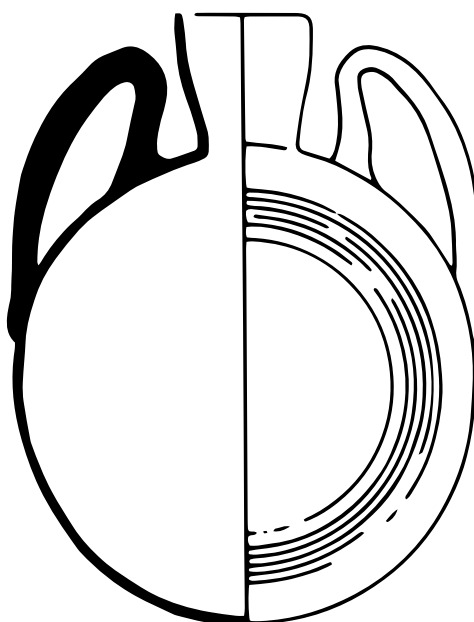

a



## 10.24 RING VASE

**Defining characteristics:** A hollow ring surmounted by a varying number of small CUPS or BEAKERS of biconical or ovoid profile, whose bases are pierced through to the ring body. The vessel may be supported on a *tripod*, and there may be one or more *handles*. Ring vases are frequently decorated and ornate.

**Alternative name:** Ring Lamp has been used.

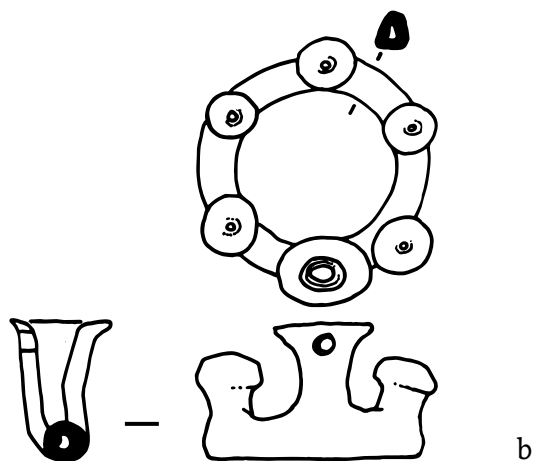
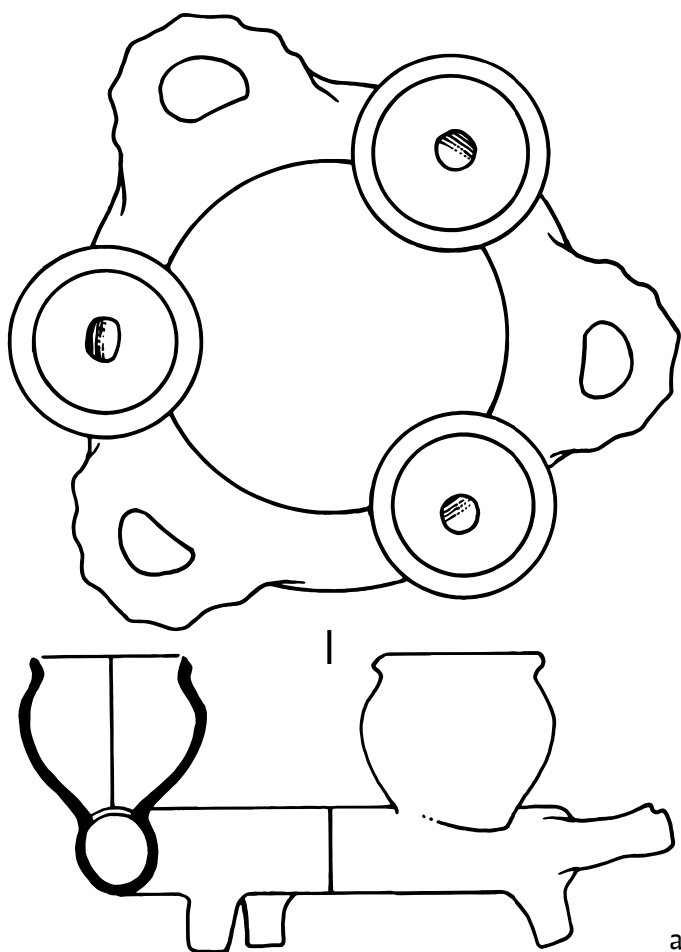

### 10.25 RING-HANDLED VASE

**Defining characteristics:** A vessel with a rounded body profile and a cylindrical or flaring neck. Two opposing *ring handles* are attached where the neck joins the body.

This is typically a tin-glazed form and in England the most common finds of this type are of Low Countries origin. The term vase is strictly inaccurate and stems from early identifications of these vessels as Altar Vases or Flower Vases (Alexander 1970; Hurst *et al.* 1986, 119). It is now so widely used that it has been retained here, although the terms Altar Vase and Flower Vase should no longer be used.

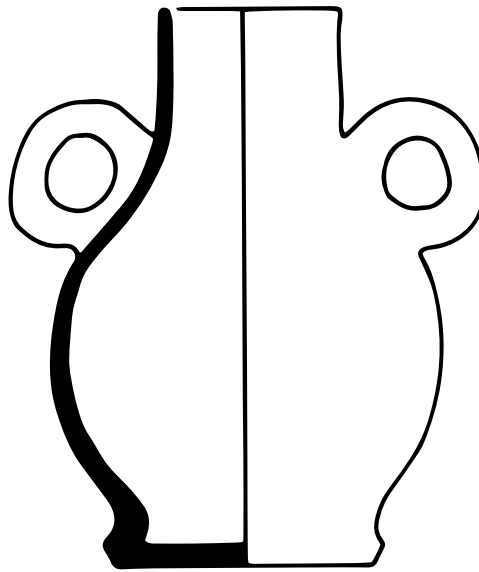

a

### 10.26 SALT KIT

**Defining characteristics:** A squat JAR with a heavy *rim* which may be *lid-seated*. There are opposed *horizontal loop handles* on the shoulder and one or more hooded *cut-outs* in the body wall.

**Alternative name:** Salt Kiln has been used.

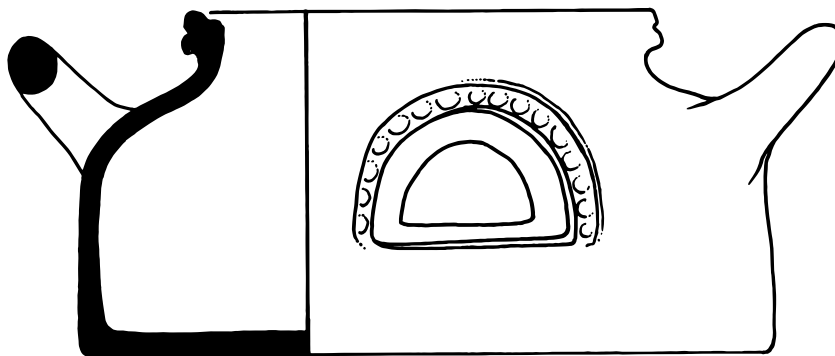

a

## 10.27 SPITTOON

**Defining characteristics:** A vessel with a constricted neck and a long flaring *everted rim*. There are three or more deep vertical grooves or channels running down inside from the rim to the neck and into the body, and three or more vertical ribs applied outside to the rim and neck.

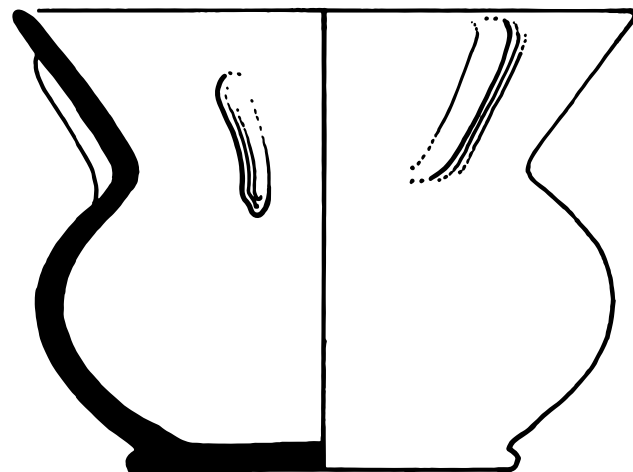
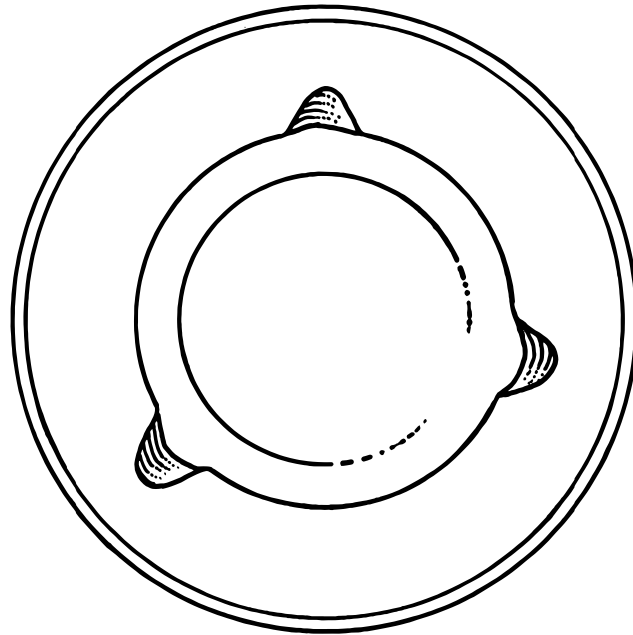

a

## 10.28 URINAL

**Defining characteristics:** A closed, handled form designed for the collection and storage of urine.

Two main forms are known:

### 10.28.1 Basket-handled Urinal

### 10.28.2 Side-handled Urinal

These are forms designed for a specific function, but other ordinary domestic vessels were used for the same purpose, e.g. small JUGS or Drinking Jugs (see 3.1).

## 10.28 URINAL

## Urinal Forms

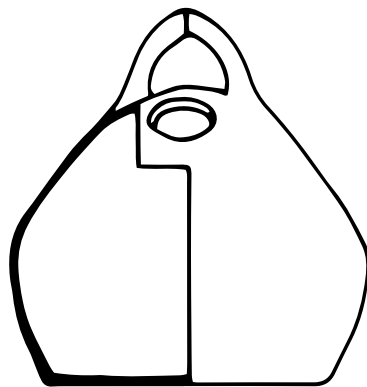

basket-handled urinal

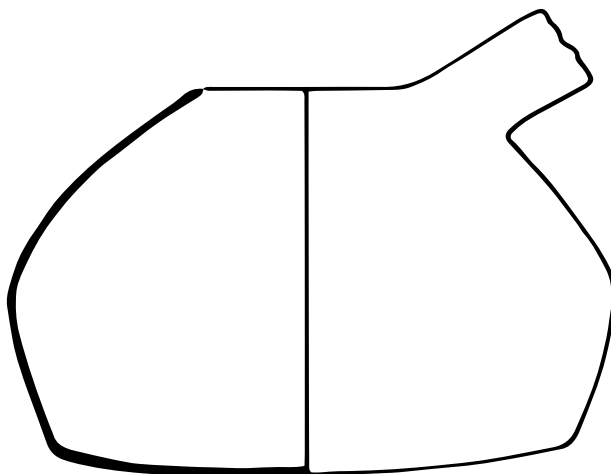

side-handled urinal

### 10.28.1 URINAL

### Basket-handled Urinal

**Defining characteristics:** A rounded, enclosed vessel, with an opening cut in the body wall near the top. A *basket handle* loops over the top of the vessel. On some examples a collar has been added around the opening (see c, below).

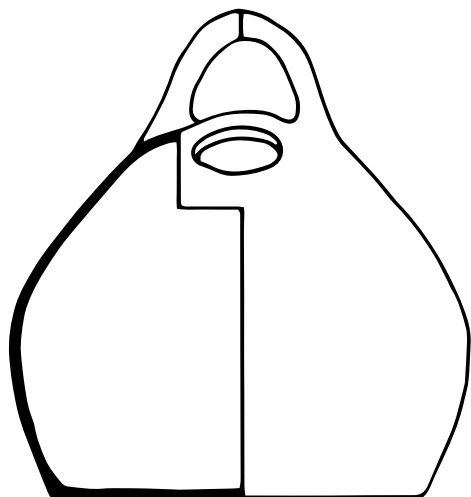

a

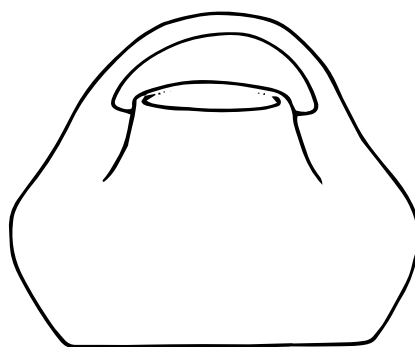

c

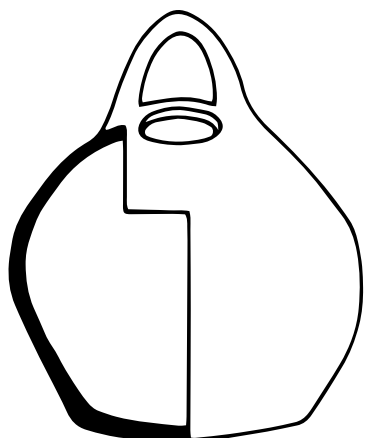

b

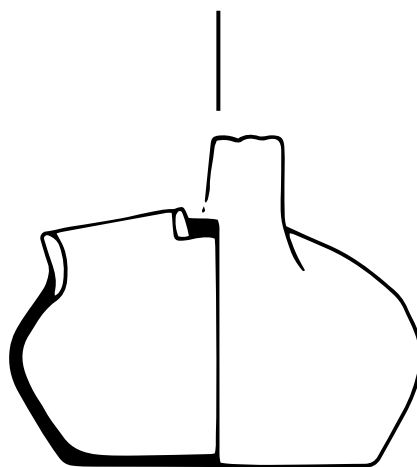

### 10.28.2 URINAL

### Side-Handled Urinal

**Defining characteristics:** A JAR, generally of rounded form, with a narrow mouth and a single, looped, wide *strap handle* attached near the rim. Urinals often have virtually no neck, and the rim is formed on the inward-sloping shoulder. The *handle* usually projects above the rim edge at an angle of approximately 45°.

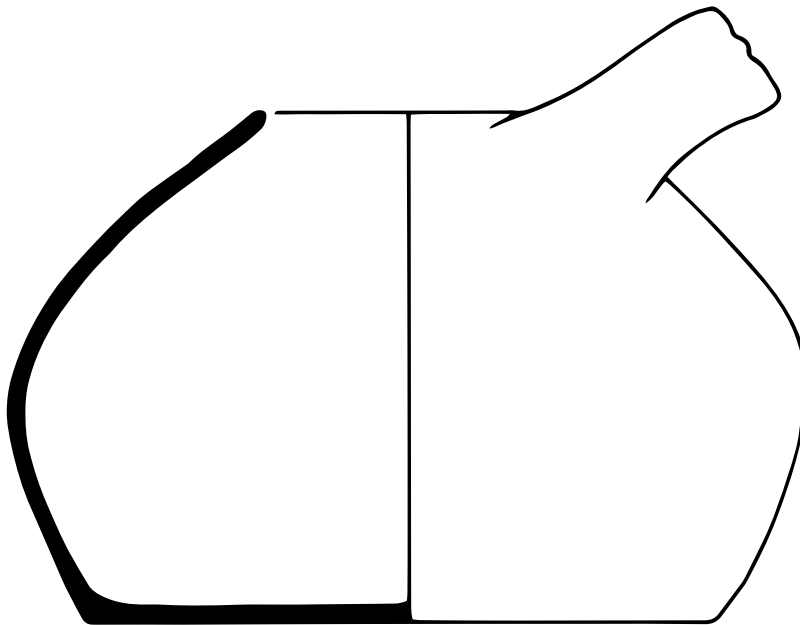

a

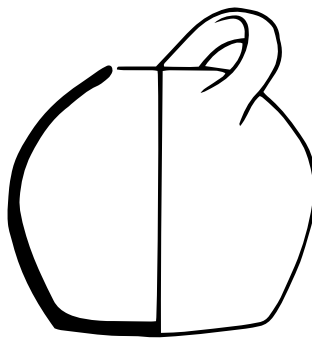

b

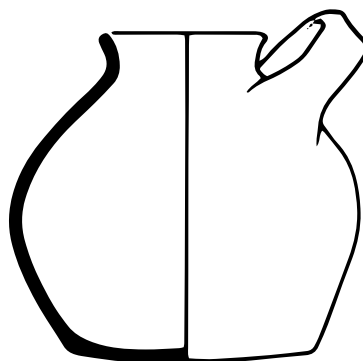

c

## 10.29 WATERING POT

**Defining characteristics:** A vessel designed to hold and sprinkle liquid rather than for pouring.

There are two main forms:

- 10.29.1 Sprinkler Watering Pot
- 10.29.2 Rose-type Watering Pot

## 10.29 WATERING POT

## Watering Pot Forms

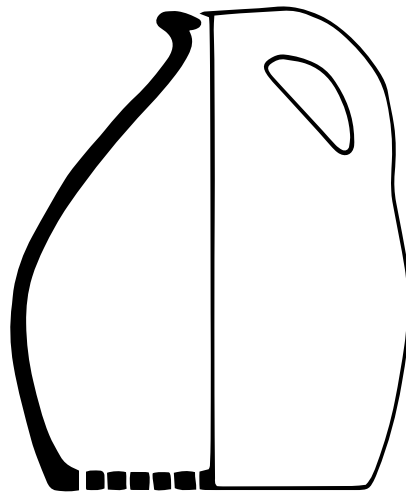

sprinkler type

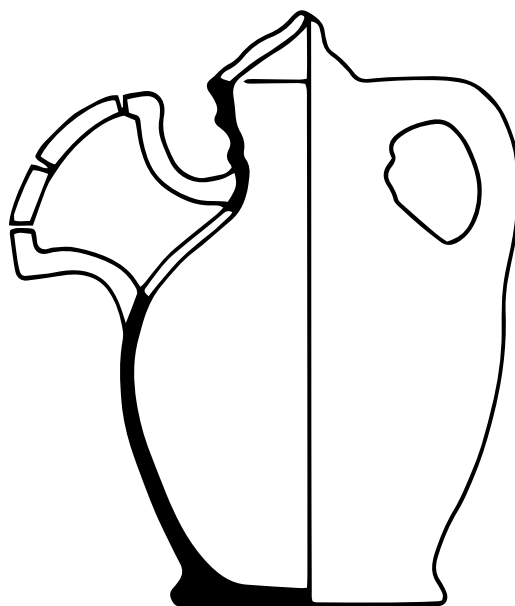

rose type

### 10.29.1 WATERING POT

#### Sprinkler Watering Pot

**Defining characteristics:** A narrow-necked JUG (with handle) or BOTTLE (without handle) with multiple holes pierced through the base. The rim encloses only a small hole to be covered by the thumb after filling, for control.

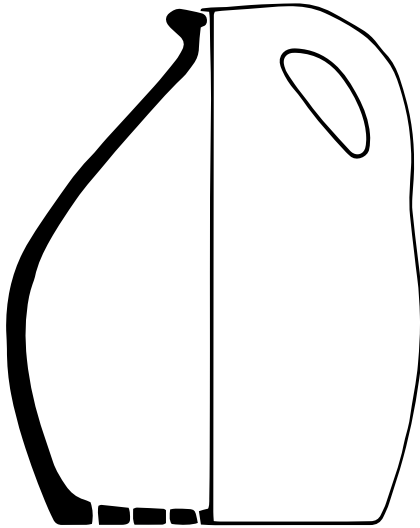

a

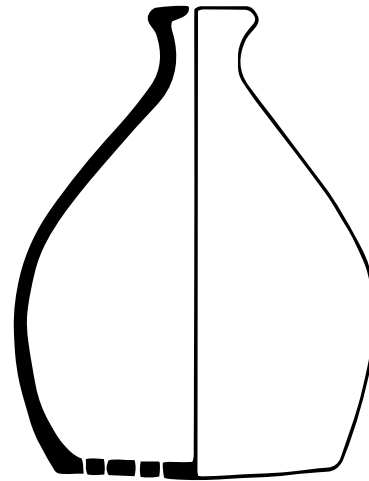

b

### 10.29.2 WATERING POT

#### Rose-type Watering Pot

**Defining characteristics:** A JUG with a rose (sprinkler) attached to the shoulder in a style similar to watering-cans in use today. There may be a strut from rim to rose, and often there is a guard over part of the rim.

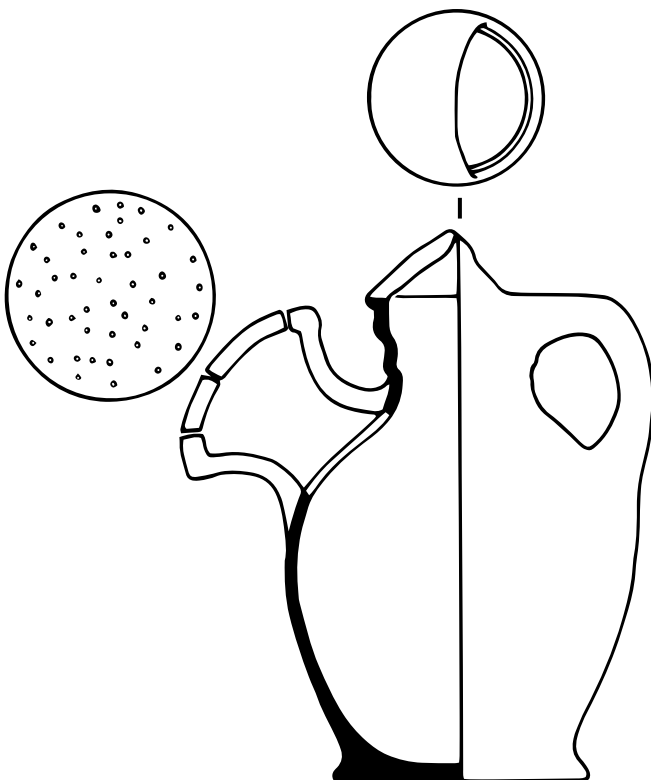

a

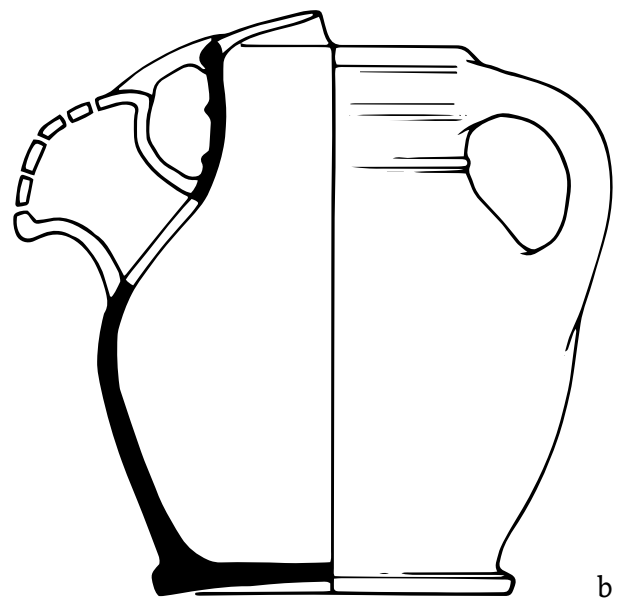

b



### 10.30 WHISTLE

**Defining characteristics:** A very small BOTTLE or JUG with a *tubular spout* which is cut or notched to form a mouthpiece or whistle. Elaborate examples are made in the form of human heads, or birds. Two types are described here.

The first is open at the top for filling with water, and when the mouthpiece/spout, which enters below the water level, is blown, it produces a warbling sound (see b, below).

The second type has one or more air-vents piercing the body, is not filled with water during use, and whistles when the mouthpiece is blown (see c and d, below).

**Alternative name:** Warbler.

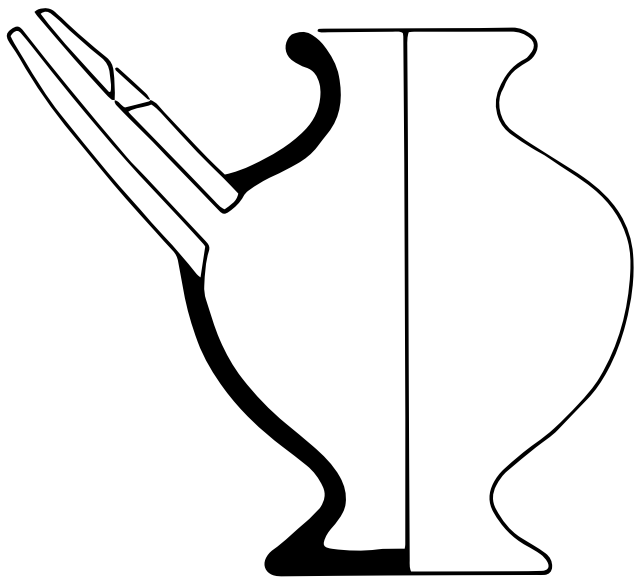

a

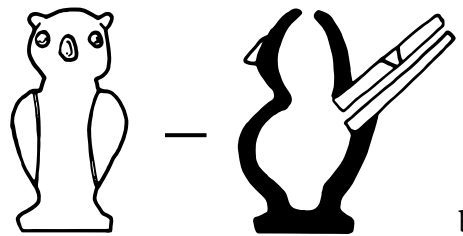

b

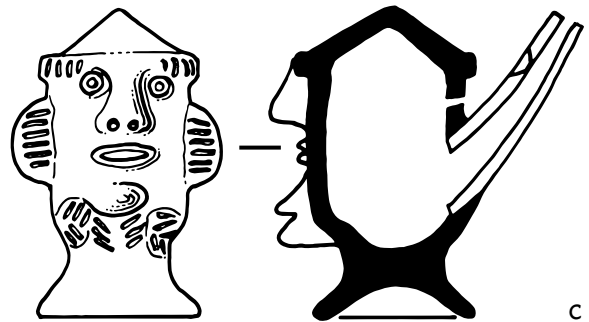

c

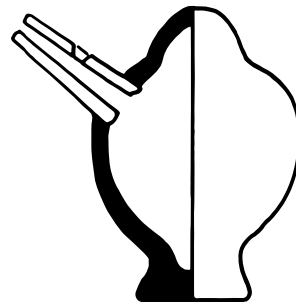

d

## SECTION 11: COMPONENT PARTS

---

### Contents

#### Introduction to COMPONENT PARTS

#### 11.1 BASES

- 11.1.1 Overall Shape
- 11.1.2 Base Angle
- 11.1.3 Embellishments

#### 11.2 BUNGHOLES

- 11.2.1 Profile
- 11.2.2 Embellishments

#### 11.3 FEET

- 11.3.1 Applied Feet
- 11.3.2 Thumbed or Pulled Feet

#### 11.4 HANDLES

- 11.4.1 Loop Handles
- 11.4.2 Straight Handles

#### 11.5 KNOBS including SUPPORTS

- 11.5.1 Type and Position
- 11.5.2 Profile or Shape
- 11.5.3 Embellishments

#### 11.6 LUGS

- 11.6.1 Angle
- 11.6.2 Method of Formation
- 11.6.3 Alignment
- 11.6.4 Shape

#### 11.7 RIMS

- 11.7.1 Angle
- 11.7.2 Form
- 11.7.3 Profile
- 11.7.4 Embellishments

#### 11.8 SPOUTS including LIPS

- 11.8.1 Applied Spouts
- 11.8.2 Pulled or Pinched Spouts

## 11.9 OTHER COMPONENT PARTS

- 11.9.1 Cut-outs or Vents
- 11.9.2 Drip Trays
- 11.9.3 Lobes
- 11.9.4 Partitions
- 11.9.5 Sockets (other than handles)
- 11.9.6 Struts

### Introduction to COMPONENT PARTS

The component parts of any ceramic vessel, for example the rim, handle and base, may also be characterised by form. The schematic representations of vessels illustrated overleaf show the different kinds of component part that are considered in this section. The potting techniques which produced these forms are not usually discussed here (but see **Section 13**) nor are they used in the definition of particular types.

**Names for component parts**

**KEY**

- 1 Lid
- 2 Rim
- 3 Spout or Lip
- 4 Handle
- 5 Neck
- 6 Shoulder
- 7 Body
- 8 Base angle
- 9 Base
- 10 Knob

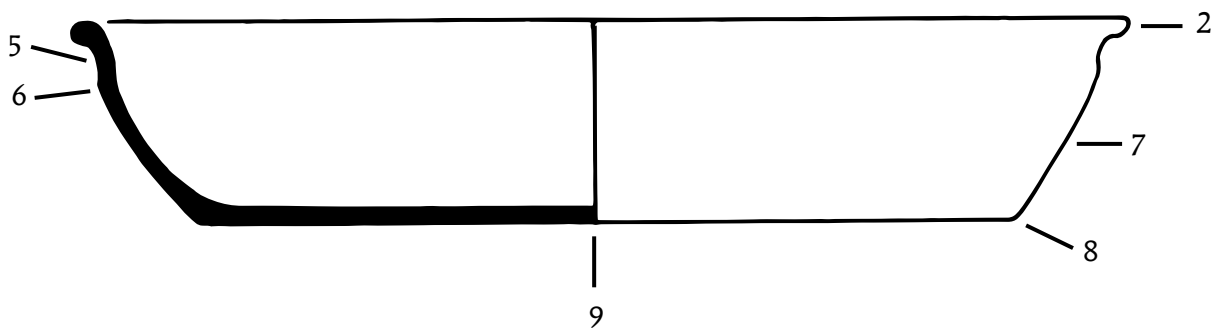
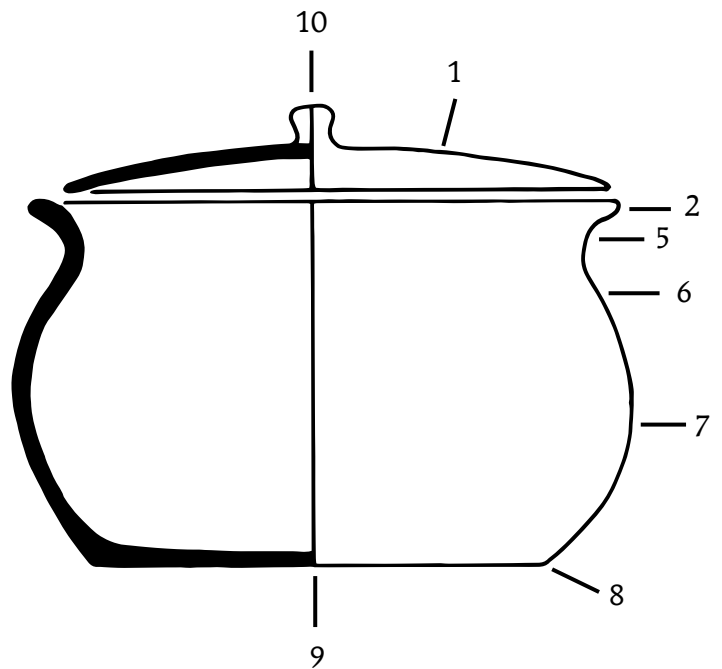
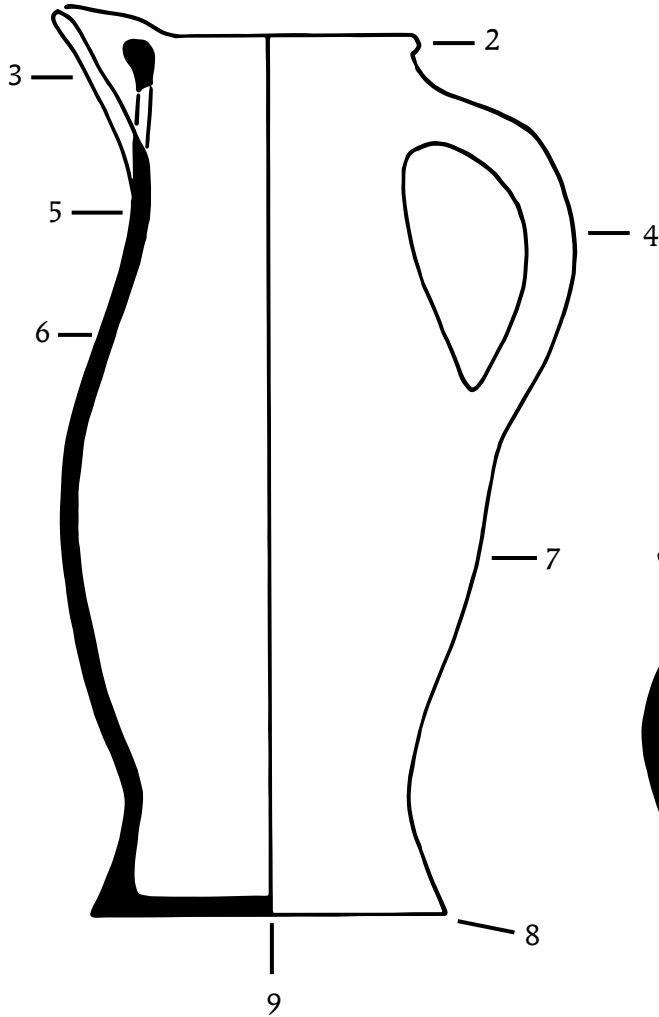

## 11.1 BASES

Bases are classified by:

- 11.1.1 Overall Shape in profile
- 11.1.2 Angle relative to the vessel wall
- 11.1.3 Embellishments to base shape

### 11.1.1 Overall Shape

of the base in profile

There are four principal types of base shape, which need no written definition, and are illustrated here alphabetically.

Concave



Flat



Rounded (no base angle)



Sagging or Convex



Less common base shapes are:  
Kicked

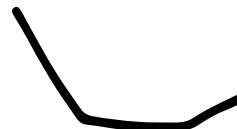

Pointed



### 11.1.2 Base Angle

The angle of the base relative to the vessel wall may be

**Acute-angled:** where the vessel wall meets the base at an angle of less than  $90^\circ$ .



**Right-angled:** where the vessel wall meets the base at approximately  $90^\circ$ .

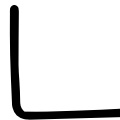

**Obtuse-angled:** where the vessel wall meets the base at an angle of more than  $90^\circ$ .

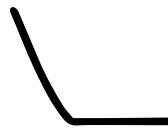

### 11.1.3 Embellishments

A wide variety of embellishments has been identified with many regional or local variants. These all affect the description of the base form. The most common types are defined here.

**Faceted:** cut around the edge, producing a polygonal shape.

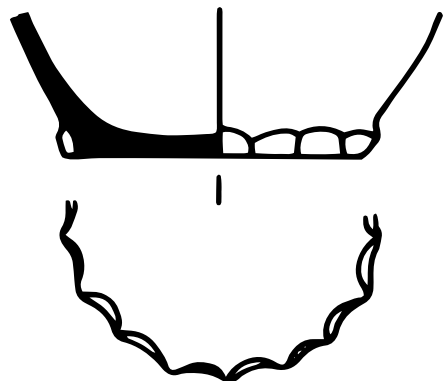

**Footring:** a band of clay around the edge of the base or on the underside, which may be created by adding clay or by turning and shaping the vessel base.



**Friiled:** with a thick, undulating footring.



### 11.1.3 Embellishments (cont.)

**Pedestal base:** a constricted column below the main body of the vessel. It may be added to the body as a separate element or formed by extending the base downwards. Its profile may be cylindrical, conical or waisted, and may be further defined as (a) **solid**, (b) **hollow** (with open base), or (c) **closed** (with closed base). Pedestal bases may function as supports, e.g. CHAFING DISHES (see 8.6) or may make it easier to grasp the vessel, e.g. LAMPS (see 8.2).

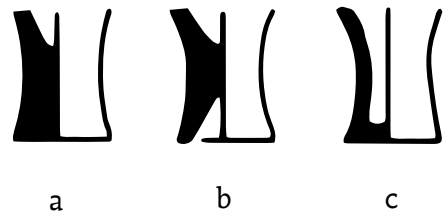

**Recessed:** created either by extending the vessel wall down or by removing clay from the underside of the base, forming a ring which is simply a continuation of the vessel wall.

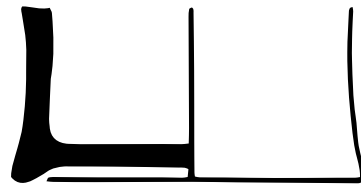

**Splayed:** thickened at the outside edge of the base.

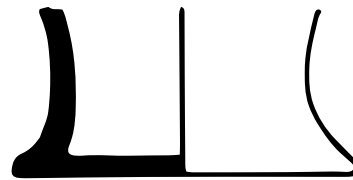

**Thumbbed:** with a series of thumb or finger impressions around the base edge, either as a continuous band or as discrete groups, and generally found on *Sagging/convex bases*. Variations should be noted.



## 11.2 BUNGHOLES

Bungholes are classified by:

- 11.2.1 Profile in section
- 11.2.2 Embellishments

### 11.2.1 Profile

in section may be

squared



rounded



### 11.2.2 Embellishments

may be

stabbed

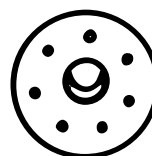

thumbbed

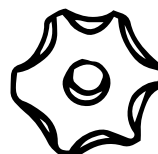

or otherwise embellished.



## 11.3 FEET

Feet are classified by **Method of Formation**:

- 11.3.1 Applied Feet
- 11.3.2 Thumbed or Pulled Feet

### 11.3.1 Applied Feet

are elements added separately to the basic vessel form and are further classified by **Profile** in section, principally:

- Circular
- Oval
- Triangular

The Profile in section may be further modified,

e.g. **clubbed, trefoil.**

Feet should be defined by length, especially within a form series for a single ware type, and very long feet may be termed **Legs**. These will have local characteristics which are not given standard definitions here.

### 11.3.2 Thumbed or Pulled Feet

are formed from the clay of the vessel itself, *thumbed* or pulled downwards from the Base Angle (c.f. Base Embellishments, 11.1.3).

## 11.4 HANDLES

Handles are classified by **Type**:

**11.4.1 Loop Handles**, attached to the pot at both ends

**11.4.2 Straight Handles**, attached to the pot at one end only.

Both types may also be embellished or decorated in a variety of ways (such as by *thumbing*) which are not classified here as the range of variation is very wide. Other component parts which may fulfil the function of handles are *Knobs* and *Lugs*, which are treated separately (see 11.5 and 11.6 respectively).

### 11.4.1 Loop Handles

are further classified by:

**Alignment**

**Position** on the vessel

**Profile** in section

and should also be described by the shape of the loop, e.g. **D-shaped** or **right-angled**. A **Ring Handle** is a specific kind where the loop is closed to form a ring (see RING-HANDLED VASE, 10.25).

**Alignment** may be either *horizontal* or *vertical* in relation to the rim.

#### Position

**Basket Handle**: spans the diameter of the rim over the top of the vessel (see BASKET-HANDLED JAR: 4.2.2). The term **basket** is preferred to **bucket** as the handle is fixed rather than movable.

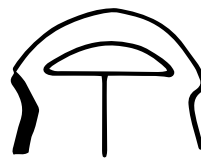

**Drop Handle**: loops downwards towards the base, usually on pedestal bowl forms such as CHAFING DISHES (see 8.6).

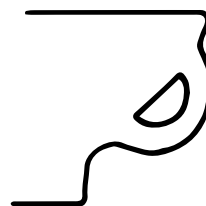

**Side Handle**: attached to the side of a vessel, it may be *vertical* or *horizontal* and may spring from rim or body.

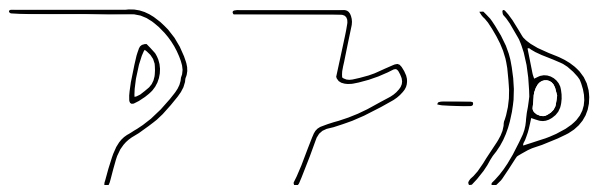

**Upstanding Handle**: attached to the rim at both ends, extending above it and running along it, but not across the diameter.

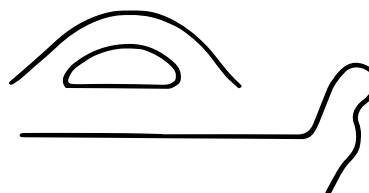

### 11.4.1 Loop Handles (cont.)

#### Profile in section

**Composite Handle:** formed by combining two or more separate elements, e.g. a strap handle inset with twisted rods.

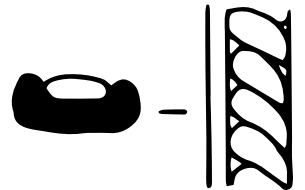

**Hollow Handle:** formed by folding or rolling a flat piece of clay into a hollow cylinder.



**Rod Handle:** solid rod of clay which in section may be circular, oval, D-shaped, square, rectangular or triangular.

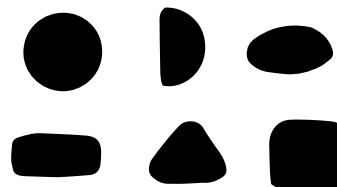

**Strap Handle:** flattened strip, with the width greater than the thickness which in section may be flat, curved, S-shaped, oval or undulating.



**Twisted Handle:** formed by twisting together two or more narrow rods of clay.



### 11.4.2 Straight Handles

are further classified by:

**Angle** of projection from the vessel

**Shape** of the handle

**Profile** in section

The **Angle** of projection from the vessel might be

**Angled:** projecting upwards from the point of attachment

**Horizontal:** projecting roughly horizontally from the vessel.

### 11.4.2 Straight Handles (cont.)

The **Shape** may be

**Hooked Handle:** curved and curling downwards at the end.

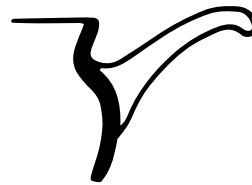

**Plain Handle:** projecting from the vessel wall in a straight line.

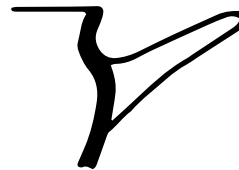

**Profile in section** should be classified as

**Rod Handle:** solid clay rod, subdivided as *loop handle* (see 11.4.1).

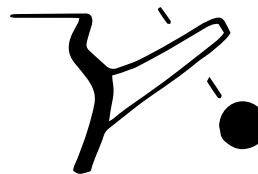

**Socketed Handle:** open at the end and partially or completely hollow. It may have acted as a socket into which a longer, solid cylinder, perhaps of wood, was inserted.



**Strap Handle:** flattened strip with the width greater than the thickness, subdivided as *loop handle* (see 11.4.1).



**Tubular Handle:** hollow cylinder of clay which does not act as a socket.



## 11.5 KNOBS including SUPPORTS

**Supports** are **Knobs** with a supporting function.

Knobs are classified by:

- 11.5.1 **Type/Position** in relation to vessel form
- 11.5.2 **Profile** in section or **Shape** in elevation
- 11.5.3 **Embellishments**

### 11.5.1 Knob Type and Position

**Lid knob:** used as a *Handle*. This term is preferred to *knop*, which is archaic.

**Rim support:** for example, in a CHAFING DISH (see 8.6) supporting another vessel above it.

### 11.5.2 Knob Profile or Shape

Both types of knob are further classified by **Profile** in section or **Shape** in elevation:

**Clubbed:** thickened at the top



**Rounded:**



**Squared:**

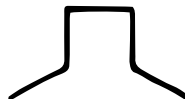

**Triangular:**



**Wedge-shaped:**



**Zoo- or Anthropomorphic:** (not illustrated) in the form of animals or human figures.

### 11.5.3 Embellishments

Knobs may also be embellished or decorated in a variety of ways (such as by thumbing) which are not classified here as the range of variation is very wide.

## 11.6 LUGS

**Defining characteristics:** A Lug is a flat piece of clay which functions either as a *handle* or as a means of suspension, e.g. on COSTRELS (see 10.7) or LAMPS (see 8.2). They may be *solid* or *pierced*.

Lugs are classified by:

- 11.6.1 Angle in relation to rim
- 11.6.2 Method of Formation
- 11.6.3 Alignment in relation to vessel wall
- 11.6.4 Shape in plan or elevation

### 11.6.1 Angle

of a Lug in relation to the rim may be:

**Horizontal**



**Vertical**



### 11.6.2 Method of Formation

may be

**Applied:** as a separate element.

**Integral:** formed from clay of the vessel itself.

### 11.6.3 Alignment

of the Lug may be

Aligned **with the vessel wall**

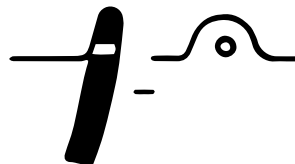

Aligned **at right angles** to the vessel wall



### 11.6.4 Shape

in plan or elevation may be

Lobed

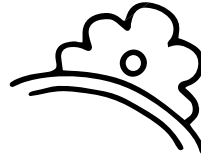

Rectangular

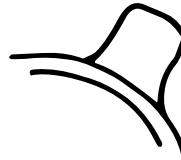

Rounded



Squared



Triangular



## 11.7 RIMS

Rims are classified by:

- 11.7.1 **Angle** in relation to the vessel wall
- 11.7.2 **Form**, best illustrated in section
- 11.7.3 **Profile** of the rim edge
- 11.7.4 **Embellishments** of the rim form

### 11.7.1 Angle

of the Rim in relation to the vessel wall

**Everted:** where the vessel wall turns outwards. A sub-division of the everted form is the **right-angled** rim, where the rim projects horizontally from the vessel wall.

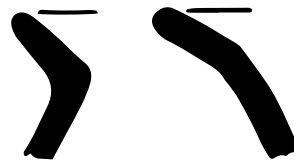

**Flat:** where there is little or no change of angle in the vessel wall, e.g. on flat forms, such as plates.



**Inturned:** where the vessel wall is turned inwards.

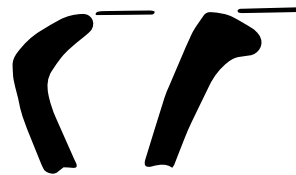

**Upright:** where the vessel walls are roughly vertical.





### 11.7.2 Rim Forms

A wide variety of rim forms have been identified and many more regional or local variants are known. Rim forms are characterised by their entire **profile in section**. The more common types are described here.

**Clubbed:** with a pronounced external thickening.



**Collared:** a collar is usually made on the outside of an upright rim by creating a broad band around the top of the rim.

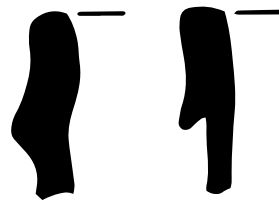

**Flanged:** a flange is formed by the division of the rim into two parts. The flange often projects horizontally from the vessel wall, either externally or internally, while the second part, the rim, projects vertically. Flanged rims have often been termed *bifid* or lid-seated rims, or galleried (a term used by modern potters).

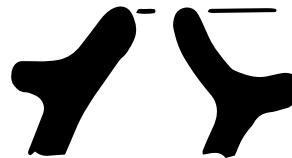

**Hammerhead:** heavily thickened both externally and internally.

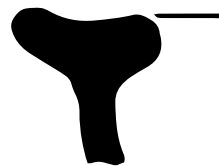

**Hooked:** curving sharply downwards into a semi-circle, commonly *everted*, particularly on bowls.

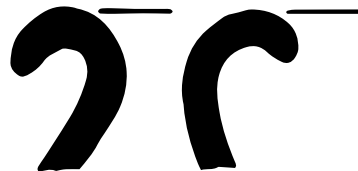

**Rolled:** formed by folding or rolling the rim edge back on itself, either externally or internally.



### 11.7.2 Rim Forms (cont.)

**Simple:** a rim of even thickness.



**Squared:** with a flat top and a vertical outer edge.

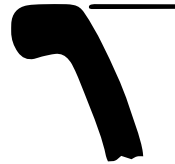

**Thickened:** a rim which swells at the edge so that it is thicker than the vessel wall at the neck. Thickening may be external or internal (or both) and is common on both open and closed forms. A rim thickened at the outer edge may also be called **beaded**.

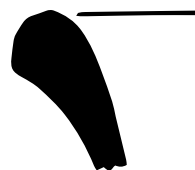

### 11.7.3 Rim Profile

Rims are also characterised by the **profile** of the rim edge. Many regional or local variants are known; some of the more common variants are described here.

**Bevelled:** where the rim top is formed at an angle. An *external* bevel is angled downwards and outwards from the top of the rim (a). An *internal* bevel is angled downwards and inwards from the top of the rim (b).

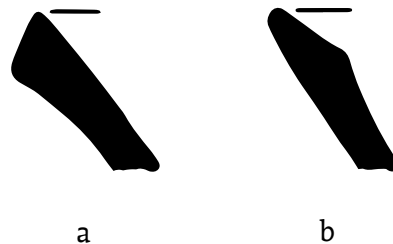

**Rounded:** with a rounded edge.



**Straight-edged:** with a vertical outer edge.



### 11.7.4 Rim Embellishments

Some common Rim Embellishments are shown. Other techniques such as cordoning are not described here.

**Crenellated:** cut around the top in a regular pattern, either squared (including stepped) or triangular, in order to produce either functional supports on the rim or a purely decorative effect.



**Ribbed:** with a regular series of horizontal grooves. This is most common on upright rims.

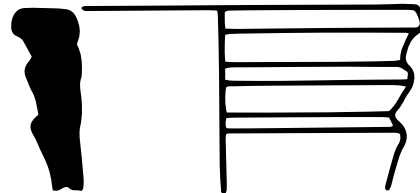

**Thumbed or thumb-impressed:** with a series of dimples created by thumbs (or fingers). These can vary in size and depth, and may be placed on the outside, top or inside of the rim, continuously or in groups. Closely-thumbed rims with the top and bottom pinched together, giving a pronounced frilly appearance, are known as **pie-crust rims (a)**.

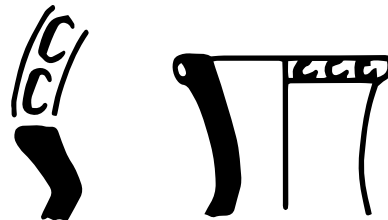

a

## 11.8 SPOUTS

Spouts are classified by **Method of Formation**:

- 11.8.1 Applied Spouts
- 11.8.2 Pulled or Pinched Spouts

### 11.8.1 Applied Spouts

An **Applied Spout** is added as a separate element to the vessel rim and should be further classified as

**Bridge Spout:** a hole is made close to the rim of the vessel (but not breaking the line of the rim itself) and clay added to form a spout. A specific type of bridge spout is the **parrot beak spout**, a form which is characteristic of, for example, the *PÉGAU* (see 3.1.16).

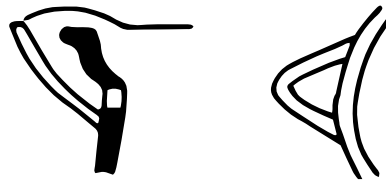

**Cut-out or Open Spout:** the vessel wall is removed at the rim and clay added to form a spout. A variant of this is the

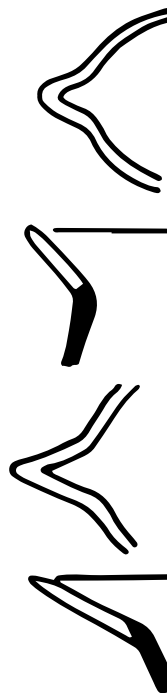

**Gutter Spout**, which is long and narrow and usually V-shaped in section.

**Attached Spout:** a hole is made in the vessel body below the neck and the spout is attached to the neck all the way up to the rim.

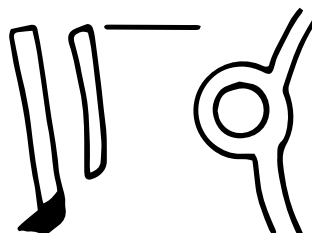

### 11.8.1 Applied Spouts (cont.)

**Tubular Spout:** a hole is made in the vessel body and a tube of clay added to form a spout. They should be further subdivided into:

(a) Freestanding

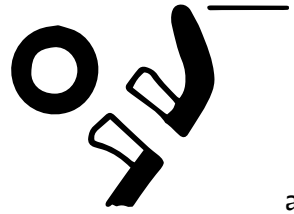

a

(b) Supported by a strut below or above

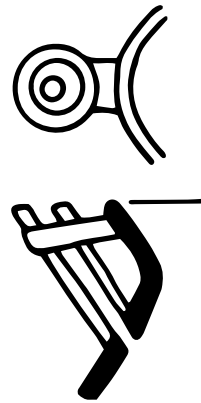

b

(c) Attached at the rim

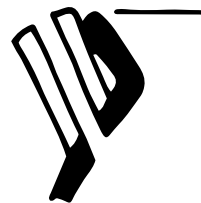

c

(d) Attached along their entire length

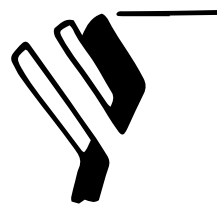

d

### 11.8.2 Pulled or Pinched Spouts

are formed from the existing rim of the vessel and are further classified by **Shape** in plan or profile as:

**Lip:** formed by pulling and/or pinching the rim slightly outward, or by slightly indenting the rim edge.



**Trefoil Spout:** an elaborate version of the lip where the whole rim has been pulled and pinched into a trefoil shape in plan.

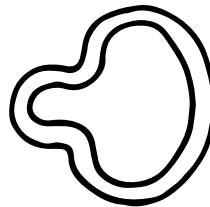

## 11.9 OTHER COMPONENT PARTS

This section includes other component parts which do not merit such detailed classification.

- 11.9.1 Cut-outs or Vents
- 11.9.2 Drip Trays
- 11.9.3 Lobes
- 11.9.4 Partitions
- 11.9.5 Sockets (other than handles)
- 11.9.6 Struts

### 11.9.1 Cut-outs or Vents

These are sections of a vessel which are completely removed before firing. They should be defined by *position* on the vessel.

**Rim:** made either at one point, perhaps to accommodate another vessel e.g. MANTLE (see 9.5) or a *spout* (see 11.8.1); or at several points. Regular cutting away around the whole rim is described as *crenellation* (see also 11.7.4, 13.2).

**Body:** singly, for example for a window in a LANTERN (see 8.3), or multiply in other vessels used for heating or lighting, to allow heat or light to escape, or air, heat or fumes to circulate, for example CHAFING DISH, FUMING POT, HEATING STAND (see 8.6, 8.7, 8.8 respectively).

**Base:** found particularly in the pedestal bases of vessel forms which are used for heating or warming e.g. CHAFING DISH (see 8.6).

Cut-outs or Vents are further defined by **shape** e.g. square, rectangular, circular.

### 11.9.2 Drip Trays

Shallow saucers to catch drips, found on CANDLESTICKS and LAMPS (see 8.1, 8.2), they have also been called Saucers. Elaborate forms may have more than one (**Secondary Drip Trays**).

### 11.9.3 Lobes

The separate elements of LOBED BOWLS, DISHES or CUPS (see 5.1.10, 5.3.3, 6.2.6), formed by folding in the vessel wall at regular intervals. The *number* of lobes should be noted.

### 11.9.4 Partitions

Vertical slabs of clay added to open vessels to divide them into units or **compartments**, e.g. DIVIDED BOWL or DISH (see 5.1.11, 5.3.4). The *number* of compartments thus created should be noted, and whether the divisions are regular or irregular.

Partitions may also be added horizontally to form **shelves** within vessels, e.g. DUTCH OVEN (see 8.10).

### 11.9.5 Sockets (other than handles)

A Socket can act as a holder, for example for a candle (see 8.1, 8.3) or for a *handle* (see SOCKETED BOWL: 5.2.2; and 11.4.2).

### 11.9.6 Struts

An element added as support for a *handle* or *spout* (see 11.8.1). Struts should be defined by **position** and by **place(s) of attachment**, e.g. on shoulder.

## SECTION 12: DECORATION

---

### Contents

- 12.1 APPLIED DECORATION
- 12.2 INCISED DECORATION
- 12.3 IMPRESSED/STAMPED DECORATION
- 12.4 PAINTED DECORATION
- 12.5 SLIPPED DECORATION
- 12.6 SGRAFFITO DECORATION

### Introduction

This section is arranged as a glossary of **decorative technique**. The use of *Glaze* (see 13.2) is not considered here, although it can be used to produce bichrome or polychrome effects.

When decoration is being described, the decorative scheme(s) should be broken down into elements which can be related to one or more decorative techniques. Any one element, or motif, may consist of a combination of two or more techniques, e.g. a thumbbed applied strip, or a stamped applied pad. Consideration should also be given to the sequence in which the decorative scheme has been created, since this can give a clue to the styles of individual workshops and even potters.

***Bold italics*** are for cross-references to terms in a different sub-section and **Plain bold** is for terms in the same sub-section.

### 12.1 APPLIED DECORATION

Applied decoration uses the addition of a clay element to the surface of a vessel. It has also been referred to as plastic decoration, although this usage is not recommended.

**Encrustation:** the application of small fragments of clay (wet or dry) or sand to create a rough surface effect.

**Figure:** A figure may be realistic or stylistic in execution and may be anthropomorphic or zoomorphic. Whole figures, or parts of figures, may form part of a relief on the body of the pot, for example KNIGHT JUGS (see 3.1.12). Other vessels may have free-standing figures or parts of figures, for example the animal figures frequently found inside the base of LOBED BOWLS (see 5.1.10) and LOBED CUPS (see 6.2.6). Other examples may utilise the body or other component of the vessel as part of the human or animal body, for example FACE JUGS (see 3.1.11), AQUAMANILES (see 10.2).

**Foil:** thin metal leaf cut into various shapes and applied to the vessel, e.g. on Tating ware.



## 12.1 APPLIED DECORATION (cont.)

**Pad:** a flat piece of clay, circular or variously shaped, which is applied to the vessel, and frequently decorated (e.g. by *Stamping*: see 12.3).

**Pellet:** a small piece of clay (but not flat – see **Pad**), irregularly-shaped or circular, which is applied to the vessel.

**Scale:** a small piece of clay, as in a **Pellet**, but applied by thumbing part of the edge on to the body of the vessel. Scales may be applied individually or in groups of various patterns, often forming part of a more complex decorative scheme.

**Strip:** a length of clay which may be broad or narrow, and of triangular, rounded or sub-rectangular section, and may be thumbbed or otherwise decorated. One strip may be twisted to form a spiral, two may be twisted together, and three or more strips may be plaited or interlaced.

## 12.2 INCISED DECORATION

This technique involves marking the surface of the pot by cutting into but not through it with a sharp instrument. Incision may be carried out on wet, leather-hard or dry clay, or even after firing.

**Combing:** the scoring of the clay body using a tool (a comb) with two or more teeth, creating a series of parallel lines across the surface of the vessel. Note that combs can also be used for **Stabbing** (see below and 13.2).

**Scratch-marking:** scoring of the clay body using a stiff brush or similar implement, creating a series of multi-directional scratches on the surface of the vessel (see 13.2, also *Brushing* in 13.2).

**Slashing:** an oblique sectioned cut made in the surface of the vessel by a sharp pointed tool. Frequently found on handles.

**Stabbing:** the piercing of the surface of a vessel with a sharp pointed tool. Variously shaped tools will produce differently shaped holes. **Combs** can also be used for stabbing (see above).

## 12.3 IMPRESSED/STAMPED DECORATION

This is made by pressing fingers, thumbs or any blunt instrument, into the body of the vessel or into applied elements. The surface is not pierced. Impressing is generally performed on pliant clay.

**Boss:** a raised part of the clay body formed by pressing the body outwards from the inside of the vessel (see also **Mould-stamping** below).

**Finger/thumb impression:** the use of finger-tip or thumb to produce an indentation in the clay body.

**Mould-stamping:** a mould is held against the wall of the vessel, which is pressed into the mould from the inside. Fingermarks on the inside of the vessel wall help to identify this technique.

**Pinching:** squeezing between fingers, on a vessel exterior (see for example *Rustication*, 13.2) or on a dish or bowl rim to give a pie-crust effect (see also 13.1; 11.7.4).

### 12.3 IMPRESSED/STAMPED DECORATION (cont.)

**Roller-stamping/rouletting:** the use of a roller-stamp or roulette wheel to produce a continuous repeated impressed pattern. Designs range from simple notches, e.g. rectangular or lozenge-shaped, to complex motifs involving more than one element. The diameter of the wheel may be calculated by noting any recurrent flaws in the design, and this may also help to identify the use of the same wheel on different vessels.

**Stamping:** a die carved with a motif in negative is pressed into the vessel surface. A wide variety of motifs were employed in stamped designs and may be found individually or in combination. Stamps may be impressed directly on to the clay body, or pressed into additional elements and applied to the vessel, e.g. *Pads* (see 12.1; see also **Mould-stamping** above). The occurrence of the same stamped motif on different pots can identify the same die and thus the products of one potter or one workshop.

**Thumbing:** see **Finger/thumb impression** above.

### 12.4 PAINTED DECORATION

This term is used for decoration made with liquid pigment, and should not be used to describe the application of *Slip* (see 12.5). Pigment may be applied in one or more colours (e.g. Saintonge polychrome decoration).

### 12.5 SLIPPED DECORATION

This term covers all decoration made using *Slip* – a suspension of fine clay in water (see also 13.2).

Slipped decoration can be in one or more colours which generally contrast with the clay body of the vessel. The description of this type of decoration should consider the following:

**method of application**, which varies with the consistency of the slip used; thicker consistencies may be *trailed*, *poured* or *squeezed* in lines or dots; thinner consistencies may be applied with a *brush* or other implement; or the vessel may be *dipped* in the slip

the **colours** used

the **decorative scheme** represented, which may be overall, e.g. **Marbling** (see 13.2) or may consist of individual motifs.

### 12.6 SGRAFFITO DECORATION

This technique is used on vessels which have been coated with a *Slip* of contrasting colour (for *Slip*, see 12.5 and 13.2). A design is cut through the overlying slip, exposing the contrasting colour of the clay body beneath.

**Double-slipped sgraffito:** found on vessels which have been coated with two contrasting layers of slip, where the design is cut through the upper layer of slip to reveal the underlying slip coating.

**Wet sgraffito:** a design created by dragging the fingers or *Combing* through the slip while still wet, to reveal the colour of the underlying vessel.

## SECTION 13: MANUFACTURE AND SURFACE TREATMENT

---

### Contents

#### 13.1 CLAY PREPARATION AND FORMING

#### 13.2 SURFACE MODIFICATION

#### 13.3 FIRING OF VESSELS

#### 13.4 POST-FIRING MODIFICATION AND EVIDENCE OF USE

### Introduction

This section presents a glossary of terms used to describe aspects of the manufacture and subsequent treatment of pottery before and during use.

***Bold italics*** are for cross-references to terms from a different sub-section. **Plain bold** is for terms in the same sub-section.

#### 13.1 CLAY PREPARATION AND FORMING

These terms describe the preparation of raw materials and the primary forming of the vessel, i.e. the creation of the basic shape.

**Clay:** the raw material used by potters. Particular types of clay may be used for particular wares, e.g. for *stoneware* (see 13.3).

**Coil-building:** a method of **Handforming** a vessel by joining a series of coils or ‘sausages’ of clay, either as separate rings or as a continuous spiral. The coils are then smoothed out but may still be visible as corrugations on the interior of the vessel.

**Core:** the centre of the section through the vessel wall, frequently differentiated in colour from the **Margins** and/or **Surfaces**.

**Cracking:** a fault resulting from stresses created during forming and drying. Causes include rapid firing, rapid cooling, and the application of glaze, decoration or component parts to over-dried but unfired pots.

**Drawing:** see **Pinching**.

**Fabric:** the **Clay** from which a vessel is made. This also encompasses any non-plastic elements within the clay (see **Inclusion** and **Temper**).

**Fillet:** an extra piece of clay added to strengthen a vessel, generally at a vulnerable point such as the base angle, or at the base of a handle or spout.

**Grog:** a type of **Inclusion** (see below) consisting of ground-up fired clay or pot sherd added deliberately to the clay fabric as a **Temper**. Usage to describe *any* added inclusion is not recommended.

## 13.1 CLAY PREPARATION AND FORMING (cont.)

**Handforming:** the manufacture of a vessel without the use of a **Wheel**. This encompasses the techniques of **Slab-building**, **Pinching** and **Coil-building**.

**Inclusion:** a non-plastic element included naturally in **Clay**, or added deliberately or accidentally during the manufacturing process. Inclusions can be divided into:

accidental impurities which occur naturally in the clay, such as decomposed fragments of the underlying bedrock; and

inclusions deliberately added by the potter in order to strengthen the clay and make it more workable. These are generally called **Temper** (other terms include filler, additive, opening material, aggregate, modifier, binder – none of which are recommended). The term **grog** is used by modern potters as a general term for added inclusions (but see **Grog** above for recommended usage here).

**Leather-hard:** the state of a vessel during the first stage of drying, in which the clay has lost its original plastic properties and behaves as a solid. It will break rather than distort, but may still be cut.

**Levigation:** a method of clay preparation that removes by water separation all coarse components, leaving only the finest clay fraction. This results in a particularly fine-grained **Clay**.

**Luting:** the joining of one piece of clay to another by using a thick **Slip** or **Slurry** (see 13.2) as a joining medium, for example, for the application of handles.

**Margin:** the section of a vessel wall between the **Core** and the **Surfaces**, often different in colour from one or both.

**Mortising:** see **Riveting**.

**Mould:** a rigid form over or into which clay is pressed or poured to form objects of the same shape.

**Pinching or drawing:** a method of **Handforming** small, simple vessel forms by hollowing out a ball of clay and progressively pinching up the vessel walls between finger and thumb (see also 12.3).

**Riveting or Mortising:** the joining of two elements of a vessel by the insertion of a protruding piece of clay through a hole in one piece, often used for the addition of handles and feet and so forth.

**Slab-building:** a method of **Handforming** a vessel by joining sheets or slabs of clay together. This technique is frequently used for rectangular vessels, e.g. DRIPPING DISH (see 5.3.6).

**Slip-casting:** a method of manufacture where a thin suspension of **Clay** in water is poured into a prepared **Mould** and allowed to dry. This process was not used in Britain until the later post-medieval period.

**String marks:** see **Wire marks**.

**Surface:** the internal and external skin of a vessel wall, often different in colour from the **Margins** and/or **Core**.

### 13.1 CLAY PREPARATION AND FORMING (cont.)

**Temper:** **Inclusions** added deliberately to the **Clay** by the potter in order to strengthen the fabric, to make it more workable, and to reduce the risk of thermal shock during firing and subsequent use. The common tempers in Britain include crushed flint, sand, crushed chalk or limestone and **Grog**. The term may also be used to describe the action of adding such inclusions.

**Template:** a tool cut to a shape which is used to produce a constant feature of the vessel. Generally used on wheelthrown vessels, it may be made from a wide variety of materials.

**Throwing:** the manufacture of a vessel on a **Wheel** rotated at sufficient speed to allow the potter to use centrifugal force to shape the vessel. Characteristic traces left by wheelthrowing are **Throwing Rings** and **Wire Marks**.

**Throwing Rings:** apparently concentric rings, forming a spiral seen on the interior of a vessel. These are characteristic marks formed during wheelthrowing and may be used to distinguish left- or right-handed potters, or the direction of rotation of the wheel.

**Turntable:** a flat support used when forming a vessel, which permits rotary motion but which may not be centrally pivoted and which does not supply centrifugal force.

**Wedging:** the process of mixing the **Clay** to create an even-textured medium for vessel forming.

**Wheel:** a centrally-pivoted support used when forming a vessel, which may be rotated at sufficient speed to produce centrifugal force.

**Wire marks:** characteristic markings seen on the underside of a wheelthrown vessel, consisting of concentric loops, parallel or radiating lines, left by the cutting of the pot from the **Wheel**.

## 13.2 SURFACE MODIFICATION

These terms describe the processes of surface modification which take place after forming and before firing.

**Alkaline glaze:** a type of **Glaze** composed of alkaline compounds, e.g. sodium or potassium.

**Ash glaze:** a type of **Glaze** in which the **Flux** is ash. It is not applied to the pot but during firing, when hot ash from the fire impinges on unglazed surfaces, it acts as a **Flux**.

**Bib glaze:** a patch of **Glaze** applied to a specific part of the vessel, usually below the spout or opposite the handle.

**Blade Trimming:** see **Trimming**.

**Brushing:** the **Texturing** of a vessel surface with an implement composed of stiff bristles, or with vegetable matter such as twigs.

**Burnishing:** the rubbing of a *Leather-hard* vessel surface with a smooth, hard implement, to produce a polished surface.

**Combing:** the **Texturing** of a vessel surface with a toothed or serrated tool (for decorative effects, see 12.2).

**Crawling:** a common **Glaze** fault, where the glaze recedes to reveal the fabric beneath.

**Crazing:** a **Glaze** fault, where small cracks in a fired glaze may occur during post-firing cooling or subsequent use.

**Crenellation:** the cutting of the rim of a vessel in a repeated pattern, either squared or pointed. The design can be either functional, for example in CHAFING DISHES to form a RIM SUPPORT (see 8.6; 11.5) or purely decorative (see also 11.7.4).

**Cut-out or vent:** before firing, a section is completely removed from the vessel body with a sharp implement. They are usually primarily functional, to allow light or heat to escape, e.g. CHAFING DISH (8.6), LANTERN (8.3), but occur in a variety of shapes, some obviously decorative (see also 11.9.1).

**Encrustation:** the application of small fragments of clay (wet or dry) or sand to create a rough surface effect.

**Engobe:** an archaic term (now not recommended) for a coating of **Slip**, added to a vessel as decoration, or in order to conceal the clay beneath.

**Fettling:** see **Trimming**.

**Fingering:** see **Thumbing**.

**Flux:** a substance which when added to a **Glaze** lowers the melting point of the silica, e.g. lead, tin or ash.

**Frit:** silica and a **Flux** melted together, cooled and ground into a powder before application as a **Glaze** mixture.

## 13.2 SURFACE MODIFICATION (cont.)

**Galena:** see **Lead Glaze**.

**Glaze:** a glassy coating on the surface of a vessel, formed by the melting of silica. The addition of a **Flux** results in a lower melting point. Glaze may be applied to the vessel by dipping, pouring, splashing or painting, and may be described by the method used, e.g. **Splash Glaze**, **Suspension Glaze**. Glaze may be classified by the principal flux used, e.g. **Ash Glaze**, **Lead Glaze**; or by added colorants or opacifiers, e.g. in **Tin Glaze**. It can also be defined by the position of the glaze, e.g. **Bib Glaze**.

**Knife-trimming:** see **Trimming**.

**Lathe-turning:** **Trimming** done on a lathe, often using a *template*.

**Lead glaze:** a **Glaze** achieved by the application of powdered lead oxide (**Litharge**) or lead sulphide (**Galena**) to the surface of the vessel. These substances are toxic, so lead glazes are often applied as **Frit**.

**Litharge:** see **Lead Glaze**.

**Lustre:** a thin metallic film fused on to a previously fired **Glaze** in a subsequent, lower temperature firing. Different metals produce different colours (e.g. copper gives coppery red).

**Marbling:** the partial mixing of two or more **Slip** colours on the surface of a vessel.

**Piercing:** the complete penetration of the vessel wall, performed before firing (n.b. *Perforation* is performed *after* firing – see 13.4 below).

**Rustication:** the **Texturing** of the exterior surface of a vessel by, for example, finger-pinching, fingertip or fingernail impression (see also **Thumbing**).

**Salt glaze:** a **Glaze** achieved by volatilising common salt inside the kiln during firing. This sometimes results in a texture which is compared to orange peel. This process is only possible on **Stonewares**, requiring a temperature of above 1100°C.

**Scoring:** see **Scratch-marking**.

**Scratch-marking** or **Scoring:** the **Texturing** of a *Leather-hard* vessel exterior by brushing or scratching in different directions, often to improve adhesion of added elements such as a handle (see also *Incised Decoration*, 12.2).

**Self-slip:** a finely-textured surface which appears to be slipped with the same material as the clay body, but which results from careful wiping of the surface with a wet hand.

**Slip:** *Clay* mixed with water to a smooth consistency. May be applied to a vessel by dipping, pouring, painting, trailing or brushing and wiping. Very thick slip is also called **Slurry** (see also *Slip Decoration* 12.5).

**Slurry:** see **Slip**.

**Smoothing:** making even a vessel surface by the removal of protrusions or imperfections, using a soft, yielding tool such as cloth, wool, the hand or vegetable matter.

## 13.2 SURFACE MODIFICATION (cont.)

**Splash glaze:** an effect created by splashing liquid or dusting powder onto the vessel surface in an erratic and partial coverage which takes the form of spots, splashes or runs.

**Surface treatment:** the modification of the surface of a vessel before firing. This may include such processes as **Burnishing, Glazing, Scratch-marking, Smoothing** and **Trimming**.

**Suspension glaze:** a **Glaze** applied in liquid form.

**Texturing:** the deliberate roughening of a vessel surface. This may be in order to provide a key for the addition of Component Parts (see Section 11) or to permit a better grip. Different types of texturing include **Brushing, Combing, Rustication, Scratch-marking** and **Scoring**.

**Thumbing:** the use of thumb or finger impressions in either a functional or a decorative scheme. Functional thumbing includes the securing of additional elements to a vessel, e.g. handle(s), and continuous thumbing or discreet thumbing at regular intervals, either to create “feet” to stabilise a convex base or to minimise contact between a vessel in the kiln stack, to reduce losses (see also 11.1.3, 11.3.2, 11.7.4, 12.3).

**Tin glaze:** a white and opaque **Glaze** produced by the addition of tin oxide to opacify **Lead Glaze**.

**Trimming:** the removal of excess clay and imperfections from vessel walls and bases when in a *Leather-hard* state, by trimming with a sharp tool. This process may be more specifically referred to as **Knife Trimming** or **Blade Trimming**, or when done on a wheel, it should be called **Turning**. A more specific form of turning is **Lathe-turning**. The term **Fettling** is not recommended.

**Turning:** see **Trimming**.

**Vent:** see **Cut-out**.

**Wash:** a very thin **Slip** or liquid pigment which is applied to the surface of the vessel.



### 13.3 FIRING OF VESSELS

These are terms relating to the firing of a vessel.

**Biscuit firing:** the first firing stage, where vessels are fired twice, once before glazing and once after. The term *bisque* is not recommended.

**Bloating:** A fault caused by **Overfiring**, or by the burning-out of impurities from within the body, resulting in a spongy texture and blister-like areas on the vessel surface caused by the expansion of large gas bubbles.

**Blow-out or Spit-out:** a fault caused during firing where portions of the vessel surface, or added elements, are blown away by the build up of steam within the clay body. This can occur because of poor *Wedging* of the clay (see 13.1), insufficient drying before firing or over-rapid cooling after firing, but is generally caused by the rapid expansion of impurities in the clay during firing.

**Bonfire or Open firing:** a means of firing in a temporary, open construction in which vessels laid on a bed of fuel are covered by more fuel. Firing is complete when the fuel has burnt itself out. This type of firing allows little or no temperature control, and faults (e.g. **Cracking**, **Dunting**) are common. The lack of control over the firing atmosphere means that vessels are generally subject to **Oxidisation**.

**Clamp kiln or Pit kiln:** a means of firing pottery which is intermediate between **Bonfire or Open firing** and **Kiln firing**. The vessels are stacked together with the fuel in a shallow pit, and then covered with more fuel and a temporary covering such as stones or turfs and fired.

**Cracking:** see **Dunting** and 13.1.

**Downdraught Kiln:** a **Kiln** in which hot gases from the fuel leave the **Fire-box(es)** at the edge of the kiln, travel to the roof of the kiln, and are then caused by the kiln's draughting system to go down through the pots and out through the **Flues** in the kiln floor.

**Dunting:** a fault resulting from over-rapid cooling after firing, causing stresses as constituents within the vessel contract at different rates. Vertical cracks appear in the rim of a vessel, or, in the body, a series of concentric horizontal cracks linked by vertical cracks (see also **Cracking**)

**Earthenware:** *Fabric* fired to a sufficient temperature to give strength but too low to vitrify, the clay remaining porous.

**Fire-bar:** an item of **Kiln furniture** acting as a support for vessels within the **Kiln**.

**Fire-box:** the combustion chamber of a **Kiln**, (usually one fired by wood).

**Fire-chamber:** the interior of the **Kiln** in which the vessels are stacked.

**Fire-clouding:** the localised variation in colour over a vessel surface, resulting from the contact of vessel and fuel during firing; also called **Flash-marks**.

**Flue** (also known as the stoke-pit arch): a channel for conveying flames and heat into the **Kiln**.

### 13.3 FIRING OF VESSELS (cont.)

**Kiln:** a means of firing pottery in a closed construction consisting of a **Fire-box** and a chamber in which the vessels are separated from the fuel (see also **Clamp Kiln**). The admission of oxygen may be regulated to enable **Oxidisation** or **Reduction** of a vessel with better control of firing. The vessels may be stacked within the kiln using **Kiln Furniture**. Kilns are classified by the arrangement of firebox and firing chamber into **Updraught** and **Downdraught kilns**.

**Kiln Furniture:** items usually made of fired clay, used as aids in the stacking of vessels within the **Kiln**. The range of forms is extensive, but the types most commonly encountered are **Fire-bars**, **Props**, **Saggars**, **Spacers** and **Trivets**.

**Open Firing:** see **Bonfire**.

**Overfiring:** firing vessels at too high a temperature or for too long, resulting in faults such as melting, **Warping** or **Bloating**.

**Oxidisation:** the process by which oxygen is admitted to the firing atmosphere in the **Kiln** or **Bonfire**, resulting in the production of orange to red, or white fabrics.

**Pit kiln:** see **Clamp Kiln**.

**Prop:** an item of **Kiln Furniture** which supports a vessel within the kiln, usually found in a kiln with no **Fire Bars** or raised floor.

**Reduction:** the process by which oxygen is excluded from the firing atmosphere in the **Kiln**, resulting in the production of grey to black fabrics or surfaces.

**Saggar:** an item of **Kiln Furniture** in the form of a clay container in which glazed vessels (often smaller and more delicate) are placed within the kiln, to protect them during firing.

**Second:** a vessel distorted or damaged during firing, but still usable; not as badly damaged as a **Waster**. It may also be known as a semi-waster.

**Spacer:** an item of **Kiln Furniture** used for spacing or separating vessels within the **Kiln**. A spacer may be a re-used potsherd or tile, or a small lump or wedge of clay.

**Spalling:** the disintegration of the vessel surface, resulting from the decomposition of calcium carbonate after firing, from expansion of gas or air or from over-rapid heating during firing. Lens-like portions of the surface become detached (spall) and flake off.

**Spit-out:** see **Blow-out**

**Stacking scar** or **Stacking ring:** mark(s) resulting from the direct contact of vessels during a firing, leaving 'shadows' on adjacent vessels, sometimes causing the fusing together of vessels by glaze.

**Stoneware:** a particular clay fired to a temperature between 1200°C and 1350°C, resulting in partial or complete vitrification of the fabric, and therefore a great degree of impermeability.

**Trivet:** an item of **Kiln Furniture**, comprising a small three-footed support, generally with points or spurs, used to separate vessels during firing.

### 13.3 FIRING OF VESSELS (cont.)

**Underfiring:** the firing of vessels either for an insufficient time or at an insufficiently high temperature, resulting in a soft, friable fabric with flaky surfaces.

**Updraught kiln:** a simple enclosed firing chamber in which the heat moves upwards from below the pots.

**Warping:** the distortion of a vessel caused by overfiring; most likely to occur with high-fired wares.

**Waster:** a vessel so badly distorted or damaged during firing that it cannot be used. Less badly damaged vessels may be described as **Seconds**. Fragments of wasted vessels are also called wasters.

## 13.4 POST-FIRING MODIFICATION AND EVIDENCE OF USE

**Terms relating to the post-firing modification or use of a vessel.**

**Limescale:** a calcareous **Residue** found on the interior surface of a vessel used for boiling or storing water, and also in chamber-pots.

**Perforation:** the penetration of the vessel wall after firing, for example, the re-use of JARS as braziers or LANTERNS (pre-firing penetration of the vessel wall is known as *Piercing* – see 13.2).

**Repair:** any attempt to mend cracks or breakages in a vessel, for example by riveting or by plugging.

**Residue:** a deposit left on the surface of a vessel as a result of use, e.g. food remains, or **Limescale**.

**Sooting:** a layer of carbon deposited on the surface of a vessel, from use over an open fire. It may result from two processes:

**smoke blackening;** carbon deposited by contact with a wood or coal fire, or sooting carried over the surface of a vessel by a flame. It may occur on either the exterior of the vessel or the interior (e.g. through use as a Brazier) and may vary in density.

**charcoal sooting** from contact with a fire, which produces heat without a flame. The sooting is confined to the part of the vessel in direct contact with the charcoal.

**Wear marks:** abrasion of a vessel following use, for example:

**Scars** on the interior surface from the mixing of ingredients;

**Rubbing Scars** around the rim of a vessel from the presence of a lid;

**Suspension Marks** from the suspension of a vessel (for example by cord or thong, or by chains over a fire);

on the base of a jug beneath the lip, from constant tipping to pour.

## SECTION 14: BIBLIOGRAPHY

---

- Alexander, J.J.G., 1970 *The Master of Mary of Burgundy, a Book of Hours for Engelbert of Nassau: The Bodleian Library*, Oxford, London
- Bayley, J., 1992 'Metalworking ceramics', *Medieval Ceramics* **16**, 3-10
- Bloice, B.J. and Dawson, G.J., 1971 'Classification of shapes' in Bloice, B.J., 'Norfolk House, Lambeth: excavations at a Delftware kiln site, 1968', *Post-Med Archaeol* **5**, 99-159
- Brooks, C.M., 1983 'Aspects of the sugar-refining industry from the 16th to the 19th century', *Post-Med Archaeol* **17**, 1-14
- Brown, D.H., 1995 'Iberian pottery excavated in medieval Southampton' in Gerrard *et al.* (eds.) 1995, 319-28
- Bruce-Mitford, R., 1997 'Pottery' in Bruce-Mitford, R. *Mawgan Porth*, English Heritage, London, 71-80
- Cotter, J.P., 1992 "'The mystery of the Hessian Wares". Post-medieval triangular crucibles' in Gaimster and Redknap (eds.) 1992, 256-72
- Currie, C.K., 1993 'The archaeology of the flower pot in England and Wales, circa 1650-1950', *Garden Hist* **21.2**, 227-46
- Dunning, G.C., 1964 'Barrel-shaped and cylindrical costrels on the Continent and in England' in Cunliffe, B., *Winchester Excavations 1949-1960, Vol. 1*, 127-36
- Dunning, G.C., 1969 'Medieval church cruets in pottery', *Medieval Archaeol* **13**, 226-7
- Evans, K.J., 1969 'A discovery of two unusual objects in New Shoreham', *Sussex Archaeol Coll* **107**, 80-4
- Freke, D.J., 1979 'The excavation of a 16th-century pottery kiln at Lower Parrock, Hartfield, East Sussex, 1977', *Post-Med Archaeol* **13**, 79-125
- Gaimster, D.R.M. and Verhaeghe, F., 1992 'Handles with face-masks: a cross-Channel type of late medieval highly decorated basin' in Gaimster and Redknap (eds.) 1992, 302-23
- Gaimster, D.R.M. and Redknap, M. (eds.) 1992 *Everyday and Exotic Pottery from Europe*, Oxbow, Oxford
- Gerrard, C.M., Gutierrez, A. and Vince, A.G. (eds.), 1995 *Spanish Medieval Ceramics in Spain and the British Isles*, Brit Archaeol Rep **S610**, Oxford
- Goggin, J.M., 1960 *The Spanish Olive-Jar: an Introductory Study*, Yale Univ Publications in Anthropology **42**
- Hurst, J.G., 1966 'Imported flasks' in Bellamy, C.V., 'Kirkstall Abbey excavations, 1960-4', *Pub Thoresby Soc* **51**, 54-9
- Hurst, J.G., 1976 'The Pottery' in Wilson, D.M. (ed.), *The Archaeology of Anglo-Saxon England*, 283-348

- Hurst, J.G., Neal, D.S. and van Beuningen, H.J.E., 1986 *Pottery Produced and Traded in North-West Europe 1350-1650*, Rotterdam Papers VI
- Hutchinson, G., 1979 'The bar-lug pottery of Cornwall', *Cornish Archaeol* **18**, 81-103
- Janssen, H., 1983 'Later medieval pottery production in the Netherlands' in Davey, P. and Hodges, R., *Ceramics and Trade*, Sheffield, 121-85
- Jennings, S., 1992 'A ceramic fish trap' in Gaimster and Redknap (eds.) 1992, 66-9
- Le Patourel, J., 1992 'Ceramic horns' in Gaimster and Redknap (eds.) 1992, 157-66
- Lewis, J.M., 1968 'Medieval church cruets in pottery', *Medieval Archaeol* **12**, 147-9
- McCarthy, M.R. and Brooks, C.M., 1988 *Medieval Pottery in Britain AD 900-1600*, Leicester University Press
- Moorhouse, S., 1972 'Medieval distilling apparatus of glass and pottery', *Medieval Archaeol* **16**, 79-121
- Moorhouse, S., 1984 'Late medieval pottery plant-holders from eastern Yorkshire', *Medieval Archaeol* **28**, 194-202
- Orton, C.R., 1980 *Mathematics in Archaeology*, Cambridge University Press
- Peacock, D.P.S. and Williams, D.F., 1986 *Amphorae and the Roman economy*, Longman, London
- Pearce, J., 1992 *Border Wares*, H.M.S.O., London
- Platt, C. and Coleman-Smith, R., 1975, *Excavations in Medieval Southampton 1953-1969*, Leicester University Press
- Sell, S.H., 1984 'The medieval incurved dish - a topic for discussion', *Medieval and Later Pottery in Wales* **7**, 53-60
- Stephenson, R., 1991 'Post-medieval ceramic bird pots from excavations in Greater London', *London Archaeologist* **6:12**, 320-1
- Thomas, C., 1959 'Imported pottery in Dark Age western Britain', *Medieval Archaeol* **3**, 89-111
- Verhaeghe, F., 1991 'An aquamanile and some thoughts about ceramic competition with quality metal goods in the Middle Ages' in Lewis, E. (ed.), *Custom and Ceramics*, APE, Wickham, 25-61
- Verhaeghe, F., 1992 'Light in the darkness: a ceramic lantern' in Gaimster and Redknap (eds.) 1992, 167-76
- Webster, G. (ed.), 1976 *Romano British pottery: A Student's Guide*, Counc Brit Archaeol Res Rep 6, 3rd ed.
- White, A.J., 1984 'Medieval fisheries in the Witham and its tributaries', *Lincolnshire Hist Archaeol* **19**, 29-35

## APPENDIX I: FURTHER CLASSIFICATION OF PROFILES: AN EXAMPLE

---

### Classification of jar profiles

Classifications are capable of almost endless subdivisions and this is particularly true of any handmade product such as pottery vessels. This appendix is solely an exercise to see how far classification of a ceramic form could be taken. This approach is not recommended for the everyday recording of pottery, but is included partly to show the kind of attributes that can be selected if a greater degree of classification is thought desirable for a local form, a regional tradition, or changes through time.

What is presented here is one approach to the further classification of a particular and common form, **JAR**. The hierarchy of defining characteristics used in this example is shown on the next two pages, with the principal characteristic, in this case profile, at the top. The further subdivisions of that characteristic are listed underneath, and size is included as a characteristic. The drawings on the second page are of actual vessels at an approximate scale of 1:8 and illustrate the text on the first page.

This approach is capable of endless variety, and its results dependent on both the selection and the ordering of the characteristics. A coding system could also be introduced which identified the order of the attributes selected.

APPENDIX I

Classification of jar profiles

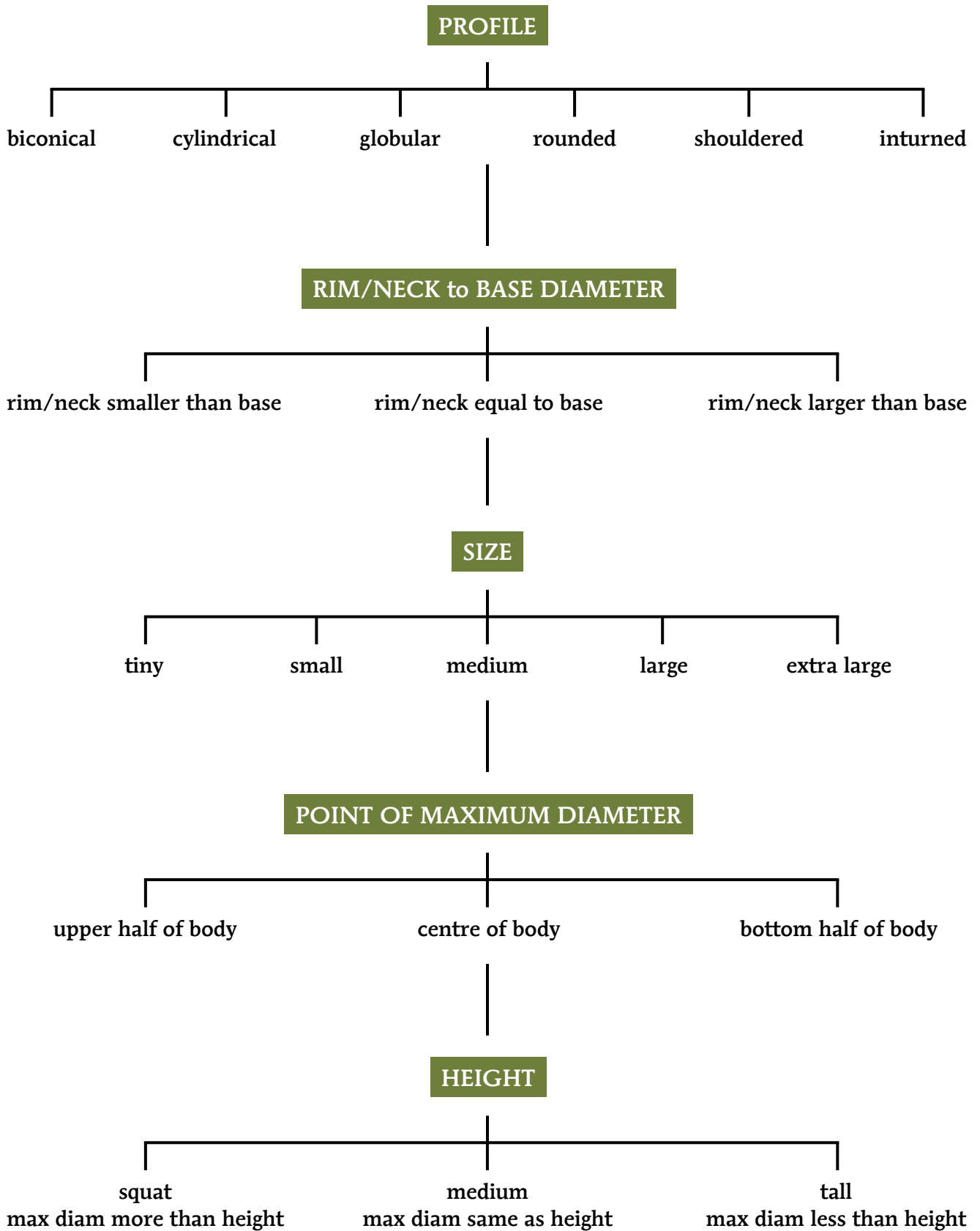



APPENDIX I

Classification of jar profiles

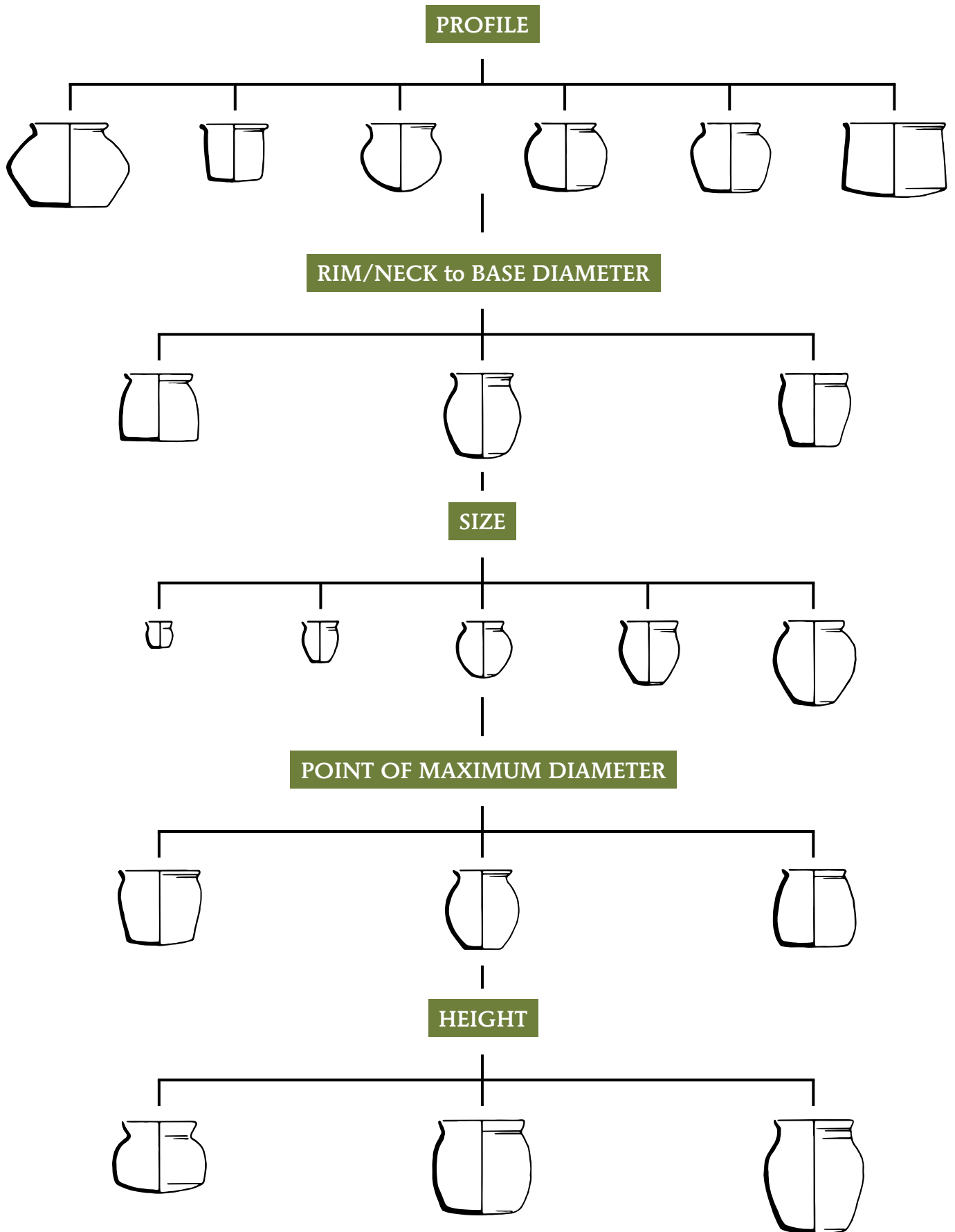

**APPENDIX I****Detailed classification of a single jar form**

The next two pages illustrate a method of further classification using only one profile shape of one vessel form, in this case a **ROUNDED JAR** form, and three characteristics – rim/neck to base diameter, point of maximum diameter, and height (squat, medium, tall). The characteristic ‘height’ is expressed as a ratio of the maximum horizontal dimension to the vertical dimension. In this example the ‘size’ characteristic is not used. By selecting drawings of complete vessels from across the country it was possible to find examples of all the subdivisions for this particular form, but this was by no means the case for all the jar profiles.

APPENDIX I

Detailed classification of a single jar form

Rim/neck to base diameter

rim/neck smaller than base

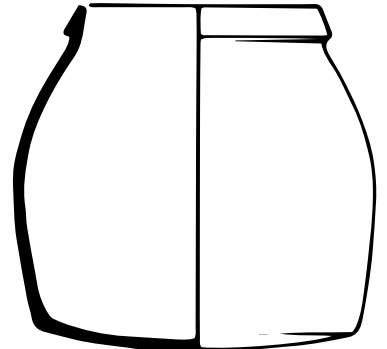
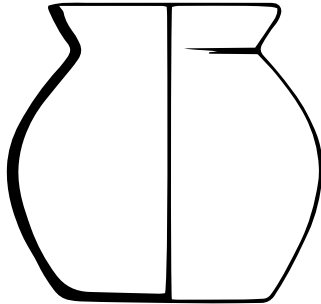
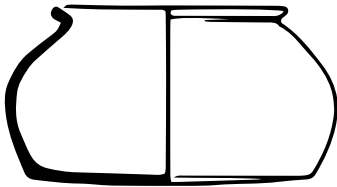

rim/neck equal to base

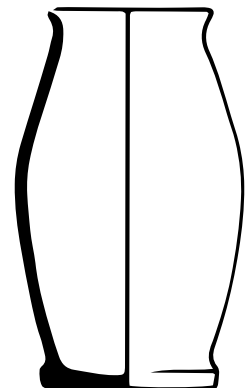
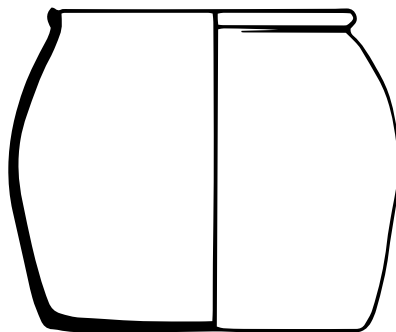
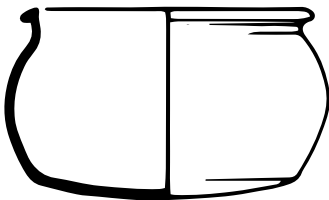

rim/neck larger than base

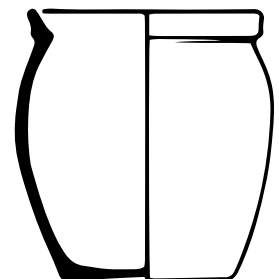
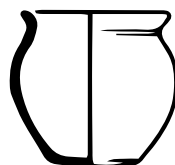
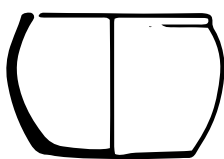

**APPENDIX I**

**Detailed classification of a single jar form**

**Point of maximum diameter**

**upper half of body**

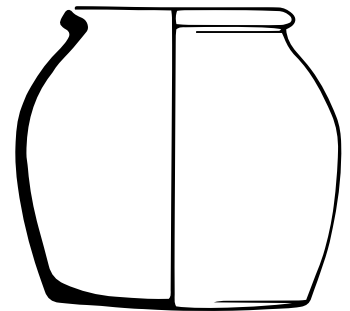
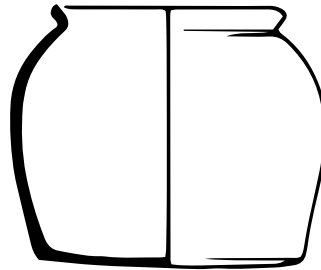
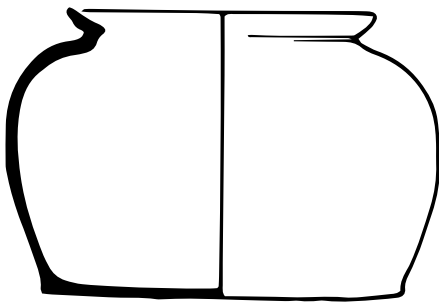

**centre of body**

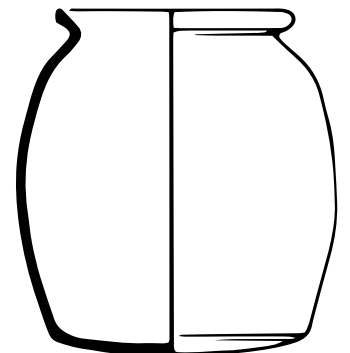
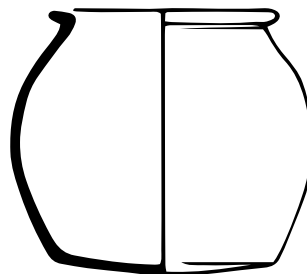

**bottom half of body**

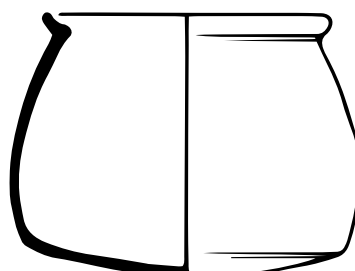
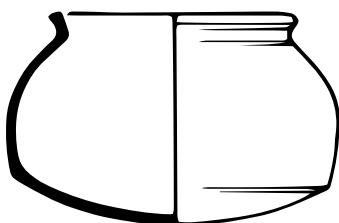

## INDICES

---

### Alphabetical Index

Acute-angled Base	11.1.2	Bird Pot	10.4
<i>Albarelo</i>	4.1.2	Biscuit firing	13.3
Alembic	9.1	<i>Bisque</i>	13.3
Alkaline Glaze	13.2	Blade trimming	13.2
Altar Vase	10.25	Bleeding Bowl	5.2
Aludel	9.2	Bloating	13.3
Amphora	10.1	Blow-out	13.3
Anthropomorphic Jug	3.1.11	Bonfire firing	13.3
Apple Roaster	8.10	Boss	12.3
Applied Decoration	12.1	<i>Botija</i>	10.23
Applied Feet	11.3.1	Bottle	3.2
Applied Lug	11.6.2	Bowl	5.1
Applied Spout	11.8.1	Bowl Curfew	8.5.1
Aquamanile	10.2	Box	9.9
Ash Glaze	13.2	Bridge spout	11.8.1
Attached spout	11.8.1	Brushing	13.2
Bacon Roaster	8.10	<i>Buckelurne</i>	4.1
Baking Tray	5.3.6	Bucket handle	11.4.1
Baluster Jug	3.1.1	Bucket-handled Jar	4.2.2
Bar Lip Jar	4.2.5	Bunghole Jar	4.5
Bar Lug Jar	4.2.4; 4.2.3	Bunghole Jug	3.1.17
Barrel Costrel	10.7.1	Bunghole Pitcher	3.1.17
Barrel-shaped Jug	3.1.2	Bungholes	11.2
Barrel-shaped Mug	6.3.1	Burnishing	13.2
<i>Bartmann</i>	3.1.8	Bushel Pan	4.2.1
Bases	11.1	Butter Pot	4.1
Basin	5.1	Candlemaker's Trough	9.9
Basket	5.2.3	Candlestick	8.1
Basket Handle	11.4.1	Carinated Bowl	5.1.2
Basket-handled Bowl	5.2.3	Carinated Cup	6.2.1
Basket-handled Jar	4.2.2	Carrot-shaped Olive Jar	10.23.1
Basket-handled Urinal	10.28.1	Cauldron	4.4
Beaker	6.1; 5.1.5	Chafing Dish	8.6
Bedpan	10.3	Chamber Candlestick	8.1.1
Beetle Trap	10.6	Chamber Pot	4.2.1
Bellarmino	3.1.8	Cheese Press	10.5
Bell-shaped Curfew	8.5.2	Chestnut Roaster	8.10
Bevelled Rim	11.7.3	Chicken Feeder	10.6
Beverage Warmer	8.9	Cistern	3.1.17; 4.5
Bib glaze	13.2	Clamp kiln	13.3
Biconical Bowl	5.1.1	Clay	13.1
Biconical Jar	4.1.1	Clay preparation	13.1
Biconical Jug	3.1.3	Clubbed rim	11.7.2
Bifid rim	11.7.2	Cockerel Bowl	5.2.4

Coil building	13.1	Distilling Base	9.4
Coiled Horn	10.16.3	Divided Bowl	5.1.11
Colander	5.1.13	Divided Dish	5.3.4
Collared Lid	7.1.1	Domed Lid	7.1.4
Collared rim	11.7.2	Domed Money Box	10.21.1
Collar Rim Cup	6.2.1	Double Dish	10.9
Combing	12.2; 13.2	Double-slipped sgraffito	12.6
Compartmented Lamp	8.2.1	Double-handled Bowl	5.2.4
Compartmented Tray	5.3.4	Double-handled Cup	6.2
Complex Lid	7.1.9	Double-handled Jar	4.2.3
Component parts	11	Double-shelled Lamp	8.2.2
Composite handle	11.4.1	Downdraught kiln	13.3
Concave base	11.1	Drawing	13.1
Concave-sided Bowl	5.1.3	Drinking Bowl	5.1
Concave-sided Jar	4.1.2	Drinking Jug	3.1
Condiment Bowl	5.1.11/12	Dripping Dish	5.3.6
Condiment Dish	5.3.4/5	Dripping Pan	5.3.6
Conical Jug	3.1.4	Dripping Tray	5.3.6
Conical Lid	7.1.2	Drip Tray	11.9.2
Conical Mug	6.3.2	Drop handle	11.4.1
Convex base	11.1.1	Drug Jar	4.1.3
Cooking Pot	4.1	Dunting	13.3
Core	13.1	Dutch Oven	8.10
Costrel	10.7	Earthenware	13.3
Cracking	13.1; 13.3	Encrustation	12.1; 13.2
Crawling	13.2	Engobe	13.2
Crazing	13.2	Everted rim	11.7.1
Cream Pan	5.1.4	Extended Horn	10.16.2
Crenellated rim	11.7.4	Fabric	13.1
Crenellation	11.9.1; 13.2	Face Jug	3.1.11
Cresset	8.2.6	Faceted base	11.1.3
Crucible	9.6; 8.2.3	Feeding Vessel	10.10
Cruet	10.8	Feet	11.3
Cucurbit	9.3	Fettling	13.2
Culinary Mould	5.3.4	Figure	12.1
Cup	6.2; 5.1; 5.2.1	Figurine Salt	10.11
Cupel	9.7	Fillet	13.1
Cup Salt	5.3.2	Finger/thumb impression	12.3
Curfew	8.5	Fingering	13.2
Curved Horn	10.16.1	Fire-bar	13.3
Cut-out	11.9.1; 13.2	Fire-box	13.3
Cut-out spout	11.8.1	Fire chamber	13.3
Cylindrical Costrel	10.7.2	Fire-clouding	13.3
Cylindrical Jar	4.1.3	Fire Cover	8.5
Cylindrical Jug	3.1.5	Fire Pot	8.7
Cylindrical Mug	6.3.3	Firing	13.3
Decoration	12	Fish Dish	5.3.6
Dish	5.3	Fish Smoker	10.12
Dish Crucible	9.6	Fish Trap	10.13
Dish Lid	7.1.3	Flanged Curfew	8.5.4

Flanged Lid	7.1.8	Hemispherical Bowl	5.1.5
Flanged rim	11.7.2	Hemispherical Curfew	8.5.2
Flared Bowl	5.1.4	Hemispherical Lamp	8.2.3
Flared Cup	6.2.2	Hollow Handle	11.4.1
Flared Curfew	8.5.1	Honey Pot	4.1
Flared Jar	4.1.4	Hooked handle	11.4.2
Flared Mug	6.3.4	Hooked rim	11.7.2
Flash-marks	13.3	Horn	10.16
Flask	3.3	Impressed decoration	12.3
Flattened Flask	3.3.1	Incised decoration	12.2
Flat base	11.1.1	Inclusion	13.1
Flat Lid	7.1.5	Incurved Dish	5.3.1
Flat rim	11.7.1	Industrial Base	9.4
Flat-topped Lid	7.1.6	Industrial Vessels	9
Flower Pot	10.14	Inkstand	10.17
Flower Vase	10.25	Inkwell	10.17
Flue	13.3	Integral lug	11.6.2
Flux	13.2	Inturned Dish	5.3.1
Foil	12.1	Inturned Jar	4.1.6
Footring	11.1.3	Inturned rim	11.7.1
Four-handled Bowl	5.2.5	Jars	4
Four-handled Jar	4.2.6	Jug	3.1
Fripped base	11.1.3	Kicked base	11.1.1
Frit	13.2	Kiln	13.3
Frying Pan	5.5; 5.2.1	Kiln furniture	13.3
Fuddling Cup	6.2.7	Knife-trimming	13.2
Fuming Pot	8.7	Knight Jug	3.1.12
Funerary Urn	4.1	Knobbed Money Box	10.21.3
Galena	13.2	Knobs	11.5
Galleried rim	11.7.2	Ladle	4.3
Ginger Jar	4.1.5	Lamp	8.2; 9.6
Glaze	13.2	Lantern	8.3
Globular Flask	3.3.2	Lathe-turning	13.2
Globular Jar	4.1.5	Lavabo	10.18
Globular Jug	3.1.6	Lead glaze	13.2
Globular Olive Jar	10.23.2	Leather-hard	13.1
Goblet	6.1	Legs	11.3.1
<i>Grape</i>	4.4	Levigation	13.1
Grenade	10.15	Lids	7
Grog	13.1	Lid knob	11.5.1
Gutter spout	11.8.1	Lid-seated rim	11.7.2
Half-round Curfew	8.5.3	Lighthouse Jug	3.1.4
Hammerhead rim	11.7.2	Lighting and Heating	8
Handforming	13.1	Limescale	13.4
Hand Lamp	8.1.1	Lip	11.8.2
Handled Bowl	5.2	Litharge	13.2
Handled Jar	4.2	Lobe	11.9.3
Handled Olive Jar	10.23.4	Lobed Bowl	5.1.10
Handles	11.4	Lobed Cup	6.2.6
Heating Stand	8.8	Lobed Dish	5.3.3

Locking Lid	7.1.8	Pedestal Cup	5.3.2; 6.2.5
Loop handle	11.4.1	Pedestal Dish	5.3.2
Lugs	11.6	Pedestal Goblet	6.1.1
Lustre	13.2	Pedestal Lamp	8.2.4
Luting	13.1	Pedestal Salt	5.3.2
Mammiform Costrel	10.7.3	<i>Pégau</i>	3.1.16; 3.1.8
Mammiform Money Box	10.21.2	Pellet	12.1
Mantle	9.5	Perforation	13.4
Manufacture	13	Pie-crust rim	11.7.4
Marbling	13.2	Piercing	13.2
Margin	13.1	Pinched spout	11.8.2
Measure	4.2.1	Pinching	12.3; 13.1
Meat Dish	5.3.6	Pipkin	4.3; 4.2.1
Mercury Jar	10.19; 4.1.7	Pirlie Pig	10.21
Milk Can	10.20	Pit kiln	13.3
Milk Churn	10.20; 4.2.2; 4.2.3	Pitcher	3.1
Miscellaneous Forms	10	Plain handle	11.4.2
Money Box	10.21	Plastic decoration	12.1
Mortar	10.22	Plate	5.4
Mortising	13.1	Pointed base	11.1.1
Mould	13.1	Porringer	5.2
Mould-stamping	12.3	Post-firing modification	13.4
Mug	6.3; 3.1	Pricket Lamp	8.2.6
Multi-handled Cup	6.2	Prop	13.3
Multi-handled Bowl	5.2.5	Pulled feet	11.3.2
Multi-handled Jar	4.2.6	Pulled spout	11.8.2
Multiple Bowl	5.1.12	Puzzle Cup	6.2.8
Multiple Dish	5.3.5	Puzzle Jug	3.1.13
Necked Cup	6.2.3	Recessed base	11.1.3
Obtuse-angled base	11.1.2	Rectangular lug	11.6.4
Ointment Jar	4.1.3	Reduction	13.3
Oil Jar	10.23	Repairs	13.4
Olive Jar	10.23	Residue	13.4
Open firing	13.3	Ribbed rim	11.7.4
Open spout	11.8.1	Right-angled base	11.1.2
Overfiring	13.3	Rims	11.7
Oxidisation	13.3	Rim support	11.5.1
Pad	12.1	Ring Flask	3.3.3
Painted decoration	12.4	Ring handle	11.4.1
Pan	5.1; 5.1.4	Ring Lamp	10.24
Pancheon	5.1; 5.1.3; 5.1.4	Ring Vase	10.24
Parrot beak spout	11.8.1	Ring-handled Vase	10.25
Parting Vessel	9.8	Riveting	13.1
Partition	11.9.4	Rod handle	11.4.1
Pear-shaped Jug	3.1.7	Rolled rim	11.7.2
Peat Pot	4.1.6; 5.3.1	Roller-stamping	12.3
Pedestal base	11.1.3	Rose-type Watering Pot	10.29.2
Pedestal Beaker	5.3.2; 6.1.1	Rouletting	12.3
Pedestal Bowl	5.1.9	Rounded base	11.1.1
		Rounded Beaker	6.1.2



Rounded Bowl	5.1.6	Spittoon	10.27
Rounded Cup	6.2.4	Splash glaze	13.2
Rounded Jar	4.1.7	Splayed base	11.1.3
Rounded Jug	3.1.8	Spouted Bowl	5.1.8
Rounded Mug	6.3.5	Spouted Pitcher	3.1.15
Rounded Olive Jar	10.23.3	Spouts	11.8
Rounded rim	11.7.3	Sprinkler Watering Pot	10.29.1
Rustication	13.2	Squared rim	11.7.2
Saggar	13.3	Stabbing	12.2
Sagging base	11.1.1	Stacking Alembic	9.1
Salt glaze	13.2	Stacking rings	13.3
Salt Kiln, Kit	10.26	Stacking scars	13.3
Saucepan	5.5.1	Stamped decoration	12.3
Saucer	5.3; 11.9.2	Stamping	12.3
Saucer Candlestick	8.1.1	<i>Standfussschale</i>	5.1.9
Saucer Lamp	8.2.5	Standing Costrel	10.7.4
Saucer-shaped Lid	7.1.7	Stemmed Beaker	6.1.1
Scale	12.1	Stemmed Goblet	6.1.1
<i>Schalenurne</i>	5.1.1	Stoneware	13.3
<i>Schnelle</i>	6.3.2	Stool Pan	5.1.4; 5.2.1
Scoring	13.2	Storage Jar	4.1
Scratch-marking	12.2; 13.2	Straight-edged rim	11.7.3
Second	13.3	Straight handle	11.4.2
Self-slip	13.2	Straight-sided Bowl	5.1.7
Settling Pan	5.1.4	Strainer	5.1.13
Sgraffito decoration	12.6	Strap handle	11.4.1
Shelled Lamp	8.2.5	String marks	13.1
Shouldered Jar	4.1.8	Strip	12.1
Shouldered Jug	3.1.9	Struts	11.9.6
Side handle	11.4.1	Sugar Cone Mould	9.10
Side-handled Urinal	10.28.2	Supports	11.5
Simple rim	11.7.2	Surface	13.1
Single-handled Bowl	5.2.1	Surface modification	13.2
Single-handled Jar	4.2.1	Surface treatment	13.2
Skillet	5.5.1	Suspension glaze	13.2
Slab-building	13.1	Sweetmeat Dish	5.3.2
Slashing	12.2	Syrup-collecting Jar	9.11
Slip	12.5; 13.2	Tankard	6.3; 6.3.2
Slip-casting	13.1	<i>Tazza</i>	5.1.9; 5.3.2
Slipped decoration	12.5	Temper	13.1
Slurry	13.2	Template	13.1
Smoothing	13.2	Texturing	13.2
Socketed Bowl	5.2.2; 5.2.1	Thickened rim	11.7.2
Socketed handle	11.4.2	Thistle Tyg	6.2.3
Sockets	11.9.5	Three-handled Bowl	5.2.5
Sooting	13.4	Three-handled Cup	6.2
Spacer	13.3	Three-handled Jar	4.2.6
Spalling	13.3	Three-handled Jug	3.1
Spike Lamp	8.2.6	Throwing	13.1
Spit-out	13.3	Throwing rings	13.1

Thumb Crucible	9.6	Updraught kiln	13.3
Thumbed base	11.1.3	Upright Candlestick	8.1.2
Thumbed feet	11.3.2	Upright rim	11.7.1
Thumbed rim	11.7.4	Upstanding handle	11.4.1
Thumbing	12.3; 13.2	Urinal	10.28; 4.2.1
Tin glaze	13.2	Urn	4.1
Tray	5.3	User's Guide	2
Trefoil spout	11.8.2	Vase	4.1.8
Triangular Crucible	9.6	Vent	11.9.1, 13.2
<i>Trichterhalskrug</i>	6.3.5	Waisted Beaker	6.1.3
Trimming	13.2	Waisted Jug	3.1.10
Tripod Jug	3.1.14	Warbler	10.30
Tripod Pipkin	4.3.1	Warming Pan	8.4
Tripod Pitcher	3.1.14	Warping	13.3
Trivet	13.3	Wash	13.2
Tubular handle	11.4.2	Waster	13.3
Tubular spout	11.8.1	Watering Pot	10.29
Turning	13.2	Wear marks	13.4
Turntable	13.1	Wedging	13.1
Twisted handle	11.4.1	'West Country' Dish	4.1.6; 5.3.1
Two-handled Bowl	5.2.4	Wet sgraffito	12.6
Two-handled Cup	6.2	Wheel	13.1
Two-handled Jar	4.2.3	Whistle	10.30
Two-handled Jug	3.1	Wire marks	13.1
Tyg	6.3.4	Zoomorphic Jug	3.1.11
Underfiring	13.3	Zoomorphic Money Box	10.21.4

## Alternative Form Names

Alternative Name	See Under	
<i>Albarello</i>	CONCAVE-SIDED JAR	4.1.2
Altar Vase	RING-HANDLED VASE	10.25
Anthropomorphic Jug	FACE JUG	3.1.11
Apple Roaster	DUTCH OVEN	8.10
Bacon Roaster	DUTCH OVEN	8.10
Baking Tray	DRIPPING DISH	5.3.6
<i>Bartmann</i>	ROUNDED JUG	3.1.8
Basin	BOWL	5.1
Basket	BASKET-HANDLED BOWL	5.2.3
Beetle Trap	CHICKEN FEEDER	10.6
Bellarmino	ROUNDED JUG	3.1.8
Bell-shaped Curfew	HEMISPHERICAL CURFEW	8.5.2
Bleeding Bowl	HANDLED BOWL	5.2
<i>Botija</i>	OLIVE JAR	10.23
Bowl Curfew	FLANGED CURFEW	8.5.4
Box	CANDLEMAKER'S TROUGH	9.9
<i>Buckelurne</i>	JAR	4.1
Bucket-handled Jar	BASKET-HANDLED JAR	4.2.2
Bunghole Pitcher	BUNGHOLE JUG	3.1.17
Bushel Pan	SINGLE-HANDLED JAR	4.2.1
Butter Pot	JAR	4.1
Chamber Candlestick	SAUCER CANDLESTICK	8.1.1
Chamber Pot	SINGLE-HANDLED JAR	4.2
Chestnut Roaster	DUTCH OVEN	8.10
Cistern	BUNGHOLE JAR; BUNGHOLE JUG	4.5 3.1.17
Cockerel Bowl	DOUBLE-HANDLED BOWL	5.2.4
Collar Rim Cup	CARINATED CUP	6.2.1
Compartmented Tray	DIVIDED DISH	5.3.4
Condiment Bowl	DIVIDED BOWL; MULTIPLE BOWL;	5.1.11 5.1.12
Condiment Dish	DIVIDED DISH; MULTIPLE DISH	5.3.4 5.3.5
Cooking Pot	JAR	4.1
Cream Pan	FLARED BOWL	5.1.4
Cresset	SPIKE LAMP	8.2.6
Cup Salt	PEDESTAL DISH	5.3.2
Dish Crucible	CRUCIBLE	9.6
Distilling Base	INDUSTRIAL BASE	9.4
Double-handled Cup	CUP	6.2
Drinking Bowl	CUP BOWL	6.2 5.1
Drinking Jug	JUG	3.1
Dripping Pan	DRIPPING DISH	5.3.6
Dripping Tray	DRIPPING DISH	5.3.6
Drug Jar	CYLINDRICAL JAR	4.1.3

Fire Cover	CURFEW	8.5
Fire Pot	FUMING POT	8.7
Fish Dish	DRIPPING DISH	5.3.6
Flower Vase	RING-HANDLED VASE	10.25
Four-handled Bowl	MULTI-HANDLED BOWL	5.2.5
Four-handled Jar	MULTI-HANDLED JAR	4.2.6
Funerary Urn	JAR	4.1
Ginger Jar	GLOBULAR JAR	4.1.5
Goblet	BEAKER	6.1
<i>Grape</i>	CAULDRON	4.4
Hand Lamp	SAUCER CANDLESTICK	8.1.1
Honey Jar	JAR	4.1
Incurved Dish	INTURNED DISH	5.3.1
Inkstand	INK WELL	10.17
Ladle	PIPKIN	4.3
Lighthouse Jug	CONICAL JUG	3.1.4
Locking Lid	FLANGED LID	7.1.8
Measure	SINGLE-HANDLED JAR	4.2.1
Meat Dish	DRIPPING DISH	5.3.6
Milk Can	MILK CHURN	10.20
Multi-handled Cup	CUP	6.2
Ointment Jar	CYLINDRICAL JAR	4.1.3
Oil Jar	JAR;	4.1;
	OLIVE JAR	10.23
Pan	CONCAVE-SIDED BOWL;	5.1.3;
	FLARED BOWL	5.1.4
Pancheon	CONCAVE-SIDED BOWL;	5.1.3;
	FLARED BOWL	5.1.4
Peat Pot	INTURNED JAR	4.1.6
Pedestal Salt	PEDESTAL DISH	5.3.2
Pirlie Pig	MONEY BOX	10.21
Pitcher	JUG	3.1
Porringer	HANDLED BOWL	5.2
Pricket Lamp	SPIKE LAMP	8.2.6
Ring Lamp	RING VASE	10.24
Salt Kiln	SALT KIT	10.26
Saucepan	SKILLET	5.5.1
Saucer	DISH	5.3
<i>Schalenuerne</i>	BICONICAL BOWL	5.1.1
<i>Schnelle</i>	CONICAL MUG	6.3.2
Settling Pan	FLARED BOWL	5.1.4
Shelled Lamp	SAUCER LAMP	8.2.5
Stacking Alembic	ALEMBIC	9.1
<i>Standfusschale</i>	PEDESTAL BOWL	5.1.9
Stemmed Beaker	PEDESTAL BEAKER	6.1.1
Stemmed Goblet	PEDESTAL BEAKER	6.1.1
Stool Pan	FLARED BOWL	5.1.4
	SINGLE-HANDLED BOWL	5.2.1
Storage Jar	JAR	4.1

Strainer	COLANDER	5.1.13
Sweetmeat Dish	PEDESTAL DISH	5.3.2
Tankard	MUG	6.3
	CONICAL MUG	6.3.2
<i>Tazza</i>	PEDESTAL BOWL;	5.1.9;
	PEDESTAL DISH	5.3.2
Thistle Tyg	NECKED CUP	6.2.3
Three-handled Bowl	MULTI-HANDLED BOWL	5.2.5
Three-handled Cup	CUP	6.2
Three-handled Jar	MULTI-HANDLED JAR	4.2.6
Thumb Crucible	CRUCIBLE	9.6
Tray	DISH	5.3
<i>Trichterhalskrug</i>	ROUNDED MUG	6.3.5
Tripod Jug	TRIPOD PITCHER	3.1.14
Two-handled Bowl	DOUBLE-HANDLED BOWL	5.2.4
Two-handled Cup	CUP	6.2
Two-handled Jar	DOUBLE-HANDLED JAR	4.2.3
Two-handled Jug	JUG	3.1
Tyg	FLARED MUG	6.3.4
Urn	JAR	4.1
Vase	SHOULDERED JAR	4.1.8
Warbler	WHISTLE	10.30
West Country Dish	INTURNED DISH	5.3.1
Zoomorphic Jug	FACE JUG	3.1.11

## MEDIEVAL CERAMIC FORMS: proposal for a new entry

---

To offer a ceramic form for inclusion in a supplement to this Guide, please complete a copy of the proforma overleaf. Use the back of your copy if you need more room. Send it to

### **MPRG (MCF)**

**secretary@medievalpottery.org.uk**

Please provide **evidence** for any name proposed for the vessel. Is it for example from documentary or pictorial evidence, local dialect or otherwise supported. If it is already published, give the full bibliographical reference. If it is not yet published, give Site, County, NGR, brief context description, context, date etc., brief information about associated material, ceramic and other, and the name of the organisation holding the vessel.

If possible, please send a photograph as well as conventional drawings in elevation and section with details of decoration, handles, etc., and views as necessary. Show the extent of survival by indicating any additions or reconstruction. If you can, give consent for any drawing supplied to be the basis for a drawing in a published supplement, by signing the form at the bottom.

Please give your name, address, telephone number and the date.

## MEDIEVAL CERAMIC FORMS: proposal for Section .....

**Form Category** (e.g. Jug/Bowl/Cup/Misc.) .....

**Suggested Name** .....

**Defining characteristics:** .....

.....

.....

.....

.....

.....

**Variations:** .....

**Bibliography:** .....

**Present location of vessel:** .....

**Illustrations:** (state scale)