

shades of different sizes, glass tiles, about 100 tons of best pot clay, 50 bags of nails, shovels, ladles, iron bowls, five tons of salt cake, ground lime, cement clay, arsenic & c.

The PLANT, FIXTURES and UTENSILS comprise two bogies [*sic*] carts, 200 large drassers [*sic*], two stoves and pipes, three flattening stone carriages, four good flattening stones, two large plate and plain glass roll tables, 43 iron moulding blocks, weighing machine (by Bartlett), two pairs of patent forge bellows, two vices and tools, rasps, files, shears, one large pot setting machine, one pair of pot setting wheels, wheel barrows, office furniture, iron safe. Also rick of new-made hay, three horses, three carts, three sets cart harness, one trolley, & c.”⁴²

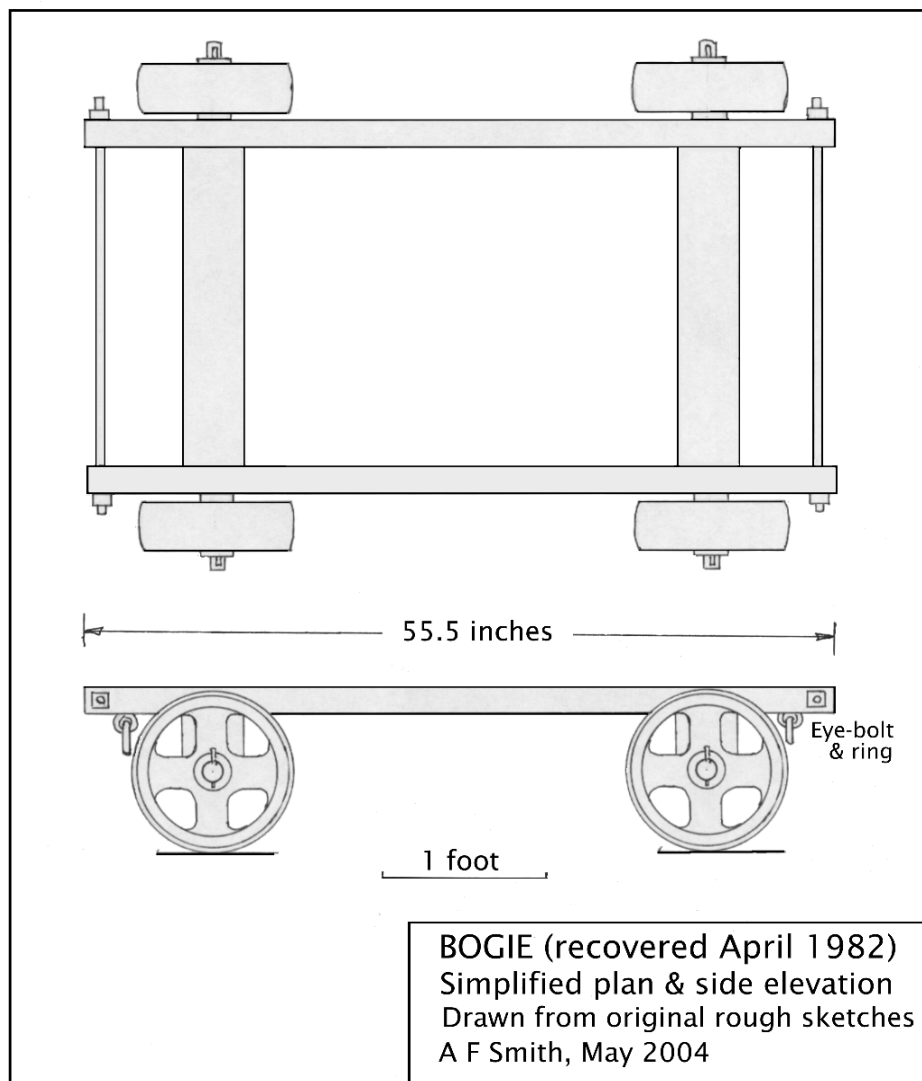

Figure 3.14: Glassworks bogie , possibly from annealing kiln, Nailsea

⁴² Bristol Times and Mirror, 7th August 1869, p.1, col.7. From transcript in SMR 2397, Folder E

Reference to the bogie may be found in Part 2, 1982. The original sketches are difficult to interpret, so only a simple outline has been attempted in Figure 3.14. [There also appears to be iron braces to the axles and a shaped iron plate fixed to a transverse bar, of unknown purpose. The original bogie is in store at the North Somerset Museum at Weston-super-Mare, but has not been seen.]



Figure 3.15: Pot changing forks (Red House Cone)



Figure 3.16: Glass blowers' chairs (Red House Cone)

The above pictures, Figures 3.15 and 3.16, speak for themselves.

The following picture, Figure 3.17, below, is of a selection of tools from the Red House Cone,