



Chenies Manor, Chenies, Buckinghamshire

An Archaeological Evaluation of a Tudor Manor
House and an Assessment of the Results



Ref: 55751
January 2005

CHENIES MANOR, CHENIES, BUCKINGHAMSHIRE.

**AN ARCHAEOLOGICAL EVALUATION OF A TUDOR MANOR
HOUSE AND
AN ASSESSMENT OF THE RESULTS**

**Document Ref. 55751
January 2005**

Prepared for:

**Videotext Communications Ltd
49 Goldhawk Road
LONDON
SW1 8QP**

By:

**Wessex Archaeology
Portway House
Old Sarum Park
SALISBURY
Wiltshire
SP4 6EB**

© Copyright The Trust for Wessex Archaeology Limited 2005, all rights reserved

The Trust for Wessex Archaeology Limited, Registered Charity No. 287786

CHENIES MANOR, CHENIES, BUCKINGHAMSHIRE.

AN ARCHAEOLOGICAL EVALUATION OF A TUDOR MANOR HOUSE AND AN ASSESSMENT OF THE RESULTS

CONTENTS

SUMMARY	IV
ACKNOWLEDGEMENTS	VII
1 INTRODUCTION.....	1
1.1 PROJECT BACKGROUND	1
1.2 GEOLOGY AND TOPOGRAPHY	2
1.3 ARCHAEOLOGICAL AND HISTORICAL BACKGROUND	2
1.4 PREVIOUS ARCHAEOLOGICAL INVESTIGATIONS.....	9
2 METHODS	11
2.1 INTRODUCTION	11
2.2 AIMS AND OBJECTIVES	11
<i>Trial Trenching</i>	11
<i>Geophysics Survey (by GSB Prospection Limited)</i>	12
<i>Dendrochronology (by Michael Worthington and Daniel Miles)</i>	13
2.3 FIELDWORK METHODS	14
3 RESULTS	15
3.1 INTRODUCTION	15
3.2 GEOPHYSICAL SURVEY (BY GSB PROSPECTION LIMITED).....	15
<i>Ground penetrating radar survey (Figure 3)</i>	15
<i>Resistivity survey (Figure 4)</i>	17
3.3 DENDROCHRONOLOGY (BY MICHAEL WORTHINGTON AND DANIEL MILES).....	18
<i>The West Range</i>	18
<i>The South Range</i>	18
<i>The Linking Block</i>	19
3.4 ARCHAEOLOGICAL EVALUATION	19
<i>Trench 1 (Figure 6)</i>	19
<i>Trench 2 (Figure 7)</i>	20
<i>Trench 3 (Figure 8)</i>	22
<i>Trench 4</i>	22
<i>Trench 5</i>	23
<i>Trench 6 (Figure 9)</i>	23
<i>Trench 7 (Figure 10)</i>	23
<i>Trench 8 (Figure 10)</i>	24
<i>Trench 9</i>	24
<i>Trench 10</i>	24
<i>Trench 11 (Figure 9)</i>	25
<i>Trench 12 (Figure 11)</i>	25
<i>Trench 13 (Figure 10)</i>	30
<i>Trench 14 (Figure 12)</i>	30
<i>Trench 15</i>	30
<i>Trench 16</i>	31
<i>Trench 17 (Figure 12)</i>	31
<i>Trench 18 (Figure 11)</i>	31

4	FINDS	31
4.1	INTRODUCTION.....	31
4.2	POTTERY.....	32
4.3	CERAMIC BUILDING MATERIAL.....	33
4.4	CLAY PIPE.....	34
4.5	GLASS.....	34
4.6	STONE.....	34
4.7	WORKED FLINT.....	34
4.8	METALWORK.....	34
	<i>Copper Alloy</i>	34
	<i>Iron</i>	35
	<i>Lead</i>	35
4.9	ANIMAL BONE.....	35
4.10	MARINE SHELL.....	36
5	ENVIRONMENTAL SAMPLES	38
6	DISCUSSION	38
7	RECOMMENDATIONS FOR FURTHER WORK.....	42
8	THE ARCHIVE	42
9	BIBLIOGRAPHY	43
	APPENDIX 1. TRENCH DESCRIPTIONS.....	45
	APPENDIX 2. SUMMARY OF TREE-RING DATING FOR CHENIES MANOR.....	54
	Table 1: Animal bone Species list and percentages (NISP).....	38
	Table 2: All finds by Trench (number / weight in grammes).....	40
Figure 1:	Site location plan.	
Figure 2:	Plan of the standing buildings of Chenies Manor mentioned in the text.	
Figure 3:	Results of the Ground Penetrating Radar Survey.	
Figure 4:	Results of the Resistivity Survey.	
Figure 5:	Trench layout.	
Figure 6:	Trench 1.	
Figure 7:	Trench 2.	
Figure 8:	Trench 3.	
Figure 9:	Trenches 6 and 11.	
Figure 10:	Trenches 7, 8, and 13.	
Figure 11:	Trenches 12 and 18	
Figure 12:	Trenches 14 and 17	
Figure 13	–Not yet prepared. Includes 1839 Tithe Map and interpretation thereof	
Figure 14	Summary of the results. Needs completing. Awaiting comments.	
Plate 1:	Trench 12 under excavation from south west	
Plate 2:	Trench 12 under excavation from north east	
Plate 3:	Recording Trench 12	
Plate 4:	Bay window 1217	
Plate 5:	Bay window 1207.	
Plate 6:	Trench 12 from South.	

CHENIES MANOR, CHENIES, BUCKINGHAMSHIRE.

AN ARCHAEOLOGICAL EVALUATION OF A TUDOR MANOR HOUSE AND AN ASSESSMENT OF THE RESULTS

Summary

Wessex Archaeology was commissioned by Videotext Communications Ltd to undertake a programme of archaeological recording and post-excavation work on an archaeological evaluation undertaken by Channel 4's 'Time Team' at Chenies Manor, Chenies, Buckinghamshire, centred on NGR 501500 198350 (Figure 1).

Chenies Manor is located approximately 5km east of Amersham and around 1.5km to the north west of Little Chalfont, close to the county boundary between Hertfordshire and Buckinghamshire. The Manor lies just on the western edge of the village, adjacent to St. Michael's church. The present manor house lies on the site of the Medieval manor house, the undercroft of which is incorporated within the present house, and is a Scheduled Monument (SM No 27145). The surviving remains of the manor house predominantly date to the Tudor or Post-medieval period, and are a Grade I Listed Building.

The stated aim of the project was to ascertain the character, extent and degree of preservation of the archaeological remains at Chenies Manor. Documents relating to the visits to Chenies by both Henry VIII and Elizabeth I, as well as the description of the manor in the Itinerary of John Leland, indicate that the site saw much construction during the Tudor period (initially instigated by John Russell). Later documents refer to the demolition and abandonment of some of the wings of the manor, and it is clear that there is a complex history of construction, modification, abandonment and demolition of different elements of the manor throughout the Tudor and Post-medieval periods.

The archaeological work at Chenies was predominantly intended to examine the evidence for the Tudor history of the site, and in particular the transformation and remodelling of the inherited Medieval manor by John Russell, into a house fit for the visits of King Henry VIII. The house as it stands today is clearly not large enough to have housed the King and his vast retinue, and the documentary sources mention additional ranges of buildings to those which survive. The location of these Tudor remains and structures is unclear, and the project sought to shed further light on the extent and nature of the Tudor manor in its heyday.

Geophysical survey was undertaken by GSB Prospection Ltd to establish the likely location of buried walls and features relating to the complex. A total of six areas were surveyed using ground penetrating radar (GPR) and/or resistance, according to the ground conditions. A large number of anomalies were identified, many of which may

represent the remains of demolished structures. Investigation of a number of these confirmed the interpretation of these anomalies as archaeological.

Dendrochronology work on the site was undertaken by Michael Worthington and Daniel Miles of the Oxford Dendrochronology Laboratory. Samples taken from structural timbers within the surviving west range precise felling dates ranging from spring 1537 to summer 1538. Samples taken from the South range suggest that this was constructed at a later date, with seven precise dates from the Long Gallery roof suggesting that the south range was constructed during 1552 or very shortly afterwards. Three samples from the linking block between the south range to the staircase tower in the west range suggest that it is probably contemporary with, or saw major reconstruction during the construction of the south range.

Eighteen trenches were excavated during the course of the evaluation. These were targeted either on areas identified in the project design, or on areas identified by the geophysical survey. They were excavated to the east, north and west of the current house.

The evaluation revealed evidence for a phase of 12th and 13th century occupation on the Site, in the form of a number of features cut in to the natural drift geology of the site. Two parallel ditches were excavated in Trench 2, whilst removal of areas of the Tudor and Post-medieval garden soil in Trench 12 revealed two substantial features that may represent either pits or ditch termini. Additional Medieval material was recovered from both later and unstratified deposits in Trenches 4, 7, 8 and 12, further indicating the presence of Medieval activity on the Site during the 12th and 13th centuries. This material, and the favourable location of the site on a slight rise to the west of the parish church suggest that this was the location of Isenhampstead Manor.

Structural remains relating to the Tudor manorial complex were identified in a number of different trenches. These represent the remains of the north range, recorded as ruinous in the 18th century, the eastern wall of the courtyard and a substantial range to the north west of the current manor house. This latter (in Trench 12) showed evidence for a complex structural history, one of the last phases of which was the addition of two bay windows to the north front of the complex. This probably represents an upgrading of these rooms, possibly in advance of one of the Royal visits. This range may have formed the main accommodation block, with large windows overlooking the gardens to the north. A walkover survey of the site suggests that the complex was originally approached from the west, and had extensive formal gardens to the north of the manor and a Privy garden to the south. The manor probably also had two hunting parks located to the west and south west of the complex.

Unfortunately, the expense of maintaining so large a complex proved too great for the Russell family, especially after their decision to use Woburn as their main family home. Chenies was subsequently managed by a steward, and some of the buildings used as part of Manor Farm. The north wing and the range to the north west were either dismantled or allowed to fall into ruin. Some later features were identified, including Post-medieval or Victorian wall footings and features.

In view of the significance of the results of this work, it is recommended that a programme of further analysis be undertaken with a view to the publication of a short article outlining the results of this investigation in an appropriate journal. This should provide the background to the project, a summary of the main findings, and a concluding discussion. Plans, sections and photographs may be used to provide illustrative accompaniment to the text as appropriate. The site data contained within this assessment should be used to form the basis of the structural report.

CHENIES MANOR, CHENIES, BUCKINGHAMSHIRE.

AN ARCHAEOLOGICAL EVALUATION OF A TUDOR MANOR HOUSE AND AN ASSESSMENT OF THE RESULTS

Acknowledgements

This programme of post-excavation and assessment work was commissioned and funded by Videotext Communications. Wessex Archaeology would like to thank the staff at Videotext, and in particular Zarina Dick and Melinda Smith (Executive Producers), Nick Gillam-Smith (Assistant Producer) and Kate Edwards (Researcher) for their considerable help during the recording and post-excavation work.

The extensive collaboration and enthusiastic support during the project by Elizabeth McCleod Matthews, the current owner of Chenies Manor, is especially acknowledged.

The evaluation strategy was developed by Professor Mick Aston (Bristol University), and all fieldwork undertaken by Time Team's retained excavators with help from members of Archaeological Solutions Ltd (Mark Gibson, Jon Grant, Steve Turner, and Louise Wood). The on-site recording was undertaken and co-ordinated by Nicholas Cooke, assisted by Steve Thompson, both of Wessex Archaeology. The finds were processed on-site by Steve Thompson.

The geophysical survey was conducted by John Gater, Chris Gaffney and Jimmy Adcock from GSB Prospection Limited. The field survey was undertaken by Dr Henry Chapman, University of Hull.

Wessex Archaeology co-ordinated the post excavation programme. This report was compiled by Nicholas Cooke. Specialist work and reporting was undertaken by Lorraine Mepham and Steve Thompson (finds), Dr Stephanie Knight (animal bone), Mick Worthington and Daniel Miles (Dendrochronology) and J Anderson and E Wood (Geophysics). The illustrations were prepared by Kitty Brandon. The project was managed on behalf of Wessex Archaeology by Nicholas Cooke.

The progress of the work in the field also benefited from advice and discussion with various specialists, including Dr Jonathan Foyle (Buildings Historian), Mick Worthington (Dendrochronologist), Debbie Ford (Tudor and Post-medieval finds), Robert Demaus (Thermal imaging) and John Guy (Historian). Nicholas Cooke would particularly like to acknowledge the advice and assistance given to him by Dr Jonathan Foyle in interpreting the remains of the Tudor buildings.

CHENIES MANOR, CHENIES, BUCKINGHAMSHIRE.

AN ARCHAEOLOGICAL EVALUATION OF A TUDOR MANOR HOUSE AND AN ASSESSMENT OF THE RESULTS

1 INTRODUCTION

1.1 Project Background

- 1.1.1 Wessex Archaeology was commissioned by Videotext Communications Ltd to undertake a programme of archaeological recording and post-excavation work on an archaeological evaluation undertaken by Channel 4's 'Time Team' at Chenies Manor, Chenies, Buckinghamshire, centred on NGR 501500 198350 (Figure 1).
- 1.1.2 Chenies Manor is located approximately 5km east of Amersham and around 1.5km to the north west of Little Chalfont, close to the county boundary between Hertfordshire and Buckinghamshire. The Manor lies just on the western edge of the village, adjacent to St. Michael's church. The present manor house lies on the site of the Medieval manor house, the undercroft of which is incorporated within the existing house, and is a Scheduled Monument (SM No 27145). The surviving remains of the manor house predominantly date to the Tudor or Post-medieval period, and are designated a Grade I Listed Building.
- 1.1.3 Chenies Manor was visited by both Henry VIII, who stayed there on two occasions - in 1534 and 1540 – and Elizabeth I, who stayed there in 1570. It is clear from inventories and descriptions of the house at the time that it was considerably larger than the two wings that form the present manor house.
- 1.1.4 The main surviving Tudor elements of the complex comprise the south and west ranges, joined by a small linking block (Figure 2) These form two sides of a courtyard, now largely grassed, the northern and eastern boundaries of which are currently formed by brick walls. To the west of this complex are the largely rebuilt remains of a building now known as the Old Nursery and the Pump House. The Late Medieval undercroft lies to the north of the West range, and is accessed from a modern structure. To the west and north west of the house are a number of modern barns and sheds, along with substantial areas of hardstanding. Formal walled gardens lie to the north of the courtyard and to the south and south west of the south range. Other traces of earlier structures and boundaries include a Tudor style fireplace now built into the western wall of the churchyard, and a terrace edge and boundary wall to the north of the manor complex.

- 1.1.5 This report documents the results of archaeological survey and evaluation undertaken by Time Team, and presents an assessment of the results of these works, along with recommendations for further analysis and dissemination.

1.2 Geology and Topography

1.2.1 The Site lies on a relatively flat hilltop, at a height of some 122m aOD (above Ordnance Datum). It is located some 400m to the south of the course of the River Chess, which forms the boundary between Hertfordshire and Buckinghamshire. The Site is bounded to the east by the village of Chenies, to the north and south by fields and farmland, and to the west by Greathouse Farm.

1.2.2 The local soils of the area belong to the Coombe 1 and Marlow Associations. These comprise chalky and clayey river terrace and plateau drift soils (Soil Survey of England and Wales, 1993). The drift geology in the vicinity of the site comprises pebbly clay with sand overlying soft white chalk with flints (British Geological Survey, 1990; England and Wales sheet 255; 150; 1:50,000).

1.3 Archaeological and historical background

1.3.1 Chenies Manor lies amidst a complex archaeological landscape. The Site's broader environs have been occupied since the Palaeolithic period (*c.* 500,000 BC) and used variously for settlement and agriculture.

1.3.2 There is very little evidence for occupation or other activity in the prehistoric period within the immediate or local vicinity of the site. A single Acheulian handaxe represents the only Palaeolithic artefact recorded in the area. The exact location of this findspot is not recorded, other than the fact that it came from Chenies Parish (NMR 395245). Small quantities of Mesolithic worked flint have also been found in the area, but there is no good evidence for Neolithic, Bronze Age or Iron Age activity in the vicinity of the Site.

1.3.3 A number of sites and findspots of Roman material have been recorded in the local area, including several villas. One villa was built at Chenies itself, to the north east of the church. This was constructed during the last quarter of the 1st century AD, and grew in size during the 2nd and 3rd centuries with the addition of further rooms and a new bathhouse, reaching its peak during the fourth century. The presence of late Roman mosaics highlight its sophistication at this time.

1.3.4 A number of smaller sites are also known from the region, whilst findspots of Roman pottery, building material and coins are common. A Roman coin hoard was found to the south of the villa at Chenies, whilst Roman tile fragments have been found at Flaunden Bottom to the north of the Site.

- 1.3.5 There is little evidence for Early Saxon settlement in the area - the few known sites appear concentrated on the line of the Icknield Way (HAT, 2000, 5). The Late Saxon settlement at Chenies was known as *Isenhamstede*, a name which may relate to its position on the river. The name probably derives from the 'hamstead' on the River 'Isen' – presumably the Saxon name for the Chess (Ekwall, 1960, 100). The Domesday Book does not mention the settlement at Isenhamstead itself, which probably lay within the manor at Chesham. The Domesday Book entry for Chesham indicates that at the time of the Domesday Survey, it was held by Alsi:

“Alsi holds 4 hides in Chesham from the King. Land for 9 ploughs; in lordship 1½ hides; 2 ploughs there. 10 villagers with 5 smallholders have 7 ploughs. 6 slaves, meadow for 2 ploughs; woodland, 800 pigs; 1 mill. The value is and was £4; before 1066, 100s. Queen Edith held this manor; she gave it to Alsi after King William’s arrival”

- 1.3.6 Alsi appears to have been a lady in waiting to Queen Edith, and had probably been granted the manor as a wedding present. The fact that the grant was allowed to stand is itself interesting, especially as it appears to have been made after the Conquest. Isenhamstead is first mentioned in 1165, in connection with one 'Alexander of Isenhamstead', who held the manor for a knight's fee. The name of Chenies was probably first applied to the manor during the 13th or early 14th century to distinguish it from the nearby Isenhamstead Latimer.

- 1.3.7 The church at Chenies, dedicated to St Michael, stands to the east of Chenies Manor. It is first mentioned in 1232, although elements of the current building date to the 12th century. The church saw much rebuilding, both in the Medieval and Victorian periods. A Medieval watermill, first documented in the 12th century, lay to the west north west of the current manor house on the River Chess (NMR 1028879). The first of the Chenyes to own the manor was Alexander Cheyne. Upon his death, the manor passed to his son John (later Sir John).

- 1.3.8 In 1285, with the death of Sir John Cheyne, who was Sheriff of Buckinghamshire and Bedfordshire in 1278, the manor was taken over by Edward I in lieu of a debt, and he spent time hunting here. At the time he also held a nearby manor of King's Langley, and Chenies became a 'Chamber manor' - a personal rather than an official possession. The manor was valued at £11 4s 3d at the time, and John's widow Joan was allowed to draw a pension from the manor. (VCH, 1923, 200)

- 1.3.9 Some documents survive referring to Edward's ownership of the manor. The first of these is an order issued to the sheriffs of London to convey two tuns of wine to his royal cellar at Isenhamstead. This points to the presence of a substantial manor house, probably built in stone, with substantial cellarage. A second document, cited by the antiquarian Daniel Lysons, refers to a royal

visit to Chenies before Easter of 1290. The Royal Court moved to Chenies from King's Langley on the 15th of March, and accounts survive for the hiring of carts to carry the luggage, which included a cask of ale. The accounts for the visit include details of food purchased (including large quantities of fish, bread and apples during the Lenten period). A blacksmith was brought in to overhaul the locks and keys, including the gate, suggesting that the manor lay within a precinct. The expenses included 10d worth of barley bought for a camel accompanying the royal party. The accounts list the preparations of the Easter feast in detail, and mention the boiling of 450 eggs for distribution to the locals.

- 1.3.10 The manor was once more back in the hands of the Cheyne family shortly afterwards, with Bartholemew Cheyne in possession between 1296 and 1316. It passed to his son Alexander, who was in possession when the name of Isenhampstead Chenies is first used in 1321. He was still holding it in 1346, but by 1350 it had passed to his son Sir John Cheyne. Sir John was Sheriff of Buckinghamshire and Bedfordshire in 1371, and a knight of the shire in 1373. He fell from grace in 1397, when he was condemned to death as a Lollard. His sentence was commuted to life imprisonment. (VCH, 1923, 200)
- 1.3.11 The earliest surviving element of the current building complex is the Medieval undercroft of an earlier manor house located beneath the current west range. This is a Scheduled Monument (Scheduled Monument 27145). Estimates of the date of this structure range from the 13th century (Pevsner, 1994) to the 15th or early 16th century (Foyle, pers. comm.). The National Monument Record (NMR 395208) suggests that the undercroft belonged to the 14th century manor house.
- 1.3.12 John Cheyne, the next owner of Chenies, married Agnes de Cogenhoe in about 1400. He was a Member of Parliament in 1413 and 1425, and was sheriff in 1426 and 1430. Agnes died, and John Cheyne obtained dispensation to remarry – Isabel Mortimer – in 1421.
- 1.3.13 John and his son Alexander conveyed the estate to one Thomas Cheyne, of another branch of the family. It passed from him to his brother, Sir John Cheyne, who was lord of Drayton Beauchamp. He died without issue in 1868, leaving the Manor to his widow, who married again – to Edmund Molyneux, who was sheriff of the county in 1475. He also predeceased her. She died in 1498, and in her will, she left the manor at Chenies to her niece, Anne Philip. She took possession of the manor in 1500, and on her death in 1510, it passed to her granddaughter, Ann Sapcote. Her first husband, John Broughton, died in 1518, and she remarried in 1526 – to one John Russell.
- 1.3.14 John Russell was a rising star at the court of Henry VIII. By the time of his marriage to Anne, he had been knighted, fought in the war in France in 1513 and undertaken diplomatic errands on Henry's behalf. He was with Henry at

the Field of the Cloth of Gold in 1520, subsequently lost his right eye at the siege of Morlaix in 1522. He was made knight marshal of the royal household, and undertook a number of secret missions on behalf of Henry VIII, including conducting negotiations with Charles, Duke of Bourbon, who was ready to betray the French king, Francis I. In 1524 he undertook negotiations with Pope Clement VII in Rome, and was present at the battle of Pavia in the following year. In 1527 he was sent as ambassador to Clement, who also employed him as a negotiator. He became Member of Parliament for Buckingham in the parliament of 1529 and took an active part in suppressing the Pilgrimage of Grace in 1536.

- 1.3.15 He was appointed the comptroller of the king's household in 1537, made a privy councillor in 1538 and then Lord High Admiral, High Steward of the Duchy of Cornwall and a knight of the garter. In March of 1539 he was created Baron Russell of Chenies, and in 1542 became high steward of the University of Oxford, and Keeper of the Privy Seal. In 1545 he was granted command of an army in the west of England, and was one of the executors of Henry VIII's will upon his death in 1547. He continued to serve the crown under Edward VI, and campaigned against the Devonshire rebellion of 1549, winning a decisive victory at Clyst St Mary near Exeter. In January of 1550 he was created Earl of Bedford.
- 1.3.16 Upon the death of Edward VI, he openly opposed the proposal to seat Lady Jane Grey on the throne; supporting Queen Mary, who reappointed him lord privy seal. He died in London in March 1555. For much of his life he had held positions of power and responsibility, and had ensured that he left his descendants wealthy and landed.
- 1.3.17 John Russell and Anne chose Chenies as their main residence - it had been recently modernised and lay close to Windsor and London. Much of the surviving south wing of Chenies Manor was probably built during his ownership. The majority of sources examined suggest that the remains of the current Manor House date between the late 15th century and the mid-16th century. The current west wing is thought to be the earlier of the two, probably dating to the late 15th century (NMR 395208), whilst the south wing is generally regarded as having been added in around 1530 by John Russell (NMR 395208). Chenies Manor is Listed Grade I.
- 1.3.18 Henry VIII first visited Chenies Manor in 1534, with Anne Boleyn and Princess Elizabeth. They stayed for a week, during which time the King received an agent sent by the King's governor at Calais. He was probably at Chenies on the 6th of July when he heard of the execution of Sir Thomas More. The King no doubt took the opportunity whilst at Chenies to hunt in the two parks belonging to the manor. The royal party left Chenies on the 10th of July, accompanied by Sir John Russell.

- 1.3.19 Henry visited the house once more in 1541, this time with Kathryn Howard, and the house was cited in her trial for treason as being the location of one of her trysts with Thomas Culpepper. The royal party arrived at Chenies on the 25th of October. A Privy Council meeting was held on that day, and attended by numerous dignitaries including the Bishop of Winchester, the Controller of the Royal Household, the Vice Chamberlain, the Master of the Horse and the Secretary of the Privy Council.
- 1.3.20 Chenies Manor is mentioned in Sir John Leland's Itinerary. Leland's visit to the house probably dates to 1544, and formed part of his north eastern Itinerary (Chandler 1993, xxx – xxxii). In his Itinerary, he describes the house at Chenies as:
- "The old house of Cheynies is so translated by my Lord Russell that little or nothing of it in a manner remaineth untranslated: and a great deal of the house has been newly set up made of brick and timber: and fair lodgings be new erected in the garden. The house is within diverse places richly painted with antique works of white and black"*.
- 1.3.21 Although no traces of these now remain, cartographic evidence suggests that there were two hunting parks at Chenies. Leland mentions two parks attached to the manor. These may have lain to the west and south west of the manor house (NMR Record 39522). A rental of the manor in the possession of Elizabeth McCleod Matthews, dated to 1571, describes *"the two parkes, the one called the olde parke cont(aining) by estimacon 484 ac(re)s whereof in wood the acres rental"*. The rental goes on to describe other parcels of land rented out, including a hopyard, and several closes and meadows.
- 1.3.22 John Russell was succeeded as Earl of Bedford by his son Francis. He had campaigned alongside his father in France, and had been Member of Parliament for Buckinghamshire from 1547 to 1552. Unlike his father, he supported the reformers, as a result of which he was imprisoned during the early years of Mary's reign, and then spent time in exile in Italy, fighting at the battle of St Quentin in 1557. He saw a degree of favour in the latter years of Mary's reign, being made lord-lieutenant of the counties of Devon, Cornwall and Dorset early in 1558.
- 1.3.23 The accession of Elizabeth to the throne saw him returning to court life. He was made a privy councillor, and undertook diplomatic missions to Charles IX of France and Mary Queen of Scots. Between 1564 and 1567 he held the post of governor of Berwick and warden of the east marches of Scotland. In 1576 he was president of the council of Wales, and in 1581 was one of the commissioners appointed to arrange a marriage between Elizabeth and Francis, duke of Anjou. He died in London in July 1585, of gangrene. Three of his four sons predeceased him, and he was succeeded as 3rd Earl of Bedford by his grandson, Edward Russell.

- 1.3.24 Elizabeth I spent four weeks at Chenies in July and August of 1570. Such royal visits required meticulous planning, and records survive suggesting that a surveyor visited the house in order to establish what work was required to bring it up to a suitable standard. This work included the construction of new cupboards to accommodate the royal wardrobe, repairs to doors, stairs and the woodwork, possibly including floorboards. William White, a glazier, was hired to install some 18 ft² of glass in the room the Queen was to occupy. The court arrived at Chenies on the 18th of July, and the Queen was accompanied by members of the Privy Council. These included the Earl of Leicester, Sir William Cecil, Lord Howard Effingham, the Earl of Lincoln and Sir James Crofts. Whilst at Chenies, the Queen received many visitors, including John Hawkins - her naval advisor – and a number of visiting ambassadors. The court departed Chenies on the 17th of August. The records of the Royal Wardrobe detail the loss of some of her personal finery:

“Item. Lost from the face of a gown in wearing the same, at Chenies, July.... One pair of small aglets, enamelled blue, parcel of 184 pairs” (transcription held by Elizabeth McCleod Matthews)

- 1.3.25 Francis’ debts at the time of his death in 1585 were such that they exceeded all of the money available and as a result of this it was necessary to reduce expenditure on Chenies Manor and for all goods not required by his widow to be sold to pay their debts. An inventory of the buildings and contents at Chenies was drawn up, listing nine bedrooms of consequence, three kitchens, a buttery, a ewery, a bolting house and woodsheds. The armoury for the house contained sufficient weaponry to equip 50 men. There were numerous outbuildings including two single storey ranges detached from the main buildings. These contained rooms for storage and for servants’ accommodation. After this the house went into the gradual decline. The dowager countess died at Woburn in 1601, and her will mentioned that the house at Chenies was still maintained in a good state, although it was more or less unfurnished and vacant.
- 1.3.26 The 3rd Earl of Bedford, Edward Russell, was involved in the Essex area rebellion against Elizabeth. As a result of this he was fined £10,000 and placed under house arrest at Chenies. His wife joined him at Chenies, and amongst her visitors was the poet and author John Donne. With the accession of James I to the throne the Countess of Bedford was made Lady of the Bedchamber for Queen Anne, and had to leave for Edinburgh. This marked a change in the Russell's fortunes and Chenies was once more occupied. However, the house was not occupied for long, and the family quit Chenies for good in 1608. The house was occupied by a Mr Vernon, who had been an employee of the estate for some time, until his death in 1622. A female housekeeper was employed, and allowed to make money from the gardens and orchards. The 3rd Earl died in 1627, leaving no children, and the title passed to his cousin.
- 1.3.27 Francis Russell, the 4th Earl of Bedford, had been the Member of Parliament for Lyme Regis and in 1623 he was made Lord-Lieutenant of Devonshire. He

was heavily involved in the growing conflict between King and Parliament, and in 1629 was arrested for circulating a pamphlet written by Sir Robert Dudley entitled '*Proposition for His Majesty's Service*'. He was soon released, and was one of the main opponents to the King at the Short Parliament held in April 1640. He had strong reservations about the plan to invite a Scots army into England, and in the following September urged Charles I to call a parliament, to make peace with the Scots. When the Long Parliament met in November of 1640, Bedford was seen as one of the leaders of the Parliamentary cause. He died of smallpox on the 9th of May 1641.

1.3.28 He was succeeded by his son, William, the 5th Earl of Bedford, who fought first on the side of the parliament and then on that of the king during the Civil War. In 1694 he was created Marquess of Tavistock and the 1st Duke of Bedford. Chenies was garrisoned by the Parliamentarian forces during English Civil War, during which time the Medieval undercroft may have served as a prison, as some of the graffiti inscribed on its walls is thought likely to relate to this period. The 1st Duke of Bedford died in 1700, and was succeeded by his grandson Wriothesley. He was succeeded in turn by his eldest son, another Wriothesley, in 1711. The 3rd Duke died in 1732, with no direct heirs, and the title passed to his brother, John.

1.3.29 In 1728 the west wing of the current house was let as a farmhouse to Mr Henry Blythe, at a rent of £23 per annum. The south wing remained largely empty and suffered from weather damage. In 1735 the family steward at Chenies reported:

“Chenies Place is a very large old house, brick built with some very large and lofty rooms, but the apartments are not very regular and of no more value than to be pulled down. There is a great deal of lead and other materials that would be very useful to repair a small box. It joins to the churchyard ”

1.3.30 Horace Walpole visited the house at Chenies on the 28th of September 1749. By this time much of the complex was in a sorry state of repair. He talks of the house being built around three sides of a court, falling down in places and with some of the roofs missing, although he does comment favourably on some of the stained-glass. He notes that the property reminds him of his visit to Sissinghurst in Kent, except that Chenies was the more ruinous of the two. A glazier was sent to the manor in the following year to remove much of the surviving stained glass, except for the one bearing the Russell's arms.

1.3.31 A letter surviving in the archives owned by Elizabeth McCleod Matthews dated to 1746 describes the difficulty caused by the window tax. In it, the steward, Robert Harris, lists the number of windows in the 'great house':

*“The uninhabited part hath about 54.
In the apartment I live in 34.
Mr Davies hath 28.*

As to the 54 they may all be stopped up except 4 or 5, which rooms we lay up the old materials. But I would hope the Parliament hath made a provision for empty houses.

Out of the 34 in my apartment, I can spare 12 or 14. I shall be glad to have your advice whether close lathing will not be sufficient, without plastering, for there is some very large windows which will be considerable charge, especially if the whole empty house is to be stopped up”

- 1.3.32 The iniquity of the window tax may have played a significant part in the decision to dismantle or abandon some of the buildings within the complex.
- 1.3.33 In 1760 the south range was divided into five tenements for farm labourers, with new doors inserted and an extra staircase added. The steward in residence advised that the building be pulled down, a request refused by the 7th Duke. Instead, he embarked upon a restoration programme, inserting new window frames and rebuilding some of the west range. He visited the estate in July 1808: it was then a farm of some 300 acres.
- 1.3.34 Substantial repairs were carried out to the surviving elements of the manor house in c. 1830, following occupation of an unreliable tenant (NMR 395208). These were undertaken by the architect Edward Blore (who also worked on St James’ Palace and Buckingham Palace) for Lord Wriothelsey Russell. In 1840 an old Tudor building attached to the west wing was taken down and replaced with a new structure. Two bay windows were added to the west of the house in 1860 and the brewhouse was demolished. The house remained in the ownership of the Russell family until bought by the present owners in the late 1950’s.

1.4 Previous Archaeological Investigations

- 1.4.1 The manor house at Chenies has been subject to little previous archaeological work. The main exception to this is an historic building survey and watching brief undertaken during work on the building known as The Old Nursery by Hertfordshire Archaeological Trust (HAT, 2000)
- 1.4.2 The Old Nursery comprises the remains of a small L shaped building to the west of the main manor house (shown on Figure 2). At the time of the building programme (designed to convert the standing remains to form a visitor centre), the structure was missing its north west façade, but the majority of the walls stood to more or less their original height (HAT, 2000, 3).
- 1.4.3 The historic building survey indicated that the standing remains were the remains of a building constructed during the early 16th century remodelling of the old house. It also suggested that this building probably represents the ‘fair loggines’ in the garden described as newly built by John Leland at the time of his visit, and which may also have housed William Cecil, Chancellor

to Elizabeth I, who required a quiet lodging when the queen visited Chenies in 1570. The use of crow-stepped gables, expensive brick and fine fireplaces are cited as evidence of the importance and status of the building (HAT, 2000, 12)

- 1.4.4 The lower floor was considered more functional, with both a bread oven and a cellar (with unusual niches built into the walls), whilst the upper floor was more ostentatious. It was lit by a number of large windows on the north side. The survey also suggests that the building may have served more than one purpose, including as guest lodgings and as a pavilion or banqueting house located between the privy gardens to the south and the 'great' garden to the north.

2 METHODS

2.1 Introduction

2.1.1 A project design for the work was compiled and provided by Videotext Communications Ltd (Videotext Communications 2004). This contains a detailed description of the research aims of the project, as well as the methodologies to be employed in achieving these aims, and these are only reproduced in summary here. The archaeological works undertaken as part of the programme comprised geophysical survey, archaeological trial trenching and a programme of dendrochronological dating on the timbers of the surviving building ranges.

2.2 Aims and objectives

Trial Trenching

2.2.1 The stated aim of this project was to ascertain the character, extent and degree of preservation of the archaeological remains at Chenies Manor (Videotext Communications, 2004, 4). The project offered the opportunity to use a number of archaeological techniques to examine the complex history of Chenies Manor, which, during the Tudor period, was a more substantial complex than is evident in the current buildings. It also offered the chance to add to the knowledge gleaned from the extensive documentary sources relating to Chenies Manor, with the aim of adding a greater depth of understanding to the site. The two main aims identified in the Project Design (Videotext Communications, 2004, 4) for the work were:

- To characterise the archaeological resource at the site, and
- To provide a condition survey of those parts of the site investigated

2.2.2 The archaeological work at Chenies was predominantly intended to examine the evidence for the Tudor history of the site, and in particular with the transformation and remodelling of the inherited Medieval manor by John Russell, into a house fit for the visits of King Henry VIII. The house as it stands is clearly not large enough to have housed the King and his vast retinue, and the documentary sources mention additional ranges of buildings to those that survive today. The location of these Tudor remains and structures is unclear, and the project sought to shed further light on the extent and nature of the Tudor manor in its heyday. The results of this work could form an important resource for the future management and interpretation of the site.

2.2.3 In order to meet these aims, a number of specific locations were suggested as worthy of archaeological investigation:

- In the modern entranceway to the manor across the gravel driveway to the east, to identify/confirm the presence of a possible gate house structure or range of buildings along the east side of the courtyard, linking the present south range with the east end of the presumed north range.
- In the narrow alley running north south between the western wall of the churchyard of St. Michael's church and the current east wall of the manor house. The northern half of the west wall of the churchyard is built of Tudor brick, and contains the remains of a Tudor style fireplace against its western face. This is similar to those surviving in the present southern wing of the manor. This may represent the remains of a north range of similar size and date to the current south range. It has also been suggested that the Tudor buildings extended into the current churchyard, and this possibility could also be investigated.
- Close to the possible site of the Medieval great hall, where a 14th or 15th century undercroft survives. It is possible that the earlier Medieval and later Tudor Great Hall, which no longer survive, lay to the south of this undercroft, in the area occupied by the modern kitchen. The undercroft is a Scheduled Monument (SM 27145) and the oldest structure on the site. It was not possible to excavate within or close to this structure, but the results of nearby trenches might help establish the role played by this structure within the overall development of the manor complex.
- The garden behind the southern range of the manor, in the search for the missing range of buildings which is referred to in documentary sources and which appears to be recorded in an 18th century watercolour kept at Chenies Manor. The date of this range of buildings may well reflect the Tudor expansion with which this project is primarily concerned. However, these buildings are equally likely to be associated with the expansion of the farm in the 18th century.
- The area immediately around the building now known as 'the pavilion', which may once have been part of a larger structure.
- In the area of a raised earthwork structure visible in the gardens south of the existing south range.

2.2.4 In addition to these, further areas of interest would be identified through the geophysical survey and as the result of the archaeological evaluation.

Geophysics Survey (by GSB Prospection Limited).

2.2.5 A detailed report on the Geophysics survey has been prepared by GSB Prospection Limited, and forms part of the site archive (GSB, 2004). Its aims and objectives are included here in summary form. A total of six areas (Figures 3 and 4) were surveyed using ground penetrating radar (GPR) and/or resistance according to the ground conditions. The main aim of this survey was to try to find evidence for the size and nature of the original Tudor manor, as well as to identify other buried features of possible archaeological interest. Conditions for survey were generally favourable,

with a combination of level lawns, gravel paths/driveways and concrete surfaces. Survey was only complicated in some areas due to the small survey size, the shape of the lawns and the gravel paths; in one area these were laid out to form a small maze.

Dendrochronology (by Michael Worthington and Daniel Miles).

- 2.2.6 Dendrochronology work on the site was undertaken by Michael Worthington and Daniel Miles of the Oxford Dendrochronology Laboratory. Samples for tree-ring dating were taken from 26 structural timbers in the south and west ranges of Chenies Manor, with the aim of clarifying the dates of the existing structures. A detailed report on this dating can be found in the project archive (Worthington and Miles, 2004).
- 2.2.7 The dendrochronology samples were taken using a 16mm hollow auger powered by an electric drill and were sanded on a linisher using 60 to 1000 grit abrasive paper. These were then measured to an accuracy of 0.01mm using a travelling stage attached to a microcomputer-based measuring system (Reynolds *pers comm* 1998).
- 2.2.8 The samples were compared with each other using dendrochronological techniques as outlined by English Heritage (1998). This involved both visual comparisons using semi-logarithmic graphs as well as statistical cross-correlations using a computer. This utilised cross-correlation algorithms (Baillie and Pilcher 1973) which have been implemented using computer software written for Windows in Visual Basic by M R Allwright and P A Parker. In comparing two individual samples, a t -value of 3.5 or higher is usually indicative of a good match, whilst t -values of 10 and above often suggest that samples have originated from the same parent tree. All individual samples showing a match with consistently high correlation during cross-matching are averaged together to form a mean site master. On comparing this site master with dated reference chronologies, t -values of 5 and above are normally expected. A conclusive match should usually exhibit the highest matches with reference chronologies of local origin as well as with well-replicated regional chronologies, unless the timber was imported. Matching positions suggested by computer are confirmed by satisfactory visual matching.
- 2.2.9 Once a ring sequence has been dated chronologically, the date of felling needs to be interpreted. When the sapwood is complete on a sample, the determination of a felling date is relatively straight-forward. Each growth ring is comprised of one or more rows of open spring vessels, or early wood, followed by a band of dense summer growth or late-wood. During the winter months the tree remains dormant. If both the spring and summer growth are present and complete, then the tree would have been felled during the winter period. If only the spring vessels are present beneath the bark, then the tree can be said to have died or been felled during the spring period. If only a few vessels are present, then it is possible to further refine the time of felling to

early spring. If some dense wood or summer growth is present, then a summer or autumn felling period can be determined. However, as it is not known how wide the summer growth band should be for that particular tree, it cannot be stated conclusively whether the tree was felled in early or late summer, or if indeed it was felled at some point in the winter. For instance, a severe May frost can suddenly halt the tree's growth, which would produce a very narrow ring with little or no summer wood (Baillie 1982, plate 2c). Therefore, a certain degree of caution should be used in interpreting felling seasons between summer and autumn, or even winter seasons in some instances. Only apparently complete rings indicating felling during the winter months are measured, samples exhibiting spring or summer growth give a felling date during the year following the last measured ring.

- 2.2.10 If the outermost rings are missing but the heartwood-sapwood boundary survives, then the number of missing sapwood rings can be estimated using an empirically derived sapwood estimate. The sapwood estimate used in this report is 11 to 41 rings, the 95% confidence range calculated by Miles (1997) for Shropshire.
- 2.2.11 It should be remembered that dendrochronology can only date when the tree died, not the date of construction for a building or artefact. The interpretation of a felling date relies on having a good number of precise felling dates rather than just one or two. Nevertheless, it was common practice to build timber-framed structures with green or unseasoned timber and construction usually took place within twelve months of felling (Miles 1997).

2.3 Fieldwork methods

- 2.3.1 Ten trenches were excavated by machine in the environs of Chenies Manor, with a further eight excavated by hand (Figure 5). The size of these trenches varied in length and width according to their location and purpose. The location of the trenches was determined by Mick Aston in consultation with associated specialists and guided by the results of the geophysical survey in order to answer specific aims and objectives of the project design.
- 2.3.2 Where appropriate, trenches were excavated using a small tracked 360° mechanical excavator fitted with a toothless ditching bucket. All machine work was undertaken under constant archaeological supervision and ceased at the identification of significant archaeological deposits, or where natural deposits were encountered. All trenches were subsequently cleaned by hand and archaeological deposits were planned, recorded and representative samples excavated by hand.
- 2.3.3 All archaeological deposits were recorded using Wessex Archaeology's *pro forma* recording sheets with a unique numbering system for individual contexts, drawings and samples. Trenches were located using a Trimble Real Time Differential GPS survey system. All archaeological features and

deposits were planned at 1:20, and all sections were drawn at 1:10. All features and deposits were photographed, using both digital and manual cameras (black and white and colour slide). All principal strata and features were related to Ordnance Survey datum and a photographic record of the investigations and individual features was maintained.

- 2.3.4 A sufficient sample of all deposits was examined to allow the resolution of the principal questions outlined in the aims and objectives above. Other deposits were recorded and preserved *in situ* but not excavated.
- 2.3.5 The work was carried out over 16th-18th March, 2004. All spoil was metal detected by recommended local metal detectorists. At the completion of the work all trenches were reinstated using the excavated spoil from the trenches and the turf relain.

3 RESULTS

3.1 Introduction

- 3.1.1 Details of individual excavated contexts and features, and results of artefact analysis are retained in archive.

3.2 Geophysical survey (by GSB Propection Limited)

Ground penetrating radar survey (Figure 3)

- 3.2.1 The results of the ground penetrating radar survey in Area 1 are dominated by linear responses (1) and (2). The alignment of these is similar to the existing wings of the manor house and therefore they are believed to represent walls or footings. In the area between (1) and (2) the responses appear slightly stronger, possibly indicating the presence of a buried surface. Linear anomaly (3), which ran roughly perpendicular to linear anomaly 1, also appeared to represent an archaeological feature.
- 3.2.2 A number of other anomalies with archaeological potential were also identified, perhaps relating to associated structures but any firm interpretation was not possible. One anomaly highlighted for further investigation was the strong circular response (4). It was felt that this could be the position of a courtyard well and a distinct dipping reflector, visible in the radargrams, may have been some form of culvert or pipe running in to it.
- 3.2.3 Area 2 comprised the walled garden to the north of the courtyard. Two areas were investigated in this part of the garden, the first of which, 2A, was a strip 3.0 metres by 10.0m along the northern side of the garden's southern boundary wall. This area revealed nothing of archaeological potential. The second area, 2B, also revealed only a small amount of detail. A slight trend

was noticeable between the quiet area to the north and the slightly more disturbed area to the south. It was coincident with the break of slope and thus probably highlights some form of landscaping. The high amplitude response in the south west, although right at the edge of the survey area may be significant as excavations to the west revealed the front of the original manor house in a similar orientation and it is feasible that the remains extend this far.

- 3.2.4 The ground penetrating radar survey in Area 3 was purely exploratory, and undertaken to determine the likelihood of structures extending out from the southern side of the house and into the field beyond. Although there are two linear features visible within the data set, the acute angle between them suggests that these are unlikely to be building remains. Also, given that there appear to be buried surfaces adjacent to the linears, it seems plausible that this area has been landscaped and that these represent either old walls/garden features or some form of drainage.
- 3.2.5 In Area 4A, a great deal of noise (5) is noticeable, bound to the south by a linear trend (6). To the east this noise is apparent through most of the section and is confined to the route of the current driveway. It is thought that the responses (5) and (6) represent the old route of the driveway and a border or kerb. The deepest slices (from approximately 0.8m onward) highlight response (7) from part of the undercroft, which is thought to have been built as part of the Medieval manor house. A mass of rectilinear responses (8), (9) and (10) are believed to represent features relating to the structure of the manor house, the front of which was found in excavations immediately to the north. Although difficult to make out in the time-slices, (10) is still visible beneath the disturbance (5) when viewed in section. A faint linear anomaly (11) is thought to be a service route of some description. This could be significant, as it appears to be running into anomaly (12), originally thought to be part of the manor remains. However, given the position of (11) and the fact that (12) aligns with anomaly (14), which looks like a service running through Area 4C, this now seems less likely.
- 3.2.6 The survey in Area 4B was conducted almost totally within a large metal-framed barn, which can cause problems with radar energy reflected from the structure and masking buried features. This does not appear to have been too much of an issue and a region of high amplitude response (13) has been identified as being of possible interest, in relation to the manor. Within the radargrams there appears to be a well defined surface in the southern half of the traverses which then gives way to more isolated responses. Whilst these features may be a facet of the concrete floor of the barn and any possible hardcore dumped beneath it, an archaeological interpretation certainly cannot be ignored given the proximity of the remains uncovered immediately to the east.

3.2.7 Area 4C has a number of anomalies which, initially, could be seen to relate to possible manor house remains, though it has been possible to eliminate some of them. In the radargrams, (14) shows a response typical of a service or pipeline, and thus maybe a drain or similar. Immediately to the north of this is a high amplitude response, again noticeable within the radargrams, which is coincident with a change in the concrete surface as the traverses enter a courtyard. The northernmost anomaly, cutting across the area, lies directly between two access covers and is probably a service pipe between them. This leaves one potential area in the northern half of the survey area (15), which is not particularly obvious within the radargrams and thus remains tentative, and one in the southern half (16). At the time of the survey, a service locator was used and (16) was said to be the effect of a number of services coinciding at that point. However, given the response in the radargrams, it still seems likely that there is some form of structural remains here, thus it may be that the services are adjacent to an archaeological feature, increasing the response. This, however, remains a cautious interpretation.

Resistivity survey (Figure 4)

- 3.2.8 In Area 1, high resistance anomaly (R1) coincides with GPR anomaly (1) which proved on excavation to be brick wall foundations of Tudor date. It is interesting to note that in the western half of the lawn, the resistance readings associated with this wall are higher compared to elsewhere, yet the radar reflections are less clear at this point. It would seem that where several courses of brick foundations were surviving very near to the ground surface these were not detected by the resistance technique; presumably due to the fact the Tudor bricks had a high moisture content. As a consequence, the 'picture' of any foundations visible in the resistance data is clearly incomplete. High resistance along the edge of the western and north-western edges of the survey grid coincide with a gravel path and tree roots.
- 3.2.9 The results from Area 2 are confused by two gravel paths and a 'maze' arrangement in the vegetation. The ground had clearly been disturbed in the recent past – evidence of old trenches was still visible – and as a result there is nothing in the resistance data thought to be of archaeological interest.
- 3.2.10 As discussed earlier, the aim of the survey in Area 3 was to determine whether there were originally adjuncts of the building extending outwards in the south-western corner. Although the results are confused by landscaping and services, the resistance data do in fact display some high readings (R2) that have an element of a rectilinear form that may well be structural. However, the results are far from conclusive; excavation would be required to verify this suggestion.
- 3.2.11 Area 5 - a small paddock - was surveyed in an attempt to locate a putative gate-house structure and a road leading into the Tudor complex. A service main crosses the area but high readings (R3) could indicate the gatehouse

while the readings (R4) in the north could indicate the road. Unfortunately no remains were identified in this area during the trial trenching which might further explain these results. In the light of this, the interpretation of the geophysics remains inconclusive.

- 3.2.12 Area 6 was surveyed in an attempt to locate a putative eastern wing extending north of the southern wing of the surviving house. However, the results are totally disturbed by modern services and an existing road.

3.3 Dendrochronology (by Michael Worthington and Daniel Miles)

The West Range

- 3.3.1 Five samples were taken from the roof over the south block in the west range. Three of these provided precise felling dates ranging from spring 1537 to summer 1538. Timbers dated included a queen strut, tiebeam, and rafter. Four other samples were taken from the northern block of the west range. Although these did not have complete sapwood surviving, the date ranges of 1515-47, 1517-49, and 1518-50 are consistent with the 1537 and 1538 felling dates and the two ranges are probably broadly contemporary. Their roof structure is very similar, both incorporating an integral ceiling constructed of axial binders tenoned into the tiebeams carrying framed ceiling joists, indicating that these two blocks were ceiled from the outset. No evidence could be found for the smoke-blackened timbers in this range mentioned in a 1982 Country Life article, and the presence of an original framed ceiling would naturally preclude any soot deposits in the roof.

The South Range

- 3.3.2 Ten timbers were sampled in the Long Gallery in the south range, two samples from the ceiling of the Long Room on the ground floor, as well as the west strut from the east chimneystack. Seven precise felling dates were found for the Long Gallery roof ranging from spring 1547 to spring 1552. Timbers dated included a purlin, principal and common rafters, a wall plate, and interrupted ties. Downstairs one transverse beam with heartwood/sapwood boundary gave a felling date range of 1540-72, proving that the structural timber-work is coeval throughout the range. The felling dates suggest that the south range was constructed during 1552 or very shortly afterwards. The construction of the Long Gallery and the south range as a whole is of interest in that both major floor-frames are composed of transverse beams with tall thin joists more commonly seen after 1600. The earliest previously-known example of similar floor construction was from c. 1562 (datestone) at 6-7 Canonbury Place, Islington, although the Wolsey kitchen at Hampton Court has some undated tall thin ceiling joists which are thought to be original (Richard Bond *pers comm*). Nevertheless, the south range at Chenies is probably the earliest firmly-dated example of this type of carpentry.

- 3.3.3 A single sample from the west strut of the truss in the east chimney stack of the south range did not date.
- 3.3.4 Both the north block of the west range as well as the roof timbers in the Long Gallery had remains of red ochre-painted assembly marks, an unusual feature.

The Linking Block

- 3.3.5 Three samples were taken from the Upper Gallery in the linking block between the south range to the staircase tower in the west range. Two of these, a tie-beam and a purlin, dated, but the sapwood broke up on both timbers. Nevertheless, taking into account the detached sections of sapwood, felling date ranges of 1538-61 and 1550-80 were given for these two timbers respectively. This suggests that the Upper Gallery was constructed either at the same time as south range, although a case could be made for it having been part of the west range of 1537-8, and modified when the 1552 Long Gallery with constructed.

3.4 Archaeological Evaluation

- 3.4.1 Eighteen trenches were excavated during the course of the evaluation (Figure 5). These were targeted either on areas identified in the project design, or on areas identified during the course of the exercise, largely through the geophysical survey. They were excavated to the east, north and west of the current house.

Trench 1 (Figure 6)

- 3.4.2 Trench 1 measured some 4.70m by 1.40m. It was positioned at the eastern end of the south range of the manor house. A vertical scar visible in the brickwork of the northern wall of this range at this point suggests the presence of a wall or range of buildings, now demolished, running to the north towards the edge of the churchyard. This Trench was excavated in order to establish whether any remains of such a structure still survived.
- 3.4.3 Topsoil (101) and a subsoil (102) were removed to reveal a layer of dumped material (103). This probably represents a levelling layer. In the south west corner of the Trench it overlay a crude mortar surface (104). This comprised a thin spread of mortar lain on a bed of broken and crushed tile. Only a small patch of the surface was revealed, and its exact purpose, extent and date are unclear. It occurs fairly late in the sequence, however, and may represent a crude working surface associated with one of the Post-medieval or Victorian phases of repair work. Anthropogenic material recovered from the subsoil (102) included sherds of 17th and 18th century pottery.
- 3.4.4 Layer 104 sealed a layer of demolition rubble stretching across the full extent of the trench (105). This contained a high proportion of building rubble

including brick, mortar and tile, as well as sherds of 18th century and modern pottery. This demolition material sealed a number of archaeological features and deposits of which the latest was wall 106. This wall foundation, of unfrosted bricks laid in a yellow cement mortar, was 0.80m wide and aligned roughly north-south. This poorly formed foundation is unlikely to have supported a substantial structure. Layer 105 also sealed a second wall aligned roughly west east (107). This wall was built of flints laid in a yellow cementitious mortar. The full width of this wall could not be fully determined, as its southern edge was truncated by a modern pipe trench containing an electricity cable (117). Pottery recovered from layer 115, the fill of 117, dated to the Post-medieval and modern periods. Towards the eastern end of the trench, wall 107 was also cut by a further modern trench (119), containing a plastic water pipe (118). In contrast to wall 106, wall 107 was well made, with tiles occasionally used to keep the flints evenly coursed. The flints themselves were knapped to provide a relatively even face to the wall. The foundation trench for wall 107, (111), cut through the earliest recorded archaeological phase within the trench. This early phase comprised a wall (108), aligned roughly north-south, with associated layers of cobbling (109) and a probable garden soil (112).

- 3.4.5 Wall 108 took the form of a heavily truncated foundation, 0/80m wide, of red handmade unfrosted bricks laid in a white lime mortar matrix. No coursing was apparent, although given the nature of the truncation, this is hardly surprising. The wall was cut by 106 to the north, 111 to the south and also by modern electricity trench 117. Traces of this foundation could be seen in the southernmost section of the trench, to the south of cut 117, and it is clear that originally the foundation extended further to the south. Wall 108 was butted to the west by layer 109, a thick layer of compacted gravel, probably laid for use as a yard surface. To the east of the wall lay layer 112. This layer probably represents a build up of garden soil, and contained few anthropogenic components.
- 3.4.6 It is thought likely that wall 108 represents a Tudor or early Post-medieval wall, probably delineating the eastern edge of the courtyard of which the surviving buildings formed the southern and western sides. Layer 109 probably represents one phase of the surfacing of this yard. Small investigative sondages established that both layers 109 and 112 directly overlay the natural drift geology (layer 113).

Trench 2 (Figure 7)

- 3.4.7 Trench 2 was targeted on two linear anomalies identified during the geophysics survey of the garden within the courtyard of the present manor house (see Figure 3). The alignment of one of these anomalies, running approximately east west, was recognised as similar to the alignment of the existing south range, and this trench was excavated to establish whether this represented the remains of another range of the original Manor house, forming the northern range of the courtyard. Trench 2 measured some 4.5m by 3.1m, and was excavated to a maximum depth of 0.82m.

- 3.4.8 Topsoil (201) was removed to reveal the upper surface of a demolished brick foundation on this roughly east west alignment (204), corresponding with the geophysical anomaly. Material recovered from the topsoil included Post-medieval and modern pottery, as well as a single sherd of residual Early Bronze Age pottery. Wall 204 was butted by layers of demolition material. To the south of the wall, layer 202 was a relatively thick demolition deposit, and contained fragments of brick, tile, mortar and flint, probably derived from the demolition of wall 204. To the north of this wall lay demolition layer 203, which was very similar in nature to 202. This layer overlay a small modern posthole (214) containing the rotting remains of a wooden post.
- 3.4.9 Wall 204 itself was some 0.6m wide, and built of handmade unfrosted bricks laid in a yellow lime mortar matrix. No regular coursing was evident within three surviving courses, and much broken and reused brick was evident in this foundation. This wall was laid on a wider flint and mortar foundation (205). This comprised a substantial but crude foundation of flint nodules laid in a very hard light yellow lime mortar matrix. Many of these flints showed little or no sign of any working or shaping. The upper surface of this foundation, on which the wall 204 was built, was roughly levelled using a layer of reused roof tiles.
- 3.4.10 Construction cut 206, dug to contain wall 204 and flint foundation 205, was cut through layer 208, a garden soil to the north of wall 204. To the south of wall 204, layer 202 directly overlies the natural drift geology (209). No equivalent layer to layer 208 was identified, and this may have been removed either during construction or during demolition of the structure of which wall 204 formed the northern extent. Only half of layer 202 within the trench was completely excavated, with half left *in situ*. Two features were identified in this excavated area - posthole 210 and ditch 212. The first of these, posthole 210, was ovoid in form and contained a single fill (211). No anthropogenic material was recovered during the excavation of this fill, and the feature cannot be dated closely. Ditch 212 lay against the eastern baulk of the trench, and its full width could not be determined. It took the form of a linear cut aligned roughly north - south. An intervention excavated across this ditch revealed that the western edge was moderately steep and the base concave. The feature contained a single fill, layer 213 - a secondary fill from which no anthropogenic material was recovered. Ditch 212 continued to the north of wall 204, where it ran roughly parallel to a second ditch, ditch 217.
- 3.4.11 Ditch 217 is likely to have extended to the south of wall 204 beneath the unexcavated portion of 202. It was roughly v-shaped in profile, with moderately steep straight sides and a concave base. Although it was over 2m wide, this ditch was only 0.33m deep, and contained a single fill (216). This secondary fill, which accumulated slowly as a result of the erosion of the sides of the feature and the surrounding topsoil, contained a few small sherds of sandy and flint tempered pottery, dating to the 12th and 13th centuries AD.

Trench 3 (Figure 8)

- 3.4.12 Trench 3 lay to the north of the Manor house complex, and was excavated to investigate the steep edge of an artificial terrace. This terrace is thought likely to have been created as part of the formal gardens of the Tudor or Post-medieval manor house. The terrace edge slopes steeply down from north to south, and the remains of a wall stub protruding westwards from the wall surrounding the manor suggests that the terrace may have been associated with a brick wall, which may have acted as a retaining wall. Trench 3 was machine excavated, and measured some 4.72 m by 1.4m.
- 3.4.13 The topsoil (301) and colluvial subsoil (315) were removed to reveal a sequence of features and deposits cut into the natural drift geology (314). The remains of a retaining wall were excavated running roughly east north east to west south west across the trench. This wall (307) comprised a mortared flint core faced in brick. It was built in a steep sided construction cut (305), which was subsequently filled with a clean mid orange brown gravel (302). The full depth of this cut was not established. This wall probably acted as a revetment or retaining wall for the gardens to the south. Its date is unclear, although none of the bricks used was frogged, and it is thought most likely to represent a Tudor or Post-medieval garden feature.
- 3.4.14 Further down the slope, and parallel to wall 307 lay a gravel-filled drain. This Post-medieval or modern cut (309), containing substantial quantities of clean gravel was not fully excavated, and was assigned a single number. Both it and layer 308, a mid orange brown loam containing frequent chalk flecks, were sealed by a thin skim of mortar (layer 306). Layer 308 was also cut by a single small undated pit or posthole (312), which contained a single fill – layer 313.
- 3.4.15 At the northern end of the trench a thin lens of orange brown silt loam (303) sealed a dump of material (layer 304), which contained substantial quantities of demolition and waste material including brick, tile and burnt material. At the extreme northern end of the trench, layer 311 was also a dump of demolition debris, also containing brick and ceramic building material. This also contained significant quantities of burnt material. Many of these layers down slope of wall 307 may well represent dumps of material brought in to build up the terrace.

Trench 4

- 3.4.16 Trench 4 was a machine-excavated trench located just within the walled garden to the north west of the courtyard. The purpose of this trench was to establish whether any traces of a northern range survived in this area. Excavation revealed that the topsoil/gravel pathway (layer 401) sealed a thick dump of mixed material in the form of a mid brown sandy clay containing quantities of brick, tile and mortar (layer 402), from which a single sherd of residual flint tempered early Medieval pottery was recovered.

This in turn sealed the natural drift geology (layer 403). No significant archaeological deposits or features were identified.

Trench 5

- 3.4.17 Trench 5 was a small hand dug 'T' shaped trench to the west of Trench 1. It was some 2.2 m long and 1.2 m wide at its widest point and was excavated to examine the continuation of wall 107 identified in Trench 1, as well as to look for a second wall on the alignment of wall 108, which might indicate the presence of an eastern range. Excavation revealed that the gravel path (501) sealed the backfill of a modern service trench containing a cast iron service pipe, which had truncated any deposits in this area, and was cut into the natural sand (layer 503).

Trench 6 (Figure 9)

- 3.4.18 Trench 6 was a small hand dug trench, some 0.7m wide and 0.7 m long, excavated to examine the relationship between the wall identified in Trench 2 (204/205) and the wall currently forming the eastern boundary wall of the manor house. The garden topsoil (601) sealed a subsoil layer (602), which contained some demolition material. The wall forming the current boundary of the manor - wall 609 - is built in red brick, laid in a yellow mortar in an English Garden bond. This is built on stepped brick foundations. One of these bricks in the foundation is frogged, suggesting that the wall was probably built in the Victorian period.
- 3.4.19 Wall 609 was constructed within a steep sided linear cut (607). This clearly truncated the line of wall 606, which represented the continuation of wall 204 from Trench 2. Like wall 204 wall 609, was built of brick on a wider flint foundation. The brick coursing of the wall is random, with some reused and broken bricks. The foundation trench for this wall (604) cut subsoil layer 603. Because only a small area of layer 603 was exposed, it was unclear whether this represented the natural drift geology or not. It did, however, contain some charcoal flecking.

Trench 7 (Figure 10)

- 3.4.20 Trench 7 was a small hand dug trench excavated within the lawn within the courtyard. It measured some 1m by 1m. The topsoil (701) sealed a dump of gravel rich material (702). Post-medieval and modern pottery was recovered from these layers, along with a single residual sherd of flint-tempered pottery. Layer 702 was a poorly sorted deposit, and probably represents material brought in to level up the courtyard and provide hardstanding. As such it may have been laid in the Tudor or Post-medieval periods. This deposit in turn sealed the natural drift geology (703). It also sealed the cut of a small posthole (704). This sub-circular cut was 0.36m in diameter and 0.17m deep. It contained a single fill (705), a grey brown sandy silt.

Trench 8 (Figure 10)

- 3.4.21 Trench 8 was also a small hand-dug trench in the middle of the lawned area of the central courtyard. This was targeted on a linear geophysical anomaly. This anomaly was aligned roughly west-east, and parallel to that investigated in Trench 2. The topsoil (801) and subsoil (802) were removed, revealing a thin layer of mixed demolition material spread across the Trench (803). This almost certainly represented material derived from the demolition of wall 804, which it overlay. This wall lay directly on the line of the anomaly identified in the geophysics survey (see Figure 3). It was a substantial wall foundation, over 1m wide and built of handmade unfrogged bricks lain in a light yellow sandy lime mortar. Many of these bricks were broken or re-used. A thin spread of brick rubble in a mortar matrix indistinguishable from this foundation except for in its depth, extended to the south. This foundation lay within a steep sided cut (806/808 – the southern edge of this cut was numbered 808 and contained the thinner spread of mortared rubble). In this area to the south of the wall, the thin layer of mortared foundation sealed a thickish layer of material used to fill the construction cut. It is possible that this indicates that there may have been a room or structure to the south of wall 804, hence the difference in the nature of the construction cut. Pottery sherds recovered from this trench included a single sherd of glazed Post-medieval pottery from topsoil 801 and a sherd of residual flint tempered Medieval pottery dated to the 12th and 13th centuries recovered from 809, the fill of 808.

Trench 9

- 3.4.22 Trench 9 lay within the walled gardens to the north of the courtyard. It was 10m long, 1m wide and excavated by hand. It was targeted on an anomaly identified in the ground penetrating radar survey (see Figure 3). This linear anomaly was aligned roughly west-east. The turf and topsoil (layer 901) were removed by hand to reveal a mixed subsoil (layer 902) containing much demolition material. This was cut by obviously modern features, the fills of which contained modern rubbish, and which may have caused the geophysical anomaly. Pottery recovered from layer 902 dated to the Post-medieval and modern periods. It was decided not to investigate these deposits and features further. In the light of the presence of a geophysical anomaly at the southern end of this trench this decision now seems unfortunate.

Trench 10

- 3.4.23 Trench 10 was located against the south west corner of the modern churchyard wall. It was excavated by hand with the intention of examining the archaeological deposits in the area. The trench was 1m long and 0.6 m wide. The topsoil/gravel surface (layer 1001) was removed, along with a subsoil (layer 1002), which contained a high proportion of demolition material including brick, tile, mortar etc, as well as being heavily spell root disturbed. Much of this material was derived from layer 1003, a layer of crushed brick mortar and tile, which lay beneath the subsoil. This overlay a layer of heavy flint cobbling (layer 1004). The size of these cobbles and the

quality of the surface suggest that this is likely to represent a track or roadway rather than an area of hard standing. The Victorian churchyard wall itself (1007), built of squares of ashlar and flint laid in a checkerboard fashion, lies on a foundation of frogged bricks within cut 1005, which was cut directly through the subsoil (layer 1002).

Trench 11 (Figure 9)

- 3.4.24 Trench 11 was a small hand dug trench, measuring 1.1m by 0.9m. The purpose of this trench was to investigate the potential relationship between the western wall of the churchyard, which at this point is built of Tudor bricks, and then in a continuation of the wall identified in trenches 2 and 6.
- 3.4.25 The Modern path material (1101) and its make up and levelling layers (1102 and 1104) sealed a demolition layer, rich in ceramic building material (1103). Beneath this the foundations of the two walls were evident. The foundation of the churchyard wall (1105) was a stepped foundation of flints laid in a yellow lime mortar matrix. This lay within a cut (1106) which had steep sides and a flattish base. This clearly cut through the foundation of the roughly east west aligned wall (1007). Although this wall was heavily truncated and poorly preserved, it is certainly the same wall as identified in Trench 2 (204) and Trench 6 (606). This is potentially very significant, as it suggests that this wall continues into the churchyard. It also suggests that this stretch of churchyard wall, built using handmade Tudor bricks, and incorporating the remains of a fireplace on its western face, represents a later phase of construction.

Trench 12 (Figure 11)

- 3.4.26 Trench 12 lay to the north west of the current manor house in an area of hard standing at the eastern end of a range of modern agricultural barns. This was a large machine-excavated trench, measuring a maximum of 10.20m by 8.25m. The modern yard surface (1201) and hardcore levelling layer (1202) were removed by machine, revealing the palimpsest of archaeological features.
- 3.4.27 These archaeological features were dominated by the substantial remains of a Tudor or Post-medieval building. Because of the time constraints incumbent upon the evaluation exercise, it was not possible to fully establish the structural phasing of this complex. In the light of this, the phasing presented here should be regarded as provisional only, and has not been proven by excavation (See inset on figure 11).
- 3.4.28 There is little doubt that walls 1204 and 1222, and drain 1208 represent the first phases of brick construction. Of these, wall 1204 was built first, and runs from east north east to west south west. It was unclear after cleaning whether this was in fact two walls with the western stretch not extending beyond at the corner with wall 1222, with a narrower stretch continuing to

the east thereafter. It is clear that the eastern section of this wall was thickened at a later date, but it is less clear whether the wall to the west of 1222 was originally narrower and similarly thickened. Much of the upper surface of this wall was obscured by a layer of mortar and by layer 1230 (a spread of crushed brick which probably represents a demolition layer or make up for the modern yard surface).

- 3.4.29 Wall 1204 was built of randomly coursed handmade red unfrogged bricks lain in a white lime mortar. Many of the bricks used, particularly within the core of the wall, were broken, and some showed signs of being re-used. In its original form, this wall was probably built on stepped brick foundations.
- 3.4.30 Wall 1222 was slightly more substantial, at some 1.15m wide. The uppermost surviving courses appeared to butt the southern face of wall 1204, but time constraints meant that this could not be proven through excavation. There was no opportunity to examine the lower courses or foundations of this wall for the same reasons. This wall continued beyond the southern limit of the excavations. As with wall 1204, a number of the handmade red unfrogged bricks used in the construction of this wall were broken, and all were lain in a white lime mortar.
- 3.4.31 Drain 1208 was lain along the eastern face of wall 1222, and comprised a completely enclosed channel, with a brick floor of headers, walls of bricks lain as stretchers and a capping of headers. This channel ran the length of wall 1222, and through the thickness of wall 1204, terminating in the thickness of a brick built 'buttress'. Perhaps surprisingly, the drain does not extend further to the north, or terminate in a soakaway, although this evidence may have been removed by later truncation.
- 3.4.32 At some time during the life of this structure, it was considered necessary to thicken wall 1204 through the construction of a wall 1206 immediately against its northern face. This may have been done for structural reasons – to strengthen the wall to allow for the addition of another storey to the building for example – or for aesthetic reasons, such as the addition of a more fashionable façade. This new wall was some 0.60m wide, and built of unfrogged red handmade bricks. It is uncertain whether this thickening was confined to the eastern stretch of wall 1204 only. The foundations to the west of wall 1222 was built on foundations of stepped brick, whilst those to the east were not stepped, and included a number of large pieces of architectural sandstone. The latter presumably represent material re-used from an earlier (possibly Medieval) building in the vicinity. The fact that these two facings have different foundations may be significant, and may indicate that these were not added at the same time. There was no opportunity within the time constraints of the project to examine this possibility further.

- 3.4.33 The thickening of wall 1204 with 1206 must have been complete prior to the addition of 1207, a semi-hexagonal brick structure. A similar structure, 1217, a semi-octagonal brick structure was also added to the front of this range. It is unclear whether these were contemporary additions. Indeed, there are sufficient differences in their construction to indicate that they may have been built at different times. Structure 1207 was built of broken and re-used unfrosted red handmade bricks on a solid base of flints lain in a hard white lime mortar matrix (1210), whilst 1217 appeared less well built, and showed no evidence for similarly well made foundations. Structure 1207 is likely to have been a bay window facing onto the formal gardens to the north, whilst 1217 may either have been a bay window or a stair tower, although the shallow nature of these foundations makes the former seem more likely. The differing forms of these two structures on the same façade may suggest that they formed part of a wider symmetrical pattern.
- 3.4.34 The final phase of construction associated with this building was the construction of a circular brick soakaway (1205) against the north face of wall 1206. The construction cut for this soakaway – cut 1229 – damaged both the face of wall 1206 and the western face of flint foundation 1210. Its location suggests that it may have been dug to take water run off from the roof via a down pipe. A brick lined drain, 1225, was also built in a shallow cut (1227) leading away from this soakaway from the north west suggesting that it took waste water away in this direction. This drain was similar in construction to 1208, but had suffered greater truncation. Unfortunately, time constraints meant that it was not possible to investigate the fill of this soakaway (1209) further.
- 3.4.35 No intact floor surfaces were revealed within the building. Mixed layers of silty clay containing flint pebbles, mortar inclusions and numerous fragments of broken brick and tile were recovered from within both of the bay windows (layers 1218 and 1228). Six sherds of 12th to 13th century pottery were recovered from layer 1218, and are probably residual. Similar deposits were encountered to either side of wall 1222 within the building. To the east of this wall, layer 1221 was a dark greyish brown silty clay containing very occasional small sub rounded and sub angular pebbles. It also contained some charcoal, mortar flecks and broken and crushed brick and tile. Layer 1216, to the west of wall 1221, was very similar, apart from a number of areas of concentrated charcoal. All of these layers appear to represent layers which accumulated either during the construction or the demolition of the buildings.
- 3.4.36 Some of the concentrations of charcoal noted within layer 1216 appeared to coincide with a series of crudely made depressions cut into the west face of wall 1222 and the south face of wall 1204. Some nine semi-circular cuts had been made into the west face of 1222 some time after its construction. Typically these measured some 0.35m wide, and were relatively evenly spaced, with the distance between the centre of adjacent cuts was approximately 0.5m. The clue to the purpose of these cuts was provided by

the one cut evident in the south face of wall 1204. Here, the cut formed a rectangular step cut into the back of the wall, some 0.25m wide. Its eastern end formed a semi-circular end similar to those cut into wall 1222. The form of these cuts suggests that they were designed to hold substantial timbers, presumably to act as floor joists for a suspended floor. The concentrations of charcoal in layer 1216 probably coincided with the location of the gaps in these joists, and probably represent material derived from activity within the room above during the use of the building. This would also suggest that layer 1216 probably represents a layer associated with the construction rather than the demolition of the building – a tentative conclusion supported by the presence of what appeared to be a patch of natural drift geology (1211) in the south western corner of the trench. Pottery recovered from layer 1216 dates to the Medieval period (one sherd of 12th to 13th century pottery) and the Post-medieval period (one sherd of Post-medieval redware)

3.4.37 Some deposits likely to be associated with the demolition of the building were identified – notably layer 1230, a layer of compacted crushed brick and mortar covering the buried remains against the western edge of the site.

3.4.38 Two alternative phasing sequences can be suggested for the Tudor structural remains on the basis of the structural remains as currently understood. In the first of these, there are 5 phases of structural work:

- Phase 1. The western half of 1204, wall 1222 and drain 1208 form the north-eastern corner of a building, probably aligned north – south judging from the results of the geophysics survey. In this case, drain 1208 probably ran along the external face of the building. This scenario also explains why wall 1222, ostensibly an internal wall, was so substantial.
- Phase 2 The eastern section of wall 1204. This is very similar in construction to the western half of 1204. It may have been built at the same time or shortly afterwards, although it lacks its size, and may either have been a boundary wall or part of a less substantial structure.
- Phase 3. At a later date, the eastern stretch of wall 1204 was thickened by the construction of wall 1206. It is clear at this stage that the area to the east of wall 1222 lay within a building.
- Phase 4. Bay windows (or a bay window and a stair tower) were added to the north face of the range of buildings. These are of different construction, and may have been added at different times, or may form part of a carefully designed frontage.
- Phase 5. A brick built soakaway was constructed in the junction between wall 1206 and bay window 1207. The construction cut for this damaged the brick face of both walls.
- Joist holes were cut in to the rear face of walls 1204 and 1206 at some point after their construction to take very substantial timbers aligned roughly east west and some 0.5m apart. The exact phasing of this work is unclear.

3.4.39 In the second, there are fewer phases, but an equally complex structural history.

- Phase 1. The full length of wall 1204 (only some 0.7m wide) was built, along with wall 1222 and drain 1208. In this case, wall 1222 appears disproportionately too large, whilst drain 1208 is an internal feature.
- Phase 2. The full length of wall 1204 in Trench 12 is thickened by the construction of wall 1206, which in this scenario runs across the full width of the trench.
- Phase 3. Bay windows are added to the northern face of the range.
- Phase 4. The brick built soakaway was built.
- As above, the cutting of the joist holes for the floor in the western room cannot be phased closely.

3.4.40 Although both scenarios have their advantages, it is the authors' view that the former best explains the archaeological remains uncovered in conjunction with the results of the geophysics survey, but this has not been proven by excavation.

3.4.41 The remains of a Late Medieval or Post-medieval garden soil (1203) were recorded to the north of the Tudor or Post-medieval building. This layer, a light to mid grey brown silty clay containing moderate small sub rounded flint pebbles produced very little in the way of anthropogenic material. Two small sondages were excavated through this soil, which was some 0.25m deep. Both showed that this garden soil sealed Medieval features. In the first of these, a small sondage excavated around the base of the flint foundations of the 'buttress' to the north of wall 1206, the eastern edge of a pit or ditch terminus (1224). Although there was no time to excavate this feature further, hand cleaning of layer 203 above the visible fill - layer 1223 – recovered a number of sherds of Medieval pottery, which probably originated within this feature.

3.4.42 The second sondage, in the north-eastern corner of the trench revealed another substantial Medieval feature – cut 1212. Once again, its extent could not be fully determined within the confines of the sondage. It appeared to take the form of a substantial pit or ditch terminus, some 1.5m wide. An intervention excavated through this established that it was some 0.50 m deep, and contained two fills – layer 1226, a thinnish rapidly formed primary silt, and layer 1213, a thick slowly formed secondary fill. Sherds of pottery recovered from fill 1226 have been dated to the 12th or 13th century.

3.4.43 A number of later Post-medieval and modern features and deposits were excavated within Trench 12. These included six pits dug as part of a Post-medieval or Victorian planting scheme. These oval or roughly circular pits (1215, 1231, 1232, 1233, 1234 and 1235) were cut through the remains of the Tudor building, features and deposits. These probably contained small shrubs or trees, although the fact that many were dug into the tops of the remains of walls or wall foundations probably meant that the plants are unlikely to have

prospered. These were filled with deposits indistinguishable from the material they were cut through – layer 1202, the demolition deposit which covered much of the trench, and which contained sherds of Post-medieval pottery. A modern pipe trench was also excavated within this trench (cut 1219). The only fill of this trench, layer 1220, contained a metal pipe some 5cm in diameter.

Trench 13 (Figure 10)

- 3.4.44 Trench 13 was a small hand dug trench located within the lawned area of the courtyard. This was excavated to examine a large circular anomaly revealed by the ground penetrating radar survey. The trench, which was 1m square, was targeted on the eastern edge of this anomaly. The topsoil (1301) and subsoil (1302) were removed to reveal the edge of a large circular cut (1303). The upper fill of this feature (1304) was partially excavated. This brown silt clay loam contained frequent brick (including frogged bricks) tile and mortar inclusions. There was little scope within such a small trench to excavate the feature fully. The presence of frogged bricks in the upper fill date this to the late 18th century or later. The function of the feature itself is unclear, although it may originally have been dug as a well, in which case it may have been dug in the Tudor or Post-medieval period.

Trench 14 (Figure 12)

- 3.4.45 A machine excavated trench was dug in the farm yard to the west of the manor and to the north of the barn in order to examine the possibility of archaeological deposits and features surviving in this area. It measures some 5.8m by 3m. A simple sequence of deposits was identified within the trench. The gravel of the yard surface (1401) was removed to reveal a compacted linear layer of crushed chalk with flint nodules and smaller quantities of large rounded pebbles and broken unfrogged red bricks (1402). A section was excavated through this layer, revealing that the deposit lay in a shallow scoop cut into the underlying natural (1403) which may represent the remains of a wall footing, or possibly a compacted trackway. In the south western corner of the trench, layer 1404 marked the location of a possible feature. This mixed deposit contained much building rubble. It was decided not to investigate this feature further.

Trench 15

- 3.4.46 Trench 15 lay in the grassed area to the north of the recently restored ‘Old Nursery’ building. This machine-excavated trench, measuring 3m by 1.2m, was targeted on a linear anomaly identified in the geophysics survey. The topsoil (1501) and subsoil (1502) were removed, revealing a modern pipe trench (1504) cut into the natural gravels (1503). A brief investigation of 1505, the fill of 1504, confirmed the presence of a modern pipe. No other archaeological features or deposits were revealed in this trench.

Trench 16

- 3.4.47 Trench 16 was a machine-excavated trench to the west of Trench 15, and was dug in order to evaluate the possibility of archaeological remains and deposits in this area. The trench measured 4m by 1.2m. An undisturbed sequence was revealed, with the topsoil (1601) and subsoil (1602) sealing the undisturbed natural gravels (1603). No archaeological features or deposits were identified.

Trench 17 (Figure 12)

- 3.4.48 Trench 17 lay to the west of Trench 14, and to the north west of the barn. It was excavated by machine and measured 5m by 1.2m. A similar sequence to that observed in Trench 14 was recorded. The grey gravel of the car park surface (1701) overlay a layer of tarmac (1702). This in turn sealed a layer of compacted chalk (layer 1703). This lacked the flint and brick inclusions of layer 1402, and may not represent the same layer. It seems to have acted as a bedding layer for the tarmac, and as lain directly on a buried subsoil (1704), which in turn sealed the natural gravels (1705).

Trench 18 (Figure 11)

- 3.4.49 Trench 18 lay to the south east of Trench 12. It was excavated by machine in order to establish the position of the southern wall of the range identified in Trench 12. The upper layer excavated by machine – layer 1801 – was a very mixed deposit containing much ceramic building material and domestic waste. Finds from this layer include two fragments of faience tile dated to the early 16th century.
- 3.4.50 This layer sealed the only archaeological feature within the trench – a very large pit or ditch terminus, which extended beyond the eastern limits of the trench. This took the form of a roughly circular cut (1802) with steepish sides, which could be some 0.5m in diameter. A small section was excavated into this feature, and some of the upper fill (1803) removed. This fill contained large quantities of broken tile and ceramic building material. Unfortunately, time constraints meant that this feature could not be excavated further. Its exact function is unclear, although it may have acted either as a well or as a soakaway, or may have been a pit associated with the demolition of the buildings in this area.

4 FINDS

4.1 Introduction.

- 4.1.1 Finds were recovered from 11 of the 18 trenches excavated, (Trenches 1, 2, 4, 5, 6, 7, 8, 9, 11, 12, 13 and 18) with all material coming from stratified contexts within those trenches, from phases relating to the life and use of the manor house during the 16th and 17th centuries and the subsequent demolition and levelling of a number of buildings in the periods that followed.

- 4.1.2 The assemblage comprises mainly bulk finds, with a smaller proportion of individually recorded Objects ('small finds'), mainly metalwork, with some animal bone, glass, clay pipe and ceramic building material. All finds have been cleaned (except for the metalwork) and have been quantified by material type within each context. There is also a register of individual Objects. Quantified data form the primary finds archive for the site, and this data is summarised by trench in **Table 2**.
- 4.1.3 Subsequent to quantification, all finds have been visually scanned in order to gain an overall idea of the range of types present, their condition and their potential date range. Pottery, glass and ceramic building material have been subjected to a more formal scanning, including quantification by ware group/type (details below). Spot dates have been recorded for selected material types as appropriate. All data are held on the project database (Access).
- 4.1.4 This section presents an overview of the finds assemblage, on which is based an assessment of the potential of the material to contribute to an understanding of the Site in its local and regional context.

4.2 Pottery

- 4.2.1 The assemblage of pottery includes material of early Bronze Age, Medieval, Post-medieval and Modern date.
- 4.2.2 A single residual sherd of grog-tempered ware identified from 201 (topsoil in Trench 2), was most probably early Bronze Age in date (2400-1500BC).
- 4.2.3 The remainder of the assemblage can be dated to three main periods, Medieval (12th and 13th centuries), Post-medieval (AD1500-1799) and Modern (1800-present).
- 4.2.4 The Medieval fabric types identified include calcareous wares, sandy wares and flint-tempered wares. Calcareous and sandy wares were recovered from 217 (fill of north-south ditch 216). Demolition layer 402 contained sherds of flint-tempered ware, as did redeposited gravel layer 702, and 809, the backfill of the construction cut for east-west aligned wall 804. Garden soil layer 1203 produced calcareous, sandy and flint-tempered wares with demolition layers 1216 and 1218 also containing sandy and calcareous wares. Layer 1213, the primary fill of pit/ditch terminus 1212 also contained sherds of sandy and flint tempered pottery dating to the 12th and 13th centuries.
- 4.2.5 Of the Post-medieval fabric types recovered, the earliest material comprised two sherds of Border Ware from the Surrey/Hampshire border industry. A body sherd from 102 (subsoil in Trench 1) and the handle of a chafing dish

from 115 (modern pipe cut). Subsoil 201 also contained two sherds of salt-glazed stoneware, one dated mid to late 17th century and one 18th century. Two further sherds of stoneware, both Westerwald types, were recovered from redeposited gravel layer 702 and 902, the subsoil of Trench 9. These are dated from the mid 17th to 18th century.

4.2.6 The majority of the Post-medieval pottery assemblage comprised coarse redwares, including 27 sherds (15 with lead glaze) from 102, eight sherds from rubble layer 105 and a single sherd from 115, all in Trench 1. The topsoil of Trench 2 contained a single sherd of coarse redware, as did the topsoil of Trench 8. Demolition layer 1216 and modern soak-away fill 1304 also contained a single sherd each, two sherds were recovered from 902 and three from 1202 including an example of Metropolitan slip ware (17th century). A single sherd of 18th century black Basalt ware was also recovered from the subsoil of Trench 1.

4.2.7 The pottery dated to the modern period consisted of refined white wares, both plain and transfer printed, with examples from deposits 105, 115, 201, 701, 902 1202 and 1304. Layer 102 contained 53 sherds of refined whitewares including a sherd of late 18th century pearlware and a sherd of 19th century Mocha ware.

4.3 Ceramic Building Material

4.3.1 Ceramic building material (CBM) was recovered from Trenches 1, 2, 6, 7, 8, 9, 12, 13 and 18, with the assemblage comprising of floor tiles, roof tile and bricks.

4.3.2 The floor tiles are all incomplete, with 102, 1201 and 1216 producing glazed examples of varying colours. Trench 18 produced the most diagnostically datable example of CBM in the form of two fragments of a Delft medallion tile (e.g. Britton 1986, 172-3, nos. 186-91) dated to the early 17th century (from demolition layer 1801).

4.3.3 Roof tiles were recovered from stratified contexts within Trenches 1, 2, 6, 7, 8, 11 and 12 and were all fragmentary and largely undiagnostic with the exception of peg tile from 102 and 1304, both which had seen modern re-use.

4.3.4 Eighteen contexts produced examples of brick on the Site, with the majority coming from layers, fills or demolition deposits. A number of brick samples were taken from *in situ* structures and foundations, these included examples from wall 106 in Trench 1 and 204 in Trench 2, and walls 1204, 1206 and 1222, bay window wall 1217 and culverts 1208 and 1225 in Trench 12. Deposit 1216 also contained an example of moulded brick from a chimney breast, other examples of this can be seen in the chimneys of the Manor today. All bricks recovered were tentatively dated to the 16th –17th century.

4.3.5 Mixed subsoil/demolition layer 902 produced a shaped and frogged brick dating to the late 18th century.

4.4 Clay Pipe

4.4.1 The clay tobacco pipes comprise stem fragments, one (from Trench 12) with a spur stamped W/P (maker unknown).

4.5 Glass

4.5.1 Glass fragments were recovered from nine contexts in six trenches across the Site. Layers 102, 1201, 1202, 1203, 1216 and 1218 contained examples of 16th century window quarries; the fragments are in a very degraded condition, almost devitrified. 105 produced a fragment of vessel glass dated between *c.*1650 and *c.*1750 and 1202 produced a fragment of a small square based phial (late 17th to early 18th century). The remaining glass fragments recovered represent modern vessel and window glass.

4.6 Stone

4.6.1 The stone comprises 12 pieces of slate recovered from contexts 1202, 1216 and 1218 in Trench 12. These deposits represent demolition layers and the slate fragments represent the remains of roofing material.

4.7 Worked Flint

4.7.1 A single flint flake with edge damage was recovered from the garden soil deposit 1203 in Trench 12. This flake is not particularly chronologically distinctive, but morphology and technology (broad, squat flakes struck using hard hammer technique) would be consistent with a Bronze Age date.

4.8 Metalwork

4.8.1 The metalwork assemblage includes objects of copper alloy (6), iron (36) and lead (5).

Copper Alloy

4.8.2 The majority of the copper alloy objects recovered were from items of clothing, both functional and decorative. Three lace tags or aiglets were found in contexts 102, 105 and 702, two of which are typical of practical, functional lace tags, whereas the third from 702 is unusual in its size, being some 70mm long, and is more likely to be for more decorative display. Each lace tag was formed from a sheet of copper alloy folded to form a tapered tube, and pinched to hold the lace in place.

- 4.8.3 A small copper alloy button with an iron shank was recovered from the topsoil of Trench 2.
- 4.8.4 A small thin sheet of copper alloy was recovered from deposit 1218, the function of which is uncertain, and a Post-medieval penny (very worn) came from deposit 803.

Iron

- 4.8.5 The majority of the iron objects are nails and were recovered from Trenches 1, 8, 9 and 12 from within demolition or levelling deposits. Though well corroded, they can be seen to have square-sectioned shafts and are assumed to be structural nails.
- 4.8.6 A number of other iron objects are of interest including a looped spike recovered from Trench 9 and the heel iron from a shoe or boot from demolition layer 1202 in Trench 12. A potential blade was recovered from rubble layer 105, but its corroded nature makes identification difficult.
- 4.8.7 Other objects, at this stage unidentified, were recovered from deposits 606 and 902.

Lead

- 4.8.8 The lead objects consisted of window came fragments from deposits 1202 and 1216 and pieces of unknown function, potentially off-cuts from the manufacture of the came itself (from 201 and 902). It is difficult to determine whether the came is cast or machine milled (see Knight 1985, fig. 48, no. 2), but is more likely to be the latter given the date of the window glass from the same deposits.

4.9 Animal Bone

- 4.9.1 Of the 69 bones recovered, most were in fair condition with a small number in Trench 7 in poor condition due to a flaky, eroded bone surface. Gnawing has affected the assemblage from most trenches and gnawing marks were noted on 7% of fragments. However 54% could be identified, dominated by cattle and sheep/goat in equal numbers, with a smaller proportion of pigs (of a large size) and birds, including domestic fowl and a small bird, similar morphologically to the lapwing. Lapwings breed in areas with a mosaic of habitats including unimproved pastureland or rough grazing rather than arable, with wet, grassy areas nearby (RSPB). In winter the birds flock to coastal, estuarine or flooded areas, as well as short grassland or ploughed fields.

Table 1: Animal bone species list and percentages (NISP)

	Cattle	Sheep/Goat	Pig	Bird	Unidentified	Total
NISP	13	13	3	3	37	69
% of identified fragments	41	41	9	9		

4.9.2 30% of bones could be aged or sexed and 12% could be measured to indicate animal size. Some periosteal new bone growth on a mature cattle radius may indicate infection. 17% of bones were observed to have butchery marks, of which the majority are knife cuts for disarticulation or chops through the bone, although a cattle rib in Trench 9 had been sawn through, a predominantly modern technique used to portion the ribcage. Saws appear to have been used predominantly in bone working prior to the modern period, perhaps being too valuable for use in butchery. A piece of large mammal bone found in 1203 had been worked, it is apparently a broken piece of knife handle, rectangular in section and polished internally with external decoration of diagonal knife cuts.

4.9.3 The distal parts of a femur and tibia of a young sheep/goat were found in Trench 9, possibly both from one individual. Two thirds of the assemblage was from Trench 12, and the larger number of bones is reflected in a larger range of species (5) than that found in the other trenches; the ?lapwing and worked bone were both from this Trench.

4.10 Marine Shell

4.10.1 The marine shell comprises small quantities of oyster (both left and valves, i.e. both preparation and consumption waste) and cockle, all from Trench 12.

Table 2: All finds by Trench (number / weight in grammes)

CBM = Ceramic Building Material													
Material type	Tr. 1	Tr. 2	Tr. 4	Tr. 5	Tr. 6	Tr. 7	Tr. 8	Tr. 9	Tr. 11	Tr. 12	Tr. 13	Tr. 18	Total
Pottery	99/1203	9/101	1/4	-	-	4/34	2/13	3/66	-	45/387	3/58	-	166/1866
<i>Prehistoric</i>	-	1/1	-	-	-	-	-	-	-	-	-	-	1/1
<i>Medieval</i>	-	5/77	1/4	-	-	1/21	1/6	-	-	40/309	-	-	48/417
<i>Post-medieval</i>	99/1203	3/23	-	-	-	3/13	1/7	3/66	-	5/78	3/58	-	117/1448
CBM	26/1923	13/5824	-	-	10/3844	5/123	36/1889	7/3215	21/986	54/26,946	6/4833	2/106	180/49,689
<i>Roof tile</i>	19/1657	9/783	-	-	7/616	5/123	35/1859	6/665	3/138	10/759	3/1333	-	97/7933
<i>Floor tile</i>	1/150	-	-	-	-	-	-	-	-	7/1818	-	2/106	10/2074
<i>Brick</i>	6/8116	4/5041	-	-	3/3228	-	1/30	1/2560	18/848	37/24,369	3/3500	-	73/47,692
Glass	10/68	2/61	-	-	-	1/7	2/2	3/32	-	73/261	-	-	91/431
Clay Pipe	7/27	1/1	-	-	-	-	1/3	-	1/1	4/10	1/1	-	15/43
Metalwork	14	2	-	-	1	1	4	3	-	12	-	-	37
<i>Coin</i>	-	-	-	-	-	-	-	-	-	1	-	-	1
<i>Cu alloy</i>	2	1	-	-	-	1	1	-	-	-	-	-	5
<i>Iron</i>	12	-	-	-	1	-	3	3	-	9	-	-	28
<i>Lead</i>	-	1	-	-	-	-	-	-	-	2	-	-	3
Animal Bone	11/73	3/92	-	1/21	-	4/27	-	7/32	-	45/547	-	-	71/792
Other Finds	-	-	-	-	-	1 burnt flint	-	-	-	1 worked flint; 12 slate; 15 oyster shell	-	-	-

5 ENVIRONMENTAL EVIDENCE

- 5.1.1 No environmental samples were recovered during the course of the project.

6 DISCUSSION

- 6.1.1 The archaeological evaluation at Chenies Manor has been very successful in achieving the aims and objectives of the project. The evaluation trenching, geophysical survey and dendrochronological work have all contributed significantly to enhancing our understanding of the site. The results of this work provide us with evidence for the probable location of the Medieval manor of Isenhampstead, as well as shedding further light on the development of the Manor House complex in the Late Medieval and Tudor periods, and the subsequent neglect and demolition of much of this complex with the decision of the Russell family to use Woburn Abbey as their principal residence from 1608.
- 6.1.2 The evaluation trenching revealed evidence for a phase of 12th - 13th century occupation on the Site. This took the form of a number of features cut in to the natural drift geology. Two parallel ditches were excavated in Trench 2, whilst removal or areas of the Tudor and Post-medieval Garden Soil in Trench 12 revealed two substantial features that may represent either pits or ditch termini. Pottery recovered from the fills of most of these suggests that they were functional during the 12th and 13th centuries. In addition to these features, material was also recovered either unstratified or in later deposits in Trenches 4, 7, 8 and 12, further indicating the presence of Medieval activity on the Site during the 12th and 13th centuries. Whilst there is nothing in this small assemblage to suggest that these features represent the remains of a high status manorial complex, the favourable location of the site to the west of the parish church (which also contains 12th century elements) on a slight rise, and the fact that the Late Medieval and Tudor Manor occupies the Site strongly suggest that this was the location of Isenhampstead Manor, owned by the Cheyne family, and for a brief time by Edward I.
- 6.1.3 There is currently some debate regarding the date of the surviving remains of the Medieval or Late Medieval undercroft, with estimates ranging from the 13th to the 15th or 16th century. Originally this undercroft was entered from both the west and the east (English Heritage Scheduled Monument entry). Its situation on the Site does point to the probable location of the main range of the Medieval or late Medieval manor house, which is likely to have included a hall, domestic solar range and kitchens. Some structures within this complex are likely to have been fairly substantial, notably the hall and solar, and may have been built either in stone or of timber framed construction. Elements of this late Medieval complex would almost certainly have been incorporated within the first Tudor rebuild, and the survival and subsequent modification of the undercroft indicates that it continued in use throughout

this period. It is likely to have lain at one end of the hall range, possibly beneath the solar. The alignment of the undercroft suggests that the main hall is likely to have been aligned north-south, on a similar alignment to the later Tudor range which still survives as the west range of the manor, and the solar probably lay at one end of this range.

6.1.4 Although the Medieval manor is likely to have seen alteration and improvement work during the tenure of the Cheyne family, it is unlikely to have been a complex sufficiently impressive to either merit or cope with a visit from the Royal court. This changed with the marriage of John Russell and Ann Sapcote in 1526. As an important figure in Henry VIII's court, John Russell needed a home which not only befitted his status, but was also capable of housing the king and his retinue if necessary. His decision to use Chenies as his main residence may have been influenced by its proximity to the London and the royal palaces. He undertook extensive works to the complex he had acquired through marriage. Indeed, these were so substantial that by the time of Leland's visit on one of his itineraries, probably in 1544, he remarked little of the original house had survived the alterations and that much of the house was newly built in brick and timber. He also refers to new lodgings having recently been built in the garden.

6.1.5 The dendrochronological work has established that the present west range is likely to date to this phase of construction. Three of the five samples taken from the roof over the southern block of the west range indicate that the timbers were felled in a period between spring of 1537 and summer of 1538. Three of the four samples taken from the northern block of this range provided felling dates of 1515-47, 1517-49, and 1518-50. Although less closely dated than those in the southern block, the similarity in their respective roof structures sufficient to indicate that they are broadly contemporary. This indicates that the west range had probably been recently built at the time of Leland's visit, and that the work post-dated the first visit of Henry VIII to the manor in 1534. The date suggested for this range might indicate that it is the 'fair lodgings new erected in the garden' mentioned by Leland. It seems likely however, that the buildings referred to by Leland were those used to house William Cecil, Arch Chancellor to Elizabeth I on her visit to the manor in 1570 in order to afford him peace and quiet. The proximity of the current west range to the late Medieval undercroft suggests that it lay close to the heart of the complex, and would have been ill suited to providing peace and quiet. The location of the lodgings in the garden is still uncertain. The dates indicated by the dendrochronology significantly alter the dating suggested for these ranges in previous work, placing them later on in the Tudor period than originally thought (see 1.3.17 above).

6.1.6 It is not clear at what stage the now demolished north wing was built. The wall identified in Trench 2 almost certainly marks the northernmost extent of this range. The 1839 Tithe Map for the parish shows the shadow of this range preserved in the courtyard wall (see Figure 13). This wall appeared clearly on the geophysics plot of the area. The southernmost extent of this range is

unclear. The geophysics survey suggests two possible locations. Both of these were investigated by evaluation trenches. The anomaly investigated in Trench 7 would seem the most logical for the southern wall of the range – this would indicate that the now missing north range was similar in width to the surviving south range. No wall was identified in the very small trench, and the gravelling identified was consistent with the presence of a yard surface. The second strong anomaly within the courtyard, investigated in Trench 8, did indeed turn out to be a wall. If this represents the south wall of the north range, the width of this range would be some 11.6m, very similar to the width of the contemporary parish church. Neither of these presents a convincing solution. The Tudor wall excavated in Trench 1 lies on the line of the eastern courtyard wall shown in the Tithe Map, and probably marks the line of the original perimeter wall of the complex, whilst the heavy flint cobbling identified beneath the modern churchyard wall in Trench 10 lies on the line of the access to the manor depicted on the 1839 Tithe Map.

- 6.1.7 The earliest elements of the structural remains identified during the evaluation in Trench 12 are likely to have been built as part of John Russell's expansion of the manor house. Although these cannot be closely dated on the basis of the archaeological work undertaken, their proximity to the remains of the Medieval undercroft and hence to the heart of the Medieval manor suggest that these represent the first expansion of the manor house. From the limited remains excavated, it is unclear the function performed by these new buildings, although presumably some of the new structures within the complex were designed to improve the domestic accommodation offered.
- 6.1.8 The continued development of the structures in Trench 12 no doubt represent the desire to maintain a suitable complex worthy of hosting the Royal court. The thickening of wall 1204 with wall 1206 may reflect this desire – whether the aim was to provide a more fashionable façade to the building or to allow greater stability for adding another story to the building. The inclusion of carved blocks of soft limestone (clunch), very similar to that used in the construction of the surviving Late Medieval undercroft, within the foundations for wall 106 may indicate that this was undertaken as part of a larger phase of work, perhaps including some demolition of the extant elements of the Medieval manor house. We cannot be certain how extensive the works undertaken by John Russell at Chenies were.
- 6.1.9 Some of the later alterations undertaken to the buildings excavated in Trench 12 – specifically the addition of two possible bay windows – were designed to improve the standard of the accommodation. These alterations point to this block being designed to offer extensive views over the formal gardens to the north of the house. It is possible that these two rooms formed part of a larger block aligned to exploit the same views. Geophysics survey to the west and south west of Trench 12 identified a number of anomalies which may correspond to walls of a wing aligned roughly west – east and which incorporated the structures in Trench 12.

- 6.1.10 An archaeological walkover survey of the area was undertaken by Stewart Ainsworth of English Heritage, along with a detailed study of cartographic and written sources. This indicated that the Tudor complex was probably originally approached from the west, with the building now known as the Old Nursery potentially originally built as a gatehouse, possibly one of a pair. It is unclear when the main approach to the complex shifted to the east although this may have happened with the construction of the present south range. The extensive terrace to the north of the manor complex is likely to have been taken up with formal gardens, with the smaller Privy garden lying to the south. The manor probably had two hunting parks, which probably lay to the west and south-west of the house.
- 6.1.11 John Russell, who undertook the extensive rebuilding of Chenies Manor, died in 1555. Francis Russell, his successor, despite falling foul of the crown shortly after the death of his father, regained the favour of the court with the accession of Elizabeth to the throne. She visited Chenies in 1570. By the time Francis inherited the manor on his father's death in 1555, the manor was at its peak. The new south range would have been completed a few years before his death, and the whole complex would have been impressive to behold – three ranges of buildings grouped around a central courtyard with a substantial accommodation range facing the gardens to the north, an inner and an outer courtyard, extensive gardens containing a separate accommodation block and state apartments fit for Royalty. Yet within a little over 50 years, the family had left Chenies for ever, and the gradual decline of the complex began.
- 6.1.12 On the death of Francis in 1585, an inventory of the manor at Chenies listed nine bedrooms of consequence, three kitchens, a buttery, a ewery, a bolting house and woodsheds, as well as an armoury, outbuildings containing room for storage and for servants' accommodation. His wife, the dowager countess, died in 1601, and the family left in 1608, moving to their house at Woburn and leaving the complex to the care of a steward. Some of the archaeological features identified in these excavations undoubtedly represent features or structures of this date. The surfaces and later walls identified in Trench 1 probably date to the 18th or 19th centuries.
- 6.1.13 The extraordinary expansion of the manor at Chenies followed by its gradual decline mirrors not only the fate of a number of similar such complexes built at great expense to house the Royal court in its perambulations throughout the land and then too expensive to maintain, but also the fortunes of the family. The rise to magnificence of Chenies under John Russell led to a gradual decline under his less stellar descendants. The massive complexes needed to house a Royal court were prohibitively expensive to maintain, and were often erected rapidly, with speed rather than build quality the driving force. Once the family chose Woburn as their family home, the fate of much of the complex at Chenies was sealed. The family's steward would no doubt have maintained his own lodgings, the present west range was rented out, whilst the south range was left periodically empty before being incorporated

within the Manor Farm complex. By the mid 18th century, some elements of the complex, and in particular the north range, were in a disastrous state of repair, and were probably dismantled shortly afterwards.

7 RECOMMENDATIONS FOR FURTHER WORK

7.1.1 This assessment demonstrates that the work undertaken by Time Team at Chenies Manor has significantly enhanced and altered our understanding of the origins, layout, nature and extent of the Tudor complex at Chenies Manor. It has added to our understanding of the Medieval origins of the complex and altered our understanding of the development and decline of the Tudor complex. In particular, the combination of geophysical survey, trial trenching and dendrochronology have all contributed new evidence for analysis.

7.1.2 In view of the significance of these results, it is recommended that a programme of further work be undertaken with a view to the publication of a short article outlining the results of this investigation in an appropriate journal (Post Medieval Archaeology). This short note should provide the background to the project, a summary of the main findings, and a discussion of the results. Plans, sections and photographs may be used to provide illustrative accompaniment to the text as appropriate. The site data contained within this assessment should be used to form the basis of the structural report.

7.1.3 A copy of this assessment report will be lodged with the Buckinghamshire Sites and Monuments Record, along with a copy of the geophysical survey report and the dendrochronology report.

8 THE ARCHIVE

8.1.1 The archive, which includes all artefacts, written, drawn and photographic records relating directly to the investigation is undertaken, is currently held at the offices of Wessex archaeology under the site code CHE 04 and Wessex archaeology project No 55754. The paper archive is contained in one lever arch file. In due course, Time Team will transfer ownership of the archive to the appropriate registered museum.

- Baillie, M. G. L, and Pilcher, J R, 1973 A simple cross-dating program for tree-ring research, *Tree-Ring Bulletin*, **33**, 7-14
- Baillie, M. G. L, 1982 *Tree-Ring Dating and Archaeology*, London
- Britton, F., 1986, *London Delftware*
- Chandler, J. (ed.), 1993 *John Leland's Itinerary. Travels in Tudor England*. Alan Sutton, Stroud.
- Ekwall, E, 1960, *The Concise Oxford English Dictionary of English Place Names* (4th edition) Clarendon Press, Oxford
- GSB, 2004. *Chenies Manor, Buckinghamshire: Geophysical Survey*. GSB Report 2004 / 24. GSB Prospection Limited unpub. report.
- HAT, 2000, The Old Nursery, Chenies Manor, near Amersham, Buckinghamshire. Historic Building Recording and Archaeological Monitoring and Observation. Hertfordshire Archaeological Trust Report No. 754. Unpublished client report
- Knight, B., 1985, 'Cames' in Hare, J.N., *Battle Abbey: The Eastern Range and the Excavations of 1978-80*, HBMCE Archaeol. Rep. 2, 154-6
- Miles, D H, 1997 The interpretation, presentation, and use of tree-ring dates, *Vernacular Architect*, **28**, 40-56
- Pevsner, N. and Williamson, E. 1994. *The buildings of England: Buckinghamshire* (2nd edition) Penguin, Harmondsworth.
- Ray, G. E. 1983, *The book of Chorleywood and Chenies*. Barracuda Books, Buckingham
- RCHME, 1912. An inventory of the historical monuments in Buckinghamshire. Vol 1. South. Royal Commission on the Historical Monuments of England. HMSO, London.
- VCH, 1925. *The Victoria County History of the County of Buckingham* (ed. W. Page)
- Videotext Communications, 2004, Proposed archaeological evaluation Chenies Manor, Buckinghamshire (NGR TQ 0150 9834): Project Design

Worthington, M and Miles, D, 2004. *Dendrochronology of timbers from
Chenies Manor, Chenies, Buckinghamshire.* Oxford
Dendrochronology Laboratory unpub report

APPENDIX 1. TRENCH DESCRIPTIONS.

Trench 1		Length: 4.70m	Width: 1.4m (2.20m max)	Max depth: 0.75m	Ground level: 122.89m OD
Context	Interpretation	Description			
101	Layer	Topsoil. A greyish brown sandy loam			
102	Layer	Subsoil. A dark brown sandy clay loam			
103	Layer	Dumped material. Yellowish brown clay loam			
104	Layer	Mortar and tile surface. Crude surface comprising a mortar spread lain on a bedding of broken tile. Only present in extreme south-western corner of trench.			
105	Layer	Layer of demolition rubble across the trench. A mid brown silty clay containing a high proportion of building rubble, including brick, mortar and tile.			
106	Wall	Short surviving stretch of brick wall aligned north-south. Unfrogged bricks in a yellow mortar matrix lain on a foundation of flints lain in a yellow mortar matrix.			
107	Wall foundation	Foundation wall aligned east-west comprising knapped nodules of flint bedded in a hard yellow mortar. Similar to foundations for 106. No surviving brickwork. Built in construction trench 111.			
108	Wall foundation	Fragmentary remains of wall foundation aligned north south. Comprises uncoursed broken hand-made 'Tudor' bricks in a white lime mortar matrix. Fill of cut 114.			
109	Layer	Gravel yard surface to the west of wall 108. Truncated by 106 and 111 (the foundation cut for 107)			
110	Layer	Backfill of trench 111, dug for wall 107. This backfilling took place after the construction of the foundation, and comprises a yellowish brown silt clay containing a high proportion of mortar flecks.			
111	Cut for wall foundations	The cut of a trench for wall foundation 107. Aligned west east, with very steep regular sides and a flattish base.			
112	Layer	Garden soil. Thickish layer of soil to the east of walls 106 and 108. A brown silty clay loam containing occasional small rounded and sub-rounded pebbles.			
113	Natural	Natural drift geology comprising a yellowish brown silty clay containing moderate amounts of small and medium rounded and sub-rounded pebbles.			
114	Cut for wall foundations	The cut of a trench for wall foundation 108. Aligned north south, with very steep regular sides and a flattish base.			
115	Layer	Fill of modern pipe trench 117. A dark brown silty loam with occasional small and medium rounded and sub-rounded pebbles.			
116	Cable	Modern electricity cable in trench 117.			
117	Modern trench	East-west trench dug to contain a modern electricity cable. Cut through southern edge of wall foundation 107.			
118	Layer	Fill of modern trench 119. A dark brown loose silt loam containing a plastic water pipe.			
119	Modern trench	North-south trench dug to contain a modern plastic water pipe.			

Trench 2		Length: 4.50m	Width: 3.10m	Max depth: 0.82m	Ground level: 123.28m OD
Context	Interpretation	Description			
201	Layer	Topsoil. A mid to dark greyish brown silty clay			
202	Layer	Layer of demolition material on the south side of wall 204. A mid grey yellow brown silt clay containing fragments of brick, tile, mortar and flint.			
203	Layer	Thinnish layer of demolition material on the north side of wall 204. A mid grey yellow brown silt clay containing fragments of brick, tile, mortar and flint.			
204	Wall	East-west wall. Three courses of brick, some of it broken and possibly re-used. These are hand-made 'Tudor' bricks. Lain on top of a deep flint and mortar foundations (205). Lain in a yellow sandy lime mortar.			

205	Wall foundation	Foundation wall aligned east-west comprising knapped nodules of flint bedded in a hard yellow mortar. Upper surface levelled with a layer of re-used roof tiles. Built in construction trench 206.
206	Cut for wall foundations	The cut of a trench for wall foundation 205 and wall 204. Aligned west east, with very steep regular sides and a flattish base.
207	Layer	Thin layer of material used to backfill wall foundation trench 206, after the construction of wall foundation 205 and wall 204
208	Layer	Garden soil. Layer of soil to the north of wall 204. A mid brown silty clay containing very rare small sub-rounded pebbles.
209	Natural	Natural drift geology comprising a yellow clay containing moderate amounts of small and medium rounded and sub-rounded pebbles.
210	Post hole	Cut for a post hole. Ovoid, with irregular, moderately steep sides with a concave base.
211	Layer	The only fill of post-hole 210. A light grey silty clay containing very occasional small sub-rounded and sub-angular flint pebbles.
212	Ditch	North-south aligned ditch against the eastern edge of the trench. Sealed by garden soil. 'V' shaped profile, with moderately sloping straight sides and a concave base.
213	Layer	Only fill of ditch 212. A light yellowish brown silty clay containing very occasional medium sized sub angular and angular flints.
214	Post hole	Cut of modern post-select sub-square cut with steep straight sides and a flat base
215	Layer	Only fill of post-hole 214. A mid grey clay containing the rotted remnants of a wooden post some 10cm in diameter.
216	Layer	The only fill of ditch 217. Pottery recovered from this layer dates to the 12 th – 13 th centuries. A light greyish brown silty clay containing frequent small rounded pebbles.
217	Ditch	The cut of a Medieval ditch aligned north-south, with moderately steep, straight sides and a concave base

Trench 3		Length: 4.72m	Width: 1.40m	Max depth: 0.97m	Ground level: 119.07m OD
Context	Interpretation	Description			
301	Layer	Topsoil. A Garden soil. Dark brown silt loam.			
302	Layer	Made orange brown gravel. The fill of 305. Lies adjacent to 307.			
303	Layer	A layer of dark orange brown silt loam. Lens sealing layer 304.			
304	Layer	A layer of demolition or waste material at the base of trench. Contains frequent burnt maternal, fragments of brick and others ceramic building material, and is thought likely to be Post-medieval in date.			
305	Cut for wall foundation	Cut for retaining wall 307. Very steep sided cut. Base not seen.			
306	Layer	Thin lens of mortar rich material sealing layer's 309 and 308.			
307	Wall	Retaining wall comprising brick facing to a mortared flint core. This was built a third of the way down the slope in order to act as a revetment for the gardens to the south. None of the bricks used in its construction are particularly diagnostic, and the wall must be viewed as Post-medieval in date.			
308	Layer	Mid orange brown loam containing frequent chalk flecks. Butts layer 309.			
309	Drain	Single number allocated to Post medieval or modern gravel filled drain running parallel to the face of wall 303. Very steep sided cut over 0.6 metres deep filled with a compacted layer of yellowish brown gravel. This cut was not bottomed and may represent the line of the service trench, or may be a in drain in its own right.			
310	Layer	An orange brown lens of silt loam containing frequent mortar flecks. Overlying layer 307.			
311	Layer	Dark orange brown silt loam containing fragments of brick, ceramic building material and much mortar. A dump of burnt material at the north end of the trench.			

312	Pit/posthole	Ovoid cut of posthole or small pit to the south of wall drain 309. Containing a single fill - layer 312. Cuts layer's 306 and 308. Moderately sloping sides and concave base.
313	Layer	Dark orange brown silk clay. Only fill of layer posthole 312. Contains small amounts of mortar flecking, but otherwise no dating material.
314	Natural	Natural drift geology comprising a mid orange gravel.
315	Layer	Subsoil. A mid orange brown silt loam, formed as a colluvial subsoil.

Trench 4	Length: 3.35m	Width: 1.35m	Max depth: 0.60m	Ground level: 123.30m OD
Context	Interpretation	Description		
401	Layer	Topsoil. A dark brown silty loam with very occasional small rounded pebbles. In the southern half of the trench, this topsoil is replaced by the compacted gravel of a modern path		
402	Layer	Layer of demolition material. A mid brown sandy clay containing brick, tile and mortar.		
403	Natural	Natural drift geology comprising a well sorted mottled yellow sand containing a very high proportion of small and medium rounded and sub rounded gravels.		

Trench 5	Length: 2.2m	Width: 1.2m	Max depth: 0.80m	Ground level: 122.98m OD
Context	Interpretation	Description		
501	Layer	Number allocated to gravel path and make up layer. The path was laid on a layer of mixed hardcore some 0.20m deep containing much crashed brick, mortar, tile and concrete.		
502	Layer	Single number allocated to modern utility trench and its back fill. This contains a cast iron service pipe and had truncated to most of the deposits within the trench. It had steep sides and a flat base. The fill this cut, a major slightly clay silt contained mixed pebbles, frequent flint rubble and occasional brick fragments and broken concrete, tile and other building debris.		
503	Natural	Light yellow soft friable sand.		

Trench 6	Length: 0.7m	Width: 0.7m	Max depth: 0.5m	Ground level: 123.22m OD
Context	Interpretation	Description		
601	Layer	Topsoil Dark greyish brown silty clay containing very occasional small rounded and sub-rounded pebbles, along with occasional flecks of charcoal and fragments of ceramic building material and tile. Soil of modern flower bed.		
602	Layer	Subsoil. A dark brown silty clay containing occasional small and medium sub rounded to sub angular flints as well as some charcoal, tile and ceramic building material.		
603	Layer	Subsoil (possibly natural drift geology). Yellowish brown silty clay containing a high proportion of small – medium rounded and sub-rounded gravels. Some charcoal flecking.		
604	Cut for wall foundations	Linear cut, aligned west-east containing a 'Tudor' or early Post-medieval wall 606. Cuts subsoil 603, and also contains layer 605. Very steep straight sides and a flattish base.		
605	Layer	A greyish brown silty clay containing very occasional mortar flecks and fairly frequent rounded and sub-rounded pebbles. Also smaller quantities of struck flint and ceramic building material. The struck flint appears to represent debris from dressing flint in preparation for use as a building material. This layer represents a deliberate dump of material in construction cut 604 after wall 606 had been built.		
606	Wall	Brick built wall, aligned west-east. Built of brick on flint foundations, which are levelled off with a line of re-used roof tiles. The brick coursing is random, with some broken bricks used (possibly re-used). The red bricks are laid in a white lime mortar. Wall is cut at its eastern end by wall 609, a Victorian wall. May be 'Tudor' or early Post-medieval in date.		

607	Cut for wall foundation	Linear cut, aligned north-south. Dug for a Victorian garden wall (wall 609). Cuts through wall 606. Very steep sides and a flat base, and contains wall 609 and layer 608.
608	Layer	A dark greyish brown silty clay containing very occasional small rounded and sub rounded pebbles. The fill of 607, after the construction of wall 609.
609	Layer	Victorian brick wall. Aligned north-south. Built of red brick, laid in a yellow mortar, in an English Garden bond. The wall foundations, also in brick, step out slightly from the face of the wall, and include a frogged brick. The wall was probably built in the Victorian period, as a garden wall.

Trench 7	Length: 1	Width: 1m	Max depth: 0.76m	Ground level: 122.89m OD
Context	Interpretation	Description		
701	Layer	Topsoil. Dark greyish brown slightly sandy silty clay. Largely stone free, but containing occasional small flecks of broken brick and tile. A well sorted deposit, more leached towards its base.		
702	Layer	A grey brown sandy silt containing large quantities of rounded and sub rounded small and medium flint gravels. A poorly sorted deposit, this probably represents a gravelled surface such as a yard.		
703	Natural	Yellowish brown gravel layer. Natural drift geology.		
704	Layer	Small sub-circular posthole sealed beneath layer 704. Moderately sloping slightly concave sides with a rounded concave base. Contains a single fill – layer 705		
705	Layer	Grey brown sandy silt containing moderately frequent small and medium flint pebbles and occasional fragments of tile. The only fill of 704. Sealed by later 702.		

Trench 8	Length: 2m	Width: 1m	Max depth: 0.66m	Ground level: 123.22m OD
Context	Interpretation	Description		
801	Layer	Topsoil. Dark grey brown silt clay with rare sub rounded flints		
802	Layer	Subsoil. Mid grey brown silt clay with occasional small sub rounded flints		
803	Layer	Light to mid yellowish brown silt clay containing occasional small sub rounded flints. This is a thin band of demolition material, containing high proportions of broken ceramic building material. This may be associated with the robbing of the brickwork from foundation 804		
804	Wall foundation	A wall foundation, aligned east-west. This comprises a compact layer of broken bricks in light yellow sandy mortar. This extends to the south as a thinner spread, which may represent the make up level for an associated floor.		
805	Layer	A mid yellowish brown silt clay containing frequent small and medium sub rounded flints. This material was used to fill the void left within 806 after the construction of 804		
806	Cut for wall foundations	A linear cut, aligned east-west. Steep straight sides and a flat base. The southern side of this cut has been given a separate number (808) as this may represent the edge of a separate feature.		
807	Natural	A light to mid yellow silt clay containing a very high proportion of small and medium sub rounded flint gravels. Natural drift geology.		
808	Cut for wall foundations	Construction cut – the number given to the southern extent of the cut containing the wall foundation, as well as the possible thinner make up layer to the south of the wall foundation. Steep sided and with a flat base.		
809	Layer	A mid yellowish brown silt clay containing common sub rounded flints. This material was used to fill the void left within 808 after the construction of 804. This has been numbered separately as it may lie within the interior of the building.		

Trench 9	Length: 10m	Width: 1m	Max depth: 0.15m	Ground level: 122.59m OD
Context	Interpretation	Description		

901	Layer	Topsoil. Dark brown silt clay continuing occasional small and medium rounded and sub rounded flint gravels.
902	Layer	A mixed layer of natural subsoils and gravels mixed with dumps of demolition debris covering much of the trench. Probably the result of modern landscaping. There are notable concentrations of modern material, including dumps of domestic and agricultural debris, that may lie within modern cut features.

Trench 10	Length: 1m	Width: 0.6m	Max depth: 0.50m	Ground level: 122.89m OD
Context	Interpretation	Description		
1001	Layer	Topsoil. A dark brown silty clay containing moderate inclusions of fragmentary brick and ceramic building materials with frequent small angular and sub-angular pebbles.		
1002	Layer	Subsoil. A dark greyish brown silty clay containing a high proportion of brick rubble and mortar.		
1003	Layer	Demolition layer. A compact layer of broken brick and mortar, either representing a layer lain as hardcore or generated through demolition of a nearby structure.		
1004	Layer	Dark brown silt clay containing a very high amount of medium and large flint cobbles. This is a layer of rough cobbling at the base of the test pit.		
1005	Cut for wall foundation	The foundation cut for a Victorian churchyard wall. Aligned east-west, it turns northwards at the western end of the test pit. Very steep sided.		
1006	Layer	A dark greyish brown silt loam containing occasional small and medium rounded and sub rounded pebbles. This layer was deposited within the void left in cut 1006 after the construction of 1007.		
1007	Wall	Victorian churchyard wall, built of squares of ashlar and flint lain in a checkerboard fashion Its foundations incorporate frogged bricks.		

Trench 11	Length: 1.1m	Width: 0.9m	Max depth: 0.44m	Ground level: 123.26m OD
Context	Interpretation	Description		
1101	Layer	Modern path. Compact gravel layer		
1102	Layer	Thin band of mid brown silt clay below 1101. Make up layer for modern gravel path.		
1103	Layer	Demolition layer or make up layer comprising compacted crushed brick and ceramic building material. Light grey brown silt clay containing abundant flint fragments.		
1104	Layer	Compact dump of flints in a mid brown clay matrix. Probably a levelling layer.		
1105	Wall foundation	North south aligned flint wall foundation for churchyard wall. Flints lain in a light yellow lime mortar matrix. Fill of 1105.		
1106	Cut for wall foundation	North-south aligned cut for wall foundation 1105. Steep sides and a flattish base. Cuts 1107.		
1107	Wall foundation	East-West aligned flint foundation. Flints lain in a Mid yellow lime mortar matrix. The wall itself is of unfrogged bricks, although these may be re-used. Fill of 1109. Cut by 1106		
1108	Natural	Mid brown clay containing abundant small and medium flint gravels. Natural drift geology.		
1109	Cut for wall foundation	East-west aligned cut for wall foundation 1107. Steep sides and a flattish base.		

Trench 12	Length: 10.2m	Width: 8.25m	Max depth: 1.2m	Ground level: 123.10m OD
Context	Interpretation	Description		
1201	Layer	Modern yard surface/roadway. Very dark grey brown silty clay containing abundant small sub angular and sub rounded gravel inclusions.		

1202	Layer	Levelling layer of demolition material used as hardcore. Very dark grey brown silt clay containing common small sub rounded flints. Seals the remains of the Tudor/Post-medieval building.
1203	Layer	Late Medieval or Post-medieval garden soil. Light to mid grey brown silty clay containing moderate small sub rounded flint pebbles. This layer is cut by the construction of a 'Tudor' or Post-medieval building and seals a number of dated Medieval features.
1204	Wall	Wall of substantial building, aligned east-west. Built of unfrogged bricks lain in a white lime mortar matrix on a stepped brick foundation. The coursing of the bricks is random, and some of the bricks are broken, suggesting that they may have been re-used. Probably contemporary with north south wall 1222 and drain 1228. This wall was later thickened with the addition of 1206.
1205	Brick lined soakaway	Brick lined soakaway within 1229. This comprises a circular revetting wall, one brick thick. The unfrogged bricks are bedded in a white lime mortar. This was constructed within cut 1229, against the face of wall 1206, and represents one of the latest phases of construction, and was presumably built to take run off from roof gutters. The central void contained a gradually accumulated deposit – layer 1209
1206	Wall	Wall aligned east-west. Built of unfrogged red bricks in a white lime mortar matrix. A number of these bricks were broken, and may have been re-used from an earlier structure. This wall was built along the face of wall 1204, effectively thickening it, perhaps as part of a major rebuilding exercise. Some of the foundations of this wall incorporate re-used architectural stones from an earlier building.
1207	Wall	A semi –hexagonal bay window built on to the front of wall 1206 at the eastern end of Trench 12. This may form part of the same general phase of refurbishment, although the evidence at foundation stage suggests that this window was added later. Built in unfrogged red brick in a white lime mortar matrix. It is lain on a flat foundation of flints lain in a white mortar matrix, which is smoothed off to provide a flat upper surface (1210).
1208	Drain	Linear brick lined drain. This comprises a completely enclosed drain, with a base of bricks lain as headers, two walls of bricks lain as stretchers and a capping of bricks lain as headers. Red unfrogged bricks in a white mortar matrix. Some of these bricks appear to have been re-used in the construction of this feature. The drain runs along the eastern face of wall 1222, and appears to have been built into the fabric of wall 1204, suggesting that it was integral to the first phase of construction.
1209	Layer	Fill of soakaway 1205. A mid brown sandy clay containing very occasional small rounded and sub rounded pebbles. Not excavated
1210	Wall foundation	Semi-hexagonal foundation of mortared flint. Medium and large irregular flint nodules lain in a white lime mortar matrix, also some broken brick. The upper surface was smoothed off to create a clean and flat upper surface on which the window (1207) could be built.
1211	Natural	Mid yellowish brown silty clay containing occasional small sub rounded and rounded flints. Natural drift geology.
1212	Pit	Cut of large Medieval pit (or ditch terminus) in the north eastern corner of the site. The visible plan of this feature suggests that it is likely to be sub circular in plan. It had steepish sides and a flat base. It contained two fills, layers 1213 and 1226, and was sealed by the late Medieval garden soil (layer 1203).
1213	Layer	Fill of 1212. Mid grey brown silt clay containing common small sub rounded flints. This forms the upper fill of 1212, and takes the form of a gradually accumulated secondary fill.
1214	Layer	Fill of 1215. Loose dark greyish brown silty sand containing very occasional fragments of ceramic building material and charcoal flecks.
1215	Pit	Cut of sub circular pit with moderately sloping sides and a concave base. Probably dug in the Post-medieval or modern period to contain a tree or shrub.

1216	Layer	Dark greyish brown silty clay containing occasional small and medium sub rounded and sub angular pebbles, with common inclusions of charcoal, ceramic building material and pottery. A mixed dump of material to the west of wall 1222 and to the south of wall 1204, within the building. Patterning of charcoal distribution appears to coincide with gaps in the joists of the room. The deposit itself is likely to be associated with either the construction or demolition of the 'Tudor' or Post-medieval building.
1217	Wall	Semi octagonal bay window. Built of unfrosted bricks lain in a white lime mortar matrix. A more substantial structure than 1207, it was probably added as part of the same phase of improvements – also being built on to the front of 1206.
1218	Layer	Dark brownish grey silty clay containing occasional small and medium sub rounded and sub angular gravels, with common inclusions of charcoal, ceramic building material and brick. A mixed dump of material within the westernmost of the two bay windows (1217). Sealed by a layer of crushed brick (1230) Contains mixed material which is likely to be associated with either the construction or demolition of the 'Tudor' or Post-medieval building.
1219	Pipe trench	Linear cut with very steep sides and a flattish base. Dug to contain a modern metal pipe. Contains a single fill (1220). Cuts 1216 and 1221.
1220	Layer	Fill of 1219. Dark greyish brown sandy silty clay containing very occasional small rounded and sub rounded pebbles. Also contains some charcoal. Mortar flecks and broken and crushed brick and tile.
1221	Layer	Dark greyish brown silty clay containing very occasional small sub rounded and sub angular pebbles. Also contains some charcoal. Mortar flecks and broken and crushed brick and tile. A mixed dump of material to the east of wall 1222 and to the south of wall 1204, within the building. The deposit itself is likely to be associated with either the construction or demolition of the 'Tudor' or Post-medieval building.
1222	Wall	Wall aligned north-south. Built in red unfrosted bricks lain in a white lime mortar matrix. The bonding is irregular, and a number of the bricks used are broken, and may be reused from an earlier structure. Built as part of the original structure, possibly as an external wall. At some time after its construction, the western edge of the wall was modified, with a number of ledges cut in to its southern face, probably to take a series of wooden floor joists (1236).
1223	Layer	Fill of 1224. Greyish brown silty clay. Exposed in a sondage through 1203, it is unclear whether the feature it lies within is a pit or ditch, as the full extent of the feature could not be fully determined.
1224	Pit / ditch cut	Cut of Medieval feature. Revealed in a sondage through layer 1203. Cut into the natural geology, 1211. The full extents and for of this feature were not revealed.
1225	Drain	Brick lined drain. This comprises a completely enclosed drain, with a base of bricks lain as headers, two walls of bricks lain as stretchers and a capping of bricks lain as headers. Red unfrosted bricks in a white lime mortar matrix. Some of these bricks appear to have been re-used in the construction of this feature. The drain runs away from soakaway 1207, on a slight slope. It lies within 1227.
1226	Layer	Primary fill within 1212. Mid yellow brown silty clay containing common small sub angular and sub rounded flint pebbles. This fill is primarily derived from the sides of the feature and the surrounding area.
1227	Cut for drain	Steep sided linear cut for the construction of drain 1225. The full length of this could be traced, although the south eastern end had been somewhat truncated.
1228	Layer	Dark brown silty clay containing very occasional small and medium rounded and sub rounded pebbles. Some charcoal flecks, along with inclusions of mortar, broken brick and ceramic building material. This thin layer of mixed demolition or construction material excavated within the confines of bay window foundation 1217.
1229	Cut for soakaway	Sub ovoid cut dug to contain brick soakaway 1205. Not fully excavated. The creation of this cut and soakaway involved the partial truncation of walls 1206 and 1207
1230	Layer	Layer comprised entirely of crushed brick and ceramic building material. It is unclear whether this represents material from the demolition of the 'Tudor' or Post-medieval building or whether this represents a later layer of make up for a yard surface.

1231	Pit	Number assigned to an irregular ovoid pit dug to contain a tree or shrub as part of a Post-medieval or Victorian planting scheme. The fill was identical to 1202 and may indicate contemporaneity with this. One of a series of similar features.
1232	Pit	Number assigned to an irregular ovoid pit dug to contain a tree or shrub as part of a Post-medieval or Victorian planting scheme. The fill was identical to 1202 and may indicate contemporaneity with this. One of a series of similar features.
1233	Pit	Number assigned to an irregular ovoid pit dug to contain a tree or shrub as part of a Post-medieval or Victorian planting scheme. The fill was identical to 1202 and may indicate contemporaneity with this. One of a series of similar features.
1234	Pit	Number assigned to an irregular ovoid pit dug to contain a tree or shrub as part of a Post-medieval or Victorian planting scheme. The fill was identical to 1202 and may indicate contemporaneity with this. One of a series of similar features.
1235	Pit	Number assigned to an irregular ovoid pit dug to contain a tree or shrub as part of a Post-medieval or Victorian planting scheme. The fill was identical to 1202 and may indicate contemporaneity with this. One of a series of similar features.
1236	Cuts for floor joists	Single number assigned to a series of roughly hewn 'cuts' into the brickwork of 1204 and 1222. Nine of these were exposed during the course of the excavations. They probably mark the position of floor joists. These lay approximately 0.6m apart, although the most southerly two lay some 0.5m apart. The northernmost is cut almost entirely into 1204.

Trench 13	Length: 1m	Width: 1m	Max depth: 0.5m	Ground level: 123.21m OD
Context	Interpretation	Description		
1301	Layer	Topsoil. Dark brown silt clay continuing occasional small and medium rounded and sub rounded flint gravels.		
1302	Layer	Subsoil. Mid grey brown silt clay containing common small sub rounded flints, as well as frequent inclusions of ceramic building material and mortar. A mixed deposit representing an area of levelling in the garden.		
1303	Cut	Cut of ?pit. Much of the western half of the trench contained the remains of this cut. Not fully excavated, but steep sided. The excavated fill contained some 19 th century material.		
1304	Layer	Fill of 1303. Loose deposit – a mid brown silt clay loam containing frequent small sub rounded flints and inclusions of ceramic building material.		

Trench 14	Length: 5.8m	Width: 3m	Max depth: 0.43m	Ground level: 122.71m OD
Context	Interpretation	Description		
1401	Layer	Modern path and make up layers including the grave surface and occasional large flints with occasional brick fragments.		
1402	Layer	A deposit of crushed chalk running east-west along the northern half of the trench. Comprised a thickish layer of heavily compacted crushed chalk, with some flint and brick, as well as some medium to large round pebbles. May represent an old trackway or a foundation/make up layer.		
1403	Natural	Orange natural sand and gravels. Natural drift geology.		
1404	Layer	Brown sandy silt containing a high proportion of small – medium rounded and sub rounded pebbles. Also contains brick, mortar, ceramic building material and charcoal. Occurs as a discrete patch in the south western corner of the trench.		

Trench 15	Length: 3m	Width: 1.2m	Max depth: 0.35m	Ground level: 122.71m OD
Context	Interpretation	Description		
1501	Layer	Topsoil. Dark grey brown loam.		
1502	Layer	Subsoil. Mid grey silty sand containing frequent small sub rounded pebbles and occasional ceramic building material.		

1503	Natural	Mid orange river terrace gravels.
1504	Layer	Cut of modern pipe trench.
1505	Layer	Fill of modern pipe trench. Redeposited material very similar in appearance an character to 1502. A mid grey silty sand.

Trench 16	Length: 4m	Width: 1.2m	Max depth: 0.35m	Ground level: 122.42m OD
Context	Interpretation	Description		
1601	Layer	Topsoil. A dark greyish brown loam.		
1602	Layer	Subsoil. A mid grey brown silty sand containing frequent sub rounded pebbles and occasional inclusions of ceramic building material.		
1603	Natural	Mid orange brown river terrace gravels. Natural drift geology.		

Trench 17	Length: 5m	Width: 1.2m	Max depth: 0.30m	Ground level: 122.58m OD
Context	Interpretation	Description		
1701	Layer	Surface of car park. Compact light grey gravel.		
1702	Layer	Layer of tarmac.		
1703	Layer	Layer f compacted chalk Levelling make up layer for the tarmac surface.		
1704	Layer	Subsoil. Mid orange brown silty sand.		
1705	Natural	Light to mid orange gravel. Natural drift geology.		

Trench 18	Length: 5m	Width: 2.9m	Max depth: 0.60m	Ground level: 122.77m OD
Context	Interpretation	Description		
1801	Layer	Demolition layer. Mid orange brown silty sand containing frequent inclusions of ceramic building material.		
1802	Pit	Pit cut. Circular cut for a pit or well. Not fully investigated, but moderately steep sided where partially excavated. The dimensions of the exposed feature suggests that it would be approximately 3.5m in diameter.		
1803	Layer	Upper fill of pit 1802. A light yellow brown silty clay containing frequent inclusions of ceramic building material and crushed mortar. Dumped deposit of building rubble, possibly associated with the demolition of the 'Tudor' or Post-medieval building in Trench 12 to the north.		
1804	Natural	Mid orange brown silty sand containing occasional sub rounded pebbles.		

APPENDIX 2. SUMMARY OF TREE-RING DATING FOR CHENIES MANOR

BUCKINGHAMSHIRE

CHENIES MANOR

Sample number & type	Timber and position	Dates AD spanning	H/S bdry	Sapwood complement	No of rings	Mean width mm	Std devn mm	Mean sens mm	Felling seasons and dates/date ranges (AD)
Roof above Drawing Room / Blue Room (West Range)									
<i>chny1a</i> c	W queen strut T3	1432-1529	1513	16	98	1.60	0.47	0.173	
<i>chny1b</i> c	ditto	1455-1537	1514	23½C	83	1.33	0.40	0.159	
* <i>chny1</i>	Mean of <i>chny1a</i> + <i>chny1b</i>	1432-1537	1514	23 ½C	106	1.50	0.45	0.166	Summer 1538
<i>chny2</i> c	E queen strut T3	-		H/S	57	1.91	0.59	0.136	
<i>chny3</i> c	Binder between T2 & T3	-		1	87	2.33	1.24	0.234	
<i>chny4a</i> c	1st rafter S of T2 S side	1476-1520	1520	H/S	45	1.23	0.28	0.204	
<i>chny4b</i> c	ditto	1484-1537	1523	14¼C	54	2.15	0.52	0.183	
* <i>chny4</i>	Mean of <i>chny4a</i> + <i>chny4b</i>	1476-1537	1521	13¼C	62	1.74	0.38	0.191	Spring 1538
<i>chny5a</i> c	Tiebeam T2	1392-1524	1498	26	133	1.50	0.67	0.207	
<i>chny5b2c</i>	ditto	1514-1536		+23¼C	23	0.73	0.13	0.168	
* <i>chny5</i>	Mean of <i>chny5a</i> + <i>chny5b2</i>	1392-1536	1498	38¼C	145	1.44	0.68	0.201	Spring 1537
Roof above Stone Parlour / Red Room (West Range)									
* <i>chny6</i> c	N principal rafter T3	1444-1518	1509	9	75	1.97	0.74	0.195	1518-50
<i>chny7a</i> c	S principal rafter T3	1445-1492			48	3.16	1.46	0.227	
<i>chny7b</i> c	ditto	1453-1519	1506	13	67	2.42	1.04	0.189	
* <i>chny7</i>	Mean of <i>chny7a</i> + <i>chny7b</i>	1445-1519	1506	13	75	2.71	1.24	0.191	1515-47
* <i>chny8</i> c	S queen strut T3	1424-1497	(1508)			74 +11 NM		2.19	0.60 0.206 1517-49
<i>chny9</i> c	Tiebeam T3	-		1	52	2.79	2.20	0.215	
Long Gallery Roof (South Range)									
<i>chny11a</i> c	N lower purlin bay 1	1469-1543	1531	12	75	2.73	0.65	0.139	
<i>chny11b</i> c	ditto	1536-1546		+11¼C	11	1.94	0.37	0.157	
* <i>chny11</i>	Mean of <i>chny11a</i> + <i>chny11b</i>	1469-1546	1531	15¼C	78	2.66	0.66	0.142	Spring 1547
<i>chny12</i> c	1st rafter W of T2 N side	-		27C	73	1.42	0.63	0.209	
* <i>chny13</i> c	S interrupted tie T4	1370-1549	1514	35½C	180	1.04	0.56	0.198	Summer 1550

<i>chny14ac</i>	N wall plate bay 9	1477-1545	1522 23	69	1.42	0.57	0.190			
<i>chny14bc</i>	ditto	1486-1549	1524 25C	64	1.53	0.92	0.221			
* <i>chny14</i>	Mean of <i>chny14a</i> + <i>chny14b</i>	1477-1549	1523 26C	73	1.49	0.70	0.192	Winter 1549/50		
<i>chny15 c</i>	4th rafter bay 10 S side	1458-1551	1523 28¼C	94	0.96	0.52	0.207	Spring 1552		
<i>chny16 c</i>	1st rafter bay 10 N side	1448-1551	1522 29¼C	104	0.97	0.52	0.181	Spring 1552		
<i>chny17 c</i>	6th rafter bay 10 N side	1461-1550	1524 26	90	0.96	0.45	0.181	(Spring 1552)		
* <i>chny1567</i>	Mean of <i>chny15</i> + <i>chny16</i> + <i>chny17</i>	1448-1551	1523 28¼C	104	1.05	0.54	0.167			
* <i>chny18 c</i>	S interrupted tie T11	1451-1533	1533 H/S	83	2.48	1.08	0.150	1542-74		
* <i>chny19 c</i>	S principal rafter T12	1443-1550	1528 22½C	108	1.47	0.76	0.214	Summer 1551		
* <i>chny20 c</i>	N interrupted tie T13	1470-1545	1534 11	76	2.32	0.72	0.145	1543-75		
Upper Gallery (West Range)										
<i>chny21ac</i>	E tiebeam	1459-1520	1520 H/S	62	1.87	0.78	0.198			
<i>chny21b1 c</i>		ditto	1471-1488		18	2.28	0.47	0.165		
<i>chny21b2 c</i>		ditto	1487-1502		16	1.68	0.40	0.198		
<i>chny21b3 c</i>		ditto	1500-1519	1519	H/S	20	1.16	0.189		
* <i>chny21</i>	Mean of <i>chny21a</i> + <i>21b1</i> + <i>21b2</i> + <i>21b3</i>	1459-1520	1520 H/S + 18 NM	62	1.90	0.78	0.188	1538-61		
<i>chny22 c</i>	W rafter N side	-	H/S	72	1.61	0.70	0.197			
* <i>chny23 c</i>	N lower purlin	1492-1539	1539 H/S + 11 NM	48	2.75	0.91	0.208	1550-80		
Long Room, Ground Floor (South Range)										
<i>chny24ac</i>	E chimney stack W strut	-		50	1.60	0.96	0.294			
<i>chny24bc</i>	ditto	-		16	1.67	0.54	0.325			
<i>chny24 c</i>	Mean of <i>chny24a</i> + <i>b</i>	-		50	1.58	0.95	0.289			
<i>chny25a1 c</i>		3 rd transverse beam from W					48	2.00	0.77	0.240
<i>chny25a2 c</i>		ditto	-	-	47	0.88	0.43	0.353		
<i>chny26 c</i>	W transverse beam	1480-1531	1531 H/S	52	2.96	1.19	0.226	1540-72		
* = CHENIES1 Site Master					1370-1551	182	1.75	0.46	0.135	

Key: * = sample included in site-master; c = core; ¼C, ½C, C = bark edge present, partial or complete ring; ¼C = spring (ring not measured), ½C = summer/autumn (ring not measured), or C = winter felling (ring measured); H/S bdry = heartwood/sapwood boundary - last heartwood ring date; std devn = standard deviation; mean sens = mean sensitivity, Sapwood estimate used 9 -41 sapwood rings

Ring-width data for site master curve

CHENIES1 AD 1370-1551, Chenies Manor, Chenies, Buckinghamshire - timbers mean of samples - *chny1* + *chny4* + *chny5* + *chny6* + *chny7* + *chny8* + *chny11* + *chny13* + *chny14* + *chny1567* + *chny18* + *chny19* + *chny20* + *chny21* + *chny23*
 182 rings, starting date AD1370

ring widths (0.01mm)	number of samples in master								
116 151 133 127 225 188 184 142 161 136 1	1	1	1	1	1	1	1	1	1
174 172 141 134 89 110 132 144 169 136 1	1	1	1	1	1	1	1	1	1
195 230 210 203 171 255 249 233 264 221 2	1	1	2	2	2	2	2	2	2
242 178 191 186 223 188 178 177 179 155 2	2	2	2	2	2	2	2	2	2
102 118 178 197 152 159 107 113 137 132 2	2	2	2	2	2	2	2	2	2
125 123 118 180 227 227 134 161 210 209 3	2	2	2	2	3	3	3	3	3
160 192 243 188 200 227 209 203 189 165 4	3	3	4	4	4	4	4	4	4
187 202 244 246 233 253 234 240 209 249 8	4	4	4	5	6	7	7	7	8
228 278 258 220 278 240 285 267 241 217 10	8	9	9	9	9	9	9	9	9
211 239 206 231 187 194 226 180 194 190 11	10	10	10	10	10	10	10	10	10
177 169 176 181 191 238 190 152 161 181 14 14 14			12	12	12	12	12	12	13
200 212 212 215 220 195 203 237 217 212 14	14	14	14	14	14	14	14	14	14
216 172 169 175 193 186 229 173 152 160 14	14	14	15	15	15	15	15	15	14
138 135 147 151 158 163 159 158 135 148 14	14	14	14	14	14	14	14	14	14
135 153 163 146 160 143 144 119 165 158 13	14	14	14	14	14	14	14	14	14
138 146 176 130 160 122 148 134 144 121 11	12	11	11	11	11	11	11	11	11
124 168 128 144 138 176 154 153 133 149 7	11	11	11	11	10	10	10	9	7
125 119 88 96 87 114 93 67 73 88 4 4 4			6	6	6	6	6	6	5
74 73			2	1					

Dating of *CHENIES1* against reference chronologies at AD 1551

<u>Reference chronology</u>	<u>Spanning</u>	<u>Overlap</u>	<u>t-value</u>
+ ROMSEY (<i>Hillam and Groves 1994</i>)	1362-1496	112	8.61
+* EASTMID (<i>Laxton and Litton 1988</i>)	882-1981	167	8.61
+ OXON93 (<i>Haddon-Reece et al 1993</i>)	632-1987	167	9.04
+ HILLHAL1 (<i>Bridge 1999</i>)	1425-1564	127	9.01
+ STOLAFS (<i>Miles and Worthington 1997</i>)	1376-1535	151	9.07
+ WC KITCH (<i>Hillam and Goves 1996</i>)	1331-1573	167	9.36
+ COBHSQ01 (<i>Arnold et al 2003</i>)	1317-1662	167	9.54
+ LWYMON2 (<i>Bridge 2001</i>)	1450-1540	91	10.32
+ SOUTH (<i>Hillam and Groves 1994</i>)	406-1594	167	10.59
+ BDLEIAN4 (<i>Miles and Worthington 1999</i>)	1436-1570	116	10.78
+ SENG98 (<i>Bridge 1998</i>)	944-1790	167	10.83
LONDON (Tyers pers com)	413-1728	167	10.90
+ HANTS02 (<i>Miles 2003</i>)	443-1972	167	11.00
+ MASTERAL (<i>Haddon-Reece and Miles 1993</i>)	404-1987	167	11.99

* Component of MASTERAL

Chronologies in **bold** denote regional masters

Bar diagram showing relative positions of dated samples

Long Gallery

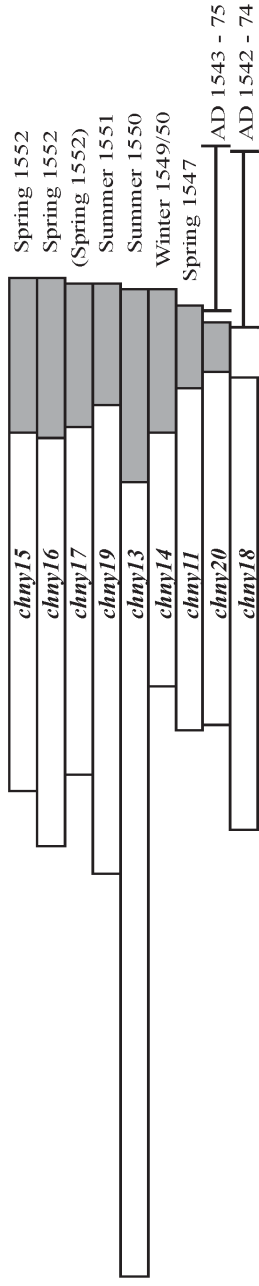

Upper Gallery - Long Gallery access



Roof above Drawing Room / Blue Room



Roof above Stone Par-lour / Red Room



Upper Gallery - Primary Phase

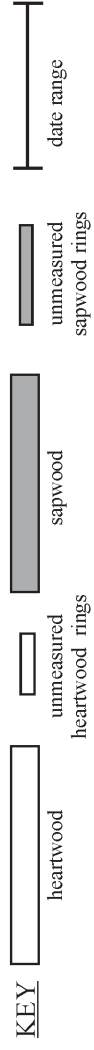

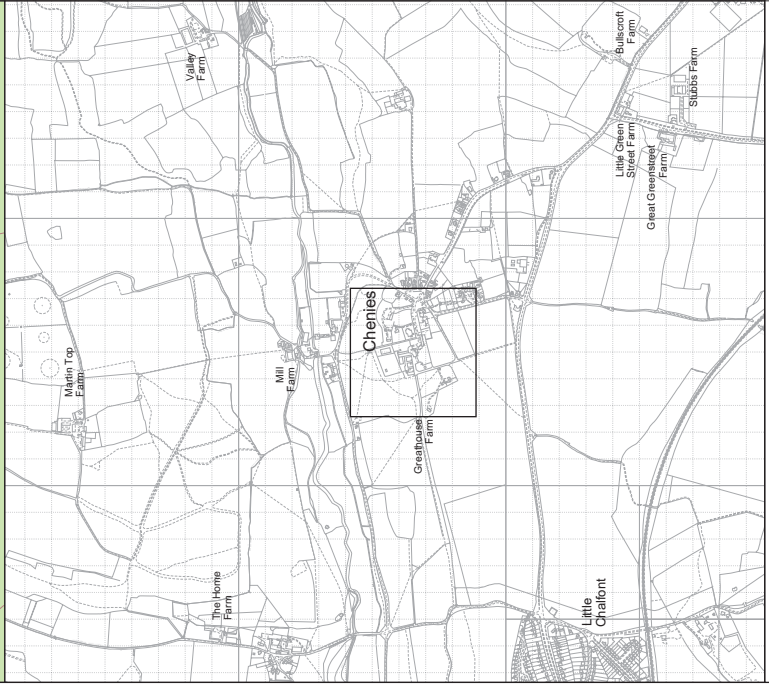
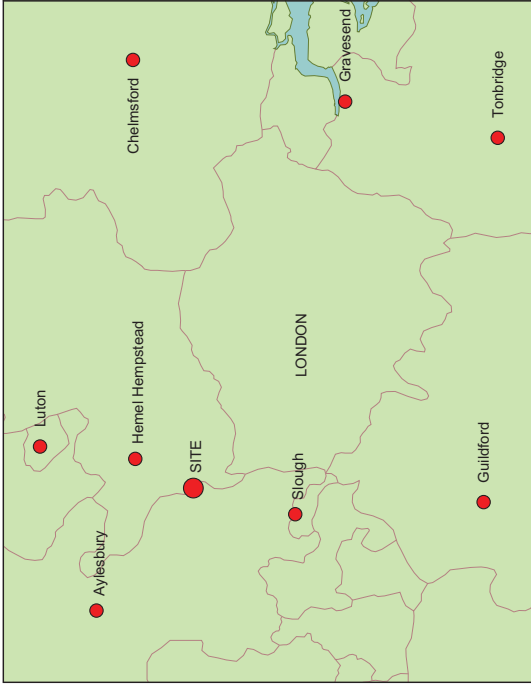

Date:	12/01/05	Revision Number:	0
Scale:	1:2000	Illustrator:	KJB
Path:	Y:\Projects\55751\Drawing Office\Report figures...05-01-12\Figure 1.dwg		

Top inset: Digital Map Data © 2004 XYZ Digital Map Company.
 Digital data reproduced from Ordnance Survey data © Crown Copyright 2004. All rights reserved. Reference Number: AL100018685.
 This material is for client report only © Wessex Archaeology. No unauthorised reproduction.

Site location plan Figure 1



<p>Digital data reproduced from Ordnance Survey data © Crown Copyright 2004. All rights reserved. Reference Number: AL100018665. This material is for client report only © Wessex Archaeology. No unauthorised reproduction.</p>	Date:	12/01/05	Revision Number:	0
	Scale:	1:1250	Illustrator:	KJB
	Path:	Y:\Projects\55751\Drawing Office\Report figures\...05-01-12\Figure 2.dwg		

Plan of the standing buildings of Chemies Manor mentioned in the text

Figure 2

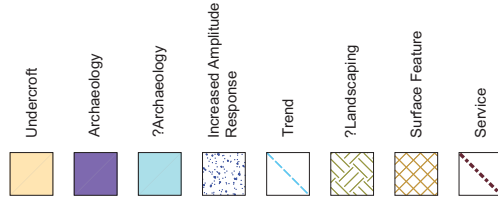

Figure supplied by GSB Prospection Ltd.

Digital data reproduced from Ordnance Survey data © Crown Copyright
2004. All rights reserved. Reference Number: AL100016695.
This material is for client report only © GSB Prospection Ltd and
Wessex Archaeology. No unauthorised reproduction.

Revision Number:	0
Illustrator:	KJB
Date:	12/01/05
Scale:	1:500
Path:	Y:\Projects\55751\Drawing Office\Report figures\...105-01-12\Figure 3.dwg



- High Resistance - Archaeology
- High Resistance - Natural Landscaping
- Low Resistance - Natural Landscaping
- Pipe/Services



Figure supplied by GSB Prospection Ltd.

Digital data reproduced from Ordnance Survey data © Crown Copyright 2004. All rights reserved. Reference Number: AL100016695. This material is for client report only © GSB Prospection Ltd and Wessex Archaeology. No unauthorised reproduction.

Revision Number:	0
Illustrator:	KJB
Date:	12/01/05
Scale:	1:500
Path:	Y:\Projects\55751\Drawing
Office\Report figures...\05-01-12\Figure 4.dwg	

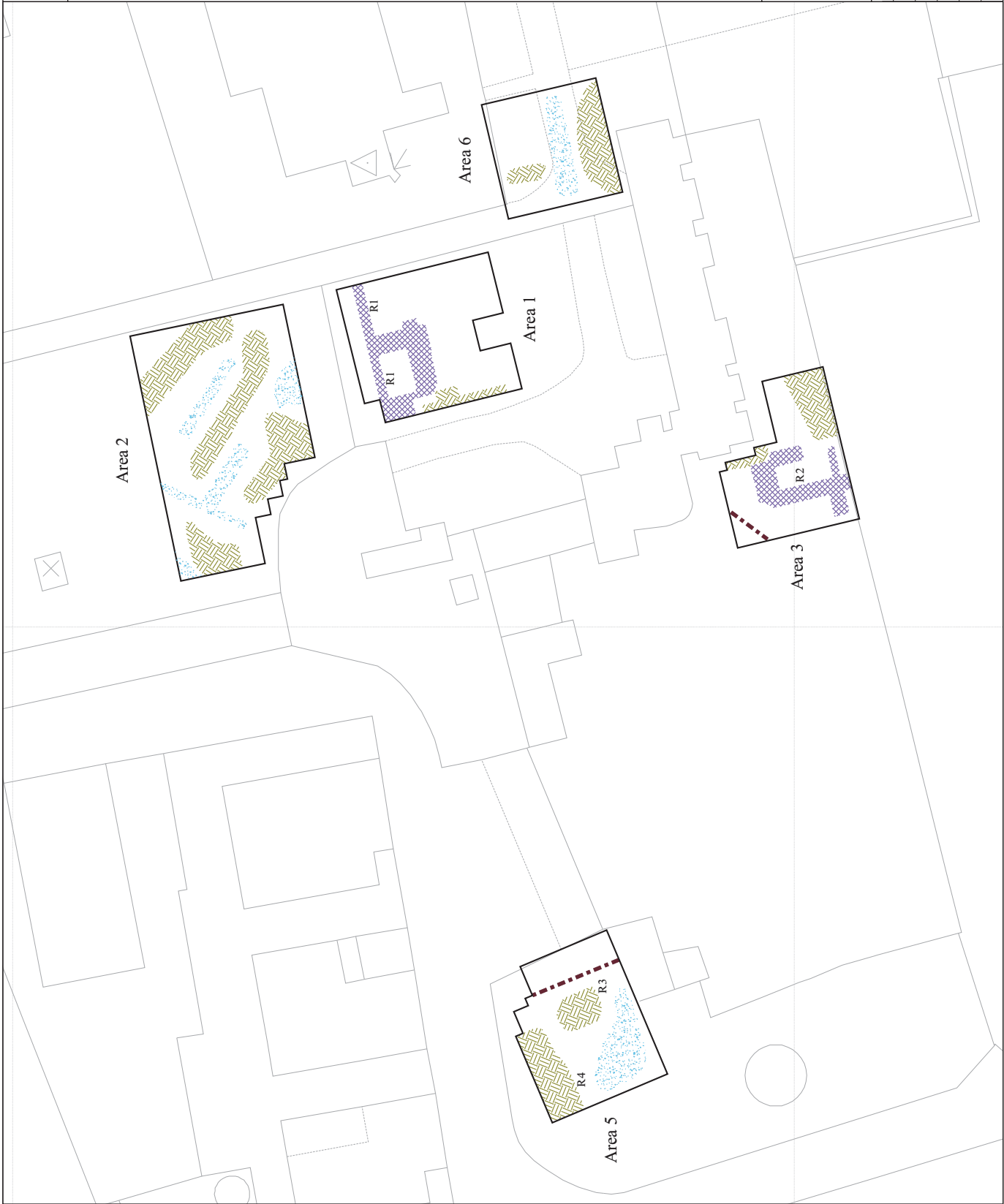



Trench



Digital data reproduced from Ordnance Survey data © Crown Copyright
 2004. All rights reserved. Reference Number: AU100018695.
 This material is for client report only © Wessex Archaeology.
 No unauthorised reproduction.

Revision Number:	0
Illustrator:	KJB
Date:	13/01/05
Scale:	1:500
Path:	Y:\Projects\5575\1\Drawing Office\Report figures\...05-01-12\Figure 5.dwg



Trench layout

Figure 5



- Trench
- Archaeological feature
- Tile
- Brick
- Mortar
- Foundations
- Gravel



This material is for client report only © Wessex Archaeology.

No unauthorised reproduction.

Revision Number:	0
Illustrator:	KJB
Date:	13/01/05
Scale:	plan 1:20, sections 1:10
Path:	Y:\Projects\5575\1\Drawing

Office\Report figures\...05-01-12\Figure 6.dwg

Trench 1

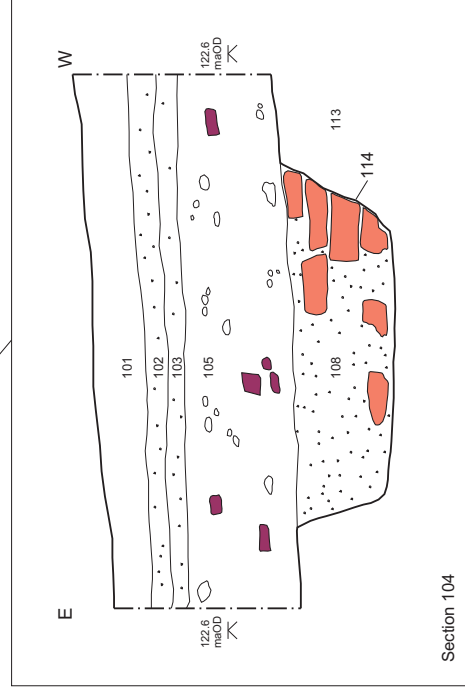
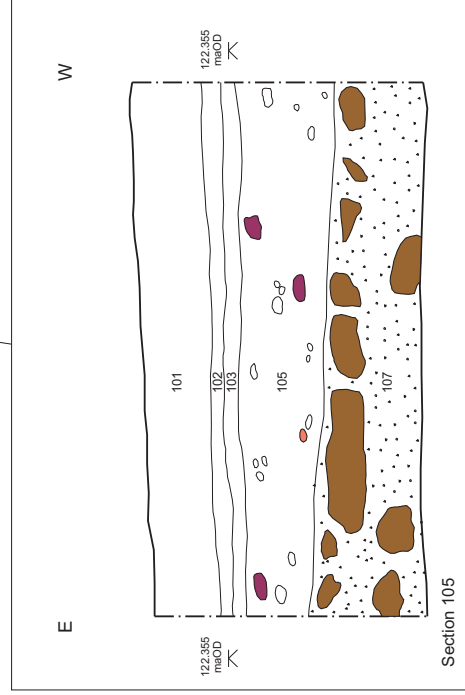



- Trench
- Archaeological feature
- Brick
- Mortar
- Flint



This material is for client report only © Wessex Archaeology.

No unauthorised reproduction.

Revision Number:	0
Illustrator:	K.J.B
Date:	13/01/05
Scale:	plan and section 201, 1:20 section 202, 1:10
Path:	Y:\Projects\65751\Drawing Office\Report figures...05-01-12\Figure 6-9.dwg

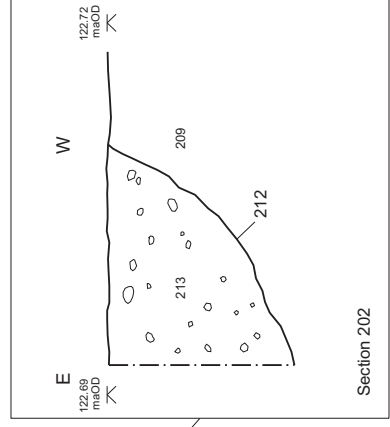
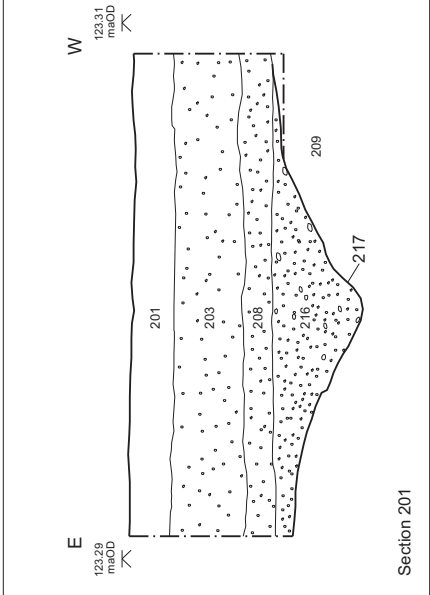



- Trench
- Archaeological feature
- Brick
- Mortar
- Flint
- Gravel



This material is for client report only © Wessex Archaeology.

No unauthorised reproduction.

Revision Number:	0
Illustrator:	KJB
Date:	14/01/05
Scale:	plan 1:20, section 1:10
Path:	Y:\Projects\5575\1\Drawing

Office\Report figures\...05-01-12\Figure 6-9.dwg

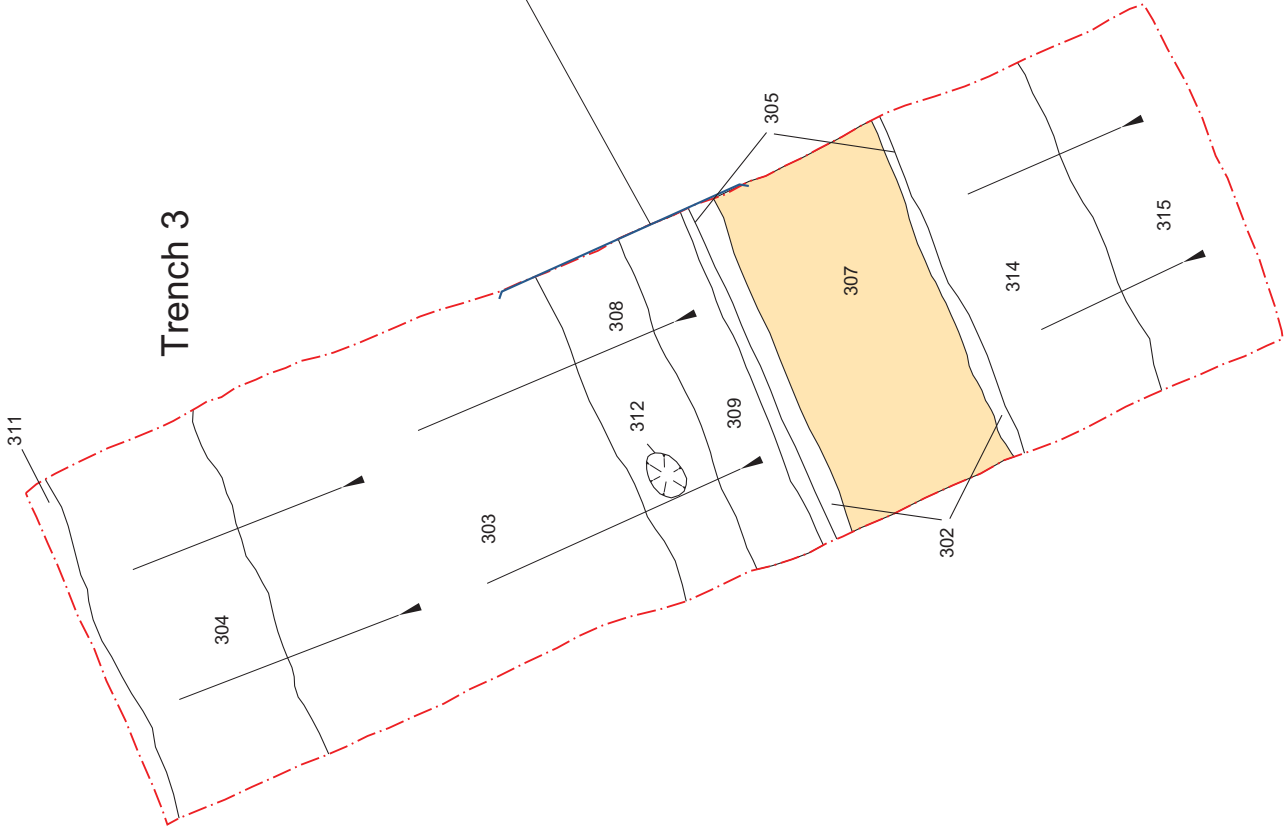
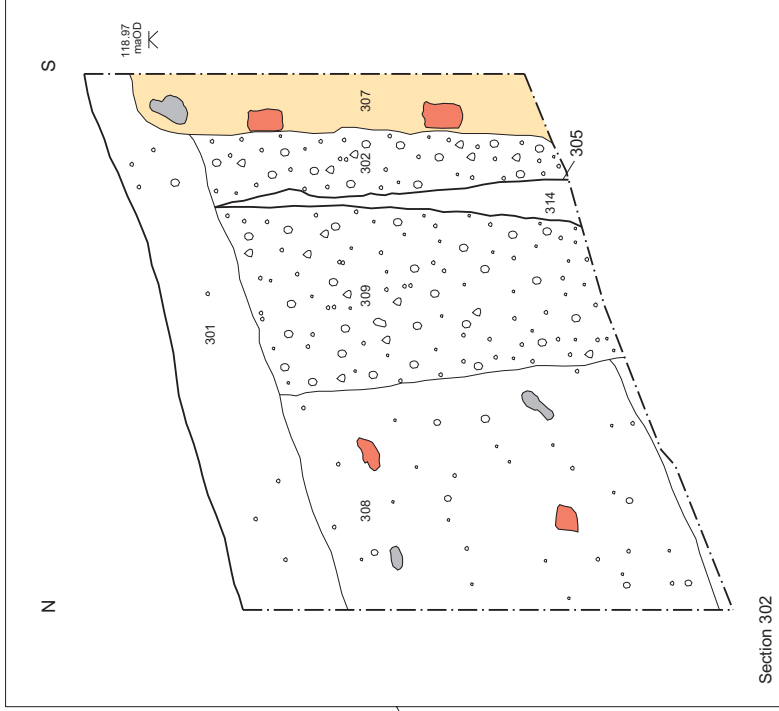

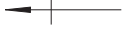

- Trench
- Archaeological feature
- Tile
- Brick
- Mortar
- Flint
- Gravel



This material is for client report only © Wessex Archaeology.

No unauthorised reproduction.

Revision Number:	0
Illustrator:	KJB
Date:	14/01/05
Scale:	plan 1:20, section 1:10
Path:	Y:\Projects\55751\Drawing

Office\Report figures\...05-01-12\Figure 6-9.dwg

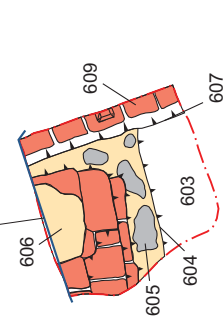
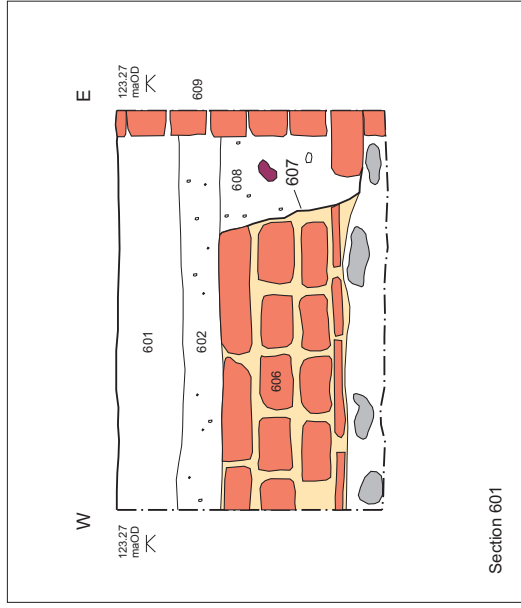
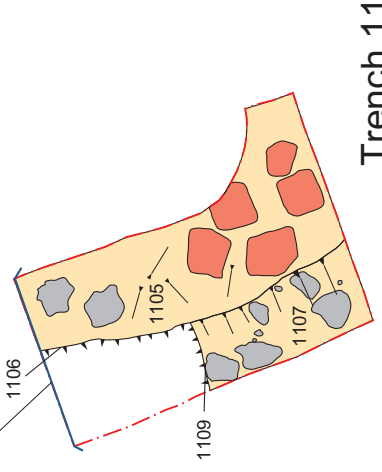
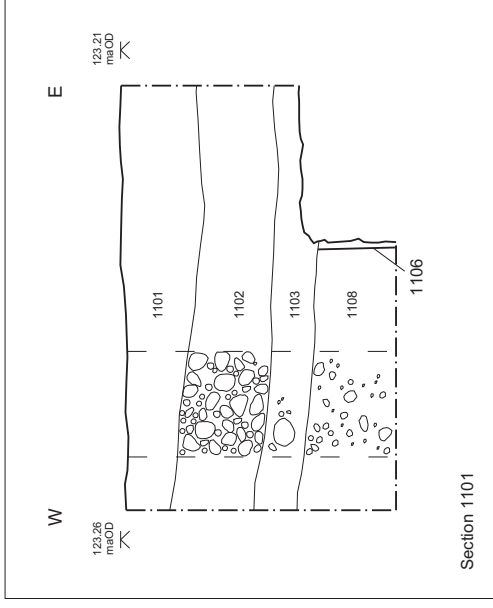

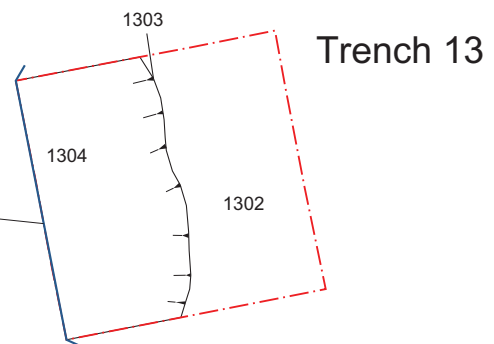
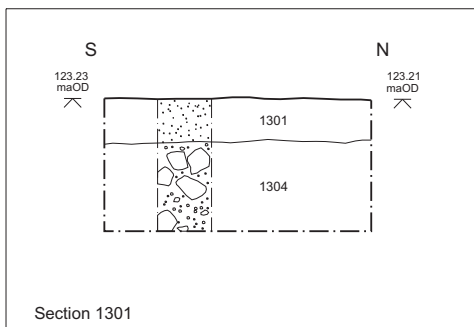
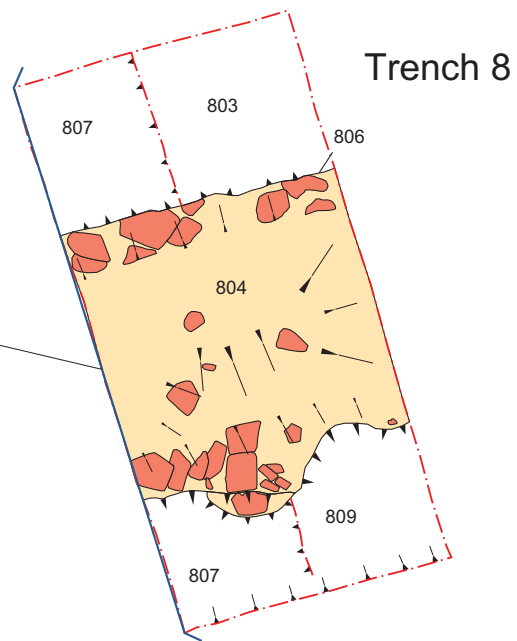
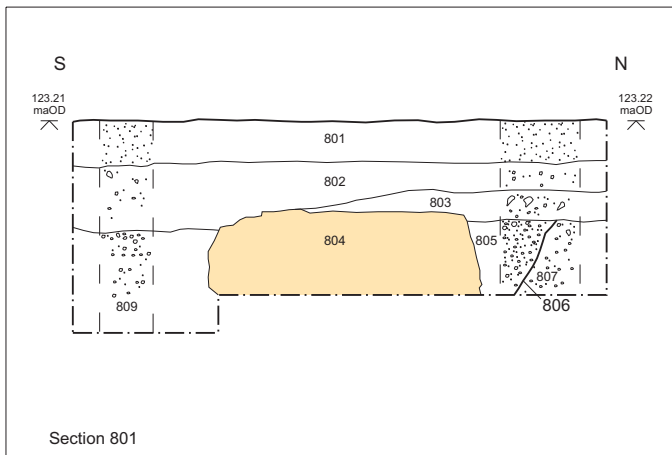
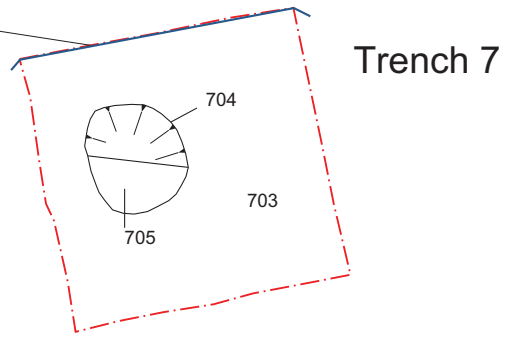
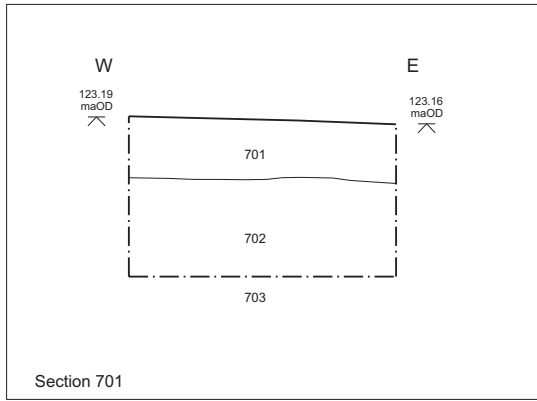

- Trench
- Brick
- Archaeological feature
- Mortar



This material is for client report only © Wessex Archaeology. No unauthorised reproduction.

Date:	17/01/05	Revision Number:	0
Scale:	1:20	Illustrator:	KJB
Path:	Y:\Projects\55751\Drawing office\Report figures...105-01-12\Figure 10-12.dwg		

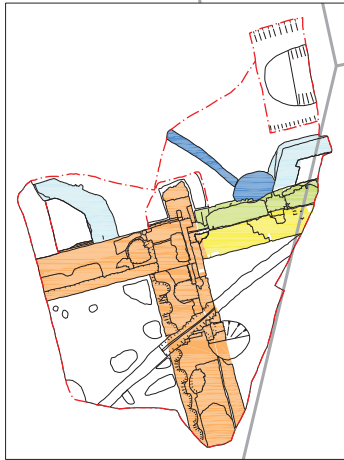
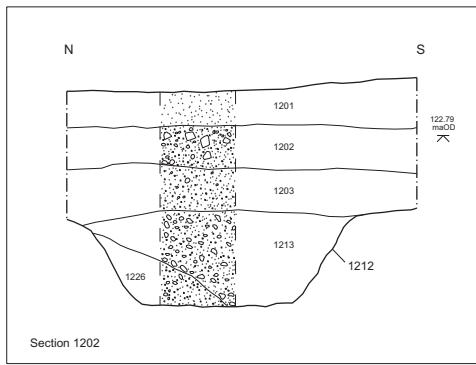

Tudor phasing

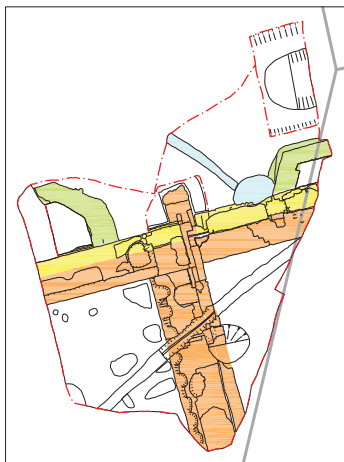

Tudor phasing (alternative)

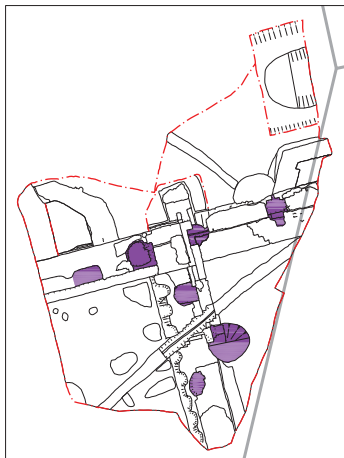

Post-medieval or modern phasing

Key to phasing

- Phase 1 (orange)
- Phase 2 (yellow)
- Phase 3 (green)
- Phase 4 (light blue)
- Phase 5 (dark blue)
- Victorian (purple)

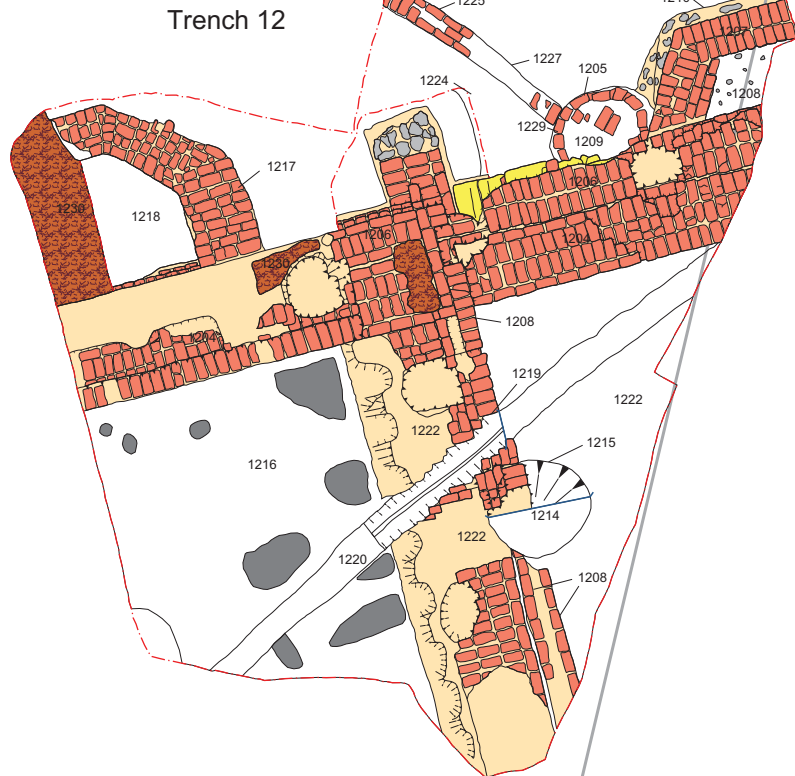

Trench 12

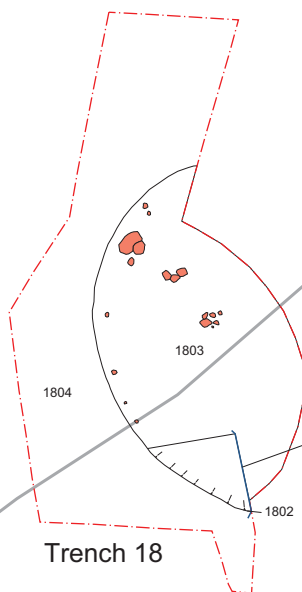

Trench 18

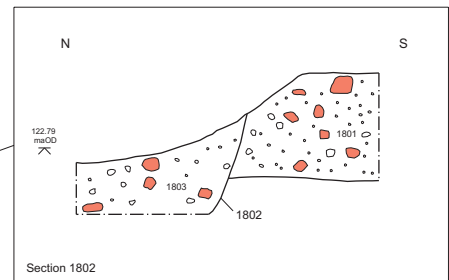

Section 1802

Trenches 12 and 18

Digital data reproduced from Ordnance Survey data © Crown Copyright 2004. All rights reserved. Reference Number: AL100018665. This material is for client report only © Wessex Archaeology. No unauthorised reproduction.

Date:	17/01/05	Revision Number:	0
Scale:	Plan 1:40, sections 1:20	Illustrator:	KJB
Path:	Y:\Projects\55751\Drawing office\Report figures...\05-01-12\Figure 10-12.dwg		

- Trench (red dashed line)
- Archaeological feature (black outline)
- Brick (red)
- Brick rubble (brown)
- Mortar (tan)
- Flint (grey)
- Sandstone (yellow)
- Charcoal (dark grey)

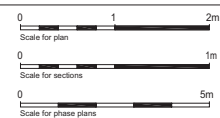
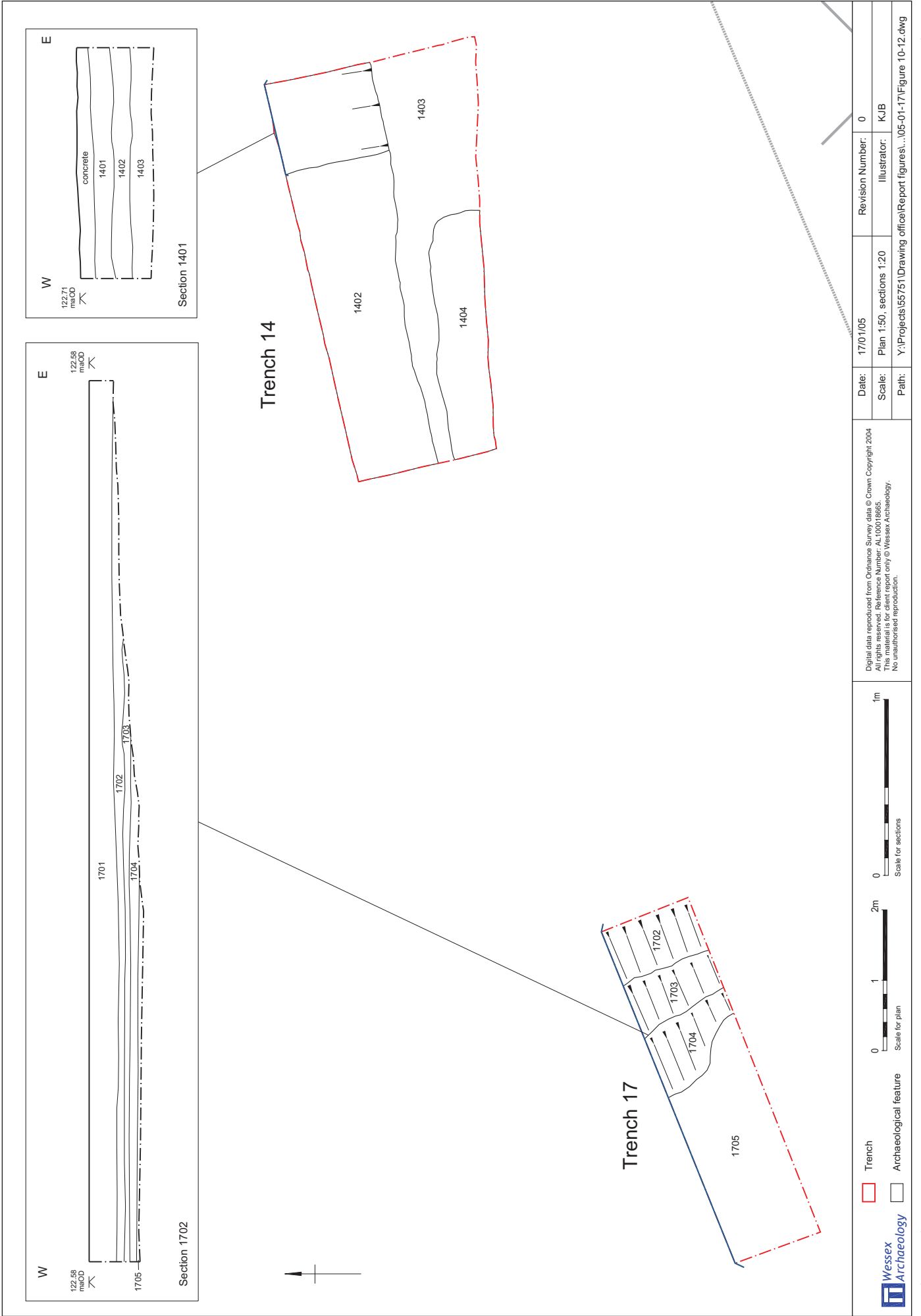

Figure 11



Date:	17/01/05	Revision Number:	0
Scale:	Plan 1:50, sections 1:20	Illustrator:	KJB
Path:	Y:\Projects\55751\Drawing office\Report figures\...105-01-17\Figure 10-12.dwg		

Digital data reproduced from Ordnance Survey data © Crown Copyright 2004
 All rights reserved. Reference Number: AL100018865.
 This material is for client report only © Wessex Archaeology.
 No unauthorised reproduction.

Trenches 14 and 17 Figure 12

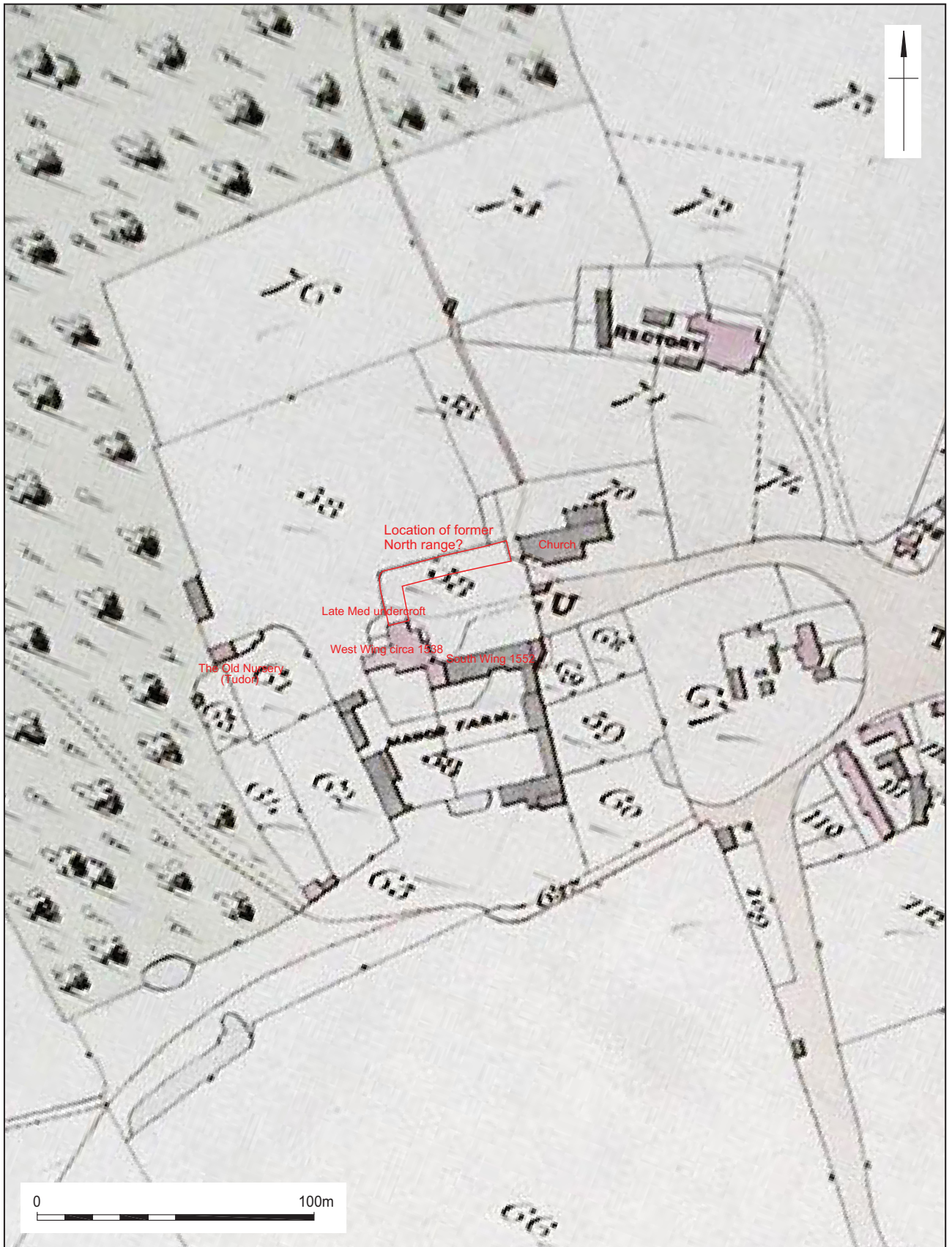

This material is for client report only © Wessex Archaeology. No unauthorised reproduction.			
	Date:	28/01/05	Revision Number:
	Scale:	1:2000	Illustrator:
	Path:	Y:\Projects\55751\Drawing Office\Report figures\...05-01-12\Figure 13.dwg	
			

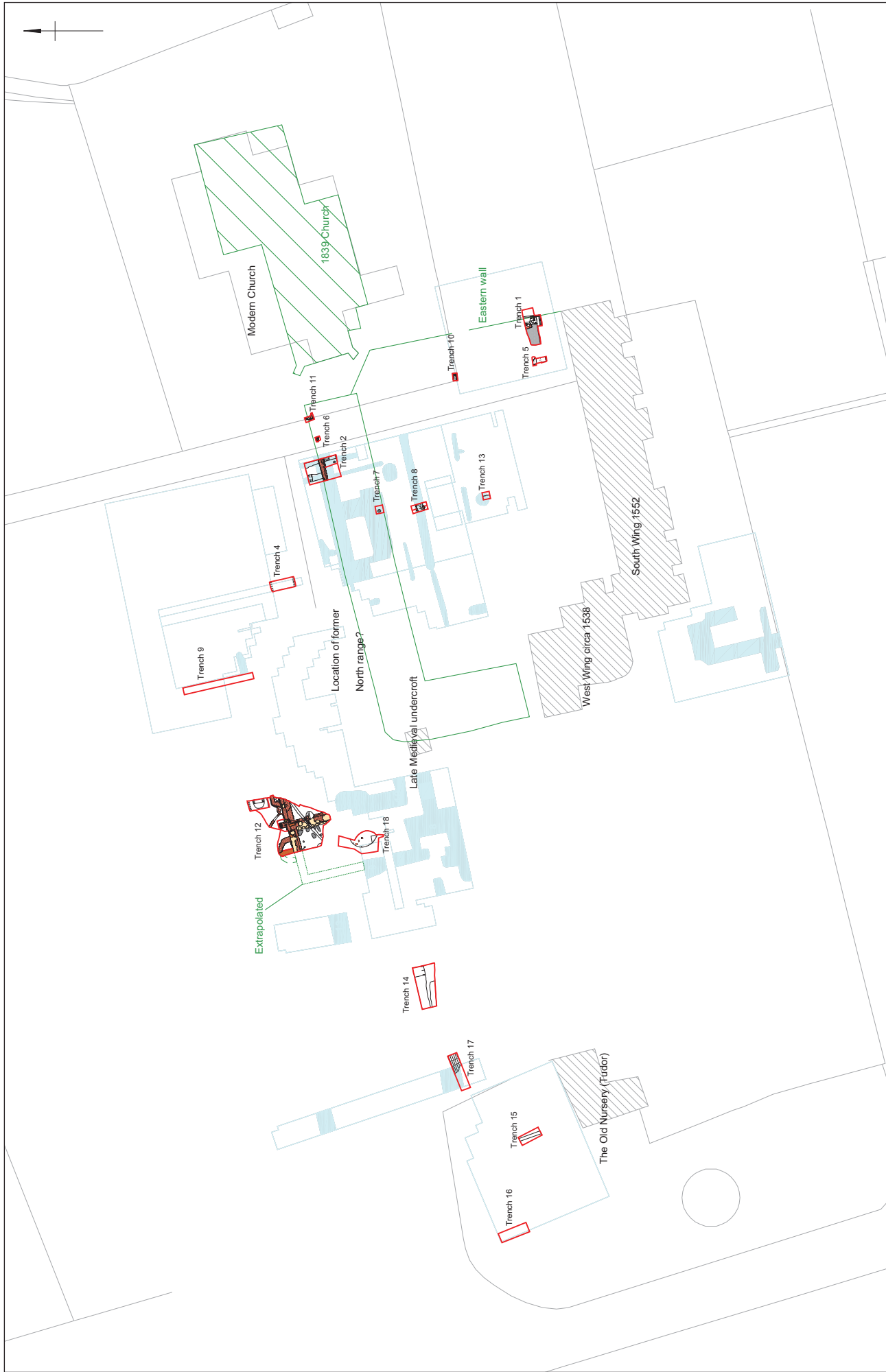

	<input type="checkbox"/> Trench <input type="checkbox"/> Archaeological feature <input type="checkbox"/> Geophysical Survey results <input type="checkbox"/> Evidence from historical mapping	Date: 28/01/05 Scale: 1:500 Path: Y:\Projects\55751\Drawing Office\Report figures\...105-01-12\Figure 14.dwg	Revision Number: 0 Illustrator: KJB
	Reproduced from the (insert date) Ordnance survey (insert scale and map name) map with the permission of the controller of Her Majesty's Stationery Office. Crown copyright, Wessex Archaeology, Forway House, Old Salum Park, Salisbury, Wiltshire, SP4 6EB. Licence Number: AL 10020449. Digital data reproduced from Ordnance Survey data © Crown Copyright (insert year) All rights reserved. Reference Number: 10020449. This material is for client report only © Wessex Archaeology. No unauthorised reproduction.		
	Interpretation of the results of the project		

Figure 14



THE TRUST FOR WESSEX ARCHAEOLOGY LTD.

Head Office: Portway House, Old Sarum Park, Salisbury, Wiltshire SP4 6EB.

Tel: 01722 326867 Fax: 01722 337562 info@wessexarch.co.uk www.wessexarch.co.uk

London Office: Unit 701, The Chandlery, 50 Westminster Bridge Road, London SE1 7QY.

Tel: 020 7953 7494 Fax: 020 7953 7499 london-info@wessexarch.co.uk www.wessexarch.co.uk

