

# ASHBY FOLVILLE TO THURCASTON: THE ARCHAEOLOGY OF A LEICESTERSHIRE PIPELINE PART 1: THE PREHISTORIC SITES

*Richard Moore*

with specialist contributions from:

*Ed McSloy, Lynne Bevan, Alan Vince, James Rackham,  
Jennifer Wood, Ruth Leary*

illustrations by:

*Dave Watt, Lorna Gray, Julian Sleep*

Neolithic, Bronze Age, Iron Age, Roman and early Anglo-Saxon remains were excavated and recorded during construction of the Ashby Folville to Thurcaston gas pipeline. The results from three sites are reported here: sites 10, 11 and 12, which had significant prehistoric remains. Results from the Late Iron Age and Roman sites will be described in part 2, to be published in 2009.

Site 10, near Ratcliffe on the Wreake, included two small pits with a significant assemblage of Neolithic pottery, a Bronze Age ditch and a group of intercutting pits and gullies which produced both Late Bronze Age or Early Iron Age and Anglo-Saxon pottery. Among many undated features, an array of postholes is possibly the remnant of a small post-built structure. At site 11, on the ridge of high ground to the north of Ratcliffe village, the pipeline route intersected part of a system of ditch-defined Bronze Age and Iron Age enclosures. A roundhouse ring gully at site 12, east of Cossington, may date from the Bronze Age.

## INTRODUCTION

Network Archaeology Limited carried out a staged programme of archaeological fieldwork between autumn 2004 and summer 2005 on the route of a new natural gas pipeline, constructed by Murphy Pipelines Ltd for National Grid. The 18 inch (450mm) diameter pipe connects above-ground installations at Ashby Folville (NGR 470311 312257) and Thurcaston (NGR 457917 310535).

The eastern end of the 16km-long pipeline route follows the south side of the valley of Gaddesby Brook, a tributary stream of the River Wreake, before heading north-west to cross the Wreake between Rearsby and Ratcliffe. It then crosses a spur of higher land, either side of the A46 Fosse Way, before dropping again into

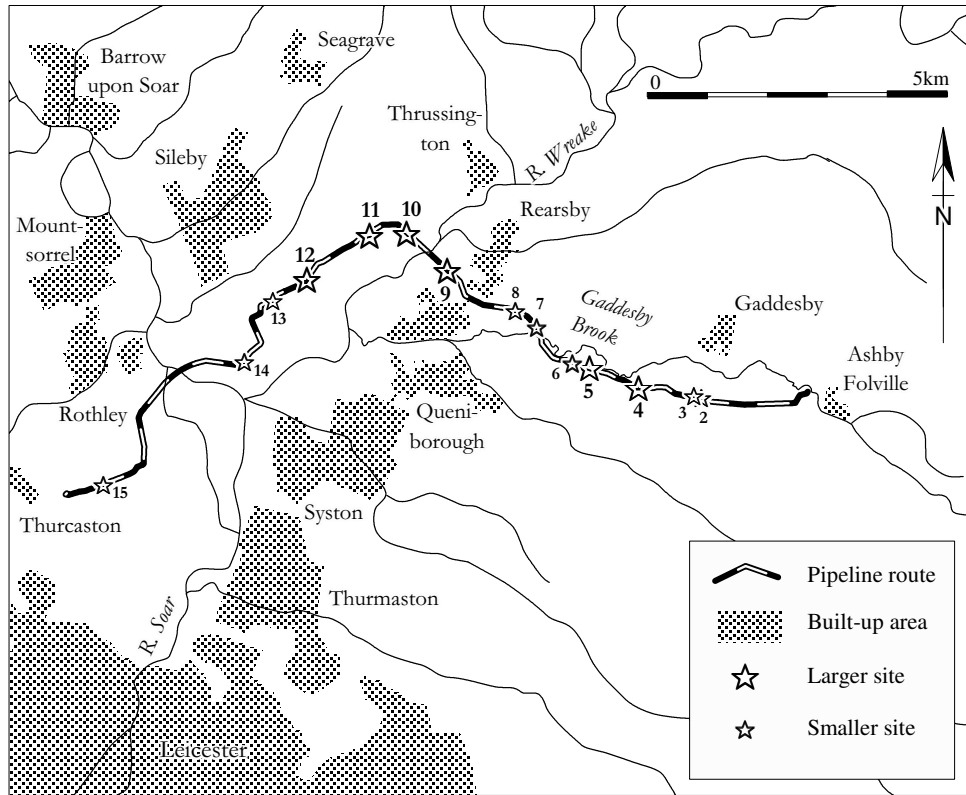

Fig. 1. Location of the pipeline showing archaeological sites.

the valley of the Soar. The western end of the pipeline runs close to the A46 Leicester Northern Bypass (Fig. 1).

Much of the route lies on clay soils overlying glacial till on the higher ground or exposures of the underlying solid geology in the valley sides: Lias clays at the eastern end of the route and Triassic marls to the west (BGS 1974). However, lighter soils have developed over river terrace gravels on the lower slopes of the valleys and over bands of glacial sands and gravels within the till. Alluvium has accumulated in the valley bottoms: a fairly extensive area in the case of the River Soar, and narrower bands beside Gaddesby Brook and the Wreake. Two notable geological formations may be relevant to the archaeology of the area; the route passes very close to the outcrop of Precambrian metamorphic rocks underlying the village of Ratcliffe on the Wreake, and there are extensive granite intrusions at Mountsorrel, 6km to the north of the pipeline.

Prior to the start of fieldwork, a desk-based assessment of the proposed route had been carried out (NAL 2004a). The early stages of fieldwork consisted of non-intrusive surveys: a walkover survey and fieldwalking of arable fields, a metal detector survey, and measured geophysical survey of the route (NAL 2004b). Results of these surveys were used to identify areas for evaluation trenching.

Significant archaeological remains were confirmed on five sites as result of the evaluations (NAL 2005): these sites were then stripped of topsoil, planned and excavated in advance of construction work.

At an early stage in pipeline construction, topsoil is stripped from a working width to create an access track with sufficient space alongside to string out and weld together pipe sections and to excavate and stack the spoil from digging the pipe-trench. In the case of the Ashby Folville to Thurcaston pipeline, the stripped surface was 24m wide, the topsoil being stacked within the remaining 6m of a 30m-wide easement. An archaeologist was present throughout the topsoil stripping, and a further four sites were identified and excavated at this stage.

Excavation of the pipe-trench was also monitored. Monitoring at this stage allows features masked by overlying subsoil or alluvial layers to be observed and recorded. Six further sites of archaeological interest were identified, although the demands of the construction programme and safety considerations limited the amount of investigation that was possible on these sites. In all, fifteen sites were identified during the various stages of work. These were numbered sequentially from east to west along the pipeline route.

Six of the excavation sites, sites 4, 5, 9, 10, 11 and 12, stand out as being of particular significance. Sites 10, 11 and 12 are described below. Sites 4, 5 and 9 were predominantly Roman in date, although both site 5 and site 4 also included significant Iron Age remains. These three sites will be considered in detail in the second part of this article, to be published at a later date. Site 9, between Rearsby and East Goscote, was particularly notable as it contained a 7m-deep stone-lined Roman well, which was fully excavated, producing rich assemblages of artefacts and environmental evidence.

Of the sites of lesser significance, site 6 (NGR 466380 312740), consisting of four ditches and three discrete features, and site 2 (NGR 468560 312145), with several small gullies and pit-like features, both produced small quantities of Iron Age pottery. The other sites produced no dating evidence, although there was a potentially significant feature at site 15 (NGR 458750 310791), a 2.5m long regular rectangular pit with a fill containing fire-cracked stones. This was originally interpreted as a modern feature possibly containing material re-deposited from a prehistoric burnt mound but its similarity to the Anglo-Saxon burnt stone pits found at the barrow cemetery at Cossington (Thomas 2007, 60), 3km to the north-east, prompts speculation that it may have been a comparable, though much less well defined, feature. Details of these sites may be found in the assessment report (NAL 2006).

#### SITE 10: NEOLITHIC, BRONZE AGE AND ANGLO-SAXON FEATURES

##### **Ratcliffe on the Wreake Parish, NGR 463625 314900**

Utilisation of this site, which extended for 85m along the pipeline easement, spanned a wide range of periods, with evidence of Neolithic, Middle and Late Bronze Age, and Anglo-Saxon activity. Features consisted mostly of small pits and

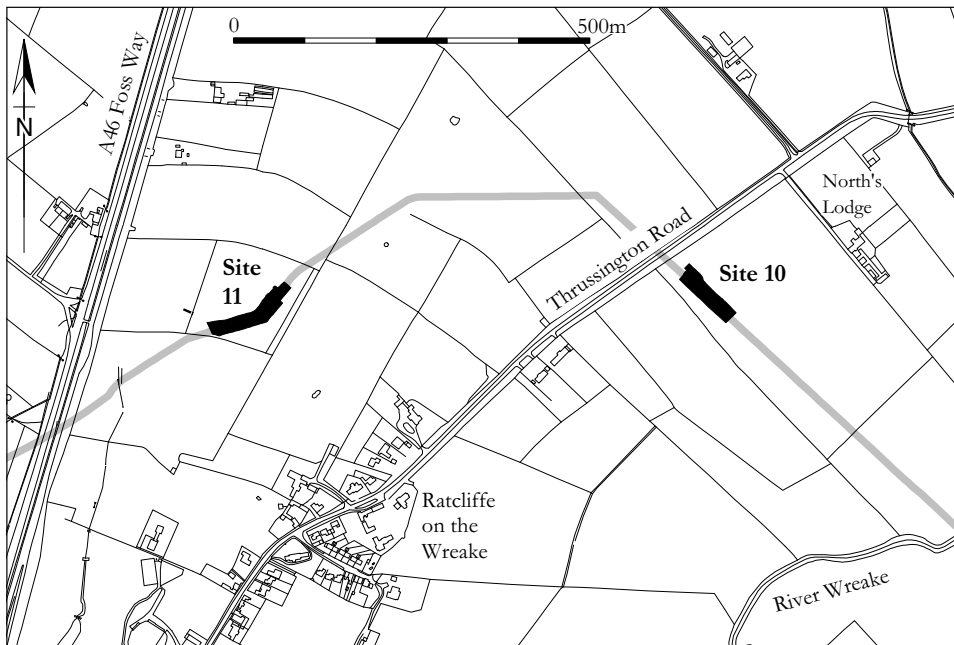

Fig. 2. Location of Sites 10 and 11.

(Mapping reproduced by permission of Ordnance Survey on behalf of HMSO.  
© Crown copyright 2008. All rights reserved. Ordnance Survey Licence number  
100021059.)

postholes, with one large shallow ditch and a number of ill-defined, shallow linear or curvilinear gullies. A rectangular array of 38 postholes or stakeholes near the north-western end of the site appeared to be the remains of a structure. Datable finds were confined to a relatively few contexts and the majority of the recorded features were undated, but several of the individual feature assemblages of pottery were unusually rich, and the site is of considerable significance for this reason.

The site was on relatively flat land, sloping very gently down towards the River Wreake, 300m to the south-east (Fig. 2). The pre-construction geophysical survey noted linear and pit-like magnetic anomalies, and evaluation trenching confirmed the presence of prehistoric features. The area was then stripped of topsoil and excavated in advance of construction (Fig. 3).

### Neolithic features

Two small pits, 2m apart and close to the north-western end of the site (Fig. 4), produced relatively large quantities of pottery and struck flint. The two pits, 48172 (Fig. 5a) and 48188, had slightly different profiles but similar dark grey, charcoal-flecked, silty fills. Cross-matching pottery sherds from the two pits imply that they were closely contemporary, and this was supported by the radiocarbon

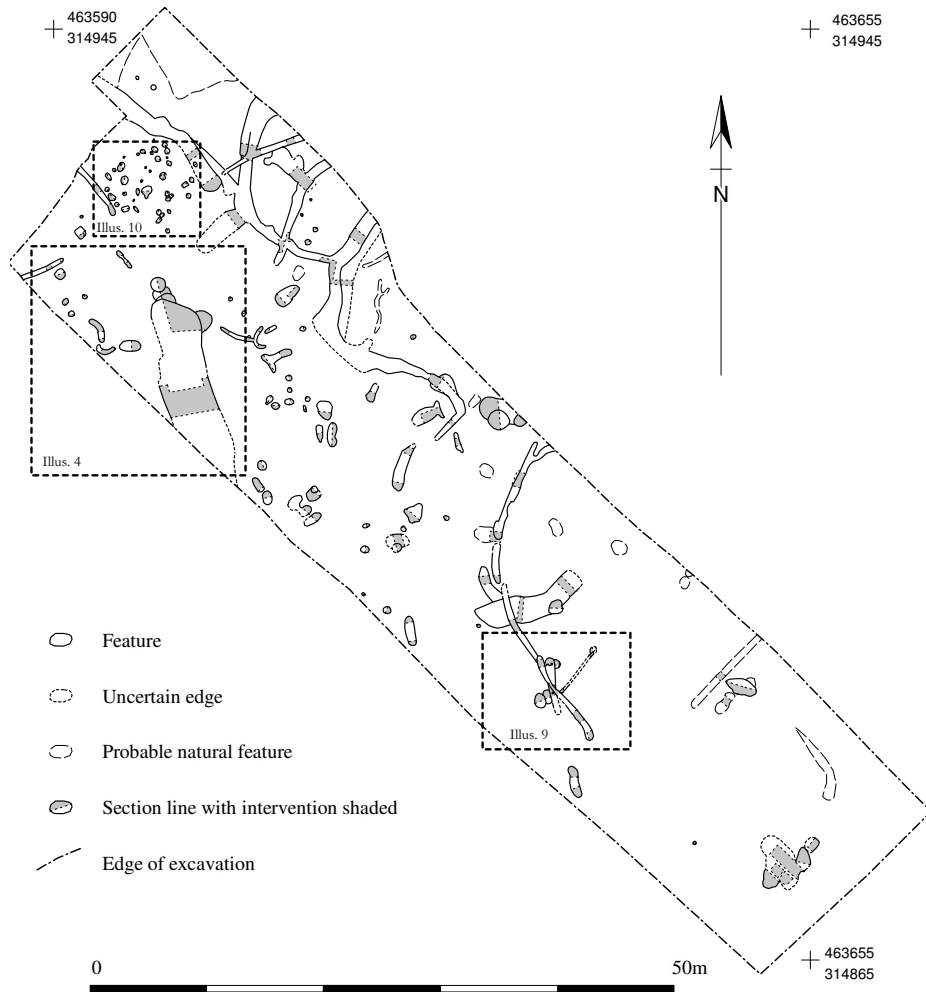

Fig. 3. Site 10, plan of all features.

determinations carried out on four samples. Three samples from the fills of pit 48172 gave radiocarbon dates of 3340 to 3010 cal BC (fill 48171) and 3370 to 3090 cal BC (two samples, from fills 48337 and 48338). A sample from pit 48188 (fill 48383) gave dates of 3120 to 2910 cal BC (81.3% probability) or 3330 to 3210 cal BC (13.0%).

#### NEOLITHIC POTTERY: ED MCSLOY

Though heavily fragmented, the group from these two pits represents a relatively small number of vessels. In total, the 865 sherds retrieved, including 531 from soil samples, weigh 2004g and represent a minimum of twenty vessels. Five vessels were identifiable from portions of the decorated collar zone alone (Fig. 6: 1, 3, 4,

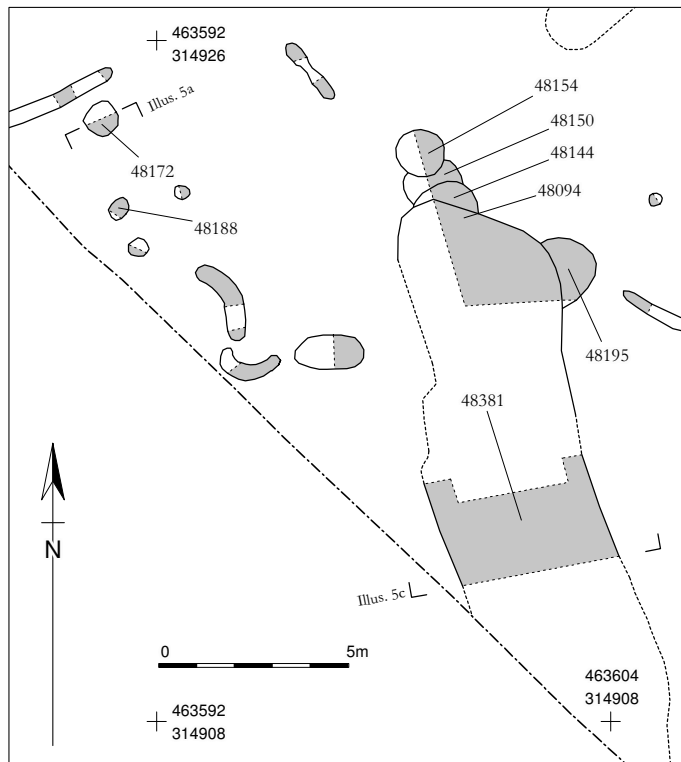

Fig. 4. Location of pits 48172 and 48188 and ditch 48381.

6 and 7) and body or base sherds appear poorly represented. All recovered material is consistent with the Fengate sub-style of Middle Neolithic Impressed wares (Peterborough Ware). The main elements identifying vessels as this style are the decorated rim collars, which in all instances are shallow and curved externally and internally with no internal moulding.

The range of decorative techniques includes incised and repeated impressed designs, reflective of the Peterborough Ware series in general (Gibson and Woods 1997, 224–6). Unusual features include a row of fine impressions, possibly from a comb, over an incised, combed design (Fig. 6: 6), and zones of incised decoration combined with repeated fingernail impressions (Fig. 6: 8). Among the larger vessels, decoration is mainly confined to the collar zone. The lower portion of one vessel (Fig. 6: 2) features splayed fingernail impressions. Decoration to the rim upper takes the form of simple incised or fingernail-impressed motifs including chevrons and zigzags.

Few vessels are reconstructable much below the collar zone; however three vessels (Fig. 6: 1, 3 and 8) exhibit the vase-like forms characteristic of Fengate vessels; with sides narrowing to a narrow base. A single base of this type occurs (Fig. 6: 2). A cup-like vessel (Fig. 6: 5) has shallower proportions in comparison

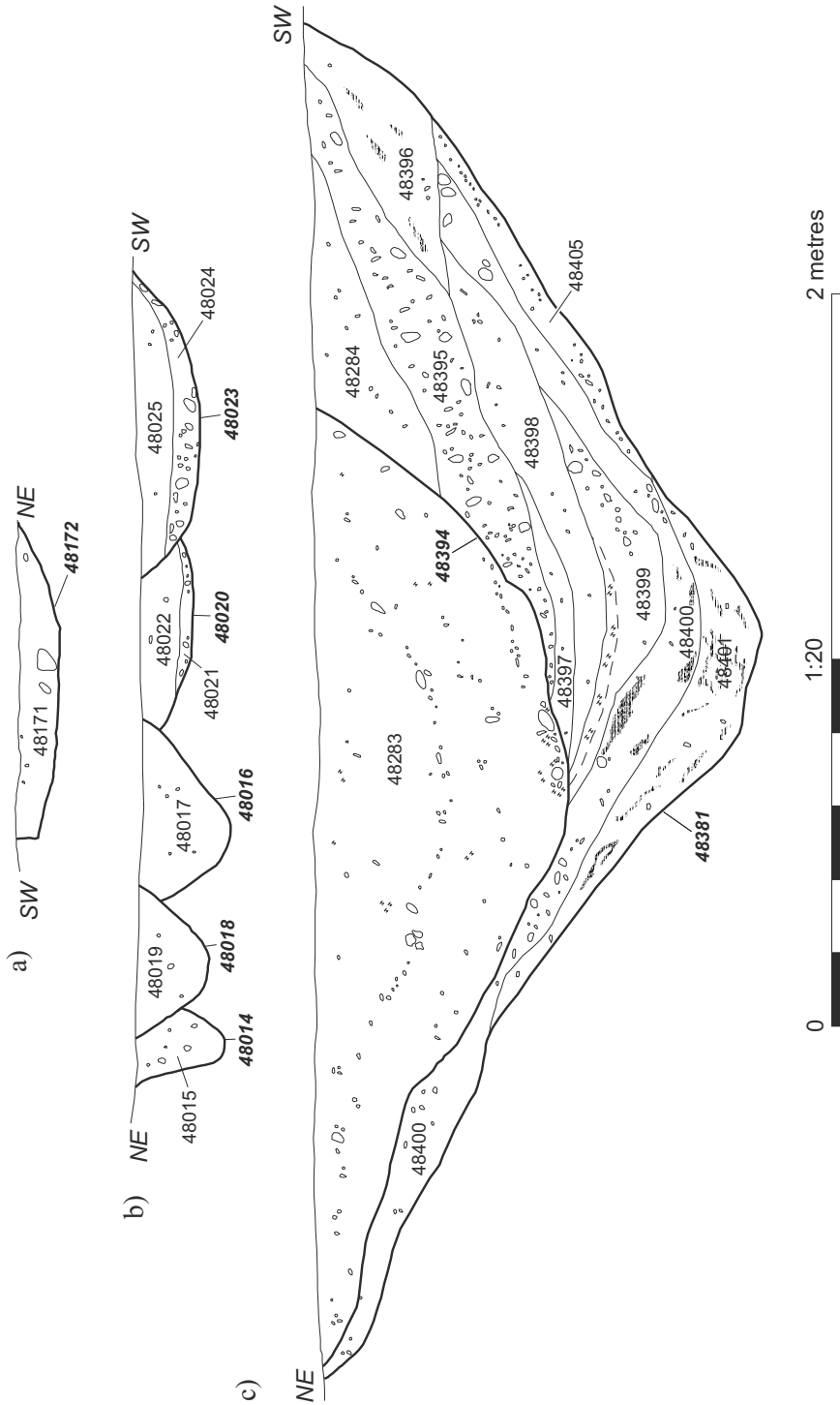

Fig. 5. Site 10 sections.

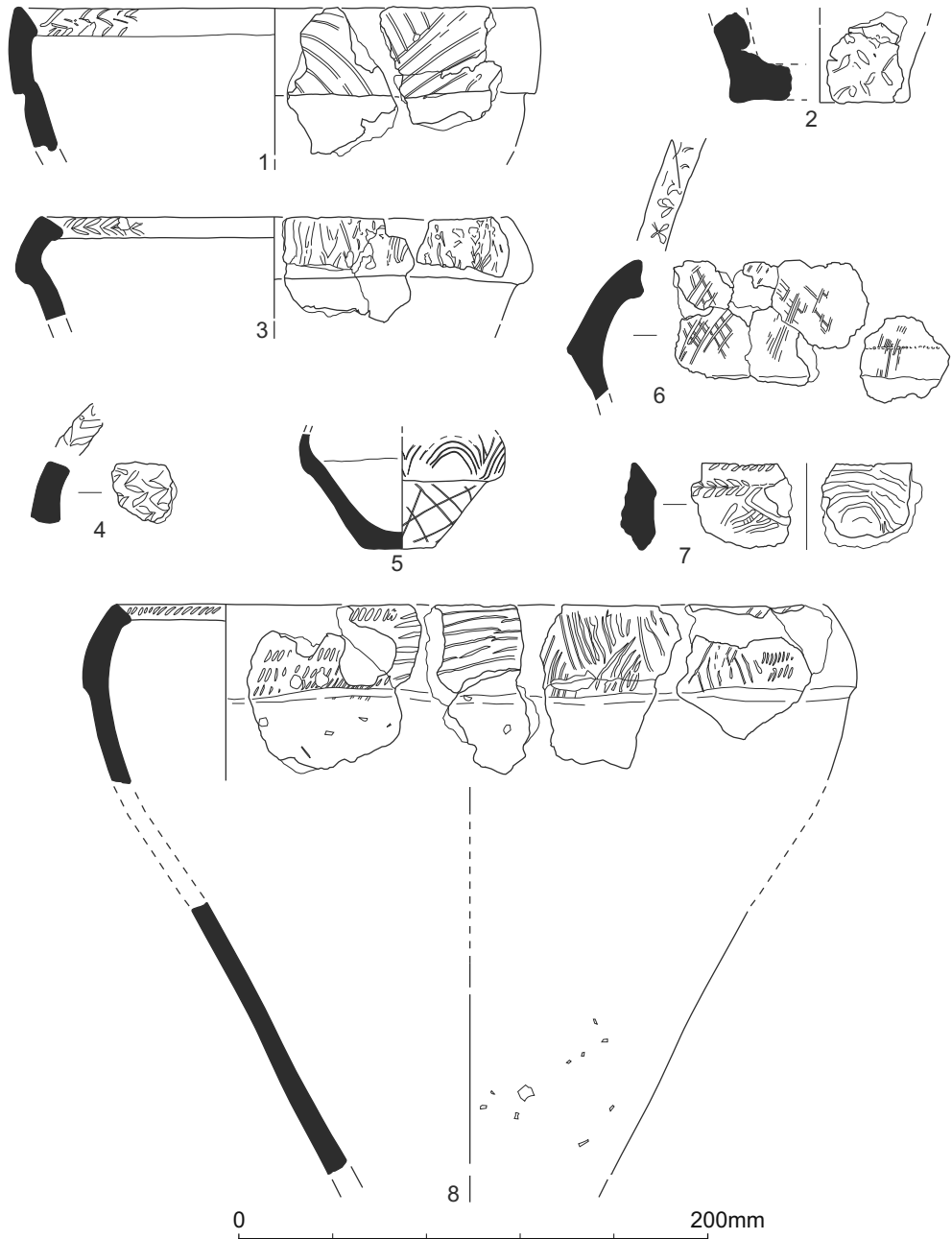

Fig. 6. Neolithic pottery from site 10.



---

1	Collar decorated with incised arc and infilled triangle designs. Bevelled rim with possible incised zig-zag. Est. rim diam. 180mm. Fills 48383, 48187 of pit 48188.
2	Base of vessel. Paired fingernail impressed decoration. Fill 48383 of pit 48188.
3	Strongly incurved collar decorated with incised V designs. Flattened rim with impressed chevrons possibly made with fingernail. Est. rim diam. 160mm. Fills 48383, 48187 of pit 48188.
4	Decoration of paired fingernail impressions forming repeated chevron pattern. Flattened rim with impressed fingernail chevrons. Fill 48383 of pit 48188.
5	Cup. Collar decorated with repeated concentric incised arcs. Body with incised lattice. Rim diam. 80mm. Fill 48338 of pit 48172.
6	Collar with incised, or possibly combed, crosshatch with impressed pointed comb decoration. Bevelled/recessed rim with indistinct impressions probably made with fingernail. Fill 48337 of pit 48172.
7	Collar with incised or possibly combed concentric arc design. Bevelled rim with indistinct impressed chevrons probably made with fingernail, continuing to interior. Fill 48337 of pit 48172.
8	Collar decorated with complex scheme: zones of incised triangles and horizontal lines, and repeated fingernail rows. Rim internally bevelled and decorated with fingernail slashes. Est. rim diam. 300mm. Fills 48337, 48171 of pit 48172. Sherds from pit 48188 probably from same vessel.

---

Table 1. Illustrated Neolithic pottery.

with the larger vessels. Cup-like vessels occur as a minor component within Peterborough assemblages (Thomas 1999, 107); a close parallel, in form if not decoration, is from Ecton, Northamptonshire (Bamford 1975, 16, fig. 8, no. 23).

The date range indicated by the radiocarbon determinations is comparable with the recent re-evaluation of Peterborough Ware chronologies, which places the Fengate sub-style within the range 3500 to 2500 cal BC (Gibson and Kinnes 1997).

The distribution of Peterborough Wares extends across southern Britain and there appear to be no obvious spatial groupings of sub-styles (Thomas 1999, 108, fig. 5.9). Until recently, Peterborough Ware has been lacking from Leicestershire and Rutland (Liddle 1982; Clay 1999) and the Fengate sub-style is not otherwise attested. The location of this group, close to the floodplain of the Wreake, reflects the riverine distribution previously commented upon for the East Midlands, away from the Fen edge (Gibson 1998, 320).

Represented fabrics reflect those for Peterborough Ware generally. Absence of the calcareous fabrics more often typifying Fengate groups is unsurprising, given the local origin suggested by the analysis of the fabrics, carried out by Alan Vince. A group from Oakham, Rutland consists of Mortlake style bowls in ostensibly similar quartz-sand fabrics (Gibson 1998, 318–9). A different chemical composition between the flint tempered and quartz-sand tempered fabrics suggests that these had different origins and opens the possibility of exchange between groups. However the range of inclusions for both fabrics is typical of clays in the East Midlands derived from Triassic sandstones so any such trade is likely to have been very local.

The deposition within smaller, bowl-shaped pits is characteristic of many Neolithic groups (Thomas 1999, 64–74). The high proportion of decorated elements, most often collar zones, with far fewer undecorated body and base sherds, hints at structured deposition, the deliberate placing of significant pieces in the ground. This is characteristic of Peterborough pit groups (*ibid*). The occurrence of a cup (Fig. 6: 5) in a near complete state and deposited inverted may also be significant in this respect.

#### FLINT, SITE 10: LYNNE BEVAN

The assemblage from site 10 included eight cores and core fragments, a fabricator, a scraper, an arrowhead preform, a retouched flake and a serrated flake. Of approximately 300 pieces of struck flint, 180 items, mainly micro-debitage, were recovered from soil samples, two-thirds from the fills of pit 48172. Although not particularly chronologically diagnostic, this small collection appears to have resulted from knapping episodes in close proximity to the pit. The presence of several burnt flakes suggests that this flintworking may have taken place around hearths, with the debitage becoming incorporated in burnt hearth material.

The earliest item in the assemblage is a very small core rejuvenation flake of probable Later Mesolithic date, from which 2mm to 4mm blades have been detached. The early date of the blade core fragment contrasts with the Bronze Age date of an exhausted flake core from the same context (Fig. 7: 11) indicating some degree of contamination or residuality in this assemblage. A retouched flake (Fig. 7: 12) made from the same distinctive speckled grey flint probably comes from the same core and some of the larger items of debitage from this context also appear to be contemporary.

Of the other cores from this site, the earliest is a blade core fragment of probable Late Neolithic date, with one surviving platform from which broad blades have been detached (Fig. 7: 9). A large crystalline inclusion on the reverse and hinge fractures along the platform show that the flint is of poor quality. Cones of percussion above the platform indicate that a hard hammer technique has been used on this item. The same context also produced an ovoid scraper (Fig. 7: 15).

An exhausted flake core similar to illustrated example 7: 11 and probably of roughly the same date was recovered from a soil sample from pit 48188. All of the other core fragments from the site were from flake cores which tend to date to the Later Neolithic to Bronze Age period. Most of the debitage consisted of broad, squat flakes typical of a later prehistoric date (Pitts 1978). A noteworthy item from this pit was a broad serrated flake (Fig. 7: 16). Serrated pieces, usually made on blades, are most often associated with the Early Neolithic period when they appear in quantity (Butler 2005, 130–131, fig. 55: 1–3) but this isolated example, made on a broad flake rather than a blade, may be later.

Other retouched items from the site are from later, or undated, contexts and include a finely-worked fabricator (Fig. 7: 13) and an arrowhead preform, probably for a barbed and tanged arrowhead (Fig. 7: 14). Fabricators are not a generally datable tool since they occur during the Early Neolithic (Butler 2005, fig. 56: 4, 132–133) as well as the Later Neolithic (*ibid*, fig. 71: 10–11, 169 and

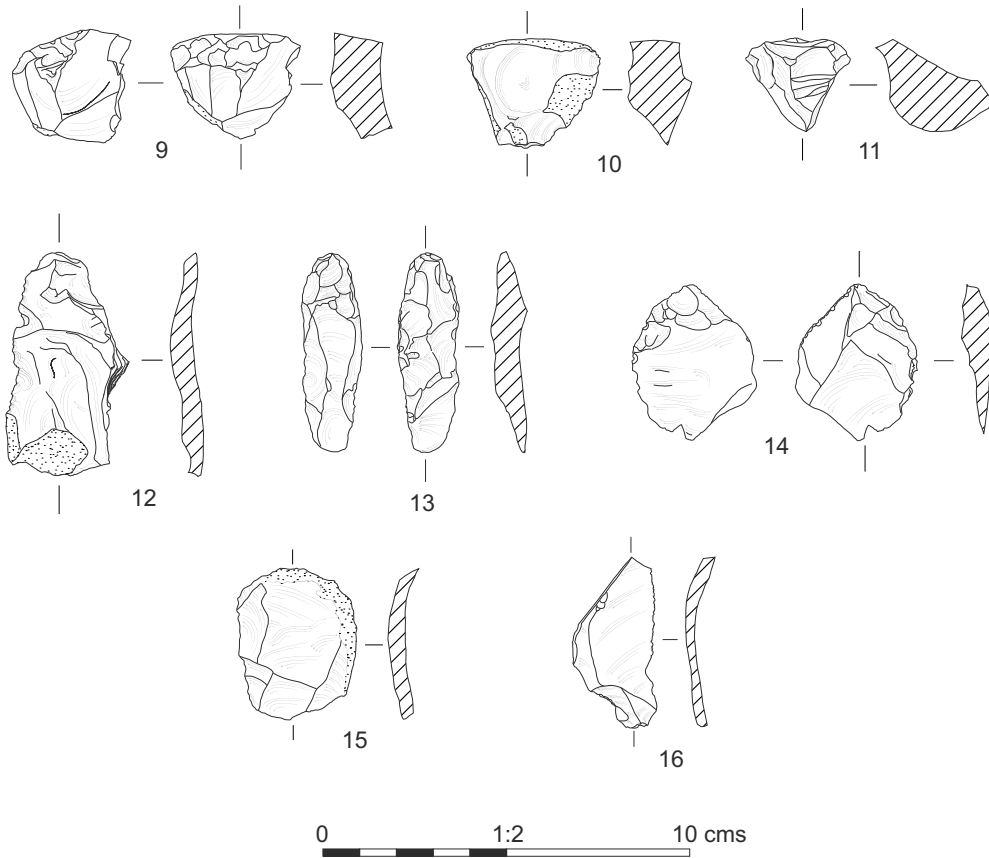

Fig. 7. Flint from site 10.

9	Blade core fragment. Probably Late Neolithic. Light to medium brown, mainly translucent flint. Fill 48171 of pit 48172.
10	Flake core. Light brown translucent flint with white recortication. Probably Later Bronze Age. Fill 48149 of pit 48144.
11	Flake core, with three platforms, totally exhausted and partly burnt. Speckled grey opaque flint. Bronze Age. Fill 48337 of pit 48172.
12	Retouched flake, made on a broad flake which terminates in a deep hinge fracture. Probably from the same core as no. 11 above. Speckled grey opaque flint. Bronze Age. Fill 48337 of pit 48172.
13	Fabricator, with a spatulate end. Light brown translucent flint. Late Neolithic to Bronze Age. Fill 48414 of pit 48411.
14	Arrowhead preform, with pressure flaking on each side. Medium brown translucent flint. Late Neolithic to Bronze Age. Fill 48105 of feature 48106.
15	Ovoid scraper, worked around c. 60% of its circumference. Light grey opaque flint. Late Neolithic to Bronze Age. Fill 48171 of pit 48172.
16	Serrated flake. Dark grey-brown translucent flint. Neolithic to Bronze Age. Fill 48383 of pit 48188.

Table 2. Illustrated flint from site 10.

174) and throughout the Bronze Age (*ibid*, fig. 76: 11–12, 186–187). A small exhausted flake core with three platforms, two of which have been worked from opposite directions on one side (Fig. 7: 10), had been flaked through its partially recorticated surface, indicating decortication followed by re-use in a later period.

### Middle Bronze Age

Ditch 48381 was a substantial feature and seems to have been maintained for some time, at least one re-cut, 48394, being visible (Fig. 5c). The undifferentiated fill of this re-cut produced 69 sherds of pottery, and a sample from this fill gave a radiocarbon date of 1420 to 1250 cal BC (91.6% probability) or 1240 to 1210 cal BC (3.8%). A sample from a fill of the original ditch gave an overlapping or slightly earlier date: 1500 to 1470 cal BC (1.3%) or 1460 to 1290 cal BC (94.1%). Two circular pits, 48195 and 48144, cut by ditch 48381, produced pottery that was broadly similar, if less diagnostic, and it is likely that these too dated from the Middle Bronze Age.

Soil samples taken from ditch re-cut 48394 and pit 48195 were among the few from the site to produce charred plant remains. The presence of emmer wheat and hulled barley is consistent with results recorded on other Bronze Age sites.

#### MIDDLE BRONZE AGE POTTERY: ED MCSLOY

Pottery derived from the fills of ditch 48381 and its re-cut 48394, and from the pits close to the terminal of this ditch, could be confidently dated to this period (Fig. 8: 18). Most material is a distinctive coarse acid igneous rock-tempered fabric. Vessel thickness, in excess of 15mm, and the occurrence of an applied, fingertip impressed strip (Fig. 8: 17), suggests a Deverel-Rimbury related Middle Bronze Age urn tradition. The radiocarbon determinations support the Middle Bronze Age dating and are consistent with the dating of other sites in the region with Deverel-Rimbury style associations (Knight 2002, 123).

Forms represented in this small group are consistent with what is known of Middle Bronze Age ceramic styles in the East Midlands (Knight 2002, 123). Comparable material is identified primarily from funerary sites including Barwell, Leicestershire (Allen *et al.* 1987, 330) and Coneygre Farm, Thurgarton, Nottinghamshire (Allen *et al.* 1987, 194–9, figs. 6–10). The East Midlands material, including groups described here, would seem to represent a regional expression of south British Deverel-Rimbury style, where forms consist of larger barrel- or bucket-shaped vessels with decoration in the form of applied strip or finger-impressions occurring only rarely. Grog appears to be usual means of tempering for the region. The granitic fabrics represent an early use of materials more often associated with later prehistoric assemblages (Knight *et al.* 2003). The source of the granite inclusions is likely to be Mountsorrel granodiorite (Hains and Horton 1969, 27).

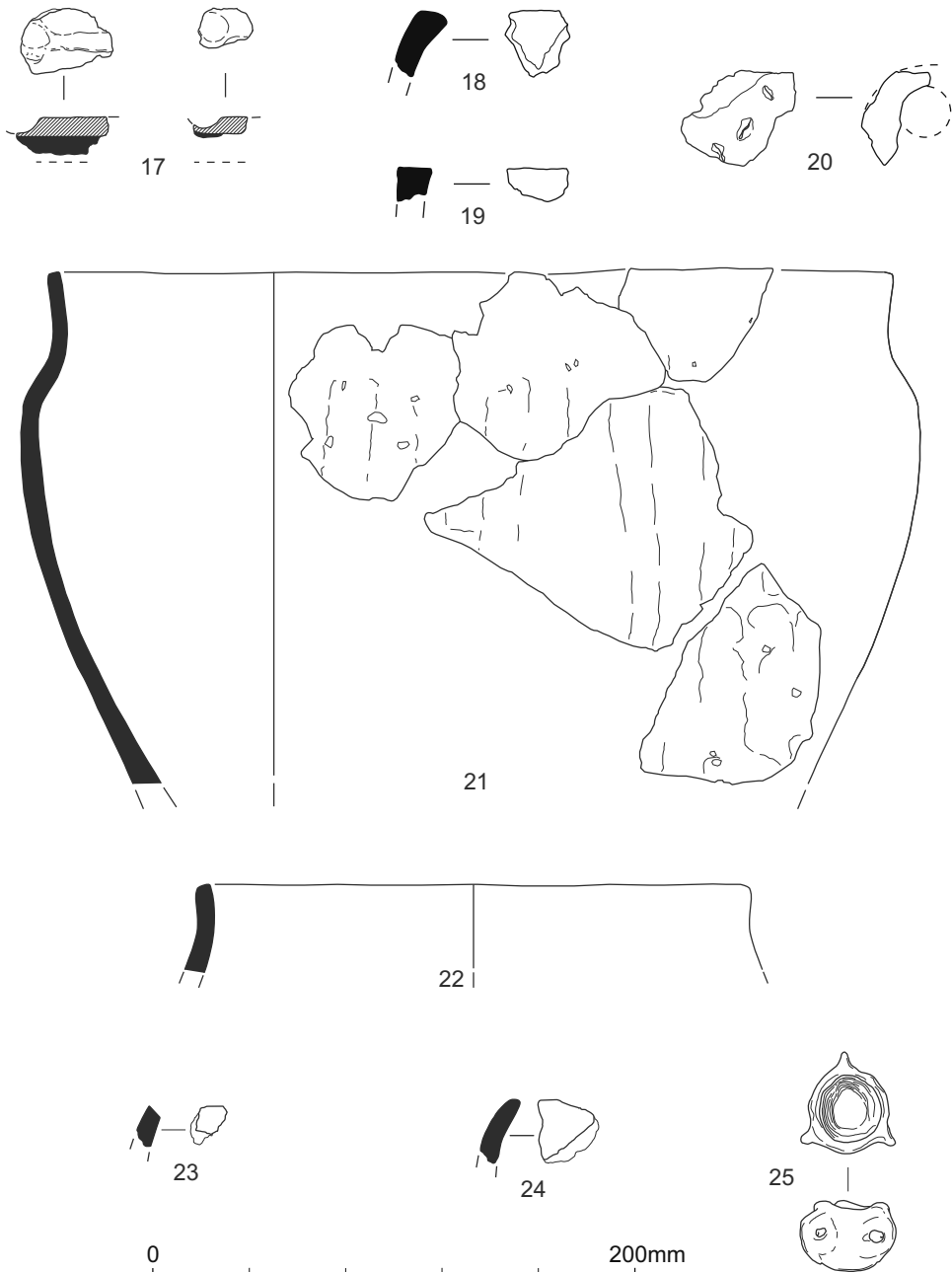

Fig. 8. Bronze Age and Anglo-Saxon pottery from sites 10 and 11.

---

17	Sherds comprising applied (17a) and possibly pinched out (17b) strip decoration with fingertip impressions. Fill 48283 of ditch 48006.
18	Rim from probable barrel urn. Fill 48149 of pit 48144.
19	Squared rim from probable bucket urn. Fill 54009 of ditch 54000.
20	Fragment from possible cylindrical weight, or other ceramic object, with fingernail impressions. Fill 54005 of ditch 54000.
21	Large, round-shouldered jar with high neck and squared rim. Undecorated but with finger-wiped surfaces. Est. rim diam. 300mm. Fill 48007 of pit 48006.
22	Round-shouldered jar with high neck and squared rim. Undecorated but with horizontal smoothing apparent to the neck. Est. rim diam. 210mm. Fill 48022 of pit 48020.
23	Ovoid jar with incurved, undifferentiated, rim which is rounded. Fill 48022 of pit 48020.
24	Ovoid jar with incurved, bevelled rim. Fill 48017 of ditch 48016.
25	Complete miniature vessel with pinched out tri-form lugs, horizontally perforated. Sandy fabric. Rim diam. c. 33–34mm. Fill 48025 of pit 48023.

---

Table 3. Illustrated Bronze Age and Anglo-Saxon pottery.

### Late Bronze Age to Early Iron Age

Late Bronze Age activity seemed to be concentrated around a group of features towards the south-eastern end of the site (Fig. 9). Pit 48006 survived to a depth of only 0.08m and its eastern side was truncated by a steep-sided gully, probably a post-medieval drain, but its dark silty fill contained a high proportion of pottery, 256 sherds in total. Pit 48020, 5m to the south-west, was only identified clearly in section (Fig. 5b), where it appeared to be a small, flat-bottomed feature. It was cut on its east side by ditch 48016, which had three stakeholes in its base, suggesting that it might have had a structural function.

A small, curvilinear gully, 48018 cut through these features. Samples from several interventions through this gully contained hammer-scale, implying that iron-smithing was being carried out nearby at the time that the very dark, silty backfill of the feature was accumulating. They also showed an increase in remains of spelt wheat and a decline in emmer, a pattern typical of Iron Age assemblages.

The line of this curvilinear gully appeared to continue to the west and north forming a circular arc of poorly defined elongated pits or gully sections. Its appearance in plan suggests that this could have been the heavily truncated remains of a roundhouse ring gully, but its diffuse edges in the excavated interventions meant that it could not be clearly characterised and it produced no dating evidence.

#### LATE BRONZE AGE TO EARLY IRON AGE POTTERY: ED MCSLOY

This group is notable for a substantially complete large jar from pit 48006. (Fig. 8: 21). This pottery is comparable with the post-Deverel-Rimbury, undecorated phase of the Late Bronze Age, first recognised from southern Britain (Barrett 1980), but increasingly known from the eastern region (Knight 2002, 124–6) including a number of sites in the central eastern region (Clay 2001, 3–4). Several dating programmes have placed it between around 1200 and 900 cal BC.

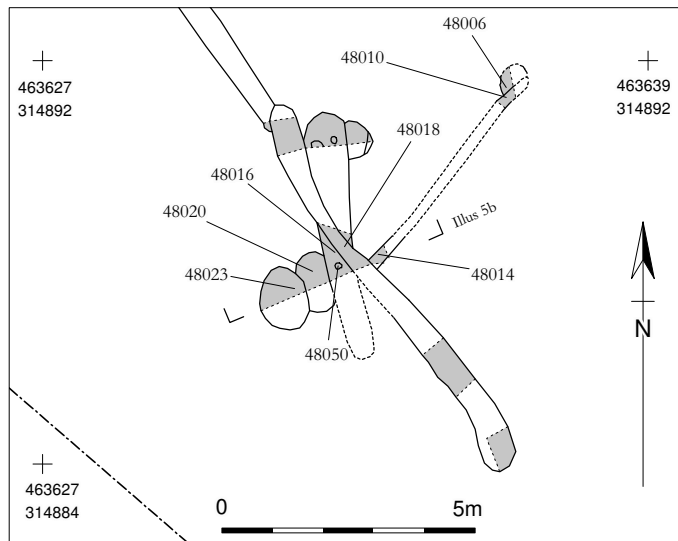

Fig. 9. Features with later pottery, site 10.

Vessel forms comprise high-necked shouldered jars (Fig. 8: 21–22) and ovoid jars (Fig. 8: 23–24) with incurved rims, both of which are entirely typical for assemblages of this type. Decoration is absent; however two vessels exhibit surface treatments in the form of external smoothing (Fig. 8: 22) and finger wiping resulting in an uneven, rippled surface (Fig. 8: 21). The latter is a common surface treatment among Late Bronze Age plain assemblages and can be paralleled locally by a vessel in a similar fabric from Lockington, Leicestershire (Woodward 2000, no. 15).

The inclusion of a substantially complete vessel (Fig. 8: 21) is notable and raises the possibility of structured deposition. Good evidence for this is known from a number of sites in the West Midlands, where deposition of ‘vessel sets’ including large jars of the type represented the vessel depicted in Fig. 8: 21 are interpreted as relating to feasting events (Woodward 1999). Absence in this instance of accompanying serving or drinking vessels reduces this as a possibility.

Thin sections of two samples of the pottery were examined by Alan Vince. Both contain coarse-grained sandstone fragments, identical to those found in the Millstone Grit. A small outcrop of Millstone Grit occurs to the north-west of Mountsorrel and it is possible that the pottery used a local boulder clay containing sandstone and quartz from that source.

### Anglo-Saxon

Pit 48023 cut the west side of pit 48020 (Fig. 9) A complete miniature vessel was retrieved from the sieved residue of a soil sample from the upper fill of this feature. It was initially thought to be of a similar date to the rest of the assemblage from

this part of the site and a charcoal sample from the same fill (48025), which gave a radiocarbon date of AD cal 430 to 610, was thought to be intrusive. However, parallels for the miniature vessel from early Anglo-Saxon sites have now been found, and the radiocarbon date probably gives an accurate date for the feature.

This unexpected finding naturally raised questions about the dating of the other features in the group. In particular, the pottery from pit 48020 was re-evaluated with several opinions being canvassed. This shows some similarities with the Anglo-Saxon material from Eye Kettleby and other similarly dated sites in the region (Nick Cooper, pers. comm.) but the assemblage seems to be generally consistent with a Late Bronze Age date (David Knight, pers. comm.). On balance, the Late Bronze Age or Early Iron Age date seems to be fairly secure although the possibility of an Anglo-Saxon provenance for pit 48020 cannot be entirely dismissed. It therefore seems most likely that the juxtaposition of the Anglo-Saxon feature 48023 with the earlier features in the group is purely accidental.

#### ANGLO-SAXON POTTERY: ED MCSLOY

A single, complete miniature vessel weighing 21g (Fig. 8: 25) was recovered from pit 48023 (fill 48025). Miniature 'thumb pots' are known from the Late Bronze Age (Gingell and Morris 2000, 152) although none are known which feature perforated lugs in the manner of this vessel. Although differing in detail a number of good parallels this miniature vessel are known to occur from Anglo-Saxon contexts, including Little Carlton, Nottinghamshire (Challis 1992, 123–4), Mucking, Essex (Hamerow 1993, fig. 125, no. 7; fig. 153, no. 3 and fig. 159, no. 2) and Eye Kettleby (Neil Finn, pers comm.).

#### Unphased Features

A very high proportion of the recorded features produced no dating evidence. Interventions through several of the amorphous and sinuous linear features in the northern part of the site (Fig. 10) showed that they had very clean fills and irregular profiles, suggesting that they may have been of natural origin. Nevertheless, the shapes in plan of some of these features suggest that they may have included the degraded remains of enclosure ditches.

Elsewhere, the spatial proximity, similarity of fills, and the lack of any later artefacts suggest that undated features may belong with one or other of the datable phases. The postholes that formed a tight grouping at the north-western end of the site are perhaps the most significant of these. This part of the site was covered by a dark subsoil layer, 48002, which sealed all of the postholes in this group, precluding the possibility that they were modern features.

There were considerable differences in the forms and in the fills of the postholes within the group, allowing a number of sub-groupings to be defined. Features 48209, 48226, 48185 and 48183 were all of similar dimensions, with steeply sloping sides and shallowly dished bases, and all had reddish brown silty fills (Fig. 11). Continuing to the south, four more postholes, 48218, 48220, 48178 and 48176, were slightly smaller and shallower but otherwise similar. Assuming



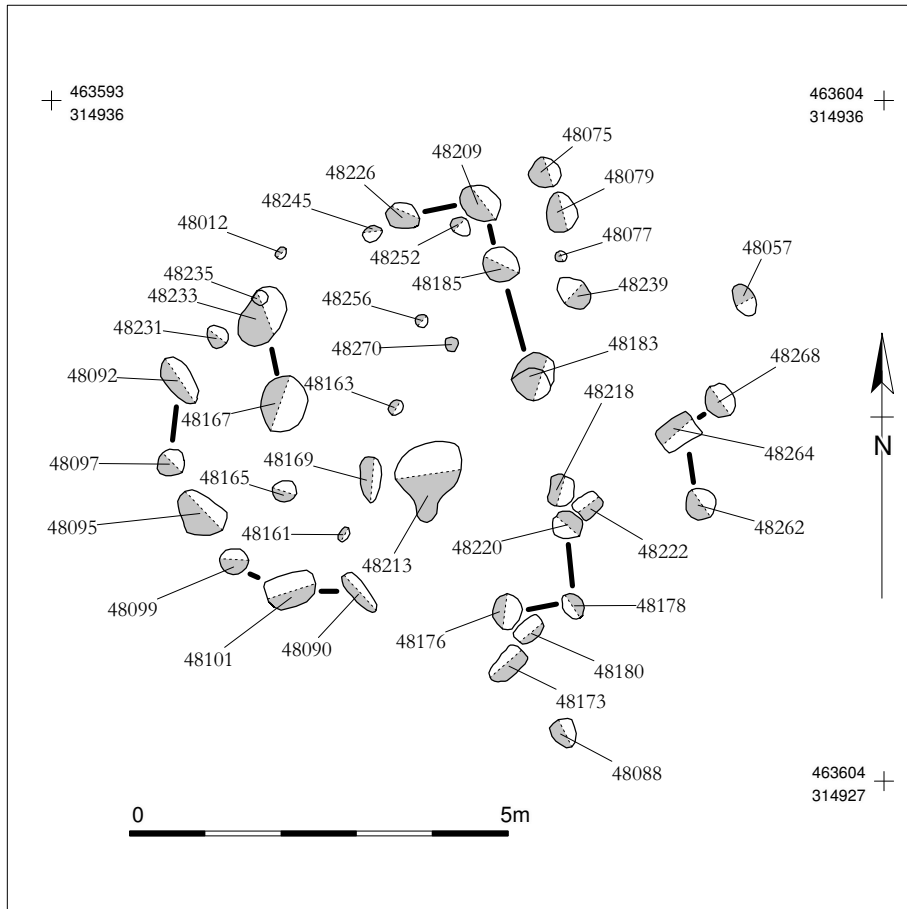

Fig. 10. Posthole group, showing possible associations.

the similar appearance implies that they were contemporary, these features together would represent a row of posts 5.4m long with a right-angled return to the west at either end. It is tempting to see this as the eastern side of a rectangular structure.

A western side could perhaps be partly supplied by postholes 48167 and 48233, the latter containing the possible remains of a post-pipe, 48235. These two features were larger and had greyer fills, but were of a similar depth and profile to the postholes making up the north-east corner of the putative structure. An arc of features could provide an alternative, bow-sided wall but, with the exception of posthole 48095, these were all of quite different appearance, being very shallow and irregular, with pale, yellowish silt fills.

Posthole 48079, which stood out as having a distinctive profile, with a sharply pointed base and clear evidence of a post-pipe, could have formed an alternative north-east corner to the structure, perhaps, along with posthole 48239, indicating

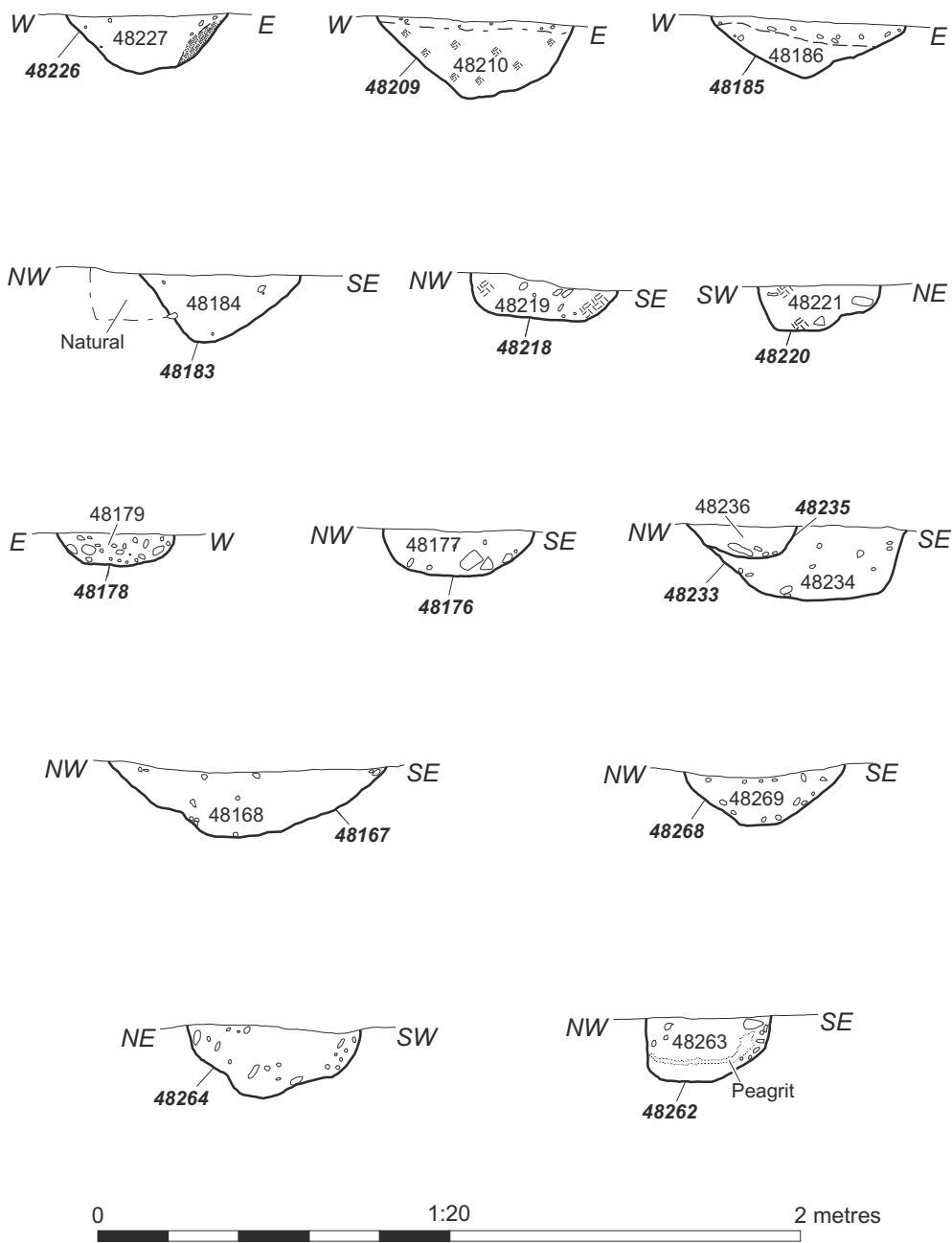

Fig. 11. Posthole group sections.

that the eastern side was realigned at some stage. Instances of groups of postholes in close proximity, 48173, 48176 and 48180, and 48218, 48222 and 48220, suggest that the structure was maintained and repaired over a period of time. A cluster of postholes on the eastern side, 48262, 48364 and 48268, had distinctive gravelly fills, and probably belong to a different phase of use.

This posthole group as a whole clearly included structural elements, and it is tempting to draw parallels with known Neolithic structures, such as those at Lismore Fields, Buxton, Derbyshire (Garton 1991, 12–13), but the interpretation of this group as a rectangular building is not entirely convincing. Other evidence for possible structures on site 10 was provided by matching pairs of some of the pit- or posthole-like features, such as features 48225 and 48244, and 48355 and 48353, which may represent simple two-post structures.

### Discussion, site 10

As pointed out in the research agenda for Leicestershire (Clay 1999), ‘Neolithic pottery has been elusive ... although recently it has been far more in evidence. Grooved Ware is known from Kirby Muxloe, Melton Mowbray, Syston, Thurmaston and Wanlip while Peterborough Ware has been found at Castle Donington, Enderby, Husbands Bosworth and Oakham’. Since the research agenda was written, other sites have been added, notably Rothley Lodge Farm (Cooper 2004, Clay *et al.* 2006) just over 4km west of site 10, and Rearsby Bypass Site 2 (Clarke 2007) barely 2km to the south-east. A high proportion of these sites have been found as a result of investigations on large development projects, and it is therefore not clear to what extent inferences can be made about the pattern of their distribution. However, there is a strong correlation between the locations of these sites and the river and stream valleys. The situation of site 10, where the land begins to rise from the flood plain of the Wreake, is very typical of the other known Neolithic pottery sites.

The pattern contrasts, to some extent, with the distribution of flint sites, which suggests that activity was more widespread and extended onto the higher land of the boulder clays (Beamish 2004). This could reflect a functional difference, the pottery being found on areas of settlement on the lighter alluvial and glacial soils of the valleys, with the flint distribution reflecting the more general exploitation of the wider landscape. Alternatively, the contrast could be a reflection of differential preservation, shallow features containing fragile prehistoric pottery only remaining where the site has been protected by alluvial or colluvial deposits, while the more robust flint survives in the topsoil after ploughing.

At least one typically Bronze Age piece was included within the flint assemblage from pit 48172. This is likely to have been intrusive, becoming incorporated into the fill of this shallow feature as a result of cultivation of the topsoil. Otherwise, most of the flint from the Neolithic features could be contemporary with the pottery. The quantity of debris from flint-working suggests that this activity was taking place at around the time that the pottery was deposited.

Other evidence for the activities occurring on the site is provided by the charred plant remains which, though generally sparse, indicate that the later stages of crop processing were taking place. Both flint-knapping and crop-processing, at a low level, would be typical of small scale domestic occupation.

The reason for the deposition of the Neolithic pottery in pits 48172 and 48188 is by no means obvious, especially as the upper parts of the vessels had been preferentially selected. It seems unlikely that this was purely related to the functional aspects of the site, and some kind of ritual significance may have attached to these features.

The re-utilisation of a Neolithic site in subsequent periods again seems to be typical. This could indicate that the location of site 10 was favoured, because of its relation to water sources or tractable land, and was repeatedly re-used, or it may imply that a small area first cleared of woodland in the Neolithic period remained open and available for agricultural use. The Middle Bronze Age was represented by a substantial ditch, an indication that the division and apportionment of land was beginning to take place at this time. The Late Bronze Age and Anglo-Saxon features in the central part of the site were shallow and poorly defined, and it is not possible to ascribe any particular function to any of them

#### SITE 11: BRONZE AGE AND IRON AGE ENCLOSURE DITCHES

##### **Ratcliffe on the Wreake parish, NGR 463013 314876**

The excavation area is on the ridge of relatively high ground between Ratcliffe on the Wreake village and the A46 Fosse Way (Fig. 2). The land falls away quite steeply to the road, 200m to the west, and to the south, where the spire of St Botolph's Church, 300m away, is a prominent local landmark.

Evaluation trenching, carried out following the results of the geophysical survey, located ditches and pits dated to the Middle Iron Age (NAL 2005) confirming that the very clear broad linear magnetic anomalies were archaeological in origin. As a result, the pipeline was re-routed to the south of its planned line to minimise the damage to the site. Additional evaluation trenches showed that the line still encroached upon large linear features in two areas, and this was confirmed when the working width was stripped of topsoil (Fig. 12).

##### **Middle Bronze Age: ditch 54000**

Ditch 54000 was relatively isolated 60m to the south-east of the other ditches on the site. It was a fairly substantial feature with a maximum width of 2m and depth of 0.75m (Fig. 13a). Its upper fills appeared to be the result of deliberate dumping and contained charcoal and fired clay in addition to pottery, animal bone and nine pieces of worked flint. By contrast, the lower fill was clean and silty, merging into the underlying natural clays. A high proportion of the animal bone consisted of

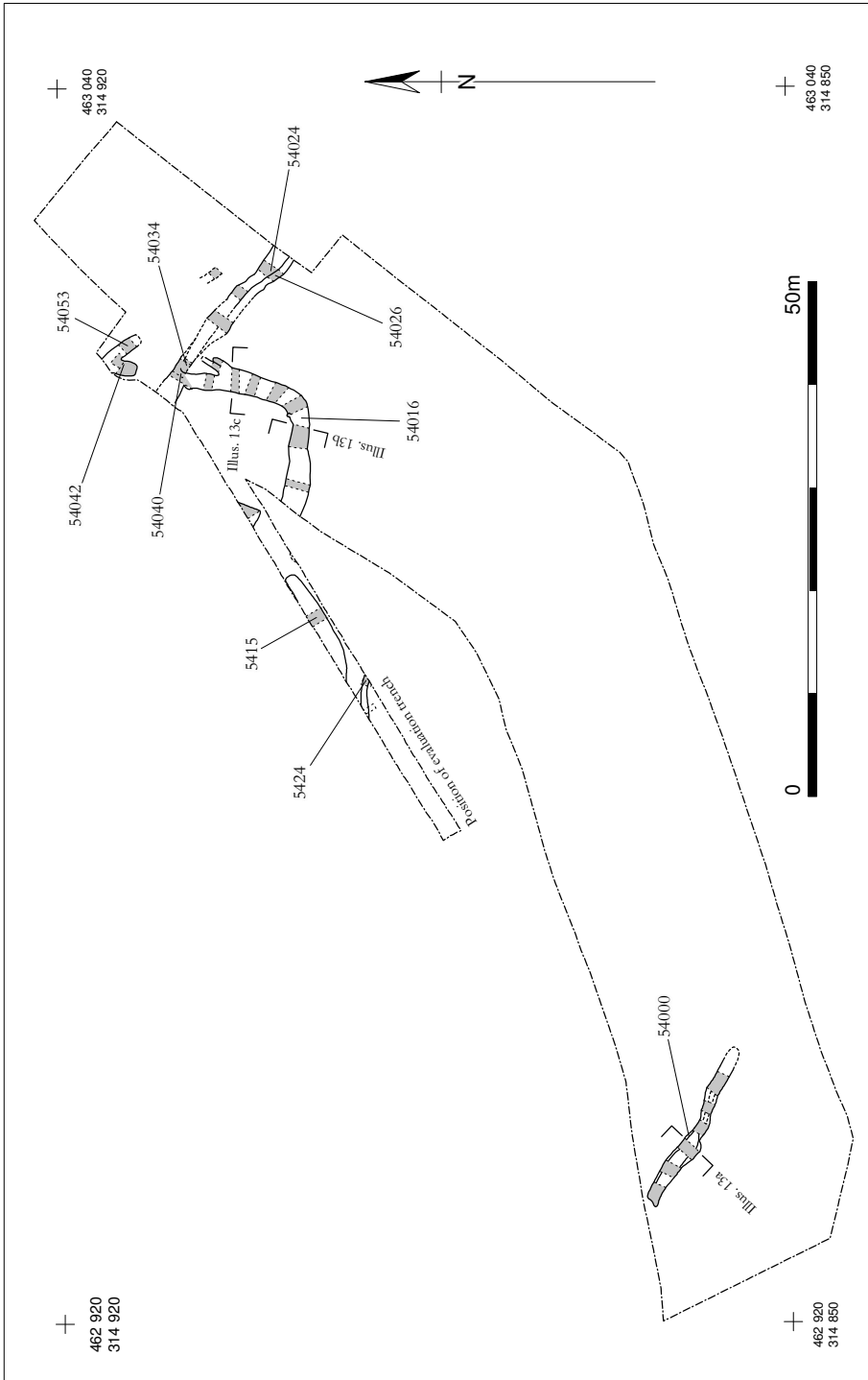

Fig. 12. Site 11, plan of all features.

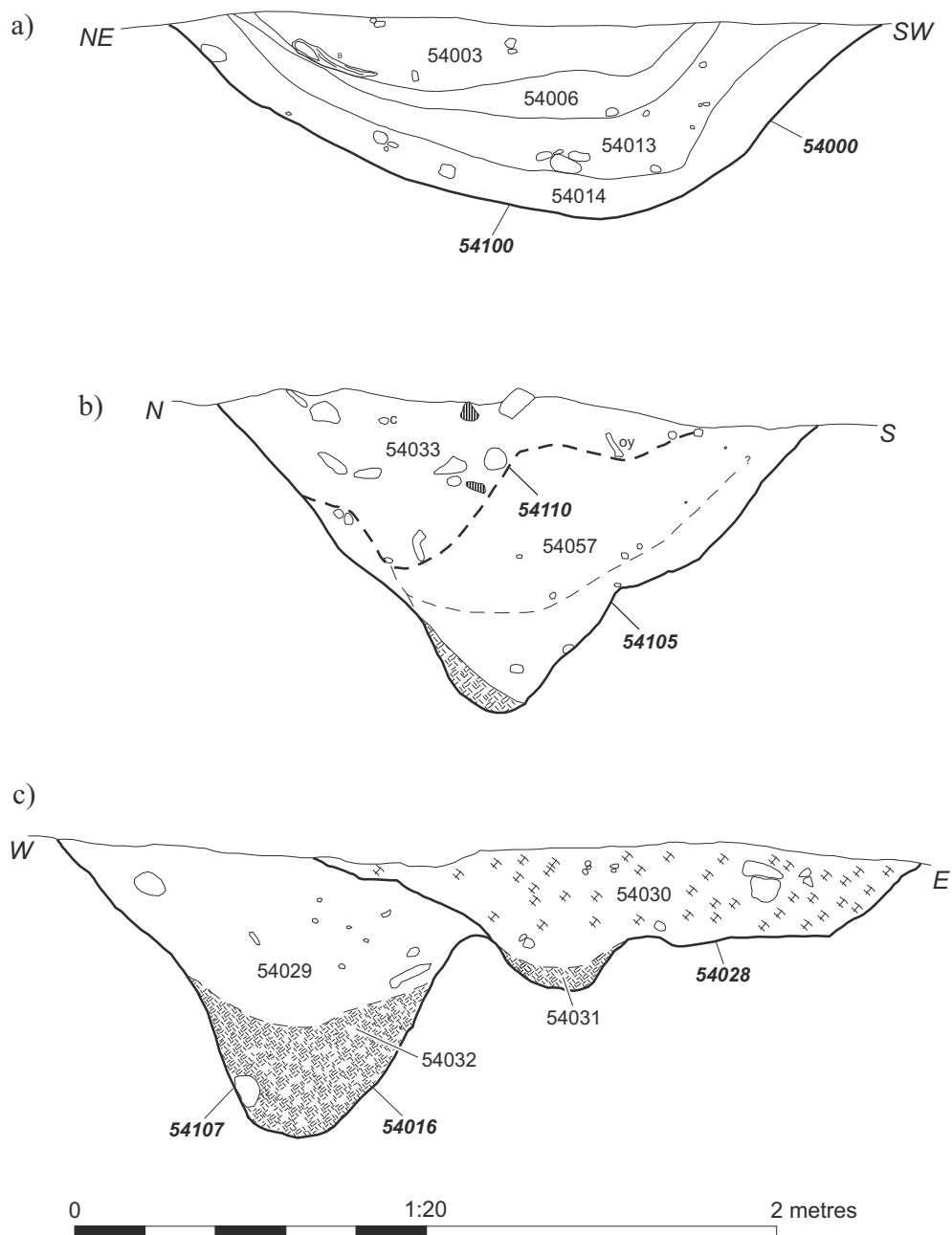

Fig. 13. Site 11 sections.

burnt fragments recovered from the sieved assemblage and probably represents hearth sweepings.

Radiocarbon dating of a piece of buckthorn charcoal gave a date of 1390 to 1120 cal BC. The pottery was consistent with this Middle Bronze Age date.

#### MIDDLE BRONZE AGE POTTERY, SITE 11: ED MCSLOY

Almost all material was retrieved from soil sample residues and is heavily fragmented, hindering identification. The level of fragmentation is reflected in a very low average sherd weight (0.9g). Featured sherds are restricted to plain or flattened rims possibly deriving from vessels of the bucket or barrel urn tradition (Fig. 8: 19). Coarse igneous fabric comparable to Middle Bronze Age sherds from site 10 is identifiable. A fragmentary fired clay object (Fig. 8: 20) in a hard, sandy fabric exhibits clear fingernail impressions. This object may be part of a cylindrical loomweight of Bronze Age form rather than a pottery vessel.

#### Iron Age: ditch 54016 and associated features

Ditch 54016 was the largest and most clearly defined of the group of ditches in the north-east part of the site. The excavated sections (Fig. 13b, c), especially the intervention near its corner, were relatively rich in finds, producing a large proportion of the Iron Age pottery from the site, as well as a fragment of saddle quern of uncertain date (Fig. 14: 26), animal bone, heat-affected clay and worked

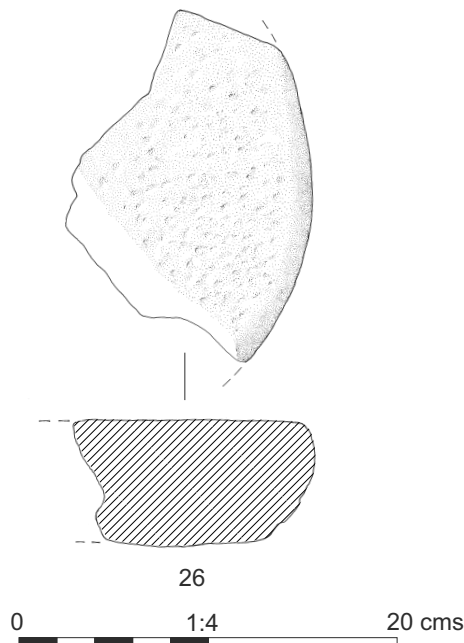

Fig. 14. Quern stone from context 54033.

flint. It appeared to be cut at its northern end by ditch 54040, although this relationship was not entirely clear. As these ditches together seemed to form the sides of a rectangular enclosure, visible in the geophysical survey results, it is likely that they were in contemporary use for at least part of their lifetimes. Ditch 54034 was a re-cut of ditch 54040 on a slightly displaced alignment. The fills of the original ditch and its re-cut both produced middle to late Iron Age pottery, the majority from the intervention near the southern edge-of-site baulk.

Ditch terminus 54042 was on the same alignment as ditch 54016, suggesting that these two features were contemporary. The small amount of pottery recovered from its fill was of a broadly similar date to that from 54016. Ditch 54053 appeared to cut ditch 54042; if this relationship is correct it would imply that the three sherds of late Bronze Age or early Iron Age pottery from this feature were residual.

Two features recorded in the evaluation trenching also formed elements of the group of geophysical anomalies. Finds from ditch 5415 included sherds from a Middle Iron Age scored bowl. Gully 5424 was a distinctive feature with a loose, stony fill and was interpreted as a possible construction cut for a wall footing. No finds were recovered from the among the stones but the surrounding fill contained pottery, including Iron Age Scored Ware, dated to the fourth century BC, a copper alloy pin from a brooch or buckle and a substantial amount of animal bone and antler, including a red deer skull with the antlers severed by sawing.

#### ANIMAL BONE, SITE 11: JENNIFER WOOD

Compared to the other sites on the pipeline route, the hand-collected animal bone, the bulk of it recovered from ditch 54016, was generally in a better state of preservation. The skeletal elements represent predominantly primary butchery waste, and twelve fragments, mostly cattle bones, had butchery marks consistent with disarticulation and jointing, with the meat-bearing bone removed for consumption elsewhere. A single sheep horn-core was chopped through the base, indicating horn removal for working. Seventeen fragments of bone displayed evidence of carnivore gnawing. This would suggest that the remains were left open to scavengers during, or as part of, the disposal process. The representation of skeletal elements is relatively uniform across the three largest animal bone assemblages recovered from this site, from ditches 54000, 54016 and 54042.

#### MIDDLE TO LATE IRON AGE POTTERY: ED MCSLOY

All the material dated to this period came from the group of linear features in the north-east part of the site. A large proportion of the pottery derived from a single intervention, 54023, through ditch 54016. In all, 713 sherds (115 recovered from soil samples) weighing 8334g (170g from samples) and representing at least 490 vessels (89 from samples) were recovered from site 11. This accounts for over 70% by weight of the Iron Age pottery from the pipeline as a whole.

The range of vessels and rim forms is typical for the Middle to Late Iron Age in the region (Knight 2002). Jars dominate, reflecting utilitarian function typical for Iron Age assemblages. Evidence for vessel use occurs as carbonised residues, most



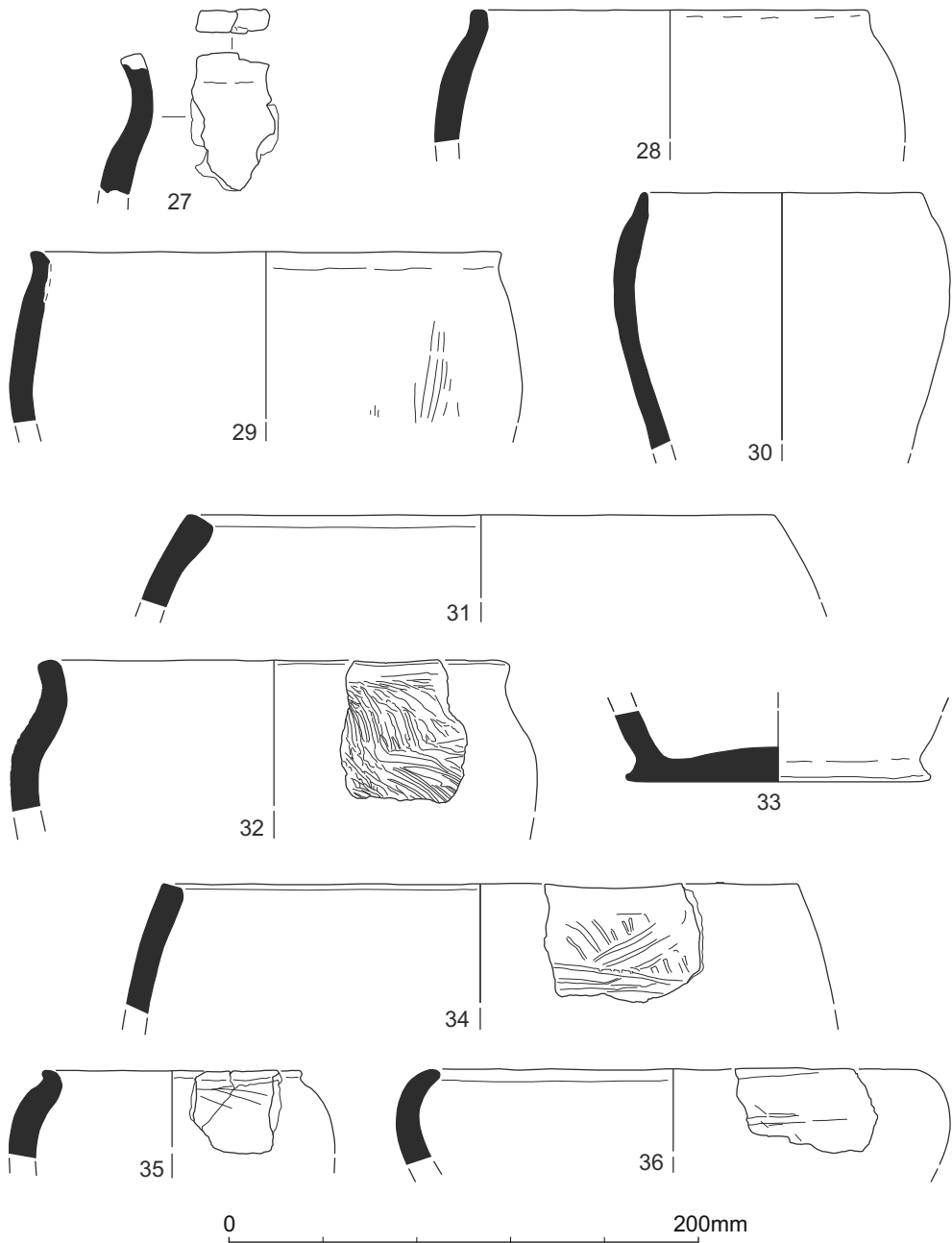

Fig. 15. Middle to Late Iron Age pottery.

---

27	Shouldered jar. Fingertip or tooled impressions to upper rim. Fill 54054 of ditch 54053.
28	Rounded jar with plain rim. Fill 54022 of ditch 54023.
29	Rounded jar with short, everted rim. Light, vertical scoring. Wear below rim interior possibly from lid. Fill 54022 of ditch 54023.
30	Rounded or ovoid jar with tapering rim. Fill 54022 of ditch 54023.
31	Neckless, probably barrel-shaped jar with squared rim. Fill 54022 of ditch 54023.
32	Shouldered jar with plain rim. Complex scored or combed decoration. Fill 54022 of ditch 54023.
33	Lower portion of probable jar with splayed base. Fill 54022 of ditch 54023.
34	Neckless, probably barrel-shaped jar with squared rim. Complex scored or combed decoration. Fill 54051 of ditch 54016.
35	Rounded jar with short, everted or bead-like rim. Light, oblique scoring below rim. Fill 54030 of hollow 54028.
36	Bowl or ovoid jar with incurving plain rim. Light horizontal scoring or wiping. Fill 54046 of ditch 54042.

---

Table 4. Illustrated Middle to Late Iron Age pottery.

likely arising from cooking over direct heat or within the embers of hearth or open fire.

Decoration, primarily scoring or combing, is a defining characteristic for Middle Iron Age assemblages from the area (Elsdon 1992) and was recorded on 8.4% of vessels from site 11, with no clear correlation with vessel form. Scoring may have served to roughen the surface of the vessel as an aid to handling, though this is less likely to be the primary intention behind the complex, multi-directional scoring or combing, which in some instances would seem to cover the surface of the vessel to the rim upper (Fig. 15: 32). Fingertip impressed decoration was noted on three vessels. Where, as here, this is restricted to the rim upper, fingertip decoration is not uncommon on Middle Iron Age assemblages from the region (Knight 2002). In common with larger Iron Age assemblages from the region, evidence for surface treatments such as burnishing or smoothing is minimal, here restricted to a single incidence of smoothing or wiping.

Of eleven samples of Iron Age pottery examined in thin-sections by Alan Vince, all but one are likely to be of local origin, within fifteen kilometres of the site. The exception probably originated at Haddon, south-west of Peterborough, though Harrold in Bedfordshire and Earith in Cambridgeshire are other possible sources. The local material divides into two groups: the sherds containing granitic rock fragments probably come from the Wanlip or Thurmaston area, while the other group could have been produced much nearer, perhaps even using boulder clays available on site. The Iron Age granite tempered fabrics are very similar to those from the Middle Bronze Age, suggesting that traditional methods and clay sources continued over a period of several centuries.

#### IRON AGE POTTERY, DISCUSSION: ED MCSLOY

The Iron Age pottery group from site 11, together with those more diagnostic elements from other sites from the pipeline route are considered to be of Middle

Iron Age date corresponding to Knight's 'Earlier La Tène' styles (Knight 2002, 136). Comparable assemblages are known locally from Kirby Muxloe, Leicestershire (Cooper 1994) and Wanlip, Leicestershire (Marsden 1998). Dating for the characteristic Scored Wares is conventionally seen as between the fourth to first centuries BC (Elsdon 1992). Scientific dating undertaken as part of analysis of the Wanlip assemblage suggests that the Scored Ware tradition may have been established in the locality as early as around 450 to 350 BC (Marsden 1998). There is some evidence to suggest that the elaborate multi-directional scoring of the type seen on some vessels from Site 11 (Fig. 15: 32 and 34), may be representative of a relatively late stylistic development, probably attributable to the second and first centuries BC. This would seem to be the case among large Scored Ware assemblages from Northamptonshire including Crick (Woodward and Hancocks forthcoming) where elaborate decoration was largely confined to later structures.

The range of fabrics and forms present is broadly comparable with material from published assemblages from the region (*ibid.*; Cooper 1994). Such assemblages are dominated by local fabrics, of which granitic types form a significant element. The small quantity of shell-tempered pottery is likely to have a non-local origin. This material provides evidence for movement of pottery, or more likely commodities, between communities at least 30 to 40km distant. Such evidence represents an interesting counterpoint to evidence for transit of granitic pottery attested at sites outside the region (Knight *et al.* 2003).

#### SITE 11 FLINT: LYNNE BEVAN

The site produced 46 items, together weighing 261g. A microlith fragment and three other retouched items were identified in the assemblage and the remaining 40 items consisted of flakes and chunks, the largest of which was half of a large split pebble. Such rough split pebbles and chunks are typical of the 'smash and grab' technology of later Bronze Age industries in which flint nodules were smashed up, rather than being systematically reduced as cores, in order to produce flakes which could be used and then discarded (Bevan, forthcoming). The general appearance of the other debitage also supports a Later Bronze Age to Iron Age date for the assemblage, since flakes were small and squat (e.g. Pitts 1978), their size and shape determined by the fairly small size of the pebbles used and by unskilled knapping techniques, without formal platform preparation.

However, two of the four retouched items from the site, both from context 54015, are much earlier in date. One is a slender, retouched, backed blade (Fig. 16: 37), a form of microlith type dating to the Late Mesolithic period, and the other is a retouched core rejuvenation flake from a blade core which probably also dates to the Late Mesolithic period (Fig. 16: 38). They are both of the same dark brown translucent flint and they may even have come from the same core.

The other two retouched items were both notched pieces, one of which was a complex composite tool (Fig. 16: 39), a retouched, notched blade which had been worked around all of its edges, with some denticulation along one side and some further retouch on the reverse. Composite tools or 'combination tools', which first

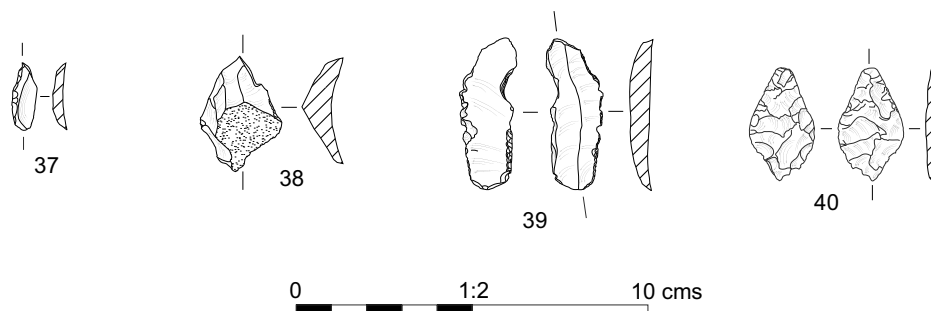

Fig. 16. Flint from sites 11 and 12.

37	Backed blade, broken at both ends, with retouch along one slightly curved side. Dark brown translucent flint. Late Mesolithic. Fill 54015 of ditch 54000.
38	Retouched core rejuvenation flake from a blade core. Dark brown translucent flint. Probably Late Mesolithic. Fill 54015 of ditch 54000.
39	Composite tool, a retouched, notched blade worked and utilised at every edge. Medium brown, formerly translucent flint, now with partial white recortication. Probably Later Neolithic. Fill 54019 of ditch 54016.
40	Leaf-shaped arrowhead, with fine flaking on each side and slight damage to both ends. Style conforms to the ogival Type 3A in Green's typology (Green 1980, fig. 28:K, 71). Light brown translucent flint. Early Neolithic. Fill 65005 of pit 65004.

Table 5. Illustrated flint from sites 11 (nos. 37–39) and 12 (no. 40).

appeared during the Neolithic period and continued in use into the Early Bronze Age, 'are most common in the Later Neolithic assemblages' (Butler 2005, 168). The notch on one side, denticulation of the other, as well as the subsequent retouching on the reverse of the piece and the fact that much of this edge-modification took place after partial recortication had occurred, indicates that this was a multi-purpose tool possibly discarded, subsequently recovered and further modified and re-used.

The other notched tool is far less elaborate and was made on a large flake which terminates in a hinge fracture. A pronounced bulb of percussion indicates a hard hammer technique. Although this tool may date to the Late Neolithic period, a much later date is more probable, since 'notched pieces normally manufactured on stubby, hammer-struck flakes or fragments' were made during the Later Bronze Age period (Butler 2005, 185–7, figs. 76: 6–7), and may well have continued into the Iron Age.

### Discussion: site 11

The site appears to have consisted of a system of enclosures defined by ditches. The pottery and the radiocarbon determination point to a wide spread of dates

spanning perhaps as much as a thousand years from the Middle Bronze Age to the Iron Age. The occurrence of Mesolithic and probable Neolithic flint within the ditch 54000 demonstrates that surface material was incorporated into the upper fills of this ditch, but the pottery in this feature is unlikely to have been residual, given the quantities recovered. This would leave two possibilities. Ditch 54000 may have been unrelated to the other features. The situation of the site, on top of a ridge commanding wide views to the south and east, would have made it a favoured area for occupation, and it is quite possible that the ditches of a field system established in the Iron Age could have impinged on an earlier Bronze Age system.

Alternatively, these ditches may have originally been part of a single ditch system, first established in the Bronze Age, ditch 54016 and its related features being kept open long after ditch 54000 fell out of use. This seems less likely although, once established, field systems are likely to be relatively stable features in the landscape.

The function of the site seems to have been largely agricultural, the areas enclosed by the ditches being small, typical of an infield pattern close to a focus of settlement. Small scale primary butchery and processing of horn and antler would be consistent with this kind of location. The later components of the flint assemblage seem to be of Late Bronze Age or even Iron Age date, contemporary with the features from which they were recovered, and would also be consistent with small scale activity on the periphery of an area of domestic occupation.

In addition to showing that the linear features extend beyond the limits of the excavation area, the geophysical survey results demonstrated that the local soils are magnetically responsive. This would provide a non-intrusive way to determine the limits of this area of activity in the future.

## SITE 12, POSSIBLE BRONZE AGE ROUNDHOUSE, COSSINGTON PARISH, NGR 461940 314130

### Introduction

This site was on a spur of high ground, with wide views of the surrounding area to the south and west. It consisted of three elements: a ring gully 9m in diameter, a tight cluster of postholes and stake-holes, and two discrete pits (Fig. 17).

A copper alloy tanged knife, just possibly of Bronze Age date (Fig. 20: 41), was recovered from the field to the south of the site by pre-construction metal detecting, and eight pieces of worked flint were found in this field and the field to the north during fieldwalking. Apart from these widely scattered surface finds, there were no specific indications of the presence of the site and the area was not targeted for trench evaluation, the ring gully being identified only during topsoil stripping. The topsoil was a mid- to light brown silty clay and overlay yellowish brown natural sandy clay, with occasional patches of orange sand and gravel.

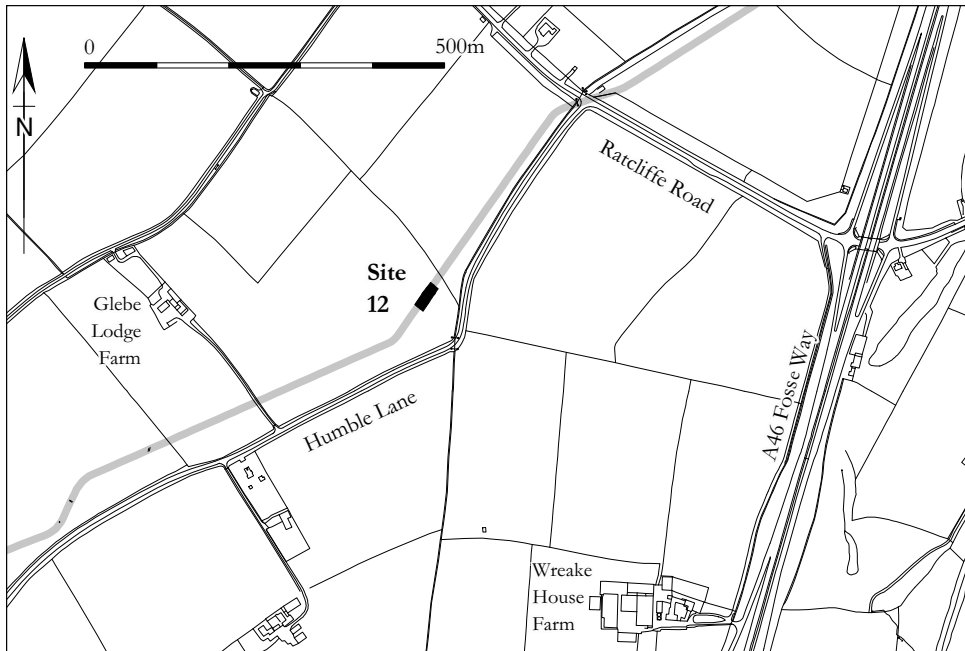

Fig. 17. Location of Site 12.

(Mapping reproduced by permission of Ordnance Survey on behalf of HMSO.  
© Crown copyright 2008. All rights reserved. Ordnance Survey Licence number  
100021059.)

### Site Description

The ring gully was made up of three curvilinear arcs, two of which were overlapping, leaving two gaps, one to the north-west 4.5m wide, and a smaller one to the east 2.8m wide (Fig. 18). The south-western segment, 65070, was poorly preserved with a maximum depth of only 0.07m (Fig. 19b). At its southern end it appeared to be cut by the southern arc, 65069 (Fig. 19c). Overall, the northern arc, 65068, was the most substantial segment (Fig. 19a), surviving to a depth of 0.2m for most of its length. A single small sherd of Roman pottery was recovered from intervention 65018 through segment 65069.

In all, 313 sherds of pottery were recovered from the ring gully, including material recovered from bulk samples. These were concentrated in the parts of the gully either side of the east-facing gap. The archaeo-botanical remains recovered from the sieved bulk soil samples showed a similar distribution.

The fifteen small postholes or stake-holes clustered within a roughly circular area 3m across were largely undated. A single small sherd of undiagnostic pottery was recovered from one of these features, 65054, while stake-hole 65047 produced one piece of worked flint. A more significant flint piece was recovered from the shallow, isolated round pit, 65004, at the northern end of the site (Fig.

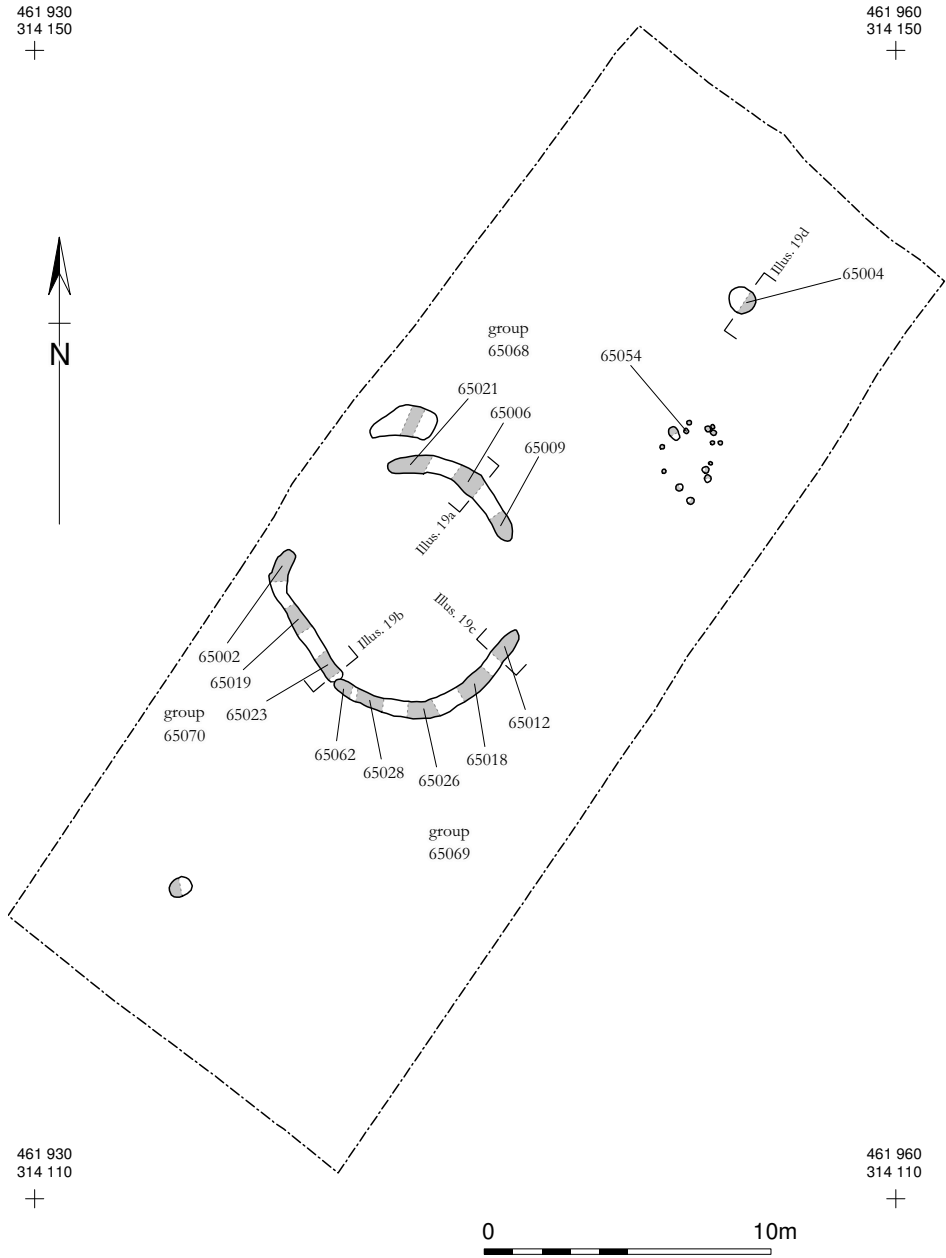

Fig. 18. Site 12, plan of all features.

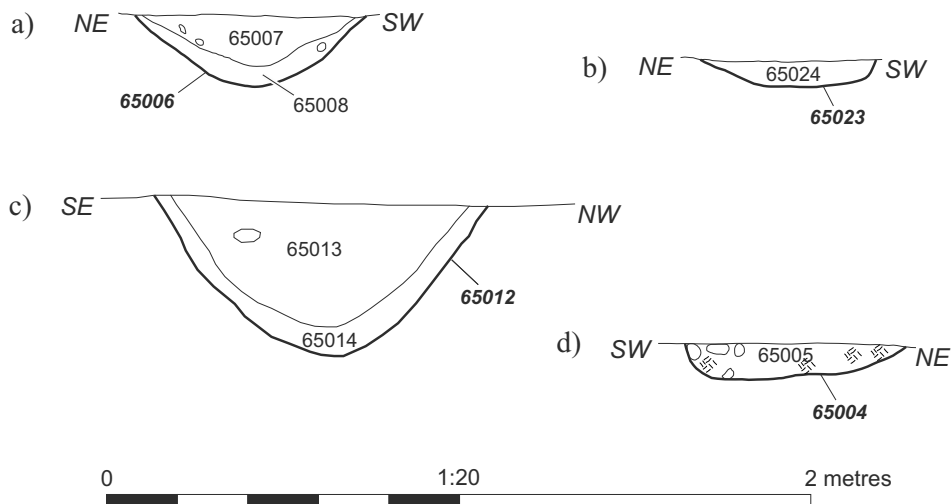

Fig. 19. Site 12 sections.

19d). This was a leaf-shaped Neolithic arrowhead. This is thought to be residual, as other flints from the feature, though not particularly diagnostic, are more typical of a later date, and may be contemporary with the prehistoric pottery recovered from the site.

#### POTTERY: ED MCSLOY AND RUTH LEARY

Ring gully 65017 yielded a body sherd with a single horizontal groove, most likely from a common everted-rim jar form. The fabric, body form and surface treatment suggest a date in the late first to early second century.

The rest of the recovered material from the ring gully is typically heavily fragmented and includes few featured sherds. Fabrics are a mix of granitic and sandy types, which are broadly similar to more certainly Middle Bronze Age groups from Sites 10 and 11. Sherds in coarse igneous rock-tempered fabric are thick-walled, in the range 11 to 13mm, and probably derive from bucket urn-like vessels.

#### FLINT: LYNNE BEVAN

The assemblage from Site 12, although small, comprising 36 items weighing 329g, was of particular interest as it included a leaf-shaped arrowhead of Neolithic date (Fig. 16: 40). Other chronologically diagnostic flints include a fragment from a blade/flake core, a blade core fragment, a retouched, exhausted blade core and an ovoid side and end scraper. These are probably all of Late Neolithic to Early Bronze Age date. Although not particularly diagnostic, the remainder of the flints from Site 12, including two large flake core fragments made from roughly-flaked



Fill	Intervention	weight/g	%
65022	65021	2	0.37
65008	65006	91	16.64
65011	65009	140	25.59
65013	65012	252	46.07
65017	65018	17	3.11
65027	65026	33	6.03
65063	62062	7	1.28
65003	65002	5	0.91
<b>Total</b>	<b>547</b>	<b>100.00</b>	

Table 6. distribution of pottery by weight in site 12 ring gully.

poor quality pebbles and a number of broad struck chunks and flakes, could be contemporary with prehistoric pottery recovered from the site.

### Discussion, site 12

The ring gully is likely to have enclosed a roundhouse-type structure, the accumulation of finds suggesting that it was an eaves-drip gully rather than the dug-in base of a wattle wall. The spatial distribution of both the pottery and archaeo-botanical remains shows a very strong bias towards the east facing gap, but was not confined to the terminals of the gully. This pattern would be expected if the pottery derived from the disposal of domestic debris concentrated on an area activity around the gap, which presumably corresponds to the entranceway of the structure.

The sherd of Roman pottery is likely to have been intrusive, as the other diagnostic finds all suggest a prehistoric date for the ring gully. The more specific Middle Bronze Age date is far from secure, as it is based on the general similarity of the pottery to that from the better dated assemblages on sites 10 and 11, but if it is correct then this would be an early example of a roundhouse, settlement evidence from this period being notably rare in the region (Clay 2006, 82). No comparable examples are known from Leicestershire, although the 5.34m diameter post-built roundhouse at Ridlington in Rutland (Beamish 2005) was only 25km away. To the south and west of the site, there is evidence of extensive Bronze Age activity, the barrow cemetery at Cossington (Thomas 2007), less than 2km to the west, being a notable example.

It seems probable that the group of stake-holes and the two pits recorded on site 12 were broadly contemporary with the ring gully but the absence of datable material from features and the lack of stratigraphic relationships means that this is by no means certain.

The features on the site were cut into a layer of colluvium. This may have resulted from hillwash from newly ploughed land; if so it would imply that the area had been brought into cultivation before the site was occupied.

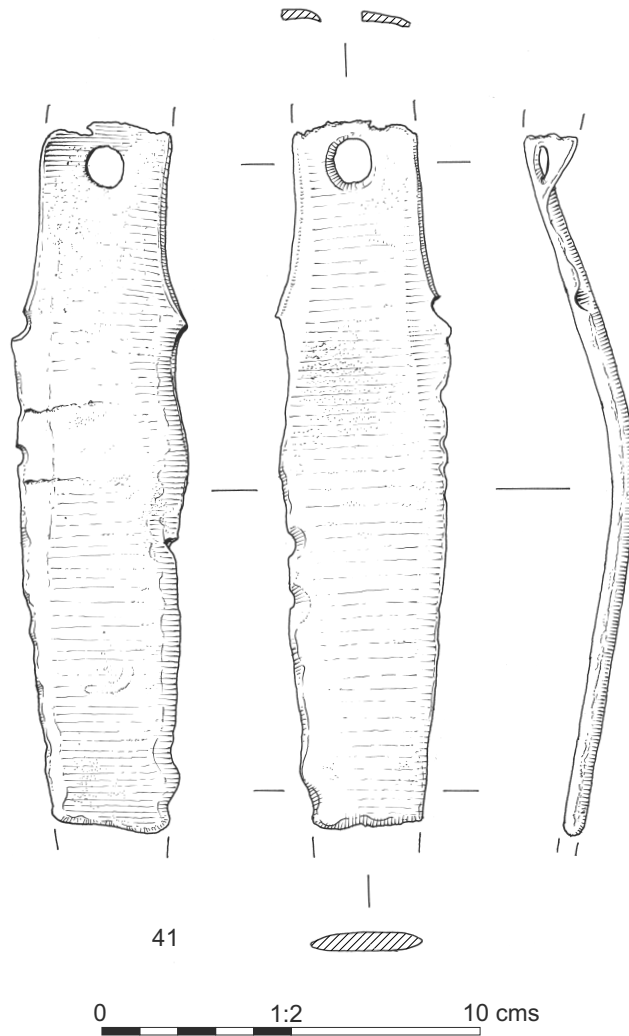

Fig. 20. Copper alloy tanged knife blade.

## CONCLUSIONS

These three prehistoric sites located and characterised during the course of the construction of the pipeline add significantly to an appreciation of the patterns of early activity in the region. The earliest phase of activity on site 10, in particular, makes a significant contribution to understanding the pattern of settlement of the land during the Neolithic period and adds to an increasingly complex picture of activity along the river valleys to the north of Leicester at this time. The later phases on site 10, and the other two sites, provide evidence for the subsequent development of settlement and the establishment of land division.

More generally, the project has confirmed the high archaeological potential of the area to the north of Leicester. Because of the need to avoid present day settlement and the possibilities of re-routing during pre-construction planning, the numbers of areas of archaeological significance crossed by pipelines almost certainly underestimate their density in the wider landscape. The land stripped of topsoil along the pipeline route provided a sample of just under 40 hectares in total area and there is no reason to think that the density of archaeological remains in the countryside beyond the limits of the pipeline easement is any less than that found during the evaluations, excavations and watching brief.

The engineering constraints on linear infrastructure developments such as gas and water pipelines and electricity cables mean that they are often laid closely parallel to existing pipelines. There is therefore a strong possibility that the areas alongside some of the sites investigated will be subject to development proposals in the future. The results from the investigations reported here will allow fully informed decisions to be made about appropriate mitigation measures on any such proposals.

## ARCHIVE

The site archive has been deposited with Leicestershire Museums Services along with the retained finds, subject to the agreement of landowners. Copies of the assessment report, and all the specialist reports commissioned during the course of this project are available online through the ADS website.

## REFERENCES

- Allen, C. S. M., Harman, M. and Wheeler, H., 1987 'Bronze Age Cremation Cemeteries in the East Midlands', *Proc. Prehist. Soc.* 53, 187–221.
- Bamford, H. M., 1975 'The Pottery', in Moore, W. R. G. and Williams, J. H. 1975 'A later Neolithic site at Ecton, Northampton', *Northamptonshire Archaeol.* 10, 12–19.
- Barrett, J., 1980 'The pottery of the later Bronze Age in lowland England', *Proc. Prehist. Soc.* 46, 297–320.
- Beamish, M., 2004 'The first farming communities', in Bowman, P. and Liddle, P. (eds) *Leicestershire Landscapes, Leicestershire Museums Archaeological Fieldwork Group monograph 1*, 30–39.
- Beamish, M., 2005 'Bronze Age settlement at Ridlington, Rutland', *TLAHS* 79, 1–26.
- Bevan, L., forthcoming *A Late Bronze Age Flint Assemblage from the Riverside Zone at Runnymede Bridge, Egham, Surrey*. To be included in a British Museum monograph.
- BGS, 1974 Geological Survey of Great Britain, 1:50 000 series, sheet 156 Leicester, British Geological Survey.
- Butler, C., 2005 *Prehistoric Flintwork*. Stroud: Tempus.

- Challis, K., 1992 'An Early Anglo-Saxon Pottery Vessel from Little Carlton', *Trans. Thoroton Society of Nottinghamshire* 96, 123–4
- Clarke, S., 2007 A607 Rearsby Bypass Leicestershire excavation report, unpublished client report for Leicestershire County Council, ULAS report no. 2007–057.
- Clay, P., 1999 'The Neolithic and Bronze Age of Leicestershire and Rutland', *TLAHS* 73, 1–18.
- Clay, P., 2001 'Leicestershire and Rutland in the First Millenium BC', *TLAHS* 75, 1–19.
- Clay, P., 2006 'The Neolithic and Early to Middle Bronze Age' in Cooper, N. J. (ed.) *The archaeology of the East Midlands*, Leicester Archaeology Monograph 13.
- Clay, P., Hunt, L. and Cooper, L., 2006 *Rothley Lodge Farm, Leicester Road, Rothley, Leicestershire (SK 592 140). Assessment Report and Updated Project Design*. Unpublished report for University of Leicester Archaeological Services.
- Cooper, L. P., 1994 'Kirby Muxloe, A46 Leicester western bypass', *TLAHS* 68, 162–5.
- Cooper, N. J., 2004 'The pottery', within Hunt, L. 2004 *An Archaeological Field Evaluation at Rothley Lodge Farm, Leicester Road, Rothley, Leicestershire*. Unpublished report for University of Leicester Archaeological Services.
- Elsdon, S. M., 1992 'East Midlands Scored Ware', *TLAHS* 66, 83–91.
- Garton, D., 1991 'Neolithic settlement in the Peak District: perspective and prospects', in Hodges, R. and Smith, K. (eds.) *Recent developments in the archaeology of the Peak District*, Sheffield Archaeological Monographs 2.
- Gibson, A. M., 1998 'Neolithic Pottery', in Clay, P. 1998 'Neolithic/Early Bronze Age pit circles and their environs at Oakham, Rutland', *Proc. Prehist. Soc.* 64, 318–21.
- Gibson, A. M. and Kinnes, L. A., 1997 'On the urns of a dilemma: radiocarbon and the Peterborough problem', *Oxford J. Archaeol.* 16(1), 65–72.
- Gibson, A. M. and Woods, A., 1997 *Prehistoric Pottery for the Archaeologist* (2nd edition) Leicester, Leicester University Press.
- Gingell, C. J. and Morris, E. L., 2000 'Form Series', in Lawson, A.L. 2000 *Potterne 1982–5: Animal Husbandry in Later Prehistoric Wiltshire* Salisbury, Trust for Wessex Archaeology, 149–57
- Hamerow, H., 1993 *Excavations at Mucking Volume 2. The Anglo-Saxon Settlement: Excavations by M. U. Jones and W. T. Jones*, English Heritage Archaeological Report 2, London, English Heritage with British Museum Press
- Hains, B. A. and Horton, A., 1969 *British Regional Geology: Central England*, HMSO, London.
- Knight, D., 2002 'A regional ceramic sequence: Pottery of the First Millenium BC between the Humber and the Nene', in Woodward, A. and Hill, J. D. (eds) *Prehistoric Britain: The Ceramic Basis*. Oxford, *Prehistoric Ceramics Research Group Occasional Paper 3*, Oxbow Books, 119–42.

- Knight D., Marsden, P. and Carney, J., 2003 'Local or Non-Local? Prehistoric Granodiorite Tempered Pottery in the East Midlands', in Gibson, A. M. (ed) *Prehistoric Pottery, People, Pattern and Purpose*, B.A.R. int. ser. 1156, Oxford, 111–125.
- Liddle, P., 1982 *Neolithic and Earlier Bronze Age Leicestershire* Leicester Museum Archaeological Report 4.
- Marsden, P., 1998 'The Prehistoric pottery', in Beamish, M. 1998 'A Middle Iron Age site at Wanlip, Leicestershire', *TLAHS* 72, 1–91.
- NAL, 2004a *Ashby Folville to Thurcaston proposed pipeline: archaeological desk based assessment*. Network Archaeology Limited client report no. 318.
- NAL, 2004b *Proposed Ashby Folville to Thurcaston 450mm dia. Gas Pipeline: archaeological field survey report*. Network Archaeology Limited client report no. 502.
- NAL, 2005 *Ashby Folville to Thurcaston gas pipeline: archaeological evaluations December 2004 and February 2005*, Network Archaeology Limited client reports nos. 503 and 513.
- NAL, 2006 *Ashby Folville to Thurcaston, natural gas pipeline: Archaeological excavations and watching brief, post-excavation assessment of potential for analysis and updated project design*. Network Archaeology Limited client report no. 517.
- Pitts, M., 1978 'On the Shape of Waste Flakes as an Index of Technological Change in Lithic Industries', *Journal of Archaeological Science* 5, 17–37.
- Thomas, J., 1999 *Understanding the Neolithic* London, Routledge.
- Thomas, J., 2007 'Three Bronze Age barrows at Cossington: a history of use and re-use', *TLAHS* 81, 35–63.
- Woodward, A., 1999 'When did pots become domestic? Special pots and everyday pots in British prehistory', *Medieval Ceramics* 22–23, 3–10.
- Woodward, A., 2000 'The Prehistoric pottery', in Hughes, G. 2000 *An Early Bronze Age Cemetery at Lockington, Leicestershire* Oxford, Oxbow Books, 48–61.
- Woodward, A. and Hancocks, A., forthcoming 'The Prehistoric Pottery', in Hughes, G. and Jones, L. forthcoming *Excavations at Crick Covert Farm*, Northamptonshire.

## ACKNOWLEDGEMENTS

The work described here was commissioned by Murphy Pipelines Ltd on behalf of National Grid; thanks, among others, to Chris Rixon, Russell Harris, John Murphy, Joe Lynch, Pat O'Sullivan, and Guy Handley of MPL and Peter Nuttall, Nick Travis, Howard Radcliffe and John Davies of NG. We would especially like to thank Linda Bonnor of Groundwork Archaeology who monitored the work on behalf of National Grid.

We should also like to thank Richard Clark, Peter Liddle, and Helen Wells of Leicestershire County Council, Chris Wardle of Leicester City Council, Jim

Williams of English Heritage, Neil Finn, Sophie Clarke, Nick Cooper, John Thomas and Matt Beamish of ULAS and David Knight of TPAC. Particular thanks to Neil Finn for alerting us to the Anglo-Saxon parallels to the miniature vessel from site 10. Specialist contributors were: Ed McSloy and Annette Hancocks, Ruth Leary, Margaret Ward, Alan Vince, Lynne Bevan, Hilary Major, Rose Nicholson, Malin Holst, Jen Wood (née Kitch), Jane Cowgill, Maisie Taylor, James Rackham, Gemma Martin and John Giorgi, Rowena Gale, Paul Buckland, Cath Langdon and Rob Scaife, Wendy Booth, Peter Northover, and Tomasz Goslar and staff of Poznań Radiocarbon Laboratory.

For Network Archaeology Ltd, the project was managed by Claire Lingard. Mark Ward coordinated the fieldwork and carried out the initial post-excavation work aided by Matt Hobson. Fieldwork staff were: Gerry Martin, Gareth Davies, Ian Price, Martin Campbell, John Foulkes, Bob Hamilton, Keith Hinton, Pat Kent, George Luke, Debora Moretti, Stuart Noon, Ken Owen, Richard Simms and Kerry Tyler, with metal detecting by: Barry Wright, Lee Hooke, Colin Parker, Andy Chamberlain, Brian Biddles, Lee Walkley, Andy Tansley, David Dean and Nigel Porter. Rachel Savage (née Gardner) and Patrick Daniel assisted with research and Nash Gaddas with checking and cross-referencing text. The text of this article has drawn freely on the desk-based assessment, written by Rosey Burton, site narratives prepared by Mark Ward, and the assessment report by Claire Angus.

RICHARD MOORE, BSc, PhD, MIFA, has worked in archaeology for over twenty years, the last eleven of which with Network Archaeology Ltd. During that time, the archaeology of pipelines has taken him to Germany and Azerbaijan, as well as many parts of the UK.

Network Archaeology Ltd, the country's leading specialist in the archaeology of linear construction projects, is based at 28 West Parade, Lincoln, LN1 1JT.