

ASHBY FOLVILLE TO THURCASTON: THE ARCHAEOLOGY OF A LEICESTERSHIRE PIPELINE PART 2: IRON AGE AND ROMAN SITES

Richard Moore

with specialist contributions from:

*Ruth Leary, Margaret Ward, Alan Vince, James Rackham, Maisie Taylor,
Jennifer Wood, Rose Nicholson, Hilary Major and Peter Northover*

illustrations by:

Dave Watt and Julian Sleap

Neolithic, Bronze Age, Iron Age, Roman and early Anglo-Saxon remains were excavated and recorded during construction of the Ashby Folville to Thurcaston gas pipeline. The earlier prehistoric sites were described in the first part of this article; this part covers three sites with Roman remains, two of which also had evidence of Iron Age activity. These two sites, between Gaddesby and Queniborough, both had linear features and pits; the more westerly of the two also had evidence of a trackway and a single inhumation burial. The third site, between Rearsby and East Goscote, was particularly notable as it contained a 7m-deep stone-lined Roman well, which was fully excavated.

INTRODUCTION

Network Archaeology Limited carried out a staged programme of archaeological fieldwork between autumn 2004 and summer 2005 on the route of a new natural gas pipeline, constructed by Murphy Pipelines Ltd for National Grid. The 18-inch (450mm) diameter pipe connects above-ground installations at Ashby Folville (NGR 470311 312257) and Thurcaston (NGR 457917 310535).

The topography and geology of the area and a description of the work undertaken were outlined in part 1 of this article (Moore 2008), which covered three sites with largely prehistoric remains, sites 10, 11 and 12. Of the later Iron Age and Roman sites, described here, sites 4 and 5 were 800m apart on the edge of the flood plain of Gaddesby Brook, roughly equidistant from Gaddesby and Queniborough villages. Site 9 was between Rearsby and East Goscote, just to the east of the Leicester to Peterborough railway line.

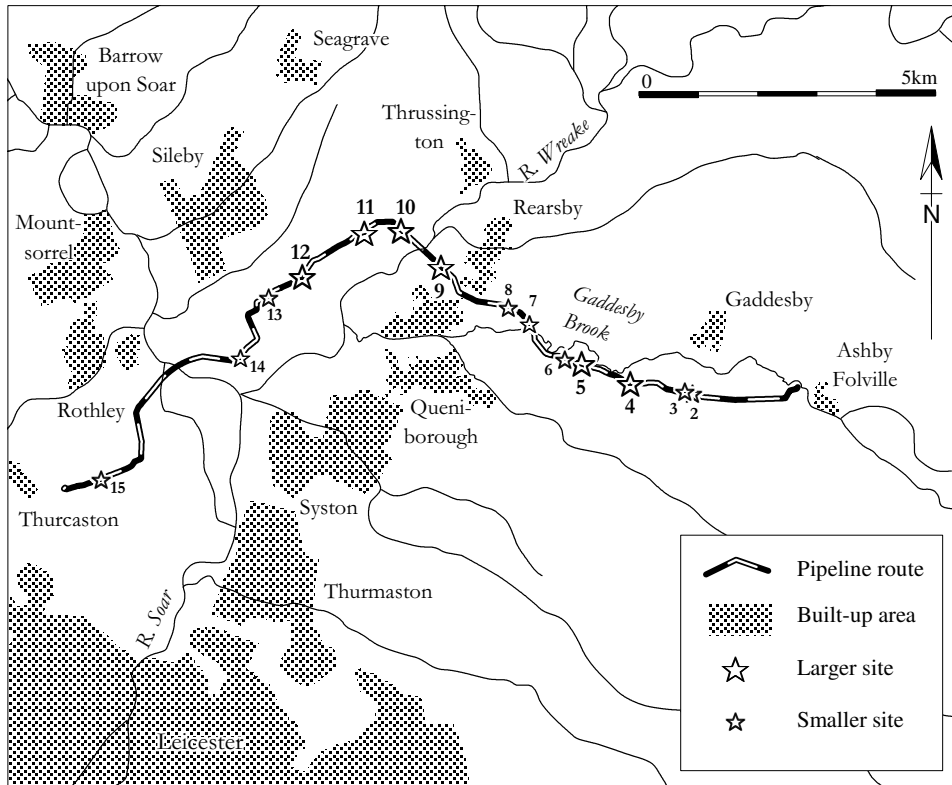

Fig. 1. Location of the pipeline showing archaeological sites.

Several of the smaller sites investigated on the pipeline route also had evidence of Iron Age or Roman activity. Sherds of two pottery vessels, probably of middle to late Iron Age date, were recovered from the fill of a ditch during evaluation trenching at site 2 (Gaddesby Parish, NGR 468560 312145), but full excavation failed to provide any further dating evidence from this site, a grouping of small linear features and irregular pits. A single sherd of Iron Age pottery was recovered from one of three linear features at site 3 (Gaddesby Parish, NGR 468395 312190). Two severely truncated linear features at site 6 (Queniborough Parish, NGR 466380 312740) produced rather more pottery: 35 sherds dating from the middle Iron Age to early Roman period. Details of these sites are given in the evaluation and assessment reports (NAL 2005, 2006) available in the site archive (Leicestershire Museum Services, accession number X.A185.2004) or through the Archaeology Data Service (ADS).

SITE 4: IRON AGE AND ROMAN FEATURES

Gaddesby Parish, NGR 467490 312320

Introduction

This site was identified by geophysical survey and confirmed by evaluation trenching. It consisted mostly of linear features, ranging in size from small gullies to quite substantial ditches, along with a few pits. A single small ring gully may have been evidence of settlement-related structural remains, but the significance of the site rests mainly with the comparatively rich artefact assemblages.

Deposits of glacial sand and gravel underlay the site, with boulder clay beneath the gently rising ground to the east and south, and alluvium of the meandering flood plain of Gaddesby Brook to the west and north (Fig. 2). The alluvial deposits

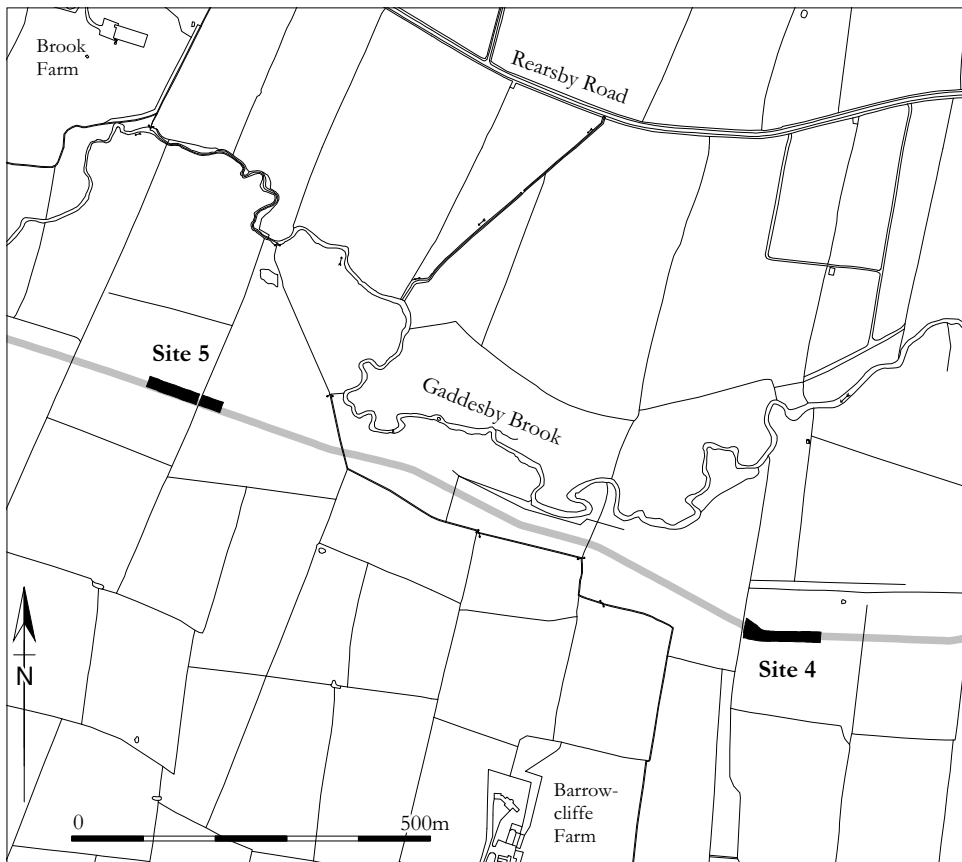

Mapping reproduced by permission of Ordnance Survey on behalf of HMSO. © Crown copyright 2008. All rights reserved. Ordnance Survey Licence number 100021059.

Fig. 2. Location of sites 4 and 5.

included the fills of a palaeo-channel, revealed beneath the ditches at the western end of the site during excavation of the pipe-trench.

Phases 1 and 2: Middle Iron Age to first century AD

A small quantity of handmade, probably middle Iron Age, pottery was recovered from several small linear features at the western end of the site. In all, the site produced 192 sherds of Iron Age pottery, weighing 2,926g and representing at least 98 vessels, though much of this was residual in later features. Gullies 15006 and 15,069 (Figs 3, 4 and 5) both produced relatively large quantities of Iron Age pottery and, in addition, the terminus, 15111, of gully 15006 also contained a relatively large quantity of production waste, identified as Iron Age grey slag. This enigmatic material, which must be the residue of a high-temperature process although it is not at all clear what that might be, has, to date, only been found on Iron Age sites (Cowgill 2005).

Otherwise, few of the features in this part of the site contained good dating evidence, but stratigraphic relationships indicate several phases of use. To take one example of a relatively long sequence: gully 15006 cut terminus 15004, which was probably the same feature as gully 15009 recorded to the north, and was cut by gully 15069. This in turn was cut by gully 15014, one of a series of linear features on roughly parallel east-to-west alignments. Another of these parallel gullies, 15086, produced 26 greyware sherds from the base and body of a jar which bore some evidence of scoring on the body, along with a sherd of shell-tempered pottery (Fig. 7: 3), indicating a date range in the late pre-Roman Iron Age to early Roman period.

Ring gully 15226 produced no datable artefacts but was a stratigraphically early feature, and it seems likely that it was broadly contemporary with the linear features to the south. The surviving segment of this feature was semicircular, with an internal diameter of almost exactly 3m. Iron Age and rural Roman settlement sites commonly contain small ring gullies of this size, variously interpreted as containing storage or working areas, stock pens or perhaps even small domestic structures.

Enclosure 15015

Three sides of a rectangular or polygonal enclosure, defined by a substantial, steep-sided ditch, were visible in the excavation area (Fig. 6). This enclosure seems to have been a long-lived feature, probably established in the Iron Age and re-cut and maintained through the Roman period. This was clearest in the eastern limb which showed two re-cuts of the original ditch, successively displaced to the east. Three fragments of middle Iron Age pottery, weighing 127g, were recovered from the lower fill, 15175 of re-cut 15203, while the upper fill, 15174, contained mid-to late first-century pottery in addition to two sherds of probable Iron Age date.

The western limb of the enclosure demonstrates the difficulties in dating this feature. Much of the pottery recovered from it appeared to be Iron Age, though

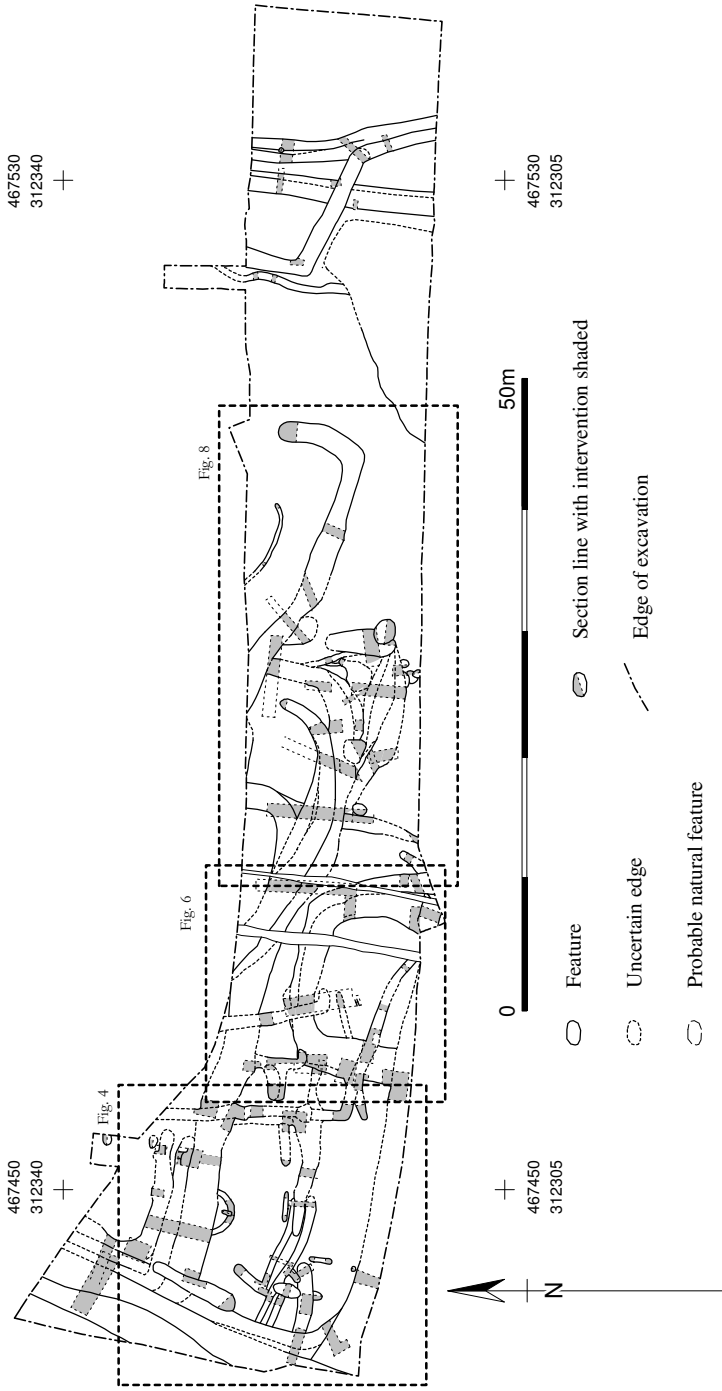

Fig. 3. Site 4, plan of all features.

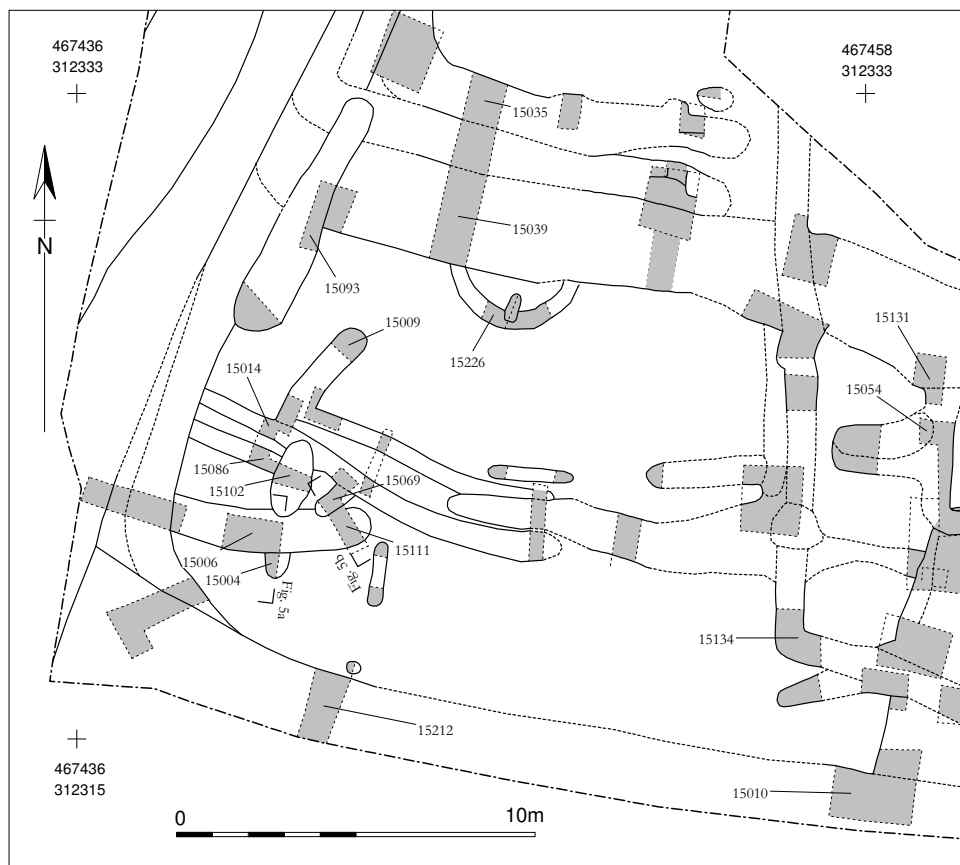

Fig. 4. Western end of site 4, showing Iron Age features.

not closely datable. However, it also produced three third- or fourth-century sherds from its upper fill. In contrast to the other parts of the ditch, no separate re-cuts were noted, perhaps indicating that the whole of this side of the enclosure was re-cut in the later Roman period. Alternatively, this side of the enclosure ditch may have survived as an earthwork feature after it had largely silted up elsewhere.

POTTERY, PHASES 1 AND 2: RUTH LEARY

Two grog-tempered basal sherds and four shell-tempered body sherds from ditch 15169 are likely to date to the mid- to late first century (Clay and Pollard 1994, 75). These six sherds were all abraded. Three later sherds of Romano-British pottery came from ditch 15015: two undiagnostic body sherds and a rim from a shell-tempered jar of late third- to fourth-century date (Brown 1994; Clark 1999, 138; Cooper pers. comm.). Sherds from two vessels recovered during the evaluations and dated to the early Roman period in the mid- to late first century

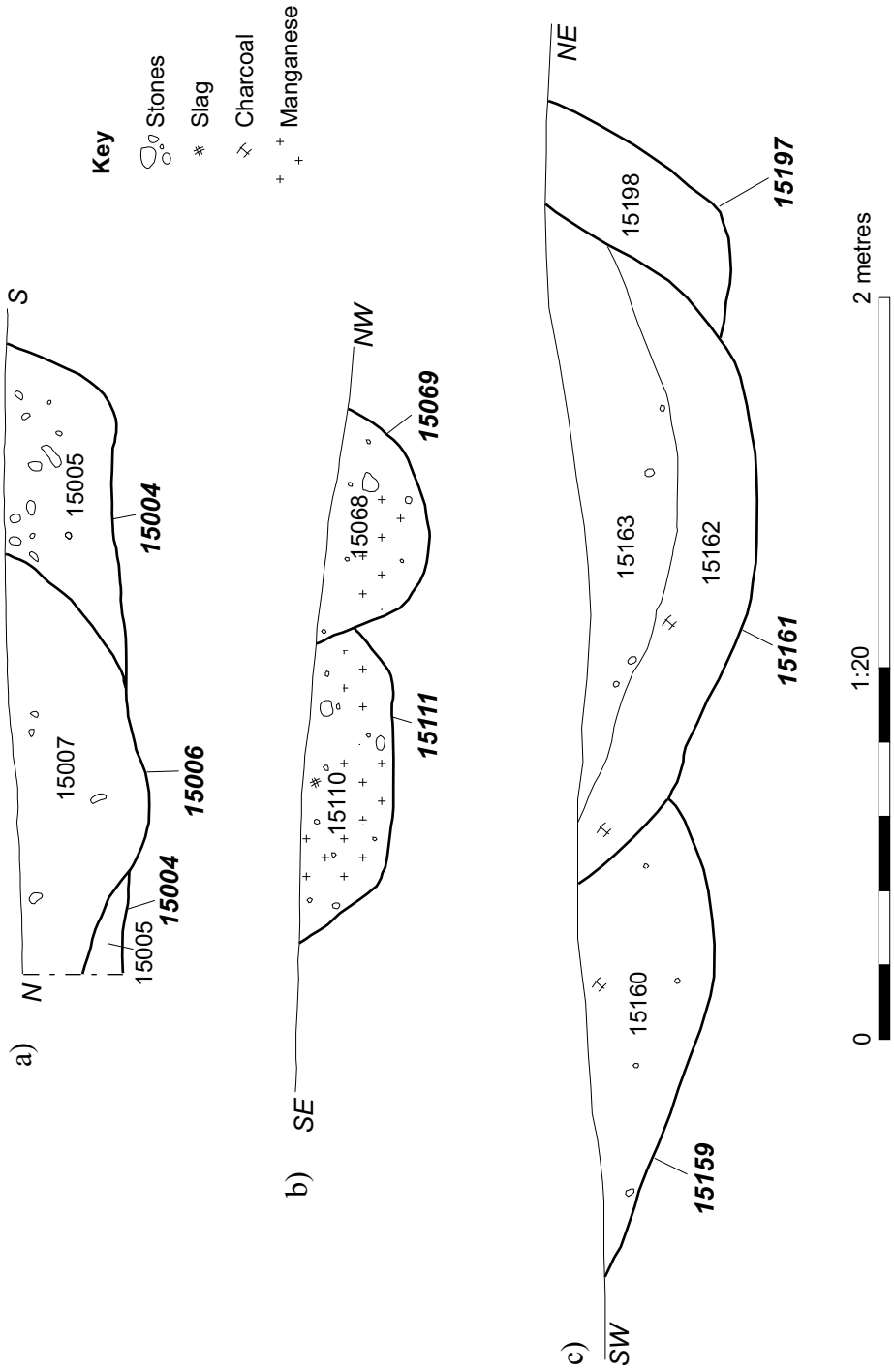

Fig. 5. Sections, site 4 features.

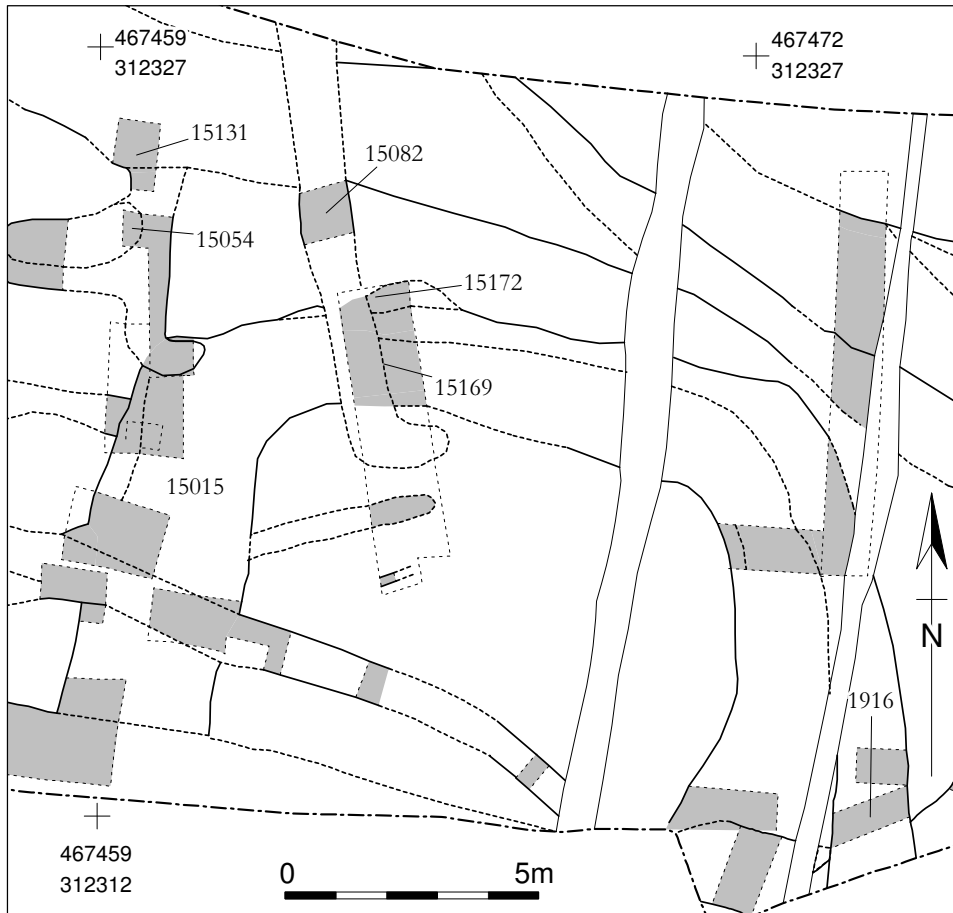

Fig. 6. Enclosure 15015 and associated features.

came from feature 1916, probably the same feature as the enclosure ditch (Fig. 7: 1, 2).

Phase 3: Late first to second century AD

Evidence of activity in the early Roman period was also concentrated in the western part of the site, indicating a general continuity of use through the conquest period (Fig. 4). The upper fill of a small elongated pit or short gully, 15054, was securely dated to the mid-first to second century AD. Pit 15102, which cut gullies 15006 and 15086, also produced a sherd of pottery characteristic of this period.

The system of large ditches crossing the site was probably first established during this period, although some elements may have been in place during earlier phases. Stratigraphic relationships were difficult to establish, as many of these

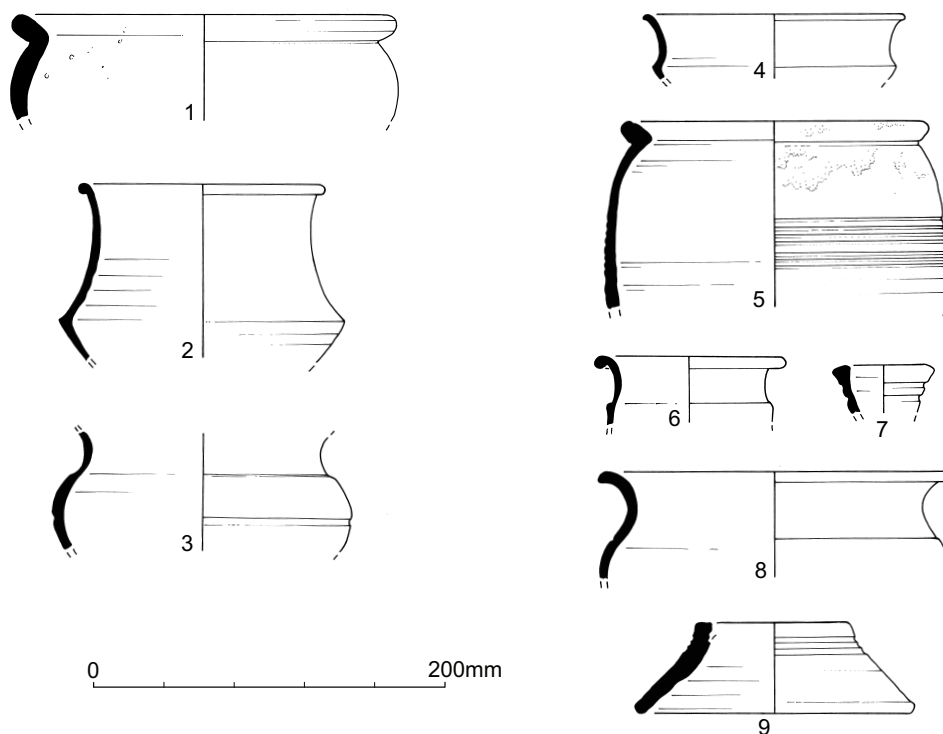

Fig. 7. Pottery site 4, phases 1–4.

features had similar, silty fills, while dating from artefacts is hampered by the occurrence of residual, and possibly intrusive, finds. Nevertheless, a broad chronology can be reconstructed.

Ditch 15039 seems to have been one of the earliest of these ditches: a mid-first to second century date is based on nine fragments of pottery from section 15131, but the relationships in this section are uncertain. Later ditches truncated ditch 15039 to the west, and it is impossible to be sure whether it had been entirely lost or continued as ditch 15233 (Fig. 8). An earlier ditch on a north-to-south alignment, 15264, probably continuing south as ditch 15077, contained a single worked flint, but no other finds, and seems to have belonged to an earlier phase, perhaps forming an eastern limit to the area of Iron Age activity.

Running parallel with ditch 15039 before turning north, ditch 15035 was also an early feature, its northward continuation forming the first of a sequence of five similarly aligned ditches across the western end of the site. A small amount of Iron Age grey slag was recovered from its fill (Cowgill 2005).

PHASE 3 POTTERY: RUTH LEARY

The assemblage is characterised by Roman grey and oxidised fabrics with smaller amounts of transitional wares (Fig. 7: 4 to 8). The diagnostic vessel types indicate

| | |
|---|---|
| 1 | Necked jar/bowl. Fill 15085 of ditch 15086. |
| 2 | Jar/bowl with everted rim, flat inner face, wheel-finished. Burnt or partially oxidised. Fill 1915 of ditch 1916. |
| 3 | Necked bowl with a sloping, sharp carination. A common type group at Leicester undecorated and with cordons and derived from late Iron Age carinated bowls. Fill 1915 of ditch 1916. |
| 4 | Abraded rim sherd from necked bowl with carinated shoulder and rounded rim tip. Fill 15101 of pit 15102. |
| 5 | Six sherds from an everted-rim jar with flat inner face and deep rilling on the shoulder. Much sooting around the rim and upper body; middle to lower body has signs of burning. Upper fill 15052 of ditch 15054. |
| 6 | Abraded, hooked rim sherd from narrow-mouthed vessel with at least one cordon at the base of the neck. Perhaps from a narrow-necked jar. Upper fill 15052 of ditch 15054. |
| 7 | Small rim of ring-necked flagon. The neck is upright with fairly angular rings. Upper fill 15052 of ditch 15054. |
| 8 | Eight sherds from a wide-necked jar with out-curving everted rim. Upper fill 15052 of ditch 15054. |
| 9 | Lid. Fill 15255 of ditch 15254. |

Table 1. Illustrated pottery from site 4, phases 1 to 4.

a date in the late first to early second century. The fabric make-up compares to a group from Causeway Lane, Leicester dating to the early to mid-second century when greywares contributed around 30% and the proportion of transitional or miscellaneous coarse wares had fallen considerably (Clark 1999, 119, table 13).

Phase 4: Second and early third centuries

The sequences of ditch cuts and re-cuts may contain features of this period, but if so, they are not very apparent, perhaps because there was a poorer material culture with fewer diagnostic pottery types, or the focus of activity moved further away from the site. For whatever reason, there seems to have been a marked lull in activity at this time.

A short, heavily truncated remnant of gully, 15254, may provide one exception, as it contained pottery datable to this period, along with two large fragments of ceramic building material, one identified as a brick and the other as a *tegula*.

Along the southern edge of the site, ditch 15010 contained a range of pottery, including some sherds which could be confidently dated to the first or second century. As the pottery was generally abraded and included one third- or fourth-century sherd, this must have been a later feature than ditch 15039, as suggested by the sequence of stratigraphic relationships, but the parallel alignments of these two ditches perhaps implies that they were originally both elements of the same field system, the more southerly ditch having been re-cut or maintained for longer. A moderate amount of hammer scale was noted in a bulk soil sample from the upper fill of intervention 15212, indicating that iron-working had taken place in the vicinity of this ditch, probably on a very small scale, while it was still open.

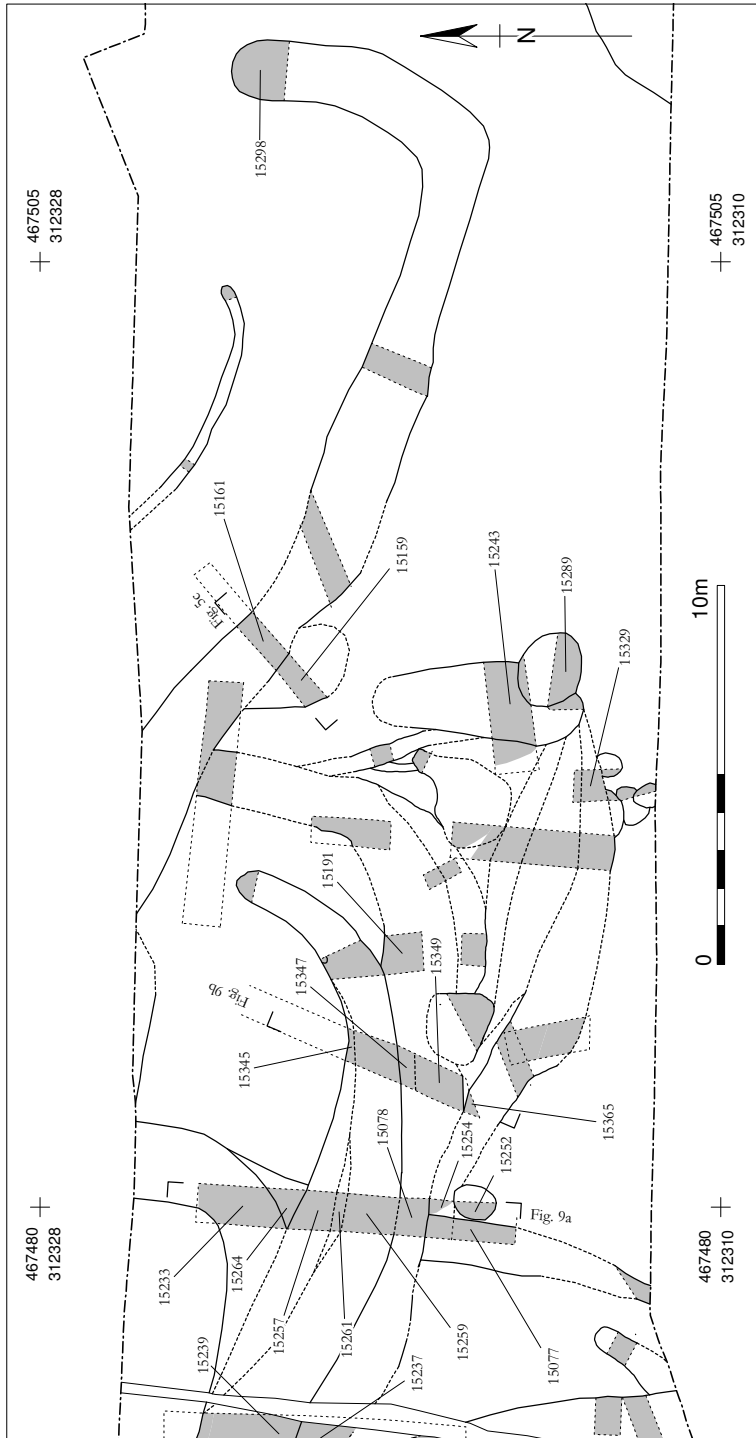

Fig. 8. Features in central part of site 4.

PHASE 4 POTTERY: RUTH LEARY

Very little pottery came from ditch 15254: five greyware body sherds, a small colour-coated sherd and a fragment from a greyware lid. The colour-coated sherd, however, was almost certainly from the same vessel as a sherd from phase 5 ditch 15239 (Fig. 7: 9) dating from the late second or early third to the late third century. Ditch 15093 can be dated to this phase on the basis of a sherd from a greyware bowl with triangular rim dating to the mid- or late second to mid-third century (Perrin 1999, no. 68). A samian sherd from ditch 15212 dates to around AD 70 to 140 and a greyware hooked-rim jar sherd of second or third century date was found in a continuation of this ditch during the evaluation trenching.

Phase 5: Third to fourth century

The central part of the site was dominated by a series of intercutting ditches, mostly dating to the later part of the Roman period (Fig. 9). There seems to have been a slight shift in the general orientation of the site, with these later features being aligned more obliquely to the main axis of the site. Because of the similarity of fills, the individual ditches generally could not be distinguished in plan, and this part of the site was investigated by excavating a number of slots and recording the features in section. It has not always been possible to correlate features between the excavated sections, especially in the southern part of this area.

Ditch 15257 appeared to be an early member of this sequence, but produced six sherds of late third- to fourth-century pottery in addition to a quantity of animal bone and a large fragment of Roman brick. This ditch appeared to be identical with the undated ditch 15191 to the east. A smaller ditch, 15078, was recorded as being a later feature; this ditch may have continued as one of the features seen in the sections to the south.

The latest features in this sequence were the curving ditches 15261 and 15259. The single fill of ditch 15261 produced a small quantity of animal bone, a fragment of Roman *tegula* and 18 sherds of third-century pottery. In addition, a single flint and over a hundred sherds of late third- to fourth-century pottery were recovered from the fill of re-cut 15259. Another re-cut, 15239, contained three fills, the initial and upper fill having pottery dating to the late third to fourth century.

Ditch 15298, which shared the same general alignment as the series of intercutting ditches to the west, produced a range of pottery from its upper fills, including sherds of late third to fourth century date. Few finds came from the ditches at the eastern end of the site, only the upper fill of ditch 15320 containing dating evidence: three sherds of fourth-century pottery.

Two linear features also containing pottery dated to the third or fourth century did not fit the general alignment of the site and may represent a later phase. Gully 15082 was poorly defined, but probably cut both ditch 15039 and enclosure 15015 (Fig. 6). Ditch 15134 (Fig. 4) produced pottery ranging in date from Iron Age to the late third or fourth century AD, as well as part of a box tile.

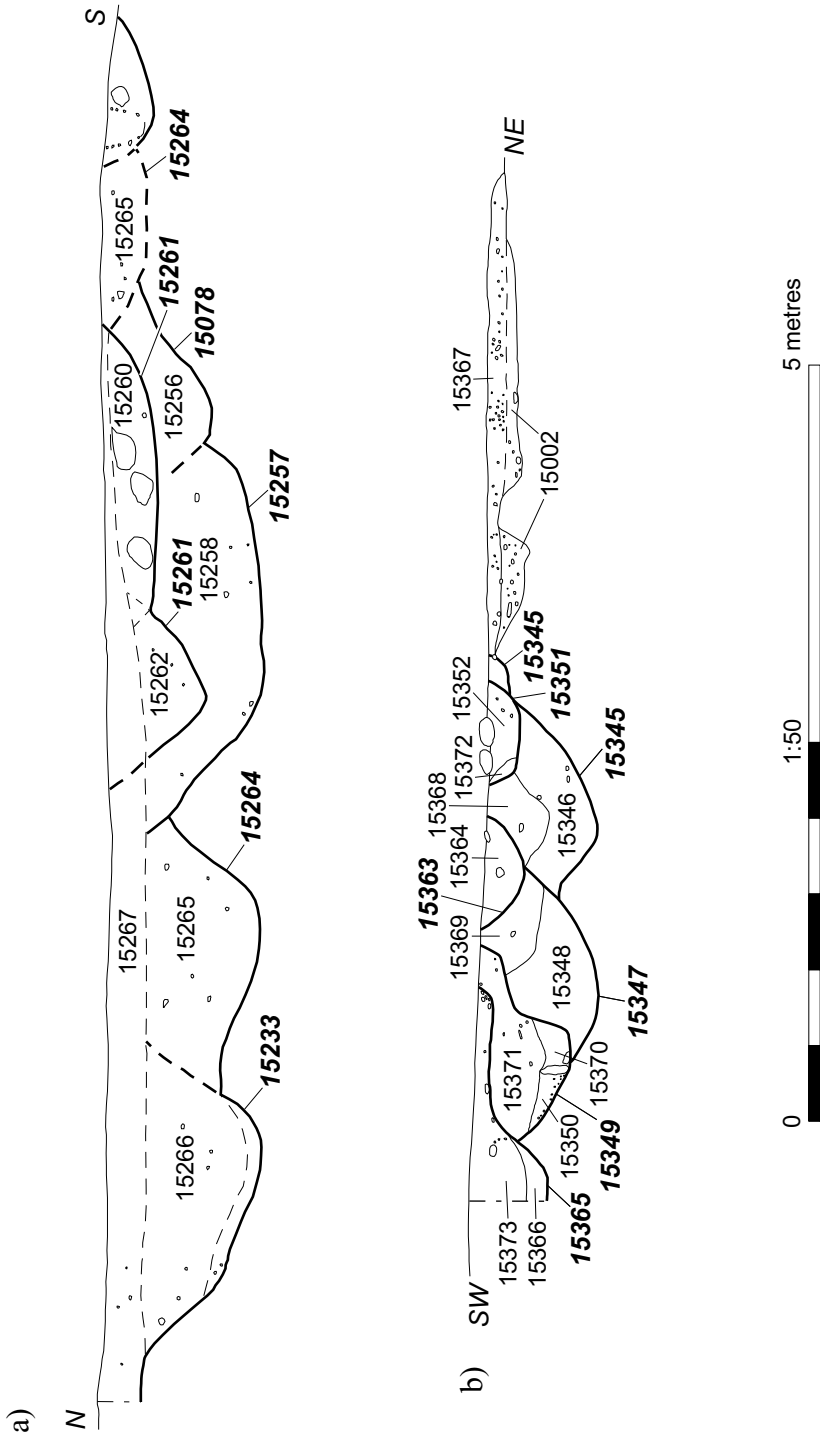

Fig. 9. Sections of ditches in central part of site 4.

Feature 15243 in the central part of the site was probably a section of a broad, shallow ditch but may have been an elongated pit (Fig. 8). It can confidently be dated to the late third or early fourth century. To the south it had been partly truncated by a shallow pit, 15289, which produced a single sherd of undiagnostic pottery. Pit 15252 contained two fragments of late third- to early fourth-century pottery, one of which was a sherd of amphora. A tip of stones within the centre of this feature suggested that this may have been a posthole with a post-pipe and stone packing.

CHARRED PLANT REMAINS: JAMES RACKHAM

A grouping of botanically rich deposits from ditches 15243, 15313, 15327 and 15329, and pit 15289 were conspicuously richer than the assemblages produced from within the series of ditches to the west and east. The composition of the botanical assemblages from this sample group seem to be fairly heterogeneous with grain forming a minor component in all instances and chaff the major component in all but one. These chaff assemblages are typical of residues from the final stages of processing spelt wheat. The accompanying suites of weed seeds support this interpretation in that they are dominated by grasses, many of which are similar in length to the prime grain but are narrower, and were possibly sieved out with the remaining chaff and smaller weed seeds.

PHASE 5 POTTERY: RUTH LEARY

Ditch 15082 contained a fresh sherd from a colour-coated dish of late third to fourth century date in its primary fill, along with greyware sherds belonging to a hooked-rim wide-mouthed jar, and a body sherd with intersecting wavy line burnish decoration from a wide-mouthed or narrow-necked jar, both types common in the third to fourth century. A Nene Valley mortarium from pit 15252 is also dated to the late third to fourth century, although an amphora sherd from this pit can only be broadly dated from the mid-first to the third century. This sherd bore an 'X' graffito.

Ditch 15298 yielded greyware sherds of late second to third century date, a colour-coated copy of a samian vessel dating to the late third to fourth century and earlier sherds such as a shell-tempered storage jar, common in the first and second centuries. Feature 15159 contained sherds from a late third- to fourth-century jar, giving a late *terminus post quem* for this ditch.

The primary fill of gully 15347 was dated to the late third to fourth century by a late shelly ware rim sherd, although it also produced a sherd from a second-century black burnished ware bowl or dish. A rim from a late greyware wide-mouthed jar confirms this dating. A larger group of pottery from gully 15349 included types well dated to the late third to mid-fourth centuries. Gully 15365 contained a sherd with a type of rouletting found in the late third to fourth century at Swanpool, Lincoln (Webster and Booth 1947, type C22).

Of the features recorded in the section to the west, the earliest, 15233, yielded only one undiagnostic basal sherd of a bowl or dish. Sherds of late shell-tempered ware and a bead and flange bowl indicate a late third or, more probably, a fourth

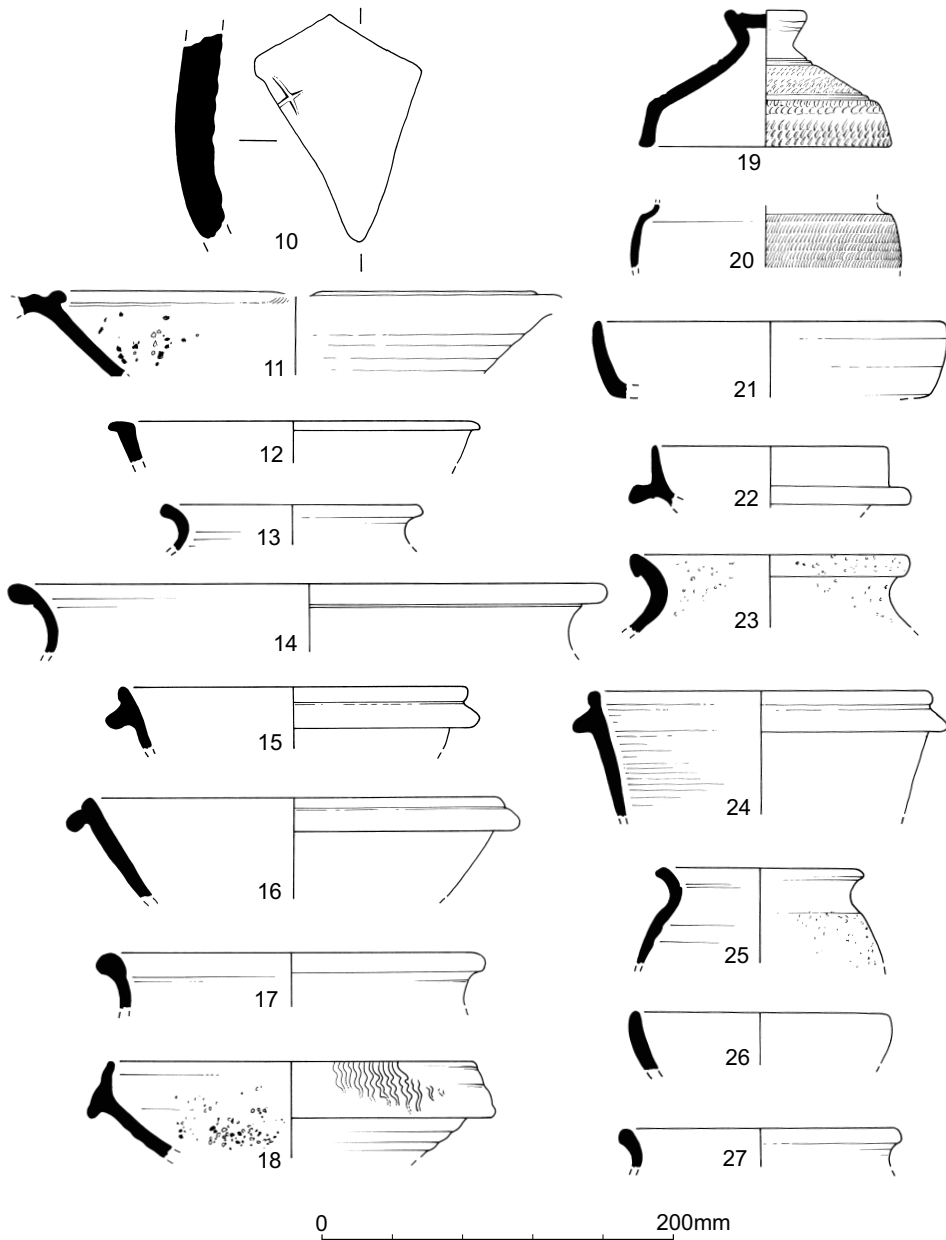

Fig. 10. Pottery site 4, phase 5.

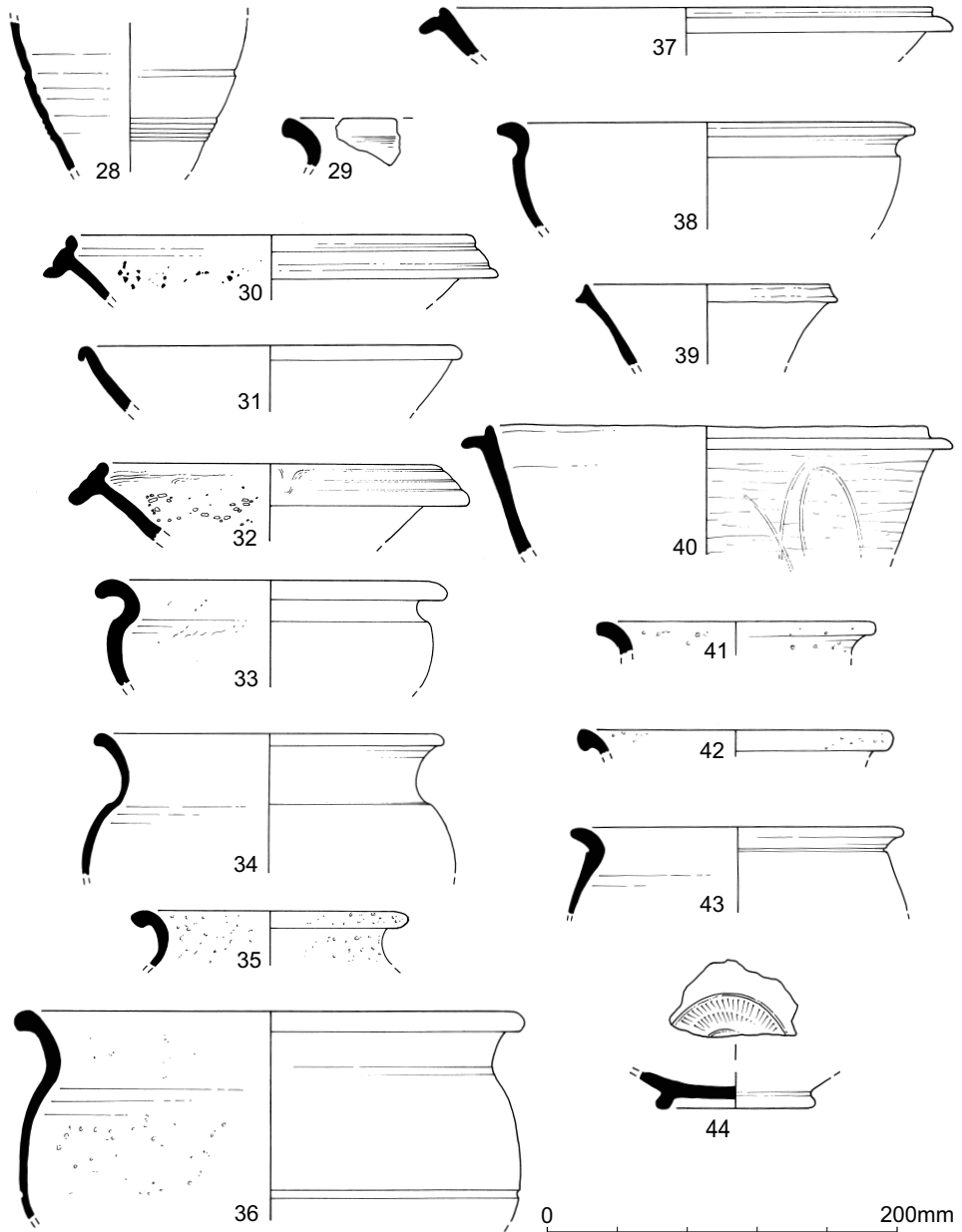

Fig. 11. Pottery site 4, phase 5 and unphased.

| | |
|----|--|
| 10 | Dressel 20 body sherd with graffito. Fill 15253 of pit 15252. |
| 11 | Incomplete rim and body sherd from Nene Valley reeded flange mortarium. Fill 15253 of pit 15252. |
| 12 | Black-burnished ware (BB1) flat rim bowl/dish. Fill 15348 of ditch 15347. |
| 13 | Everted-rim jar. Fill 15348 of ditch 15347. |
| 14 | Wide-mouthed jar. Fill 15348 of ditch 15347. |
| 15 | Bead and flange bowl. Fill 15350 of ditch 15349. |
| 16 | Bead and flange bowl. Fill 15350 of ditch 15349. |
| 17 | Bead rim from wide-necked vessel. Fill 15350 of ditch 15349. |
| 18 | Hammerhead mortarium with orange zigzag painted lines. Fill 15350 of ditch 15349. |
| 19 | Castor box lid. Fill 15350 of ditch 15349. |
| 20 | Sherd from Castor box. Fill 15350 of ditch 15349. |
| 21 | Plain-rim dish. Fill 15350 of ditch 15349. |
| 22 | Flanged hemi-spherical bowl. Fill 15350 of ditch 15349. |
| 23 | Triangular-rim jar, undercut rim. Fill 15256 of ditch 15078. |
| 24 | Bead and flange bowl. Fill 15256 of ditch 15078. |
| 25 | Everted-rim jar with internal groove on rim. Fill 15256 of ditch 15078. |
| 26 | Plain-rim dish. Fill 15163 of ditch 15161. |
| 27 | Everted-rim jar. Fill 15163 of ditch 15161. |
| 28 | Two unabraded sherds from closed vessel with multiple grooves and one groove round the upper body. Perhaps a flagon or jug. Fill 15280 of ditch 15239. |
| 29 | Everted-rim jar. Fill 15280 of ditch 15239. |
| 30 | Collared mortarium. Fill 15280 of ditch 15239. |
| 31 | Mortarium, copy of samian form. Upper fill 15269 of ditch 15243. |
| 32 | Multi-reeded mortarium rim with five reeds. Upper fill 15269 of ditch 15243. |
| 33 | Wide-mouthed jar. Upper fill 15269 of ditch 15243. |
| 34 | Wide-mouthed jar. Upper fill 15269 of ditch 15243. |
| 35 | Everted-rim jar. Upper fill 15342 of ditch 15320. |
| 36 | Sherds from wide-mouthed jar with rounded rim of same form. One sherd has been burnt. Fill 15183 of pit 15172. |
| 37 | Rim of black-burnished bead and flange bowl. Fill 15073 of ditch 15072. |
| 38 | Bead rim, wide-necked jar. Fill 15181 of possible tree root hole. |
| 39 | Unusual bowl with plain rim sweeping out to a flange in a rather triangular form. Fill 15181 of possible tree root hole. |
| 40 | Bead and flange bowl with intersecting arc burnish. Unstratified 15374. |
| 41 | Everted-rim jar. Unstratified 15374. |
| 42 | Triangular-rim jar. Unstratified 15374. |
| 43 | Everted-rim jar. Unstratified 15374. |
| 44 | Rouletted bowl base. Unstratified 15374. |

Table 2. Illustrated pottery from site 4, phase 5, and unphased.

century date for ditch 15078. Ditch 15261 contained sherds of a plain-rim dish and an everted-rim jar which may date as early as the mid-second to third century. Pottery from ditch 15239 included third- and fourth-century types of late shell-tempered ware jars, a Nene Valley dish, a colour-coated pinched neck flagon (cf. Perrin 1999 nos 192–4) and greyware sherds from narrow-necked and wide-mouthed jars with burnished wavy line decoration. Ditch 15259 had similarly dated types including two colour-coated samian copies and a greyware wide-mouthed jar as well as an earlier samian form dated to AD 100 to 125.

Feature 15243 also contained pottery of fourth-century type including colour-coated copies of samian forms, a mortarium and several late wide-mouthed jars. However, the primary fill of this feature contained two small sherds from greyware and black burnished ware jars with everted rims dating to the later second to mid- to late third centuries, so this ditch may have been in use at an earlier date. Ditch 15320 was dated to the fourth century by the late shell-tempered jar from its fill.

Large proportions of two wide-mouthed jars came from pit 15172 along with several late shell-tempered rilled sherds, the rim of a Derbyshire ware jar, a plain-rim dish, a bead-rim wide-mouthed jar and an everted-rim jar. The presence of late shell-tempered ware indicates a late third or fourth century date and the Derbyshire ware is likely to date to before the mid-fourth century (Clark 1999, 136). Six sherds from ditch 15134 included the rim of a grooved-rim dish of late second to fourth century date and a body sherd with the burnished intersecting loops so common on the jars of the third and fourth centuries.

Overall, a date in the late third or more likely the fourth century for this phase is indicated by the proportion of late shell-tempered ware jars. The greyware wide-mouthed and narrow-necked jars, bead and flange bowls and plain-rim dishes are consistent with this date range. A coarser greyware was also used for developed bead and flange bowls, wide-mouthed jars and an everted-rim jar.

The lack of Nene Valley greyware gives a date after the decline in its production by the end of the third century. Similarly the lack of Bourne/Greetham shelly wares, a type common at Leicester in the third century, confirms a late third or fourth century date as does the lack of third-century Nene Valley colour-coated wares. Derbyshire black-burnished wares were present in small amounts; only one example of Oxfordshire red colour-coated ware, a type present from the late third- to late fourth-century groups at Leicester, was identified. Higher proportions of Nene Valley might be expected at a late fourth-century site (Clark 1999, 139) and this, along with the negligible amount of Oxfordshire ware and a date range in the mid-third to mid-fourth century for the mortaria types, suggest that the majority of the groups from this phase date to the early to mid-fourth century. The late shell-tempered jar sherds from contexts stratigraphically early in the sequence imply that third-century activity was minimal.

Unphased, site 4

A substantial boundary defining the western end of the site showed evidence of renewal on at least four occasions, drifting to the west with each subsequent re-cut. Very few artefacts were recovered from the excavated sections and phasing this sequence has proved difficult. The only datable pottery was recovered from ditch 15072: two sherds from the later part of the third century. The stratigraphic relationships suggest an earlier date for this ditch, and it may be that this pottery is intrusive from one of the later ditches or wrongly assigned.

THE BUTTON AND LOOP FASTENER (FIG. 12): HILARY MAJOR

Unstratified surface finds included a button-and-loop fastener, a well-known class of late Iron Age and early Roman artefact. They are strongly associated with military sites, though in this case it is unlikely that there was a military presence on the site. What they were used to fasten is uncertain, perhaps cloaks or horse harnesses. A possibly allied Iron Age form, a circular ring with a stud on the edge, is thought to be a baldric or belt fitting; a belt-hook of similar form was found *in situ* in a late La Tène warrior burial at Owlesbury (Collis 1973, 126ff).

This button-and-loop fastener does not fit very comfortably into the typology produced by Wild (1970). It could be seen as a variant on Class V, cast circular fasteners with the loop set in the centre. However, the shape of the loop and its setting on the edge of the disc are more reminiscent of Class II, ring-headed fasteners of native, rather than Roman, ancestry. These are often quite elaborate; a large group of decorated examples came from the Stanwick hoard, dated to the mid-first century AD (MacGregor 1962). This example is much plainer, but is probably of similar date, and of British manufacture.

SITE 4 POTTERY, GENERAL: RUTH LEARY

In total, 529 sherds weighing 9,911g were retrieved from the site, the majority of these coming from the ditches and re-cuts dating to the early fourth century.

Taphonomy and sherd conditions

The Romano-British pottery from the earlier phases is somewhat abraded and fragmented whereas that from phase 5 is considerably less abraded and had a greater sherd weight, indicating that it was freshly deposited. Fragile fabrics, such as the shell-tempered wares weakened by the loss of shell inclusions, are more fragmented

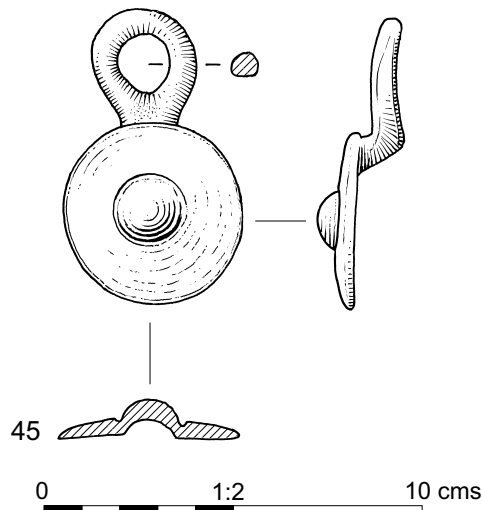

Fig. 12. Button and loop fastener, site 4.

and abraded, but in phase 3 it is the robust greywares that show high fragmentation suggesting that these groups consist of material which was weathered or trampled in a midden or which came from deposits that had been disturbed. This suggests that the larger late group represents rubbish deposited in abandoned features whereas the earlier small groups were casual leavings, at times when the area was kept clean and the ditches cleared out regularly. The phase 5 ditches produced two collections of sherds, each making up the greater proportion of a single vessel (nos 19 and 36). One of these is a Castor box lid, a quite fragile item unlikely to have survived had there been any significant post-depositional disturbance.

Spatial analysis, functional groups and site status

The Romano-British pottery sherds were concentrated overall in the middle of the excavated area. The largest phase 5 groups came from ditches 15239 and 15243. This area seemed to be a favourite place to dump ceramic debris and may have been sufficiently close to an adjacent settlement to have been convenient for the disposal of domestic waste.

The proportion of tablewares in the assemblage rose over time and the proportion of jars fell. No dishes suitable for serving food (Cool 2006, 165) or drinking cups were present in phase 3, but a flagon rim and some white ware body sherds likely to come from flagons were noted, so drinking vessels were presumably in use, perhaps made of an organic material, such as leather or wood. Although the overall proportions of jars fall over time, wide-mouthed jars became more common in phase 5. This is a pattern detectable to the north in the East Midlands and Yorkshire (Todd 1968; Leary forthcoming) and may indicate changes in dining habits, perhaps to a situation where diners helped themselves from large open tureen-type vessels.

The lack of narrow-necked jars in phase 5 is undoubtedly an accident of survival since body sherds of this type of vessel were certainly present. In a group of similar date from the site 9 well (see below), this vessel type was well represented. It may be that these jars, often associated with wells and storage of liquid, were not incorporated in domestic debris to the same extent as other vessel types since they tended to be broken away from the domestic quarters, at the well or in a storage or washing area (Leary in prep.).

The rise in the relative numbers of bowls and dishes in phase 5 indicates a shift towards Romanised dining habits with foodstuff laid out on a plate for individual consumption (Cool 2006, 165). The presence of the distinctive Castor box form may be a similar indicator of sophisticated dining habits, and the mortaria, although not necessarily linked with Roman customs, indicate the adoption of food preparation habits most common in Roman Britain.

Compared with similar dated groups from Roman Leicester, this rural site appears to be some 200 years behind, with the proportion of bowls and dishes in early to mid-fourth century phase 5 comparing to the early second-century phase at Leicester. The principal difference between the urban and the rural sites, however, lies in the quantities of drinking vessels (22% in phase 2 at Leicester) along with the more pronounced presence of jar forms. This fits in with

| Vessel type | Phase 1 | Phase 3 | Phase 4 | Phase 5 | Unphased | All |
|---------------------------------|-------------|-------------|-------------|-------------|-------------|-------------|
| Bowl | | 21.9 | | 17.6 | 28.5 | 20.5 |
| Bowl or dish | | | 25.0 | 1.3 | | 1.4 |
| Dish | | | | 11.3 | | 6.7 |
| <i>All bowls and dishes</i> | | 21.9 | 25.0 | 30.3 | 28.5 | 28.5 |
| Beaker | | | | 2.1 | 14.6 | 5.2 |
| Flagon | | 9.4 | | | | 1.0 |
| M-necked jar | 100.0 | 21.9 | | 19.2 | 19.2 | 19.7 |
| N-necked jar | | 15.6 | | | 14.6 | 5.7 |
| W-mouthed jar | | 31.3 | | 37.9 | 23.0 | 32.0 |
| <i>All jars</i> | 100.0 | 68.8 | | 57.1 | 56.9 | 57.4 |
| Lid | | | 75.0 | 4.0 | | 4.1 |
| Mortarium | | | | 6.5 | | 3.8 |
| Total EVES | 0.07 | 0.96 | 0.20 | 5.22 | 2.39 | 8.84 |

Table 3. Site 4, relative quantities of vessel types by phase.

observations elsewhere (Evans 1993 and 2001) although the quantities of bowls and dishes present in the area of modest accommodation at Causeway Lane, Leicester are rather low compared with other urban sites (Evans 1993, fig. 7, approx. 40–50% on second century sites). The level of bowls and dishes in phase 5 at site 4 may indicate a relatively high status for a rural site (Evans 2001, figs 5–6, villas approx. 28%) especially when the generally low level at Leicester is taken into account.

Pottery supply

Most of the pottery at site 4 is likely to be locally produced. The early shell-gritted wares were absent and grog-tempered wares accounted for 11% of the group with a further 32.4% of mixed gritted wares. Clark suggests that the early shell-gritted ware was traded from Bedfordshire (1999, 120 and 125) and the absence of these wares on rural settlements indicates the use of locally-produced alternatives. The white wares, on the other hand, were clearly not local products but were obtained through trade centred on Leicester and obtained in similar quantities to that at sites in Leicester. Other traded wares such as samian, amphora, continental traded wares and black burnished wares were rare on site 4.

During phase 5, the assemblage contrasts with Leicester in the large proportion of greywares. By weight, the colour-coated wares were more common at site 4, at nearly 6%, than at Leicester (3% by weight), and may be compared to an even greater proportion at Wymondham villa near Melton Mowbray (Leary unpublished). By contrast the proportion of late shell-tempered wares at both site 4 (6%) and at Wymondham (approx. 10%) is similar to that at Leicester (10%) by weight. The trade network for this vessel or commodity clearly reached these rural sites. The black-burnished wares (BB1), however, did not appear on site 4 in any great numbers, whereas at Wymondham they made up around 7% (by count and weight) of the assemblage. This may be because the late Nene Valley colour-coated bowls and dishes and the shell-gritted ware jars along with local greyware

vessels met the needs of the rural population at site 4. The presence of an Oxfordshire red colour-coated ware bowl at site 4 indicates the continuation of long-distance exchange in the late third to fourth century, presumably via markets at Leicester, but highlights its limited nature.

Discussion, site 4

The general alignment of the site seems to have been maintained from the earliest dated activity in the middle Iron Age through to the early Roman period. This argues for a broad continuity of use throughout this span of time, although the site seems to have been much less intensively used in the middle years of the Roman period, judging from the comparative lack of finds. The third- or fourth-century ditches were on a rather different orientation, the axis of the site having moved slightly towards a north-west to south-east alignment. At the same time, the focus of activity moved towards the east.

If the site ever extended to the west, beyond the line of the modern field boundary, all evidence of this has been destroyed by subsequent cultivation, but this seems unlikely. This boundary follows the course of an old stream which would have run from a small valley in the high ground to the south and now occupied by an area of woodland, Sherrard's Spinney. The course of this stream was presumably sufficiently prominent a feature to form a natural boundary at the time when the site was occupied.

The features at the eastern end of the site, though poorly dated, seem to mark the extent of the site to east. As such, their relative remoteness from the main area of activity might account for the general lack of artefacts recovered from them.

It is likely that the primary function of the linear features was drainage and their alignment would have been largely dictated by the local topography, leading westward to the former watercourse at the western end of the site. The more substantial ditches would have also served as land division markers. The environmental samples produced very little material and give little information about the function of the site, but the ditches presumably formed part of a small agricultural settlement. The quantity of artefacts, especially the pottery assemblage, suggests habitation, either within the area of the site in structures which have left little or no evidence in the archaeological record, or very close by beyond the limit of the pipeline working width.

SITE 5: IRON AGE AND ROMAN FEATURES

Queniborough Parish, NGR 466655 312655

Introduction

Site 5 consisted of intercutting systems of rectilinear ditches and gullies, a number of pits and postholes, several burnt features interpreted as hearths or kilns and a metalled surface, probably a trackway (Fig. 13). A single human burial was also

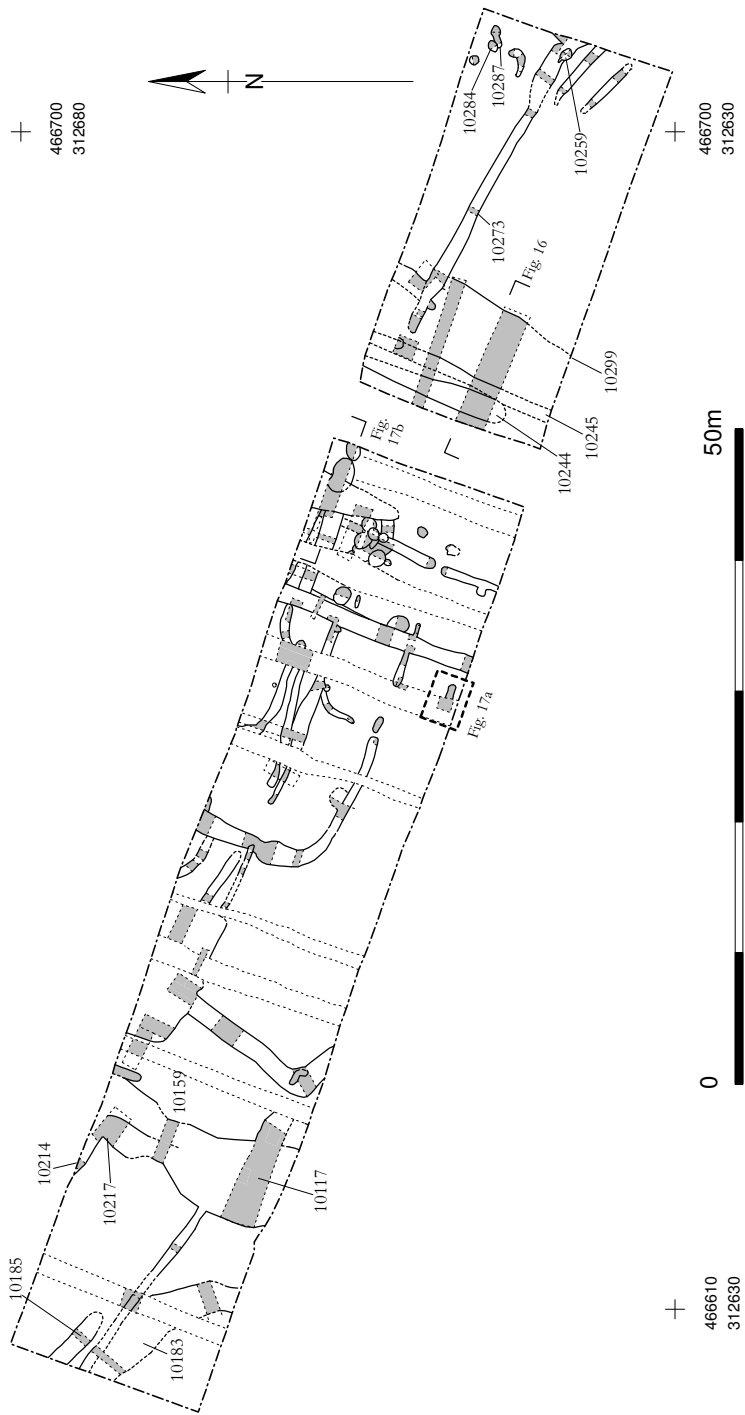

Fig. 13. Site 5, plan of all features.

recorded. Artefacts ranged in date from the early first to the fourth centuries, with activity peaking in the second half of that range.

This site extended either side of an existing field boundary hedge on fairly flat ground, at around 68m AOD, slightly raised from Gaddesby Brook and its flood plain to the north (Fig. 2). To the south the land rises over a low ridge before descending again towards Queniborough Brook, beyond Croxton Road. Glacial drift deposits of orange sands and grey boulder clays underlie the site, with some colluvial silts in the lower-lying areas.

The preconstruction geophysical survey showed linear magnetic anomalies crossing the pipeline route just to the west of the field boundary (NAL 2004) and as a result the area was targeted for trench evaluation. Three excavated evaluation trenches confirmed the presence of features dating to the Roman period (NAL 2005). Stripping of topsoil from the full working width of the pipeline showed that these features extended for approximately 75m west and 30m east of the field boundary.

Phase 1: Pre-Roman

Towards the western end of the excavation area, ditch 10159 was probably established in the late Iron Age (Fig. 13). It is on a different alignment to the rectilinear ditches to the east, and its fill produced the earliest pottery from the site, five sherds dating from the pre-conquest period. However, there is evidence that it survived into the Roman period, as three abraded scraps of Romano-British pottery, none closely datable, were recovered from it. Although only one fill could be distinguished, the stepped profile of the ditch suggests that it may have had unrecognised re-cuts.

The area to the west of ditch 10159 was low-lying and the recorded features were poorly defined and lacking in dating evidence. The alignment of several of these features, particularly ditches 10214, 10217 and 10185, however, suggests that they formed part of the same system of ditches as ditch 10159.

ANIMAL BONE: JENNIFER WOOD

Pairs of cattle mandibles and horse mandibles were recovered from ditch 10159, but it is uncertain if these are significant in their placement or just a result of random sampling of the section of ditch. The cattle mandibles were from an animal retained to an old age, presumably kept for milk production or traction rather than for meat.

Phase 2: First century AD

Gully 10166 produced three shell-tempered pottery sherds, probably dating to the later first century AD and indicating that this was one of the earliest features in the central part of the site (Fig. 14). A piece of samian pottery from the Flavian period, AD 69 to 96, was retrieved from pit 10284, one of a cluster of pits in the north-east corner of the site (Fig. 13), but this is likely to have been residual, as a similar

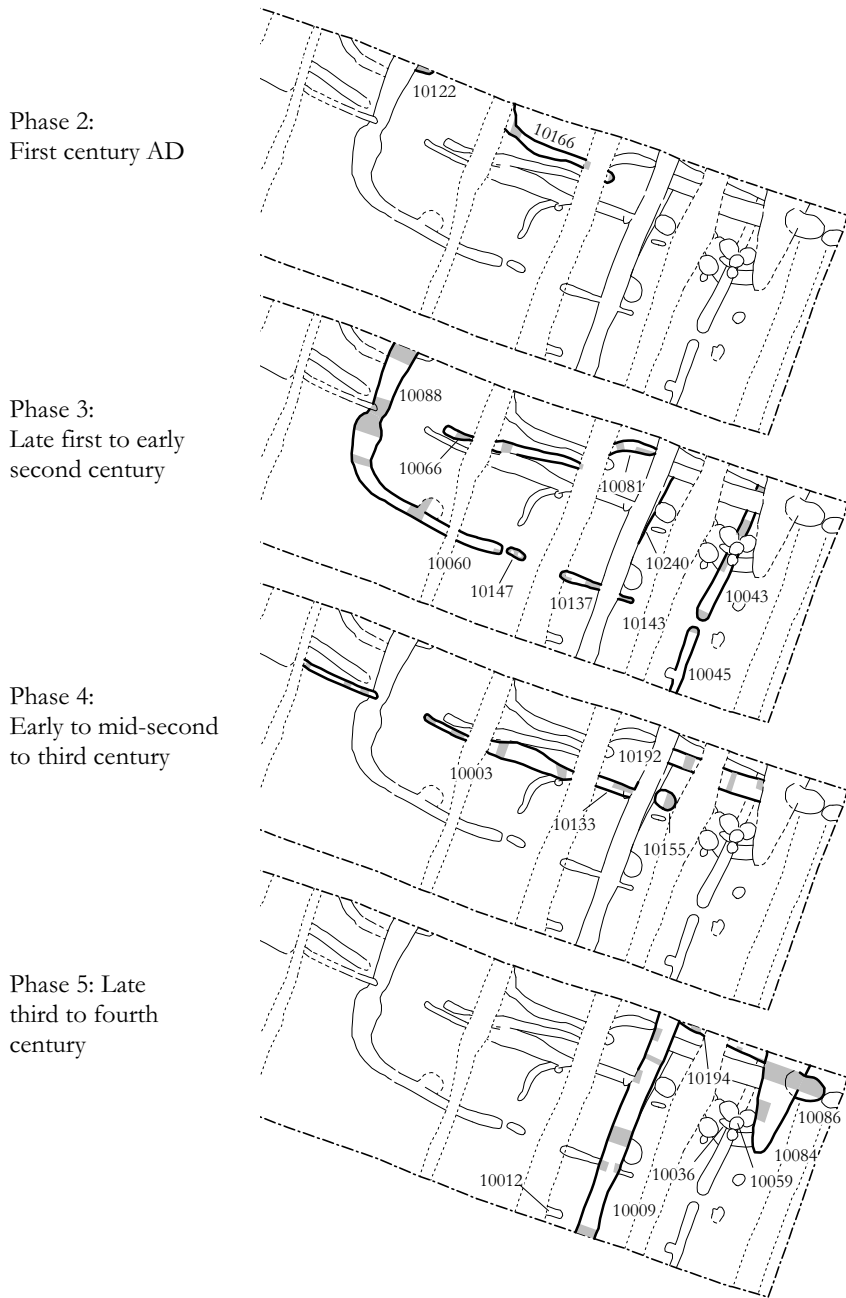

Fig. 14. Phase plans of central part of site 5.

pit to the south, perhaps broadly contemporary, was a stratigraphically late feature.

Pit 10122, which was only partly exposed within the excavation area (Fig. 14), contained a circle of large rounded stones below a dark, organic clay fill, in appearance like the lining of a well, but only a single course deep. The pit produced no datable artefacts, but was cut by a phase 3 ditch. A bulk sample taken from the organic upper fill produced the richest assemblage of botanical remains from the site, with an abundance of cereal grain, mostly spelt-type wheat with small quantities of hulled barley and oat. The small amount of weeds and chaff suggests that this was cleaned grain rather than crop-processing residues.

Phase 3: Late first to early second century

The ditch system in the central part of the site was developed during phases 3 and 4 (Fig. 14). Ditches 10043 and 10045, 10137, 10060 and 10088 were almost certainly contemporary, along with ditch 10240, largely destroyed by a phase 4 re-cut, and pit 10147, containing two postholes in its base. Gullies 10066 and 10081 were aligned rather differently, and may have been of an earlier or later sub-phase, but their artefact assemblages indicated a similar date range to the other phase 3 features.

PHASE 3 POTTERY: RUTH LEARY

The pottery was rather abraded with a low average sherd weight: just over 10g compared to 18g at site 4. Of the total of 187 sherds of pottery from phase 3 features, 117 were from gully terminal 10066. The presence within the group of several vessels which would be expected in a late first- or early second-century context (Fig. 15: 46 to 50) suggest that accumulation took place at this time.

The other phase 3 assemblages were small. Three greyware sherds from gully 10043 came from a carinated bowl type of late first to early second century date. Sherds from a greyware wide-mouthed jar from ditch 10088 and a flanged hemispherical bowl from gully 10081 are of a similar date. The low level of early and transitional wares confirms a date in the early second century for these features.

Phase 4: Early to mid-second to third century

Immediately to the east of the modern boundary hedge, a 6m-wide layer of stone apparently formed a metallated surface. It did not extend as far as the southern limit of excavation, suggesting that it may have been a building platform, but an interpretation as a linear trackway seems far more likely. It was on roughly the same alignment as the modern field boundary. The feature consisted of a shallow hollow, 10299, with a metallated surface, 10244, on its western side (Fig. 16). This surface had slumped into the hollow. Layers of silt had then accumulated over the stones of both the trackway and the slumped fill of the hollow. This was covered by a more organic upper layer, possibly the slumped remains of a bank.

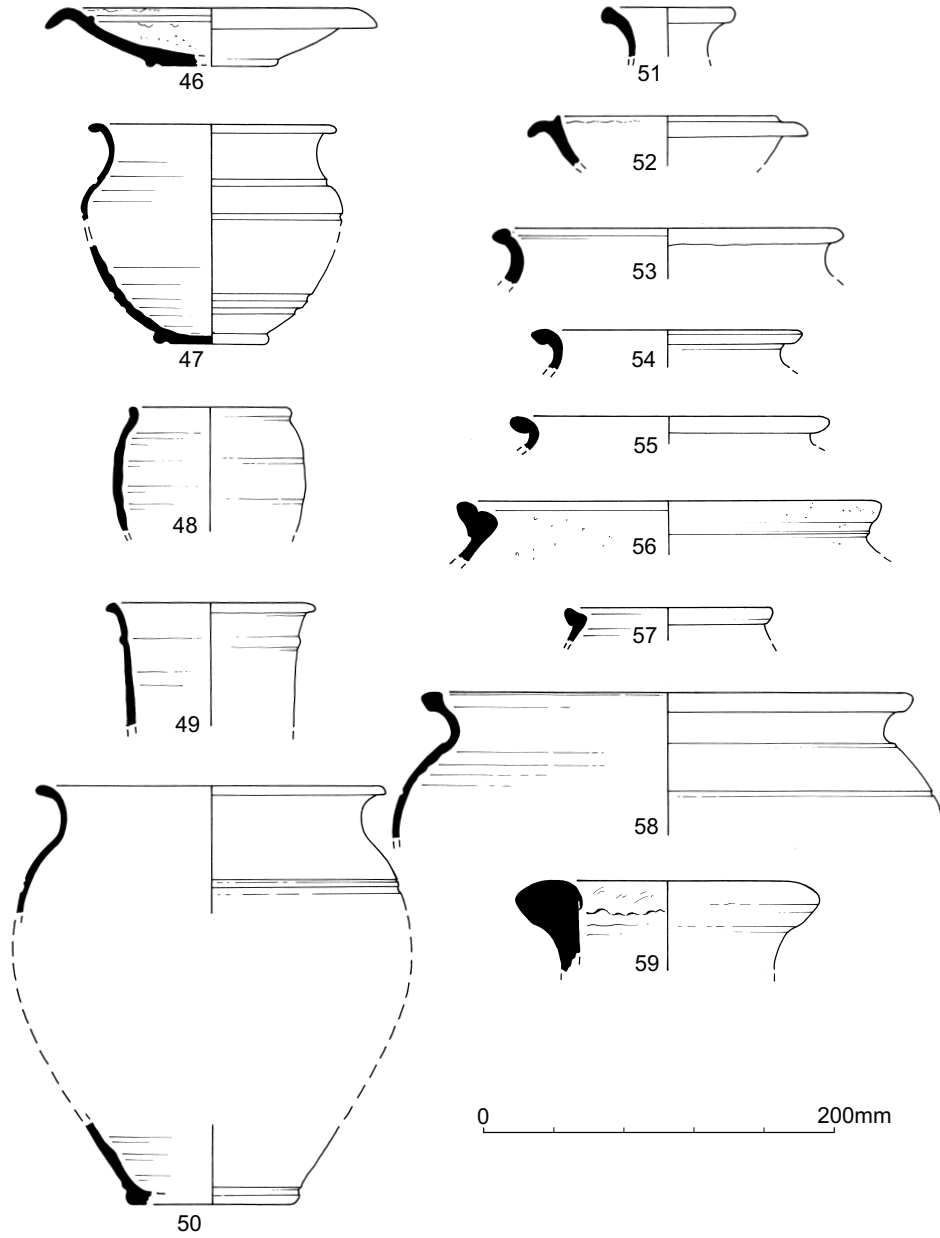

Fig. 15. Pottery site 5.

| | |
|----|--|
| 46 | Flanged hemi-spherical bowl with turned base. The flange rises above the level of the beaded rim. The surface retained on the base indicates this vessel originally had a good black surface. Fill 10067 of ditch 10066. |
| 47 | Wide-mouthed jar with footring base and bulging shoulder between two grooves. The sherds do not join to make full profile but seem to come from the same vessel. Fill 10067 of ditch 10066. |
| 48 | Small jar with rounded slightly expanded rim. Fill 10067 of ditch 10066. |
| 49 | Fragments from a cordoned bowl. The non-adjoining sherds come from the same vessel which is carinated with a cordon or possibly two outside the upper body. Fill 10067 of ditch 10066. |
| 50 | Wide-mouthed jar with everted rim. Fill 10067 of ditch 10066. |
| 51 | Bead rim of narrow-necked jar or flask. Layer 10300 of trackway 10299. |
| 52 | Flanged hemi-spherical bowl. Layer 10309 of trackway 10299. |
| 53 | Neck and rebated bead rim of wide-mouthed jar. Grave fill 10119. |
| 54 | Triangular everted rim. Fill 10083 of ditch 10084. |
| 55 | Everted-rim jar. Fill 10083 of ditch 10084. |
| 56 | Rebated-rim jar. Unstratified 10001. |
| 57 | Rebated-rim jar. Unstratified 10001. |
| 58 | Unusual jar with everted, rebated rim. Furrow 10107. |
| 59 | Dressel 20 amphora rim. Fill 10087 of pit 10086. |

Table 4. Illustrated pottery site 5.

The surface of the trackway and the overlying layers produced a relatively large assemblage of Roman pottery and other artefacts. Although there was some mixing of deposits, the finds from within the lower stone layer were of early to mid-second or third century date, implying that the trackway was in use during this phase. Stones within the silt layer may represent efforts at repair, but the trackway probably fell out of use in phase 5 (below).

The alignment of the trackway respects the phase 3 features, seeming to form their eastern limit. The overall pattern of the rectilinear ditch system was maintained through phase 4, with gullies 10003 and 10192 probably feeding into a re-cut of ditch 10240.

PHASE 4 POTTERY: RUTH LEARY

Ceramics from the trackway include the two illustrated pieces (Fig. 15: 51 and 52) along with samian sherds dated AD 160–240 and AD 150–200, a samian roundel, an earlier first- to mid-second-century bead-rim jar, part of an early to mid-second-century ring-necked white ware flagon, everted-rim jars, black-burnished sherds, a Nene Valley greyware sherd, a fragment from a Midlands mortarium, and a wide-mouthed jar with an undercut rim.

Layer 10246 yielded a wide-mouthed jar with bead rim of later third- to fourth-century type, while layer 10308 produced five sherds from two Mancetter-Hartshill mortaria (Gillam 1971, type 264) dating to the late second to early third century, Antonine (AD 138–92) samian sherds, and a black-burnished ware jar base. Amphora sherds from bank 10301 are likely to be first century AD although the form continued in use up to the early third century. Layer 10245 yielded a rim sherd from a colour-coated long necked beaker of late third or fourth century date.

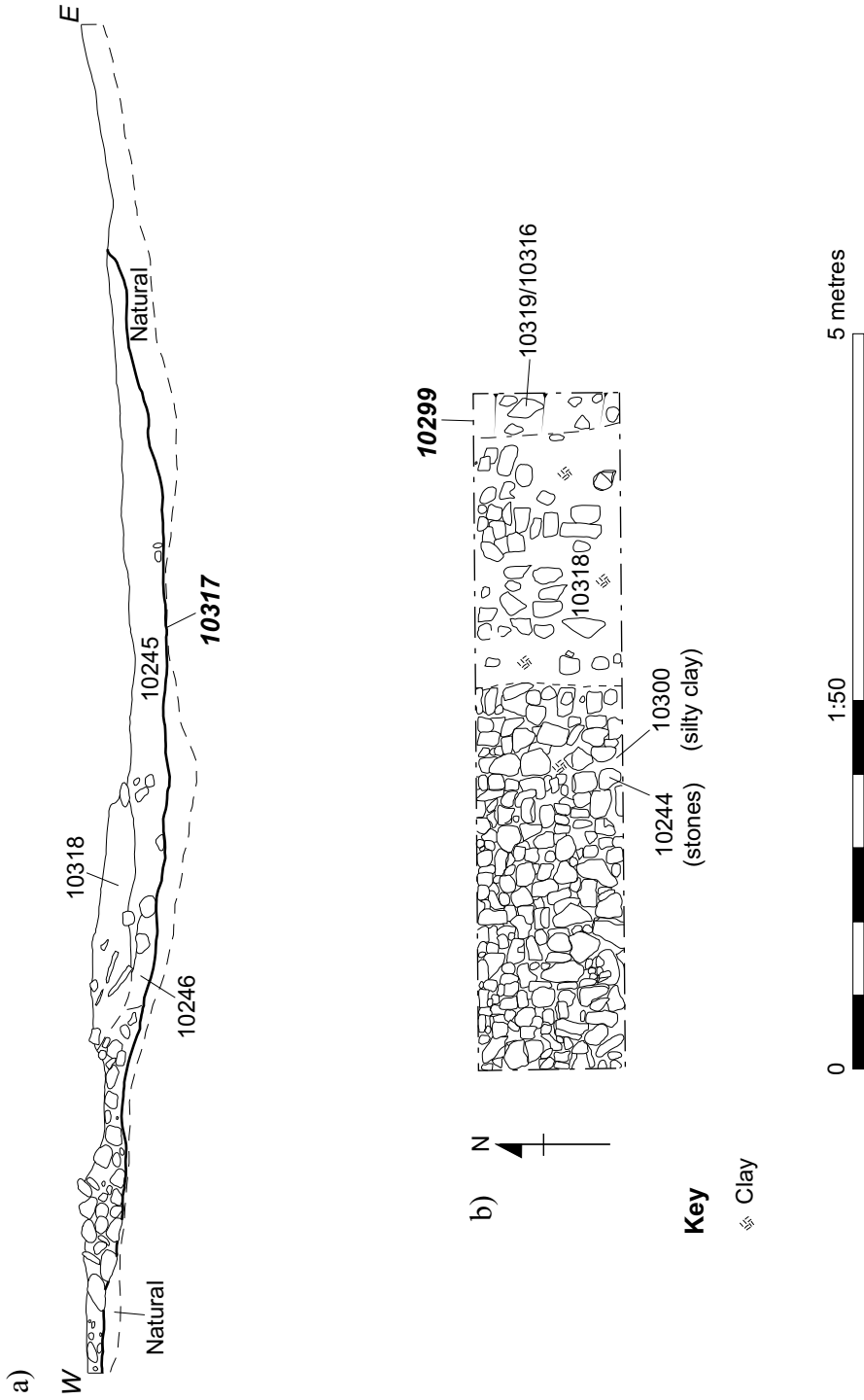

Fig. 16. Section and plan of site 5 trackway.

Elsewhere on the site, the upper fill of ditch 10223 included a rim and body sherd from a Nene Valley scale beaker of the early third century as well as sherds from a first to mid-second-century rebated-rim jar. A wide-mouthed, everted-rim jar from the primary fill of ditch 10192 is probably of second century date and a black-burnished plain-rim dish from pit 10155 indicates a date in the later second century. The group from ditch 10133 was not closely datable except for a wide-mouthed jar of mid-second- to third-century type (Perrin 1999, nos 33–40). A wide-mouthed jar and medium-necked jars with everted rims from ditches 10201 and 10047 belong to the later second to third centuries.

Phase 5: Late third to fourth century

Grave 10117, cut into the fills of the phase 1 ditch 10159, contained the remains of a skeleton, severely fragmented and eroded. The skeleton was of a mature adult male of muscular build, who had suffered from poor dental health, including cavities and dental abscesses (Holst 2005). Unless the siting of the burial in the angle of the ditch was purely accidental, the ditch or the boundary that it marked must still have been a feature of the landscape in the late third century.

Further east, ditch 10009 represented the latest re-cut of a north-to-south aligned ditch. Its relationship with ditch 10094 was not clear, as they intersected close to the edge-of-site baulk, but the finds suggest that they may have been contemporary. Magnetic material in the fill of ditch 10009 probably derives from the remains of a hearth or fire thrown into the ditch; an unphased oven-like feature, 10012, near the southern edge of excavation is a possible source. A cattle metacarpal recovered from ditch 10194 had a hole drilled into the proximal articulation, possibly representing an offcast from bone working.

Two features excavated near the northern baulk of the site, just to the west of the modern field boundary, produced comparatively rich finds assemblages. Pit 10086 and the wide shallow ditch which cut it, 10084, had similar pale silty fills containing large cobbles, and could only be clearly distinguished in section (Fig. 17).

PHASE 5 POTTERY: RUTH LEARY

The fill of the grave 10117 contained a sherd from a wide-mouthed jar with rebated, bead rim (Fig. 15: 53). This is not closely dated typologically but the fabric and general form suggest a date range in the third or fourth century.

One of the interventions in ditch 10009 produced a late shell-tempered everted-rim jar which belongs to the fourth century, although earlier material from the ditch, such as a black-burnished ware jar of mid-second century date (Gillam 1976, no. 2) and an everted-rim jar, recovered in the evaluation trenching (NAL 2005), might give a second or third century date for the feature. Sherds from ditch 10194 include a carinated bowl and a fourth-century jar sherd.

Ditch 10084 and pit 10086 produced 47 and 61 sherds respectively. A further 14 sherds came from features 2423 and 2435 in the evaluation trench (NAL 2005), probably the same feature as ditch 10084. Ditch 10084 included sherds

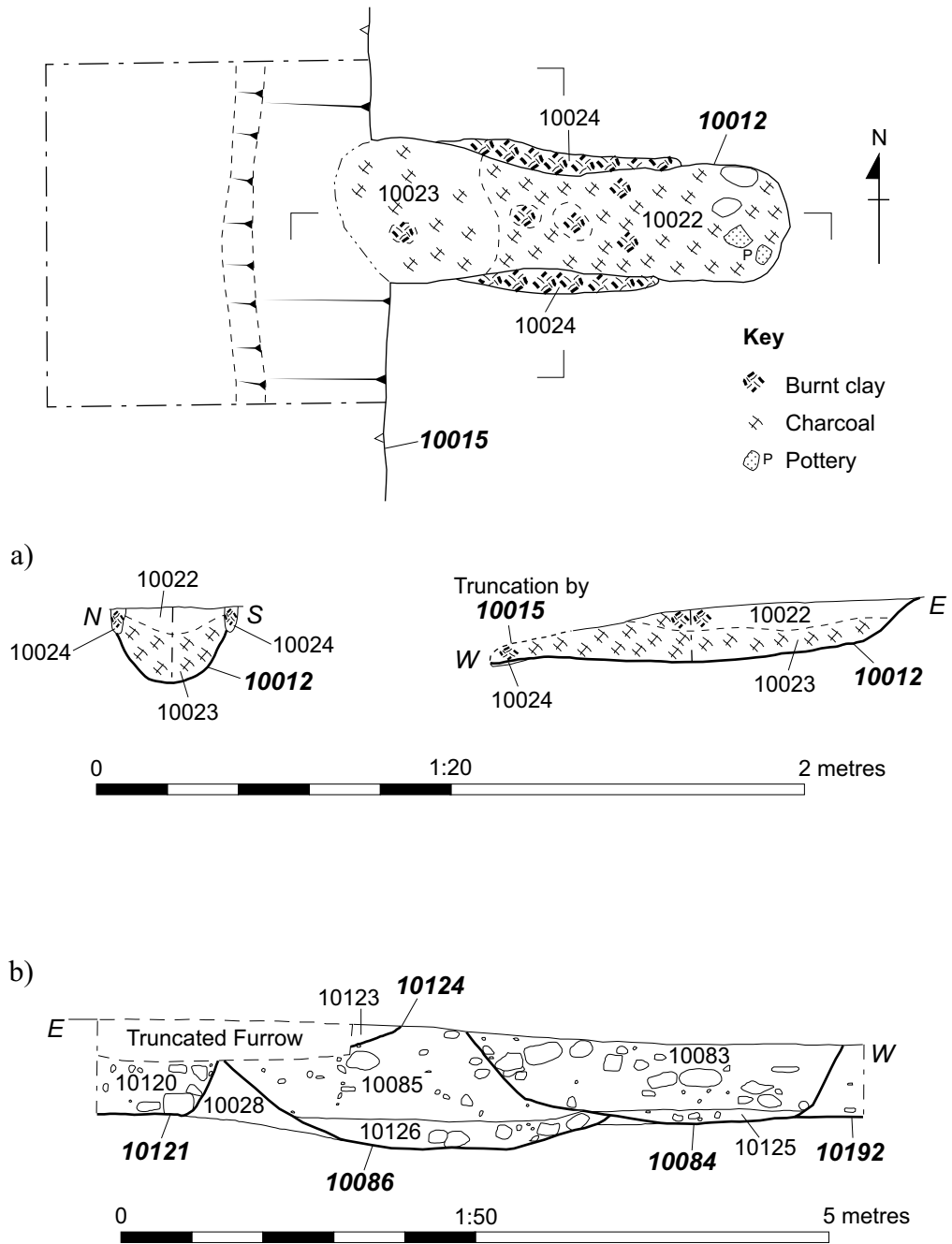

Fig. 17. Site 5, plan and sections of oven 10012 (a), and section through ditch 10084 (b).

from at least two everted-rim jars (Fig. 15: 54 and 55) suggesting that pottery was still accumulating in the late third or fourth century. Other types from the ditch were a Nene Valley greyware bowl or dish which would be later than the third century (Cooper 2000, 87) and sherds from a narrow-necked jar.

The group from the pit 10086 included earlier material such as a white ware vessel, a storage jar of first to second century date, a second-century samian flake, a Dressel 20 rim of the late first to mid-second century (Fig. 15: 59), the base of a Gallic wine amphora dating to the first to third century, sherds from two Nene Valley beakers, and one rouletted sherd probably of late second to early third century date. Several wide-mouthed jars, some with the heavier bead rims, were present and these, together with the late shell-tempered wares, indicate pottery accumulation in the late third and early fourth century. The wide date range of the pottery sherds may indicate that this group had accumulated elsewhere before being dumped in a disused pit. The small group from the evaluation trench ditches 2423 and 2435 included another everted-rim jar, a body sherd from a narrow-necked jar with zones of wavy line decoration and two greyware plain-rim dishes, a type common from the late second until the fourth century.

Of the east-to-west aligned ditches towards the eastern end of the site, only ditches 10303 and 10313 contained any pottery: an undiagnostic shell-tempered sherd of uncertain date and a sherd with a zone of incised wavy lines defined by two horizontal grooves respectively. Such decorative zones can be readily paralleled in the range of narrow-necked jars common in the later third and fourth centuries (Todd 1968, fig. 2, no. 6). A sherd from pit 10036 gives a late *terminus post quem*, in the late third or early fourth century, for its infilling. Pit 10059 yielded a samian footring base dated AD 120 to 150.

Unphased, site 5

Of the five small, shallow pits in the north-eastern corner of the site, four had heat-reddening of the base or sides, evidence of *in situ* burning, although the degree of discoloration did not suggest prolonged or intense heating. Single sherds of pottery were recovered from all except pit 10259. These were mostly small, abraded and undiagnostic and could only be broadly dated as Roman, although they include a small samian sherd from the upper fill of pit 10284, which dates to the Flavian period: AD 69 to 96. However, pit 10259, which seemed to belong with the others in the group, was stratigraphically later than the phase 5 gully 10273, suggesting these features may all have been of a late date and that the samian sherd was residual in pit 10284. The shape of pit 10287 was reminiscent of an oven with a flue, but the level of heat-reddening would indicate very limited use. A soil sample from the fill of pit 10259 produced grains of barley with small quantities of wheat grain and chaff, and arable weed seeds.

There was another oven-like feature, 10012, near the southern edge of site in the field to the west of the modern hedgeline (Fig. 17). The western side of this

feature had been lost to a medieval furrow, but the edges of the cut were heat-reddened and its lower fill was an almost black ashy silt deposit. Seven abraded sherds of pottery could only be broadly dated as Roman.

A cluster of pits to the west of ditch 10084 produced very little dating evidence, but all seemed to be later than the phase 3 ditch 10043. The stratigraphic sequence indicates that these pits were in use over a prolonged period, perhaps spanning phases 4 and 5.

The features towards the western end of the site included several large ditches, smaller linear features, and a wide shallow feature, 10183, with large cobbles in its fill which may have been the remains of a trackway. The overall orientation of these features corresponds more with the phase 1 ditch 10159, suggesting that they may be pre-Roman, which might also account for their general lack of artefacts. Otherwise, the sparsity of finds would indicate that this area was relatively remote from the main focus of settlement activity and not regularly used for the disposal of waste.

CHARRED PLANT REMAINS FROM OVEN 10012: JAMES RACKHAM

The charcoal in oven 10012 indicates that the fuel probably consisted mainly of fairly narrow oak roundwood. Since charred plant remains were very sparse and there was no evidence to link iron-working with this feature, the function of the oven is uncertain, but the specific selection of oak to fuel the oven might indicate that it was used for non-domestic activities.

POTTERY, SITE 5: RUTH LEARY

The average sherd weight (11g) was lower than that for site 4 (16g) and the total weight recovered was also less. The largest assemblages came from phase 3 ditch 10066 and a large group also came from phase 5 pit 10086. Nearly 50 sherds came from trackway 10299 and from ditch 10084 but most features had less than 30 sherds. The focus for the disposal of ceramic debris lay elsewhere.

Two burnt sherds were identified: a body sherd from phase 3 ditch 10112 and an amphora sherd from phase 4 ditch 10133. A samian sherd from unphased feature 2417 had been repaired and a repair may also have been attempted on a sandy ware body sherd from ditch 10043.

Spatial analysis, functional groups and site status

Pottery was concentrated in the area of the trackway and in ditches 10084 and 10066 but little coherent patterning was detected. The pottery from the trackway may represent continuous casual losses whereas the ditch groups are more likely to be rubbish deposits in redundant features.

The relative quantity of jars increased through time. No rims were recovered from phases 1 and 2, but in phase 3 the assemblage was dominated by bowls, wide-mouthed jars and storage jars. In phase 4 the number of bowls diminished in favour of dishes, mortaria and drinking vessels such as flagons and beakers. In phase 5 jars were still more common with more narrow-necked jars, and

amphorae were present. The level of occurrence of bowls and dishes is lower than at site 4 but if beakers and flagons are included the numbers are comparable. The group lies within the range for rural sites.

The presence of several amphora types, including characteristic wine amphorae, indicates a rise in status in phases 4 and 5. The increase in samian ware reflects the same pattern. However, as the Dressel 2–4 amphora is more likely to date to the first century, the settlement must have been able to obtain luxury goods at an early date. The overall quantities of traded ware were low with only small amounts of colour-coated ware, black-burnished ware and shell-tempered ware until phase 4. A sherd of Bourne shell-tempered ware from an unphased context indicates that a different source of jars was accessed in the third century. The presence of early shell-tempered, rebated-rim jars (Fig. 15: 56, 57) on the site shows that this settlement obtained traded vessels in the late first to mid-second century in small quantities.

Pottery supply

The number of sherds from phase 2 is too small for any reliable analysis. In phase 3, some of the shell-tempered vessels may be traded but other coarse wares are likely to have been obtained locally. Kilns in the Midlands including Warwickshire and Northamptonshire have been suggested as the source for oxidised wares (Clay and Pollard 1994, 114) rather than kilns at Leicester. If this is so, it implies considerable trading networks for this rural site where 10 to 20% of the group was of this type.

Rather more traded goods arrived in phase 4: imported samian and oil amphorae; Dorset black-burnished ware; Harrold shell-tempered ware; Nene Valley colour-coated ware and greyware; Mancetter-Hartshill mortaria and perhaps a Lincoln mortarium; and white wares, probably also from Mancetter-Hartshill kilns, Warwickshire. This indicates a wider range of trading contacts and is consistent also with the rise in status suggested during this phase.

Overall, the assemblage indicates that the site attracted trade from the first and early second century but was increasingly able to acquire goods from a greater distance in phases 4 and 5 as its fortunes rose.

ANIMAL BONE: JENNIFER WOOD

The assemblage of animal bone is consistent with a cattle-based economy. The age profiles suggest that milk production or use for traction was important, although this is less so in phase 3. The skeletal element representation suggests a predominance of butchery waste within the assemblages from most phases, as with site 4, though in the phase 4 contexts associated with the trackway the skeletal element representation suggests a slightly greater proportion of food debris. A predominance of butchery waste might imply that the excavated areas were not within the core of a settlement, but more on a periphery where messy tasks such as butchery and associated waste disposal were more likely to occur.

COINS FROM SITE 5: ROSE NICHOLSON

One of the two coins recovered from this site was a sestertius of Antoninus Pius from spread 10207 overlying ditches 10192 and 10194. This particular issue was minted in Rome between AD 140 and AD 144. On the reverse the goddess Victory advances right carrying a trophy in both hands. The other coin was not closely datable.

Discussion, site 5

There is evidence of activity on the site from the late Iron Age through to the late Roman period, although never at a level that would imply occupation on the site itself or very close to it. Most of the pottery recovered consists of small sherds, suggesting that it was contained within the plough soil, either from the spread of surface detritus or perhaps from manuring, before becoming incorporated within the fills of features. A number of features, in particular ditches 10088 and 10114 from phase 3, the phase 4 trackway and phase 5 ditches 10084 and 10194, produced modest assemblages of animal bone, probably butchery waste or domestic debris. Again, this material is likely to have derived from casual disposal of detritus at the periphery of an area of settlement together with some more deliberate dumping of waste within redundant features.

The distribution of features seems to show a bias towards the north side of the site. This could imply that the focus of settlement was on that side, although higher ground to the south might be expected to be a more favourable location.

The high level of residual finds, derived from the ploughsoil rather than primary deposition, accounts for some of the difficulties in phasing the site. The phasing scheme outlined above is reasonably secure, but, as the placing of some of the features within a particular phase has involved a degree of subjective judgement, the details may not be wholly correct.

The datable artefacts seem to show a shift in the focus of activity towards the east over time. This may have been related to hydrological changes, as the west end of the site was the lowest lying, and there was a build-up of colluvium deposited over some of the archaeological features here. A trend towards wetter conditions and a higher water table may have led to successive abandonment of the lower parts of the site.

The cobbled trackway is perhaps the most significant feature. This was probably not a long distance route; more likely the metalled surface was a response to the locally wet ground conditions either side of a crossing point on Gaddesby Brook. The track does not appear to relate to any known Roman roads. It aligns with the phase 3 and 4 ditches, and the establishment of the route may have influenced a reorientation of the field system from the alignment represented by the Iron Age ditch 10159.

Both the modern field boundary and the remnant furrows from ridge-and-furrow ploughing are also on the same alignment. This might merely reflect the pattern of land drainage, but it is quite plausible that the Roman features survived as elements of the landscape for long enough to influence the direction of medieval

ploughing, which in turn determined the orientation of the modern field boundary when the land was enclosed.

Inhumation burials within ditches seem to have been relatively common on Roman sites but examples from Leicestershire are surprisingly scarce. Their significance is not at all clear; at first sight, the practice would appear to be disrespectful, but there is often nothing in the disposition of the body to otherwise suggest this. It could be that boundaries, especially those that were of long standing, acquired a ritual significance and were favoured as burial sites because of their marginal situation.

Apart from the two oven-like features, and some evidence of burning in other pits and ditch fills, there was little to suggest that the function of the site was anything other than agricultural. A few flakes of hammerscale and small amount of slag in the magnetic component of some samples are indicative of iron-working, but on a very small scale and probably at some distance from the site.

The primary purpose of the linear features was almost certainly water management, the north-to-south aligned ditches draining the site towards the brook, while the smaller number of linear features on a perpendicular orientation would have served as feeder drains. Once established, they would also have defined land management units. The small vertebrates and snails recovered from the processed samples were typical of open grassland habitats, suggesting that the land reverted to fallow or pasture between occasional episodes of cultivation, when old drains were cleared or new ones dug.

SITE 9: ROMAN ENCLOSURE WITH STONE-LINED WELL

Rearsby Parish, NGR 464290 314285

Introduction

The most striking feature of this site was a 7m-deep, stone-lined well, located within the corner of an area enclosed by a rectilinear ditch. This ditch showed up clearly as a strong magnetic anomaly in the geophysical survey, and its presence was confirmed by evaluation trenching, which dated it to the later Roman period. The well, a system of small rectilinear ditches, two small oven-like features and several small pits were revealed when the excavation area was stripped of topsoil and a thin layer of gravel-rich subsoil. The enclosure may correspond to one of the cropmarks identified on air photographs of the area (Pickering and Hartley 1985), part of HER site LE 875, but the available locational information is not sufficiently precise to confirm this.

The site lay within a small area of farmland between the villages of East Goscote to the south and Rearsby to the north (Fig. 18). The land here slopes gently down to the south-west beyond the Leicester to Peterborough railway line to the River Wreake, 400m away.

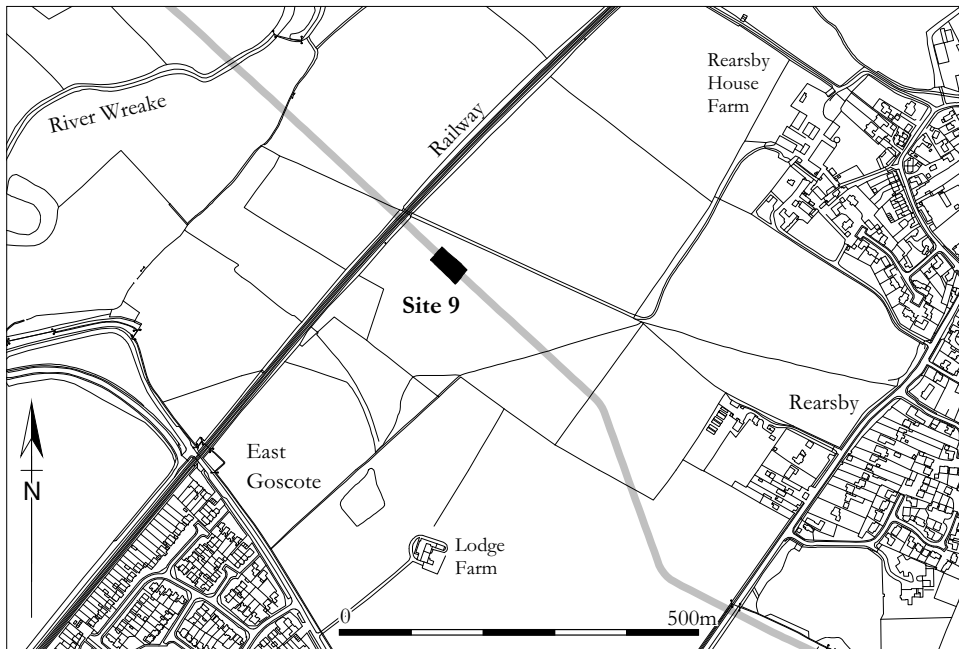

Mapping reproduced by permission of Ordnance Survey on behalf of HMSO. © Crown copyright 2008. All rights reserved. Ordnance Survey Licence number 100021059.

Fig. 18. Location of site 9.

Late first to mid-second century

Features from this phase include several small shallow gullies, typically no more than 0.60m wide; a shallow circular pit, 40075, disrupted by tree roots; and the two oven-like features in the northern corner of the excavation area (Figs 19 and 20). It is also likely that the rectilinear enclosure ditch was originally established at this time, as ditch 40103, in the centre of its southern arm, produced some of the earliest pottery from the site. This section was shallower than the rest of the enclosure ditch, and its yellowish silty fill was slightly paler than elsewhere, suggesting that this was part of a precursor ditch, left as a gap when the rest of the ditch was re-cut. Two possible terminals to the west and east of this gap were identified. Gully 40039 was recorded as stratigraphically earlier than ditch 40103, but the pottery dating suggests that this might not have been the case.

The oven-like features in the northern corner of the excavation area contained only undiagnostic Roman pottery. The more westerly of the pair, 40132, had a regular keyhole shape, with a circular body and a flue extending to the south-east. It was cut by the other feature, 40111, which was slightly larger with a less regular flue, extending in the opposite direction. A spelt grain from feature 40111 produced a radiocarbon date of 70 to 250 cal AD.

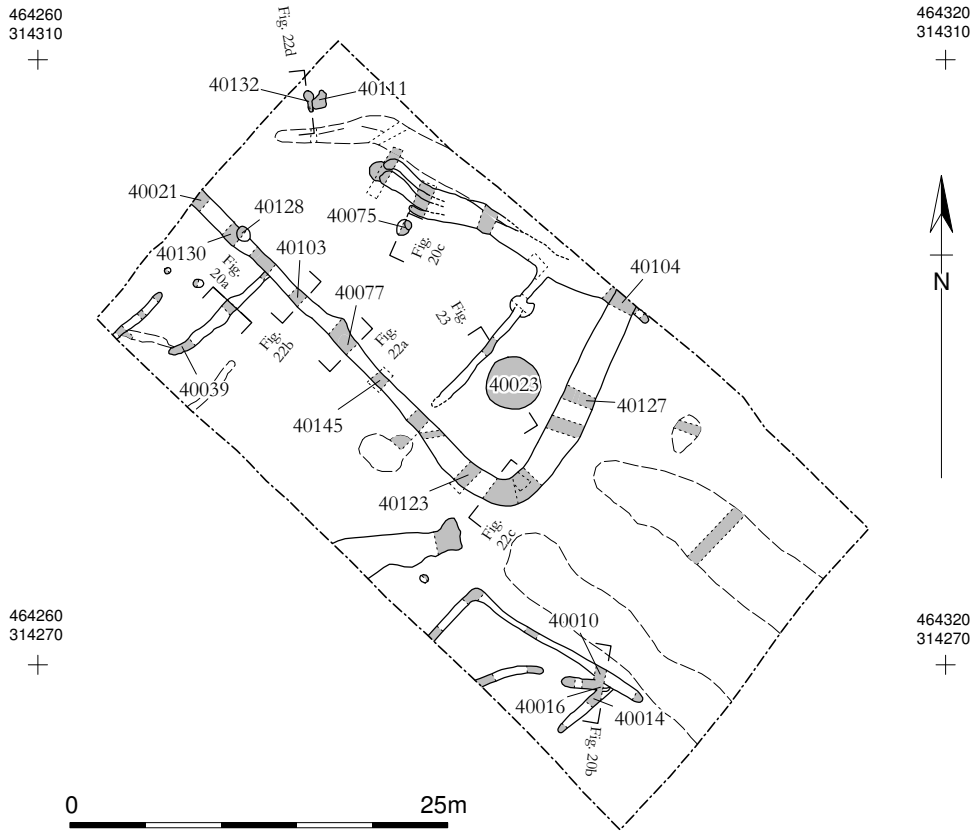

Fig. 19. Site 9, plan of all features.

The stratigraphic sequence of the features towards the southern corner of the excavation area, with gully 40010 cutting pit 40016 which in turn cut gullies 40012 and 40014, suggested an extended period of use, but the dating evidence from this group of features was sparse. The intercutting sinuous, curvilinear ditches or gullies in the north part of the excavation area were stratigraphically earlier than enclosure ditch section 40104, but were otherwise undated. This part of the site was considerably complicated by outcropping patches of reddish clay among the underlying river terrace gravels.

POTTERY FROM EARLY SITE 9 FEATURES: RUTH LEARY

Material from this phase can be dated to a period stretching from the early to the mid-second century at the shortest, or the mid- or late first to the mid-second century at the longest (Fig. 21: 60 to 64). The lack of early and transitional wares implies that the first date range is the most likely. The stratigraphic sequence indicated that features with some late first- to early second-century sherds post-dated features with mid-second-century pottery. This may simply indicate that the

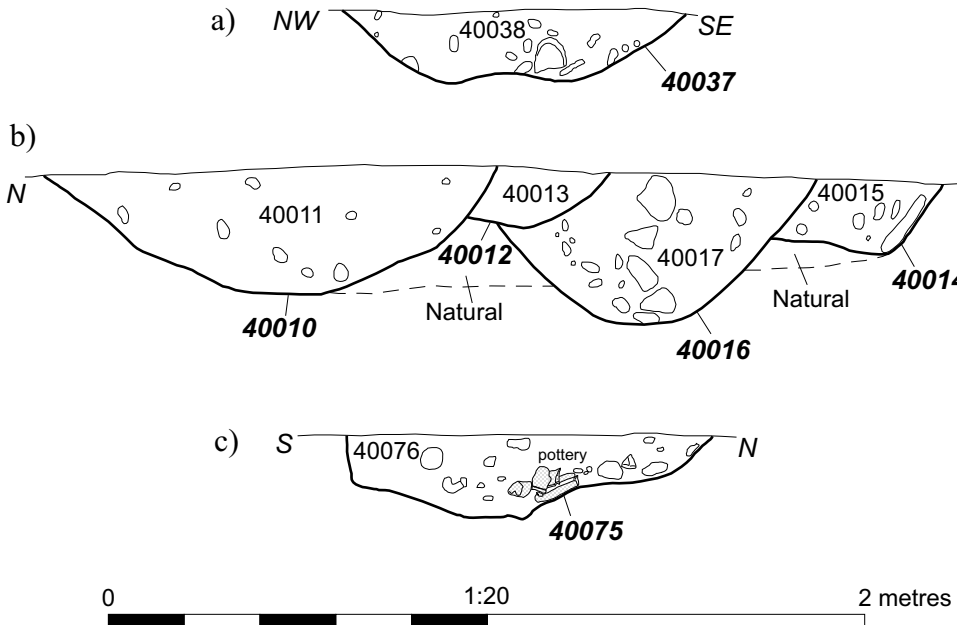

Fig. 20. Site 9 sections.

ditches were infilled at this later date but were in use during the earlier part of the second century.

Ditch 40103 contained an early shell-tempered jar and a greyware wide-mouthed jar, and a date in the late first or early second century would be likely. However, pottery from ditch 40039, an apparently earlier feature, included a samian piece dated AD 120 to 200 and two scraps from a Nene Valley colour-coated beaker of mid- or late second century date at the earliest. Samian ware from gully 40058 was given an Antonine date. The 23 sherds from pit 40075 included an early to mid-second-century black-burnished bowl, a flat-rim dish, a white ware flanged, hemispherical bowl, a samian dish, probably of Antonine date, a carinated bowl of the early second century and a samian cup of the late first to second century.

Although a small group, just under 50 sherds, the pottery from these features gives a consistent impression of activity during the early second century terminating around the mid-second century.

CHARRED PLANT REMAINS: JAMES RACKHAM

Despite the low density of botanical remains, the assemblage from pit 40075 is noteworthy for the presence of identifiable cereal grain, as well as elder and possible flax seeds, and heather stem fragments. It appears that the assemblage is domestic in character with traces of species that are likely to have been of economic value to the inhabitants.

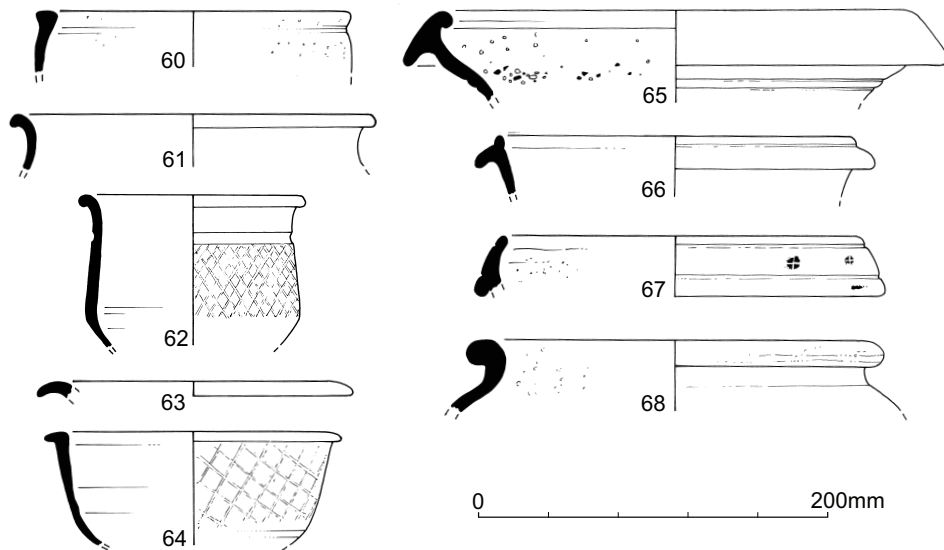

Fig. 21. Pottery site 9.

| | |
|----|---|
| 60 | Jar with rather upright triangular rim. This vessel could be pre-conquest or early Roman. Fill 40102 of ditch 40103. |
| 61 | Wide-mouthed jar. The complete form of this vessel is not known but an early Roman date in the late first or early second century would be possible. Fill 40102 of ditch 40103. |
| 62 | Much of a carinated bowl/beaker with traces of acute lattice burnish on the upper body. Fill 40076 of pit 40075. |
| 63 | Flange, probably from a flanged hemispherical bowl. Fill 40076 of pit 40075. |
| 64 | Black-burnished flat-rim dish with acute lattice burnish. Fill 40076 of pit 40075. |
| 65 | Hammerhead mortarium. A flake of this mortarium came from fill 40020 of ditch 40021 but the rest came from well fill 40088. |
| 66 | Developed bead and flange bowl. Fill 40078 of ditch 40077. |
| 67 | Hammerhead mortarium with groove at rim and distal end and traces of paint. Fill 40145 of ditch 40146. |
| 68 | Bead-rim necked jar. Fill 40131 of ditch 40130. |

Table 5. Illustrated pottery site 9.

Considering the interpretation of features 40111 and 40132, the actual quantities of charred crop remains recovered are quite small. The weed seeds identified include species that are frequently associated with disturbed or waste ground, arable land and grassland, and many are not particularly habitat specific. It is likely that many of the weed seeds are associated with the crop processing residues, although the smaller weed seeds may be derived from collecting grass for fuelling the kilns. Small numbers of sprouted grains are likely to be the residues of

natural spoilage as opposed to the deliberate germination and malting of grain for brewing purposes.

Third and fourth centuries, enclosure ditch

The rectilinear ditch 40021 was a quite substantial feature at the north-western limit of excavation and in its eastern arm, up to 2m wide and 0.85m deep (Fig. 22). A re-cut was recorded in intervention 40127 but was not seen elsewhere. Around 70% of the pottery from this feature came from a single intervention, 40123. Intervention 40104 produced a fragment of a coin, a radiate with an illegible inscription, but datable to the range AD 260 to 295.

POTTERY FROM ENCLOSURE DITCH: RUTH LEARY

The pottery from the ditch included a flake from a mortarium of late second- to third-century type from the fill of section 40021, a jar of second-century type from the fill of section 40130, a late third- or fourth-century developed bead and flanged bowl as well as sherds from narrow-mouthed jars of the same class as those from the well, developed bead and flanged bowls from section 40077 and the primary fill 40106 of section 40104, 38 sherds from a very abraded everted-rim jar, possibly second or third century, in the primary fill 40124 of section 40123, scraps of a Nene Valley colour-coated beaker from the secondary fill 40125 of section 40123, and a painted mortarium of mid-third to mid-fourth century date from fill 40146 of section 40145 (Fig. 21: 65 to 68).

These types would be consistent with continuing, though very tidy, occupation, in the second century, and certainly with occupation in the late third to early fourth centuries. The amount of pottery is small, just under a hundred sherds, nearly half of which were from a fragmented jar in section 40123. This scarcity of pottery suggests this may have been part of a domestic enclosure kept clean of debris. Its location next to a well would be in keeping with this, since one might expect domestic debris to be deposited away from the water supply to prevent spoiling.

The well

A circular cut, 3.5m in diameter and funnel-shaped in profile, contained a carefully constructed stone-lined circular shaft with an internal diameter of just under 1m (Fig. 23). The stones were large river-worn cobbles with occasional re-used pieces of quern and worked masonry. The upper part of the cut, to a depth of 2.6m, had been backfilled with clay behind the stone lining. Below that depth, a rubble fill had been used in place of the clay for a further 2.7m. From this point down, the steening backed directly onto the bedrock. The lowest part of the shaft, 0.80m above its base, was unlined. The whole well was just under 7m deep.

The fills of the well could be grouped into three broad layers. The upper fills consisted largely of river-worn stones similar to those used in construction of the lining, but there were also two pieces of worked stone: one was a crudely shaped

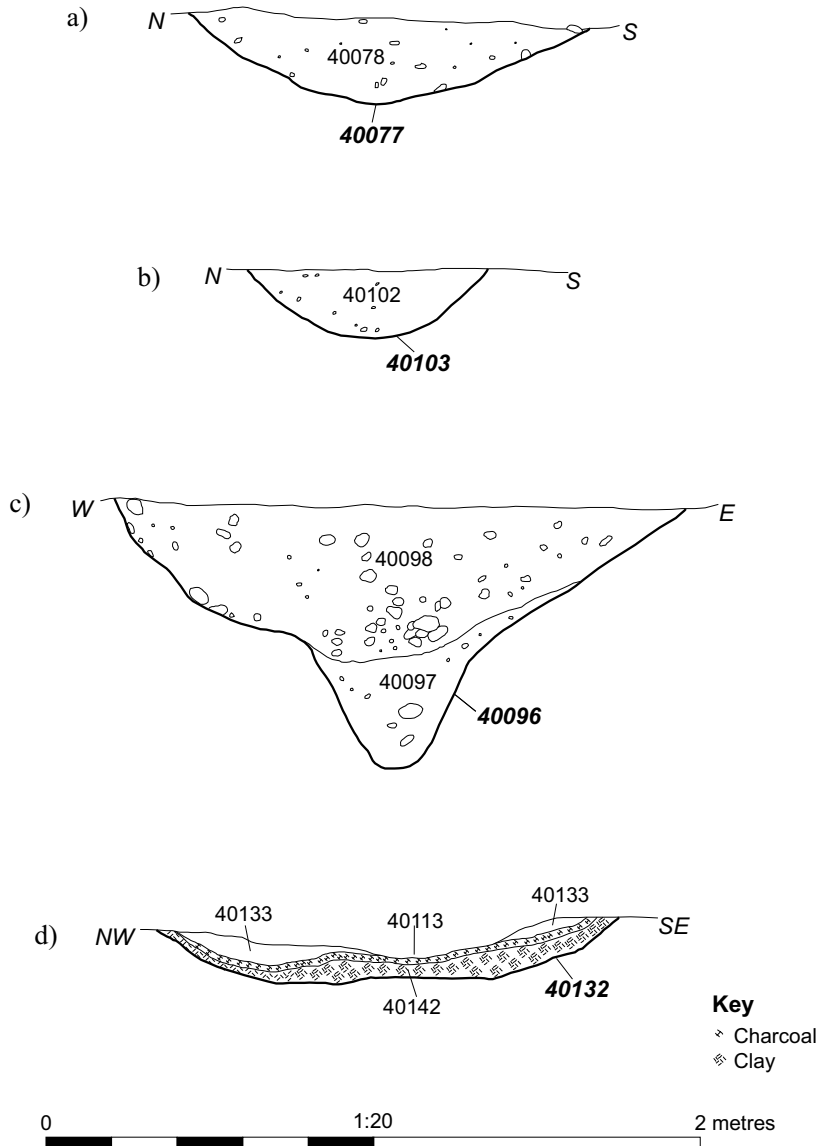

Fig. 22. Site 9, sections through enclosure ditch (a–c) and oven 40132 (d).

sandstone boulder with a hole through the middle, which may have been used as a door pivot stone or possibly as a crude weight (Fig. 24: 69); the other was probably a piece of coarse building stone, but may have started life as a millstone. Beneath these rubble deposits, a layer of dark waterlogged organic silts contained a considerable quantity of preserved wood. This seems to be mostly waste from working of small timbers or coppice wood, deliberately dumped rather than, say, the remains of a timber structure over the well. The primary fills were gravels,

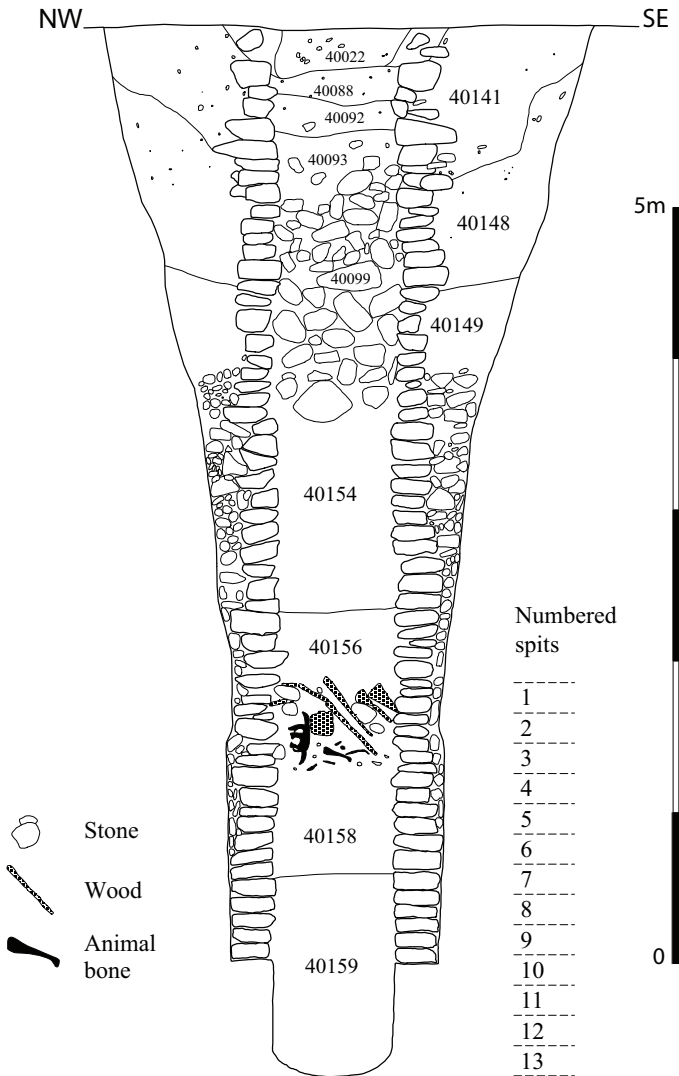

Fig. 23. Section through well 40023.

sands and silts. Three complete narrow-necked greyware pottery vessels and a metal jug, probably of pewter, were recovered from the lower fills. Other finds from the lower fill of the well included six coins, one being closely datable to AD 293 to 296, a socketed iron hook (Fig. 25) and a rotary quern fragment (Fig. 24: 70).

The well also produced a rich variety of animal bones. In addition to the usual domestic species: fox; pine marten; weasel; mole; hare; field and water vole; wood mouse; shrew; frog or toad; raven and birds of the sparrow, finch and thrush families; and freshwater fish of the tench or roach family, were all represented in

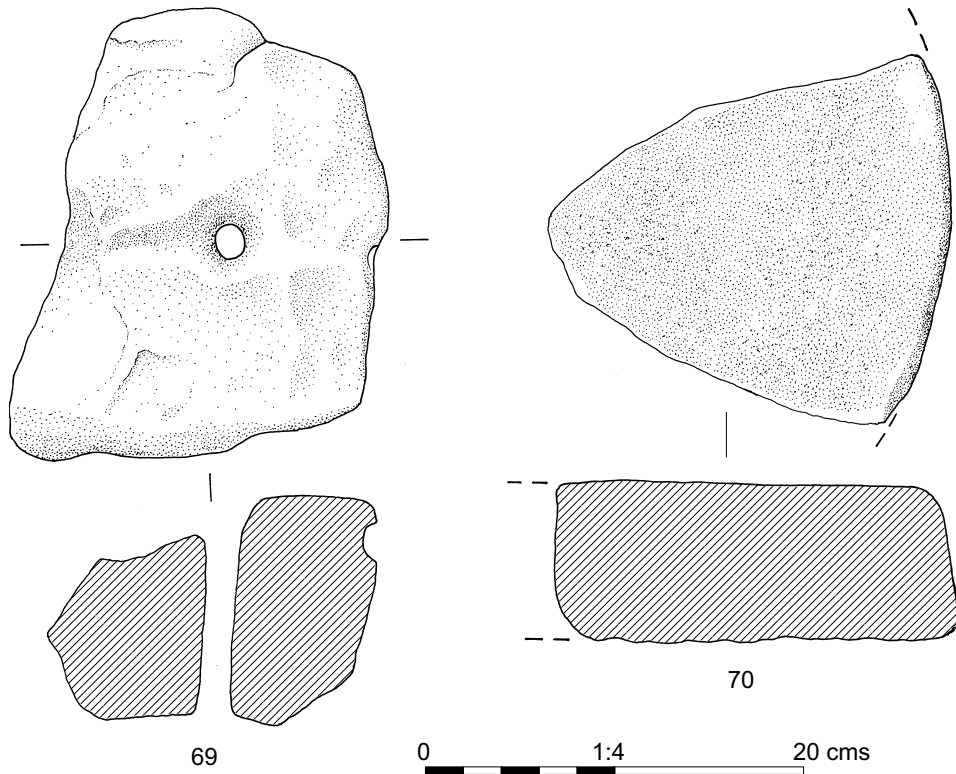

Fig. 24. Quern stones from well.

the assemblage. A number of complete carcasses were present, including at least two cattle and two sheep.

POTTERY FROM THE WELL: RUTH LEARY

Of contexts related to the construction phase of the well, fill 40148 contained a small body sherd, fill 40155 four sherds from a jar base, and fill 40147 two small body sherds bearing spaced, burnished horizontal lines similar to the ones found on the narrow-necked jars in the well infilling deposits. The decorative motif is not, however, sufficiently diagnostic to give anything more than a broad date range from the mid- or late second to fourth centuries.

The well shaft itself contained ample dating evidence including three complete pots and other pots which were broken but could be almost completely reconstructed. A large unabraded sherd from a Nene Valley beaker with narrow slit indentations from the very base of the well gives a *terminus post quem* in the fourth century for the abandonment of the well. Two sherds of this type were found in layers 40159 and 40170, probably from the same vessel. Elsewhere, these beakers declined in popularity in the mid-fourth century (Perrin 1999, 96) which would imply that the final use of the well was in the early to mid-fourth century.

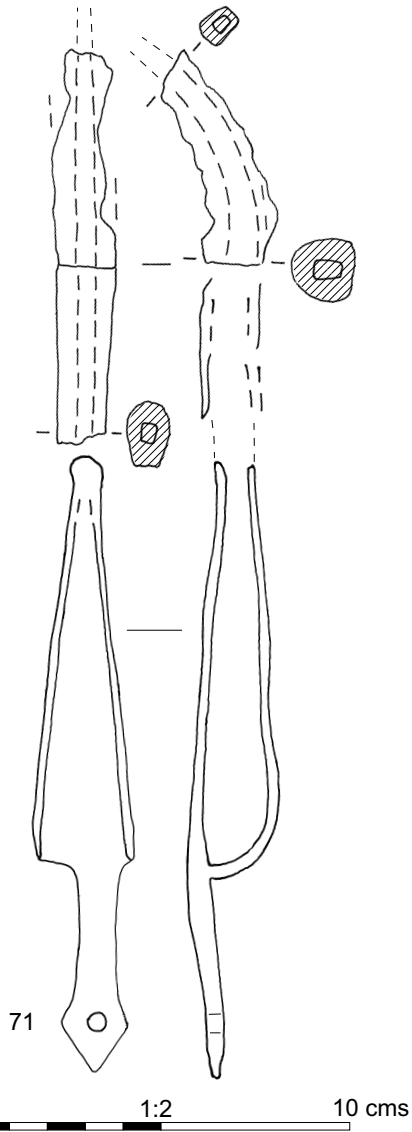

Fig. 25. Site 9, iron hook, drawn from X-ray.

Other vessels from the lowest fill include narrow-necked jars with curvilinear burnished decoration and body sherds from at least one shell-tempered vessel with rilling, of at least late third century and probably fourth century date (Fig. 26: 72 to 82).

The three complete narrow-necked jars or flasks must have landed in water or mud at the bottom of the well. Their surfaces have been badly eroded by burial conditions making reconstruction of the decoration unreliable. They are all long

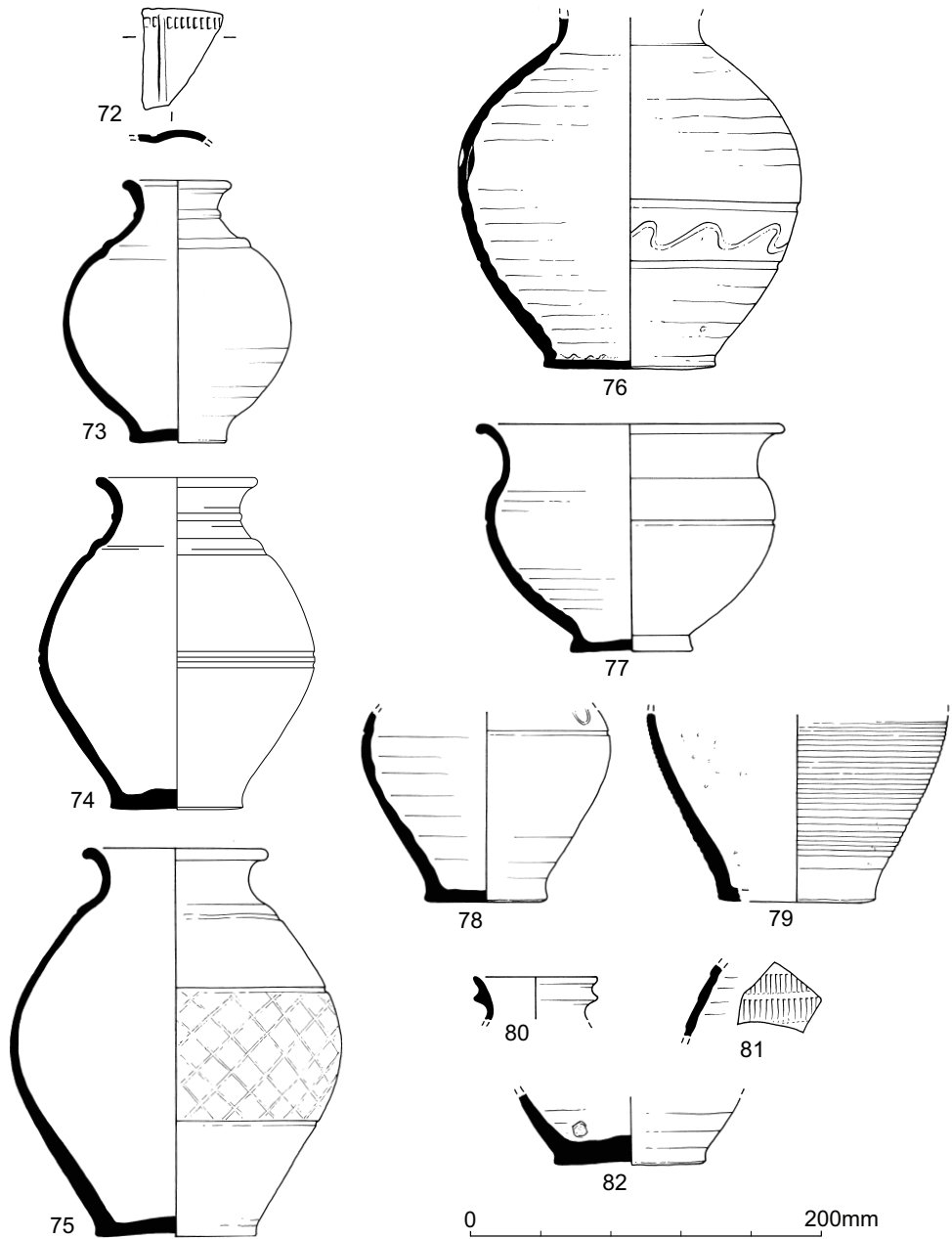

Fig. 26. Pottery from the well, site 9.

| | |
|----|--|
| 72 | Colour-coated beaker with slit and folded indentations, row of rouletting on the shoulder. Fill 40159. |
| 73 | Complete greyware narrow-necked jar with everted, internally ledged rim and cordoned neck. Surface completely eroded except around lower half of the body which has patches of darker slip. Spaced horizontal burnished lines around 1cm apart visible on the lower half of the body where surface is extant. Rim has one chip out of it. Base completely eroded but surface suggests uneven wear at one side. There are two chips around the edge of the base. Fill 40159 spit 12; small find 23. |
| 74 | Near complete narrow-mouthed jar with everted rim, single cordon around base of neck and a double groove around girth. Spaced burnished horizontal lines (around 1cm apart) visible on lower body (as above). Base worn all around edge with three small chips. On side, area of iron accretions either side of girth perhaps due to burial conditions. A sherd belonging to rim has surface and burnish intact and must have lain elsewhere where its surface was not so eroded. This suggests a highly burnished rather metallic finish. Rim is incomplete and has two large areas missing on opposite sides. Fill 40159 spit 12; small find 20. |
| 75 | Larger narrow-necked jar with everted rim and zone of acute lattice burnish around girth. Near complete with large piece missing from rim and two sherds missing around girth. The vessel is much worn around the girth with surface erosion around the upper body. Fill 40159 spit 11; small find 21. |
| 76 | Base and body of jar except rim with burnished wavy line decoration. Pre-firing dent halfway up body. Fill 40167 spit 9, joins with sherds from 40171 and 40159. |
| 77 | Much of a wide-mouthed jar with everted rim. Fill 40159. |
| 78 | Base and lower body of flask or narrow-mouthed jar with wavy line burnish around girth. Fill 40168 spit 11. |
| 79 | Rilled body sherd. Fill 40169 spit 12. |
| 80 | Small sherd from fine bifid rim from flask. Fill 40093. |
| 81 | Body sherd with zone of vertical lines, probably rouletted. Fill 40088. |
| 82 | Jar base. Fill 40158. |

Table 6. Illustrated pottery from well 40023.

lived types, but the lattice decoration on one would fit a date earlier in the general second to fourth century date range and suggests the well may have been in use throughout the occupation of the area and only fell into disuse in the fourth century.

One wide-mouthed jar from fill 40159 was burnished with a shoulder groove and fits a similar late date range of third to fourth century as the narrow-necked jars. Although less common in such features, wide-mouthed jars were also found in a well at Lound, Nottinghamshire (Leary 1995) and may have also served as vessels suitable for carrying water. Fill 40158 contained a complete jar base and a few undiagnostic sherds. The body sherds that came from fill 50156 included two from a narrow necked jar.

Fill 40154 contained more sherds from narrow-necked jars with burnished intersecting wavy lines of the type commonly found in the third to fourth centuries. A further shell-tempered rilled jar sherd would support a date in the fourth century for this while the joining Antonine samian sherds from fills 40099 and 40154 are certainly residual.

The neck of a Dressel 20 amphora was also found in the rubble-rich fill, 40099. Further neck and body sherds of a Dressel 20 amphora and sherds from narrow-necked jars, including a bifid rim comparable to one dated to the late third to fourth century, were recovered from fill 40093. Fill 40092 contained only greyware body sherds. Four vessels were represented in fill 40088: a Mancetter-Hartshill hammerhead mortarium dated to the late second to early third century, a greyware wide-mouthed jar of third- to fourth-century type, a body sherd of a Nene Valley colour-coated bowl or dish of late third to fourth century date and a samian dish.

DISCUSSION OF SITE 9 POTTERY: RUTH LEARY

Taphonomy and sherd conditions

Overall the average sherd weight, 31g, is considerably higher than at sites 4 and 5. Even when the well group, with its near complete and complete vessels, is removed it is still higher, at 25g.

Girth wear on the narrow-necked vessels from the well may be the result of being lowered down the well, as was suggested for a vessel with a cord still tied through the lug at a well at Dalton Parlours (Sumpter 1990, 244). A similar explanation was suggested for distinctive wear around the same class of vessel from the well at Lound (Leary 1995). Wear on the base could be caused by being placed on rough surfaces around the well while being filled. One vessel from the well was a second, dented in its wall before firing.

A flat-rim dish from phase 1 pit 40075 was burnt, and a mortarium sherd from secondary ditch fill 40125 of 40123 had worn trituration grits. A body sherd from fill 40154 of the well was burnt and sherds from fills 40159, 40169 and 40170 had burnt accretions.

Spatial analysis, functional groups and site status

In the earlier phase, the pottery debris was concentrated in pits 40150 and 40075, with many sherds from one vessel in the terminus of ditch 40145. In the later phase, the largest group came from the well, with nearly 50 sherds also coming from the primary fill of enclosure ditch intervention 40123.

The assemblage is thus functionally skewed, at least in the later phase. The early features had a large proportion of bowls in contrast to the well assemblage, which had very few, and the enclosure ditch which had a relatively small number. Cups and beakers were also present in the earlier phase assemblage but unlike the later groups, there were no narrow-mouthed jars. The enclosure ditch had a high representation of medium-necked jars, commonly called cooking jars, and also more mortaria, suggesting that some debris from food preparation was present in this group. The earlier phase group is domestic in character with a comparatively large proportion of bowls and table-wares, which might suggest debris from a high status settlement. However, on the basis of the vessel types, the enclosure group was consistent with a relatively modest rural site. As expected, the well group was overwhelmingly biased in favour of water-bearing vessels.

Consideration of the wares present gives a similar picture since the earlier phase includes several imported and traded wares while the enclosure group and especially the well group are predominantly local greywares. The wares and vessel types suggest that the later occupation may have been of a different and lower social order, but the distinctive functional character of the assemblage may mean that these observations are not applicable to the settlement as a whole.

The pottery from the well seems to be more than simply utilitarian. Structured deposition is well attested in prehistoric contexts (Barrett 1991; Hill 1995; Garwood *et al.* 1991) and a recent examination by Fulford (2001) of complete pots in Roman pits and wells has suggested a continuation of this phenomenon in the Roman period. Although the complete narrow-necked jars found in the silt at the bottom of the well may have been lost during use or discarded in a handy redundant shaft, the beaker sherd is less easy to explain. A small coarseware beaker might allow workers a refreshing drink at the well but a colour-coated, Nene Valley ware beaker, probably of some value, seems inappropriately fine. It would however be an eminently suitable vessel for a libation during a termination ceremony marking the end of the domestic use of the well (Merrifield 1987, 45–8). Indeed the three narrow-necked jars and the Gallic wine amphora sherds could also be linked with libations and offerings to the gods. If the complete pots which Fulford records as such a constant feature in well groups are all accidental losses then the people of Roman Britain were remarkably careless around well shafts. The loss of expensive items such as the beaker and, even more so, the lead alloy jug, hardly a vessel to be used in place of a bucket, points towards the deliberate selection of vessels for a special rite. Elsewhere Fulford suggests a link to fertility rites, or rites honouring chthonic deities made accessible through the well shaft. The material from the upper fill of the well did not include complete or near complete vessels and is more likely to be domestic in character. The complete and near complete vessels in the lower fills may result from a single event marking the disuse of the well or a time of limited duration when the well shaft took on a ritual function at the end of its useful life.

Pottery supply

The earlier phase has the most diverse assemblage. Samian accounts for 16% by sherds and 12% by weight and comes from at least five different vessels, nearly all of Antonine date. Nene Valley colour-coated wares make up 5% of this phase by sherd count and 1% by weight. Dorset black burnished (BB1) wares were relatively more common than on any other site on the pipeline, and early and late traded shell-tempered wares were present. No mortaria sherds came from this phase although white wares, often coming from the same sources as mortaria, were present. Overall the assemblage from the earlier phase suggests a prosperous rural settlement able to acquire traded goods including imports.

The Gallic amphora sherds from the well represent a new source for the site but the number of samian sherds decline. Although Nene Valley fine wares decline by sherd count, they rise by weight because the late third- to fourth-century vessels

are generally heavier than the finer beakers of the second and earlier third century. The late Harrold shell-tempered ware jars are present at a level of over 7% by weight. Although fine drinking vessels, such as the folded beaker from the well, and mortaria are present, the later settlement appears to have depended more on local wares rather than traded goods.

THE PEWTER JUG: HILARY MAJOR WITH ANALYSIS AND METALLOGRAPHY BY
PETER NORTHOVER

The body of this small squat jug was cast in one, with a single attached handle (Fig. 27). The rim and top of the neck are very corroded and somewhat distorted, and it is unclear whether there was a spout. The stub of the handle is still attached below the rim; the rest is broken off and separate. The scar where the foot of the handle was attached is visible on the body, as well as a 'shadow' where the handle was squashed against the body after burial. The top of the foot may have had a groove across it, but this is now mostly obscured by corrosion. The body is partly in good condition, with a light brown patina, glossy in places. About half is covered in lead corrosion products. The bottom of the integral foot ring has slight damage, and is unpatinated, possibly due to having been in contact with some other substance during burial.

Most pewter vessels from Britain are open forms such as plates and bowls, although closed forms such as jugs and ewers do occur. They are, however, usually more elongated forms, and the squat shape of this jug is very unusual. The form is paralleled in a copper alloy flagon, from a burial dated to *c.* 300, at Lullingstone Villa. This has a similar strap handle, but has an applied base and a cap (Meates 1987, 83). A third century date for the jug would seem appropriate.

The composition of samples taken from the rim of the jug and from the handle are so similar that they must have been cast from the same alloy melt, consisting of tin alloyed with 11.5–12% lead. Other metallic elements were at or close to their limits of detection: 0.02–0.03% copper, 0.02% zinc and 0.02% bismuth. Silicon was also detected and may come from corrosion products or grinding debris trapped in the soft metal.

Many comparative analyses are available for the tin and lead contents of Roman pewter (Gowland 1898; Smythe 1937; Pollard 1983). Of two bowls analysed from Abercynafon, Powys (Earwood, Cool and Northover 2001) one had a ratio of 89.25% tin, very close to the jug analysed here.

The sample from the rim is deeply penetrated by corrosion, and the lead distribution is well defined. Many of these inclusions are deformed or elongated, showing how the rim was worked during the final shaping of the jug. In the sample from the handle, the dendritic structure shows that the final shape is much closer to that as cast.

The jug in both composition and structure is a typical product of the Roman pewter industry, which was most active in the later third and fourth centuries (Beagrie 1989). The ritualised deposition of pewter vessels in watery locations, such as wells, rivers and marshes, is well attested; the find from Abercynafon cited above is one such example. These contexts differ markedly from the locations of

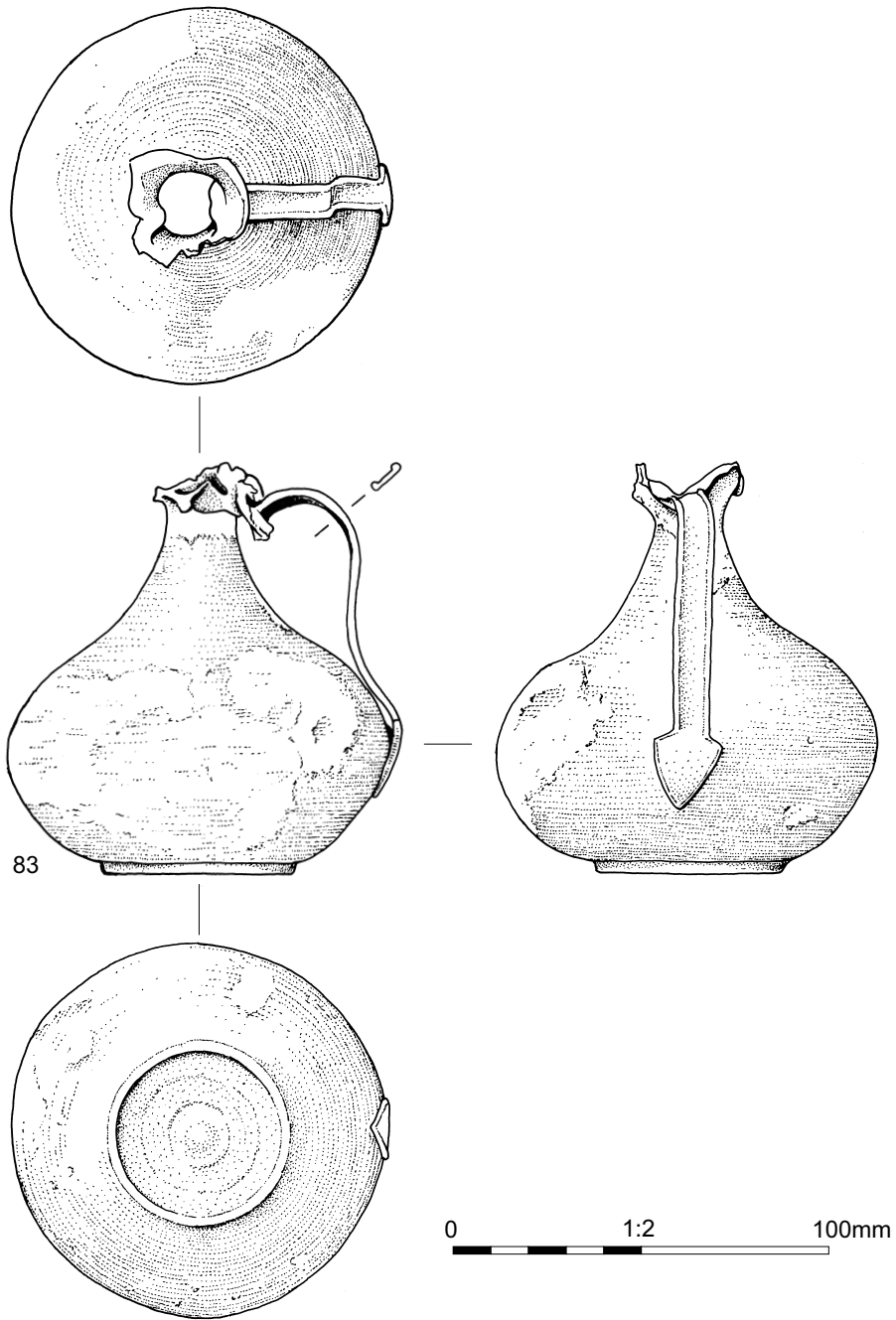

Fig. 27. Pewter jug, site 9.

Roman hoards deposited for safe keeping. Thus the context of this jug is also typical of the place of Roman pewter in the archaeological record.

WATERLOGGED WOOD: MAISIE TAYLOR

The assemblage of wood from the well is surprisingly limited in species and does not reflect the diversity of the local flora. Most of the wood is worked and was probably selected from a limited range of species, predominantly oak or ash, to suit it for various functions. None of it is derived from large material, such as forest trees, but from coppice or small trees, almost certainly growing locally. The biggest tree, or coppice, is no more than 280mm diameter and there are several between 65 and 120mm. Others are between 11 and 40mm diameter. This is within the range of diameters recommended for modern hurdle making (Forestry Commission 1956) and from known ancient hurdles or fences (Taylor 1988).

It is not clear whether some of the material is split or sawn, but splitting, especially of oak, has been a common method of reduction until recently. Before the development of modern saws it was certainly quicker and easier to split rather than saw. Most of the material appears to be general debris from domestic work such as sharpening posts or roughing out small planks, rather than from the manufacture of large structural timbers.

COINS FROM THE WELL: ROSE NICHOLSON

Six Roman coins were recovered, on only one of which it was possible to identify the emperor: a radiate of Allectus, minted in Londinium in Britain between AD 293 and AD 296. Allectus was the second Emperor of the breakaway British Empire; his coins are rare but not unexpected in Britain. One of the other coins is a sestertius of 23 BC to AD 269, the other four being third- or fourth-century radiates or nummi.

WORKED STONE: HILARY MAJOR

Of the six pieces of definite or probable worked stone recovered from the well, one was a crudely shaped sandstone boulder with a hole through the middle, which may have been used as a door pivot stone, or possibly as a crude weight (Fig. 24: 69). There were also two pieces of millstone grit, probably from querns; a sandstone rotary quern fragment apparently shaped for re-use (Fig. 24: 70); a sandstone block which had probably been utilised as coarse building stone, but may have started life as a millstone; and a probable sharpening stone fragment.

ENVIRONMENTAL ARCHAEOLOGY: JAMES RACKHAM

Context 40159, the basal fill of the well, produced a relatively low level of general debris such as wood and large animal bone, and the organic flot volumes were low. A concentration at the base of this layer of wood and organic debris, pot and a high concentration of small vertebrate skeletons, suggests that this represents a fairly extended period of accumulation during which small quantities of debris fell or were thrown into a functional well. The coarse mineral fraction, consisting of small cobbles and rounded pebbles, with occasional flint and sandstone,

accounted for a high proportion of the sample weight: up to 72%. Some of this will have washed from the clays at the base of the well while some may have eroded from the gravel deposits above during construction, but much must have fallen in from the wellhead. It is perhaps possible that gravel was intentionally dumped into the well to reduce the level of silt disturbance that might be caused by dropping in a bucket when water was drawn. The highest concentration of small vertebrate individuals was found in the basal sample and the sample immediately above; numbers fall off above this except for spits 8 and 9. Small vertebrate densities are significantly higher in context 40159 and the lower two spits of 40158 than the deposits above. Since we can probably assume that the wellhead was protected while in use this concentration, along with the low incidence of large debris, suggests that these lower fills represent steady accumulation over a fairly long period of time.

The cessation of use of the well is indicated by a marked increase in organic material, wood and animal carcasses. Remains of the skeletons of a chicken and a lamb were found in the lowest fill along with the bones of a calf's foot. These may have sunk down into the gravelly silts of this layer, as the bulk of the larger animal skeletons including a calf carcass and two juvenile sheep skeletons were distributed through the fills above, contexts 40156 and 40158. These, along with the skeletons of three juvenile ravens, were spread across at least seven spits: over 1.5m of fill, which also contained structural wood, coppice debris, and reducing numbers of small vertebrate skeletons. The density of pottery finds was low in these layers. This all suggests a relatively rapid infilling of the well, and perhaps some settling and disturbance as the carcasses decomposed.

There is a relative absence of carrion-feeding beetle remains from these layers, even in the sample from the fill (spit 4, context 40158) associated with the calf carcass. These relatively small numbers perhaps indicate that the carcass had been thrown into the well when fresh and covered with timber debris so that it decomposed under water, inaccessible to flying beetles. The alternative possibility, that the calf and two sheep were thrown in as disarticulated skeletons, already picked clean by carrion feeders, seems very unlikely. Again, this suggests that these fills built up very quickly, possibly as a series of dumping events over just a few days or weeks. Occasional large cobbles might indicate the beginning of the collapse of a superstructure at the wellhead.

The organic debris, particularly wood, became sparse towards the top of fill 40156, with only a few robust fragments surviving in fill 40154 above, the junction between these two deposits presumably corresponding to the point below which the fills have been permanently below the water table. Interestingly there was a concentration of small vertebrates in the construction fill deposits, 40153 and 40155, at this level. Such a concentration is unlikely to have occurred during a short construction period and this might indicate that the well was dry and the vertebrates obtained access from the well shaft through gaps between the cobblestone lining after falling into an already half filled well.

There was a second calf skeleton at this level in the well. The preservation of the bone suggests it was dumped into dry deposits, but they could have weathered

after a more recent drop in water table. The bones are fairly heavily fragmented, perhaps as a result of re-deposition of the skeleton during a backfilling episode, but the layer immediately above was composed mainly of large cobbles and it is quite possible that the well was backfilled immediately after the dumping of the carcass, the bones being broken by the falling cobblestones, with further subsequent breakage after decomposition as the cobble dump settled.

Some of the lowest small vertebrate densities are found in the samples from fill 40154 and the cobble layers, 40151 and 40099, and it seems likely that this filling was very quick, the cobbles being then covered with soil (40093). Context 40093 had the highest concentration of terrestrial snails in the studied sample series, which could indicate a slow build-up as the deposits below slumped, or that the fill consisted of dumped topsoil. By this stage the well would have been shallow enough for most small vertebrates to extricate themselves, and the lowest density of small vertebrates is recorded for these upper samples. Generally, these upper levels appear to have been infilled rapidly and probably intentionally, which suggests that the surrounding land was still being used and there was a need to remove the hazard of an open well.

The pollen samples from the lowest fills generally indicate that the well was surrounded by pasture and waste ground, although there is also abundant evidence for nearby ash trees, the pollen assemblage being dominated by this species. The beetle remains include an ash-feeding species, *Hylesinus oleiperda*; ash roundwood is abundant in the basal fills, along with oak heartwood and some hazel, and there is coppiced ash and ash woodchips among the worked wood fragments in the higher layers (Taylor, above). This evidence would be consistent with ash trees in a boundary hedge associated with the rectilinear enclosure ditch shedding pollen directly into the well, and fresh wood being harvested and worked nearby.

The evidence from the beetle remains supports a picture of an open grazed pasture landscape with some disturbed ground and waste places but largely free of trees, although rotten timber and dead wood are indicated by two species: *Malthius punctatus* and *Anobium punctatum*. Plant macrofossils of scrub, hedgerow and woodland environments are fairly common with hawthorn, elder, *Rubus* and *Prunus* seeds providing further indications of the likely presence of a nearby hedgerow. Gnawed hawthorn and *Prunus* stones might indicate that some of this material perhaps entered the well as a result of small mammals caching seeds and fruit in the structure at the wellhead. The next most abundant group of plant macrofossils are those typical of disturbed ground and waste places, presumably deriving from the immediate surroundings of the wellhead. Chickweeds, small nettle, stinging nettle, black nightshade and *Polygonum* species fall into this group. Pasture beyond this disturbed area would account for the few grassland plant macrofossils, such as selfheal, sheep's sorrel and buttercups, and would also explain preponderance of grassland species among the pollen, beetle and small vertebrate assemblages, which reflect a wider area than the plant macrofossils.

The possibility that the pollen and plant macrofossil assemblages in the samples from the upper fills of the well were introduced in the stomach of the cattle carcase cannot be discounted. Nevertheless the dominance of field voles, common shrews and frogs in the small vertebrate assemblages is consistent with there being an open grassland environment beyond the immediate vicinity of the wellhead. Woodmice are also present; along with bank voles, their introduction is likely to have been along the postulated nearby hedgerow. The occurrence of water voles in the primary, secondary and tertiary fills of the well, even if they represent the terrestrial morph of this species, is perhaps unusual. A possible explanation might be that they derive from owl pellets from a bird perching on a superstructure. If this was the case then the environmental implications of the small vertebrate fauna may be much broader than the immediate wellhead area.

The pollen assemblages from the fills that post-date the use phase of the well clearly indicate an open grassland environment, with dung beetles, especially in the upper sample, context 40158, providing evidence for its use as pasture. The small vertebrates are consistent with this picture but the occurrence of slow worm and snakes in these higher fills may reflect a reduction in the degree of human activity around the well once it was out of use.

The fills of the well also provide, indirectly, information on the local economy. Traces of cereal and possible arable weeds indicate some cultivation in the area. Cattle, sheep, pig, horse and chicken bones all indicate animal husbandry on the site, with the neonates and juvenile sheep and cattle indicating that stock was bred on this farmstead. There is no clue among the bones as to why these animals had died, although one of the sheep may have died while carrying a lamb. All the skeletons derive from juvenile animals which appear not to have been exploited except perhaps for their skins.

Exploitation of wild fruits is perhaps suggested by the uncharred seeds of elder, bramble or raspberry, sloe, plum or bullace and wild cherry, but these could all derive from local hedgerows, and the gnawing of several hawthorn seeds and occasional fruit stones would suggest such an origin. One beetle, the red legged ham beetle, *Necrobia rufipes*, is of significance because it is associated with dried meat or fish. As apparently a recent introduction to this country, its occurrence in the well is unexpected and an association with imported food such as garum fish sauce, perhaps in one of the amphorae represented by sherds in the well, might be evidence for long-distance trade items arriving at the site.

The skeletons of three juvenile ravens could easily be construed as a ritual deposit, but equally such birds may have been viewed with disfavour by shepherds and been persecuted and discarded with the other carcasses, or may even have, in their immaturity, entered the well to scavenge one of the carcasses and been unable to fly out. The carcasses and their context seem to be associated with the abandonment of the well, and its final backfilling, and perhaps therefore unlikely to have had any ritual significance.

Discussion, site 9

Taken together, these remains must represent the corner of an area of occupation extending to the north and west of the pipeline easement, and in use from possibly the late first century AD to the middle of the fourth century. This was a moderately prosperous settlement, at least in its early days, having access to imported pottery. The occupation area was enclosed by a rectilinear ditch with rounded corners; this seems to have been established at an early stage but was maintained and enlarged, so that over most of its length only the later re-cut survived.

The pair of small oven-like features in the north corner of the excavation probably date to an early stage in the development of the site. They were most likely used for food preparation on a relatively small, domestic scale.

The well

The well was in use for, at most, around 200 years and possibly much less. The pottery incorporated within its structure and in the backfill behind the stone lining indicates that it could not have been constructed before the mid-second century. The complete pottery vessels recovered from the lowest fills are not closely datable, but a second or early third century date is most likely. This would imply that they were dropped into the well quite early in its period of use. However, the pewter jug and other pottery sherds in the base of the well suggest a later date, probably into the fourth century. In the mud layers in the bottom of a well, the depth of finds need not reflect the sequence of deposition, as weight and shape will affect how far an object sinks, so disparate dates for finds in close physical association are not inconsistent. The later finds from the lowest layers of the well are not discernibly different in date from the finds from the upper fills of the shaft; the final infilling of the well seems to have happened over a very short period in the mid-fourth century.

Twenty-first century health and safety standards required the deep excavation of the well to take place within an elaborately shored shaft. This allowed a running section to be recorded not just through the fills of the well, but also through the lining and the profile of the original cut. This revealed the well-developed weathering cone at the top of the shaft and the rubble packing behind the lining. This, together with the lack of any mortaring between the stones, implies that the well was dug to its full depth before the stone lining was constructed, from the base upwards. Once beneath the surface drift deposits, the clay bedrock was presumably sufficiently stable to allow the near vertical-sided shaft to be excavated but then required the stone lining to prevent erosion and plastic deformation of its sides. The dimensions and profile are similar to many other Roman wells and shafts excavated elsewhere, both stone lined (e.g. Cooper 2000, 11) and unlined (Potter and Trow 1988, 12–16; Wrathmell and Nicholson 1990, 196; Niblett 1999, 83–9).

The complete vessels may have been used to draw water and slipped their ropes, or could have been knocked off the rim of the well while waiting to be

filled. Although the wear on the necks of the vessels lends weight to the first suggestion, it seems unlikely that vessels this small would have been used for drawing and carrying water, the smallest having a capacity of only 850 millilitres. For these vessels, and certainly for the fine wares and the pewter jug, deliberate deposition could be a more plausible explanation than accidental loss.

Deep wells exert a strong influence on the human imagination and have a long and continuing association with supernatural beliefs and superstitions. It is highly probable that at least some of the artefacts retrieved from the well were dropped in to it as part of a ritual act. This could have been a single termination ceremony before the well was abandoned, as much of the material from the lower fills is consistent with a fourth century date, rather than a periodic occurrence while the well was in use.

The infilling of the shaft of the well may have been part of the same ritual, in which case the contents, especially the complete animal carcasses, may have had symbolic significance. The deliberate backfilling could, however, have other explanations: once it ceases to be of use, the shaft would have been a convenient dumping place for rubbish, including morkin carcasses and timber off-cuts. Backfilling would also have served as a safety measure, preventing accidental falls by livestock. The incorporation of waste timber within the fills is perhaps surprising as this might be expected to have been a valuable fuel. However, waste timber has been noted in the backfill of excavated Roman wells elsewhere in the country (e.g. Alvey 1968). Perhaps, once other activity at the site ceased, the effort of transporting it to a new area of settlement was not worthwhile. The rubble in the upper fills probably derives from a superstructure around the top of the well.

If the infill of the well happened fairly rapidly, as appears to be the case, it is perhaps not surprising that the surrounding area seems to have remained as grassland throughout the process, but this indicates that agrarian activity continued after the apparent abandonment of the site.

This well has produced some interesting records of the local fauna at the time of its backfilling. The young ravens indicate the species breeding locally; the record of harvest mouse is unusual; the amphibian and reptile remains show the presence of great crested newt, slow worm, grass snake and adder; and the red legged ham beetle is a new archaeological record for this species in the country.

CONCLUSIONS

The development of activity in the late Iron Age and through the Roman period, especially in the lower lying valley bottoms, is demonstrated by these three sites. Sites 4 and 5 were both exploited in the late Iron Age and in the Roman period. In the case of site 4 at least, this activity appeared to continue through the conquest period. Fluctuations in the quantities of artefacts over time can be seen in all three of these sites, but there seems to have been a large overlap in their periods of activity. Sites 4 and 5 especially, but also site 9 and Rearsby Bypass site 6 (Clarke 2007), would have been close enough together to have contributed to the immediate economic and social neighbourhood of one another. The density of

these sites suggests that the low-lying land either side of Gaddesby Brook, and presumably the other tributary streams of the Wreake, were intensively exploited during the period, the construction of drainage ditches perhaps allowing previously less productive land to be brought into cultivation.

The artefact assemblages yield information on the economic and social relationship of Roman Leicester with its rural hinterland. The pottery assemblage seems to be a subset of the range of pottery available in Leicester, implying both close trading contacts with the urban centre but also distinct differences. This may be because certain goods were not available on rural sites or because the inhabitants preferentially used locally produced vessels, or the product that they contained. Some traded pottery types, such as white wares, seem to have been in ready supply while samian and black-burnished wares were being acquired only in small quantities. This may be a function of the relative status of these rural sites, or simply indicate that these products were in relatively short supply and that the demand at Leicester was met at the expense of the inhabitants of the surrounding rural settlements.

This contrasts with sites surrounding other settlements in the Midlands. A first century rural site near Margidunum at Gedling, Nottingham, was able to obtain Roman vessels, including samian, very early in the Roman period, and the settlement outside Derby at Ockbrook was similarly well supplied (Leary 2001, 116). The difference may reflect the fluctuations in the status of the settlements or may be the result of inherent biases within the assemblages caused by changes in rubbish disposal patterns at the settlements over time.

Wells on Roman sites are relatively common, but complete excavation is unusual and the site 9 well provides a useful comparative example for others elsewhere in the country. The evidence for possible structured deposition, while open to alternative interpretations, adds to similar evidence from other well deposits.

Small rural Iron Age and Roman sites such as the three described here are commonly found during archaeological investigations on infrastructure projects such as pipelines. The steady accumulation of information that the archaeological investigations on such projects is supplying is increasingly being recognised for its potential for understanding the large-scale patterns of landscape development in these periods, and the Ashby Folville to Thurcaston pipeline has provided a valuable insight into Iron Age and Roman Leicestershire.

REFERENCES

- Alvey, R. C., 1968 'A Roman well at Bunny, Nottinghamshire', *Transactions of the Thoroton Society of Nottinghamshire* 71, 5–10.
- Barrett, J., 1991 'Towards an archaeology of ritual', in Garwood *et al.* (eds) 1991, 1–9.
- Beagrie, N., 1989 'The Romano-British pewter industry', *Britannia* 20, 169–91.
- Brown, A. E., 1994 A Romano-British shell-gritted pottery and tile manufacturing site at Harrold, Bedfordshire, *Bedfordshire Archaeological Journal* 21, 19–107.

- Clark, R., 1999 'The Roman Pottery', in Connor, A. and Buckley, R. (eds) 1999, 95–164.
- Clarke, S., 2007 *A607 Rearsby Bypass Leicestershire excavation report*, unpublished client report for Leicestershire County Council, ULAS report no. 2007-057.
- Clay, P. and Pollard, R., 1994 *Iron Age and Roman occupation in the West Bridge area, Leicester: Excavations 1962–1971*, Leicester Museums Arts and Records Service.
- Collis, J. R., 1973 'Burials with weapons in Iron Age Britain', *Germania* 51, 121–33.
- Connor, A. and Buckley, R., 1999 *Roman and medieval occupation in Causeway Lane, Leicester*, Leicester Archaeology Monograph 5.
- Cool, H. E. M., 2006 *Eating and Drinking in Roman Britain*, C.U.P.
- Cooper, N. J., 2000 *The Archaeology of Rutland Water*, Leicester Archaeology Monographs no. 6.
- Cowgill, J., 2005 *Report on the slag and associated finds from the excavations along the Ashby Folville to Thurcaston Gas Pipeline*, unpublished assessment report for Network Archaeology Limited.
- Earwood, C., Cool, H. E. M. and Northover, J. P., 2001 'Two pewter bowls from a mire in south Wales', *Britannia* 32, 279–85.
- Evans, J., 1993 'Pottery function and finewares in the Roman north', *Journal of Roman Pottery Studies* 6, 95–119.
- Evans, J., 2001 'Material approaches to the identification of different Romano-British site types', in James, S. and Millett, M. *Britons and Romans: advancing an archaeological agenda*, 26–35, Council for British Archaeology Research Report 125.
- Forestry Commission, 1956 *Utilisation of hazel coppice*, Bulletin 27, 33.
- Fulford, M., 2001 'Links with the past: pervasive "ritual" behaviour in Roman Britain' *Britannia* 32, 199–218.
- Garwood, P., Jennings, D., Skeates, R. and Toms, J. (eds), 1991 *Sacred and Profane: Proceedings of a Conference on Archaeology, Ritual and Religion, Oxford 1989*, Oxford Univ. Cttee Arch Monograph 32, Oxford.
- Gillam, J. P., 1971 *Types of Roman Coarse Pottery Vessels in Northern Britain*, 3rd edition, Newcastle.
- Gillam, J. P., 1976 'Coarse fumed ware in northern Britain and beyond', *Glasgow Archaeol. J.* 4, 57–89.
- Gowland, W., 1898 'Analysis of metal vessels found at Appleshaw, Hants, and some other specimens of Roman pewter', *Archaeologia* 56(1), 13–20.
- Hill, J. D., 1995 *Ritual and rubbish in the Iron Age of Wessex: a study of the formation of a specific archaeological record*, B. A. R. Brit. Ser. 242, Oxford.
- Holst, M., 2005 *Osteological analysis: Ashby Folville to Thurcaston gas pipeline Leicestershire*, unpublished report by York Osteoarchaeology Ltd, report no. 2105.

- Leary, R. S., 1995 'The Romano-British pottery', in Garton, D. and Salisbury, C. R. (eds) 'Excavations of Romano-British wood-lined well at Wild Goose Cottage, Lound, Nottinghamshire', *Transactions of Thoroton Society, Nottinghamshire* 99, 15–43.
- Leary, R. S., 2001 'Romano-British pottery', in Palfreyman, A. (eds) *Report on the excavations of a Romano-British aisled building at Little Hay Grange farm, Ockbrook, Derbyshire 1994–97*, Derbyshire Archaeological Journal 121, 95–130.
- Leary, R. S., forthcoming 'The Romano-British pottery', in Brown, F., Boyle, A., Howard-Davis, C. H. and Lupton, A. (eds) *A road through time: archaeological investigations along the route of the A1(M) Darrington to Dishforth Road Scheme*.
- Leary, R. S., in prep. 'The Romano-British pottery from excavations at the Grand Arcade, Wigan', for Oxford Archaeology North.
- Leary, R. S., unpublished *Report on the pottery from excavations at Wymondham villa, Leicestershire*, for Nottingham University.
- MacGregor, M., 1962 'The Early Iron Age metalwork hoard from Stanwick, N. R. Yorks', *Proc. Prehist. Soc.* XXVIII, 17–57.
- Meates, G. W., 1987 *The Lullingstone Roman Villa: Vol II: the Wall Paintings and Finds*, Kent Archaeol. Soc.
- Merrifield, R., 1987 *The Archaeology of Ritual and Magic*, London.
- Moore, R., 2008 'Ashby Folville to Thurcaston: the archaeology of a Leicestershire pipeline (part 1: the prehistoric sites)', *Trans. Leicestershire Archaeol. and Hist. Soc.* 82, 1–38.
- NAL, 2004 *Proposed Ashby Folville to Thurcaston 450mm dia. gas pipeline: archaeological field survey report*, Network Archaeology Ltd, client report no. 502.
- NAL, 2005 *Ashby Folville to Thurcaston gas pipeline: archaeological evaluations December 2004 and February 2005*, Network Archaeology Ltd, client reports nos 503 and 513.
- NAL, 2006 *Ashby Folville to Thurcaston natural gas pipeline: Archaeological excavations and watching brief, post-excavation assessment of potential for analysis and updated project design*. Network Archaeology Ltd, client report no. 517.
- Niblett, R., 1999 *The excavation of a ceremonial site at Folly Lane, Verulamium*. Britannia Monograph Series no. 14.
- Perrin, J. R., 1999 'Roman Pottery from excavations at and near to the Roman small town of Durobrivae, Water Newton, Cambridgeshire, 1956–58', *Journal of Roman Pottery Studies* vol. 8.
- Pickering, J. and Hartley, R. F., 1985 *Past worlds in a landscape*, Leicester Museums publication 70.
- Pollard, A. M., 1983 'X-ray fluorescence analysis of the Appleford hoard of Roman pewter', *Historical Metallurgy* 17(2), 83–90.
- Potter, T. W. and Trow, S. D., 1988 'Puckeridge-Braughing, Hertfordshire. The Ermine Street excavations 1971–72', *Hertfordshire Archaeology* 10, 1–16.
- Smythe, J. A., 1937 'Notes on ancient and Roman tin and its alloys with lead', *Transactions of the Newcomen Society* 18, 255–66.
- Sumpter, A. B., 1990 'The Roman Pottery', in Wrathmell and Nicholson 1990, 135–46 and 235–45.

- Taylor, M., 1988 'The exploitation of wetlands', in Murphy, P. and French, C. (eds) *B.A.R.* 186, 88.
- Todd, M., 1968 'The commoner Late Roman coarse wares of the East Midlands', *Antiquaries Journal* 48, 192–209.
- Webster, G. and Booth, N., 1947 The excavations of a Romano-British pottery kiln at Swanpool, Lincoln, *Antiquaries Journal* 27, 61–79.
- Wild, J. P., 1970 'Button-and-loop fasteners in the Roman provinces', *Britannia* I, 137–55.
- Wrathmell, S. and Nicholson, A., 1990 *Dalton Parlours Iron Age settlement and Roman villa*, West Yorkshire Archaeology Service.

ACKNOWLEDGEMENTS

We would like to thank, once again, everyone who contributed to the successful outcome of this project. Details are listed in the first part of this article (Moore 2008).