

A ROMANO-BRITISH CREMATION BURIAL FROM WELLWICK FARM, WENDOVER

R.J. ZEEPVAT

WITH CONTRIBUTIONS FROM H PENGELLY, J. RACKHAM, S. SMITH
AND C. WOODFIELD

In 2000 a Roman cremation burial discovered by metal detectorists at Wellwick Farm, Wendover, was excavated. The cremation ashes had been placed within a flagon, which was accompanied by a range of grave goods including an adze-hammer, a lead lamp, two glass vessels and eight ceramic vessels, both samian and coarse wares. Evidence of food offerings was found in some of the latter. The whole assemblage had been interred within a wooden box. From the ceramic evidence, the burial appeared to date from the latter half of the second century AD. It is suggested that the adze-hammer may indicate the burial is of some kind of wood worker.

In late August 2000, a possible Roman cremation burial was discovered in a field adjacent to Wellwick Farm, Wendover (NGR SP 854 078). The discovery was made during a metal detecting rally organised by the Weekend Wanderers Metal Detector Society. The finder reported it to the County Archaeology Service, who promptly commissioned excavation of the burial, with funding provided by the County Archaeology Advisory Committee. Archaeological Services & Consultancy Ltd (ASC) undertook the excavation in early September 2000. An initial report was prepared shortly after the excavation (Fell 2000).

The burial site is located in an arable field about 120m east of Wellwick Farm, to the west of Wendover, at the base of the Chiltern escarpment (Fig. 1). The site is essentially flat, at an elevation of c.137m AOD. Soils in the surrounding area belong to the Wantage 1 Association (Soil Survey 1983, 342c), comprising well-drained calcareous silty soils, over argillaceous chalk.

Relatively little is known of the archaeology of the Wendover area during the Roman period, probably because the absence of large-scale modern development has limited opportunities for discovery. The *Icknield Way*, an important prehistoric trackway that probably continued in use through the Roman period, passes 1km north of the site. The Roman *Akeman Street* (latterly A41) passes 5km north-east of Wellwick Farm. This road linked *Verulamium* (St Albans) with the settlement at Fleet Marston, the nearest known occupation

centre of any size to the site, and the small town at Alchester, Oxon. Thus the area was rural and presumably given over to agriculture. Roman villas and other substantial buildings found along the foot of the Chiltern scarp at Little Kimble (Scott 1993, 27), Ellesborough (*ibid*, 26), and Branigan (1967, 131) draw attention to the suitability of this part of the Vale of Aylesbury for villa development.

Finds of Roman date in the immediate environs of the site are relatively few. In 1997, during construction of the Wendover bypass (A413), which passes 0.4km to the north-east of the site, an occupation site was located by metal detector users (*Records* 38, 258). In 1996, field walking by the County Museum Archaeology Group on land to the north recovered Romano-British pottery and some tile, indicating a possible occupation site (*Records* 37, 176).

The excavation of the burial was carried out according to a project design prepared by ASC (Zeevat 2000) and approved by the County Archaeology Service. Superficial excavation carried out by the finder when the discovery was made had revealed only the upper part of the burial, notably the top of the cremation vessel and the lead lamp, the detection of which had presumably occasioned the discovery. These finds were made at the base of the topsoil, c.200–300mm below the present ground level. The finder noted a number of other ceramic vessels but ceased further excavation at this point. The discovery was recorded in a sequence of digital photographs, subsequently

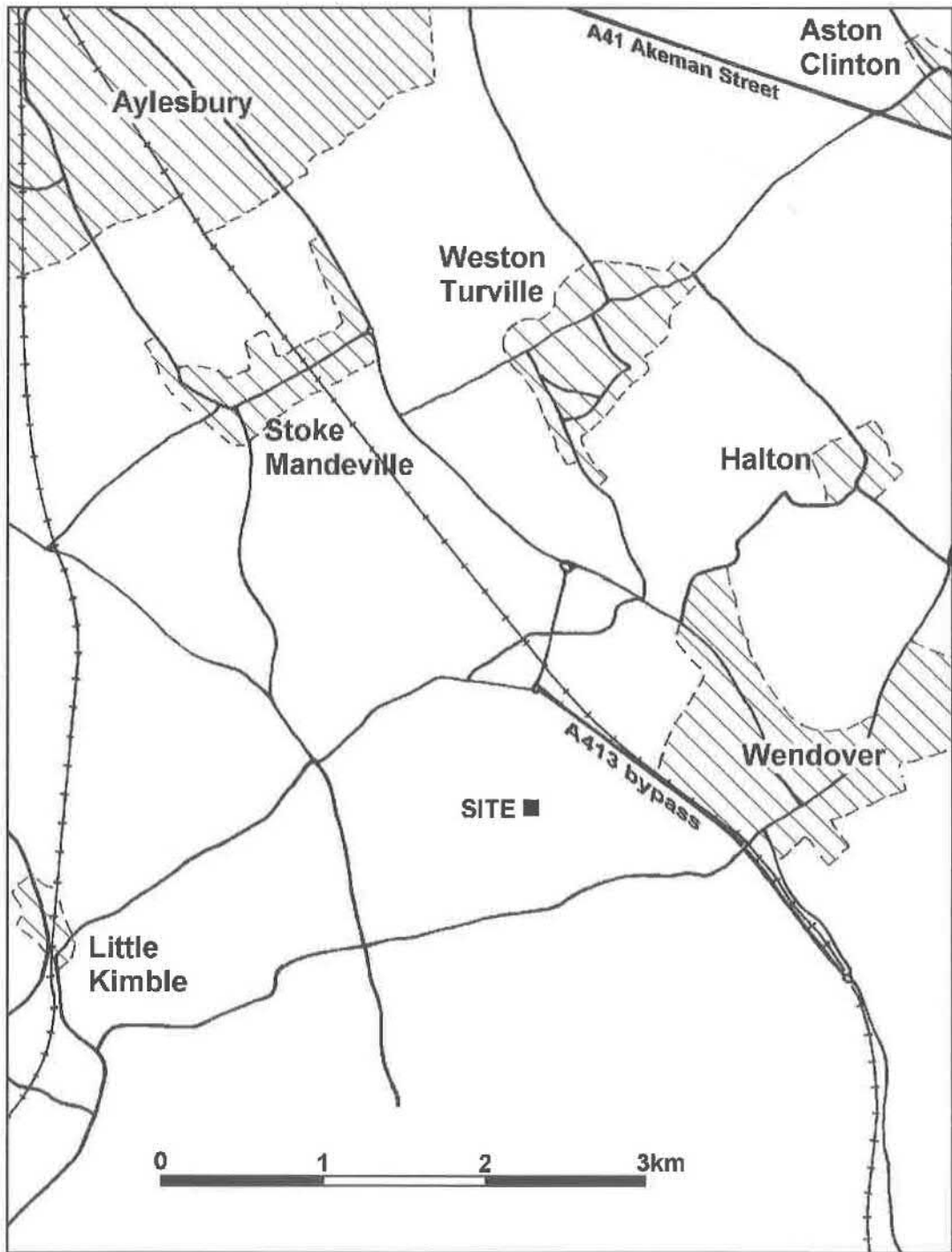

FIGURE 1 Site location plan.

made available to ASC (Plate 1). To prevent disturbance prior to detailed examination, the excavation was backfilled and a mechanical excavator parked over the site. Unfortunately, a person or persons unknown illegally removed the cremation vessel and its contents from the site before the formal excavation could begin.

The cremation burial had been interred in a pit, 0.7m square, cut about 0.4m deep into the subsoil, with a flat floor and near vertical edges (Fig. 2:

Plate 2). The pit was more or less aligned north, south, east and west. At its base, traces of a friable, very dark-brown organic deposit, probably decayed wood, remained underneath the cremation vessels (002). Iron nails (SF11–15, 17, 18) were found in the corners of the pit, both at the base and at a higher level. Taken together, this evidence strongly suggests that the burial had been placed in a wooden box or casket about 0.6m square and c.0.45m deep. A piece of iron strip

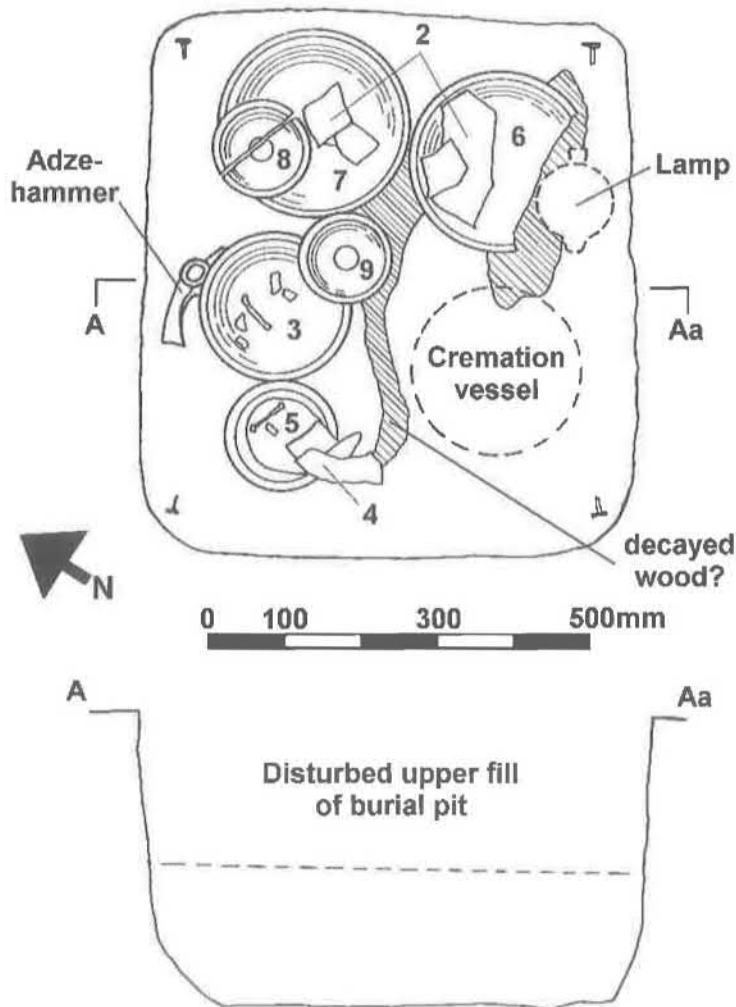

FIGURE 2 Plan and section of the burial (scale 1:10).

(SF16) may have been a fitting related to the box.

Within the box the components of the burial were arranged as follows: the cremation vessel, probably a two-handled flagon, appears to have stood in the south corner. Two large samian bowls of form 18/31-31 (Vessels 6 & 7) occupied the east and north corners respectively. On top must have been one of three identical coarse-ware 'dog bowls' present in the burial, as parts of Vessel 2 were found in Vessels 6 and 7. In Vessel 7 also was Vessel 8, the smaller of two samian cups, form 33. In the west corner was a small platter in imitation Black-Burnished ware (5): within or adjacent to it, probably disturbed by the removal of the cremation vessel, was a second 'dog bowl' (4). Towards the north-west side, between Vessels 5 & 7, was the third 'dog bowl' (3) and a large samian cup, form 46 (9). Between these two vessels and the north-west side of the box was the well-preserved head of an adze-hammer.

The original location of the lead lamp is less certain. Having been disturbed at the time of discovery it was removed for safe-keeping. From information provided by the finders, it appeared that it was close to the east corner of the burial, between the cremation vessel and SF5 (Fig. 2). However, this is uncertain. Photographs of the initial discovery show the lamp adjacent to the cremation vessel. Inside the lamp are pottery sherds that appear to have come from the cremation vessel, and have evidently been placed there by the finders. It is doubtful whether these photographs, the only record of the cremation vessel, can be used to determine the position of the lamp.

With Vessels 3, 5 and 6 were small quantities of chicken bone. These were probably food offerings, placed in the burial to sustain the deceased in the journey to the underworld.

The burial pit was filled with a deposit of firm buff-grey clay (003), similar to the surrounding topsoil. This had evidently entered after the box lid had either rotted away, or become dislodged by later ploughing. With the exception of Vessels 7 and 9 all the pottery vessels in the burial were broken, presumably by the collapse of the box, by subsequent agricultural activity, and most recently by disturbance connected with the removal of the cremation burial.

Examination of the fill of the burial pit during its removal revealed a number of small iron nails and studs and fragments of two glass vessels. One

vessel was a blue-green storage bottle, the other probably a bowl of very fine clear glass.

THE FINDS

Metalwork (Fig. 3)

1. Iron head of adze-hammer. Length 192mm. The socket is oval (dia. 25-30mm: length 42mm). Above the socket on either side are squarish lugs. The hammer head is 35mm in length, of rounded 20mm square section, and its striking face is spread with wear. The adze blade is 25mm wide at the socket, flaring to a cutting edge 62mm wide. The blade is about 100mm long, and is at an angle of *c.*50° to the horizontal. SF10.

In his excellent study of Roman ironwork, Manning (1985, 14) notes that adze-hammers are ubiquitous finds, examples having been recorded from a broad range of sites throughout the Roman period in Britain and Europe (*cf.* Kingsholm, Gloucs; Loudon Hill, Ayrshire; Bull Wharf, London; Silchester; Pompeii). He notes the existence of two basic types of tool, distinguished by the presence or absence of two lugs on either side of the eye or socket. He comments that the former, of which the Wellwick Farm tool is an example, are similar to adze-hammers found at the fort of Newstead, and may derive from military workshops. All authorities are clear that the adze-hammer is a woodworking tool: Evans (1890) identifies it as being used by a cooper: Manning (*op. cit.*) suggests it is a carpenter's tool. Both seem equally probable.

2. Lead lamp. Dia. *c.*110mm, height of bowl 24mm, overall length 144mm, exc. handle. The object is more or less circular, with a flat base and vertical sides, and a circular projection 38mm dia. for the wick. Directly opposite this a handle, max. surviving width 30mm, rises up from the side of the lamp and curls over. The handle is broken, but retains evidence for a suspension hole. No signs of burning or residues of fuel (fat, oil) were noted in the bowl. SF19.

Open lamps, usually taking the form of a shallow, straight-sided bowl with a simple nozzle, are not uncommon in iron, but are more widely found in pottery. They are often described as lamp-holders (as was the Wellwick Farm lamp initially), intended to hold a covered lamp, but there is no doubt that they are lamps

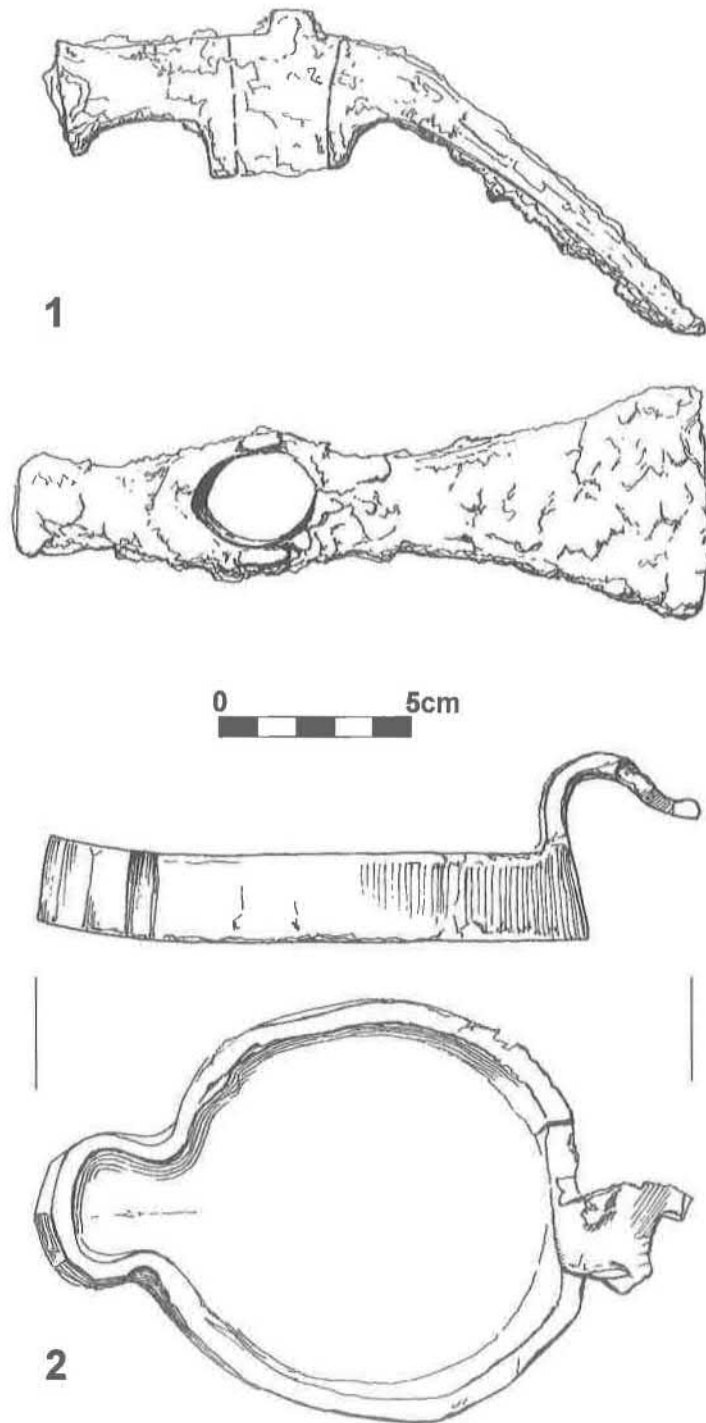

FIGURE 3 Adze-hammer (1) and lamp (2) (scale 1:2).

in their own right (Manning 1985). Manning notes that open lamps have often been found in burials of Roman date, notably in East Anglia (*cf* Baldock, Herts – two examples; Guilden Morden, Cambs; Girton, Cambs – two examples; Bartlow Hills, Essex). Open lamps of lead, though less common than pottery and iron examples, are not unknown. Bailey (1996) lists three in the British Museum collection: two from Colchester (Q3762PRB and Q3764PRB) and one from the Walbrook, London (Q3764PRB). All three are dated to the late first to second century AD. Open lamps of this type have continued in use until fairly recent times, for example the Scottish *crusie*. They were normally fuelled with fat, with a simple floating wick placed in the nozzle. Whereas closed lamps must have used oil, because of the need for a fuel that could be poured in to the reservoir, it seems likely that open lamps were more suited to a solid or semi-solid fuel.

3. Iron strip, 96mm in length, of rectangular section, 11 × 4mm. Broken at one end, possibly cut at the other. This was recovered from the undisturbed fill of the burial pit. It is too narrow and thick to be binding from the cremation box, but could possibly be some sort of fitting from it. SF16 (*not illustrated*).
4. The seven nails recovered from the corners of the burial pit (Fig. 2) all had square-section shanks and large roundish flat heads, noted by Manning (1976, 134–137) to be the most common nail type recovered from Roman sites in Britain. Surviving lengths varied, though most were *c.*40–50mm. SF11–15, 17, 18 (*not illustrated*).
5. Fifteen iron fragments, some possibly nails, were recovered from the disturbed upper fill of the pit. It is possible that some may have come from the cremation box or casket: equally, they could be of more recent date (*not illustrated*).

The Glass

Sasha Smith

6. Sixteen fragments from the body of a vessel of indeterminate form. Natural blue green glass (*not illustrated*).

Although none of the fragments have diagnostic features, such as rim or base fragment characteristics, it is probable that they are from

a mould-blown storage bottle (e.g. Isings 1957, form 50). These vessels are very common, often accounting for 30–50% of glass assemblages in this period (Price & Cottam 1998, 195). Although their primary function was storage, they are found frequently in burials, and sometimes may contain cremations. This is a particularly long-lived form, in circulation from the mid first century to the end of the second.

7. Eighty fragments from the base and body of a vessel of indeterminate form. Colourless glass (*not illustrated*).

Although most of the fragments have no diagnostic features, there are five base fragments present (four joining). The base is decorated with a relief-cut ridge. The body of the vessel was decorated with bands of oval facets that were wheel-cut into the exterior surface. It is possible that these fragments comprise a convex bowl. Distribution of these is fairly common, and they are occasionally found in burials, dating from mid to late 2nd century. (Price & Cottam 1998, 98). A local example of this type of vessel comes from Holne Chase, Milton Keynes (Price 1987, 149, fig. 48.215).

Coarse Pottery

Charmian Woodfield.

This pottery suggests a date of *c.*AD 135–155. This late date for the cremation may cause some surprise, but it should be remembered that cremations occur on Hadrian's Wall, being of Hadrianic date at Beckfoot, second and third century at South Shields, and continuing into the second half of the third century at Petty Knowes cemetery, High Rochester (pers. comm. Paul Bidwell). Therefore, in Romano-British terms this date is not unusual.

All the vessels show signs of use. The breaks look largely new, but a few appear to be old damage. The three platters (two are samian, Vessels 6 & 7, and one is an imitation Black Burnished ware, Vessel 5) and one red ware dish, Vessel 3, were apparently placed at a lower level than the other coarse ware dishes and the samian cups. The arrangement may have been food containers below, and the two cups above. The finder was aware of the presence of other vessels than the cremation vessel, and it is possible that all, except probably the three platters, had been disturbed before the archaeological excavation took place.

Catalogue (Fig. 4)

– *Unstratified*. This group of sherds comprises mostly material found at the time of discovery, and removed for safe keeping by the finders. Also included are sherds recovered from the backfill of the initial excavation. The group includes a sherd from a handled vessel, possibly the cremation vessel (see below) and 18 others, apparently from the same pot. The latter are in a fine soft pinky-buff fabric. There is little sign of sandy inclusions, but there are fairly frequent mica flakes (1.0mm+), occasional chalk inclusions up to 4.0mm in size, groups of what appear to be small (1.0mm) water-worn flint fragments, and some small red inclusions of burnt clay up to 4.0mm, usually square in shape. The outer surface of these sherds is grey in parts, apparently from burning, but whether this is a worn original surface, or the result of cremation fires, is difficult to say. Unfortunately

none of the eighteen sherds join the handled sherd. Some of the breaks are recent, but many are old. Two tiny sherds in red sandy fabrics, not from this vessel, are presumably residual from nearby occupation.

1. *The cremation vessel*. The photograph taken by Mr. Egan (Plate 1), originally in colour, shows a vessel in a pinky-buff fabric, similar to the sherds described above, and to the three red-ware dishes. The vessel rim has a diameter of c.80mm. It is necked, the neck appearing to have a height of c.45mm, and it then appears to swell out below the neck, increasing the diameter to about 160mm at the point where the base of the handle joins the vessel, c.40–50mm below the neck. The handle appears to be c.45mm wide at the top. The vessel is most likely to have been two-handed, as single handled jugs and flagons do not normally have this simple neck and rim, but are more complex in form.

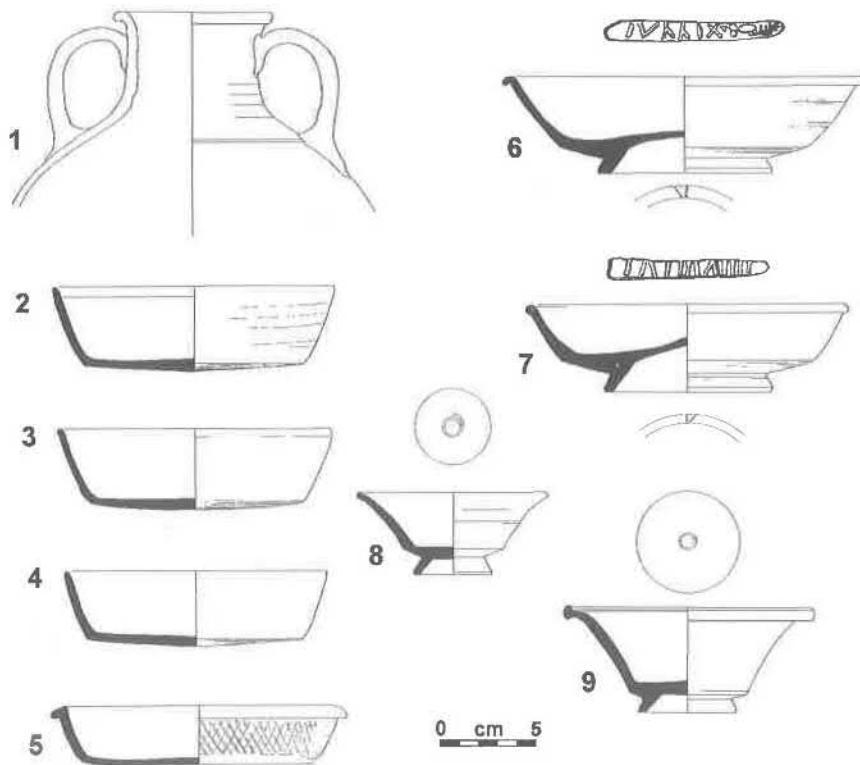

FIGURE 4 The pottery, 1–9 (scale 1:4). Samian stamps actual size.



PLATE 1 The cremation vessel, as discovered (*Paul Egan*).

Two double-handled wide-mouthed jars or flagons with similar diameters to the Wendover example are recorded at Verulamium (*Wilson in Frere 1972, fig. 116, 577 & 578*), where they are dated to AD.130–150. It is of interest that only one vessel of this form is recorded earlier than this at Verulamium. The photograph of the cremation vessel most resembles Verulamium vessel 578, as far as can be ascertained, with similar dimensions and form of rim, neck, and handle. This has been used, together with the photograph, as a basis for the reconstruction drawing.

2. *SF2/4 Red ware dish*. Rim dia. 140mm. Ten sherds (SF4), two sherds (SF2), and twelve unstratified sherds are all from the same vessel. All the breaks appear to be new, and most of the dish survives. The fabric again contains mica, and small flint and chalk inclusions, but is apparently fired to a redder colour than the

cremation vessel, and has a grey core. It is wheel-made but hand-burnished, the latter being sometimes non-horizontal. Lines have been incised on this vessel internally just below the rim, and a neat circle of 12mm dia. is incised centrally on the under surface of the base, perhaps copying samian.

A close examination of this vessel suggested that the original surface may have been mica-dusted, giving it a golden appearance, but this is not certain. The vessel appears to have seen some use. The dish appears to be burnt internally up to the line delineating the internal rim. The external base of the vessel shows virtually no sign of fire. However, there is a small patch, possibly burning, on the base of the external wall in one place.

3. *SF7 Red ware dish*. Rim dia. 140mm. Ten sherds. All the breaks seem new, and about one-

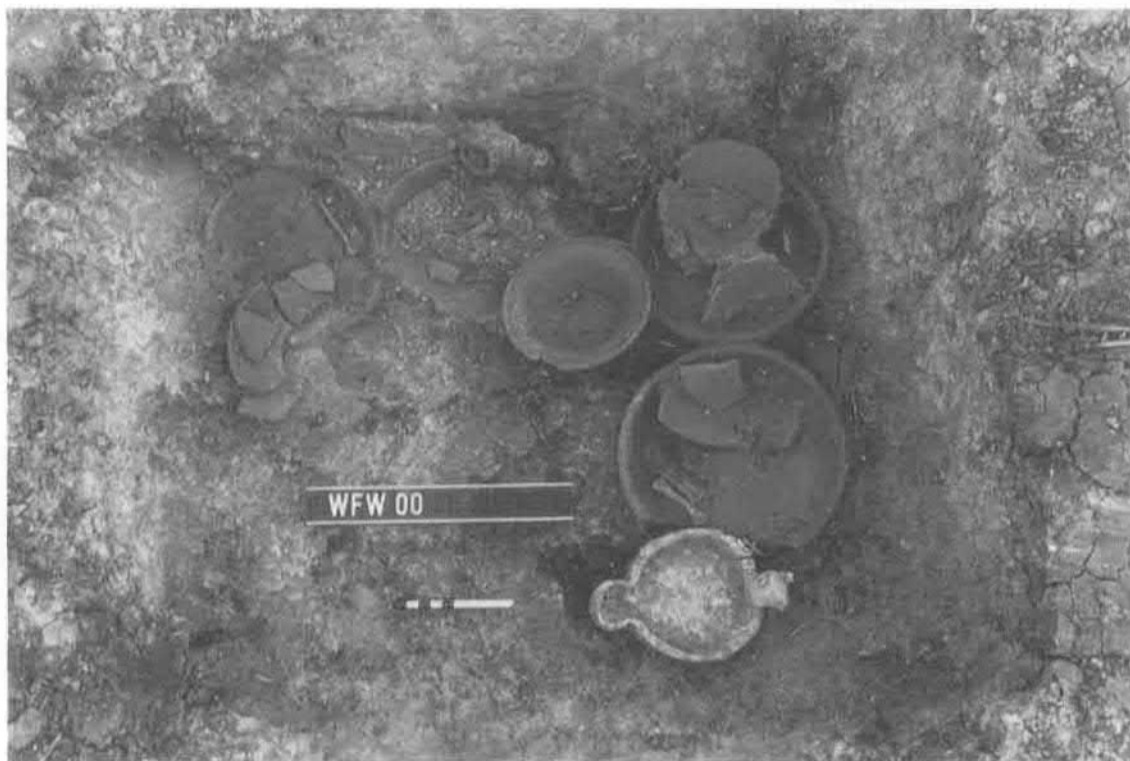

PLATE 2 The cremation, as excavated (ASC Ltd).

fifth of the rim is missing. The fabric is identical to Vessel 2. Marks from the adherence of small fragments of bone survive on the internal base. There are again virtually no signs of contact with an external fire.

4. *SF9 Red ware dish*. Rim dia. 140mm. Nine sherds. Again the breaks are new, and almost half the vessel is missing. The fabric is identical to Vessels 2 & 3, and there are hints of possible mica dusting. This vessel had a line incised on its base externally, in this case with a diameter of 60mm. There is no sign of external burning. Again, there is also adherence of small fragments of bone on the base.

Dating of the red-ware dishes: The form is not an easy one to date, this simple shape running throughout the Roman period. If, however, the vessels were originally mica-dusted, a mid-to-late second-century date would be normal, and a later date unlikely (Swan 1988, 13–14).

5. *SF8 Triangular-rim platter*. Rim dia. 155mm. Seven sherds. Well-potted, in a wheel-thrown black ware with cross-hatched decoration, copying a Dorset Black-Burnished Ware form. The fabric has a good matt-black surface, and is in a dark sandy fabric with black inclusions, apparently haematite, plus fine quartz inclusions – which give a slight surface glitter, and occasional flint inclusions. There are reddish margins beneath the black surface.

The triangular rim is a standard Antonine form, *i.e.* post *c.*AD 140, and the form and the angle of the lattice decoration, which changes with time, also confirms a date of the early to mid second century. (*c.f.* Wilson *in* Frere 1972, 721, dated 130–150 AD, here with parallel oblique lines only. Also Gillam 1976, fig. 4.54, from Leicester, early to mid second-century with similar chamfer and cross hatching, and Marney 1989, fig. 10.7, there dated early to third quarter of the second century, and fig. 11.23 and 28, there dated mid to late second

century. See also Woodfield 1983, fig. 19.8, where the vessel is dated earlier to mid second century).

Samian Ware

Hedley Pengelly

The samian recovered from the burial comprises four complete, or nearly complete, vessels from Hadrianic-Antonine Central Gaul: two dishes of Form 18/31–31 (6, 7), showing hitherto unrecorded potters' stamps, and two cups of Forms 33 and 46 (8, 9), showing inscribed circles in their bases. Vessels 6, 7 & 8 are in fragments (a combination of both ancient and, due to their mode of discovery, mostly modern fractures), while vessel 9 is whole, save for a small area broken away from the rim. All have worn footings, as if they had been in use for a time before incorporation in the burial, while the two dishes have similar, post-firing graffiti cut under their footings. Vessels 7 and 9 show slight evidence of ancient handling wear and some abrasion round their rims. This, together with the relative degree of wear to their footings (and to the centre base of the pock-marked Vessel 7), suggests more use than Vessels 6 and 8, though not necessarily over a longer, or much longer, period of time. None of the vessels are technically outstanding: in fact, perhaps appropriately, this is a somewhat basic workaday homogeneous group, whose forms, fabrics, finishes, and stamps suggest manufacture c.AD 130–155.

Catalogue (Fig. 4)

What follows is based partly on information kindly supplied by Brenda Dickinson, from the vast mass of material gathered for the forthcoming *Leeds Index* of samian potters' stamps.

6. *SF5. Form 18/31–31*, on the borderline between the two forms. Sixteen pieces. Fabric: pale pinkish, fine: slip, light orangey-red. In dipping the vessel, finger marks were left on the base and footing, with a consequent thinning and blotching of the slip at those points. Stamped: **IVLLIX** plus, none too clearly, a phallus and palm branch in an elaborate arrangement. *Iullix* of Les Martres-de-Veyre, Die 1a. Not hitherto recorded in the *Leeds Index*. The literacy of the stamps assigned to this potter may be dubious, but some form of **IVLLIX** is

common to all the dies (c.f. Terrisse 1968, p1. LIII, Col. 2, 3–5). The use of palm branches, as here, fits well with the later Martres group of c.AD 130–155/60 (Buturo, Cettus, Gnatius ii, Suobnus, etc, regularly used such devices), though, interestingly, phalli are not otherwise known in stamps at that kiln. The potter's forms, including 18/31 and 27, reinforce the date of his stamps as Hadrianic-Antonine, and the fabric and finish of this dish (as with Vessels 7–9) are in accord with such dating. Graffito **II** cut under the footing.

7. *SF3. Form 18/31–31*. Broken into two pieces. Fabric, pink, coarse with much 'filler': slip, red-brown. Stamped: **IIIIIIIIII** from a die damaged along the top. Illiterate stamp from Lezoux but again, not recorded in the *Leeds Index*. The style of the stamp is Hadrianic-Antonine. Graffito **II** cut under the footing.
8. *SF1. Form 33*. Small early example of the form, nine pieces. Fabric pink, but finer than Vessel 7: slip red-brown. Lezoux. The potter's stamp was omitted, so that only an inscribed circle of a kind commonly surrounding such stamps is present in the base.
9. *SF6. Form.46*. Large cup. Fabric and slip as Vessel 7. Lezoux. A small inscribed circle in the base instead of a potter's stamp, as often with this form.

The Animal Bone

James Rackham

The animal bone from Vessels 3, 5 & 6 was submitted for identification. A detailed catalogue is retained in the site archive.

All the bones were identified as chicken, and all had undergone some erosion in the soil, particularly surface corrosion caused by plant rootlets. However, this was not severe enough to suggest that some bones may have been lost entirely from the deposits through this corrosion. None of the bones are burnt, indicating that they were not placed on the pyre with the human body, but offered up afterwards during burial.

None of the bone fragments in any of the vessels duplicate each other. Furthermore within each vessel there is an indication that some bones are paired, for instance the ulnae from Vessel 3 are left and right bones, and both are almost identical in length. It seems probable that all the bones derive

from one chicken carcass, although this cannot be said with absolute certainty. Vessel 3 contained some of the distal parts of both wings, the ulnae and carpo-metacarp, plus parts of the upper right leg, femur and tibia, and part of the acetabulum, the pelvic articulation for that femur. Vessel 5 contained only the shaft and distal end of a left tibia. In Vessel 6 were the upper part, humerus, of one wing and the attached coracoids and part of a clavicle or wishbone. If the bones all derive from one bird, this pattern suggests that the carcass was dismembered with the front part of the breast with coracoid, wishbone and a humerus attached placed in one vessel. The tips of both wings and an upper right leg were placed in the second, and part of the left leg in the third. Some of the bones were probably articulated when they were deposited, although whether they still carried meat is another matter. There are no bones of the sternum, that part associated with the breast meat, the largest part of the bird. A considerable part of the edible chicken carcass is missing and presumably was not deposited. The absence of the tarso-metatarsus, the bone that carries the spur, means that the bones cannot be sexed.

In conclusion the bones appear to represent a food offering of parts of a single chicken carcass divided up, probably still articulated, between three vessels in the cremation burial.

DISCUSSION

The Wellwick Farm burial comprises a cremation, sex, age and gender unknown, contained in a pottery vessel – probably a two-handled flagon, and accompanied by eight ceramic vessels, two glass vessels, a lamp and an adze-hammer. Food offerings had been placed in at least three of the ceramic vessels. This assemblage had been placed in a wooden box or casket, and buried in a relatively shallow pit in an apparently isolated location, several hundred metres from the nearest known Roman site. The burial has been dated by its associated pottery to c.AD 135–155.

The relatively late date of the cremation has been commented on in the coarse pottery report. Cremation burials in the Roman period are generally of first and early to mid second-century date, being essentially a continuation of a native tradition of the late Iron Age that is gradually supplanted by inhumation from the mid second

century onwards. Although finds of single cremations are not uncommon, this form of burial is normally associated with cemeteries, as at Skeleton Green, Herts (Partridge 1981) or Bancroft, Bucks (Williams & Zeevat 1994). This does raise the possibility that the Wellwick Farm cremation is one of a group: perhaps, like the Bancroft cremations, a family cemetery related to a nearby occupation site.

Cremation burials in wooden boxes or caskets are not uncommon in the Roman period. In the extensive cremation cemetery at Skeleton Green, a number of casket burials of later second-century date were examined (Partridge, *op. cit.*). In these, the cremated bone was placed in a pit in a wooden casket, accompanied by pots presumably containing offerings. At Baldock, Herts, two late first-century cremation burials were found where the cremation assemblages were contained within wooden boxes nearly twice the size of the Wellwick Farm burial. Fittings and wooden parts of one box survived. (Stead & Rigby 1986, 61–71). At Thornborough, Bucks, excavation of a small Roman cemetery revealed one late first-century burial comprising an urned cremation accompanied by a samian dish, within a box about 300mm square (Johnson 1975). In 1855 a Roman burial was found in the garden of the Rectory at Weston Turville, 3km north of Wellwick Farm (Waugh 1975). The cremation was contained in an amphora, accompanied by three glass bottles, two samian dishes and a cup, a bone pin and fragments of a mirror. Pieces of iron, apparently the bindings of a wooden box, were also present. This burial has been dated to c.AD 150. Finally, at Radnage, Bucks, a Roman cremation burial was recovered in the early years of the last century. This differed from the above in that the cremation was contained in a wooden casket, with iron straps and bronze rings. The casket was accompanied by a fine pillar-moulded blue-glass bowl, a flagon and nine samian dishes (*Records* 11, 242–243).

Apart from the presence of a casket, two other features of this burial deserve comment. The occurrence of lamps in burials has already been noted to be a relatively common practice, at least in East Anglia, which may now be seen to extend further westwards across Roman Britain. The adze-hammer, and its possible indication of the deceased's occupation, is less easy to interpret. Indication of the deceased's occupation sometimes appears on tomb-

stones, normally for soldiers (e.g. Brailsford 1964, 60 & fig. 28), the writer knows of only one other contemporary burial where an implement such as this has been included. This was at the Wards Coombe cemetery, near Ivinghoe, where a possible leather-working knife was found in a late Iron Age cremation burial (Dunnett 1972). It is clear from the presence of the adze-hammer in the Wellwick Farm burial that the deceased's occupation was connected with woodworking. However, the precise occupation that it indicates must remain in doubt. 'Carpenter' and 'cooper' have already been suggested: to these should perhaps be added 'wheelwright'.

Finally, the inclusion of food offerings in Roman cremation burials appears to be a common practice. The casketed cremations found at Baldock (Stead & Rigby 1986, 61–71) both contained bones from domestic fowl, as well as sheep and pig bones. Many burials in the cremation cemetery adjacent to the villa at Bancroft, Milton Keynes, were also associated with bones of sheep, pigs and domestic fowl (Williams & Zeepvat 1994, 63–72). From the available examples there does not appear to have been any religious preference for any particular kind of meat: joints of fowl and smaller domesticated animals would of course have been of a size suitable for inclusion within the confines of a cremation burial. Considering that the bones in the Wellwick Farm cremation occupy only three of the eight vessels present (excluding the cremation vessel itself), it is tempting to suggest that the remaining vessels contained non-meat food offerings and, in the case of the two cups, drinks.

ACKNOWLEDGEMENTS

The writer is grateful to members of the *Weekend Wanderers Metal Detector Society*, particularly Paul Egan, for their interest in the project and prompt reporting of the discovery. The cremation was initially identified by Martin and Adam Parker, who provided additional assistance during the excavation. Following reporting of the find an initial reconnaissance visit was made by Michael Farley.

Funding for the excavation and preparation of the publication report was made available by the County Archaeology Advisory Committee, and the work was commissioned and monitored by Sandy Kidd, Senior Archaeological Officer for the County Archaeology Service.

The excavation was carried out for ASC by David Fell and Nigel Wilson. David Parish of the County Museum undertook reconstruction of the fine glass vessel. The finds were illustrated by Paul Woodfield. The writer is grateful to all the specialists who have contributed to this report for their contributions and their continued interest.

BIBLIOGRAPHY

- Anon. 1926 'Roman Remains at Radnage', *Recs Buckinghamshire* **11**, 242–243.
- Bailey, D.M. 1996 *A Catalogue of the Lamps in the British Museum. IV: Lamps of Metal and Stone, and Lamp-Stands*. (London).
- Brailsford, J.W., 1964 *Guide to the Antiquities of Roman Britain*, 2nd edition. British Museum (London).
- Branigan, K. 1967 'Romano-British Rural Settlement in the Western Chilterns', *Archaeol. J.* **124**, 129–159.
- Dunnett, B.R.K. 1972 'Report on the Trial Excavations at Wards Coombe, Ivinghoe, 1971', *Recs Buckinghamshire* **19**, 141–155.
- Evans, J. 1890 'On Some Iron Tools and Other Articles formed of Iron, found at Silchester', *Archaeologia* **54**, 139.
- Fell, D. 2000 *Archaeological Recording at Wellwick Farm, Wendover, Buckinghamshire*. Archaeological Services & Consultancy Ltd, ASC/WFW00/2.
- Frere, S.S. 1972 *Verulamium Excavations I*. Reports of the Research Committee of the Society of Antiquaries of London **28** (London).
- Gillam, J.P. 1976 'Coarse Fumed Ware in Britain and Beyond', *Glasgow Archaeol. J.* **4**, 57–80.
- Isings, C. 1957 *Roman Glass From Dated Finds* (Groningen).
- Johnson, A.E. 1975 'Excavations at Bourton Grounds, Thornborough', *Recs Buckinghamshire* **20**, 3–56.
- Manning, W.H. 1976 *A Catalogue of Romano-British Ironwork in the Museum of Antiquities, Newcastle upon Tyne* (Newcastle).
- Manning, W.H. 1985 *Catalogue of the Romano-British Iron Tools, Fittings and Weapons in the British Museum* (London).
- Marney, P. T. 1989 *Roman and Belgic Pottery from Excavations in Milton Keynes, 1972–82*. Buckinghamshire Archaeol. Soc. Monog. Ser. **2** (Aylesbury).
- Mynard, D.C. (ed.) 1987 *Roman Milton Keynes*,

- Excavations and Fieldwork, 1971-82*. Buckinghamshire Archaeol. Soc. Monog. Ser. 1 (Aylesbury).
- OS 1979 *Ordnance Survey Map of Roman Britain*.
- Partridge, C. 1981 *Skeleton Green: a Late Iron Age and Romano-British Site*. Britannia Monog. Ser. 2 (London)
- Price, J. 1987 'Glass' in Mynard 1987, 147-157.
- Price J. and Cottam, S. 1998 *Romano British Glass Vessels: A Handbook*. Practical Handbooks in Archaeology 14. Counc. Brit. Archaeol. (York).
- Reed, M. 1979 *The Making of the English Landscape: The Buckinghamshire Landscape*. Hodder & Stoughton.
- Scott, E. 1993 *A Gazetteer of Roman Villas in Britain* Leicester Archaeol. Monog. 1 (Leicester).
- Soil Survey 1983 *The 1:250,000 Soil Map of England and Wales* (Harpenden).
- Stead, I.M. & Rigby, V. 1986 *Baldock: the Excavation of a Roman and pre-Roman Settlement, 1968-72* Britannia Monog. Ser. 7 (London)
- Swan, V.G. 1988 *Pottery in Roman Britain*. Shire Archaeology (Princes Risborough).
- Terrisse, J-R. 1968 *Les ceramiques sigillées gallo-romaines des Martres-de-Veyre (Puy de Dôme), XIX^{ème}*. Supplement à Gallia (Paris).
- Waugh, H. 1972 'The Romano-British Burial at Weston Turville', *Recs Buckinghamshire* 17, 107-114.
- Williams, R.J. & Zeepvat, R.J. 1994 *Bancroft A Late Bronze Age/Iron Age Settlement, Roman Villa and Temple-Mausoleum*. Buckinghamshire Archaeol. Soc. Monog. Ser. 7 (Aylesbury).
- Wilson, M. 1972 'The Pottery', in Frere 1972, 263-370.
- Woodfield, C., 1983 'The Pottery' in Brown, A.E. & Woodfield, C. 1983 'Excavations at Towcester, Northamptonshire: the Alchester Road Suburb', *Northamptonshire Archaeol.* 18, 43-140.
- Zeepvat, R.J. 2000 *Wellwick Farm, Wendover, Buckinghamshire: Method Statement for Excavation*. Archaeological Services & Consultancy Ltd, ASC/WFW00/1.