

# BUCKINGHAMSHIRE POTS, POTTERS AND POTTERIES, c.1200–1910

MICHAEL FARLEY AND BARBARA HURMAN

*An attempt is made to list Buckinghamshire's pottery production sites and potters from the thirteenth century until c.1910 and to give a short description of their products where known. The information is derived from confirmed kiln sites, from surface finds of 'waster' material which indicate production, and from a range of documentary sources including field names. There remains considerable scope for further local research; a number of suspected production sites have not yet been located on the ground and further local study would certainly identify other potters and link named potters to specific locations.*

*Several features have emerged from the study. Firstly, a number of production sites are known to have been active in recent centuries, but for which there is no earlier record. It is suspected that some of these may have had earlier undocumented activity. Secondly, and perhaps unsurprisingly, many pottery centres were located on agriculturally marginal land. Thirdly, several of the pottery families followed their trade over generations and this is likely to have been the case long before documentation becomes available. Finally, the number of 'pot hawkers' recorded, particularly in the mid-nineteenth century, is surprising as it almost equals the number of working potters; their role in distributing the wares of country potteries may have been underestimated in the past.*

## INTRODUCTION

Until shortly before the Roman conquest all pottery used in Buckinghamshire was handmade, having been formed without benefit of the momentum of a potter's wheel ('throwing'). During the Roman period in Buckinghamshire, as elsewhere in England, wheel-thrown pottery became common, but in the immediate post-Roman period the technique fell out of use only to reappear during the eighth century in some areas of England, notably East Anglia. In Buckinghamshire, throwing does not seem to have been utilised again until the thirteenth century, although handmade vessels may well have been rotated while being made on a support such as a pre-fired dish, a process which is still common elsewhere in the world, for example India. For a useful summary of pottery development in the adjacent county of Oxfordshire see Mellor (2010) and in Britain as a whole McCarthy & Brooks (1988).

Hand-made pots which are generally fired at a relatively low temperature in bonfire-type kilns often have a fairly open fabric with added inclusions that can help in minimising thermal shock and fracture of a vessel. If such sherds are subse-

quently exposed, for example by being ploughed up, weathering of their relatively soft and open fabric may leave little trace of them. In contrast, wheel-thrown pots which commonly have fairly dense fabric, when reduced to sherds through breakage, are generally able to survive weathering better, and surface finds of sherds of such denser fabric can be readily identified. In addition, wheel-thrown pots are almost invariably fired in re-usable purpose-built kilns. The capital investment in constructing them means that these production sites can have a reasonably long life: this in turn results in there being a considerable number of broken sherds lying around indicating a kiln's presence below ground.

The shift from the production of hand-made vessels which could be readily produced on a domestic scale, to the production of wheel-thrown pots, seems also to have led to the development of greater craft specialisation. Recognition of this in the medieval period can occasionally be seen in personal names such as 'Sampson le Potter' who was working at Brill in the early thirteenth century.

Overall therefore, production sites of the medieval (or Roman) periods are easier to identify on the ground than those of prehistoric or Saxon date. However, the discovery of plentiful sherds

at a location is of course not in itself sufficient to identify a production site; other factors such as the presence of 'waster' sherds from spoiled pots needs to be taken into account in order to distinguish between debris arising from domestic occupation and production sites. The identification of production sites is of considerable interest, since it provides insight into a frequently undocumented but significant aspect of the medieval rural economy.

The thin-sectioning of pottery sherds in order to examine the materials from which they were made and the source of their fabric has been standard practice for many years, and chemical analysis both of fabrics and of residues surviving on surfaces or absorbed within the vessel body is also becoming more common (e.g. Blinkhorn 2012). A good local example of what can be done with archaeologically-recovered ceramic can be seen in the work of Mellor (1994) who has described excavated pottery from Oxfordshire, and used fabric analysis and details of form and distribution to complement dating from archaeological excavations and documentary research. From a study of deposits excavated within the city of Oxford she has noted, for example, that Brill-Boarstall wares were in production before AD 1231 and 'were 'evident in considerable quantity' by the mid-thirteenth century. She illustrates numerous forms of vessel produced by the Brill-Boarstall potters over the centuries – greater than that evidenced by finds from kilns so far excavated at the villages themselves – and includes colour illustrations of the fine decorated jugs produced there in the thirteenth century. Oxford was a very important local market for the Brill-Boarstall potters, but she notes that examples of their wares are occasionally found as far away as Gloucester, Bedford, and Northampton, not only in towns but also on rural sites such as West Cotton, Northants (Hinton 2010). Locally, Brill-Boarstall wares are particularly common in Aylesbury.

Brill, as will be seen further on, was a special case. That the king occasionally stayed at Brill with a large accompanying retinue will certainly have helped the local potters. When orders for pots were placed by institutions they could be substantial. For example, the Kingston-upon-Thames potters, as Le Patourel (1968, 120) notes, received orders between 1200 and 1265 from royal and monastic houses for between five hundred and a thousand

pitchers at a time. These particular 'pitchers' were probably small handled jugs used as mugs or tankards rather than the larger jugs commonly associated with the word pitcher today.

In contrast to Mellor's work on the Brill products, another piece of regional research that examined a group of 'greywares' which had shared similarities in form, showed – more confusingly perhaps – that this particular group was probably produced not at a single centre, but at several locations in Bedfordshire and one at Great Brickhill in Buckinghamshire (Slowikowski 2011). A similar conclusion was reached in a study by Museum of London ceramic specialists who studied the fabric and distribution of 'greywares' common in south Buckinghamshire and the Chilterns in general. This study showed close similarities both of clay and vessel form between the products of the Buckinghamshire kilns at Rush Green, Denham noted below, and others just across the county boundary in Uxbridge (Blackmore & Pearce 2010, 88, 114–18, 132, 276). This might indicate a family of potters, or at least near-contemporaneity of operation, perhaps with one potter copying another. In contrast to the distribution of Brill/Boarstall products, the authors show that these relatively mundane vessels, which were produced at many kilns in the Chilterns, appear to have been distributed over a maximum distance of c.16 km from their source, and that only rarely were attempts made to glaze them (Blackmore & Pearce 2010, 130). County boundaries were never a barrier to trade: for example, both the products of the Potterspury group of Northamptonshire (Mynard 1970) and probably those of Heath and Reach in Bedfordshire (Slowikowski 2011, 9, 13) were popular in north Buckinghamshire.

In addition to the discovery of production sites through fieldwork, from the thirteenth century onwards some documentary evidence recording the presence of Buckinghamshire potters also becomes available, although interpreting this is not always straightforward. Personal names, for instance, are a difficult area. Le Patourel (1968) notes of the early post-conquest period that '...A very high correlation is found between the presence of Potter surnames in taxation or other records and the existence of field names containing the potter or crocker element.' So, there is no doubt that Sampson le Poter, recorded in the thirteenth century at Brill, was a potter but by the mid-fourteenth century surnames in general did not

necessarily have a link with the craft. Much later for instance, in 1607 the Chesham parish registers note that John Potter was a tanner. Apart from personal names, field and other locality names also provide much scope for local research. Dyer (2008), examining place names, found that of thirty place names which included ‘potter’ or ‘crock’ elements, more than two-thirds proved also to have direct evidence of pottery production on the ground. A local example of this can be seen in Potter Row in Buckinghamshire. Unfortunately, where such names do occur in early records, for instance as furlong names, their location on the ground can often only be determined in the most general manner.

Buckinghamshire is well-supplied with the basic needs of the pottery industry, possessing a range of clays suitable for the body of earthenwares, although sources of the white-firing clays which became increasingly important over time both for finer wares and for use in slips are rare (Cocroft 1985). Wood for kilns was initially easy to come by in the Chilterns and other partially-forested areas such as Bernwood and Whittlewood, but over time wood may have become less available in much of the Vale of Aylesbury in central Buckinghamshire, which had substantial open fields achieved through clearance of woodland. Lead, which was the main fluxing ingredient for forming glaze, would have been dependent on outside supply from a considerable distance. Some pottery inventories of the seventeenth and later centuries in Sussex record stocks of lead (Tankard 2008, 174). Lead would have been applied as a powder of lead oxide (litharge), lead sulphide (galena), or lead carbonate (white lead) (Newell 1995: Hurst & Freestone 1996). It was initially just dusted on or applied in a paste form (Newell 1995, 77–8), but was later used in solution which enabled dipping and a better coverage. Handling lead was a risky process, but it was a long time before it was recognised that dealing with the poisonous raw product was hazardous. Even in the post-medieval period Stebbing *et al* (1980, 9) notes that lead ‘caused the early death of at least one potter’ at Nettlebed (Oxon.). The distribution of all known Buckinghamshire potteries is shown in Fig. 1.

The equipment used by potters in Buckinghamshire is rarely mentioned in surviving records. One exception is the construction of a clay mill on Coleshill Green in 1768. This would almost

certainly have been a simple rotary horse-mill used in mixing clay to an even consistency (a pug mill), and adding other ingredients such as sand if required (e.g. Bedfordshire County Council 1979, 22). Although some long-disused brick kilns still survive in Buckinghamshire and there are illustrations of others, this is not the case with pottery kilns. Only two images of working Buckinghamshire pottery kilns of the period are known to the writers. One is a photograph of a bottle kiln on the edge of the common at Brill (Prosser 1999, 95) here Fig. 20. Although it is not described as such in the text, its circular form and protruding ground-level arches would give a plan form matching that of an excavated nineteenth-century pottery kiln at Tram Hill, Brill (Gazetteer). A photograph of ‘The Potters Arms’ at Winchmore shows the adjacent kiln and a separate chimney (Fig. 6). A splendid oil painting of Brill Common by Edmund Niemann of 1858 in the County Museum does show some kilns, but most appear to be brick kilns. Only one known photo of a potter at work is known; the ‘last’ Buckinghamshire potter at his kick-wheel, at Winchmore Hill (Fig. 8).

From the seventeenth century onwards most Buckinghamshire potteries produced mainly earthenware with a slightly ‘bricky’ colour and texture, with varying coverings of plain lead-glazes which generally fired to shades of brown. They were not innovative and from the later sixteenth century competition from potteries beyond the county boundary that produced better-looking or more durable wares, such as stonewares, tin-glaze earthenware, Staffordshire slipware, bone china and porcelain, in combination with increasingly effective transport networks for distribution, had certainly affected local production. For a study of the effects of imports and changing social fashions on British pottery during this period see Gaimster (1994). At a much later date Davies (1912, 98) accounted for the decline of the Winchmore Hill pottery partly to ‘the cheapness with which pottery can be brought from North Staffordshire’, but also attributed the decline ‘in part to the replacement of pottery by tin-ware and iron-ware for many domestic purposes’. As the nineteenth century progressed the remaining Buckinghamshire potters increasingly turned their hands to the production of larger vessels that would have been expensive to transport any distance, such as basic kitchen wares, or to items where large numbers of

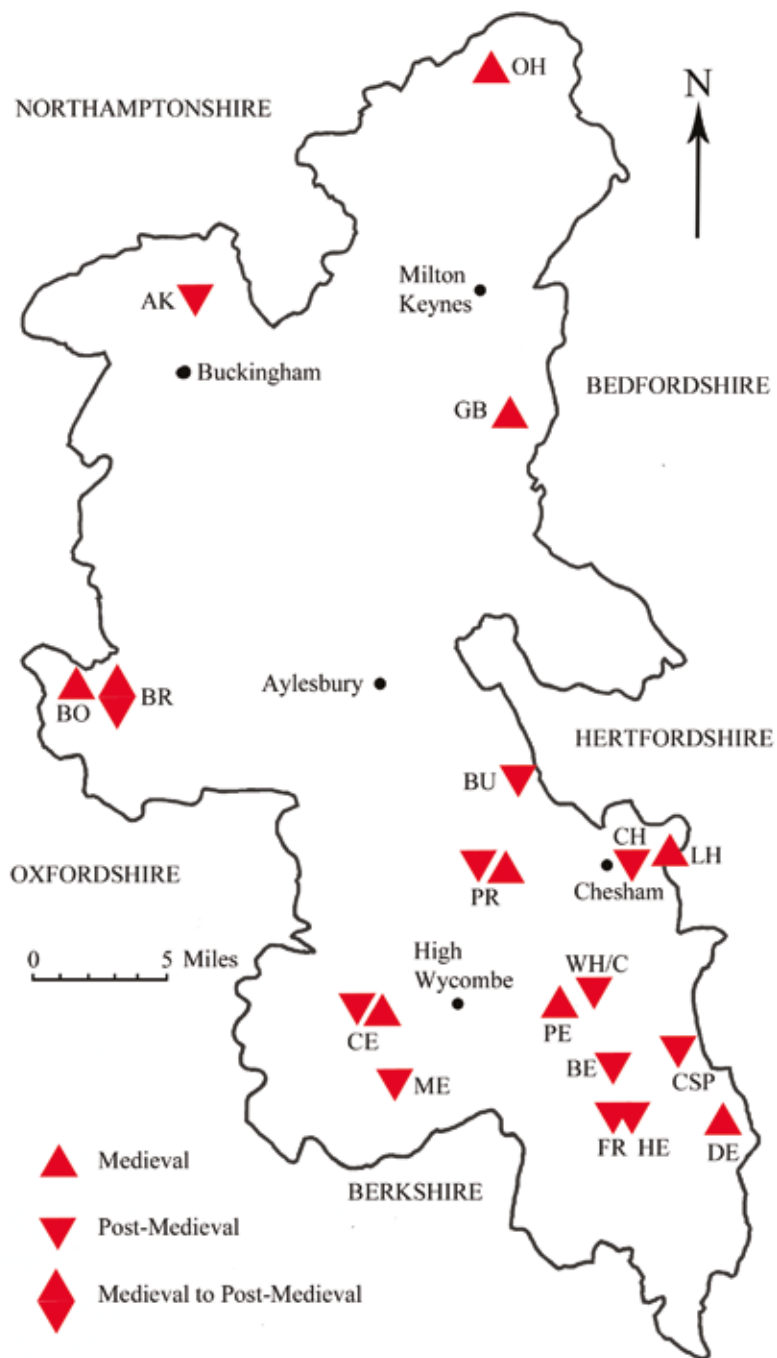

FIGURE 1 Buckinghamshire medieval and post-medieval potteries. Uncertain locations not included

Key: OH Olney Hyde; AK Akeley; GB Great Brickhill; BO Boarstall; BR Brill; BU Buckland; LH Ley Hill; CH Chesham; PR Potter Row; WH/C Winchmore Hill/Coleshill; PE Penn; CE Cadmore End; ME Medmenham; BE Beaconsfield; CSP Chalfont St Peter; FR Farnham Royal; HE Hedgerley; DE Denham.

the same type (such as flowerpots) were required. Nevertheless as the census shows, some mid-nineteenth century Buckinghamshire potteries, such as those at Winchmore Hill where many potters were employed, must still have had a considerable output. For an interesting study of the later traditional country pottery and its products in general, see McGarva (2000).

The earliest documented reference to a potter in the region occurs in a Domesday entry for Oxfordshire (1086) from whom the lord received 10s (Morris, 1978, 156a); the amount indicates that production was flourishing here. For medieval Buckinghamshire there are rare clues about the value of pots. For example, the accounts prepared for the Bishop of Winchester's property in 1301–2 give a year's expenditure for dairies at Ivinghoe 'In earthenware pots and pans bought 3 1/2d'; at West Wycombe 'In earthenware pots and pans bought 2d' and at Morton 'In earthenware pots and pans bought 1 1/2d' (Page 1996, 163, 170, 155). These were not large sums. In sixteenth-century wills such as that of Richard Alchyn of Stony Stratford, the only vessel materials specified are pewter or brass (Elvey 1975, e.g. 445). Ceramic vessels are rarely itemised in later probate Buckinghamshire inventories either. Of the 159 post-medieval inventories transcribed by Reed (1988), most of which include the contents of kitchens, ceramic is rarely noted. A rare example is the listing of the property of Ann Pretty of Eton in 1694, who died possessed of vessels of pewter and brass (mostly given by weight) as well as those of iron, tin and stone, and as an afterthought 'earthen potts and pans' with a combined value of 2s (*ibid*, no. 132). Following a disastrous fire at Stony Stratford in 1736, many inhabitants listed their losses. They included Peter Franceway, who from his house lost 'Other earthenware from Brill' at a value of 1 shilling and 10 pence (Q/FR/128/24). Another inhabitant noted 'wood ware, white ware and earthenware' (128/33). Trenchers are often mentioned, for example a dozen valued at 2s, although these were probably of pewter at this date, rather than wood or earthenware (128/54). A more refined household lists a quantity of china cup and saucers as well as '3 delf basons and 2 plates', which together with other goods were valued at 10s 2d (128/56).

The sale of pots made in Buckinghamshire certainly took place at the production point and at markets and fairs, but at some point a distinct

class of pot hawkers arose. They were particularly numerous in the nineteenth century around the Winchmore Hill industry. The earliest hawker is recorded in 1798 at Woodrow, Amersham. Morley Davies (1912, 98) writes of 'the district around Chalfont' that 'Within living memory, the pottery from this district, carried in panniers slung across asses' backs used to be hawked around the streets of Wycombe.' Pottery dealers certainly also travelled further afield, as was the case of Thomas Carter, a Winchmore Hill dealer, who was selling pots at Winslow in 1827, but potters no doubt also sold to established urban dealers. Vaisey and Celoria (1974) for instance, note an Oxford mercer selling pots in 1597, and another in 1645 at Maidenhead. A 1688 Marlow inventory of the contents of the shop of Silvester Widmere, a mercer who dealt mainly in textiles, noted that his stock also included £5 worth of earthenware (Reed 1988, no 15). A very full inventory of George Ecton's premises at Abingdon, Berkshire in 1698 records that his stock included quantities of glasses and bottles, and also a considerable range of ceramic including: 'chamber pots, paynted basons, dishes, porringers, caudel cups, gallipotts, fine mugs and stone mugs, cheafing dishes and pans, blk cups, flower pots' etc.

Evidence for brick and tile production sites, which were common in the county due to the scarcity of good building stone (Pike 1995), have not been included in the gazetteer which accompanies this article. Neither have eighteenth and nineteenth-century references to unspecified 'kilns' been included since, unsupported by evidence to the contrary, these commonly prove to be brick and tile kilns. However, the production of brick, tile and domestic ceramic were often closely linked from an early date, notably at Brill and probably at Penn. The latter has long been known as an important centre for the production of decorated floor tiles during the fourteenth century (e.g. Green 2005), but research in recent years has also demonstrated that pottery was produced here, and there is evidence from elsewhere that roof furniture such as finials and louvers were produced alongside pottery in the medieval period. The close link between pottery and tile production is graphically demonstrated at Ley Hill, Chesham, where a pottery kiln of fifteenth-century date was built *inside* a disused tile kiln (Farley & Lawson 1990). In the same area there is documentary evidence

for tilers long before any mention of potters: this is also the case at a rather later date for the Coleshill/Winchmore Hill area. However, as can be seen at Penn, this may reflect the character of the documentation available rather than the practical reality on the ground. Because of the volume of tiles required to roof a building and their transport costs, the expense is more likely to appear in e.g. manorial building accounts.

Farmers often had brick kilns on their land and could use their labourers for agricultural work or at the kilns. By the nineteenth century the overlap between the trades of brickmaker and potter can also occasionally be seen, for instance at Akeley. This sometimes unsatisfactory combination of the two industries can also occasionally be seen in pots whose 'bricky' fabric lacks aesthetic appeal (Farley & Hurman 1978). Trade directories sometimes list individuals as both potters and brickmakers. By the later nineteenth century the closeness can lead

to uncertainty as to how much, if any, pottery was actually produced at a location. For example the 'Slough Pottery' (Gazetteer) seems to have been mainly a builder's merchant. It was quite common for potteries to evolve in this manner as the local demand for domestic wares dried up. As a footnote it may be noted that the well-known Buckinghamshire studio potter Michael Casson (Fig. 2) who had a studio at Prestwood between 1959 and 1977, and is well known for his BBC television series 'The craft of the potter', had a completely different link to a local brickyard; he added brick-dust to his basic clay which gave it a 'little more resilience and also results in the slightly speckled effect that his pots have.' (Rotheroe 1966, 7).

Although we have endeavoured to utilise census data, we are conscious that a more intensive study would provide better results. The location of the potteries themselves is rarely clear from census data; the addresses given are of course of a potter's



FIGURE 2 Mick Casson (who had a studio at Prestwood between 1959 and 1977), photographed with Colin Pearson in about 1977 (© Ben Boswell).

residence, not necessarily his place of employment, and can themselves be vague to modern eyes. Often it is necessary to refer to the bounds of the census district and enumeration area to establish even an approximate locality for an individuals' residence, and an informed guess may have to be made as to his place of employment. Further local study, for example of ownership and tenancies of properties associated with them, should enable most active potteries to be located with precision, as Hunt has demonstrated for some properties in Coleshill (Hunt 2009).

Descriptive terms for potters vary within and between censuses: some are called 'potters', others 'pot maker', or 'journeyman potter'. 'Pot boy' always refers to young people working at public houses and frequently the same applies to those described as 'potman'. We are conscious that more detail than we have been able to analyse relating to employment practice and family matters could be obtained from further local study. Potting families often pursued their trade over generations, and there were often clear familial ties between them through marriage. For instance William Slade's wife came from Leafield, a potting area in Oxfordshire (1881 census). On occasion, potter's wives returned to their familial home to give birth; older potters also often took younger potters in as lodgers. The employment of a potter's own children on the premises was common. Occasionally we learn in a census that a potter employed several men, but their names have to be deduced from potters domiciled in the general area. There is only one direct reference to a female potter, Mary Hubbocks at Brill, although Mrs Saunders who took over the Beaconsfield pottery in c.1884 clearly had much experience in the trade.

Archaeological evidence on occasion indicates examples of the movement of unnamed potters. Mellor (1997, 36–7) for example notes that wasters found at Combe in north-west Oxfordshire 'were typologically and stylistically identical to Brill wares, but potted in distinctive clay'. Later censuses and other sources have direct evidence for the movement of individuals between potteries. Occasionally this was from some distance, as is the case with John Andrews who came to the Beaconsfield Pottery from Hanley (one of the 'Pottery Towns'), but movement also took place between local potteries, for example Emmanuel Pratley moved from Buckland to Winchmore

Hill. Stebbing *et al* (1980) writing about Oxfordshire potters, notes George Slade and John Sears, both Buckinghamshire potters, who were working at Adderbury in the 1840s. A list of Oxfordshire potters (*op. cit.* 27–29) includes two other Buckinghamshire potters, George Readings (1861) and Joseph William Slade (1865) who were working at Stoke Row.

The last pottery to be established in the county, prior to the arrival of the post-war studio-pottery movement, was the Medmenham Pottery based at Marlow Common, which had no local predecessors. It was set up in 1897 and had a relatively short but highly successful life there, before being transferred to Staffordshire in c.1908 (see under Great Marlow in the *Gazetteer*). By 1911 the only potter to be listed in *Kellys Directory* was Mrs Saunders at the Beaconsfield Pottery. For the emergence of the later studio-pottery movement in general, see Rice and Gowing (1989), and for later studio potters operating in Buckinghamshire including Mick Casson see Rotheroe (1966).

Finally, it may be noted that the pattern of common-edge location of most of the Buckinghamshire potteries is so evident that when a 'new' previously unrecorded pottery site is recognised, for example in Whittlewood Forest in the north of the county, or Ley Hill Common or Cadmore End in the Chilterns, it is no surprise to find that they occur on agriculturally marginal land. Although reliable documentation for the location of potteries only becomes available at a period when competition from outside the county is already leading to a reduction in their local importance, it seems unlikely that earlier potters were unaware of the resources that later potters utilised and, as suggested previously, it would be no surprise if future fieldwork demonstrates the existence of earlier production sites at locations where it is only documented at a later date.

#### ACKNOWLEDGEMENTS

The authors are indebted to a considerable number of people who have over the years contributed to this project including the following:

Many members of the former County Museum Archaeological Group; Ed Kendrick for providing an initial list of wills; Keith Bailey for providing a list of topographic names gleaned from early documents and maps; Brett Thorn at the County

Museum for collecting many boxes of sherds from storage, and Will Phillips also of the County Museum; a number of staff members of the Centre for Buckinghamshire Studies who have retrieved numerous documents, made a number of useful suggestions and helped with the interpretation of some texts; Hugh Hanley for drawing attention to the Stony Stratford inventories; David Noy for patiently translating several documents from medieval Latin; Richard Page, formerly of the Whittlewood Forest Research Project, and Paul Blinkhorn, for commenting on the Silverstone find; Christine Addison of Northants County Council's HER for information relating to South Northamptonshire; Julian Hunt for providing additional information about the Coleshill/Amersham area; the late Ian Rodger for information about potters in Brill; Shirley Blomfield and Chris Brown for commenting on the Buckland Common section; Michael Rice for providing information about Hedgerley; Miles Green about Penn, and Garry Marshall on Chesham. Ben Whitwell kindly agreed to allow his photograph of Mick Casson to be reproduced.

#### GAZETTEER

The gazetteer lists production sites from c.1200 until c.1910. As far as possible the entries are in order of parish, but as potters often operated on the margins of common land and such land was frequently shared by several parishes, boundaries between them are not always clear. This problem becomes fairly evident, for instance, with the potters of Penn, Coleshill and Winchmore Hill, who operated on the south and eastern margins of Wycombe Heath. Here the term 'Winchmore Hill', which is not a parish, seems sometimes to have been used as a general term for an industry lying in two if not three adjoining parishes. Sheahan (1862, 806) for instance noted that Winchmore 'consisted of a few cottages partly in Penn and partly in Amersham'. See Jefferys map of 1770 and Green (2013) for a discussion regarding the extent of the Heath. The same difficulty arises at Buckland, where there is a reasonable likelihood that the few 'Cholesbury' potters recorded may actually have been working in Buckland. There have been a number of changes to parish boundaries over the years, and where necessary old parish records have been cross-referenced to 'modern' parishes,

a number of which were created during the nineteenth century.

The authors have attempted to provide the names of the majority of potters working in an area. However, parish registers have not been systematically checked, and the advent of the ten-year censuses in 1841 has made this listing (as noted above) a more daunting task than was anticipated when the study commenced. In three cases; Amersham, the 'Beaconsfield Pottery' both in Chalfont St Peter, and Chesham, where large numbers of names are recorded, they have been moved to an Appendix to make the text more manageable.

Information on each parish is provided in up to three sections which roughly reflect the strength of the evidence available. The absence of a section means that there is no relevant information.

**Kilns:** This section may be preceded with some relevant background information about the parish. This is followed by a description of a pottery or kilns that can be clearly identified at a specific location e.g. on a printed or manuscript map, by excavation of all or part of a kiln, by the presence of 'waster' sherds (see above), or by any combination of these elements. A brief summary is given of the products and dates where available. The original sources cited should be consulted for further detail.

**Potters:** This lists the names of potters recorded to have worked in the parish. Where possible these have been linked to a kiln. They are given in approximate date sequence, except that on occasion, clear family entries are grouped together. Pot hawking becomes a common occupation in the nineteenth century and listed hawkers are included.

**Indicative Names:** Here local topographic names (e.g. fields) which might indicate the former presence of a potter in a parish are listed. Occasionally additional evidence will be available in the preceding sections.

The great majority of complete pots and pottery sherds referred to in the text are held by the Buckinghamshire County Museum, which should be consulted. Individual accession numbers are not always given here. The authors would be pleased to learn of any additions or corrections to this gazetteer.



### Abbreviations

BCM: Buckinghamshire County Museum referred to as ‘The County Museum’.

CBS: Centre for Buckinghamshire Studies, County Hall, Aylesbury, Buckinghamshire.

Ce: Census for the year quoted. In many cases the information has been obtained directly from the microfilmed copies of the census held at the CBS: however some use has also been made of transcripts and the website ‘Ancestry’ <http://wiz2.ancestry.co.uk/>

HER: Historic Environment Record. Records maintained by Buckinghamshire County Council, and for Milton Keynes by Milton Keynes Council.

All manuscripts referred to are held in the CBS, unless otherwise noted.

### Akeley

#### *Kilns*

There might have been a pottery in Akeley prior to the nineteenth century (see field name below) but the site has not so far been located. The enclosure map and award for Akeley cum Stockholt of 1794 (CBS: IR 72A) does show a ‘Kiln Close’ lying a short distance south-west of the village (plot

56) fronting its principal road and nearly a mile distant from the known nineteenth-century pottery (below), but no associated structures or extraction pits are shown. In 1980 one of us (BMH) did observe broken tile and vitrified brick while crossing the field but did not note sherds, so the ‘kiln’ name may relate to an earlier brickworks rather than a pottery.

‘Akeley Pottery’ is marked on the six-inch Ordnance Survey map of 1885 (1880 survey, sheet 13: SP 7140 3815) north of Duck End and adjoining a brickfield and kiln. Presumably this was also the site of the first Saunders establishment (below). The earlier enclosure map and award, previously noted, shows the same area simply as an allotment (plot 69) lacking structures of any kind.

The first potters recorded at Akeley are William and John Saunders in 1851. Aged respectively 28 and 30 years, so presumably brothers, both were born in Coleshill, a well-established pottery centre (below). It seems likely that they moved from there to establish the Akeley pottery, although a brief period by John Saunders in Maids Moreton is possible (below). A stamped rhubarb forcer of their era is illustrated (Fig. 3).

At a later date the business seems to have either integrated with, or to have run in parallel to, an



FIGURE 3 Top of a rhubarb forcer, stamped ‘Saunders Akeley Bucks’

adjoining brickyard run by Robert Watts. In the 1869 *Kellys*, Watts is first recorded as a brick and tile manufacturer, but by 1877 he has become a brick and tile manufacturer, *potter* and farmer, and continues as such (with intervals) until 1903. In an advertisement of 1886 (Fig. 4) T.R. Watts advertises flower pots, milk pans etc. as well as chimney pots, bricks etc (*The Liberal News and North Bucks Flying Post* 1886). Watts lived in the village at The Cedars (Hatton 1979, 24). He died on Jan 1<sup>st</sup> 1917 aged 84 and his tombstone is in Akeley churchyard. His working relationship to David Barton, listed in 1891, and Philip Mundy who is listed in 1895, is unclear.

A local resident (BFWI 1987, 9–10) records that: ‘Akeley also possessed a flourishing brickyard and pottery in the early part of the 19<sup>th</sup> century. This was owned by a Mr and Mrs Barton (below) who specialised in making flower pots, drain pipes for the building trade, and ornamental pedestals, bread bins and bricks etc. The clay was dug from a field at the back of the Pits, which used to have water at the bottom. The kiln stood for a number of years after the brickyard closed. The property was owned by a Mr Watts, who had a large house and orchard in the village where some of the ornamental bricks were used in the garden walls.’

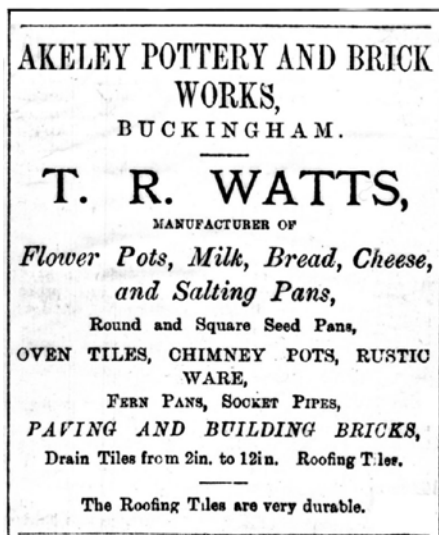

FIGURE 4 Advertisement of 1886 for the Akeley Pottery.

Writing in about 1910, J.M. Turner, the rector, noted that the brickyard and pottery had ‘long closed down’ (Turner c.1910, 36). A later sale catalogue of 1917 (D/WIG/2/6/411) respectively offers Lots 3 and 4 on the site as ‘Pottery House and brickfield’, and ‘Pottery Pasture Farm’. A sale catalogue of 1925 which covers a similar area confirms that ‘This property was for many years used by the late Mr TR Watts for brick, tile and pipe manufacture.’ Akeley History Group (2001, 53) records a memory of a bottle kiln at the site.

There is material from Akeley pottery in the Buckinghamshire County Museum and the Buckingham Old Goal Museum.

#### Potters

1851. William Saunders and John Saunders (Ce)  
1861. John Saunders (40) and his wife were living at ‘Potters House’ together with children also described as potters (aged 7 to 17!). William Saunders, also a potter, was living at The Cottage with his son Frederick (13). (Ce).  
1869. John Sanders potter (probably an error for Saunders, above) listed in *Kellys*.  
1871. John Saunders (27), ‘Brown ware manufacturer’, the son of John Saunders senior, living at The Pottery with one labourer (Ce).  
1877. Robert Watts, brick and tile manufacturer, potter and farmer. *Kellys*  
1881. James Blandford 1881, from Chilmark, Wilts. Lodged with Jesse Smith, brick-maker. (Ce)  
1881. David Benton potter (Ce). (Probably ‘Barton’ see below since both were born in Essex)  
1883. Robert Watts, brick and tile manufacturer, potter and farmer. *Kellys*  
1887. Robert Watts, ditto.  
1891. David Barton 1891 (47), red ware potter, and John Barton (18) probably his son. (Ce).  
1891. Robert Watts, potter and farmer. *Kellys*  
1895. Philip Mundy, 1895, potter, manufacturer of flower pots and pans etc. *Kellys*  
1903. Robert Watts, brickmaker and potter. *Kellys*

#### Indicative Names

An early eighteenth-century reference in Exchequer Records (*temp* Anne, 1702–1714) records ‘that part of Kingstropp called Potteres (*sic*) Hooke formerly

in the tenure of John Boughton.’ The field name has not been located. (Public Record Office staff kindly provided this extract, ref E 134/8 Anne, Mich.0). Also see ‘kilns’ above.

**Amersham** (including Winchmore Hill, Woodrow, Coleshill and Penn Street; for the latter see also Penn)

Amersham parish included a large area of the Chiltern upland extending southwards from the town to Wycombe Heath, which was shared with a number of other parishes and manors. In 1735, for instance, Amersham’s Court Book recorded an encroachment on ‘the lord’s waste at Wickham Heath’ and there are numerous later references of the same kind. The heath’s extent is shown on the maps of Jefferys (1770) and Bryant (1825) and the area is discussed by Hunt (2009, 38–40 and 2010, 22–5) and Green (2013).

The south-western limit of Amersham parish contained a number of common-edge hamlets including Coleshill, Woodrow, and Winchmore Hill, each of which had their own associated commons (IR/12.A.Q). Although Coleshill lay within the ecclesiastical parish of Amersham it has a complicated history, being a berewick of Tring and until 1844 a detached part of Hertfordshire with its own manorial history (Sheahan 1862, 806; Chenevix Trench 1973, 1977 and 1985). It became a civil parish in 1894 (Green 2000, 65). The ‘hamlet of Coleshill’ was focused on Coleshill Green which is only a little over a kilometre distant, east of Winchmore Hill.

The small but significant settlement at Winchmore Hill was bisected by the Buckinghamshire/Hertfordshire (Coleshill) boundary, on the west side of which lay Penn parish. Although superficially no more than a hamlet, Winchmore Hill originated as ‘a self-contained nuclear village in its own right with its own miniature field system’ (Chenevix Trench 1977, 415). The last surviving Buckinghamshire pottery was based at Winchmore Hill and the name became synonymous with the industry as a whole.

An additional geographic complication arises from the fact that a little over a kilometre north-west of Winchmore Hill is the hamlet called ‘Penn Street’ which lies in Penn parish, not Amersham. However, the name ‘Penn Street’ was also applied to at least part of the road leading west from Winchmore Hill in the direction of the hamlet

of the same name (Bryant 1825). This road crosses the Penn parish boundary which runs beside the buildings of Winchmore Hill. In 1798 a Job Carter is listed in the *Posse Comitatus* as a potter in Penn parish: however, in 1813 a Job Carter, potter, and presumably the same man, recorded in his will that he was of ‘Winchmore Hill in the hamlet of Coleshill, Herts’. It is possible that he could have potted at Penn Street (Penn parish) in 1798 and subsequently moved to the Winchmore Hill location, or he might have been misplaced in the *Posse*. A slightly different problem arises with placing potential ‘Penn Street’ potters when censuses that provide potters’ residential addresses become available. ‘Penn Street’ potters may indeed have been working at the hamlet but equally they may have been working at the Winchmore Hill pottery and living in cottages on the green here, which falls mainly in Penn parish! There was certainly one potter who was apparently working at Penn Street in the nineteenth century (see Penn), but further local research would be required to locate others who are provisionally included here under ‘Amersham’. The ‘Penn Street’ problem apart, there were two clearly defined areas of activity; around The Green at Coleshill and at the more loosely defined hamlet of Winchmore Hill.

The earliest date at which a clay worker of any kind is recorded in the area is in 1615, when a tile maker was working at Coleshill (Chenevix Trench 1985, 86, 96), although it is entirely possible that local clay sources were being exploited prior to this. The first potter to be recorded at Coleshill was in 1730. In 1861 the Slade family who had worked here for many years were still potting. The 1871 census is less clear on potting activity but Joseph Slade, probably the last of the dynasty, was in Amersham Workhouse. The earliest potter to be recorded at Winchmore Hill was in 1726. Probably the last potter to work here was Thomas Sears, who is reported to appear in a photograph of about 1910 (Hunt 2009).

The 2” to the mile OS surveyors’ drawings of c.1813 and the first edition 1” map (Fig 5) mark a ‘kiln’ on Coleshill Lane which can be located fairly precisely at SU 9364 9488. Hunt (2009, 50) attributes this site to the potters Robert and John Hailey. The first map of the area to specifically mark a pottery is Bryant’s 1825 county map which marks ‘Pottery’ adjacent to Winchmore Hill. As it is the only pottery that he records in the whole



FIGURE 5 Ordnance Survey 1" to the mile map of 1822 showing an early pottery site at Winchmore Hill, pre-dating the later and better-known pottery

county, this may indicate its significance as a centre at that time. The early 1" OS map of c.1822 (subject to some undated revisions) marks 'Potteries' at the Bryant location (which is different to the Hailey site noted above). The 1925 Ordnance Survey 25" map still marks 'Pottery' here (on the north side of the present Potters Arms) although by that date it may not still have been in operation. The pottery buildings have since been demolished.

#### *Kilns*

Although there is plentiful documentary evidence for potteries in the Coleshill-Winchmore Hill-Penn Street area, the map evidence, as noted above, is limited and no pottery kilns have been examined on the ground. Moreover, despite the late survival of the industry, the authors are aware of only one image of a kiln. This stood beside the house now called 'The Potter's Arms', the pottery referred to above. The picture (Fig. 6) is reproduced in Hunt (2009, 50) and Green (2000, 65) together with a photograph of its products (from Hunt 2009, figs

68 and 40). The kiln seems to be of the conventional bottle type with the addition of a detached freestanding chimney. Outside the pub are stacked a considerable number of earthenware vessels (Fig. 7). Hunt also includes an advertisement for J.E. Hobbs of 'Winchmore Hill Potteries' 'manufacturer of brown ware' listing his products, which include basic earthenware vessels for gardens, with seventeen sizes of flower pots, and also chimney pots, bricks, tiles and pipes (Hunt 2009, 75). Morley Davies (1912, 97) published a picture of one of the last remaining potters on his wheel at Winchmore Hill, who 'remembers seven kilns within a mile of the solitary remaining one at which he now works.' Hunt (2009, 51) says that the potter is Thomas Sears (Fig. 8). Sears was recorded in the 1891 census.

#### *Potters*

The Amersham Court Books (D/BASM/2/ 1 and 2) provide a good deal of information about the area, since potters were amongst those frequently encroaching on the lord's waste by erecting



FIGURE 6 Postcard view looking east towards ‘The Potters Arms’. The shape of a ‘bottle’ kiln can just be made out to the right of the chimney. ‘The Potters Arms’ is on the far right of the picture. The whole of the pottery works has since been demolished and built over

cottages or digging clay. The family names of potters working in the Winchmore Hill/Coleshill Green area recur frequently over decades, and it is evident that the potting tradition was commonly passed down through generations. Young family members are often recorded as potters in later censuses.

1686. William Bunce of Coleshill was party to a ‘conveyance of the house later known as the *Fleur de Lys Inn* [on the east side of Coleshill Green] (Hunt 2009, 50). By the 1730s the *Fleur de Lys* had been mortgaged to Mary Turner but was occupied by Richard Summersby who had a ten-year lease of a cottage and pot kiln (D/X/3/1). The name ‘Richard Summersby’ subsequently occurs in the court books up until 1793 when his will was proved: it seems likely that his son, or sons, may have had the same first name.
1726. Robert and John Hailey, potters, are

recorded when William Bovington of Penn insured two tenements at Winchmore Hill which they occupied together with a working shop, kiln house and stable. As previously noted, the Winchmore Hill settlement abutted the Buckinghamshire/Hertfordshire boundary, one part being in Amersham parish and the other in Penn (Green 2013, Fig. 2), which may account for William Bovington’s interest.

1733. The Amersham Court Books record two individuals, John Salter and John Dolphin, who had been digging clay on Coleshill Green: it is recorded that they would have to pay a fee for the privilege. The use to which they put the clay is not noted.
1734. William Cordwell (the younger), potter in the parish of Penn, Penn Street. His will was recorded in 1734 and proved in 1743 (78/98 and 84/241). See above for problems with ‘Penn Street’ location but this man

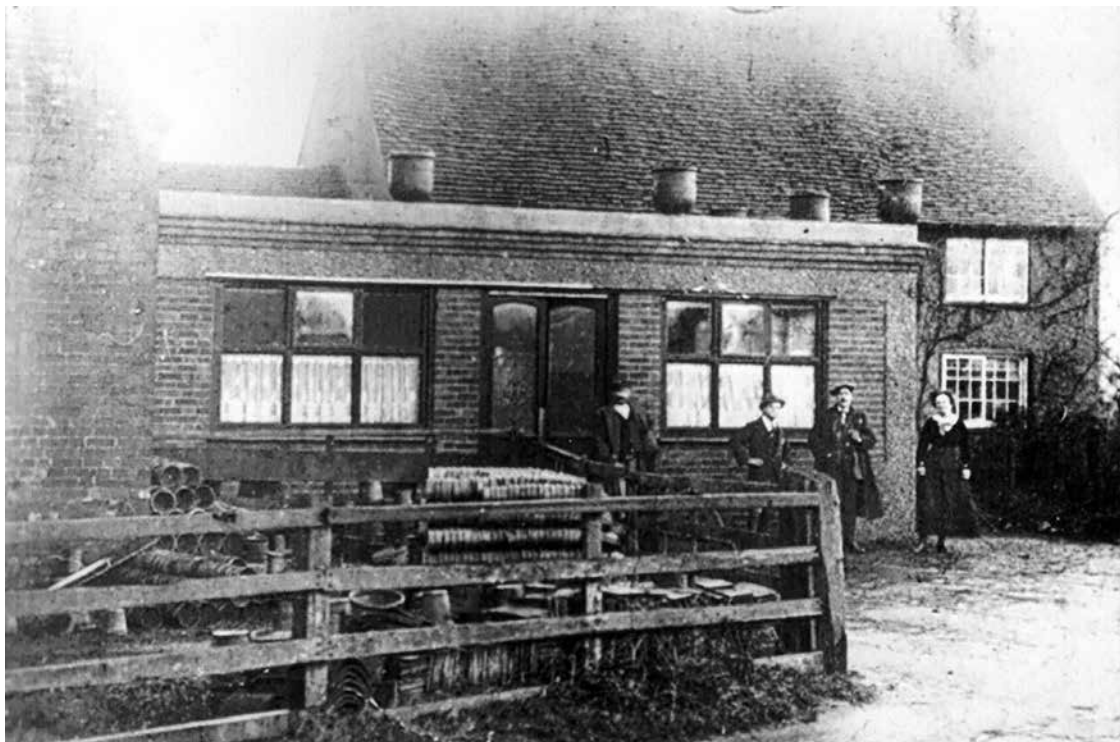

FIGURE 7 Photograph of 'The Potters Arms' with flowerpots for sale stacked outside

- may have been in the hamlet of Penn Street.
1735. The Court Book records clay-digging on Coleshill Green by four individuals, Thomas Rogers, Thomas Wood, Hoard Turpin and Richard Somorsly. Although the entry does not specify whether the clay was for pottery or brick and tile making, 'Richard *Somorsly*' is almost certainly the same person as Summersby the potter noted above and who continues to appear in court records as late as 1793. The clay diggers were to pay 12d a load in future (D/BASM/2/1). The fine appears in many later records of the Court Book. As Le Patourel (1968, 113) notes, a licence to extract clay would have been required whether it lay on the lord's land (commons, waste etc) or on the potter's own land.
1739. John Saltor and John Dolphin were recorded in the Court Book (see above) digging clay at Coleshill Green, but there is no record that they were potters.
1757. Richard, this time 'Sommersby' of Coleshill, appears again in the Court Book when the court regularised another encroachment on the Green; this time he had constructed a cottage.
1763. William Slade potter, Coleshill. Parish registers note his burial at Amersham (Anon nd).
1768. Richard Summersby, presumably the same person as above, appears in the Court Book for erecting a clay mill on Coleshill Green as does Edward Mowday, although the latter was at Winchmore Hill; he had also erected a hovel and pig sty (for Mowday see also 1770 and 1783 below).
1769. John Lane of Coleshill desired to 'be admitted to all that kiln, house ... shop or workhouse upon Coleshill Green'.
1770. Richard Summersby, Edward Mowday and Richard Rogers fined for clay digging on Coleshill Green (Court Book).
1781. Supplied by Richard Summersby to William Drake Esq. [Shardeloes] 'garden potts'. In the year, 16 dozen @ 2s 6d per dozen and



FIGURE 8 The last potter at Winchmore Hill, said to be Thomas Sears, photographed in 1909

- 27 dozen @ 1s 6d per dozen. Total bill £3.2s (D-DR/5/50).
1782. William Slade (presumably son of the deceased potter of the same name) occupies the building known as *Sansuns* the house 'wherein William Slade doth now dwells together with the pot kiln lately erected... at Coleshill in the parish of Amersham and county of Herts' (D/16/4/8). *Sansuns* later became the *The Potters Arms* at Winchmore Hill (Hunt 2009, 75) where there were a number of potters associated with the adjoining beer house. However, the earliest pottery that can be located at Winchmore Hill, in 1727, seems not to have been on the 'Potters Arms' site but on Coleshill Lane to the north of this site (see on 1813 and 1839).
1783. Will of Edward Moody [probably the same as Mowday above], potter of Coleshill in the county of Hertford. Prorogative Court of Canterbury (PRO: prob/11/1105). We are grateful to Julian Hunt for this reference.
1784. John Stent, Richard Summersby, Richard Rogers, Joseph Slade and John Ayres, fined for digging clay on Coleshill Green (Court Book) and Summersby is fined again for continuing use of his clay mill upon Coleshill Green (Court Book). There is also a reference to a kiln house and shop or workhouse.
1786. '[blank] Finch potter at Winchmore against [blank] Holding for ill usage. To appear at the Saracens Head, 13 March'. Recorded in the Justice's diary of Edmund Waller for March 1786. We are grateful to Roger Bettridge for this reference.
1786. Richard Summersby again fined for digging on Coleshill Green, but this time also fined are John Stent, Richard Rogers, William Oldham and Job Carter. The clay mills of Summersby and Oldham are recorded.
1791. William Pratley, Job Carter and William Carter, potters, occupied Benjamin Walker's property at Winchmore Hill, which he insured with Sun Fire (we are grateful to Julian Hunt for this reference: London Metropolitan Archive, Sun Fire, MS 11936/381/591979). The land included 'Pot Kiln Closes of Land' (D/16/4/9). Note that there were Pratleys (or Brackley) at Buckland.
1793. Richard Rogers of Amersham potter; marriage licence granted (D/AM R 530)
1793. Richard Summersby, potter, of the 'hamlet of Coleshill, in the parish of Amersham' had his will proved. He left to John Porter 'all my utensils and stock in my trade or business of a potter...[and]...all that my customary or copyhold cottage or tenement situate at Coleshill aforesaid wherein I now dwell together with the shop, drying house and kiln to the same.' (DAWE/ 117/19). In 1816 a John Porter was allotted land on Coleshill Green (Amersham Inclosure Award IR/12A plot 193)
1798. Job Carter (see above) and John Rogers, potters, are recorded in Penn Parish (see above) (Beckett 1985, 149).
1798. Thomas Godlyman, Robert Stratton and William Young, 'pot hawkers', are recorded at 'Amersham Woodrow', a hamlet roughly equidistant from Coleshill and Winchmore Hill (Beckett 1985, 134). They are the first

- of their trade to be recorded here, indicating perhaps that there was already a substantial production of ceramic in the area; by the mid-nineteenth century there were many more hawkers.
1799. Edward Ivory, potter, acquires *The Black Horse* on the south-east side of Coleshill Green. 'At the enclosure of Coleshill Green in 1816, Ivory was allotted two extra pieces of land near his house and kiln' (Hunt 2009, 69–70).
1813. Job Carter, potter of Winchmore Hill in the hamlet of Coleshill, Herts (previously noted), bequeaths to his son James '[property]...together with all my working tools that are in the working shop or elsewhere that belong to the shop and likewise my best horse and cart ...' (DAWE/129/49 and 112/107). The 1813 OS surveyor's map marks a kiln on Coleshill Lane, a short distance from Winchmore Hill (above). In the same year Priest (1813, 18), in describing Buckinghamshire brickearths, notes of Amersham: 'near which place this earth is very fine and supplies a manufactory of pots and pans.'
1816. Joseph Drake of Amersham potter, receives a marriage licence grant (D/AM D 429).
1816. The Amersham Inclosure Award (CBS IR/12A) shows a large triangular area of Winchmore Hill Common lying between the modern Nelson Close and 'The Hill' (on the Inclosure map called 'Winchmore Hill') and smaller areas on the east which are being allocated, none to known potters. There were also, however, unlisted 'Old Inclosures' here.
1819. Edward Ivory, potter, 'of the hamlet of Coleshill in the county of Hertford' (above) 'gives to John Page of Coleshill (blacksmith) and Charles George of Coleshill (shopkeeper) ... all those erections and buildings sometime since set up by me near my dwelling house at Coleshill Green consisting of a pot kiln and other buildings adjoining... and the residue whereof is occupied as and for a kiln yard...' (DAWE/132/125 and 113/235). Hunt (2009, 50) notes that this was on Coleshill Green.
1824. James Slade of Coleshill, presumably a descendant of William Slade who died in 1763, appears in an indenture acquiring a pot kiln from John Grove, gentleman (D/X/3/3). This was probably Lot 2 of a sale catalogue of the same date which lists at Coleshill Green 'land occupied as a kiln yard ... together with a pot kiln thereon' (also D/X/3/3).
1827. James Carter of Winchmore Hill (possibly a relative of Job Carter: see 1813 above), 'dealer in earthenware', brings a case in Quarter Sessions against William Lomath of Winslow, whom he alleges stole a washing pan and small pudding pan value 2/6 from Carter's cart whilst he was trading in Winslow. Lomath having been detained by the constable was held in Aylesbury goal. He was found not guilty (Justices case book QS/JC 6A, 136–7 and Calendar of Prisoners Q/SC/3/1). Although Carter describes himself as a dealer we know from his father's will (1813 above) that a James Carter, presumably the same person, had inherited his father's pottery business as well as his horse and cart; making and trading may not have been completely separate traditions. The later Amersham tithe map of 1839 (CBS Tithe 9) shows a James Carter occupying plot '1117 Cottage, garden and kiln'. This was north of Coleshill Lane at Winchmore Hill, whereas the Sansuns kiln was south (see on).
1831. William Carter, potter, of Penn Street succeeds in a case against Charles Moorcroft who stole 4 earthenware pans value 1/-, 3 earthenware pitchers value 7d, 2 dishes value 6d. John Ropers who works for Carter was a witness (QS/JC/13).
1834. James Slade who lived in Coleshill had 'the freehold of a pot kiln' which was occupied by Thomas Slade (CBS PB/R/2)
1839. Coleshill Green. The Amersham tithe map (CBS Tithe 9) shows that James Slade had some 12 acres for clay pits on The Green (plot 1076); this was a substantial part of the Green (later The Common). It remains as a well-dug-over sloping piece of land. His cottage, garden and kiln were on the east side of the Green (plot 995a) adjacent to the cottage of John Slade. Two other cottages adjoining the Green on the east were also held by a 'John Slade'. William Slade held



- the ‘Lower Pottery’ (plot 1198) which was a short distance downhill. Surprisingly he is not named in the 1841 census. East of most of the Slade holdings was Pot Kiln Meadow (plot 993) under grass.
1839. Winchmore Hill. The Amersham tithe map records only one potter here (plot 1117), James Carter (see 1827 above) who had a cottage and kiln on a site between Hill Road and Coleshill Lane, now occupied by *The Plough*. Sarah Walker owned this land but herself had a cottage a little further south facing the common (plot 1119). At a slightly later date Walker’s site was occupied by Winchmore Hill’s principal pottery adjacent to and behind the present *Potters Arms*. The latter appears in photographs and is shown e.g. on the 1925 edition OS map. It is possible that Carter’s pottery could have been on the Potters Arms site and had been mapped at an incorrect location on the tithe map, but east of The Plough site fronting Coleshill Lane is Clay Pit Wood (1113) which was probably its clay source, so the Potters Arms site may represent a new business on this site. Not far to the east of the latter was Potters Meadow (plot 1123). It may be noted that in 1841 a James Carter was recorded as a pot hawker (see below), so perhaps Carter’s business had folded by that date.
1841. Census (see Appendix). At least eighteen potters are now recorded in the area, including those who may have been at Penn Street. Notably there are ten ‘pot hawkers’. The Slade family appear to be the most important potters at Coleshill Green, where there was also the largest number of potters.
1842. James Slade is listed as an earthenware manufacturer in *Pigots Directory*
1846. James Slade, potter, Amersham, had his will proved (D/A/we/144/69). He left a freehold pot kiln to his wife Sarah to pass to his son Job. A memorandum confirms that Job Slade, potter of Coleshill, had indeed acquired the freehold kiln from his father (D/X/3/3). Among the same bundle of papers is an indenture of 1850 referring to Job as a potter. James Slade also had a son called George, and it may be noted that two potters who were born in Coleshill, George Slade and John Sears, were potting at Adderbury (near Banbury, Oxon) in the 1840s. They had left there by the 1870s (Stebbing *et al* 1980, 8, 25). Slade’s daughter was married to Samuel Sears, possibly the potter recorded at Lane End. The 1851 census (below) shows that although Job had acquired the freehold, Sarah his mother had continued in the business.
1851. Census (see Appendix for detail). Job Slade of Coleshill Green now emerges as ‘head potter’ with Sarah Slade, his mother, as a ‘pot manufacturer with five labourers’ but John Saunders also appears to have an establishment here. In 1841 there was a 74-year-old Pratley who is no longer listed but other Pratleys, presumably relatives, headed by Emmanuel, have appeared at Winchmore Hill. Emmanuel was born in Wheatley, Oxon, not far from the Nettlebed potteries, but significantly his children were born in Buckland where the surname is recorded, so he probably moved here from Buckland on his relative’s death. In the 1853 directory (below) he doubled up as a beer retailer, apparently establishing the link between the pottery and the adjacent ‘Potters Arms’. Joseph Drake had earlier migrated to Winchmore Hill from another pottery centre, Farnham in Surrey. There are roughly the same number of potters at Coleshill as there are at Winchmore Hill. The number of recorded pot hawkers has diminished.
1853. *Musson and Cravens Directory* records Emanuel Pratley as beer retailer and earthenware manufacturer at Winchmore Hill. [NB previously just a potter]. This would have been (and remains) The Potters Arms (previously Sansuns; see Hunt 2009, 75). The same directory notes Arthur Clarke in Amersham High Street who was dealing in various items including ‘china, glass and earthenware’.
1854. *Kellys* has separate entries for Winchmore Hill, Coleshill and Penn Street. Subsequently the location ‘Winchmore Hill’ is dropped (and apparently subsumed within Coleshill) but entries for Penn Street continue (see Penn). Under Coleshill it states ‘The trade is that of manufacturing earthenware pots and pans’.

1854. William Carter, brick maker, potter and farmer [He appears under both Coleshill/Winchmore Hill and Penn Street in *Kellys*, but other information places him at Penn Street Farm]. *Kellys*.
1854. Emanuel Pratley, potter and beer retailer, Winchmore Hill. *Kellys*.
1854. Job Slade, earthenware manufacturer, Coleshill. *Kellys*.
1861. Census (see Appendix). John Saunders, earthenware potter, employs one labourer and three boys at Coleshill and there are still several Slades working there. Emmanuel Pratley seems to have left Winchmore Hill and it is likely that he had had been replaced by John Toovey as both 'pot manufacturer' and beer retailer. Fourteen pot hawkers are now listed.
1862. Sheahan (1862, 806) writes of Coleshill hamlet 'The manufacture of coarse pottery has been immemorially established at Coleshill, and there is one establishment for making earthenware pots and pans' Of Winchmore Hill, as a sub-entry, he notes 'Here are two potteries.'
1864. Job Slade, earthenware manufacturer, Coleshill. *Kellys*.
1865. George Reading, earthenware manufacturer, Coleshill (*Cassey's Directory*). A George Reading(s) was working in Oxfordshire in 1861 (see Introduction) and in 1871 an Allen Reading, possibly his grandson (1871 census), and then at the Potters Arms [Winchmore Hill] was born at Nettlebed, Oxfordshire: it is likely that this was the same family.
1869. Allen Reading, beer retailer and potter, Coleshill. *Kellys*. Also 'The trade is that of manufacturing earthenware pots and pans'.
1871. Census (see Appendix). It appears that the pottery business at Coleshill was still operating at Coleshill, probably under the control of William Sheperdley with labourers including one Slade, but place of residence by this date seem even less likely to reflect workplace. The Potters Arms at Winchmore Hill was now apparently run by Allen Reading with his son and Thomas Sears, and one other. Notably there were still eight active pot hawkers in the area.
1874. Benjamin Brickwill, surgeon, had leased the Potters Arms at Winchmore Hill in the occupation of Alfred Reading, beer retailer and potter, to Wheelers Brewery of High Wycombe.' (Hunt 2009, 75: D 147/32/102).
1877. Alan Reading, Coleshill, beer retailer and potter, and a second Allen Reading at Penn Street, also a potter (*Kellys*). The census shows that this was his son. *Kellys* also notes of Coleshill that 'the trade is of manufacturing earthenware pots and pans'.
1881. Census (see Appendix). By this date no potters seem to have been based at Coleshill Green (but see below). The Winchmore Hill pottery continues on a fairly small scale in association with the Potters Arms, but is now run by John Saunders, who was previously potting at Akeley. Only two pot hawkers and a dealer were still in business in the area.
1883. Thomas Saunders, beer retailer and potter (*Kellys*). *Kellys* also notes of Coleshill 'The trade of manufacturing earthenware pots and pans was formerly carried on here, but now is nearly extant, there being only one kiln.'
1883. Alan Reading, beer retailer and potter, Penn Street (*Kellys*), see 1877. It is not clear where he was based, but he seems to have previously departed from the Potters Arms
- c.1887. Saunders had been succeeded at The Potter's Arms by William Hobbs, whose family eventually purchased the freehold of the pub (Hunt 2009, 75). The 1887 *Kellys* lists him as 'beer retailer and potter, Coleshill'. *Kellys* also notes Thomas Saunders and William Hobbs as potters at Coleshill and Allen Redding at Penn street (*sic*). The reference to there being 'only one kiln' (see 1883) is repeated.
- 'William Hobbs was succeeded by Joseph Hobbs. His widow was still running the pub in 1920.' (Hunt 2009, 75).
1891. Census. See Appendix. Joseph Hobbs now ran the Winchmore Hill pottery and the pub. He had five potters working with him, so business was obviously flourishing.
1891. Allen 'Redding' appears as a beer retailer and potter in *Kellys* still at Penn street (*sic*).
1891. Joseph Hobbs & sons beer retailers and potters, Coleshill (*Kellys*). In the trade section there is a potter Joseph Hobbs and

son, at Penn. This is probably a confusion about place. Hobbs and Son continue to appear in *Kellys* for several years.

- c.1920. Advertisement and price list for J.E. Hobbs at ‘Winchmore Hill Potteries’
1922. Sherlock and Noble (1922, 46) record similar products to those listed in the advertisement: ‘Flower pots, drain pipes and red bricks are made from Reading Beds at Winchmore Hill near Amersham.’ The 1922 publication date would of course be subsequent to their survey of the area. As previously noted, the 1925 25” OS map still marks the pottery.

#### *Indicative Names*

1787. Great Potters Croft with Little Potters Croft, Amersham (D-CH/A/3-4 fol. 4). Probably part of Abbotts Farm, Woodside.
1839. Amersham tithe map. Plot 1125 Potters Field, arable, occupier Thomas Bovingdon. This abuts Coleshill Lane and relates to a kiln site identifiable on the surveyor’s 2” OS map (see introduction), and see 1726 entry.

**Aston Clinton** (see Buckland)

#### **Aylesbury**

##### *Indicative Names*

A sale catalogue and plan of 1806 entitled ‘Freehold and Copyhold lands and Brick Kiln’ in Aylesbury, describes Lot V as ‘bounded partly by Crokham Leys’. Lot V (E on plan), which fronts Cambridge Street/Bierton Road. The lot lies in an area now occupied by a prison and adjacent to the Victorian ‘Manor House’. The likelihood that the ‘Crokham’ field name may indicate an early pottery in the area is increased by the presence of workable clay nearby described as an ‘head of excellent brick earth’ (CBS: D/LO/4/27).

#### **Beaconsfield**

For ‘Beaconsfield Pottery’ see Chalfont St Peter.

#### **Boarstall** (and see Brill)

##### *Kilns*

The discovery of pottery wasters at a number of locations in Boarstall was reported in Farley

(1982b). Subsequently, other surface finds of wasters have been recovered (Fig. 9), including some located before construction of a golf course to the south of the village (HER 5233 and 6325). Decorated jugs appear to have been a speciality of Boarstall but other forms included jars and pipkins; the full range of products has not been studied in detail. The initial finds were dated to the thirteenth-fourteenth centuries. The area also produced decorated floor tiles on which a report is being prepared.

In 2008 an archaeological evaluation at Village Farm located traces of a kiln or kilns which utilised tile, small bricks and possibly limestone in its structure, and was associated with burnt clay (Milbank 2008). The pottery, which included wasters, appears to be of fifteenth-century date, extending the date of the industry here. Grey clay noted in all the trenches during the evaluation was probably the source for the industry.

##### *Potters*

As Brill and Boarstall were neighbours within Bernwood Forest the documentary evidence can be difficult to separate, particularly as most of Boarstall’s land was held of Brill manor (Salter 1930, 65–66). Of the remaining land, some was a separate manor of the forest serjeantry. The clearest documentary evidence for early potters here occurs in the *Rotuli Hundredorum* (I, folio 22a) in 1254–5 (see also Brill), when under the manor of Brill it was recorded that Roger Segrim of Boarstall ‘has one oven and gives the lord King 3d’. Given the field evidence above it seems probable that his kiln was at Boarstall.

In 1307 a Thomas le Porter appears as a witness, probably at Boarstall (Salter 1930, no 458), and in 1369 a Thomas Porter grants substantial land to Henry Porter of Oxford (Salter 1930, no 389). In 1384 ‘Porterysplace’ is recorded. An inquest held at Boarstall in 1389 included amongst the jurors John Pottere (Boatwright 1994, no 230) and in 1408 a ‘Potteris place’ is recorded (Salter 1930, no 398). A John Potter occurs again in 1415 (Salter 1930, no. 448). It could be that all of these fourteenth-century ‘Potter’ and ‘Porter’ names are successor families to the earlier potters active here.

##### *Indicative Names*

We are grateful to Maureen Mellor for pointing out the name ‘Potters Close’ on a map of 1641 on the



FIGURE 9 Medieval jug sherds from a fieldwalk at Boarstall

outskirts of Studley, Oxon, immediately adjoining the Buckinghamshire county border and two kilometres south-west of Boarstall (VCH Oxon V, reconstructed map 65). Within Boarstall parish there are 'Potters Leas' and 'Little Potters Lees' north-west of Lower Panshill Farm, but a brief field inspection did not reveal any surface pottery here.

**Brickhill** (see Great and Little)

**Brill** (and see Boarstall)

Brill's main claim to fame arises from the presence of a king's house here. The house had probably been established by the reign of Edward the Confessor, principally as a base for hunting in the Forest of Bernwood. However, from the twelfth century if not earlier, Brill's clay industries played an important part in village life. Indirect royal patronage may have helped them to flourish in conjunction with availability of good potting clay, fuel, and access to the nearby towns of Bicester, Thame and, in particular, Oxford.

Lipscomb (1847, I, 96) quotes Kennett, a late seventeenth-century local author who notes that at Brill '...the earth within serving for the best brick and earthen vessels, and the stones for lime'. Lipscomb himself (*ibid*, 107) has an interesting comment, implying some early archaeological deduction (albeit reaching the wrong conclusion!):

'The natural productions of the soil of the hill have immemorially employed many of the inhabitants of Brill, and from the number of fragments of ancient pottery bearing a close resemblance to that of the Romanized Britons, found in the neighbourhood, it may be fairly conjectured, that, even at that early period, a manufactory of this description was established here.'

During the medieval period Brill's products were traded over a large area. The stores of the Ashmolean Museum, for example, contain many Brill pots excavated within Oxford (see Mellor 1994 and 1997 for a wide range of examples), and potting continued at Brill until the mid-nineteenth century. It was the longest-lived pottery centre in

the county and probably the region. There was also an early and long-lived brick and tile industry here which is not dealt with in this article.

Most early Buckinghamshire pottery production sites have no documentation, but for the medieval period in Brill there are potter's names as well as records of kilns and of manorial dues paid for clay extraction. Pots were also produced in the medieval period at the adjoining village of Boarstall (above) and the industry is now known to archaeologists as the 'Brill-Boarstall' industry. In recent years evidence for possible production at the nearby village of Ludgershall has also come to light (below).

The earliest reference to potters at Brill occurs in a land transaction of c.1210–20 recorded in the Boarstall Cartulary, which was assembled in the fifteenth century by Edward Rede, the occupier of what today is known as Boarstall Tower. Here it is noted that of a certain three acres at Brill, one was held by Sampson le Potter and another by Walter le Poter (Salter 1930, no 209). A little later in the *Rotuli Hundredorum* of 1254–5 (I, folio 22a), there are references to what are clearly potters' kilns entered under the manor of Brill:

'Concerning the oven [*rogo*] we say nothing. Concerning the ovens [*furnis*] we say that ten furnaces or their places are on the fee of the lord king and on the fee of John son of Nigel from which the lord king takes annually rent and service. And we say that the Abbot of Oseney, the Abbess of Godstow, the Prior of St Frideswides and the brothers of the hospital of St Bartholomew outside Oxford have their woods adjoining the field [fields] of Boarstall from which each has two carts carrying their firewood on each day through the year and from small branches of the residue of the carts we understand that much are the potters sustained and sometimes they steal sometimes they are attached and the attachment impleaded in the swainmote for the benefit of the lord king'.

A separate entry in the *Rotuli* (I, folio 26b) also relating to the manor notes:

'Concerning the oven [*furno*] for making pots they say that Peter of Brill has an oven, he gives to the lord king 3d per year. Roger Segrim of Boarstall has one oven and gives the lord King 3d. Likewise John has an oven and John Alan together they have a wood for their ovens from their acquisition and nothing from the king's demesne of sale or of gift but they have their own boys and

others and they collect through the demesne woods loppings and branches for their hearth [*focum*] ... [text defective]...and there are more ovens but they do not know the names of the tenants of those ovens.'

The authors are most grateful to David Noy for these translations.

In 1297 one Bartholomew quit-claims a tenement to Roger his son and his wife Juliana, daughter of Robert Pot. The tenement lies adjacent to a tenement 'lately of Bartholomew *turnetor*' (Anon c.1939, deeds 1603 and 1604). It is likely that a later deed of 1413 referring to 'Turnour's Croft (deed 1629) also relates to Bartholomew's Croft, in which case it appears to lie on the 'lane leading from Brill to Dorton', an area where no kilns have been recorded. Between 1314–17 the receipts from Brill manor included a yearly amount of 4s 6d from 'Claygavel' (Salter 1930, no. 629) and VCH notes other regular payments in the steward's accounts of the thirteenth and fourteenth centuries (VCH 2, 50, 115). As previously mentioned, Brill's medieval products were widely traded. A selection of Brill jugs found in Aylesbury is illustrated here (Fig. 10) and a face-sherd from Missenden Abbey (Fig. 11).

Rights within Bernwood Forest within which Brill lay were a cause of dispute over several centuries. Eventually, in 1623 a commission was issued for the final disafforestation (VCH 2, 137) and the process had been implemented by 1632: '... its staff were compensated, the remaining crown lands sold. The timber cover had largely gone by 1635' (Hoyle 1997, 55). The whole process completed a sustained period of enclosure and removed common rights from many areas, which would have had a direct effect on clay workers and the supply of their raw materials, in particular wood. However, there was some protection for them, as an order in Chancery ensured that 18 acres of the King's land and 30 acres of Sir John Dynham's were provided for the 'many artificers of Brill [who had] received employment by making brick, tyle, lyme and potts out of the soyle of Brill hills' (Lipscomb 1847, 107). By the late seventeenth century 'The brick and pottery trade, based on the right to extract clay from the common land on Brill Hills at a fixed rent, was slowly declining. There were only five kilns paying rent in 1682, only two a hundred years later.' (Broad 1997, 102). The right is still noted in the 1853 tithe award (plot 509) where 49 acres 'now commonly called



FIGURE 10 Medieval jugs made at Brill but found elsewhere. Clockwise from top left: Buckingham Street, Aylesbury; George Street, Aylesbury; Prebendal, Aylesbury, and George Street, Aylesbury. All in the County Museum.



FIGURE 11 Brill jug rim with applied faces, from excavations at Missenden Abbey

Brill Common' are recorded as belonging to the occupiers 'The artificers of Buck. tile lime and pots ancient cottages and poorer sort of inhabitants of Brill and the Lord of the Manor.' A few years earlier Lipscomb (1847. I, 107) noted: 'The pottery is still carried on, but the trade is not in a flourishing state, the condition of the roads, increased price of fuel, and expenses of carriage, having co-operated to its disadvantage.'

The names of a number of Brill potters are known (below) and the residences of some of them, but at the moment the only certain match between an excavated kiln and a potter is of a kiln belonging to the Hubbocks family. The name is first recorded in 1766 (below), and the family continued to work as potters through the nineteenth century. Sheahan (1862, 339–40) is probably referring to the Hubbocks family when he notes 'there is only one small pottery here for the manufacture of brown earthenwares'. The last member of the Hubbocks family to work as a potter retired in about 1875. VCH (1908, 115) notes that his kiln was still standing, and that he had 'made for the most part flower-pots and large pans and jugs, one or two of which are to be seen at Brill, but they bear no date since he only dated his pots at the request of the customer. His stock was bought up some years ago "for a museum in Oxford". Their

last kiln was at the top of Tram Hill and was partly excavated in 1975.

Three inscribed pots from Brill, all in the County Museum, are known (Farley & Hurman 1978). One, dated [17]64', has the words 'John Shiperle pter Brill Bux' on its base (Fig. 12). The vessel is referred to in VCH (1908, II, 114–5), although the surname has there been misread as 'Sheperde'. The second pot, a substantial lidded storage jar with a very small bunghole or drainhole, has on the front 'Thomas Hubbocks Brill 1791' and on the lid 'TH 1791' (Fig. 13). The third, a 'lampstand', has 'THB 1861' on its base (Fig. 14) and is recorded to have been 'made in the brickyard at Brill', presumably by Thomas Hubbocks. Both surnames appear in other records. In addition the County Museum has an incomplete earthenware pipe (probably for a drain) which has painted on it in white slip 'Phillip Sch...[broken] Brill 1766' (Fig. 15). This is almost certainly Philip Scholey (below).

This study does not include brickmakers but it is clear that brickmakers occasionally had a sideline in pottery production. This is most evident in the fabric of late Brill pottery which is not far removed from brick-clay (e.g. Farley & Hurman 1978). A bracket shaped in the form of a lion's foot from Brill in the same material, said to have been made before 1870, is in the County Museum collection (1932.7.1). Writing in 1912, Morley Davies notes of Brill, 'just as the pottery industry was dying out, the brick industry developed through the opening of railway communications with London [no doubt initially via The Brill Tramway]. The bricks are now made from clays rather lower in the geological scale and less sandy than those from which pottery was formerly made – Kimmeridge Clay at Brill.'

Most of the pottery kilns that have been investigated in Brill have been close to the village centre, and were recorded either beneath standing buildings or in former gardens during alterations or development. Judging from the presence of infilled pits found during these investigations, some clay at least appears to have been dug within the yards of the potter's dwellings and workshops on the hilltop. The highest layer of clay on the hill lies a little below the thin intermittent layer of sand and ironstone which caps it. The same bed would also have outcropped at the northern edge of the village where the first medieval kilns to be investigated were excavated by Jope and Ivens (below). During the medieval period potting clay



FIGURE 12 Base of a vessel made by John Shipperle. The front of the pot has the date 1764 on the front (insert)

FIGURE 13 Substantial jar or cistern made by Thomas Hubbocks, with his name and the date 1791 on the front, and his initials on the lid with the date repeated







FIGURE 14 'Lampstand' collected in Brill with 'THB 1861' on its base (Thomas Hubbocks, Brill: see Farley & Hurman 1978)

FIGURE 15 Earthenware pipe from Brill with Philip Scholey's name and the date 1766



might have also been dug, and possibly fired, lower down the hill on the adjacent common, but direct evidence for early workings here are likely to have been removed by the extraction of large quantities of clay for the production of bricks and tiles, which came to dominate the industry by the nineteenth century. It is the brick kilns which are shown on a number of nineteenth-century maps and on a splendid oil painting in the County Museum by John Niemann, dated 1858. Former workings are still very evident on the north and west of the village today.

### *Kilns*

There have been several archaeological investigations at Brill: they are listed below by date of publication.

a) Jope (1945). Surface finds of pottery wasters were recorded in a black, ashy soil. Pottery included jugs, pans and cooking pots, dated to the fourteenth cent. Further investigations were planned (see below).

b) Jope (1953–4). Preliminary report on excavations in 1953 at Temple Farm, Tram Hill. Three superimposed double-stoke hole kilns were excavated, roughly built of broken stone and sherds. A fourth kiln at a distance was also investigated. This was better built, of tile with ‘stoke flue arches of specially shaped bricks’. Dating: late thirteenth to early fourteenth century. The kiln produced cooking pots, pans, handled skillets, oval herring dishes and glazed jugs (Fig. 16). Jope did not himself produce a final report on this site, although pottery from the excavation was subsequently published by Jope and Ivens (1981, below). Interestingly, a short account of the excavation appeared in *The Times* in 1953. It was written in August 31<sup>st</sup> by ‘Our own correspondent, Oxford’, and it was noted that ‘Among the hundredweights of pottery remains were a number of almost complete pots...’ One suspects that the ‘correspondent’ was Jope himself. [HER 0576, 04394, 05678] (Fig. 17)

c) Aitken and Weaver (1962, 11 & 21), carried out archaeomagnetic dating on two kilns; Brill D, one of Jope’s kilns, and Kiln E, an additional kiln they



FIGURE 16 Late thirteenth to fourteenth-century pottery from Jope’s excavations at Temple Farm, Brill

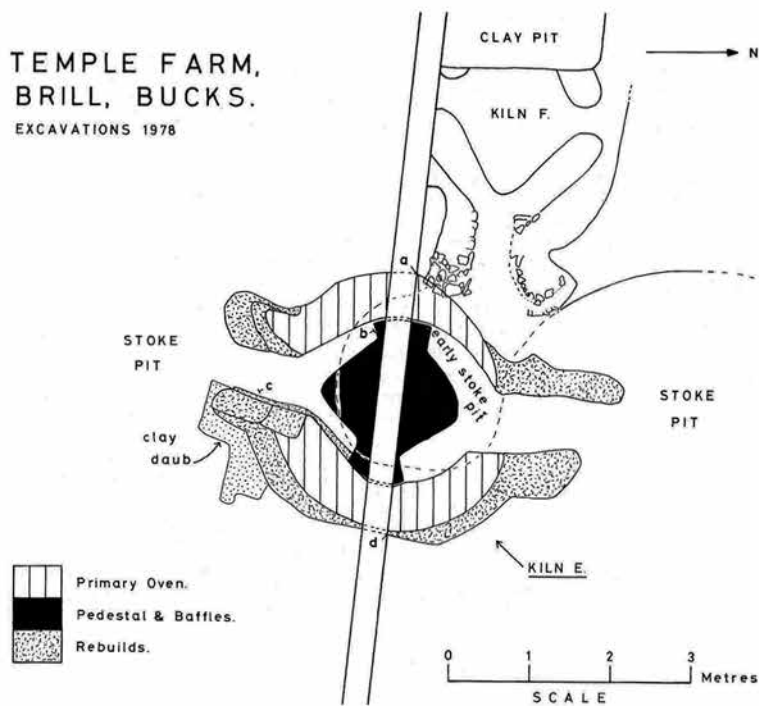
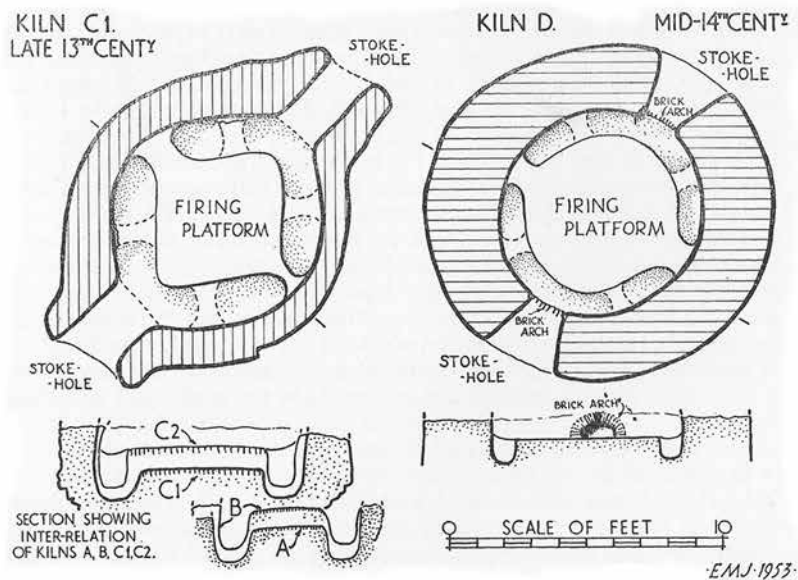

FIGURE 17 Plans of medieval pottery kilns at Temple Farm, Brill, excavated by M. Jope and R.J. Ivens (from Jope 1953–4 and Ivens 1981)

had discovered during geophysical survey. Kiln E was 'producing wares very similar to those from kiln D'. The excavators provide a reference 'M.G. Tite & G. Weaver unpublished' but their investigation of Kiln E never did appear in print. Kilns D and E produced dates of 1300–1350 (see also Sturdy & Case 1961/2).

d) Three separate investigations are described in Farley (1979):

(i) In 1974 A sub-square brick-built kiln was discovered in Windmill Street. It was apparently multi-flued but there was only a small exposure during building works (Fig. 18). The main products were bowls and large jars with a few jugs. Subsidiary products included dishes, 'chamber pots', cups (?), chafing dishes and costrels. A green-brown glaze was used sparingly. Several saggars (for containing smaller glazed vessels) were found but no

certain examples of the products which would have been associated with them, although this would probably have been cups or tygs. The kiln was provisionally dated to the early seventeenth century but is now thought to be sixteenth century (Blinkhorn *in* Williams 2010). [HER 02129]

(ii) In 1975 during house construction at the top of Tram Hill, two burnt hollows (A & B), containing quantities of seventeenth-century pottery, were discovered. The hollows were thought to have been the stoke holes of kilns, possibly brick-built but utilising also peg tiles. Both contained similar wares including bowls, chamber pots, baking dishes, warming pans, costrels, jugs and tygs. [HER 02235]

(iii) On the same Tram Hill site as above, known locally as The Clay Sheds, the base of a circular brick-built kiln was uncovered in a footing trench (Fig. 19). It proved to be Brill's last working



FIGURE 18 Part of a sixteenth-century kiln discovered during construction of a garage in Brill in 1974. One flue is visible to the right

pottery kiln and belonged to the Hubbocks family (below), the last potter being Henry Hubbocks. The kiln was still standing in c.1908. It had an internal diameter of just under two metres. The only visible firing point had a fire-brick grating, level with the floor of the chamber. There were indications of an opposing firing point but no direct evidence for the enclosing 'hovel' which gave most such kilns the characteristic 'bottle' form common in The Potteries. A photograph of another kiln of circular form with protruding ground-level arches sited on the edge of the common at Brill, would give a plan form matching that of the Hubbock's Tram Hill kiln (Fig. 20: from Prosser 1999, 95).

Much secondary material had been dumped in the firing chamber. The only products which could with some confidence be associated with the kiln were bowls/dishes and a straight-sided flower pot form. An occasional distinctive

feature was the presence of an internal white slip with splodges of green. Decorative slip seems to be a relatively uncommon feature of later Brill wares.

(e) In 1976 Mrs J. Strong collected medieval sherds, including several wasters, from an allotment at the southern end of the village (SP 655 137: HER 2478). Apart from this discovery, all the medieval production areas identified so far are at the northern end of the village. Presuming that the material found here was *in situ*, a further distinct area of production is indicated. [HER 02478]

f) Ivens (1981). In 1978 Ivens carried out a small excavation to relocate and describe more fully the Tite and Weaver Kiln E (above). He also located other previously unexcavated kilns through geophysical survey. Kiln E was found to partly seal the stoke pit of an earlier kiln (Kiln F). A report on



FIGURE 19 Kiln discovered in 1975 in the footing trenches of a house at the top of Tram Hill, Brill. The insert shows the fire grate visible on the floor of the trench. The kiln belonged to the Hubbocks family, and was probably the last working pottery kiln in the village

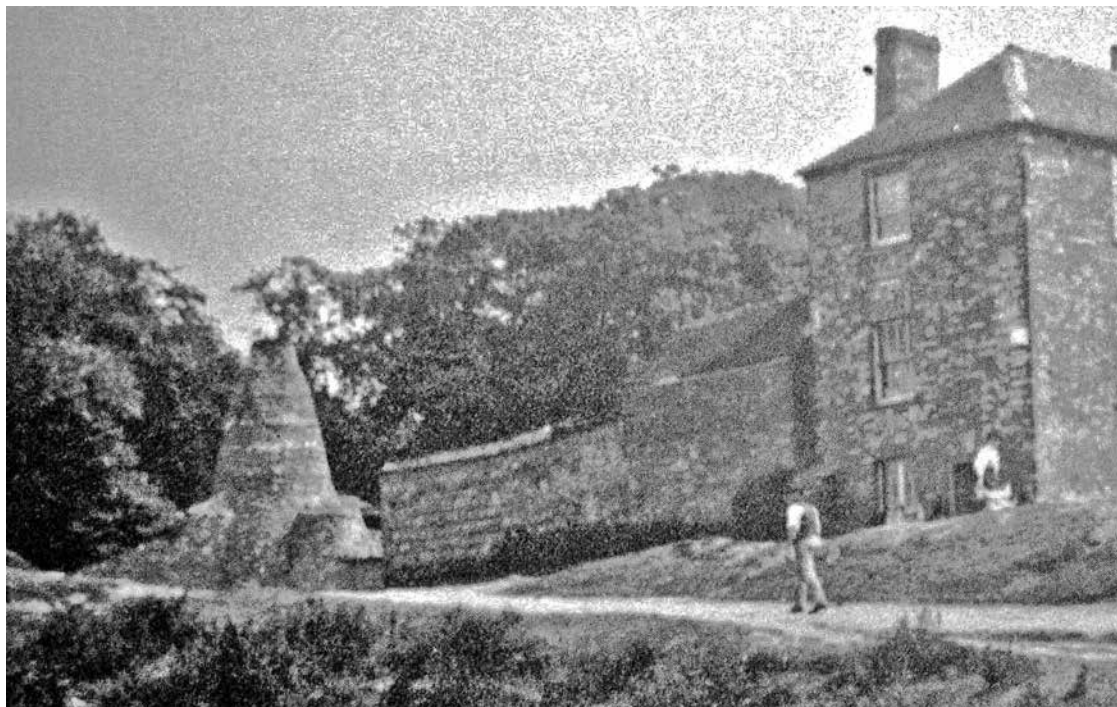

FIGURE 20 'Bottle kiln' on the edge of Brill Common (from Prosser 1999)

the pottery from the excavation of Kilns E and F is to be found in Ivens (1982). Figure 17 shows plans of the kilns excavated by Jope and Ivens.

g) Jope & Ivens (1981). The authors report on an aspect of the original excavation by Jope (1953–4, Kilns A-D). They describe a type of ware untypical of later Brill products, and which could be demonstrated to be stratigraphically earlier in date. The ware, some of which was in waster form, contained many inclusions including flint/chert and limestone. All the vessels appear to have been large storage/cooking vessels, often with a thin internal lead glaze. A date in the mid-thirteenth century is proposed.

h) Ivens (1982). Several hundredweight of sherds were recovered from the 1978 re-examination of Kilns E and F by Ivens. The most common forms present were jugs, cooking pots, pancheons, skillets and pipkins. Rarer forms included small dishes, a louver and part of a blowing horn (for the latter type see Le Patourel 1992, 158–160). Three fabrics were recorded, the most gritted

being used for cooking pots, a moderately gritted fabric for standard jugs and a fine smooth fabric for finer ornate jugs, of which only a few sherds were present. Jugs, bowls, pans and skillets were normally glazed; glazing on cooking pots was uncommon. Slip was occasionally used for decoration and a range of other simple line or stab decoration was occasionally present, as well as e.g. rouletting. The material is dated later thirteenth to mid-fourteenth century.

i) Cocroft (1985). Two kilns were discovered in Prosser's Yard, Temple Street, when it was being developed for housing in 1977. Kiln 1, brick fronted, was sunk nearly 2.5m into the ground. Circumstances severely constrained the investigation and the kiln's interior was not accessible. At the base of its front wall was a flue arch and above this near the top of the wall was a niche containing a complete glazed cup that had clearly been used by the potter whilst stoking the kiln (Fig. 21). The front wall suggests a rectangular kiln, unusual for a pottery producing coarseware. Slight remains of a second kiln, probably circular,



FIGURE 21 Kiln discovered in 1977 during a housing development in Temple Street, Brill. The insert shows a potter's mug which was still in place in a niche above the stokehole where a brick was missing. The kiln probably dates to the early eighteenth century

overlay the infilled interior of the first. It was not possible to separate the products of the first (earlier) kiln from the later one. The products generally are thought to date to the early eighteenth century. They were predominantly bowls, then jars and lesser quantities of plates and cups. Saggars (containers which protect vessels from direct contact with the flames) were extensively used. They are likely to have held glazed cups. Ring-stilts were also used as vessel supports for glazed wares within the kilns (Fig. 22). The wares were predominantly red earthenwares: internal glazing was common. There was a little marbled slip-decoration. An almost complete marbled-slip bowl, almost certainly from Brill, has been found in Aylesbury (Fig. 23). A very small proportion of glazed wares were in a white fabric, unusual for Brill. These included bowls, plates and cups. [HER 02153]

j) Yeoman (1988). A little north of the Prosser's Yard kilns on Temple Street (above), two further kilns were found in 1983 in advance of housing development. Part only of Kiln 1 survived as it had been truncated by the construction of Kiln 2. A stoke pit opened onto the remains of a brick-floored chamber of Kiln 1: apparently semi-circular, it was almost certainly a pottery kiln. The later Kiln 2, built mainly of brick, was rectangular with evidence that it had a floor supported by longitudinal triple arches, a form typical of brick kilns e.g. at Leyhill, Bucks (Farley & Lawson 1990). Kiln 2 certainly produced ridge tiles and probably also ordinary peg-hole roof tiles but a considerable amount of pottery waster material was recorded in direct association with it and so either intermittently, or at a late stage in its life, it seems to have been used for pottery production. The picture is complicated by the presence not only of these two kilns but of other pits and possible stoke holes on the site. The pottery



FIGURE 22 Two ring stilts and a saggar from excavations at the 1977 kiln site, Brill



FIGURE 23 Eighteenth-century marbled slipware dish found in Aylesbury: a product of the Brill potteries



apparently directly associated with Kiln 2 is dated fifteenth to seventeenth century. Products included jugs, pitchers with splashes of glaze, jars (some with bung-holes) and bowls, glazed 'Cistercian-type' cups (Fig. 24), as well as pipkins and chafing dishes. Saggars were present.

After completion of the excavation a nearby contractor's footing trench cut through a substantial dump of ceramic including wasters of late seventeenth to eighteenth-century date. This is briefly mentioned by Yeoman and illustrated (1988, 131; plate 23). The County Museum has two large pieces of waster jug from the deposit: one, the larger jug, has a detached jug neck and handle fused to the base of its interior. Both had black glaze externally on their upper two-thirds and the larger one was also glazed internally. [HER 052930]

k) Murray (2001). In 2001 a substantial amount of pottery including many complete or almost complete vessels was recovered during an evalu-

ation on land on the south side of Windmill Street, at the rear of the Sun Hotel. Although no direct evidence for a kiln was present, it was clear there must have been one in the immediate vicinity. Most of the pottery came from one of the three evaluation trenches.

The pottery recovered is probably of eighteenth-century date but could be either a little earlier or later than this. Most came from the fill of a large pit and from a waste dump. On discovery, many vessels were found upturned and stacked inside one another and a number had 'glazed ring marks on their external sides and bases, caused by vessels stacked or collapsing on top of each other during firing.' The sherds included glazed-over-breaks, blistered glazed surfaces, etc. The assemblage is likely to have been the result of a single failed firing from a nearby kiln. Most of the vessels were in a reddish fabric and glazed internally. Apart from one black-glazed mug, clear lead glaze was utilised. Bowls and dishes were common, many slipped



FIGURE 24 Two Cistercian-type waster cups of late fifteenth to sixteenth-century date from Brill in the County Museum (926 and 927.39). There is no close provenance for the findspot, but saggars which could have contained such cups and wasters from kilns that have been excavated suggest locations where they may have been made

internally with random splashes of bright green (this technique was used also in the later Hubbocks kiln on Tram Hill), and some had vertical lines of slip internally. Jars were also present, a few jugs and chamber pots, a single bung-hole jar, a mug, and a chicken feeder (possibly residual). Some ring-stilts were present. Dumped deposits of blue-grey clay were recorded and a small sub-circular platform of limestone. [HER 1164701]

l) Williams (2010). Following an evaluation in 2009, an excavation was carried out at 7–9 Temple Street, within the former Prossers' Yard (see (i) above). One kiln had previously been recorded and another reported here: the 2009 excavation was south-west of these. At least a dozen pits were encountered, the largest being 2.5m across. No certain use for these was established but a number contained kiln waste dating to the fifteenth and sixteenth centuries. A rectangular configuration of six postholes was interpreted as the location of a drying shed. A large proportion of the vessels recovered were saggars, two of which had cup bases adhering. After excluding 'residual' material a sixteenth-century date was proposed for the bulk of the pottery, which was suggested to be a little later than a similar group examined at Ludgershall (below). The relation between these excavated features and those previously recorded on site could not be established. [HER 09877]

m) Yeates (2012). Recording of the structure of The Red Lion pub on Church Street during alterations also included recording of associated groundworks. A re-dug footing trench at the north-west end of the premises exposed the upper part only of the north wall of a barrel-vaulted structure, largely destroyed and infilled, which lay partly beneath the end wall of the present building and would have extended below the present pavement. The structure might have been part of a kiln similar to that uncovered in Prossers Yard, but its overall dimensions and indications as to whether it might have been either part of a firing chamber or stoking area are unclear. Dating evidence was limited, but it appears to have been in use during the eighteenth century.

#### *Potters*

c.1210–20. Sampson le Potter and Walter le Potter (above).  
1254–5. Peter of Brill (and John Alan, above).

1580. Edwards. Local historian Ian Rodgers records *in litt* to MF, dated 21 June 1983, that he held the deeds referring to his grandmother's house in Temple Street 'occupied in 1580 by Edwards, a potter.'
1628. Edwardes, Robert, potmaker (Hunt *et al* 2001, 125). Probably the same family as above, as in 1640 James Edwards of Brill is recorded in a will as a potmaker (We/ 33/ 204).
1640. James [Brill] potmaker (Hunt *et al* 2001, 125).
- c.1660. Shipperley. Ian Rodger notes (*in litt* to MF, Feb 1983) that a potter by this name lived at what is now 20 South Hills, The Common, 'around 1660'. The deeds were shown to him by Mrs Hanssen.
1682. A rental refers to 'The kilne men', and names: Thomas Hunt sen., Thomas Hunt jun., Austin West, John Wedge and Philip Scoly [*sic*]. Of those named both Wedge and Scoly are later certainly identified as potters rather than brickmakers (D/ AF/12/5).
1682. A deed refers to Philip Scholey, potter, one of the sons of Robert Scholey, potter (D 104/15).
1689. John Wedge has his will proved in 1689 (DAWE 40/98 and 54/204.). Presumably it is his son, also John Wedge, also a potter, who has a will proved in 1713/14 (DAWE 52/241 and 66/154) in which he bequeaths property to '... his daughter Anne, wife of Philip Scholey jun. of Brill aforesaid, potter'. A third John Wedge, also a potter, has his will proved in 1742 (DAWE/77/65). [Note, one potter's daughter marrying into another potting family is not unusual.]
1713. Robert and Phillip Scholey. A deed relates to 'All that messuage or tenement with appurtenances together with a potters killne or kill...' (D 104/15).
- 1713–14. John Wedge (2), see 1689 (above).
1715. John Wood. Deed of settlement, John Wood potter of Brill and Richard Wood, carpenter, deceased (D/HO 21).
1716. 'John Wedge and Philip Scholey junior, potters of Brill, for digging up the highway at Houndsmore in the parish aforesaid [Brill]', appear in Sessions Records (Hardy 1951, 171, 179).

1740. William Freeman of Ludgershall is apprenticed to Arthur Scholey ‘to learn the trade of a potter’ (PR 138/14/14).
1742. John Wedge (3), see 1689 (above).
1742. Scholey family. A bundle of deeds relate to the Scholeys who are always described as potters (D104/15):
1742. Arthur Scholey (his will was proved in 1749 (DAWE 82/187 and 87/187). See above for 1689 will of John Wedge, which includes reference to an earlier Philip Scholey.
1747. John Scholey. lending money.
1748. Mortgage between John Scholey and William Smith, Brickman.
1753. John Scholey and conveyance of a ‘pott kiln’ to Thomas Saunders.
1765. Robert Scholey has his will proved (DAWE/ 48/172).
1766. Philip Scholey (see Fig. 15 for an earthenware pipe probably with his name on it).
1768. Conveyance to Thomas Saunders of a messuage, garden plot and potkiln.
1789. John Scholey involved in a mortgage.
1747. William Wood, potter of Brill (see Hedgerley).
1748. John Harding of East Claydon is apprenticed to William Wood ‘to learn the art of a potter’ (PR 51/14/5).
1764. A John Shipperlee pot with ‘MM 64’ on the front and the potter’s name on the base has been noted above (Fig. 12).
1766. Moses Hubbocks. A marriage licence was issued for Moses Hubbocks, potter, of Great Kimble and Sarah Shipperlee of Brill (D-A/M/ H 1217). Both surnames occur as Brill potting families. Although it is possible that Hubbocks was a Kimble potter (see Kimble) it is perhaps more likely that Kimble was his birthplace.
1768. Thomas Saunders. Conveyance to him of a messuage, garden plot and potkiln (see Scholey above).
1780. John Shipperlee, potter (certainly the same person as 1764, see above), made his will. He purchased his property from Thomas Tapping. Shipperlee survived until c.1816 (DAWE 131/53).
- 1791–1877. The Hubbocks family. The family have a long history in Brill (see 1766). In 1791 Thomas Hubbocks incised his name and the date on a pot (Fig. 13). In the *Posse Comitatus* of 1798 he is the only potter to be recorded in Brill (Beckett, 1985, 72). In the 1841 census, Mary Hubbocks 65; William Hubbocks 35; Henry Hubbocks 30 and a younger Mary Hubbocks age 5 are all listed as potters living in Temple Street. In her 1841 will, Mary Hubbocks, potter (D/A/We 145, no 7) bequeaths to her son Henry ‘...also my stock of wood in the yard and all the ware in and out of the kiln’. She died about 1847. In the 1851 census Henry Hubbocks is the only potter recorded at Brill. He dates a pot in 1861 (Fig. 14) and continues to be listed until 1881, by which date he is 72 years old. His premises are shown on the tithe map of 1853 (CBS tithe 63) which lists him as the owner of a house and garden; brickyard and kiln; kiln and sheds and brick kiln (nos 510–13) in an isolated cluster on the common. He was also the occupier of a house, gardens, yard and buildings on the west side of Temple Street (492, 493). The plan shows a long drying shed here but it was a pottery kiln that was examined here in 1975 (above). He also had land on the opposite side of Temple Street. *Kelly’s* lists him between 1854 and 1877. VCH (2, 1908, 115) notes although he had died about 32 years previously, his kiln was still standing. The kiln recorded in 1975 must represent a move from the common to his Temple Street premises a little further east.
1841. Charles Pratley (50) potter, Anne (40) and four children are recorded in the census, living on the Thame Road (*n.b.* there is a Pratley working at Winchmore Hill in 1853).
1853. John Meads. Apart from the Hubbocks kiln (above), the tithe map records a brick kiln and pottery in the possession of John Meads (plot 412). This is also on the common to the west of Hubbocks’ premises. [HER 4651]
1882. A printed leaflet produced by Thomas Home, ‘Brick and tile manufacturer, Cross Roads, Brill’ refers to the rights of commoners granted in 1626 and 1629. Home wishes to erect a shed containing a clay mill but is opposed by The Duke of Buckingham and others (D-X 801/42).

**Buckland** (and Cholesbury & St Leonards)

Buckland is one of a number of long, thin, Chiltern parishes. It commences near the foot of the scarp to the north-west of Buckland village and the parish church, and extends about seven kilometres further south onto the dip slope near Cholesbury at the settlement called Buckland Common where a number of parish boundaries converge. In 1934 parish boundary changes brought Buckland Common into the newly formed parish of Cholesbury-cum-St Leonards.

The 1812 OS 2" survey shows that the present Buckland Wood west of the common once extended much further to the east than it does today, confining Buckland Common itself to a relatively small area. The former wood is now occupied by Buckland Wood Farm, to the north and east of which lie old clay pits and a brickworks (Pike 1985). All are likely to be of post-clearance date, so the earlier pottery industry was probably confined to a small area of Buckland Common within the then parish of Buckland, although in records potters names also appear against Cholesbury and St Leonards.

*Kilns*

The County Museum has sherds collected by Horace Brackley from the garden of 'The Potteries' (272.74: SP 9244 0716) and two nearby properties (293.74 and 294.74). All three groups contained brown-glazed domestic wares on bricky fabrics of late eighteenth to mid-nineteenth-century date. Of these, one assemblage (294.74) contained eight waster sherds. Two slipware dishes bequeathed by Horace Brackley are thought to have been made at Buckland Common (1993.141. 10 & 11). See below for other pots made here.

*Potters*

1684. John Tomkins. His will provides the earliest reference to the industry. He is recorded at St Leonards (named after the chapel adjacent to the common) (D/A/Wf/52), but see a later reference to a John Tomkins at Buckland Common.
1697. John Tomkins. A bundle of land documents including mortgages that relate to land in 'Aston Clinton' include an agreement of 1697 between Tomkins and William Hill about 'the pot house' (CBS: Box 41, 961-968/38). A number of other documents

in the bundle have been annotated some time after they were written with the title 'the pot house'.

- 1700-01. Thomas Brackley, potter, Buckland was twice convicted of swearing (Hardy & Reckitt, 1936, 282, 293). Thomas Brackley of Buckland was married at Cholesbury in 1701 and in 1705 a son, also Thomas, was baptised here (Brackley & King 1965).
1713. Moses Middleton of Cholesbury, potter, appears in the Cholesbury Court Roll (D/BASM/20/5). He appears again in 1730 in connection with a message and cottage (D/BASM/20/6).
1728. Samuel Roeden of Hawridge, buried at Cholesbury in 1728 was a 'seller of earthenware' (Hay 1971, 140).
1749. Joseph Tomkins, potter at Buckland Common (above). His will is recorded (Kidd 1993, 46).
1759. Thomas Brackley is named on an inscribed pot, now at Chequers. Brackley and King (1965) quote from the *Catalogue of the Principal Works of Art at Chequers* (Anon 1923) as follows:

'Jug, red earthenware, with dark manganese-brown glaze, globular body, short reeded neck, small loop handle. On the shoulder, star-shaped devices, and the inscription "JOHN REVET: ESQR, 1759 THOMAS BRACKLEY POTTER AT BUCKLAND COMMON" incised after the application of glaze but before firing. Buckland near Aylesbury. H.13 3/8" diam 10".'

The catalogue includes a photograph of this jug (*ibid*, plate XLVI) and also another attributed to the Buckland industry as follows:

'Jug, red earthenware, covered with dark manganese-brown glaze, globular, with short neck, small handle with three thumb marks at its base and reeded round mouth and shoulder. On the front "HK 1701" incised under the glaze. Probably made at Buckland Common, near Aylesbury. This jug has always been at Chequers and is of special interest as the work of a small rustic pottery hitherto unrecorded in the literature of ceramics.'

Figure 25 shows that both jugs are nearly identical, confirming the latter's Buckland provenance.

1767. Thomas Brackley is recorded in the Court Book as having made an encroachment 'by erecting part of a furnace or Pott kiln and a little stable' (Hay 1971, 173). Brackley and King (1965, 415) note the existence of a further jug in private possession, inscribed with date 17(?)?) beneath which is the name 'Brackley'. This Thomas must be a son of the Brackley mentioned in 1700–01. Hay (1971, 171), possibly using parish registers states, that: 'In the middle of the eighteenth century we find...there is another potter at Buckland, John Hopkins'.
1798. William Cock, Charles Cooper, John Cooper, John Norris, Thomas Norris and William Osborn are all recorded as potmakers under 'Cholesbury' in the *Posse Comitatus* (Beckett 1985, 177).
1812. OS two-inch to the mile survey, see above, on location of the common.
- 1818 & 1819. William Cook (possibly Cock above) and James Chandler are described as 'pot-carriers' in the Cholesbury parish register (Brackley & King 1965, 415).
1819. Thomas Osborne recorded as a pot maker in the parish registers (Brackley & King 1965, 415).
1821. James Brackley recorded as a pot maker in the parish registers (Brackley & King 1965, 415).
1823. Emanuel Pratley (it seems very likely that this is a probably a misspelling of Brackley or that he intentionally changed the spelling, see 1841 below. In 1834 Job Brackley appears in the Register of Electors having a Freehold House and land at Buckland Common (see below for 'Job')
1841. Emmanuel Pratley (40) pot maker, Buckland and James Pratley (45), pot maker, Buckland (Ce). By 1851 Emmanuel was potting at Winchmore Hill. Others of his family appear later at Seer Green and Hedgerley Dean.
1842. The Enclosure Commission allocated 16 Poles to Job Brackley ('The Potteries') for loss of common rights on Buckland Common, but does not indicate whether he was then actually working as a potter (Hay 1971, 204).

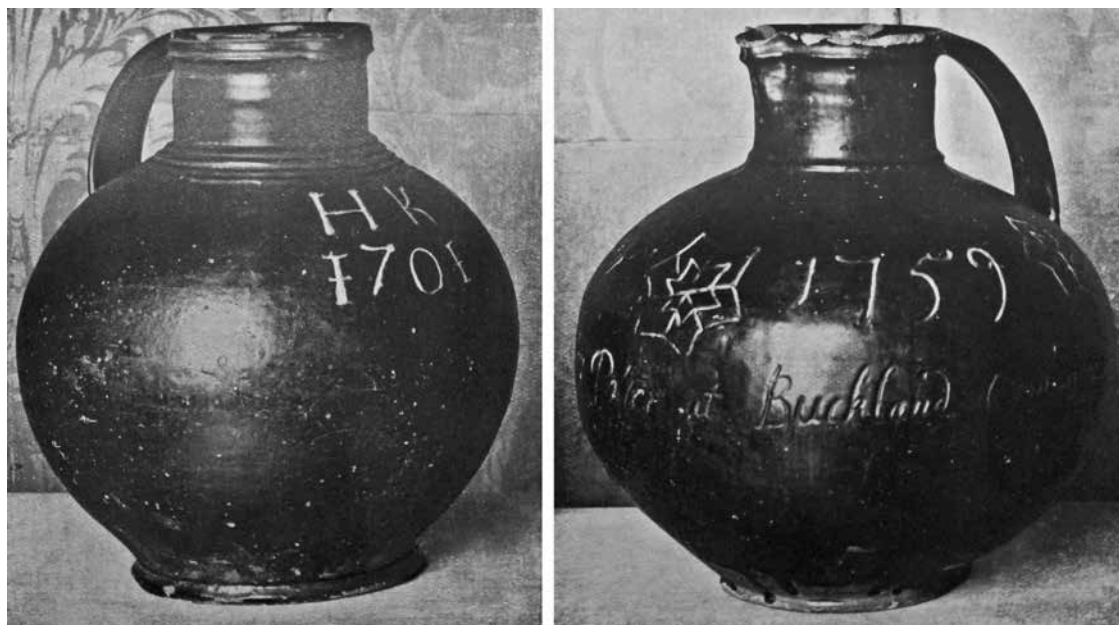

FIGURE 25 Two Buckland-made jugs in the collection at Chequers (reproduced from Anon 1923)

1851. Job Cox (55) hawker of brown ware, born Cholesbury (Ce). No potters are recorded in subsequent censuses.
- 1853–1858. Three children of Job and Eliza Cox were baptised at Cholesbury. Job was described as a potter (Brackley & King 1965, 415). He was probably the last potter in the area.
1862. Sheahan (1862, 109) referring to Buckland Common notes: ‘On a part of the “common” – a lonely spot – are the remains of a pottery, where the common brown wares was formerly made’.

#### *Indicative Names*

1844. The Buckland tithe map of 1844 shows properties on Buckland Common in some detail and marks ‘Pottery Road’ (CBS IR 89 Q), although the schedule records no potters and only one brickmaker, Job Brown (house, brick kiln and yard, plot 329). Brown’s yard is a little north of the road but adjacent to it a group of ponds are shown, former clay pits.

**Cadmore End** see Fingest and Lane End

#### **Calverton**

Calverton was an independent parish until 1927, when it was incorporated in Wolverton (Youngs 1979).

#### *Indicative Names*

Two early names have associations with pottery: *Potsscherdes* 1332 (Bodleian MSS. D.D. Radcliffe Trust 100); *Potcherduc* (c.1352 Bodleian MS 100). A name recorded in 1686, *Pot Yards Piece*, may only indicate horticulture (VCH Bucks, IV, 308).

#### **Chalfont St Giles**

#### *Indicative Names*

The 1841 tithe map of the parish records a field called Potters Croft, at that time under arable (BRO Tithe 81). It now lies beneath a housing estate at Little Chalfont c.SU 993 968.

#### **Chalfont St Peter**

In 1861 Chalfont St Peter, formerly a very large parish, along with four other parishes, lost land to the newly created parish of Gerrards Cross (Webb

1992; Youngs 1979). The parish’s southern end was adjacent to the town of Beaconsfield, a parish which had acquired a church by 1238 (VCH 3,163) but had formerly been part of Burnham.

There were two potteries in Chalfont St Peter parish in the later nineteenth century, the ‘Beaconsfield Pottery’ at Durrants Heath, quite close to the town of Beaconsfield and sometimes mistakenly attributed to that parish, and the ‘Chalfont Pottery’ near Oak End, a short distance east of Marsham Farm and closer to Chalfont St Peter village. The former had a much longer life than the latter, which apparently only came into existence in the latter half of the nineteenth century. There is much surviving information about the former (CBS: EDCSTP2/130, D/BMT/47/R, D/69/1/31) but it has proved difficult to find much about the latter; nor in some instances has it proved possible to determine at which site individual potters were working. At some period both locations produced bricks and tiles as well as pottery. Further local research could no doubt untangle some of the problems the authors encountered.

### ***1. The Beaconsfield Pottery***

#### *Kilns*

The 1811 OS Surveyors map marks a ‘Brick Kiln’ on the east side of the present Potkiln Lane, east of Beaconsfield and west of Stampwell Farm (SU 966 900). In 1862, Sheahan (1862, 827) notes, ‘At Durrants Heath is an earthenware pottery, and a brick and tile manufactory.’ The Chalfont St Peter tithe map of 1840 (CBS Tithe 82) is the first detailed map to locate this works (Fig. 26). A plot of land on the west side of the lane, which the apportionment describes as ‘Cottage, shed, brick kiln and clay pits’, is labelled on the map ‘Pot Kiln’. On the east side of the lane, three other plots that encroach on a trackway are labelled ‘Durrants Heath’ and the apportionment records them simply as ‘House, garden and orchard’: however, the map shows buildings whose elongated form clearly indicates that they are brick or tile drying sheds (‘hacks’). John Bernard was then the owner of both and John Swallow the occupier. A transaction of 1896 which incorporates an earlier printed auction plan of 1858 shows the same areas and buildings naming them ‘Beaconsfield Pottery’: however, the 1851 census places the potter John Swallow at the ‘Chalfont Pottery’. This initially led to some

problems for the writers, but it became clear that in 1851 there was only one pottery in Chalfont St Peter parish. The ‘Beaconsfield Pottery’ was initially referred to as the ‘Chalfont Pottery’ or sometimes the ‘Swallow Pottery’. Only in the late nineteenth century did it become the ‘Beaconsfield Pottery’ to distinguish it from the new arrival (below). It may be that the site commenced as a pottery on the west side of Potkiln Lane, as noted above, but subsequently expanded into brick and tile production on the east side.

The document bundle noted above (D/X/3/3) contains a number of papers relating to the land on which the pottery was built, which lay within the Wilton Park estate, at the time the seat of the lord of the manor. These have not been examined in depth, but in 1808 William Wellings (a ‘gentleman’, not referred to as a potter) appears to have acquired the land from the estate. An attached plan shows that by that date the land on the east side of the lane already had buildings on it whose form, as noted above, clearly indicates the presence of a brick-works. A sale catalogue of 1824 in the same bundle notes under Lot 2 that ‘...NB the large pottery, brick kilns in the parish of Chalfont, advertised for

sale on the 14<sup>th</sup> July is postponed’ (D/X/3/3). Two potters registered births at Beaconsfield parish church at an earlier date, one in 1814 and another in 1815 (see below). They are likely to be Chalfont St Peter (later ‘Beaconsfield Pottery’) potters who utilised Beaconsfield church for baptism in view of its proximity.

At a Court Baron in 1831 John Barnard, later identified as a ‘gentleman of Lambeth’ is noted as a customary tenant of six acres called Darwin’s Heath and of ‘several brick kilns, kiln houses and all other houses which have been erected...’ The 1834 register of voters (PB/R/2) confirms that Barnard held a ‘freehold and copyhold’ kiln. The slightly later tithe map of 1840, noted above, records Barnard as the owner and John Swallow as the occupier. Parish registers (below) indicate that Swallow had been at work here before this date.

In 1847 Swallow is noted in *Kellys* as ‘brick and tile maker and pot kiln’ at Beaconsfield and similarly in *Slater’s Directory of Buckinghamshire* of 1850. The 1853 *Musson and Craven’s Directory* notes John Swallow as an earthenware and brick manufacturer at ‘Durrants Heath’. In 1854 *Kellys* records what is undoubtedly the same

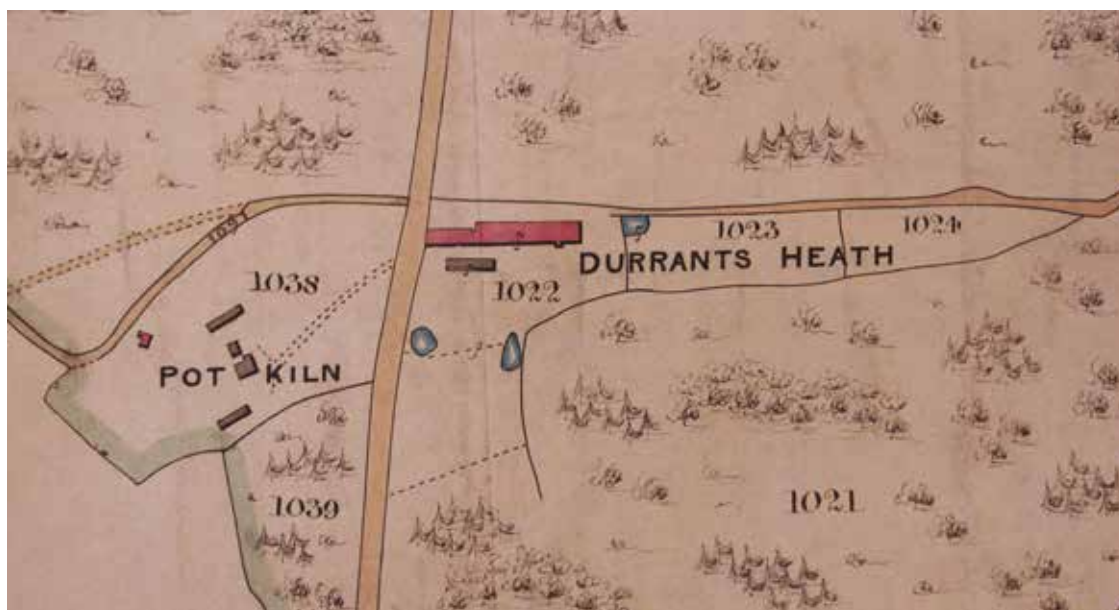

FIGURE 26 Tithe map of 1840 showing the pottery (later the ‘Beaconsfield Pottery’) on Potkiln Lane (reproduced courtesy of CBS)

man as 'John Swanner potter, Pottery, Chalfont St Peter'. By 1858 Swallow had died and Barnard had let to John Thomas, Mathew Swallow, Robert Swallow and James Swallow, all Beaconsfield potters, the premises consisting of a 'cottage or tenement called Pot Kiln House with the Pot Kiln outhouses stables, tenement etc... with the garden ground clay and other pits thereto'. Three of the new occupants were presumably John's children. In 1859 Robert Swallow is referred to as a brick-maker at Darwin's Heath, but in the 1861 census he is described as a 'master potter employing 10 men and 1 boy'. This number probably includes three other Swallows listed in the same census, James (journeyman potter), John T (potter) and William (potter), although two have addresses at Seer Green (close to Beaconsfield) and one at Chalfont St Giles. Robert appears in the 1863 *Dutton and Co's Directory* as 'potter, Pottery' under Chalfont St Peter.

Subsequently Robert Swanner (again probably a mistake), appears as a potter under Chalfont St Peter in the *Kellys* of 1864, 1865, 1869, 1877 (*Cassey's* 1865 *Directory* has a John Swallow as a brick-maker at Pitlands Wood). In 1878 Robert Swallow was made bankrupt (Hunt & Thorpe 2009, 87) and in 1880 he sold his interest in the 'dwelling house mill house kilnhouse warehouses and drying and moulding lofts stables store and other sheds... known by the name of the *Beaconsfield Pottery*' to George Chearsley. However, a year later Robert, who was then 54, appears in the 1881 census as a 'potter employing 6 men and 1 boy', probably including three other Swallows, John, William and Mathew, variously described in the census as 'red potter (earthenware) or just 'potter', so presumably Robert continued as a manager here. In 1881 another licence to dig brickearth at Darwin's Heath was issued (document bundle previously noted). Robert's last appearance was in c.1883 in *Kellys*: about this time the pottery was leased to Martha Saunders. In 1884 the land including 'several brick kilns, kiln houses and all other houses' was in her occupation. Mrs Saunders had a licence to dig 'brick earth, sand and chalk' and to 'manufacture the same into bricks, tiles or other like ware.' A surrender of land referring to Darwins Heath notes land once 'in the occupation of William Wellings... and for many years of Robert Swallow and now of Martha Saunders... and also the several Brick Kiln Houses.' (D/69/1/31). This is confirmed in the

Chalfont St Peter Manor Court rolls (Neal c.2011).

Martha Saunders was born at Seer Green (Ce) in 1844. She married Albert Saunders, a brickmaker, in 1869. He died in 1882. In the 1887 *Kellys* Mrs Saunders appears as a potter (Chalfont St Peter) and in 1895 her son is also noted. In the 1891 census she was a widow and 'manufacturer of pottery ware'. However, in the same census it may be noted that two of the younger Swallows, William and Henry, are still potters here and Arthur Joseph Swallow was a potter's labourer. Perhaps these members of Robert's family continued working for Mrs Saunders at the pottery under her direction. This conclusion is strengthened by the fact that the boys' mother, Rose Hannah Swallow, a widow, was living on her own means at Swallows Pottery. In 1896 another map in the document bundle noted previously shows that the 'Beaconsfield Potteries' now extended over both sides of Pot Kiln Lane and were occupied by Martha Saunders and Son. On the 2<sup>nd</sup> edition OS 6" map of 1900, a 'Brick and Tile Works' and clay pits are shown here.

In about 1908, VCH (1908, 115) notes of the Beaconsfield Pottery (using family information) that 'It has never assumed very large proportions, and Mrs M Saunders & Son, the lessees of the pottery, now chiefly produce flower-pots, stands, chimney-pots and pipes and similar articles. It has, however, continued working to the present day in spite of the keen competition in the industry.' Between 1911 and 1928 she and her son appear in *Kellys* as 'pottery, bricks, tiles and sanitary ware manufacturer and builders' merchant pottery', the last entry being in 1939. Their location is given as 'potters, Pottery' a phrase which frequently serves to differentiate them from the Chalfont St Peter pottery (below). Bennell (1964) recorded that at that time the business still manufactured 'earthenware pipes and chimney pots.'

In 1978 a visit paid to the Beaconsfield site noted that 'Some of the original sheds still survive, and outside the last shed furthest from the road [presumably the eastern complex] are the remains of a circular kiln of red brick, embedded in the drive.' The whole was then still owned by the Saunders family (HER 2565).

#### *Potters*

It is fairly clear that it was the (numerous) Swallow family that eventually became established as principals at the Beaconsfield pottery.



In the 1851 census, John Swallow was described as ‘potter master eleven men and one boy, in 1861 the numbers have diminished a little and by 1871 Robert Swallow was employing only seven men and three boys. In the 1881 census the pottery is referred to as ‘The Swallow Pottery’ although shortly after (see above) it was to be taken over by Martha Saunders. As the Chalfont Pottery was not established until later in the nineteenth century, the potters listed below up to the 1850’s are likely to have worked here.

- 1814. A son born to William Skinner of Chalfont, potter (Beacs. Hist. Soc. 1973, 119).
- 1815. A son born to Anne and Frederic Baker, potter (Beacs. Hist. Soc. 1973, 120).
- 1826. A daughter born to Rebecca and James Goddard, potter (Beacs. Hist. Soc. 1973, 136).
- 1826/7. A Son Robert born to Mary and John Swallow, potter (Beacs. Hist. Soc. 1973, 137).
- 1832. A son born to Elizabeth and Charles Carter, potter (Beacs. Hist. Soc. 1973, 145).
- 1840. The tithe map (plot 1038, see above) has John Swallow in occupation.
- 1841. Census, see Appendix
- 1847. John Swallow, ‘brick and tile maker and pot kiln’ [under Beaconsfield]. *Kellys*.
- 1851. Census, see Appendix.
- 1861. Census see Appendix.
- 1871. Census see Appendix.
- 1881. Census see Appendix.
- 1891. Census see Appendix.

## 2. *The Chalfont Pottery*

In contrast to the ‘Beaconsfield’ pottery it has proved difficult to discover much about the ‘Chalfont Pottery’ which is situated much closer to Chalfont St Peter village than the ‘Beaconsfield’ pottery. It is thought that it originated as a brick and tile works but subsequently diversified into production of domestic wares.

### *Kilns*

A ‘Kiln’ is shown two kilometres south of Chalfont St Peter (TQ 009 886 on the first edition OS map of 1822: base map date, some revision and electrotyped 1870). The kiln lay on the eastern edge of Gerrards Cross Common, just north of the present Oakend Way, west of the old London Road, and

south-east of Scrubbs Wood. The general area is marked on the early OS map as ‘Mason’s End’. The Chalfont tithe map of 1840 (CBS Tithe 82) marks the same place (plot 753) as ‘Chalfont Kiln and part of kiln yard’. It shows a water-filled pit and several long buildings typical of brick or tile drying sheds. The owner was then John James Dolan and the occupier William Henry Piner, who also occupied about twenty closes in the vicinity. A little later the 1847 *Kellys* records Henry Piner as farmer and brickmaker under ‘Chalfont St Peter, Gerrards Cross’, and this entry must relate to the same kiln. The Piner family had been brickmakers in the parish for some considerable time: a Richard Piner is recorded as a brickmaker in Chalfont St Peter in 1736 (Kidd 1993, 41).

Although not providing a clear location, the 1861 census continues to record Piners in the general area of the kiln noted above, as can be seen from the enumerator’s area which covered ‘... part of and including side and top of Gold Hill, Austin Wood, Backer Lane, the Grange part of Chalfont Park, *Mason End Lane, Piners Farm and Brick Kiln Gerrards Cross*, part of Bulstrode Park, Maltmans Green Bull Lane and Packhorse.’ Although ‘Piners Farm’ (called Meduslem Farm, see below) has not been located on any map, Mason End Lane must lie at Masons End which (as noted above) is shown in the same locality on the 1822 OS map (but with some later detail revised, see above). The reference to Gerrards Cross is due to the transfer of this part of Chalfont St Peter into Gerrards Cross parish in the same year that the census was taken (see above).

The 1861 census shows that Henry Piner was a major employer of brickmakers and lists Henry Piner (60) Meduslem Farm, Mason Lane, farmer and brickmaker, employing 16 men; Ann Piner (56) Meduslem Farm, Mason Lane, farmer’s wife; William Piner (51), Mason End Lane, brickmaker; Eliza Piner (49); Thomas Piner (21) brickmaker; five Piner children age 13 and under and finally Richard Roe (40) also Mason Lane, brick burner. *Kellys* directory of 1869 lists Henry Piner as a brickmaker in Gerrards Cross but there is still no reference to a pottery at this stage (but see below for possible evidence of its existence). The first clear indication of a working pottery here is on the first edition 25” OS map of 1876 (sheet LXVIII.15) where the site of the former Piner brickworks is now marked as ‘Chalfont Pottery’ (Fig. 27). The only other evidence that the writers

have found which gives a clue as to when this transition in the character of the Piner site took place is provided by two pots in the County Museum. Both were donated by Mrs C. Dance of Station Road, Gerrards Cross in 1965. Their accession entry is as follows:

114.65. Bottle, earthenware, dark brown-black glaze, with heavy handle; dated on small lug in front 1858. Ht. 15.75 ins. D. 14.5 ins. This bottle was made at the Chalfont St Peter pottery which was where The Woodlands, Gerrards Cross now is, and was presented to Mrs Dance's Grandfather, Mr Mark Dance, when he was manager of the pottery.' (Fig. 28).

115.65. Mug, brown-glazed earthenware; decorated in relief with hunting scene with dogs, horses and a man. Ht. 4.75 ins. D. of top 3.8 ins. Made at the Chalfont St. Peter Pottery where the Woodlands, Gerrards Cross now is.' (Fig. 29).

It is interesting that the design on the latter seems to imitate rather unsatisfactorily earlier stoneware pub tankards of the Victorian period!

It will be seen that the 1858 date on the bottle, presuming that it is the date of manufacture, is at a time when the Piners were still apparently working as brickmakers in the area (see above). It is possible that both pottery and brickworks occupied the same site, or that the Piners could have already moved on to another nearby site. It may be noted that in *Musson and Craven's Commercial Directory* for 1853, a William Piner appears as a brick manufacturer at Hedgerley Dean, so the family did have wider interests and there were other pits within the newly created Gerrards Cross parish. The pot date apart, by 1861 one potter, James Halsey, was certainly working at the Chalfont site (below).

A letter dated October 1891 contained in manor court files has a printed head 'Chalfont Kiln and Pottery Co. Gerrards' (EDCSTP2 – extra deeds). At about the same time a record of the pottery appears in an unexpected context, *A List of Mines worked*

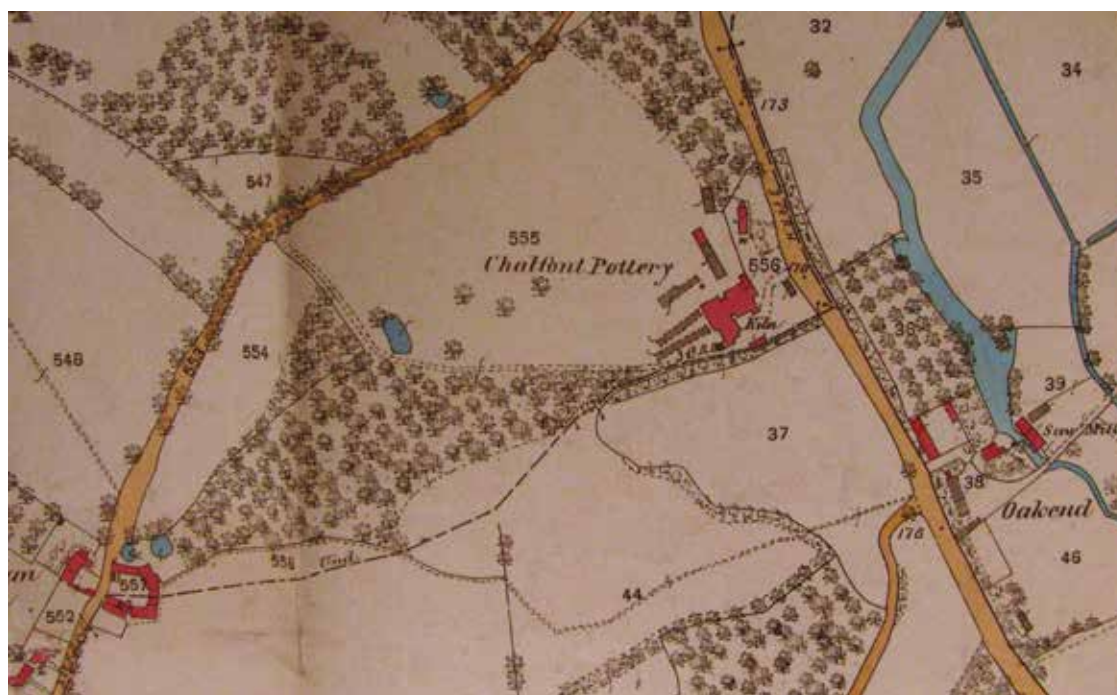

FIGURE 27 Ordnance Survey 25" map of 1876 showing the 'Chalfont Pottery' near Oakend, Chalfont St Peter. Now built over



FIGURE 28 Large bottle said to have been made at the Chalfont Pottery. The inset shows the date 1858 on a lug



FIGURE 29 Tankard said to have been made at the Chalfont Pottery

in the year 1893 under the *Coal Mines Regulation Acts 1872 etc.*, for the year 1893, produced by HM Inspector of Mines. HMSO 1891 [the date must be a misprint]. The entry reads:

Owner. Chalfont Kiln and Pottery Co. (Saunders. F & E.), Gerrards Cross, Slough. Situated: Gerrards Cross. Name of Mine: Chalfont Kiln. Mineral Worked: Chalk and Fireclay. Barmaster: James Bates, Manager. (see below for James Bates)

The same entry is repeated in 1894 and 1895 but no barmaster is recorded. It will be noted that the owner's name is Saunders, the same surname as the family then running the Beaconsfield Pottery. In earlier days, in Derbyshire a barmaster was the holder of mineral rights, or one who granted title to them, so the title accounts for the interest of the Inspector of Mines who is unlikely to have had reason to record pottery production here even if it was still taking place in the 1890s. In 1922, no doubt recording earlier observations, the *Memoirs of the Geological Survey; Explanation of Sheet 255, The Geology around Beaconsfield*, authors Sherlock and Pringle, p. 25 record a 'section at the Chalfont Pottery, 150 yards north-west of Oakend', showing 'mottled clay 9ft, on sand of various colours 21ft; on 2ft of greensand.'

The date when the Chalfont pottery ceased to operate is not known, but on balance it seems likely that it was a fairly short-lived enterprise.

#### *Potters*

As noted above, the Chalfont pottery seems to have been established at the Piners' brickyard. A manager of the pottery (Mr Dance) has been noted above. He appears in the 1861 and 1871 censuses (see below) as Mark 'Dancer', and in a more humble capacity.

#### 1861 Census:

James Halsey (1) (49) potter 'kiln and pottery', Masons Lane, b. Ilford, Essex.

Halsey could have transferred from the 'Beaconsfield' Pottery [NB a younger James Halsey was based at Hedgerley Dean].

James Gibbs (23) potters labourer, b. Chalfont St Giles. As he later lived here also, the Chalfont St Peter pottery would have been his nearest pottery.

Mark Dancer (35) tile maker, Masons Lane, b. Hedgerley. In 1851 he was an agricultural labourer in Hedgerley.

#### 1871 Census:

James Halsey, potter, Chalfont House, Lower Lodge. The lodge referred to is less than 200m north of the site marked as 'Chalfont Pottery'.

Mark Dancer (46) oven tile maker earth, b. Hedgerley. This is the first reference in the county to an oven tile maker. It can scarcely be a coincidence that pots given to the County Museum in 1965 was presented by a Mrs Dance [*sic*] who described herself as granddaughter of the former manager of the pottery. The same census lists a number of other Dancers who were brickfield labourers. Presumably after 1871 Mark Dancer was promoted to manager, but he does not appear in the 1881 census and it is not until 1901 that another manager is evident.

#### 1881 Census:

George Newman (22) potter, Chalfont Lodge, b. Iver.

James Newman (20) potter, ditto (brother), b. Iver.

#### 1891 Census:

James Bates (48) oven tile maker, brick maker, Chalfont Kiln. Bates later became 'Barmaster/manager' (see above). He was born in Amersham, worked in Berkshire, then Rickmansworth area as a brickmaker before moving to the Chalfont Kiln.

James Bates (22) oven tile and pot maker (son) Chalfont Kiln.

Albert Bates (15) tile maker's assistant, Chalfont Kiln.

#### 1901 Census:

James Bates (58) manager, Brickmaker and Tile Works, Chalfont St Potteries, Gerrards Cross.

This seems to be his last post before retirement.

James Bates (32) oven tile maker.

#### **Chartridge** (see Chesham)

#### **Chesham** (and **Chesham Bois**)

Latimer and Chartridge were created as civil parishes from Chesham in 1899. Latimer became an ecclesiastical parish in 1868 (Youngs 1979).

#### *Kilns*

Chesham has two confirmed areas of pottery production; (a) on the margins of the town (two

distinct locations) and (b) a kilometre or so east of the town in the area of Cowcroft Wood, Botley just west of Ley Hill (Layhill) Common (shown on the OS Surveyors 2<sup>nd</sup> map) where there was much common land and a number of sites have been identified. Most of the Common sites now lie within the later parish of Latimer.

Chesham has a long history of brick and tile production. For instance a William the Tyler appears in manor court records in 1341 as he had trespassed with his cow in the Lord's meadow (we are grateful to Garry Marshall for this reference). An inquest of 1378 held at Halton (Boatwright 1994, no. 148) records the death of John from Wendover who fell in front of a cart loaded with 650 tiles that had been collected from Botley. In 1409–10 construction of a new hall at Ivinghoe occasioned purchase of 6000 tiles and 200 ridge tiles etc. from 'Chesham' which is likely also to have been Botley (Page 1999, 153). Manufacture of brick and tile still continues in the area at Bellingdon south of Cowcroft Wood. The production of pottery in the Botley/Ley Hill area has only been recognised in recent years.

In addition to the above, at Lye Green about a kilometre north-west of Botley there is a third possible location area (c), and finally, a 'potter' field name which may or may not be significant.

(a) Chesham town 1. A small excavation by the Chess Valley Archaeological Society took place in c.1972 at Emmanuel Church, Chesham, after sherds were noted here by W.Filby. The pottery, which included wasters, was subsequently published (Cauvain 1979). In 1989 at a time of development at the church, a small excavation and watching brief located a circular brick-built kiln and part of another. Products included jugs, bowls/dishes, costrels and tygs. The material was dated to the early seventeenth-century (Cauvain 1992).

(a) Chesham town 2. Fifty sherds of probable seventeenth-century date including a large proportion that were over-fired, were found on an allotment on Taylor's Farm, Nalders Road (SP 907 022) and reported by Wells (2002). The location is about 0.4km east of the kilns noted above.

(b) Leyhill. In 1966, seventeenth to eighteenth-century sherds were found by Richard

Griffiths on Leyhill Common, and in 1988 fifteenth to sixteenth-century sherds were discovered by G.C. Lamb (HER 1757). Both groups contained wasters. Chaffey *et al* (1988) report the find of several kilograms of thirteenth-century pottery from a house extension on Botley Road. Although no wasters were noted here, many sherds were of very similar form and it is likely that they are products of a local kiln.

Over the years waster pottery has been noted at several other locations in Ley Hill, e.g. Chaffey and Wells (1989), and Wells (2002) who reported a front-garden find of fifteenth to sixteenth-century wasters.

In 1987 a well-preserved single-flue pottery kiln built of brick and tile, which had been constructed within a disused rectangular tile kiln (Fig. 30), was discovered in a garden at Joiners Close, Ley Hill, and reported by Marion Wells (Farley & Lawson 1990). Archaeomagnetic dates on the kiln suggest its use in the late fifteenth century. A considerable amount of pottery was recovered. Jugs and cooking pots accounted for nearly 70% of the vessels. Other vessel forms included pipkins and cauldrons, bowls/dishes, dripping dishes/skillets, bung-hole cisterns, costrels and a whistle. The products rarely showed signs of glaze or of decoration, but a few saggars were present and these could have been used for firing small glazed cups or jugs.

Sherd samples were thin-sectioned and chemically analysed and some were re-fired. The basic fabric had a groundmass of silt-sized quartz grains with flecks of mica. In addition larger quartz grains, some clay pellets, other argillaceous material, quartzite, iron oxide, flint and a little organic material were present. It was noted that the fabric was broadly similar to that from other Chiltern kilns.

1750. A deed notes 'of all that wood called Cowcroft Wood containing by estimation fifty seven acres and of that spring called potters spring and of the two pightles containing by estimation five acres and of all those potters kilns chalk fullers earth and brickworks in the said premises' (CBS D-CH/A/596 and 175). The OS 2<sup>nd</sup> Surveyors map of c.1813 shows a brick kiln at Botley (Cowcroft).



FIGURE 30 The curved wall of a late fifteenth-century pottery kiln can be seen (left), built inside an earlier disused brick/tile kiln at Ley Hill, Botley, Chesham

(c) The Chesham tithe map of 1843 (CBS Tithe 90 and 90A) marks a 'Potters Field' south-east of Lye Green at SP 981 032. An initial field check recovered thirteen medieval sherds. A subsequent fieldwalk produced over three hundred sherds of late twelfth to thirteenth-century date but no conclusive evidence as to whether this was a production site, a settlement, or possibly both (HER 6262).

#### *Potters*

See Appendix. Between 1594 and 1624 the pottery family of Overstreete is recorded in wills and parish registers in the Leyhill/Botley area; a further seven potters' surnames are also recorded between 1624 and 1728. Of these one is located at 'Botley' another just at 'Chesham'

#### *Indicative Names*

(a) See above for 'Potters Field'.

(b) Keith Bailey (*in litt.*) reports two 'Crock Hill' names in a 1629 Wedon Hill rental (info via HER) not far from Halfway House Farm c.SP 943 013 and SP 942 008.

(c) The Chesham tithe map and award 1843 (CBS tithe 90/90A) shows a small group of fields (676, 677) named 'Potters Meadow' adjacent to a building at SP 923 018, a little south of Little Hundridge Farm and adjacent to Blind Lane and Little Hundridge Lane, the boundary with Little Missenden parish. One of the fields contains a pond (possibly formerly a pit?). The current occupant of the house, which is an early nineteenth-century structure, is unaware of any discoveries of ceramic here and a brief flower border check showed nothing unusual.

Recent foundation work revealed dense clay-with-flints. The name may refer to an individual rather than a trade. This location is about two kilometres from the location noted in (b) above.

**Cholesbury** (see Buckland)

**Coleshill** (see Amersham)

**Denham**

### *Kilns*

Two kiln areas were recorded near Rush Green, Denham during construction of the M25 motorway in 1982–3 (Farley & Leach 1988).

The southern site lay on the floor of the valley close to the river Alderbourne. It received reasonably full investigation, albeit under difficult circumstances. Part at least of the site is likely to be preserved since it lay within an open area at the M25 – M40 junction. The northern site, c.700m to the NNW, was observed in construction trenches on the margins of a cleared area of Broadspring Wood on the north side of the Alderbourne valley. Circumstances permitted only a cursory examination here. It is not known if any of it survives in the adjacent woodland.

#### **(1) The southern site**

Parts of three kilns, a fragment of a fourth, and a clay pit dug into alluvial clay, were examined Figs 31 and 32). The kilns were all built of clay. The three best-preserved had opposing flues and a central semi-circular or oval pedestal (Musty 1974: type 2c).

The interiors of each had been modified by a number of rebuilds of the pedestal and by re-lining (Fig. 33). If continued above ground level the latter process would have had the effect of reducing internal capacity over time. Kiln 1 had been replaced by Kiln 2. Kiln 1 had an almost complete jug in one flue (Fig. 34) and kiln bars were present here. Kiln 3 and its fragmentary predecessor Kiln 4, lay 8m distant north. Kiln 3 produced an archaeological date of 1240± at a 68% confidence level.

About one metric ton of ceramic in total was retrieved from both northern and southern sites. Most came from the southern site although only about 5% of the gravel island on which the southern kilns were sited was examined (Fig. 35). See below for products.



FIGURE 31 Two oval kilns excavated near Rush Green, Denham. It can be seen that construction of the further kiln (Kiln 2) had cut the stokehole of the nearer one showing that it was no longer in use

#### **(2) The northern site**

Apart from areas of charcoal-flecked burnt clay, a pit containing plentiful pottery, a piece of kiln bar and burnt clay fragments, the limited examination of this area produced no structural evidence but plentiful sherds. It is notable that kiln bars were found at both northern and southern sites.

It seems that the southern potters utilised alluvial clays and probably the northern potters also, although other options were available to them. Most of the sherds recovered were very small and direct evidence of ‘wasters’ was rare. Some vessels were certainly hand-built and some were wheel-thrown but with most sherds it proved impossible to separate the two techniques on the degraded surfaces which left quartz grits standing proud. The majority were of reduced grey colour. Only 1.2% had any trace of slip or glaze (green to dark green) which was exclusively on jugs (and glazing on these was not common). Other decoration consisted of combing (or wiping); some sherds had applied thumbed strips. Occasionally jar rims were

DENHAM KILNS:  
SOUTHERN

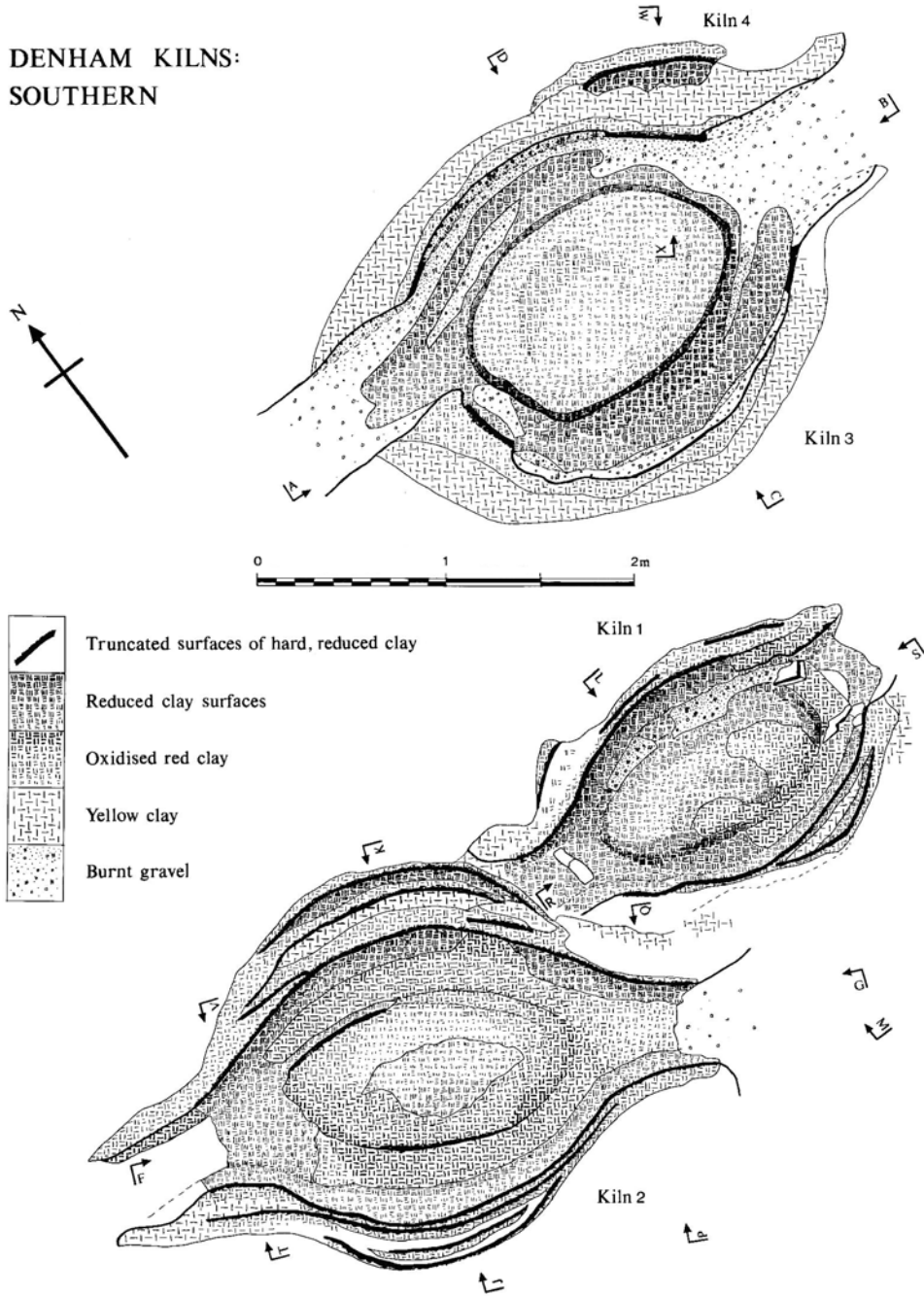

FIGURE 32 Plan of three kilns at Rush Green, Denham





FIGURE 33 Section through the wall and central pedestal of a Rush Green kiln, showing several layers of re-lining of both



FIGURE 34 Jug from the blocked flue of Rush Green Kiln 1



FIGURE 35 General view of the Rush Green kiln site showing the surrounding dark, charcoal-rich soil on the floor of the Alderbourne valley. The bags are filled with sherds collected from metre squares. On the other side of the fence is the striped surface of the M25/M40 junction under construction

finger-tip decorated or stabbed. Jugs had pulled handles of rod or strap form, sometimes thumbed or stabbed. Very approximate percentages suggest that in order of volume the products were cooking pots/jars; jugs; bowls/dishes or skillets; curfews and pedestal lamps. The mid-thirteenth century date suggested by archaeometry is acceptable for the bulk of the products, though one distinct group of handmade cooking pots (found also on a domestic site nearby at Fulmer – Farley 1982a) could be twelfth century or even earlier.

Subsequent to the initial excavation report this group of kilns was included in a study of the greyware pottery industry of the London region, a large group of which the authors classify as South Hertfordshire-type greywares (SHER) (Blackmore & Pearce 2010). The authors note similarities between Denham products and those of Chandlers Cross, Pinner, Camley Gardens (Maidenhead), and in particular Uxbridge. Analysis by spectrometry of elements in the clay shows a source for Denham

very similar to that used in the Uxbridge kilns (*ibid*, 132, 201, fig 146). The study includes illustrated thin-sections of the Denham ceramic. Although greywares were extensively used in London between the mid-twelfth and mid-thirteenth centuries, no specific products of the Denham kilns have been identified there.

### Eton

#### *Potters*

1833. No potters are recorded here, but the presence of a dealer at Eton is worth noting. A case of larceny against Benjamin Pratt of Chepping Wycombe had as a witness Henry Dewgard [of Eton], dealer in earthenware. (CBS: Justices Case Books QS/JC/15. Easter Session 1833).

**Farnham Royal** (including the hamlets of **Hedgerley Dean** and **Seer Green**). See also Hedgerley.

The long thin Chiltern parish of Farnham Royal originally included towards its northern end the hamlets of Seer Green and Hedgerley Dean (Bryant 1825). Seer Green was noted by Sheahan (1862, 848) as ‘formerly an isolated portion of the parish of Farnham Royal. The *Village* which is small and sequestered, stands 2 miles NE of Beaconsfield, and 5 miles from the parish church [of Farnham Royal].’ It was originally also a separate manor (HER 5705). By 1900 Seer Green had become a civil parish (OS 6 inch revision) and its core has been substantially built over. The hamlet centre was only 1.5km from the ‘Beaconsfield Pottery’ in Potkiln Lane. Hedgerley Dean was the general name for an area of dispersed farmsteads immediately west of Hedgerley village (Bryant 1825). In

1894 it became briefly a parish in its own right before merging with Hedgerley and Farnham Royal in 1934 (information from Michael Rice).

The parish boundary separating Farnham Royal on the west from Hedgerley parish on the east, ran north-south along the main street of Hedgerley village continuing on southwards up Hedgerley Hill to the One Pin cross roads. North-east of the main village is the hamlet of Hedgerley Green. Taking into account Hedgerley Dean (Farnham Royal parish) and these two ‘Hedgerleys’, there is scope for confusion in locating potters and potteries. See Hedgerley for other kiln areas.

### Kilns

#### 1. Hedgerley Dean

The 1897 revised OS six-inch map shows a *Potters Arms* (Fig. 36, arrowed) at the junction of Kiln

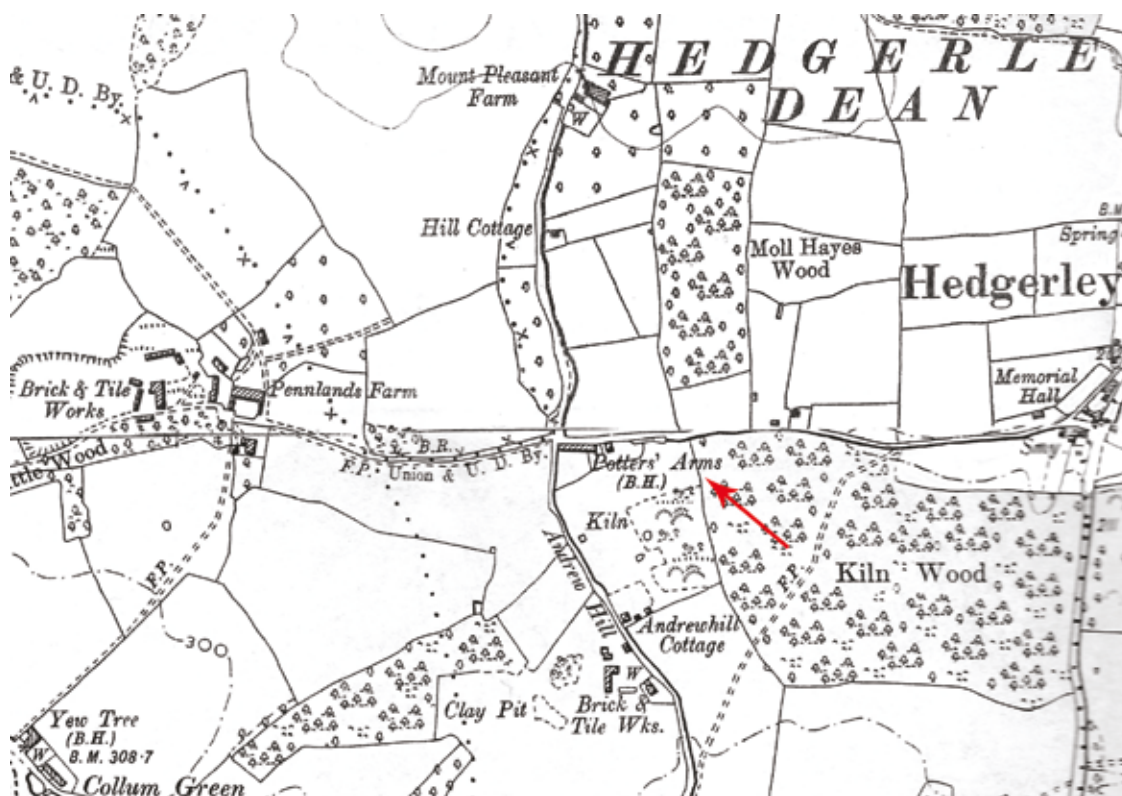

FIGURE 36 Ordnance Survey 6" map of 1897 showing the Potters' Arms and adjacent kiln (the upper part of the map is a 1923 revision)

Lane (leading west from Hedgerley village towards Pennlands Farm, a substantial brickworks), and Andrew Hill Lane. Beside the Potters' Arms is a long building which looks like a drying shed and a short distance south a 'Kiln' is shown. On earlier maps this was marked as a 'Brick and Tile Works'. Rice (1980, 103) notes that the area was called Casualty: 'There was a kiln on the hillside behind the pub from which John Hazell bought earthenware basins and bread bins to re-sell. The men from the kiln came down to the pub at midday and after work for beer'.

A field visit to the site in 1980/1981 produced 'many earthenware flower pot sherds' (HER 4746). This would be a typical product of a pottery kiln operating in the later nineteenth century (possibly in conjunction with a brick and tile works).

It may be noted that there were two other brick and tile works locally, one at Pennlands Farm 200m west along Kiln Lane and noted above (HER 2822; Rice 2006, 92–6), and a second 100m south of the presumed pottery kiln on Andrew Hill (HER 4747). The latter incidentally may be a pit visited by the geologist Prestwich in 1842 (Prestwich 1850).

## 2. *Seer Green*

A leaflet 'Seer Green Stories', compiled to accompany the exhibition 'Seer Green – then and now' in the Jubilee Hall in July 1977, includes a poem about Seer Green said to have been written 'over 100 years ago' (copy with CBS).

'And, if you walk a little way  
You'll see the potter with his clay –  
Flower pots he makes with skilful hands,  
And oftentimes, some larger pans.'

This poem provides the only indication that there might have been a pottery here. No kiln site has been identified. Although some potters are recorded living in the Seer Green census area and they could have been working at an unidentified pottery here, it seems more likely that they worked at the Andrews Hill pottery (see above).

### *Potters*

#### 1. *Hedgerley Dean*

1747. John Wood of Hedgerley Dean, potter, settles a lease between himself and his

brothers Bernard and William of a '... tenement and garden plot in Brill' to 'William Wood of Brill, potter' (D/-HO/34–35), see also Brill.

1861 Census (Hedgerley Dean):

George Collins (33) – pottery (steward) and kiln, Andrew Hill House, b. Chalfont St Peter.

James Helsey, potter, 23, Cottage

1871 Census (Casualty [see above], Andrew Hill House):

George Collins (43) Kiln bailiff, b. Chalfont St Peter.

The following lodged with him:

Amos Hasley (30) kiln labourer, b. Burnham.

Henry Gibbs (28) kiln labourer, b. Penn.

Jesse Bates (22) kiln labourer, b. Amersham.

Charles Pratley (38) potter, b. Buckland. [The Pratley family initially moved from Buckland to Winchmore Hill. In 1861 Charles lived in Seer Green.]

James Pratley (son) (17) potter, b. Great Marlow [it seems unlikely that his parents lived there]. By 1881 James was still potting but lived at Hook in Surrey.

Thomas Loveday (33) kiln labourer, Casualty, b. Beaconsfield.

John Harvey (36) kiln labourer, Casualty, b. Penn.

Richard Bristow (20) lodger with Harvey, kiln labourer, b. Suffolk.

1881 Census:

No potters are specifically recorded at Hedgerley Dean but the kilns were still functioning and there were potters and brickmakers living at Seer Green. Lacking firm evidence for a pottery at Seer Green and given the continuity of name evidence, it can be presumed that these 'Seer Green' census entries are of workers at the Andrews Hill pottery/brickworks.

1891 Census place was 'Pot Kilns'; a gamekeeper John May lived here.

#### 2. *Seer Green*

Potters recorded living here probably worked at Andrews Hill.

1851 Census, no potters.

1861 Census:

Charles Pratley (28) potter Seer Green [NB his father was at Winchmore Hill in 1851, previously Buckland. In 1871 he was at Andrews Hill].

John T Swallow (36) potter, Seer Green, b. Loughton, Essex.

James Swallow (26) journeyman potter, Seer Green, b. Beaconsfield.

1871 Census:

William Slade (40), potter, cottage, Seer Green b. Coleshill.

1881 Census:

Thomas Loveday (44) brickmaker, no address but parish Seer Green.

George Loveday (19) son, kiln labourer.

1891 Census:

George Worley 34, Seer Green, born Seer Green. Labourer in Potteries.

Thomas Swallow (prev. John T.) 66, potter, Seer Green.

Robert Swallow (64) pot maker, Seer Green [other Swallows were at the Beaconsfield Pottery so this might just be their place of residence].

#### *Indicative Name*

1636. Potters Croft (CBS: D-X558/3).

#### **Fawley**

##### *Indicative Names*

Fawley has a Crockmore Farm and adjacent Crockmore House at SU 750 858, 1km east of Middle Assendon (Oxfordshire). The farm, a seventeenth-century building (VCH 3, 37) appears (unnamed) on Jefferys map of 1770 and later on the Fawley tithe map of 1840 (CBS Tithe 165). The field names around the farm (which occupied 100 acres and was then part of the Fawley estate) give no indication of either a 'moor' or pottery production area here. However, an extent of Fawley estate of 1790 (D/X 1238) does list (no. 29) a small area of land as 'part of the Moor' but the accompanying plan is lacking.

About 4.5km to the NNW over the border into Oxfordshire at Nettlebed/Crocker End there was a substantial brick and tile making industry from the mid-fourteenth century (Stebbing *et al* 1980), and

Mellor (1994, 33) notes a 'potter' surname here in 1442 and the death of another potter in 1560. Both potting and brickmaking continued at Nettlebed until the twentieth century. However, the distance between Crocker End and the Buckinghamshire Crockmore does seem a little far for them to have been directly connected, so it seems possible that Crockmore may have had its own industry at some period, though neither the precise location of 'Crockmore' or of a pottery has been established.

#### **Fingest and Lane End (including Cadmore End)**

Fingest and Lane End is the modern civil parish; Lane End, Wheeler End, Cadmer (*sic*) End, and Bolter End are a cluster of hamlets around the neighbouring commons of Wheeler End and Cadmore End (Jefferys map 1770 and Bryant's 1825). The hamlets are within Buckinghamshire but close to the county boundary with Oxfordshire. Fingest has changed its boundaries over time, incorporating parts of Lewknor (now Oxfordshire) and Stokenchurch, and probably in 1852 also part of Great Marlow (Youngs 1979). Sheahan (1862, 899) reflects the complexity of this borderland area, noting that 'The ecclesiastical district of Lane End is partly in the parishes of Great Marlow, Fingest, Hambleton and West Wycombe.'

#### *Kilns*

(a) The local antiquarian Mr S.J. Smith was responsible for most of the discoveries in the Cadmore/Lane End area. It was probably following a report from Mr Smith that in November 1964 Christopher Gowing of the County Museum recorded a 'roughly oval' structure, possibly built of tiles, which 'produced a quantity of pottery, about 500 sherds in all, in addition to some 40 glazed roof-tile fragments' that been found in 1964 during 'construction of new by-pass' for High Wycombe 'about 300 yards to N of NE corner of Marlins sandpit'. The tile layer was beneath a 'burnt red clay area' which in turn was below a 'heavy charcoal layer' [HER 0887 including a sketch; SU 793 926]. The whole was 'much destroyed by heavy earthmoving machinery'. The so-called by-pass was for a short time a new route for the A40 but was soon to become part of the present M40. A photograph of the M40 may show the location of this kiln, placing it on the north side of the motorway (Boarder 1974).

The pottery from the site was dated to the thirteenth and fourteenth centuries. In a fine sandy fabric it included glazed 'baggy jugs with handles decorated with slash marks'. Some (presumably jugs), were decorated with white curvilinear slip decoration on the upper part of the body. The use of slip at this period is uncommon in Buckinghamshire but it has been noted on pitchers at a twelfth to thirteenth-century site at Ashampstead in Berkshire (Mephram & Heaton 1995). Also present were 'cooking pots with squared turned out rims and 'shallow pans or skillets with flat bases and round hollow handles.' Some of the material is in the County Museum (188.64 and probably 100.65). The only find from the site recorded in detail is a stamped lead-glazed tile with a floral decoration (Hurman 2004), a design previously noted by Hohler (1941 and 1942) and others. The same article includes a few lines on the other ceramic from the site, noting edge-glazed sherds (typical of a kiln site) and also describes a louver produced there. The article also notes some of the records for fifteenth-century tile making at Cadmore End and later at Lane End.

(b) A second area identified by Mr Smith which also came to light during construction of the Wycombe by-pass, a few hundred yards east of the previous site, produced a number of tiles glazed together. Thought at the time to be a tile kiln, this could also be another pottery kiln whose walls were of tile (HER 4622. SU 795 926).

(c). A further collection of pottery including wasters was found by Mr Smith in 1968. In a subsequent conversation he said that the material came from one of many trial holes he had dug on the common north of the motorway [HER 0898; SU 796 928]. Some of the pottery is now in the County Museum (115.74). It is now thought to date to the fifteenth to seventeenth centuries. A photograph by Mr Boarder shows waster material found by Mr Smith on Cadmore End Common (HER 00098). An accompanying map drawn by Mr Boarder marks 'pottery kiln' and is presumed to be the find site.

#### Potters

1714. Richard Dennis, potter, of 'Lane End in the parish of Marlow', bequeaths 'all my pots,

pans and pot earthenware and all working tools and implements belonging to the pot trade.' (CBS 55/89 and 68/160).

1798. John Druce and John Sears are recorded as potters in Great Marlow parish in the *Posse Comitatus* (Beckett 1985, 234). It is possible that these were Fingest/Lane End potters (note a Sears at Lane End below).

1851 Census:  
Joseph Slade (42), potter, Lane End b. Coleshill, Gt Marlow.  
George Sears (51) pot hawker, Wheeler End, West Wycombe.

1861 Census:  
William Carter (30), potter at Lane End, b. Penn Street. Previously an agricultural labourer at Winchmore Hill. By 1871 he is potting at Cookham, Berks (Ce).

Alfred Gray, potter, Fingest.

The census includes several brick and tile makers  
1862. Sheahan (1862, 899) notes of Lane End, 'Here, too, is a *Pottery* for coarse brown ware'.

1864. Samuel Sears chair manufacturer, grocer and potter, Lane End. *Kellys*.

1865. Samuel Sears, 'a small pottery belonging to Mr Samuel Sears. *Kellys*.

1869. Samuel Sears potter. *Kellys*

1871. Census (Lane End Common):  
Richard Piercey (30), potter, Lane End Common, b. Nettlebed [a family name at Nettlebed, Oxon].  
Frederick Pearcey (17) potter. Lane End, Gt Marlow. b. Nettlebed [by 1881 he was a tilemaker at Pinkneys Green, Berks].

Richard Faulkner (70) potter, Lane End Common, b. Great Marlow.

1877. Samuel Sears, chair and pottery manufacturer and grocer, Lane End. *Kellys* refers to a 'small pottery'.

1881. No potters are recorded at Lane End in the census, although there were brick-makers. No potters are referred to in the 1883 *Kellys*.

**Gawcott***Potters*

Timothy Brisk is recorded as a potter in the *Posse Comitatus* of 1798 (Beckett 1985, 97). No other information is available.

**Gerrards Cross** (see Chalfont St Peter)

**Great Brickhill***Kilns*

Wasters are present amongst sherds deriving from land immediately adjacent to Jack Ironcap's Lane. A high proportion of quartz grains make the ware distinctive. Products include jugs, bowls, jars/ cooking pots and bunghole vessels. Discoveries of the ware elsewhere suggests a date of production between the fourteenth and fifteenth centuries (Beamish 1989). Slowikowski (2011) classifies its products as 'Late Medieval Reduced Wares' which can be paralleled at a number of production sites in Bedfordshire.

*Indicative Names*

Jack Ironcap's Lane (see above) was formerly known as Potters Lane (Beamish 1989, 88). There is a reference to a message in Potters Lane Close in 1755 (D-DU/2/485).

**Great Kimble**

In 1946 a vessel was accessioned by the County Museum, being described as 'Earthenware jug. Eighteenth cent. Made by T. Bray, Kimble. Donor F.W. Rutland, Risboro' Rd, Gt. Kimble' (Acc. 1946.22). That it was *made* by T. Bray at Kimble may be questioned. On the front are the words 'T. Bray' with 'Gt Kimble' beneath. No further information about any potters of this name has come to light.

At first sight The Kimbles (Great and Little) seem an unlikely place for a pottery. However, there is a slight potting connection with the parish. In 1766 a licence was granted for the marriage of Moses Hubbocks, potter, of Great Kimble [possibly his birthplace] and Sarah Shiperlee of Brill, at Brill (D-A/M/ H 1217). Both surnames occur as longstanding Brill potting families. As their marriage was taking place at Brill rather than Kimble, it might be that Moses was born at Kimble but did not ever work there. In 1780 the

parish registers of Kimble record the marriage of an Edward Baker to an Elizabeth Hubbocks (who could have been a younger sister of Moses), so although the Hubbocks family has a history at both places there is as yet no firm evidence that they potted at Kimble.

In 1814 a Thomas Bray was baptised in 1814 at Great Kimble. It is possible that the pot is a nineteenth-century piece rather than an eighteenth-century one, and that it was a Brill pot commemorating his baptism.

**Great Marlow** (and see Fingest and Lane End)

*Kilns*

The earliest slight indication of a pottery within the parish occurs in a place name within the town (see below). Great Marlow parish extended up to a cluster of commons near Lane End where parish boundaries were unclear, more than one potter being described as of 'Lane End in the parish of Marlow'. Because of uncertainty about the precise location of the Lane End potters they are included under the modern Fingest and Lane End parish entry. There is, however, no doubt about the location of the Medmenham Pottery.

In 1897 the Medmenham Pottery was established at Marlow Common (SU 8247 8675) adjacent to a brickworks in Davenport Wood, and probably initially using a brick kiln (OS 6" 51NE 1900 edit: HER 4757). The enterprise was funded by Robert Hudson of Sunlight Soap fame, the builder of *Danesfield*. The pottery was under the directorship of Karl Dressler (1856–1940) who trained as a sculptor at the Royal College of Art and had earlier set up a foundry in Chelsea, having gained a reputation as a portrait sculptor. He also worked at the Della Robia pottery in Birkenhead and was a follower of Ruskin (Trusted 1996). In accordance with Ruskin's principles the Medmenham pottery used local clay and where possible also local labour, although according to one contemporary writer 'He finds the human material less promising than he had hoped' (Miller 1900).

At Medmenham, Dressler produced 'tiles and figures for both interiors and exteriors of buildings, such as the Law Society, Chancery Lane, and the Sunlight Chambers in Dublin, as well as garden statuary' (Trusted 1996). A number of other locations had Medmenham tiles including The Hospital for Women, Soho Square (Greene 1987)

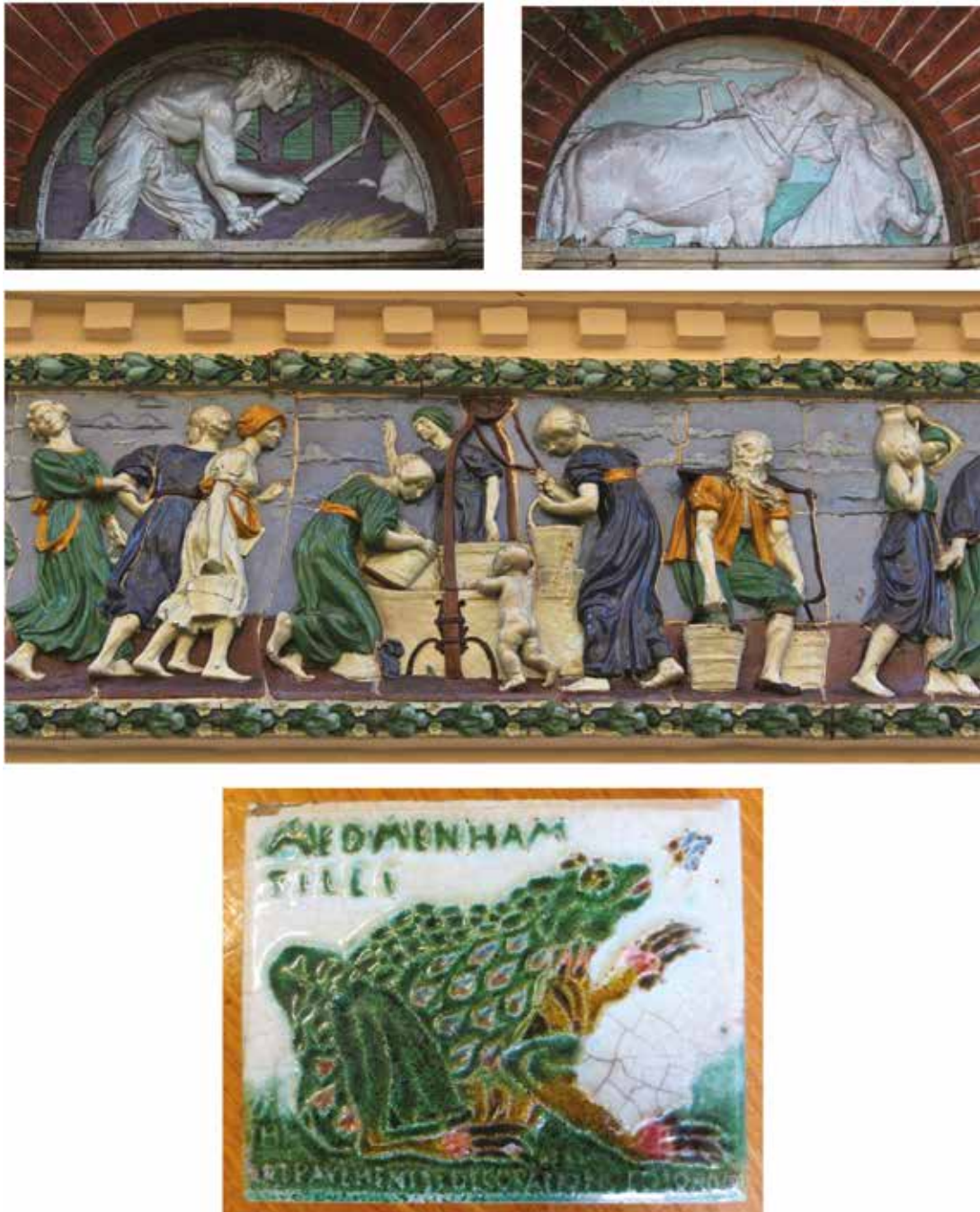

FIGURE 37 Top: tiles made at the Medmenham Pottery for specific buildings around Medmenham. The upper two are above doorways in buildings at Westfield Cottages, the central image is part of a larger frieze at Monk's Corner. The single tile at the bottom is in the County Museum collection (1993.135)



and ‘some of the bath-rooms in the new Grand Central Hotel’ (Miller 1900, 173). They were showcased at the premises of Dressler’s London agent, Hoffer, in Soho Square (Myers 1984; Herbert 1985). Colourful relief tiles (Fig. 37) were a particular speciality. Locally they were built into Monk’s Corner, Marlow Common (Dressler’s own house), Westfield Cottages, Medmenham (Plaisted 1925, 314–5), Robert Hudson’s home at *Danesfield* (Anon c.1985; Pevsner & Williamson 1994, 469), as well as a number of other buildings in the area (Walker 1986, 9–10).

F. Miller, who wrote a piece on Medmenham in 1900, contributed a later but undated supplement to the *Art Journal* on the same subject, in which he records that the business was struggling and that Dressler had to pull down kilns in order to replace them with others that ‘should do their work more economically’ (for a photograph of the last kiln see Walker 1986, 9). In c.1908 the business moved to Staffordshire, where it must have operated under another name, as the name has not been noted there (information from City Museum & Art Gallery, Stoke on Trent in 1980).

Some pieces from Medmenham are in the County Museum. There is a growing literature on Medmenham, not all of which can be listed here. One of us (BMH) intends to deposit the results of her own study with the County Museum.

### *Potters*

The Medmenham potters have not been researched in detail, but the 1901 census records Conrad Dressler, sculptor and potter, employer, who lived with his wife, son, a boarder and two servants at The White House, ‘The Potteries’. His workers included Angelo Poggi, potter’s earth artist (born Italy), Erdith [*sic*] Jones (17), painter [deleted] sculptor (artist), Samuel Todd, potter’s earth labourer – worker, and Alfred Thorne, earth pottery worker, Mary S Florence (43) painter, sculptor, artist, Lords Wood, Kate E Hillesden (16), painter in pottery earth, Lords Wood, Herbert Hawes (30) journeyman painter, Charity Farm. In 1910 Conrad Dressler (44) still lived at The White House (Ce).

### *Indicative Names*

A message in the High Street, Great Marlow and ‘two closes of arable land known as Pottlands’ are noted in a mortgage agreement of 1686 (Jenkins 1941, 38. 352/22 No. 8).

## **Great Missenden (Potter Row)**

### *Kilns*

a) In seeking evidence for a medieval industry here (below), Mrs J. Taylor and Mrs D. Waterton unexpectedly located instead seventeenth-century waster material in a garden at Potter Row. The presence of a few pieces of glazed brick amongst the pottery suggests that the kiln was brick-built. The clay used was light in colour and its source is not known. Products included pipkins, small bowls, plates and jars. There was a single example of a bleeding bowl and two fragments of chafing dish. The handles found may have been from skillets. Glazes range from clear honey-coloured to green. A distinct feature of the assemblage was the presence of quite complex decorative stamp decoration used on rims and the interior of some bowls (Fig. 38). (Buckinghamshire County Mus. Arch. Group 1978).

b) Following the discovery of the undocumented post-medieval industry at Potter Row noted above, Mrs M. Hall and subsequently other members of the County Museum Archaeological Group located medieval pottery wasters. All the pottery was in a sandy quartz-tempered fabric, typical of Chilterns products. Three fabric sub-divisions were noted and it was suggested that these might indicate a range of dates. However, wasters could only be clearly identified amongst the glazed material, which it was suggested could be late in the sequence. Identified products included cooking pots, jugs, bowls/jars. Traces of green glaze were present on both jars and bowls. The whole is dated to the fourteenth/fifteenth centuries (Ashworth 1983).

### *Indicative Names*

A pottery industry was indicated by the place name ‘Le Potterewe’ in 1311 (Mawer & Stenton 1969, 156) and the earlier presence of a Peter Pottarius whose land was recorded in connection with a grant to Missenden Abbey in 1234–52 (Jenkins 1938, no 50).

## **Hanslope**

A kiln discovered at Gordon’s Lodge Farm (SP 775 485) and locally claimed to be a pottery kiln was investigated by R.A. Croft in c.1980, but no wasters or kiln debris were located. It is thought to have been a domestic or agricultural kiln.

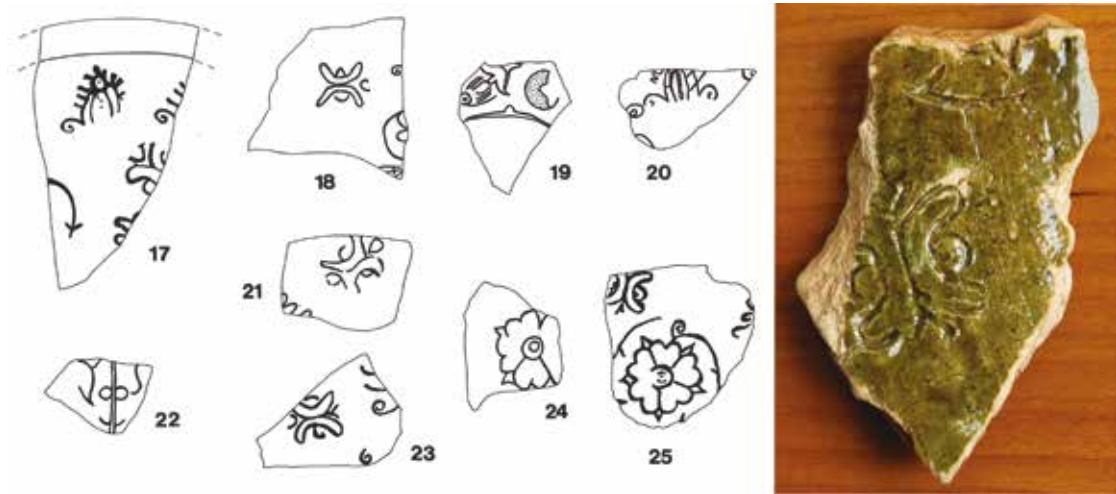

FIGURE 38 Distinctive stamps on plates from Potter Row, Great Missenden; probably of seventeenth-century date, and a Potter Row sherd, excavated from nearby Missenden Abbey

## Hartwell

### *Indicative Name*

An index of names of thirteenth to sixteenth-century date in Hartwell charters, rentals etc. (Elvey 1978) includes a number of references to 'Potters Lane' (CBS typescript). The following example of 1490 (no. 154 (691), 'feoffment of a tenement between Cheyniswyk and Potters Lane... in the field of... [Southcote/Southrope]', suggests that the lane is in the southern part of Hartwell.

## Hedgerley

See Farnham Royal for a general note on boundary changes affecting the identification of potteries here.

Two areas within Hedgerley had potteries:

(a) Hedgerley Green. The Green lies at the northern end of the parish, formerly close to Beaconsfield Common and a little north of Stoke Heath (Jefferys 1770), and now just south of the M40. There are today a few houses around the green and some ponds which might be infilled pits. Notably, a number of Roman pottery kilns have been identified only c.200m north of The Green (HER 1523, 1531 & 2145). The hamlet was 2km from the Beaconsfield Pottery (see Chalfont St Peter). Only one potter has been located here.

(b) Hedgerley Hill. This is the principal road ascending southwards from the village centre towards One Pin crossroads. There was a sequence of potters working here, probably on the same site, the first being recorded in 1723 and the last in 1786. An entry in 1815 indicates that a kiln (whether operational or not) was still present.

### *Kilns*

(a) Hedgerley Green

No kilns have been located here, but see Potters entry below.

(b) Hedgerley Hill

1815. Churchwardens account books note 'Pd for footbridge by Pot Kiln 2-11.0d' (Rice 1980, 21). Rice (*in litt.*) notes that 'The footbridge referred to was on the roadside alongside Pot Kiln Mead [see below]. There was a pond on the other side of the road which flooded in wet weather. This pond was filled in by the County Council during the 1950s and the road and nearby properties still flood in extreme weather.'

The 1842 Tithe Map (CBS No. 208) shows 'Pot Kiln Mead' in the occupation of Thomas Nash and under grass (plot 15). By this time the pottery business had long ceased. The 1875 survey 25'' OS map shows buildings here fronting the road (SU 9684

8662) but none can be certainly identified as pottery-related.

- c. 1920s. ‘View of Pot Kiln cottages, Hedgerley Hill with the Post Office in the centre.’ (Rice 1980, 59).

We are grateful to Michael Rice who informs us that ‘...my wife’s family lived in one of the new houses which were built on the site of those cottages in the early 1960s and my mother-in-law tells me that when they moved in, the gas meter was labelled 3 Pot Kiln Cottages.’

### *Potters*

#### (a) Hedgerley Green

Only one potter can be firmly located here.

1806. William Devonshire, potter of Hedgerley, was declared to be the only person possessing rights of common on Hedgerley Green in a land transaction involving creation of a pleasure ground (D-RA/1/99: n.b. small marginal map).

1813. William Devonshire, potter, Hedgerley Green, was a witness at a court hearing. (Justices Case Books. QS/JC/2. Epiphany 1813).

#### (b) Hedgerley Hill

A 1785 churchwarden’s note (below) allows James Wright to be located here, and in turn an earlier sequence of potters of whom Benjamin Peusley (below) is the first.

1723. Benjamin Peusley, potter, Hedgerley buys two acres of land in the parish from Henry Cobsell of Burnham, ‘abutting and bounding south-east upon Black Grove and west on a lane a highway leading down from Farnham Common to Hedgerley Town’ (D/RA/2/317). This is likely to be the Benjamin Pusey later noted by Rice (2008, 155) as being ‘prominent in village affairs’ and a signatory to parish accounts, a situation unusual for a potter. As there is no mention of a kiln in the purchase Peusley may have established this pottery.

1756. Benjamin Pusey of Hedgerley, ‘bequeaths to his son-in-law Thomas Bagley and Sarah his wife... likewise the pot kiln with the shop and drying houses belonging to the

pottering trade together with the wheels and working tools and all the utensils thereto belonging’ (DAWE 86/76, 1756).

1756. Thomas Bagley, Hedgerley (see above).

1759. Thomas Bagley, potter of Hedgerley and Sarah his wife, are parties to a copy lease referring to land formerly belonging to Benjamin Pusey late of Hedgerley, potter, deceased, the pot kiln and shop thereto belonging’ ( D-RA/2/317–8 also D RA/2/220–1). The land abuts Black Grove.

1761. Thomas Bagley has his will recorded (Kidd 1993, 71). After his death his pottery is initially occupied by James Wright (below).

1765. James Wright. In 1765 Thomas Dell, a poor child of the parish’ was apprenticed to Wright (PR 14/14/87).

- ?1760s–70s. George Percy [probably Piercey, see below] was another employee of James Wright. Percy was later himself ‘renting a house and two pottery kilns for a yearly rent of ten pounds’ (Rice 1980, 10, 26).

1773. James Wright. Sarah Bagley, wife of Thomas Bagley, bequeaths her inherited messuage or tenement ‘...with the Pot Kiln, Drying Houses, Stable, Orchard and Garden adjoining thereto as to the same now are in the occupation of James Wright Potter situate in Hedgerley aforesaid...’, to a Thomas Street, then a hurdlemaker. She also bequeathed the sum of £5 each to three potters including James as above, but also Nathaniel Pusey and George Piercey (Rice 2006, 157–8).

1773. George Piercey and Nathaniel Pusey noted as potters (see above). George probably worked for James Wright, see below.

1780. Thomas Street, who inherited Bagley’s kiln (above), might himself have either taken up pottery or alternatively leased the business. Subsequent to Sarah Bagley’s bequest he remains in possession of the property with a pot kiln in a boundary dispute with another beneficiary of Sarah’s will (Rice 2006, 10).

1785. Churchwardens’ accounts note a settlement order for George Percy [probably Piercey above] who ‘was hired by James Wright, a potter of Hedgerley, with whom he worked for two years. He stated at an examination that “he worked in the pottery business during the day but always slept in the

hamlet of Farnham Royal during the night”.  
(Rice 2006, 41)

1785. Churchwardens’ accounts refer to James Wright potter of Hedgerley Hill. He appears to be the last recorded potter here. He died in 1786 (Rice 1980, 10–11 and 26).

### High Wycombe

#### *Potters*

Ashford (1960, 38) records a thirteenth-century reference to a burgess called Robert the Potter. However it should be noted that a perambulation of ‘Chepping Wycombe’ in 1820 (Parker 1878, 40–41) included Potter’s Cross at Penn.

1881. William Willmot, potter, resided in Wycombe (Ce). It seems likely that he would have been employed at Hedgerley, Chalfont St Peter or Lane End potteries.

### Iver

#### *Potters*

Bailey (2009, 179) notes a John Pottere in the 1379 Poll Tax. The name need not indicate an occupation by this date.

#### *Indicative Names*

Potters Cross. Rocques Map c.1760 marks Potters Cross north of Iver on the edge of Iver Heath. The 25” OS map of 1875 (Sheet LII.12) marks the name beside buildings just south of the crossroads at TQ 0308 8296. The area is now under housing. Although the name may not indicate the presence of a potter here, at Penn the same descriptive name is adjacent to a production area.

**Lane End** (see Fingest and Lane End)

**Latimer** (see Chesham)

### Leckhampstead (Whittlewood)

The commissioner’s entry for Leckhampstead in the *Rotuli Hundredorum* I (folio 33b) of 1254–5 relating to Whittlewood [Forest], notes that no forester has a *rogus* or a *furnus*. One translation of *rogus* is ‘potter’s oven’ [kiln] (Latham 1965), and *furnus* as being some other fire-related installation which could at one end of the scale be a bread oven and the other an iron smelting furnace.

It may seem perverse to note references to items that foresters did *not* possess, but it is feasible that the entry was necessary since other unrecorded individuals in Leckhampstead, or nearby, did possess them. To put the terms *furnus* and *rogus* in the context of other local forests, Bernwood, as previously noted, certainly had potters and fieldwork has also shown ironworking here. Rockingham Forest in north-east Northamptonshire likewise had both potters and ironworking, and Foard (1991) notes that the two industries worked in close proximity. Although there is no evidence for ironworking within Whittlewood Forest the Northampton Sand Formation outcrops close to Towcester, which was on its northern margins’ and the same formation was worked a little distance to the north-west of the town at Byfield (Sutherland 2003, 34–36). It is therefore possible that the presence of iron working in Whittlewood could provide an explanation for the *furnus/rogus* references. However, at Brill (see above) the *Rotuli* specifically notes that the *furnus* of Peter was for making pots, so it appears that the terms were not exclusive and the commissioners may not have been consistent in their terminology.

Although the above leaves the case uncertain, there is some evidence for potters in, or close to, the forest, which lends strength to the argument in favour of their kilns being present here. Six kilometres to the north-east of Leckhampstead, on the eastern margin of the forest, is the aptly-named village of Potterspury, where there were a considerable number pottery kilns, both here and in adjoining Yardley Gobion (e.g. Jope 1950, Mynard 1970, Jope & Ivens 1995 and Northamptonshire HER entries), so it might be these potters who occasioned the oblique reference. However, there is other evidence supporting the existence of pottery kilns not far from Leckhampstead. During a programme of research on Whittlewood, the discovery of a dump of pottery sherds, all of similar fabric (quartz, fossil shell etc.) was recorded during construction of a parking bay in a front garden, 8km north-west of Leckhampstead at West End, Silverstone. The pottery was dated to the first half of the thirteenth century or possibly earlier. It was recorded by Paul Blinkhorn, who noted that some of it was ‘scorched and spalled’. He concluded that; ‘Overall, there seems to be therefore a good case for describing this deposit of pottery as the waste from a manufactory’ (Blinkhorn 2001). There was certainly a potter working at Dadford in the

parish of Stowe in the thirteenth century (below), possibly one at Lillingstone Dayrell (see below) and in the parish of Akeley adjacent to Leckhampstead (above) there is an eighteenth-century reference to a ‘Potteres Hooke’. It is freely admitted that this associated cluster of evidence only flags up the possibility that pottery production may have been a significant element of the Whittlewood forest industries, but it seems worthwhile to bring it to notice here.

### Lillingstone Dayrell

#### *Indicative Name*

1288–9. ‘...dimidia acra apud Croxforde’ and ‘...j acra super Croxfordhul’ (Elvey 1975, 421).

### Little Brickhill

Mynard (1975) describes the re-investigation of two kilns producing slip-decorated floor tiles. A brass in Great Linford church of the late fifteenth century when the floor was relaid with Little Brickhill tiles provides a close date for their production (Mynard, *in* Mynard & Zeepvat 1991, 211). Tiles of some kind were still being produced at one of the Brickhills in 1527 (Vere Woodman 1960, 311). Apart from tiles no other ceramic finds are described, but as domestic ceramic was also produced at both Penn and Boarstall, which also produced decorated tiles, and as pottery production has been noted at the adjoining village of Great Brickhill, it is possible that there was pottery production here also.

### Little Missenden

#### *Potters*

1854. Clarke, Joseph, potter, auctioneer and farmer, Kings Hill (*Kellys*).

As this is the only reference to a pottery here it seems likely that Wright may have been working part-time in one of the Chalfont potteries

### Loughton

#### *Indicative Names*

A glebe terrier of 1639 notes ‘one half acre butting into Potterswaye land.’ and ‘one half acre between Portwaye and Potterswaye ...’ in Secloe Field (Reed 1997, no. 80). A map of ‘Loughton Fields in 1769 (CBS IR/143R) has ‘The furlong between

Portway and Potters Way.’ ‘Portway’ led from Loughton village towards Bradwell Common; ‘Potterswaye’ itself is not marked. The furlong was at c.SP 8500 3850.

### Ludgershall

#### *Kilns*

An evaluation and subsequent excavation in advance of construction of two houses in Duck Lane uncovered a large quantity of kiln waste, both of pottery and tiles of mid to late fifteenth-century date, but no kiln structure. It is presumed that there were kilns nearby. The products are in the Brill-Boarstall tradition. They included ‘jars or bung-hole cisterns, bowls/pancheons and jugs, a lug from a costrel and a ginger jar rim’. A few of the pancheons had rosette-stamp decoration on the rims. Glazing was generally ‘scarce’. Some ‘Tudor-green’ types were present, ‘primarily lobed cups or mugs’ but, interestingly, no saggars which might be expected with small glazed vessels such as these (Blinkhorn & Saunders 2002/2003).

### Maids Moreton

#### *Potters*

1847. Wm. Sanders, potter and tile maker. *Slater’s Directory*

There is no further reference to Sanders here but in the 1851 census a William Saunders, potter, was living at Akeley and it is apparently he who establishes the Akeley pottery. There seems little doubt that Sanders and Saunders are the same person. It may have been a directory error unless Saunders worked briefly in Maids Moreton before moving to Akeley.

#### *Indicative Names*

The place name ‘Potters hooke’ occurs on an estate map of 1595 (BRS 1964, map 3). Its present position would be c.SP 713 384, where the Foxcote reservoir is now.

### Medmenham (see Great Marlow)

### Mursley (Salden)

#### *Indicative Names*

Salden, a hamlet of Mursley, was initially the seat of two manors (VCH 4, 51). A perambu-

lation of the fields of Salden taken to identify land belonging to Luffield Priory, dated ‘probably shortly after 1252’, notes ‘et tunc vi seliones que iacent ex utraque parte de Crokkeswey decime de. L.’ (Elvey 1975, 214).

### North Crawley

#### *Potters*

1865. James Cave, builder and contractor, brick and tile maker and potter, Wren Park, Brickworks. *Cassey’s Directory*. His description as a potter in this directory seems an anomaly, as in the 1851–1881 census he is always described as a bricklayer or builder.

#### *Indicative Names*

Potters Corner 1779 (Enclosure Award, BAS DAW/1 22/61).

### North Marston

#### *Potters*

1756. ‘Ricket, Joseph of North Marston pottman’ ... ‘being sick and weak in body’. In his will

he bequeaths to his wife his land and ‘all my stock of trade’ (CBS: DAWE 86). As Ricket is not specifically called a potter, he could have been a trader in pots.

### Olney Hyde

#### *Kilns*

Thirteen probable kiln sites have been identified at Olney Hyde (a former medieval hamlet) by surface scatters of sherds. Two of them have been confirmed by excavation and two by geophysical survey (Mynard 1984). Kiln 1 (partly excavated) was within an area of limestone cobbling on a medieval croft and adjacent to the footings of an L-plan building. It was excavated in 1967. The north range of the building contained features including a pivot stone, possibly for a potter’s wheel, which led to its being interpreted as a potter’s workshop. Apart from the kiln, also within the yard was a possible clay storage pit. A smaller excavation in 1969 examined Kiln 2 which lay a little west of the first. Both kilns were of the single-flue updraught type with central pedestals, and were built of limestone (Fig. 39).



FIGURE 39 Fourteenth-century limestone-built kiln at Olney Hyde

Two kinds of pottery fabric were identified, A and B. Fabric A, probably earlier than B, was probably not produced at either of the excavated kilns but at a kiln identified only from surface scatter some distance to the south-east. It contained plentiful small pieces of limestone and is thought to date to the mid-twelfth to late thirteenth centuries. Fabric B, produced at the excavated kilns, contained sparser limestone and the surface is coarser to the touch. It is dated to the fourteenth century. Vessels produced in Fabric A included cooking pots, bowls and a few jugs. Decoration was not common. Vessels produced in Fabric B included the forms above but more jugs than in the earlier fabric and decoration was more common. Its range also included bottles, lamps mortars, curfews and also some ridge tiles and chimney pots (Fig. 40).

The village within which the kilns were situated was substantially depopulated in the fourteenth century when it became a park. It has long since been levelled by ploughing.

Subsequent to the kiln excavations, Olney Hyde type pottery has been found on a number of excavations in Milton Keynes and this has enabled

some re-assessment of its date, forms and fabric types (e.g. Mynard & Zeepvat 1991, 253, 259).

### **Penn**

The hamlet of Penn Street (see Amersham above) should first be noted. It lies within Penn parish a little over a kilometre north-west of Winchmore Hill and about two kilometres from the village of Penn itself. The ecclesiastical parish of Penn Street was formed in 1850 (*Kellys* 1877).

There is certainly one potter who is recorded here (William Carter, described as a master potter) and there may have been others, but it has not proved possible without further research to distinguish between a number of potters who may have worked in this hamlet and those who lived here and worked in the Winchmore Hill complex (see discussion under Amersham).

No kiln site has been yet located at Penn Street. However, we are grateful to Miles Green (*in litt.*) who comments ‘The common land outside the gates of Penn House and opposite Penn Street Farm is dominated by a large claypit and two ponds, which... was the result of a century or more of the activity of a large works on the other side of the



FIGURE 40 Restored jugs from the Olney Hyde excavations

road that was making bricks, tiles and pottery for at least a century from the 1770s. One of the fields next to Penn Street Farm on the 1838 Penn Tithe map was Kiln Slip'. The census returns seem to indicate that the dominant industry here was brick making not potting.

A short distance west of Penn parish church is Tylers Green. Tiles were being produced here from as early as 1222 (Hohler 1941 & 1942; Green 2005, 118; Zeevat 2009) and the area is well-known for its production of decorated floor tiles in the fourteenth century. However, in recent years the same general area has also been recognised as a medieval to early post-medieval pottery production area, although this aspect of the industry has received less attention. There is one item of documentary evidence which may support this.

#### *Kilns*

(a). An extensive field scatter of roof tile and some floor tile was associated with waster pot sherds, probably of fourteenth-century date. Products included jugs, bowls and jars. Only the jugs had evidence for glazing. The site, south of Ashwells Manor and west of Tylers Green, lies west of the main area of production of the better-known decorated tiles (Cauvain *et al* 1989).

(b). A field scatter of pottery east of Tylers Green included wasters. Jugs, bowls and jars were produced. Glazing was present, predominantly on the interior of bowls and jars. The group is dated to the late fifteenth to sixteenth century (Hutchings & Farley 1989).

(c) Not far north-west of the above site, at Yonder Lodge, wasters of similar character and date were collected from a kitchen garden and an adjacent boundary (Hutchings & Farley 1989)

#### *Potters*

1368. A coroner's inquest relating to the death of the vicar of Penn records John le Potter as one of the jurors (Jenkins 1935, 64–5). Although John need not have worked in Penn it is clearly a reasonable possibility.
1734. See William Cordwell under 'Amersham'.
1841. William Carter (71), farmer, Penn Street. By 1851 he is recorded as 'master potter' (see below). However, in the same 1841 census William, curiously, is recorded at

Cookham Dean (Berks.) but as an agricultural labourer. Also at Cookham Dean, another apparent duplication, was Thomas Carter, an agricultural labourer here but also recorded as a potter at Coleshill Green! (Ce)

1850. William Carter. Earthenware manufacturer, Penn Street. *Slater's Directory*
1851. William Carter (81), farmer/master potter, Penn Street Farm. Employer of 21 labourers [their jobs not known]. Farmed 60 acres (Ce). Joab Carter (45) superintends his father's Brick Mafs (*sic*) at Penn Street.
1861. Joab Carter (55) farmer 120 acres [employing] labourers [at] kiln. (Ce)
1871. Joab Carter (66), farmer. He employed 6 men and 4 boys. As they are not specifically called agricultural labourers normal for farm workers, these may have been working at the kiln still. In 1881 he was described as a farmer and brickmaker (Ce).
1877. 'Job Carter' is listed in *Kellys* as a farmer, lime burner and brick manufacturer.

#### *Indicative Names*

Potter's Cross. The name occurs in a 'Perambulation of the ancient outward boundaries of the parish of Chepping Wycombe...' of 1820 (Parker 1878, 41). It appears on modern OS maps not far from Tylers Green (above).

#### **Quainton**

##### *Potters*

1295. 'Richard the Potter of Diddershull, acre of land in, grant', 10 April 1295 (D-/P/29).
1840. Indenture 'One yard in Crocker in Seech Field' (D 114/26/1–2).

#### **St Leonards** (see Aston Clinton)

#### **Seer Green** (see Farnham Royal)

#### **Shalstone**

##### *Indicative Names*

A letter relating to Shalstone manor dated 1737 notes: 'Your tenant Enox tells mee hee is to repair the rails on his side by Potford... My mother now 19 ewes and lambs in the Lower Rinehill next Potford' (Eland 1931, 43). A letter of 1746 to Browne Willis,



‘As to anything remarkable in Shalstone parish there is nothing that I know on, saving Potford, a little brook at the bottom of Waterstratford Hill in the road from Shalstone to Buckingham...’ (Eland 1931, 267). The name is recorded in both Shalstone parish and Water Stratford (see on).

**Slough** (see Upton-cum-Chalvey)

### Soulbury

#### *Indicative Names*

1769. ‘Crockendon Furlong’ adjacent to Crockendon, Cow Common’ shown on ‘A plan of the manor of Soulbury 1769’ (CBS: BAS Map 72). Centred at c.SP 8880 2800 (HER 2763).

### Stoke Goldington

#### *Indicative Names*

There is a reference to ‘kiln fields’ in Eakley Lanes, Stoke Goldington in 1744 (Horton Deeds, Northamptonshire Record Office ref G(H)902). Eakley lies north of Stoke Goldington on the edge of Salcey Forest and was a separate manor. The ‘Lane’ suffix probably arises from a family of that name recorded in 1658 (VCH 4, 469). I am grateful to Kim Taylor-Moore for this reference. These need not have been pottery kilns.

### Stowe

#### *Indicative Name*

There is no doubt that a potter was operating in the early thirteenth century or earlier at Dadford, a hamlet just north-west of the village of Stowe (now replaced by the well-known house). A reference in the Osney Abbey Cartulary of c.1230 refers to a potter’s clay pit: ‘Donacionem... Nicholai de Boycote... de sex acris terre cum una acra prati and cum pertinenciis in campis de Dodeford, scilicet una acra apud Longeheg, et una acra apud Potterescleypettes et una aera super Elrewe...’ (Salter 1935, V, nos. 755 and 755a). See Leckhamstead (above) for discussion of other possible potters in or near Whittlewood Forest.

### Upton-cum-Chalvey

#### *Kilns*

A ‘Slough Pottery’ is retrospectively noted in 1899 in Wellington Street (see below). Previously in 1883, William Lambert a brick and tile maker is also listed in Wellington Street (*Kellys*). This implies at least one kiln in the area but the 1875 survey OS 25” map shows only residential properties here. The road is now called Wellesley Road. Not far to the east on the other side of Wexham Road a brick kiln is shown on the 1875 survey which could have been Lambert’s premises although two other brickmakers are listed in the same *Kellys*.

#### *Potters*

1881. Charles West (36) pipe and tile merchant, Nelson Place, Upton-cum-Chalvey.
1883. Charles West. Garden edging, potter, pipe and tile stores, Wellington Street, Slough *Kellys*. [He may have employed two ‘potters’ below, see below.]
1887. Charles West is listed at ‘pottery store, Wellington Street’, *Kellys*. However in 1899 (see on) he is retrospectively described as a potter (ditto 1891)
1891. Henry Fowler (67) and George A Brown (25), both of Upton-cum-Chalvey, are described respectively as ‘Labourer in earth Pottery Yard’ and ‘Earth Pottery Labourer’ (Ce).
1899. In a *Kellys* advertisement, Phillips and Son describe themselves as ‘Successors to Charles West. Builders’ merchants, sanitary and horticultural potters. Slough Pottery, Slough’ (Fig. 41).
1903. Phillips and Son are still listed under potters (*Kellys*) and are still in Wellington Street until 1907.

### Water Stratford

#### *Indicative Names*

‘Putford Field is near the point which is now called ‘Potts Ford’ and spanned by a stone bridge, between Water Stratford and Shalstone parishes’ (Myres 1892). The same ford recorded in both Water Stratford and Shalstone (see above for Shalstone)

ESTABLISHED 1856.		
<b>PHILLIPS &amp; SON</b>		
SUCCESSORS TO CHARLES WEST Telegrams- <b>POTTERIES.</b> SLOUGH	<b>BUILDERS</b>	<b>MERCHANTS</b>
<b>Sanitary &amp; Horticultural Pottery.</b>		
<i>Slough Pottery</i> <b>SLOUGH.</b>		
<b>GOODS DELIVERED TO ANY PART OF THE KINGDOM.</b>  <b>SAMPLES, PRICE LISTS, ESTIMATES, &amp;c., ON APPLICATION.</b>	<b>Portland &amp; Keene's Cement, PLASTER OF PARIS, PLASTERERS' HAIR AND LATHS.</b> <b>.. SLATES ..</b> Of all Sizes and Qualities. Chimney Tops of all descriptions. <b>GREY STONE LIME, BLUE LIAS LIME.</b>	<b>WINDOW ARCHES AND SILLS, FIRE BRICKS, FIRE TILES, FIRE CLAY.</b>  <b>Horticultural Pottery.</b> Flower Pots, Seed Pans, Wall Pots, Rhubarb and Seakale Pots. <i>Rustic Ware Vases, Window Boxes.</i> GARDEN EDGING TILES, Pans, Bowls, Stone Bottles, Jars, &c.  <b>RED AGRICULTURAL DRAIN PIPES.</b> Road Flints, Gravel, Silver Sand, Peat, Loam, Salt.
<b>GOOD QUALITY. LOW PRICES. PROMPT DESPATCH.</b>		

**MANUFACTURERS OF**  
**Glazed Stoneware**  
**Drain Pipes,**  
 Gullies, Interceptors,  
 Channels, and all  
 Specialities in  
**Salt-Glazed and**  
**White Enamelled**  
**SANITARY WARE,**  
 Sinks, Closets,  
 Lavatories.  
**BUFF, RED & BLUE**  
**FACING BRICKS.**  
 MOULDED BRICKS.  
 White Glazed & Coloured  
 Enamelled Bricks.  
**Brown Salt-Glazed**  
**Bricks.**  
 Architectural . .  
 . . Terra Cotta  
 In all its Branches.

FIGURE 41 Advertisement of 1899 for Phillips and Son 'Slough Pottery'

**Wooburn***Indicative Name*

1706. Conveyance '3 acres in Meadslow furlong Westfield and 1 acre in Potters Furlong, Southfield in Wooburn' (D/186/65).

**Wraysbury***Potters*

1881 & 1891. James Doulton, potter (Ce). As there is no other evidence of a pottery here he may have just resided here. Doulton is of course the name of a well-known potting dynasty who had a works in Lambeth.

**West Wycombe***Potter*

1221. 'In def(ectu) 1 pottar (ii) 12d'. The late Herbert Green kindly supplied this reference from the Bishop of Winchester's Pipe Roll (7, Roches, No 159271). He notes that the going rate for an acre was 4d, suggesting a holding of 3 acres.

**Wolverton** (and see Calverton)*Indicative Name*

A grant of land in *Potterwelleforlong* c.1230-1248 (Elvey 1975, no 347). We are grateful to Keith Bailey for this reference.

**Winchmore Hill** (see Amersham)

**Wotton Underwood**

*Indicative Name*

1649. Crockers Hedge Furlong (CBS: BAS Maps 87) at c.SP 6895 1568.

**BIBLIOGRAPHY**

Akeley History Group & Akeley Parish Council 2001 *Akeley: Past Times*. Northward Press (Buckingham)

Aitken MJ & Weaver GH 1962 'Magnetic dating: some archaeomagnetic measurements in Britain', *Archaeometry* **5**, 4–24

Anon nd. *Amersham Parish Registers 1561–1812* (Typescript CBS)

Anon 1923 *A Catalogue of the Principal works of Art at Chequers*. (HMSO)

Anon c.1939 *Archives of the Queen's College, Oxford* **2** (University Typewriting Office, Oxford: Bodleian ref 784a/2)

Anon 1982 Bucks tiles survive, *Glazed Expressions: Tiles & Architectural Ceramics Soc*, Summer 1982, 2

Ashford LJ 1960 *The History of the Borough of High Wycombe from its origins to 1880*.

Ashworth H 1983 Evidence for a medieval pottery industry at Potter Row, Great Missenden, Buckinghamshire, *Recs Bucks* **25**, 153–159

Bailey K 2009 Buckinghamshire poll tax records 1377–79, *Recs Bucks* **49**, 173–187

Beacs Hist Soc 1973 *The Beaconsfield Parish Registers 1600–1837*. Beaconsfield & District Historical Society

Beamish HF 1989 A medieval pottery production site at Jack Ironcap's Lane, Great Brickhill, *Recs Bucks* **31**, 88–92

Bedfordshire County Council & Royal Commission on Historical Monuments (England) 1979 *Brickmaking: a History and Gazetteer. Survey of Bedfordshire*. Bedfordshire County Council.

Beckett IFW 1985 *The Buckinghamshire Posse Comitatus 1798*. Bucks Record Soc **22**

Bennell J 1964 *Notes towards a History of Chalfont St Peter* (Typescript CBS)

BFWI 1987 *The Buckinghamshire Village Book*. Buckinghamshire Federation of Women's Institutes, 9–10. Countryside Books (Newbury)

Blackmore L & Pearce J 2010 *A dated type series*

*of London medieval pottery; Part 5. Shelly-sandy ware and the greyware industries*. *Mus London Archaeol Monog* **49**

Blinkhorn P 2001 [http://ads.ahds.ac.uk/catalogue/adsdata/arch-458-1/dissemination/PDF/Reports/Archaeological\\_Reports/Specialist\\_Reports/A\\_-\\_Specialist\\_Report\\_-\\_Silverstone\\_Pottery.pdf](http://ads.ahds.ac.uk/catalogue/adsdata/arch-458-1/dissemination/PDF/Reports/Archaeological_Reports/Specialist_Reports/A_-_Specialist_Report_-_Silverstone_Pottery.pdf)

Blinkhorn P & Saunders MJ 2002/3 A late 15<sup>th</sup>-century manufactory of the Brill/Boarstall pottery industry at Ludgershall, Bucks, *Med. Ceramics* **26/27**, 131–141

Blinkhorn P 2012 *The Ipswich Ware Project. Ceramics, trade and Society in Middle Saxon England*. Med Pottery Research Group Occ Paper **7**

Boarder A c.1974 *Photography of archaeological features in the southern Chiltern Hills*. Manuscript record with HER 00898

Boatwright L (ed.) 1994 *Inquests and Indictments from late fourteenth-century Buckinghamshire. The Superior Eyre of Michaelmas 1389 at High Wycombe*, Bucks Record Soc **29**

Brackley HR & King FK 1965 The potteries at Buckland Common, *Recs Bucks* **17**, 414–5

Broad J 1997 The smallholder and cottager after disafforestation – a legacy of poverty? in J Broad & R Hoyle (eds) *Bernwood; the life and afterlife of a forest*, 90–107. Harris Paper Two. University of Lancashire

Bryant 1825 Map of the County of Buckingham from an actual survey in the year 1824, by A Bryant 1825: in *Buckinghamshire in the 1760s and 1820s: the county maps of Jefferys and Bryant*. Reprinted Bucks Archaeol Soc 2000

Bucks County Museum Archaeol Group 1978 'A seventeenth-century pottery at Potter Row, Great Missenden', *Recs Bucks* **20**, 586–596

Cauvain S & P 1979 The products of a post-medieval pottery kiln from excavations at Emmanuel Church, Chesham, *Recs Bucks* **21**, 90–97

Cauvain P & Cauvain S 1992 Post-Medieval pottery kilns at Emmanuel Church, Chesham, *Recs Bucks* **34**, 61–77

Cauvain P, Cauvain S & Green M 1989 Prehistoric, Romano-British and fourteenth-century activity at Ashwells, Tylers Green, Bucks, *Recs Bucks* **31**, 111–119

Chaffey J, Dupre J & Wells M 1988 Medieval pottery from Botley Road, Ley Hill, *Chess*

- Valley Archaeol Hist Soc J*, 13–19
- Chaffey J & Wells M 1989 Distribution of Medieval & post-medieval pottery in the Leyhill area, *Chess Valley Archaeol Hist Soc J*, 27–29
- Chenevix Trench J 1973 Coleshill and the settlements of the Chilterns, *Recs Bucks* **19**, 241–258
- Chenevix Trench J 1977 Fields and farming in a hilltop village, *Recs Bucks* **20**, 410–428
- Chenevix Trench J 1985 The houses of Coleshill, *Recs Bucks* **25**, 61–109
- Cocroft WD 1985 Two post-medieval pottery kilns and associated products from Prosser's Yard, Brill, Buckinghamshire, *Recs Bucks* **27**, 72–94
- CVAHS 1984 *The People of Chesham. Their births, marriages and deaths 1637–1730. From the registers of St Mary's Church*. Chess Valley Archaeol Hist Soc (Chesham)
- Eland G (ed.) 1931 *Purefoy Letters 1735–1753, vols I & II*
- Elvey EM & GR (eds) 1978 *A catalogue of court rolls, rentals and charters mainly of thirteenth to sixteenth century date from the muniments at Hartwell House now the property of the Buckinghamshire Archaeological Society and preserved in its Muniment Room*. (Typescript in CBS: *nb*: these records are now stored with the CBS).
- Elvey GR (ed.) 1975 *Luffield Priory Charters, Part II*. Bucks Record Soc **18**
- Elvey EM (ed.) 1975 *The Courts of the Archdeaconry of Buckingham 1483–1523*. Bucks Record Soc **19**
- Farley ME & Hurman B 1978 Inscribed and dated pots of the eighteenth and nineteenth centuries from Brill, Buckinghamshire, *Recs Bucks* **20**, 627–629
- Farley ME 1979 Pottery and pottery kilns of the Post-Medieval period at Brill, Buckinghamshire, *Post-Medieval Archaeol* **13**, 127–52
- Farley ME 1982a Excavations at Low Farm, Fulmer, Buckinghamshire: 2 The Medieval Manor, *Recs Bucks* **24**, 46–72
- Farley ME 1982b A medieval pottery industry at Boarstall, Buckinghamshire?, *Recs Bucks* **24**, 107–117
- Farley ME & Leach H 1988 Medieval pottery production areas near Rush Green, Denham, Buckinghamshire, *Recs Bucks* **30**, 53–102
- Farley M & Lawson J 1990 A fifteenth century pottery and tile kiln at Leyhill, Latimer, Buckinghamshire, *Recs Bucks* **32**, 35–62
- Foard G 1991 The medieval pottery industry of Rockingham Forest, Northamptonshire, *Medieval Ceramics* **15**, 13–20
- Gaimster D 1994 The archaeology of post-medieval society, c.1450–1750: material culture studies in Britain since the war in B Vyner (ed.) *Building on the Past: papers celebrating 150 Years of the Royal Archaeological Institute*, 283–312
- Garrett-Pegge JW 1904 *A transcript of the first volume, 1538–1636, of the parish registers of Chesham in the county of Buckinghamshire*
- Green M, Hunt B & Tebbutt L 2000 *Penn and Tyler's Green*. Sutton (Stroud)
- Green M 2005 Medieval tile industry at Penn, *Recs Bucks* **45**, 115–60
- Green M 2013 Wycombe Heath and the Londoners Chase, *Recs Bucks* **53**, 151–161
- Greene J 1987 Brightening the long days: hospital tile pictures?, *J Tile Architectural Ceramics Soc*, 45–6
- le Hardy W & Reckit L (eds) 1936 *Calendar to the Sessions Records. County of Buckinghamshire, II*, 1694–1705
- le Hardy W (ed.) 1951 *Calendar to the Sessions Records. County of Buckinghamshire, IV*, 1712–1718 (bound typescript CBS)
- Hatton SI 1979 Akeley church to be made redundant, *Bucks & Berks Countryside* **19.142**, June 1979, 24–5
- Hay D & Hay J 1971 *Hilltop villages of the Chilterns*. Phillimore (London & Chichester)
- Herbert T 1985 More on Medmenham, *Glazed Expressions. J Tiles Architectural Ceramics Soc* **11**, 4
- Hohler C 1941 Medieval paving tiles in Buckinghamshire, *Recs Bucks* **14**, 1–49
- Hohler C 1942 Medieval paving tiles in Buckinghamshire (concluded), *Recs Bucks* **14**, 99–132
- Hoyle 1997 The forest under the Dynhams in J Broad & R Hoyle (eds) *Bernwood; the life and afterlife of a forest*, 90–107. Harris Paper Two. University of Lancashire
- Hunt J, Bettridge R & Toplis A (eds) 2001 *Index to the Probate Records of the Archdeaconry Court of Buckingham 1483–1660 and of the Buckinghamshire Peculiars 1420–1660*. Bucks Record Soc **32**
- Hunt J 2001 *A History of Amersham*. Phillimore (Chichester)
- Hunt J 2009 *A History of Coleshill*. RJL Smith & Assocs (Much Wenlock)

- Hurman B & Nenck B 2000 The Gerald Dunning Archive and a study of medieval roof furniture, *Medieval Ceramics* **24**, 63–72
- Hurman B 2004 A late medieval decorated tile, with other ceramic products from kiln areas at Cadmore End Common, Fingest, Buckinghamshire: a preliminary note, *Recs Bucks* **44**, 21–29
- Hurst D & Freestone IC 1996 Lead glazing techniques from a medieval kiln site at Hanley Swan, Warwickshire, *Medieval Ceramics* **20**, 13–17
- Hutchings N & Farley ME 1989 A fifteenth to sixteenth-century pottery industry at Tylers Green, Buckinghamshire, *Recs Bucks* **31**, 105–111
- Ivens RJ 1981 Medieval pottery kilns at Brill, Buckinghamshire: preliminary report on excavations in 1978, *Recs Bucks* **23**, 102–106
- Ivens RJ 1982 Medieval pottery from the 1978 excavations at Temple Farm, Brill, *Recs Bucks* **24**, 144–170
- Jefferys 1770 *Buckinghamshire in the 1760s and 1820s: the county maps of Jefferys and Bryant*. Reprinted Bucks Archaeol Soc 2000
- Jenkins GJ 1935 *A History of the Parish of Penn in the County of Buckinghamshire*. St Catherine Press (London)
- Jenkins JG (ed.) 1938 *The Cartulary of Missenden Abbey, Bucks. Part I*. Bucks Archaeol Soc Records Branch **2**
- Jenkins JG 1941 *A Calendar of Deeds and other Records preserved in the Muniment Room at the Museum, Aylesbury*. Bucks Archaeol Soc Records Branch **5**
- Jope EM 1945 Recent mediaeval finds in the Oxford area, *Oxoniensia* **10**, 96–99
- Jope EM 1950 Northamptonshire: a later medieval pottery kiln at Potterspurty, *The Archaeological Newsletter*, 10 March 1950, 156–157
- Jope EM 1953–4 Medieval pottery kilns at Brill, Buckinghamshire: preliminary report on excavations in 1953, *Recs Bucks* **16**, 39–42
- Jope EM & Ivens RJ 1981 Some early products of the Brill pottery, Buckinghamshire. *Recs Bucks* **23**, 32–38
- Jope EM & Ivens RJ 1995 A later medieval pottery kiln at Potterspurty, Northamptonshire, *Northants Archaeol* **26**, 141–148.
- Kellys (various dates). *Kelly's Post Office Directory* (various slight changes in title and coverage over the years).
- Kidd RA 1993 *Buckinghamshire Wills and Administrations in the Prerogative Court of Canterbury 1700–1800*. Bucks Family Hist. Soc.
- Latham RE 1965 *Revised Medieval Latin Word-List*
- Lipscomb G 1847 *History & Antiquities of the County of Buckingham, vols 1–4* (London)
- Le Patourel HEJ 1968 Documentary evidence and the medieval pottery industry, *Med Archaeol* **12**, 101–16
- Mawer A & Stenton FM 1969 *The Place Names of Buckinghamshire*. English Place-Name Soc **11**.
- McCarthy MR & Brooks CM 1988 *Medieval Pottery in Britain AD 900–1600*. Leicester Univ Press
- McGarva A 2000 *Country Pottery. The traditional earthenware of Britain*
- Mellor M 1994 A synthesis of Middle and Late Saxon and medieval and early post-medieval pottery in the Oxford region, *Oxoniensia* **59**, 16–217
- Mellor M 1997 *Pots and People that have shaped the Heritage of Medieval and Later England*. University of Oxford, Ashmolean Museum [booklet]
- Mellor M 2010 Pottery and potters, in K Tiller & G Darkes *An Historical Atlas of Oxfordshire*. Oxfordshire Record Soc **67**, 64–5
- Mephram L & Heaton MJ 1995 A medieval pottery kiln at Ashampstead, Berkshire, *Medieval Ceramics* **19**, 29–43
- Milbank D 2008 *An archaeological evaluation for the Diocese of Oxford at Village Farm, Main Road, Boarstall, Buckinghamshire SP 6254 1432*. Thames Valley Archaeol Services
- Miller F 1900 A sculptor-potter, Mr Conrad Dressler, *The Artist* (1900), 169–176
- Morley Davies A 1912 *Buckinghamshire*. Cambridge County Geographies. Cambridge University Press
- Morris J (ed.) 1978 *Domesday Book 13 Buckinghamshire*. Phillimore (Chichester)
- Murray J 2001 *Land to the rear of the Sun Hotel, Brill. An archaeological evaluation*. Hertfordshire Archaeol Trust Rep **867** [HER 1164701]
- Musty J 1974 Medieval pottery kilns, in VI Evison *et al. Medieval Pottery from Excavations*.
- Myres JL 1892 History and antiquities of Water Stratford, Bucks, *Recs Bucks* **7.2**, 117
- Myers R 1984 The Medmenham Pottery, *Glazed Expressions. J Tiles Architectural Ceramics Soc* **6**, 1–2

- Mynard DC 1970 Medieval pottery of Potterspury type, *Bull Northants Federation Archaeol Socs* **4**, 49–55
- Mynard DC 1984 A Medieval Pottery Industry at Olney Hyde, *Recs Bucks* **26**, 5685
- Mynard DC & Zeepvat RJ 1991 *Excavations at Great Linford 1974–80*. Bucks Archaeol Society Monog **3** (Aylesbury)
- Neal S c.2011 *Chalfont St Peter Manor Court Rolls, vols 1–3 (1308–1936)*. (Self-published: in CBS)
- Newell RW 1995 Some notes on splashed glazes, *Medieval Ceramics* **19**, 77–78
- Page M (ed.) 1996 *The Pipe Roll of the Bishopric of Winchester 1301–2*. Hants Record Soc Ser **14**
- Page M (ed.) 1999 *The Pipe Rolls of the Bishopric of Winchester 1409–10*. Hants Record Soc Ser **15**
- Parker J 1878 *The Early History and Antiquities of Wycombe in Buckinghamshire*. Butler & Son (High Wycombe)
- Pevsner N & Williamson E 1994 *Buckinghamshire. The Buildings of England*. Penguin Books
- Pike A 1995 *Gazetteer of Buckinghamshire Brick-yards*. Bucks County Museum [booklet]
- Plaisted AH 1925 *The Manor and Parish Records of Medmenham, Buckinghamshire*
- Prosser J 1999 Industry – bricks and pottery, in D Croydon (ed.) *Brillennium: 1000 years in the life of a Buckinghamshire village*. Hilltop Publishing (Brill)
- Prestwich J 1850 On the structure of the strata between the London Clay and the Chalk, *Quart J Geol Soc London* **6**, 252–281
- Priest Rev. St John 1813 General view of the agriculture of Buckinghamshire
- Reed M 1988 *Buckinghamshire Probate Inventories 1661–1714*. Bucks Record Soc **24**
- Reed M 1997 *Buckinghamshire Glebe Terriers 1578–1640*. Bucks Record Soc **30**
- Rice M (ed.) 1980 *A South Bucks Village. The History of Hedgerley*. Hedgerley Hist. Soc.
- Rice M (ed.) 2006 *A South Bucks Village. The History of Hedgerley*. Hedgerley Hist. Soc. (revised and expanded edition.)
- Rice P & Gowing C 1989 *British Studio Ceramic*
- Rotheroe J 1966 The potters of Bucks, *Bucks Life*, December 1966, 6–9
- Salter HE 1930 *The Boarstall Cartulary*. Oxford Hist. Soc. **98**
- Salter HE 1935 *Cartulary of Osney Abbey, V*. Oxford Hist Soc **98**
- Sheahan JJ 1862 *History and Topography of Buckinghamshire*
- Sherlock R & Noble AH 1922 *Memoirs of the Geological Survey; Explanation of Sheet 255. The Geology around Beaconsfield*
- Slowikowski AM 2011 *Genius in a cracked pot*. Medieval Pottery Res Group Occ Paper **4**
- Stebbing N, Rhodes J & Mellor M 1980 *The Clay Industries of Oxfordshire: Oxfordshire potters*. Oxfordshire Mus Service Pub **13** [pamphlet]
- Sturdy D & Case H 1961/2 Notes and News, *Oxoniensia* **26/27**, 336
- Sutherland DS 2003 *Northamptonshire Stone*. Dovecote Press (Dorset)
- Tankard D 2008 Graffham and Woolavington. Potters, tile-makers and brickmakers, c.1500–1740, *Sussex Arch Coll* **146**, 175–8
- Trusted M 1996 Acquisitions in Focus. Dressler's terracotta bust of his wife at the V&A, *Apollo*, January 1996
- Turner RM Rev. c.1910 *Notes from the Annals of Akeley* (reprinted from the Buckingham Advertiser and North Bucks Free Press: copy in CBS)
- Vaisey DG & Celoria F 1974 Inventory of George Ecton, 'Potter' of Abingdon, Berks, 1696. *J Ceramic Hist* **7**. George Street Press (Stafford)
- Vere Woodman A 1960 The accounts of the churchwardens of Wing. *Recs Bucks* **16**, 307–329
- Walker R 1986 Medmenham Pottery and Conrad Dressler', *Glazed Expressions: J Tiles Architectural Ceramics Soc* **12**, 8–10
- Webb C 1992 *National Index of Parish Registers. Vol. 9, Part 3, Buckinghamshire*. Soc Genealogists (London)
- Wells M 2002 The Old Stores, Leyhill: pottery collected from the front garden, *Chess Valley Archaeol Hist Soc J*, 10–11
- Williams G 2010 *Excavation of a late medieval workshop and pits adjacent to Prosser's Yard, 7 & 9 Temple St, Brill, Buckinghamshire* NGR SP 65465 14030. John Moore Heritage Services report (HER 9887)
- VCH 1908 *A History of the County of Buckinghamshire II*. Victoria County History
- VCH 1927 *A History of the County of Buckinghamshire IV*. Victoria County History
- Yeates S 2012 *Historic building assessment and archaeological watching brief on the Red Lion, Church Street, Brill*. John Moore Heritage Services report (copy with HER)
- Yeoman P 1988 Excavation of an early post-me-

dieval Kiln at Temple Street, Brill 1983, *Recs Bucks* 30, 123–155  
 Youngs FA 1979 *Guide to the Local Administrative Units of England. Vol. 1: Southern England.* Royal Hist Soc (London)  
 Zeevat B (ed.) 2009 Rose Cottage, Tylers Green: excavation of a 15<sup>th</sup> to 17<sup>th</sup> century tiler, *Recs Bucks* 49, 189–218

## APPENDIX

Where a considerable number of potters are recorded in a parish, e.g. in a census or parish register, they have been listed below rather than in the main text.

**Amersham, Coleshill and Penn Street***1841 Census:*

## Potters:

John Rogers (40) pot maker, Amersham  
 Richard Rogers (45) potmaker, Amersham  
 James Slade (67) potter, Coleshill Green [a substantial landowner with a kiln on the tithe map]  
 Joseph Slade (38) potter, Coleshill Green  
 Job Slade (30) potter, Coleshill Green  
 Thomas Carter, potter, Coleshill Green  
 Joseph Saunders (40) potter, Coleshill Green  
 Charles Shep (60) potman, Coleshill [probably Shepherdley]  
 William Rogers (22) pot man, Winchmore Hill  
 Joseph Drake (50) pot man, Winchmore Hill  
 Henry Sheperdley (30) pot man (it may be noted that the name ‘Shipperley’ occurs as early as 1660 at Brill), Winchmore Hill  
 James Griffin (60) potter, Winchmore Hill  
 Henry Butler (65) potter, Winchmore Hill  
 George Gurney (18) potter, labourer, Winchmore Hill  
 George Carter (37) potter, Penn  
 Ephraim Bovingdon (25) potter, Penn Street  
 William Shepherdley (35) potter, Penn Street  
 William Pratley (74) pot maker, Penn Street (NB two Pratleys were operating at Buckland at the same date. This William might be the same man recorded at Penn Street in 1791)

## Hawkers:

James Carter, pot hawker (a James Carter is named as a potter in 1839), Winchmore Hill  
 John Clark (44) hawker, Coleshill  
 Thomas West (50) hawker, Winchmore Hill  
 Joseph Slade (55) hawker, Winchmore Hill  
 Thomas Slade (78) pot hawker, Winchmore Hill  
 William Woodbridge (25) hawker, Coleshill  
 Stephen Miles (30) hawker, Penn Street

John Bovingdon (55) hawker, Penn Street  
 Richard Bovingdon (54) hawker, Penn Street  
 William Shepherdley (25) hawker, Coleshill  
 John Wright (60) hawker, Coleshill

*1851 Census:*

## Potters:

Sarah Slade (76), pot manufacturer, Coleshill Green. b. Coleshill (and five labourers). [She was the wife of James Slade. Her son Job, below, was probably the principal potter in the business]  
 Job Slade (41) potter, Coleshill Green. b. Coleshill  
 Allen Sears (22) potmaker, Coleshill Green. b. Coleshill  
 Thomas Sears (17) potter, Coleshill Green. b. Coleshill  
 John Porter (46) potter, Coleshill Green, b. Coleshill  
 Thomas Carter (40) potter, Coleshill Green, b. Coleshill  
 William Shepherdley (44) potter’s labourer, Samsons Lane, Coleshill  
 Ephraim Carter (32) labourer in pottery, b. Coleshill, Winchmore Hill (but recorded under Penn Street)  
 Richard Rogers (56) potter, Winchmore Hill, b. Penn  
 Ephraim Bovingdon (35) potter, Penn Street.  
 James Rogers (16) potter, Winchmore Hill, b. Amersham  
 Emanuel Pratley. (50) potter, Winchmore Hill, b. Wheatley (Oxon). He must have moved here from Buckland with his sons, born in Buckland, who are also listed here:  
 Jonathon Pratley (30) potter’s labourer, Winchmore Hill, b. Buckland  
 Charles Pratley (18) potter’s labourer, Winchmore Hill, b. Buckland  
 Joseph Drake (63) potter, Winchmore Hill, b. ‘Yeateley’, Hants. (Yateley is about five miles from Farnborough where there was a medieval and post-medieval pottery industry)  
 John Slade (45) potter, Winchmore Hill, b. Coleshill  
 George Wright (23) potter’s labourer, Winchmore Hill, b. Coleshill

## Hawkers:

Thomas Slade (70) pot hawker, Winchmore Hill  
 William Slade (59) hawker earthenware, Coleshill Green, b. Coleshill  
 James Carter (32) pot hawker, Winchmore Hill, b. Coleshill  
 David Pearce (20) earthenware dealer, Woodside Lane  
 George Bovingdon (60) hawker of pots, Penn Street  
 Richard Bovingdon (65) pot hawker, Penn Street

*1861 Census:*

## Potters:

Job Slade (1) potter (51) Coleshill Green (appears as an earthenware manufacturer at Coleshill in *Kellys* 1864)

Joseph Slade (1) potter (12) son of above, Coleshill Green (son)  
 Joseph Slade (2) potter (53), Coleshill Green.  
 James Slade potter (16) son of above, Coleshill Green (son)  
 William Slade, potter (22), b. Coleshill, lodging Tollgate House, Whieldon Lane  
 Thomas Sears (27) potter maker, Coleshill Green, born Herts. Coleshill  
 Joseph Drake (74), potter maker, Coleshill (widower)  
 John Toovey (31) pot manufacturer with eight men and four boys, Winchmore Hill (beerhouse)  
 Allen Readings (23?) potter, Winchmore Hill  
 Henry Shepherdley potter, (49) Winchmore Hill  
 William Shepherdley potter, (50) Winchmore Hill  
 John Slade potter (52), Winchmore Hill  
 George Slade (1) potter, (16) Winchmore Hill (son)  
 Job Slade (1) potter, (14) Winchmore Hill (son)  
 George Slade (2) potter (22), Winchmore Hill.  
 William Shrimpton (73) potter, Amersham Union Workhouse

## Hawkers:

John Clarke (62), Coleshill Green  
 Daniel Lawrence (43), Coleshill Lane  
 Charles Morecroft (54), Coleshill Green  
 John Sears (63), Coleshill Green  
 John Porter (56), Coleshill Green  
 William Sheperdley (46), Coleshill Green  
 George Slade (46), Winchmore Hill  
 James Bowler (64), Woodrow  
 Henry Rogers (25), Winchmore Hill  
 Henry Wright (39), Winchmore Hill  
 George Bovingdon (61?), Penn Street  
 Richard Bovingdon (65), Penn Street  
 Ephraim Bovingdon (45), Penn House, Penn Street  
 Stephen Miles (50), Penn Street  
 David Pearce (31), 'Amersham Common' (This location is a considerable distance from the Winchmore Hill complex)

## 1871 Census:

## Potters:

William Sheperdley (no. 1) (64?), widower, pot maker, b. Coleshill  
 William Sheperdley (no. 2) (52), potter, Coleshill  
 Job Slade (60), potter's labourer, Coleshill Lane  
 George Wright (43), potter's labourer, Coleshill  
 Job Slade (25) potter labourer, Coleshill Lane  
 Joseph Slade, potter (?60), Amersham Workhouse  
 Allen Reading (1) (42) potter and brewhouse keeper, Potter's Arms. b. Oxfordshire  
 Allen Reading (2) (15) son, potter (born Nettlebed, an Oxfordshire potting area)  
 Thomas Sears (37), potter, Straw Shed Cottage,

Winchmore Hill in the parish of Penn  
 Daniel Axten (22) potter's labourer, Winchmore Hill  
 Edward Bovingdon (50), kiln labourer, Cottage, Penn Street

## Hawkers:

David Pearce (40) pot hawker, Woodside Lane, Amersham Common  
 George Pearce, (25) ditto  
 William Pearce, (18) ditto  
 John Slade pot hawker, (63) Winchmore Hill  
 Edward Slade hawker, (39) Coleshill  
 Henry Wright (44) pot hawker, Winchmore Hill  
 Henry Wright (13) (son) labourer in a pottery  
 John Toovey hawker, Cottage, Winchmore Hill  
 David Sheperdley (81), late pot hawker, b. Winchmore Hill, Coleshill  
 William Sheperdley (no. 3) (53), pot hawker, Coleshill, b. Winchmore Hill  
 Ephraim Bovingdon (55) licenced hawker, Penn Street

## 1881 Census:

## Potters:

John Saunders (37) publican and earthenware potter, tenant of the *The Potters Arms*, Winchmore Hill who employed one labourer and three boys. [This must be the same John Saunders who was previously potting at Akeley]  
 Calib Saunders (15) earthenware potmaker and John Saunders (13) were his sons  
 Thomas Sears (47) potter (b. Coleshill), Winchmore Hill, Penn parish, Penn Street.  
 William Slade (40), potter, Penn, Penn Street [may have been working at Penn Street but more probably Winchmore Hill]  
 John Slade (72) potter, Amersham  
 Joseph Slade (72) potter 'Amersham' in workhouse

## Hawkers:

Henry Wright (59) pot hawker, Winchmore Hill  
 George Rogers (27) pot hawker, Winchmore Hill  
 George Slade (29) (b. Coleshill) agent for pottery  
 Henry Miles (46) pot hawker, Holmer Green  
 Henry Miles (16) pot hawker's assistant. Holmer Green [With this address the two Henrys may not have been attached to any particular pottery although Winchmore Hill would have been the nearest]  
 Ephraim Bovingdon (65) licenced hawker, Penn Street

## 1891 Census:

## Potters:

Joseph Hobbs (50), publican and potter, Coleshill (born Nettlebed, Oxon)  
 James E Hobbs (25), potter, Coleshill. [The Winchmore Hill Pottery pottery was to become his business: see



advertisement referred to above]  
 Gilbert Hobbs (21), potter, Coleshill  
 William J Balaam (30), potter, Coleshill  
 Thomas Sears (57), potter, Penn Street, b. Coleshill  
 William Fabry (57), potter, Coleshill  
 Benjamin Shrimpton (14) flower pot maker, Penn Street,  
 b. Penn Street  
 Joseph Newell (25) carter at pot works, Horsemoor  
 Lane, Penn  
 Joseph Darvill (64), retired potter, Amersham  
 William Shepherdly (77), retired pot and pan hawker,  
 Coleshill  
 Ephraim Bovington (75) dealer in pots. Penn Street, b.  
 Penn Street

*1901 Census:*

Thomas Sears (66) potter, earthworker, Penn  
 Joseph Slade (83) Amersham workhouse

*1911 Census:*

Thomas Sears (76) potter, employed Penn. There are  
 no other potters in this census so he is probably the  
 potter photographed at 'Winchmore Hill' at about  
 this time (Fig. 9). His son Thomas was born at  
 Winchmore Hill].

**Chalfont St Peter: 'Beaconsfield Pottery'**

For potters at the 'Chalfont St Peter' pottery see main  
 gazetteer

*1841 Census:*

James Halsey (29) potter, Wycombe Street, born Essex.  
 'Wycombe Street' has not been identified but it seems  
 likely that it was in Beaconsfield so he may have  
 worked at the Beaconsfield Pottery. It appears that by  
 1861 he may have moved to the 'Chalfont Pottery'.

*1851 Census 'Beaconsfield':*

## Potters:

1851 John Swallow potter, master (49) eleven men and  
 one boy, Chalfont Pottery [NB this is unlikely  
 to have been the pottery later called 'Chalfont  
 Pottery': see discussion]  
 1851 Robert Swallow potter (25), Twinning Road (for  
 his birth see above)  
 1851 Thomas Swallow potter, (26) Beaconsfield, born  
 Essex  
 1851 James Swallow potter (16), Beaconsfield born  
 there  
 1851 James Halsey potter (39), potter, Wycombe Road,  
 b. Ilford  
 1851 John Andrews potter's labourer (45), 27, London

Street [could be present London Road, Hunt &  
 Thorpe 2009, x, note a London End]. b. Hanley,  
 Staffs [this was in 'The Potteries'].

## Hawkers etc:

1851 William Bennett (25), potter's carter, Beacons-  
 field, 'Chalfont Pottery'  
 1851 James Ward (42) china dealer, Aylesbury End  
 1861 *Census:*

The enumerator area covered an area including 'Stamp-  
 wells Farm and Pottery.' Stampwell Farm lies a short  
 distance east of the Beaconsfield Pottery and Pot Kiln  
 Lane so the following would have worked there:

1861 Robert Swallow (34) pot master, employing ten  
 men and one boy, Pottery, Stampwell Farm.  
 1861 William Swallow potter (13) (son of above)  
 1861 John Seymour (57), potter's labourer, Stampwells  
 Pottery.  
 1861 Levi Lake, potter (22) 4, Twitchells, born Beacons-  
 field [Chalfont St Giles census area but place of  
 birth may indicate that this was the pottery he  
 worked at. In 1871 he worked in Hatfield as a  
 potter].  
 1861 John T Swallow (36), potter Seer Green.

*Kellys* 1869 records Robert Swallow as 'potter, Pottery'  
 with no further information (under 'Beaconsfield' a  
 John Swallow, brick and drain pipe maker, Pitlands  
 Wood, is noted).

*1871 Census:*

1871 Robert Swallow (44) potter master employing  
 three boys and seven men, The Pottery, Stampwell  
 1871 William Swallow potter (23), Stampwell Farm  
 1871 John Seymour (67) [potter's] labourer

*1881 Census:*

Robert Swallow (54) potter, six men and one boy,  
 Swallow Pottery [n.b.]  
 Mathew Swallow (21) potter [son of above] Swallow  
 Pottery  
 William Swallow (33) potter [no address]  
 Thomas Grimmett (12) potter's boy, Beaconsfield  
 John Swallow (32) red potter (earthenware) born  
 Beaconsfield

*1891 Census:*

It is known that Martha Saunders had taken over the  
 Beaconsfield Pottery by this date, so the following  
 Swallows (although none exactly match the previous  
 1881 returns) were probably based here:

Martha Saunders (widow) (43), manufacturer of pottery ware [born Seer Green]  
 Frederick Saunders (19) potter [born Burnham]  
 Albert Saunders (15) potter's labourer [born Burnham]  
 William Robert Swallow (20) potter [born CSP]  
 Henry Swallow (19) potter [born CSP]  
 Arthur Joseph Swallow (18) potter's labourer [born CSP]

*1901 Census:*

Martha Saunders (53), brick tileworks, employer. Potteries  
 Fred Saunders (29), flower pot maker, worker, Potteries  
 Albert Saunders (24) flower pot maker, worker, Potteries  
 Henry Swallow (29) flower pot maker, worker, Potteries

**Chesham**

The names of potters recorded below occur in the Chesham parish registers unless otherwise noted. Some of the same individuals occur on more than one occasion. The registers for 1538–1636 are transcribed in Garrett-Pegge (1904); and for 1637–1730 in CVAHS (1984). Where present the potter's specific area of domicile is included. Unless otherwise stated, all the records are of burials or probate.

1594. Overstreet, Botley, Chesham, potter (Hunt *et al* 2001, 287)  
 1598. Overstreete, old John, Leyhill  
 1603. Overstreete, John of Botley, marriage to Emme of Robert Overstreet widow  
 1603 Overstreet, Robert  
 1603 Owen, Daniell, son of John and Alice  
 1607. Owen, John, baptism of daughter. 1607. This is probably the same John Owen, potter: whose will

was proved in 1639 (CBS DAWE 32 114)  
 1607. Overstreete, Henry  
 1607. Overstreet, William, his widow Emme buried. The will of another William Overstrete of Botley was proved in 1624 (CBS DAWE 28A 286)  
 1616. Overstreete, John; his wife Emme buried  
 1616. Owen, John, a child of his buried  
 1617. Overstreete, John.  
 1624. Overstrete, William, Botley, Chesham, potter (Hunt *et al* 2001, 287)  
 1639. John, Chesham, potter (Hunt *et al* 2001, 288)  
 1662. Ingram, William, a child of his buried  
 1663. Ingram, William  
 1664. Fryar, Richard of Lehill. 1664 (parish registers) P122. His will 'Richard Frier, potter. Chesham', proved 1664 (CBS DAWE /43/35)  
 1664. Harding, John  
 1679. Heward, John  
 1681. Alce, James  
 1685. Ware, Edward  
 1686. Ware, Edward, a child of his buried  
 1687. Bampton, Abraham  
 1699. Ware, Edward 'of the towne'  
 1699. Fryer, Richard, burial of Martha, his widow 'of the Waterside'  
 1702. Bampton, Timothy of Ashleygreene, a child of his buried  
 1702. Bampton, Daniel a son of his buried  
 1709. Fryar, Richard Fryar  
 1713. Bampton, Daniel and Susannah, a child of theirs buried  
 1715. Bampton, Timothy potter (collector) [presumably pot seller]  
 1720. Spide, John (junior), potter, Chesham. Will, 1720 (DAWE 57/109)  
 1728. Bampton, Daniel