

THE CHURCH PLATE OF BUCKINGHAMSHIRE.

RURAL DEANERY OF MURSLEY.

THE notes which follow are the first instalment of a survey of the Church Plate of the Archdeaconry of Buckingham, which was undertaken for the Archæological and Architectural Society in 1891. The long delay in publication is due partly to the compiler's repeated absence from England, partly to the fact that of the schedules issued to every parish less than half have been returned at all, and of those which have been filled in, all needed a detailed revision; while in many cases the work has practically had to be done over again. The fullest acknowledgment, however, is due to all those who have attempted what must have been a very unfamiliar task, and in particular for the elaborate drawings which have accompanied many of the returns.

The compiler has in every case examined the vessels, and compared his own observations with the returns. The only point on which there is likely to be any error is in the weights. Troy weights are not accessible everywhere, and in those cases where the symbol *w.* is enclosed in square brackets, it is to be understood that the weight was ascertained in *oz. avoirdupois*, and reduced approximately to *oz. troy*. In a few cases, however, it has been possible to ascertain the troy weight of the vessels directly.

The numbers appended to the several parishes are those under which they stand in the Diocesan Calendar.

The chronological summary at the end includes only the silver vessels; the pewter and plated vessels are not sufficiently well fashioned or dated to justify tabulation.

ASTON ABBOTTS.

St. James.

567.

1. CUP WITH COVER.—Silver, parcel-gilt. H. 7 in., diam. base $3\frac{1}{2}$ in., bowl $3\frac{3}{4}$ in., depth 4 in., [w.] 10 ozs. $4\frac{1}{2}$ dwts. Hallmarks: London, 1562. Maker's mark: , within a circle of rays, alternately straight and wavy: Cripps "Old English Plate," 4th edn., p. 389 (1562).

- This beautiful cup is of the "prescribed form," with deep body and short foot. It has two bands of the usual ornament on the bowl (Pl. ii. 3); all the ornaments are parcel-gilt.
2. **PATEN**.—Plated. H. $1\frac{1}{2}$ in., diam. 9 in. Sacred monogram, and the inscription: "*Aston Abbotts, 1861.*" Bought of Mr. Field, Aylesbury, 1861.
 3. **FLAGON**.—Plated. H. $9\frac{1}{2}$ in., diam. top $3\frac{1}{2}$ in., base $4\frac{3}{4}$ in. Monogram and inscription as on the Paten, with which it was bought.
 4. **ALMSDISH**.—Brass, engraved. Bought 1890.
 - 5-7. **CROSS AND CANDLESTICKS**.—Brass. Presented 1888. **FLOWER-VASES**.—Brass. Presented 1895.

CUBLINGTON.

St. Nicholas.

568.

1. **CUP WITH COVER-PATEN**.—Silver. H. $5\frac{1}{2}$ in., diam. base $3\frac{1}{2}$ in., bowl $3\frac{1}{2}$ in., depth 4 in., w. 8 ozs. 4 dwts. Hallmarks: London, 1692. Maker's mark: S H, linked in plain shield (*cf.* Cripps O.E.P.⁴, p. 366 (1684); but the latter is in a *round* stamp, with a border of dots). The cup is quite plain, and of similar type to that at Tattenhoe, *q.v.*
2. **COVER-PATEN OF No. 1**.—Silver. H. $\frac{3}{4}$ in., diam. $3\frac{3}{4}$ in., foot 2 in., w. 2 ozs. 16 dwts. 6 grs. Hallmarks and maker's mark as on the cup, but much defaced. Inscription: "*Anno Dom̄. 1692.*"
3. **FLAGON**.—Pewter. H. $7\frac{1}{2}$ in., diam. 3 in., base $4\frac{1}{2}$ in. No marks. A short, wide variety of the cylindrical type, with spout.
4. **ALMSDISH**.—Wooden; modern.

DRAYTON PARSLOW.

Holy Trinity.

569.

1. **CUP WITH COVER**.—Silver. H. 7 in., diam. bowl $3\frac{1}{2}$ in., base $3\frac{1}{4}$ in., depth of bowl 4 in., [w.] 7 ozs. 1 dwt. Hallmarks: London, 1569. Maker's mark: A shaped stamp, like a "Britannia" lion's head.

COVER WITH FOOT-HANDLE.—H. $1\frac{1}{4}$ in., diam. $3\frac{3}{8}$, [w.] 2 oz. Same Hallmarks and maker's mark. This is a large specimen of the "prescribed form." The band of ornament runs close under the rim, and is shown in Pl. ii. 4. About one-third down the bowl is a prominent moulding, from which depend foliated ornaments of the usual type. (Pl. ii. 5.)

2. CUP (missing).—The following entry occurs in the Parish Register:—

"4th July, 1756. Recd. then of the Rev. Mr. Lord, Rector of this Parish, one Cup with a Cover to it for the Communion Service. Wt. 4 oz. 5 dwts., with this inscription on it: '*In Usam Infirmorum.*'"

THOS. WELLS, } Churchwardens.
NEWMAN BATES, }

This Cup has now long disappeared. The existing "Cup with a Cover" is heavier, and has no inscription. The provision of a cup for private administration to the sick is unusual.

3. PATEN.—Plated. Diam. 9 in.; modern, quite plain.
4. PATEN.—Plated. Diam. $5\frac{1}{4}$ in.; modern. Inscription on the rim: "✠ *Do this in remembrance of Jhr.*"
5. FLAGON.—Plated. H. $8\frac{3}{4}$ in.; modern. Of the usual type; quite plain.
6. FLAGON.—Pewter. H. 9 in., diam. $4\frac{1}{2}$ in. This is of unusual form. It stands on a high foot; and the body is short and cylindrical above, with a swelling below the bottom of the spout, which is covered above. Eighteenth century.
7. ff. ALMSDISH, cross, candlesticks, flower vases, desk, etc. Brass; modern.

The following extract from a Terrier of 1855, copied with many other chronicles into the Parish Register, may be quoted, though it is inaccurate if it refers to the existing vessels, and though the weights are left blank.

Within and belonging to which [the Church] are 1 Communion table, with a covering for the same of Blue Velvet with one Cushion. Item: one linen cloth for the Communion Table, with one Napkin, one silver Flagon and chalice, weighing —, one silver paten.
. . . [Then follow minor Church fittings.]

DUNTON.

St. Martin.

570.

1. CUP.—Silver, bowl gilt outside. H. 6 in., diam. $3\frac{1}{8}$ in., [w.] 10 ozs. 1 dwt. Hallmarks: London, 1809. Maker's mark:

RE
EB

 Inscription on bowl: "*H. S. M.*

<i>W.D.</i>	}
<i>S.B.</i>	

Churchwardens, 1811." The bowl is nearly cylindrical; the slight lip has a marginal beading; the stem is short and thick, without central swelling; the foot has the characteristic triple beading of the period.
2. PATEN.—Silver. H. 1 in., diam. $6\frac{1}{2}$ in., [w.] 9 ozs. $2\frac{1}{2}$ dwts. Hallmarks: London, 1811. Maker's mark: W.B. in oval. Inscription in script (*a*) in the centre, "*Wm. Duncombe, Saml. Blick, Church-Wardens;*" (*b*) round this, "*A Gift from the Rev. H. S. Milner, D.C.L., to the Parish of Dunton, 1811.*" This is a salver on three feet which have convergent flutings and end in a small ball, of the same pattern as the plated almsdish (1797) at Little Horwood.
3. FLAGON.—Silver. H. $7\frac{3}{4}$ in., diam. base $3\frac{1}{2}$ in., greatest $3\frac{3}{4}$ in. [w.] 13 ozs. 14 dwts. Plain. Hallmarks and maker's mark as on No. 2. Inscription round the body: "*H. S. M.*

<i>W.D.</i>	}
<i>S.B.</i>	

Churchwardens, 1811," as on No. 1. This vessel is not a Flagon, but a Jug or Ewer without cover, of about one pint capacity, with quadruple beadings round the foot, the base of the body, and the greatest diameter.
4. ALMSDISH.—Silver. H. $\frac{3}{4}$ in., diam. $9\frac{1}{8}$ in., [w.] 15 ozs. 10 dwts. Hallmarks and maker's mark and inscription as on No. 2. Plain.

Rev. Henry Stephen Milner, D.C.L., was rector of Dunton from 1788 (Feb. 15) to 1798 (July 7), when he resigned: he was reappointed in 1801 (June 27), and held the living till 1811.

HARDWICKE.

St. Mary.

571.

1. CUP.—Silver, bowl gilt inside. H. 7 in., diam. $3\frac{1}{4}$ in., bowl 3 in., depth $3\frac{1}{4}$ in., [w.] 7 ozs. 6 dwts. Hallmarks: London, 1872. Maker's

mark:  under the foot the figures 949.

Quite plain; small bowl; tall stem with central swelling.

2. PATEN, with foot.—Silver. H. $2\frac{1}{2}$ in., diam. $8\frac{2}{5}$ in., foot $3\frac{1}{2}$ in., [w.] 11 ozs. 17 dwts. Hallmarks: London (Britannia), 1718. Maker's mark: I. S., uncertain object below, in shaped stamp. Inscription on under-surface: "*For the Service of the Altar in the Church of Hardwick. John White, LL.B., Rector, 1813.*" On upper-surface, Sacred Monogram, cross fitchée, and nails, within star of 27 rays.
3. PATEN.—Silver. H. $1\frac{3}{5}$ in., diam. 6 in., [w.] 3 ozs. 13 dwts. Hallmarks: London, 1871. Maker's mark:  Sale-stamp: F. SMITH & Co., LONDON.
4. FLAGON.—Silver. H. 10 in., diam. top $1\frac{3}{4}$ in., base $3\frac{1}{5}$ in., greatest $3\frac{2}{5}$ in., [w.] 13 ozs. 14 dwts. Hallmarks: London, 1870. Maker's mark (same as on the Cup); cruet-shaped, with pear-shaped body, tapering upwards to a narrow neck with a spout and hinged cover surmounted by a Maltese cross.
5. FLAGON.—Plated. H. $7\frac{3}{4}$ in., diam. top $3\frac{1}{5}$ in., base $4\frac{3}{4}$ in., w. 24 oz. av. A tankard, short and wide. No marks; probably early nineteenth century.
6. ALMSDISH.—Brass. Given by Miss Charlotte M. Yonge, Otterbourne, Hants.
7. CROSS.—Brass. Given by C. M. Shipley, Esq., Twyford, Hants.
8. PAIR OF BRASS CANDLESTICKS.—(Jones and Willis.) Given by Mrs. Richards, Theale, Berks.

HOGGESTON.

Holy Cross.

572.

1. CUP WITH COVER.—H. $6\frac{1}{2}$ in., diam. base $3\frac{1}{2}$ in., bowl $3\frac{3}{8}$ in. depth, $3\frac{1}{2}$ in. av., [w.] 10 oz. 19 dwts. Hallmarks: London, 1569. Maker's mark (almost illegible), P. S. monogram (*cf.* Cripps O. E. P.⁴, p. 345 (1562)).
A small but fine specimen of the "prescribed form;" the band of ornament is narrow, with simple interlacement and foliage appendages above and below (Pl. ii. 6). The base has been roughly mended.
2. COVER-PATEN ON FOOT.—Silver? H. $1\frac{1}{2}$ in., diam. $7\frac{5}{8}$ in., foot $3\frac{1}{2}$ in., [w.] 9 oz. 2 dwts. No Hallmarks. Maker's mark, half effaced R . *Vide* List of Marks. Sacred Monogram, cross fitchée and star, within a circle of rays, and the inscription: "*Deo et ecclesiæ Hogiston, C. G. R. D. D. D.*" Rev. Charles Gataker, son of Rev. Thos. Gataker (*vide* below), was M.A. of Clare Hall, Cambridge (1674), and succeeded his father as Rector of Hoggeston, 1680. He died 10 Nov., 1701.
3. FLAGON.—Silver. H. $7\frac{1}{2}$ in., diam. lip 4 in., base $5\frac{1}{2}$ in., [w.] abt. 27 oz. Hallmarks: London, 1683. Maker's marks: (1) T. C.; a fish above; a fleur-de-lys below; in shaped shield (Cripps O. E. P.⁴, p. 364 (1677)); common on Kentish Church Plate of this period. (2) under the foot L. 3) on the handle, a trefoil.* This is a plain quart tankard with lid. Inscription: "*Deo et ecclesiæ Hoges toniensi sacrum ex dono T. G. Rects., 1683.*" Rev. Thomas Gataker was Rector of Hoggeston, 1646-1689, and is there buried.
4. ALMSDISH.—Brass. Bought in 1882.
5. PAIR OF GLASS CRUETS, with electroplate mounts; modern.

* The present Rector, Rev. C. H. Tomlinson, reads the *maker's mark* repeated on the lid and handle.

GREAT HORWOOD.

St. James.

573.

1. CHALICE.—Silver, bowl gilt inside. H. 8 in., diam. base $4\frac{3}{4}$ -5 in., bowl 4 in., depth 3 in. [w.] 11 oz. 18 dwts. Hallmarks: London, 1873. Maker's mark: $\frac{H E}{W}$ in trefoil stamp. Hexagonal stem, with Sacred Monogram on one face of the base, and cross on opposite face; the knob of the stem is also ornamented with two crosses on each alternate face.

This replaces an older cup of silver, which is recorded in an inventory of the plate, undated, but made, as the writing and the watermark show, by the Rev. Richard Tomkyns (Rector, 1816, 6 Oct., to 1839), not earlier than 1819.

The following entries occur in an account book of the late Rector, Rev. S. T. Adams, as treasurer of the Great Horwood Church Restoration Committee:—

1874. Oct. 9.—For 2 metal Ch. Plates,	
C.R.	£1 0 0
1876. Feb. 28.—For Chalice and Cover,	
10oz. 13dwts., at 4s. 7d., by Mr. H. Young	2 8 8
1880. Feb. 2.—Pewter Flagon, 2s.,	
Cushions, 5s., H.Y.	0 7 0

- 2-3.—PAIR OF PATENS ON FEET.—Silver. H. 1 in., diam. $7\frac{1}{4}$ in., foot $3\frac{1}{4}$ in., [w.] 8 oz. 2 dwts. Hallmarks: London (Britannia), 1697. Maker's mark: S I, in angular shield; a fish (?) below. (? Francis Singleton). Cripps O. E. P.⁴, p. 370 (1699); but the latter has a shaped shield. Sacred Monogram in circle of alternate rays. Inscription on rim: "The Gift of Charles Holloway, of London, Goldsmith, a Native of this Parish [*], for y^e Sole & only use of y^e Church of Great Horwood, in the County of Bucks." At *, in an oval between two cornucopiæ, are engraved the arms, *arg. a fess, between three crescents, sable; a canton ermine* (). The same arms appear at Winchester College in the cornice of "School." Charles Holloway, son of Rev. Wm. Holloway, Rector (1702, 3 July, to 1718), buried 11 Aug., 1718, at Horwood, was baptised 18 July, 1706. He was Scholar of Winchester College (Founder's Kin), 1722-1724.

4. FLAGON.—Silver. H. $11\frac{1}{8}$ in., diam. lip $3\frac{3}{8}$ in., base $6\frac{1}{4}$ in. [w.] 35 oz. 16 dwts. Hallmarks: London, 1755. Maker's mark: *T. W.*, in shaped stamp (= Thomas Whipham, entered 1739. Cripps O. E. P.⁴, p. 401 (1756), but the shield differs slightly). Inscription: "The Gift of Geo. Verney, of London, to the Parish of Great Horwood, in the County of Bucks, of Which he was a Native. For the Sole use of the Communion Table of the said Church, 1755." One George Verney, son of Robert and Elizabeth Verney, was baptised at Horwood on 7th July, 1723; another, the son of George and Hester Verney, on 29th August, 1708.
5. ALMSDISH.—Brass; modern. Sacred Monogram in six-cusped circle. Inscription on rim, "To do good and to distribute forget not." Candlesticks, flower vases, desk, &c.; brass; modern.

LITTLE HORWOOD.

St. Nicholas.

574.

1. CUP WITH COVER.—Silver. H. $5\frac{1}{2}$ in., diam. base $3\frac{1}{4}$ in., bowl $3\frac{1}{8}$ in., depth $3\frac{1}{2}$ in., w. 7 oz. 5 dwts. Hallmarks: London, 1562. Maker's mark: ? animal's head (much rubbed). The cup bears no inscription, and the cover, which is dated 1570, does not belong to it. It has a thick hollow stem with a simple curve, and no swelling or ridge like most of the cups of this series. It has the usual band of ornament near the rim, with simple interlacement and small pendants; the same band, but without pendants, is repeated on the foot. (Pl. ii. 1.)
2. COVER-PATEN.—Silver. H. $1\frac{1}{8}$ in., diam. $3\frac{1}{4}$ in., foot 1 in., w. 1 oz. 16 dwts. Hallmarks: London, 1569. Maker's mark: *I P* in shaped shield (Cripps O.E.P.⁴, p. 345 (1566). Date 1570 engraved on the handle-foot. This cover does not belong to the cup; it does not fit it well, and has a different band of ornament; and it is unlikely that a "restored" cover would be engraved with a date which was not that of the original. It is probable, therefore, that the cover, at all events, came from elsewhere.

- 3-4.—PAIR OF CUPS.—Plated copper. H. $7\frac{5}{8}$ in., diam. base $3\frac{1}{2}$ in., bowl $3\frac{1}{2}$ in., depth $3\frac{5}{8}$ in. No marks. Inscription as follows, on an oval plate affixed to the bowl: “Hic Calix Datus est in Ufum Ecclesie Horwood Parvæ a Stephano Langton, A.M., Vicario, A.C., 1797.” The cups have long slender stems, with a round knob half-way; they are quite plain.
5. PATEN.—Plated copper. H. $4\frac{1}{4}$ in., diam. $7\frac{1}{2}$ in., foot $4\frac{1}{8}$ in. No marks. Inscription as follows, on an oval plate: “Hæc Patina Data est in Ufum Ecclesie Horwood parvæ a Stephano Langton, A.M., Vicario, A.C., 1797.” The Paten has a tall and very slender stem, and a slightly raised rim.
6. FLAGON.—Plated. H. $9\frac{7}{8}$ in., diam. top $4\frac{1}{4}$ in., base 6 in. No marks. Inscription on an oval plate: “Hæc Lagena Data est. [... &c. ...] 1797,” as on Nos. 3-5.
7. ALMSDISH.—Plated. H. $1\frac{3}{8}$ in., diam. 11 in. No marks. Inscription as on No. 5.
N.B.—Revd. Stephen Langton, son of Sir Stephen Langton, Lay-Rector and Patron of Little Horwood, was Vicar, 1792-1818.
8. ALMSDISH.—Gilded metal. H. $\frac{7}{8}$ in., diam. 12 in. Rich repoussée ornament; Sacred Monogram in the centre; modern, presented by Mrs. Dauncey in 1889.
9. SACRING-BELL?—A small bronze bell. H. $1\frac{1}{2}$ in., diam. $1\frac{1}{2}$ in. of church-bell shape, was found in the foundation of the Chancel during the restoration of 1889, and is supposed to be a Sacring-Bell.

St. Mary.

MURSLEY.

575.

1. CUP.—Silver. H. $7\frac{1}{2}$ in., diam. base $3\frac{1}{4}$ in., bowl $3\frac{1}{2}$ in., depth 4 in., w. 10 oz. 7 dwts. Hallmarks: London, 1794. Maker's mark: H. C. in oval (Henry Chawner, 1785-96). Cripps O.E.P.⁴, p. 387 (1788). Inscription: “*In usum Ecclesie Parochialis de Mursley in Com̄ Bucks, 1794.*” The cup has rather a deep bowl, and a tall stem with central swelling, and the characteristic multiple beading on the swelling and on the foot.

2. PATEN.—Plated. H. $\frac{1}{2}$ in., diam. 9 in. No marks. Quite plain.
3. FLAGON.—Pewter. H. 9 in., diam. top 7 in., base $6\frac{1}{2}$ in.
4. ALMSDISH, CANDLESTICKS (two pairs), etc.—Brass. Modern.

STEWKLEY.

St. Michael.

576.

1. CUP.—Silver. H. $7\frac{1}{4}$ in., diam. bowl $4\frac{3}{8}$ in., base $4\frac{1}{8}$ in., depth of bowl $3\frac{1}{2}$ in., [w.] 13 oz. 6 dwts. Hallmarks: London, 1654. Maker's mark: I.H. in pointed shield, a mullet above, a fish (?) below. This cup has a rather small bowl, and a tall stem with a prominent knob. It bears the following inscription, in plain script: "*Stewkley: John Pilkington: Rector: Thomas Prentice William Grace: Churchwardens: 1671.*"

The two Churchwardens of Stewkley kept separate accounts at this time, and under the year 1671 occur, among others, the two following entries:—

The Account of Thomas Prentice Churchwarden of Stewkley Anno Domj 1671	02 : 00 : 00
itm. for the silver cup	
The Account of William Grace Churchwarden of Stewkley Ano Domj 1671.	02 : 00 : 00
itm. for the silver cup	

This cup, if bought in 1671, must have come from elsewhere: and as its date falls under the Commonwealth, it may have been ejected at the Restoration

2. CUP.—Plated on hard metal. Gilt inside; modern. Inscribed, "Stewkley Parish."
3. PATEN ON FOOT.—Silver. H. $1\frac{5}{8}$ in., diam. $6\frac{7}{8}$ in., foot $2\frac{3}{4}$ in., [w.] 9 oz. 3 dwts. Hallmarks: London, 1723. Maker's mark: I. B. with mullet below, in trefoil shield (perhaps John Bignell (ent. 1720), *quatrefoil*, I B, mullet above and below, Cripps O. E. P.^t, p. 375). The foot is clumsy, and has probably been added to the paten, which without it would have been a very

usual type of salver. There is a scar inside the foot, which may be the vestige of a hallmark; but it is indecipherable. Inscription in plain script: *May it be accepted as the humble gift of Elizabeth Gurney, for the use of the sacred Temple of God at Stewkley, 1744.*

4. PATEN.—Plated on hard metal. Quite plain; modern. Belonging to No. 2.
5. FLAGON.—Plated on hard metal. Sacred monogram, within rays, engraved in front. Imitation hallmarks below the rim, (1) ? e in a round stamp, (2) ? a cup, in rounded rectangle, (3) uncertain object in rounded rectangle, (4) lion to left in rounded rectangle.
6. ALMSDISH.—Brass; modern. Sacred Monogram engraved in centre. Inscription round the rim: "*To do good and to distribute forget not.*"
A modern wooden box for bread, and two modern glass cruets are also in use.

SWANBOURNE.

St. Swithin.

577.

1. CUP.—Silver. H. $8\frac{5}{8}$ in., diam. base $3\frac{7}{8}$ in., bowl $4\frac{5}{8}$ in., depth, $4\frac{3}{4}$ in., [w.] 19 oz. 12 dwts. Hallmarks (under the foot): London, 1809. Maker's mark: T. R. in rectangular stamp. Inscription on the bowl: "*The Parish of Swanbourne | in the County of Bucks, | A.D. 1809.*" The cup has a nearly cylindrical but slightly swollen bowl, and a tall, very slender stem with central knob.

The following entry occurs in the Parish accounts:—

1809, Dec. 23, paid the Rev^d. Lemesures as per bill for a silver cup £11 17 0

2. PATEN ON FOOT.—Silver. H. $1\frac{3}{4}$ in., diam. $5\frac{3}{8}$ in., foot $2\frac{1}{8}$ in., [w.] 5 oz. 1 dwt. Hallmarks: London (old standard) 1724. Maker's mark: N. G., obliquely across a square stamp. The foot has been added, and the upper part has been

formerly a domestic salver. It bears the crest: *a griffin's head erased, with collar of vair*. It is probable that this vessel was bought at the same time as the chalice, as the price paid for the latter is excessive, and in that case the crest may be that of "the Rev^d. Lemesures."

3. **PATEN**.—Pewter. H. $\frac{3}{4}$ in., diam. $9\frac{1}{4}$ in. Counterfeit hallmarks: (1) E. B., (2) lion rampant to r., (3) griffin's head erased, to r., (4) crescent—all in rounded rectangles. Maker's marks: (5) crowned X, rampant horse on escutcheon below, (6) half obliterated, BETT ERM | IN | [L]ONDO[N]; on labels. In the centre of the underside are the letters $\begin{matrix} T & C \\ R & H \end{matrix}$. Thomas Curle was churchwarden 1765–6, and Robert Higgs parish clerk at the same time.

4. **FLAGON**.—Silver - plated copper. H. $11\frac{1}{2}$ in., diam. top $4\frac{1}{2}$ in., base $6\frac{3}{8}$ in. No marks. It is of the usual cylindrical type, with spout; the cover is unusually plain, and the foot very little wider than the body.

The following entry occurs in the parish accounts:—

1827, August 25. Paid for a flagon for the Communion as per bill, of Mr. Field £3 13 6

5. **ALMSDISH**.—Brass. H. $1\frac{1}{4}$ in., diam. 13 in. Foliated cross embossed in the centre; modern. Presented in 1880 by Hon. Emily and Louisa Fremantle.
6. **ALMSBOX OF WOOD**.—The type is the same as that at Whaddon (*q.v.*), but the body is deeper and octagonal; and the cover is returned into the box, so as to conceal the contents, leaving only a narrow slit. The handle is of turned walnut. This box seems to be of amateur workmanship, but perhaps replaces an older one. On the bottom is the inscription: "1842, K. M. P." Rev. Kenneth Mackenzie Pughe was Curate of Swanbourne during the incumbency of Rev. Charles Lucas Reay, 1838 to 1844.

TATTENHOE.

St. Giles (reconsecr. 1636).

578.

1. CUP WITH COVER-PATEN.—Silver. H. 7 in., diam. base $4\frac{1}{2}$ in., bowl $4\frac{1}{2}$ in., depth 4 in., [w.] abt. 12 oz. Hallmarks: London, 1662 (lion-stamp also inside the foot). Maker's mark: I N, with a rose below, in heart-shaped shield. (Cripps O. E. P.⁴ (1662), p. 361.) The cup is of the usual form for the period, and is quite plain.
2. COVER-PATEN OF THE CUP.—Silver. H. 1 in., diam. $5\frac{1}{2}$ in., foot $2\frac{1}{2}$ in. [w.] abt. 3 oz. Same hallmarks and maker's mark: quite plain.
3. FLAGON.—Plated. H. 9 in., diam. top 4 in., base $5\frac{1}{2}$ in. Of the usual cylindrical form, and quite plain.
4. ALMSDISH.—Plated. Diam. 8 in. A flat salver with scalloped edge.

WHADDON.

St. Mary.

579.

1. CUP WITH COVER.—Silver gilt. H. 10 in., diam. 5 in., bowl $3\frac{1}{2}$ in., depth 3 in., [w.] 18 oz. 5 dwts. Hallmarks: London, 1734. Maker's mark: I.S., within an oval of dots (Joseph Smith, entered 1728). Cripps O. E. P.⁴, p. 377, (1731). Bought 1734 (*vide* under No. 2).

The bowl is cylindrical, with hemispherical bottom, defined by a strong moulding. The stem is slender, with a pear-shaped swelling. Both cup and cover have the Sacred Monogram, with cross fitchée and nails, within rays. (Pl. i.)

This cup has still its original case of wood covered with stamped leather, and lined with green baize. The case has a cylindrical base 4 in. in diam. by $1\frac{1}{8}$ in. high, body $4\frac{1}{2}$ in. high, with narrower cylinder 2 in. by 2 in. for the stem; and ends above in a hemispherical cover; the total height is 9 in., but it does not now quite contain the knob of the chalice cover; it opens on vertical hinges into two equal halves.

2. CUP.—Silver (sold). The following entry in Whaddon Church Register has been brought to my notice by Mr. A. Clear, of Winslow:—

“In 1734 was bought a new Chalice w'ch cost £9. 8s. 0d.; the old one sold for £2. 15s. 0d., on w'ch was the date 1570, and no other graving.”

This must have been the Elizabethan Cup.

3. PATEN.—Silver. H. $1\frac{1}{2}$ in., diam. $8\frac{1}{2}$ in., foot 3 in., [w.] 14 ozs. 12 dwts. Hallmarks: London, 1683. Maker's mark: N W in plain shield. Inscription in script underneath: “*The Gift of Wm. Emmerton of y^e Middle Temple, London, Esquire.*” This is a domestic salver, and bears on the upper service the arms [] a chief [] dancetty: over all, on a bar, [] three lions passant [] (Emmerton): the tinctures are not indicated. Above, an esquire's helmet, with the crest, a *demi-lion rampant, holding a halbert*, all surrounded by foliage scrolls.
4. FLAGON.—Plated. H. 12 in., diam. top $3\frac{1}{2}$ in., base 7 in. This is of the usual cylindrical form, without a spout. It bears the counterfeit hallmarks;—(1) and (3) lion rampant. (2) $\overline{\text{II}}\overline{\text{CI}}$ partly obliterated. Engraved in front is the inscription: WHADDON; and the sacred monogram exactly as on the cup. The Flagon may very well be of about the same date as the Cup.
5. ALMSBOX OF WOOD.—The box is shovel-shaped, $6\frac{1}{4}$ in. long, $5\frac{3}{4}$ in. broad, and $1\frac{1}{2}$ in. deep; the upper side of it is partly covered in, leaving an opening next the handle 3 in. long, and the whole width of the box. The handle is straight, rising from the box by curved shoulders, and ends in a knob perforated from front to back for suspension. The total length is $14\frac{3}{4}$ in. At the base of the handle is carved the inscription: R P, 1643. The front and part of one side have been restored, and a duplicate of the whole box is in use together with it.

WHITCHURCH.

St. John the Evangelist.

580.

1. CUP WITH COVER.—Silver. H. $6\frac{3}{8}$ in., with cover $7\frac{7}{8}$ in., diam. base $3\frac{3}{8}$ in., bowl $3\frac{1}{2}$ in., depth $3\frac{7}{8}$ in., [w.] 10 oz. 19 dwts. Hallmarks: London, 1569. Maker's mark: H S linked, in plain shield (*cf.* Cripps O. E. P.⁴, p. 346 (1570), "probably Henry Sutton:" where the shield is *shaped*). On the handle of the cover "1570." This cup is of the usual pattern, with a rather elaborately interlaced band of ornament about one-third down the side. (Plate i. and ii. 2.)

This cup is mentioned in the Parish Register under date 1682, as follows:—

There is a silver chalice for the Comunion which is with silver cover, given to the Church in 1570, but by whom is unwritten.

- 2-3. PAIR OF CUPS WITH COVER-PATENS.—Silver. H. $8\frac{1}{8}$ in., diam. base 5 in., bowl $5\frac{1}{8}$ in., depth $5\frac{3}{8}$ in., [w.] 29 oz. 1 dwt. each. Hallmarks: London, 1669. Maker's mark: W M, one pellet (? mullet) below; crown of three roses above; in shaped shield. (*cf.* Cripps O. E. P.⁴, p. 362, (1668); 393 (1690). Sacred Monogram and cross engraved on the side.

These cups are of the quite plain heavy workmanship of the period, and are of unusual size. Their history is given in the Parish Register, under date 1682, as follows:—

Sir Edward Smyth, Kt., formertime Lord Chief Justice of Common Pleas in Ireland and Lord of this Manner gave to the parish church of Whitchurch *Two large Chalices* of perfect silver for the communion each of them weighing one pound (allowing sixteen ounces to the pound) and fifteen ounces, and containing a quart and half a pint.

The date of the gift is not quite certain. The cups were made in 1669, but the entry in the Register indicates that the flagon (No. 8), which was made in 1681, was given at the same time. If so, the entry must have been made immediately after their presentation.

Sir Edward Smyth (or Smith) was buried at Whitchurch, 26 Feb., 168 $\frac{1}{2}$, and was succeeded by a son of the same name.

- 4-5. COVER-PATENS OF THE CUPS 2-3.—Silver. H. 1 $\frac{3}{8}$ in., diam. 6 $\frac{3}{8}$ in., foot 3 in., [w.] 9 oz. 2 dwts. Quite plain, with feet; same marks as the cups; Sacred Monogram on the foot-handle.
- 6-7. ALMSDISHES OR PATENS.—Silver. H. $\frac{3}{4}$ in., diam. 10 in., [w.] 15 oz. 19 dwts. each. Hallmarks: London, 1668. Maker's mark: W M, as on the cups. Sacred Monogram in the centre. These are plain flat salvers, and were presented together with the cups; in the Register of 1682, already quoted, they are described as "Plates."
8. FLAGON.—Silver. H. 11 $\frac{3}{8}$ in., diam. top 4 $\frac{1}{2}$ in., base 6 $\frac{3}{8}$ in., [w.] 54 oz. 14 dwts. Hallmarks: London, 1681 (the stamp is peculiar, for the shield has its five angles produced into long points). Maker's mark: I M, with three pellets above and three below; within a ring of dots in a round stamp (*cf.* Cripps O. E. P.⁴, p. 393). In front, the Sacred Monogram engraved within rays, with cross above, and a heart pierced by three nails below. The Flagon is of the usual nearly cylindrical form.

N.B.—There exists, also in the Parish Register, another inventory of these vessels under date 7th May, 1822, made and signed by Rev. Thos. Archer (Vicar).

9-10.—Modern Brass Cross and Candlesticks.

PLATE I.

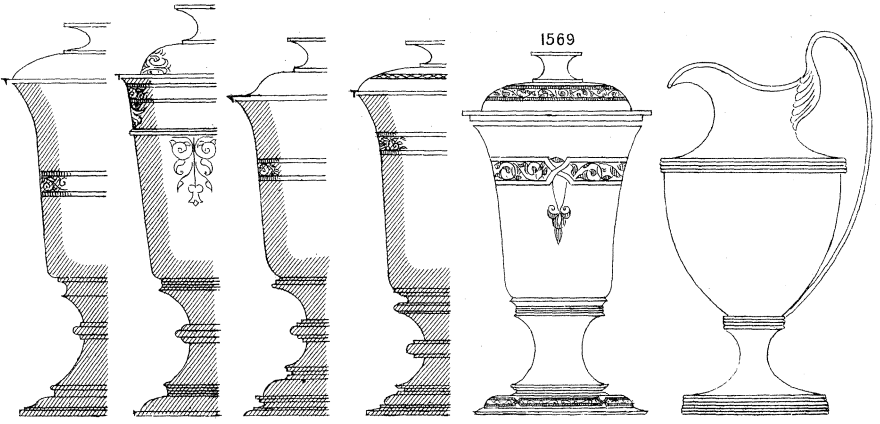

ASTON
ABBOTS.
1562

DRAYTON
PARSLOW.
1569

HOGGESTON.
1569

WHITCHURCH.
1569

1569

LITTLE
HORWOOD.
1562

DUNTON.
1811

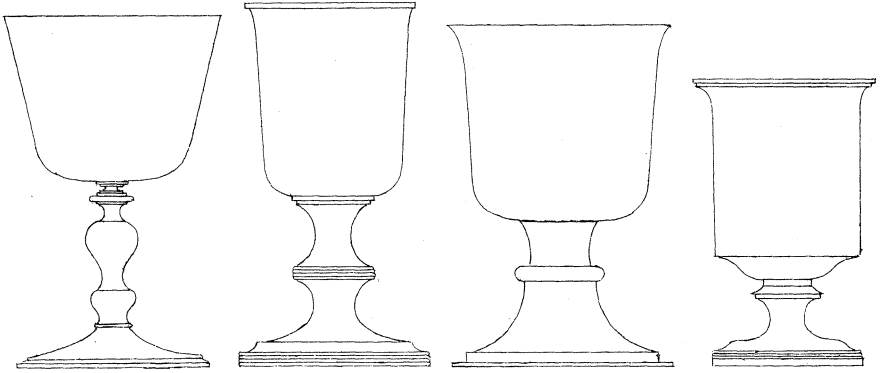

STEWKLEY.
1654

MURSLEY.
1794

TATTENHOE.
1662

DUNTON.
1809

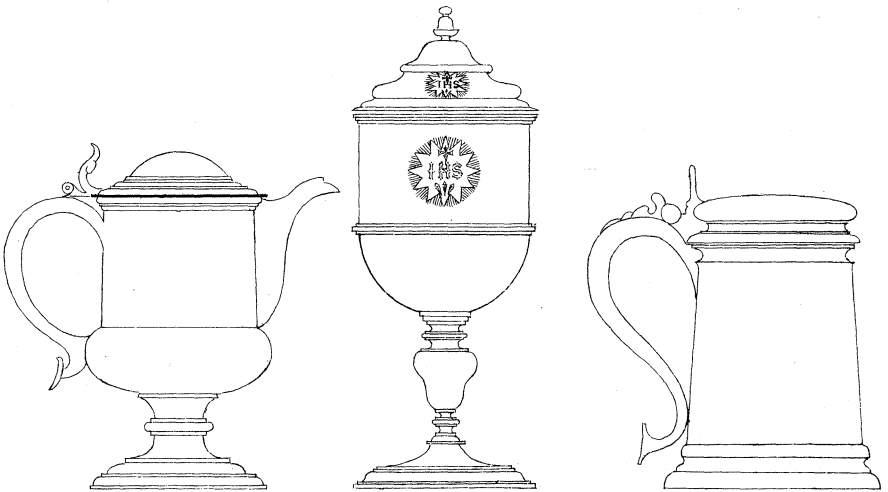

DRAYTON PARSLow,
c 1750

WHADDON,
1734

HOGGESTON.
1683

PLATE II.

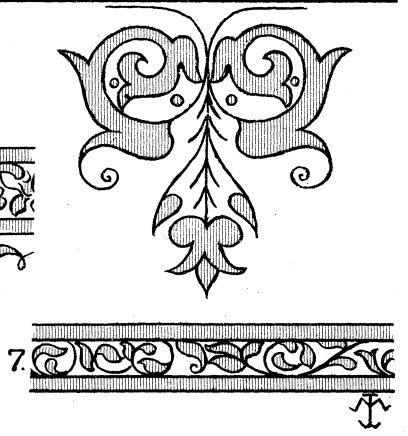
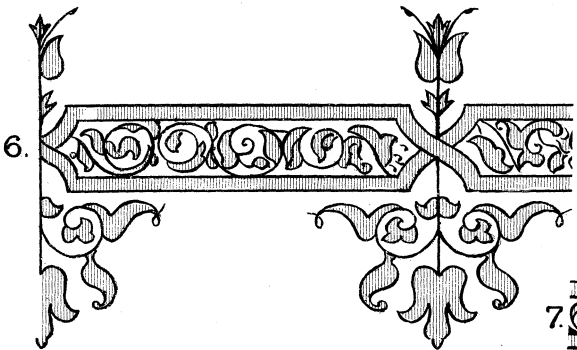
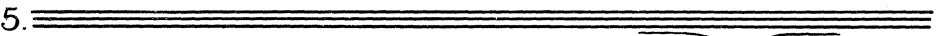
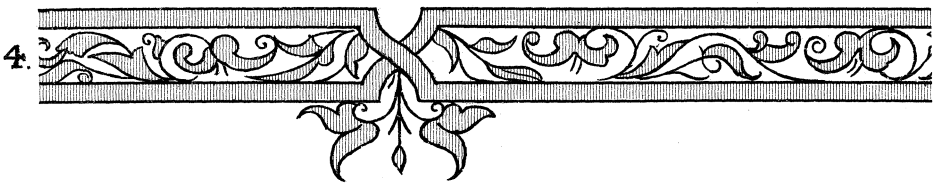
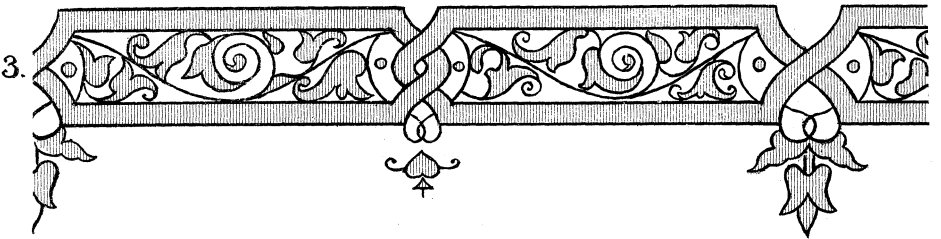
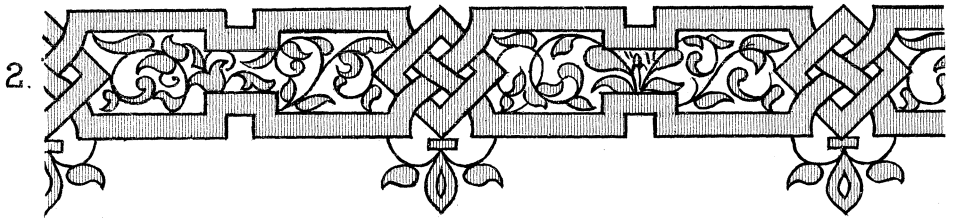
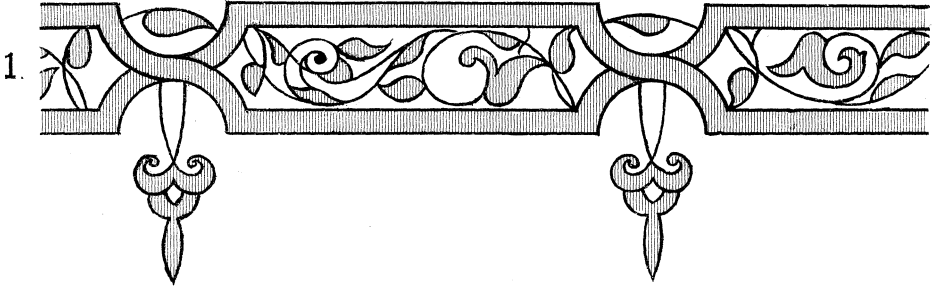

CHRONOLOGICAL SUMMARY OF THE SILVER
VESSELS.

Date.	Vessel.	Parish.	No.
1562	Cup with cover-paten..	Aston Abbotts ...	567
1562	Cup [cover missing]...	Little Horwood ...	574
1569	[Cup]cover-paten only	Little Horwood ...	574
1569	Cup	Drayton Parslow ...	569
1569	Cup	Hoggeston ...	572
1569	Cup	Whitchurch ...	580
1654	Cup	Stewkley ...	576
1662	Cup with cover-paten..	Tattenhoe ...	578
1668	Almsdishes	Whitchurch ...	580
1669	Cups with cover-patens	Whitchurch ...	580
1681	Flagon	Whitchurch ...	580
1683	Tankard (as flagon)...	Hoggeston ...	572
1683	Paten	Whaddon ...	579
1692	Cup with cover	Cublington ...	568
1697	Patens (pair of)	Great Horwood ...	573
1718	Paten	Hardwicke ...	571
1723	Paten	Stewkley ...	576
1724	Paten	Swanbourne... ..	577
1734	Cup with cover	Whaddon ...	579
1755	Flagon	Great Horwood ...	573
[1756]	Cup (missing)	Drayton Parslow ...	569
1794	Cup	Mursley ...	575
1809	Cup	Swanbourne... ..	577
1809	Cup	Dunton ...	570
1811	Paten	Dunton ...	570
1811	Ewer (as flagon)	Dunton ...	570
1811	Almsdish	Dunton ...	570
1870	Flagon... ..	Hardwicke ...	571
1871	Paten	Hardwicke ...	571
1872	Cup	Hardwicke... ..	571
1873	Chalice... ..	Great Horwood ...	573

JOHN L. MYRES.