



# **Clitheroe Castle, Clitheroe, Lancashire**

## **Archaeological Building Investigation**



**Oxford Archaeology North**

September 2008

**Turner and Townsend and  
English Heritage**

Issue No: **2008-09/803**

OAN Job No: L9899

NGR: SD 7424 4169

Planning Application 3/2006/1047 and  
3/2007/0039

**Document Title:** Clitheroe Castle, Clitheroe, Lancashire

**Document Type:** Archaeological Building Investigation

**Client Name:** Turner and Townsend and English Heritage

**Issue Number:** 2008-09/803

**OA Job Number:** L9899

**National Grid Reference:** NGR SD 7424 4169

Prepared by: Karl Taylor  
Position: Project Officer  
Date: September 2008

Checked by: Jamie Quartermaine Signed.....  
Position: Senior Project Manager  
Date: September 2008

Approved by: Alan Lupton Signed.....  
Position: Operations Manager  
Date: September 2008

**Oxford Archaeology North**

Storey Institute  
Meeting House Lane  
Lancaster  
LA1 1TF  
t: (0044) 01524 848666  
f: (0044) 01524 848606

w: [www.oxfordarch.co.uk](http://www.oxfordarch.co.uk)  
e: [info@oxfordarch.co.uk](mailto:info@oxfordarch.co.uk)

**© Oxford Archaeological Unit Ltd 2008**

Janus House  
Osney Mead  
Oxford  
OX2 0EA  
t: (0044) 01865 263800  
f: (0044) 01865 793496

Oxford Archaeological Unit Limited is a Registered Charity No: 285627

**Disclaimer:**

*This document has been prepared for the titled project or named part thereof and should not be relied upon or used for any other project without an independent check being carried out as to its suitability and prior written authority of Oxford Archaeology being obtained. Oxford Archaeology accepts no responsibility or liability for the consequences of this document being used for a purpose other than the purposes for which it was commissioned. Any person/party using or relying on the document for such other purposes agrees, and will by such use or reliance be taken to confirm their agreement to indemnify Oxford Archaeology for all loss or damage resulting therefrom. Oxford Archaeology accepts no responsibility or liability for this document to any party other than the person/party by whom it was commissioned.*

## CONTENTS

---

<b>CONTENTS.....</b>	<b>1</b>
<b>SUMMARY .....</b>	<b>4</b>
<b>ACKNOWLEDGEMENTS .....</b>	<b>6</b>
<b>1. INTRODUCTION.....</b>	<b>7</b>
1.1 Circumstances of the Project	7
1.2 Site Location and Topography	7
<b>2. METHODOLOGY.....</b>	<b>8</b>
2.1 Introduction	8
2.2 Building Investigation	8
2.3 Archive	9
<b>3. HISTORICAL BACKGROUND.....</b>	<b>10</b>
3.1 Historical Background	10
3.2 Map Regression Analysis	11
<b>4. BUILDING INVESTIGATION RESULTS.....</b>	<b>13</b>
4.1 Introduction	13
4.2 The Arrangement of the Buildings	13
4.3 Museum Layout and Fabric	14
4.4 Museum Exterior	15

4.5	Museum	Interior	-	Ground	Floor
18					
4.6	Museum	Interior	-	First	Floor
23					
4.7	Museum	Interior	-	Second	Floor
26					
4.8	Museum	Interior	-	Basement	
27					
4.9	Sound	Archive	and	Court	House
28					Layout and Fabric
4.10	The	Sound	Archive	-	Exterior
29					
4.11		Court		House	Exterior
31					
4.12	Sound	Archive	-	Internal	Details
32					
4.13	Court	House	-	Internal	Details
37					
4.14			The		Gateposts
38					
<b>5. DISCUSSION.....</b>					<b>39</b>
5.1					Introduction
39					
5.2	The		Museum		Building
39					
5.3	The	Sound	Archive	and	Court
42					House
5.4			The		Gateposts
44					
<b>6. BIBLIOGRAPHY.....</b>					<b>45</b>
6.1	Primary	and	Cartographic		Sources
45					

6.2				Secondary	Sources	
45						
<b>APPENDIX 1: PROJECT BRIEF.....</b>						<b>47</b>
<b>APPENDIX 2: PROJECT DESIGN.....</b>						<b>55</b>
		1.			Introduction	
56						
	3.6	Building	Description	and	Analysis	
58						
<b>ILLUSTRATIONS.....</b>						<b>61</b>
	List	of	Figures			
61						
	List	of	Plates			
61						

---

## SUMMARY

---

Planning applications have been submitted by Ribble Valley Borough Council outlining details of alteration, restoration and adaptation to the Museum, Sound Archive and Court House at Clitheroe Castle, Clitheroe, Lancashire (SD 7424 4169). In particular, it is proposed that the Museum is extended, which will necessitate the erection of a new building, as a consequence English Heritage and Lancashire County Archaeological Service (LCAS) required that a record of the buildings be made in advance of the construction work. OA North, acting on behalf of Turner and Townsend, submitted a project design for the recording programme in response to a brief by LCAS. Clitheroe Castle is situated at the southern end of Clitheroe town and is a designated Scheduled Monument (SM 27747), which incorporates several structures, including Grade I and Grade II Listed Buildings; it is situated in both a Registered Park and Garden and Clitheroe Conservation Area.

Three buildings within the complex at Clitheroe Castle were subject to investigation. These were the main Museum building, the building housing the North West Sound Archive and the former Court House, of which the latter two structures form the southern end of the Stable Range.

The building investigations at Clitheroe Castle consisted of two main levels of recording.. Those areas where intervention is intended to be intrusive, recording to English Heritage Level III (English Heritage 2006) survey was carried out, which included survey work to record the elevations. In addition an outline description of all the buildings (internal and external) was carried out to English Heritage Level II standard, which incorporated a full photographic survey and included areas where changes to the fabric are intended to be minimal or minor repairs are to be carried out .

Clitheroe Castle is first referred to in 1102, when an area of land below 'le baille' is mentioned. There may have been a Saxon predecessor to the castle, perhaps comprising a wooden palisaded enclosure. Further studies suggest that there was castle in the time of Domesday although evidence for this is scant. The extant keep is of a square plan with three storeys, and is the second smallest surviving keep in England. It was originally surrounded by a curtain wall with a gatehouse built into the south-east, although this has since been demolished. The castle yard contained the chapel of St Michael in Castro, which is likely to have been contemporary with the keep. The chapel was ruinous by 1660, and the keep and the curtain walls were in a similar condition by the early eighteenth century, although roofed buildings continued to occupy the castle yard. As the castle retained its function as the administrative centre for the Blackburn Hundred in the eighteenth and nineteenth centuries, considerable rebuilding was carried out in an attempt to bring the castle up to date and entailed the construction of a large stable block, a Court House and a Steward's House (now the Museum), which are depicted on a plan of the castle dated 1723.

The building investigation and cartographic evidence has revealed that the Grade II Listed Museum building was on the footprint of an earlier structure which was illustrated on a reconstruction drawing dated to 1723. The Museum building probably dates to the late eighteenth century and, is an example of eighteenth century 'gothick' revival. It went through three major phases of construction and had attained the final current footprint by 1886 (OS first edition 1:2500 map).

---

---

The Sound Archive and Court House have undergone four main phases of construction in the late eighteenth and early nineteenth centuries. Both buildings contain distinctive decorative fabric in the nineteenth century gothic revival tradition. Earlier buildings illustrated on early engravings have been partly demolished but traces of the earlier fabric still survive in the extant buildings.

---

---

## ACKNOWLEDGEMENTS

---

Oxford Archaeology North (OA North) would like to thank Turner and Townsend for commissioning the project, and in particular Emma Birkett for her support. We would also like to thank Jennie Stopford, English Heritage, and Peter Iles, Lancashire County Council for their advice and help. Thanks are also due to Rod Pearce, Ribble Valley Borough Council, for his support.

The building investigation was carried out by Pip Haworth, Chris Ridings and Karl Taylor. The report was written by Karl Taylor, and the drawings were produced by Alix Sperr and Anne Stewardson. The project was managed by Jamie Quartermaine, who also edited the report.

---



---

# 1. INTRODUCTION

---

## 1.1 CIRCUMSTANCES OF THE PROJECT

- 1.1.1 Planning applications submitted by Ribble Valley Borough Council (RVBC), 3/2006/1047 and 3/2007/0039, outline details of alteration, restoration and adaptation to the Museum, Sound Archive and Court House at Clitheroe Castle, Clitheroe, Lancashire (SD 7424 4169). A project brief (*Appendix 1*), outlining a programme of archaeological building investigation and recording, was issued by Lancashire County Archaeology Services (LCAS) to Turner and Townsend, who are acting on behalf of Ribble Valley Borough Council. A project design outlining a scheme of building recording, was submitted by Oxford Archaeology North (OA North) to Turner and Townsend in accordance with the brief.
- 1.1.2 The Museum building is Grade II Listed, and the entirety of the castle precinct is a Scheduled Monument (SM27747). The southern part of the precinct, including the Museum, Sound Archive and Court House buildings is the focus of a wide-ranging scheme of restoration and adaptation. In particular, it is proposed that the Museum is extended and connected to the Sound Archive and Court House, which comprises the erection of a new building. The footprint of the proposed new building lies within the Scheduled Monument and, therefore, an archaeological evaluation was carried out to establish the presence and extent of any buried remains (OA North 2007). The evaluation and the building survey were undertaken to inform an application for Listed Building and Scheduled Monument Consents to undertake the proposed Museum extension and building adaptations.
- 1.1.3 Following the acceptance of the project design (*Appendix 2*), OA North was commissioned by Turner and Townsend to carry out the building investigations. This report sets out the results of these investigations.

## 1.2 SITE LOCATION AND TOPOGRAPHY

- 1.2.1 Clitheroe castle is located on a limestone knoll, to the south of the historic core of Clitheroe town centre (Fig 1). The walled ward of the castle is dominated by the keep on the pinnacle of the knoll, and below this and to the east, and south, are a series of buildings - the Museum, the former North West Sound Archive and the former Court House – which are in-part incorporated into the curtain walls of the ward.
  - 1.2.2 The underlying solid geology is composed of the carboniferous limestone series (Tournaisian and Viséan), while the general overlying deposits of the town are classified as glacial till (British Geological Survey 1970; Earp *et al* 1961).
-

---

## 2. METHODOLOGY

---

### 2.1 INTRODUCTION

2.1.1 The building investigations at Clitheroe Castle consisted of two main levels of recording as outlined in the project design (*Appendix 2*). A level II survey was applied across the extent of the structures, which included those parts of the buildings where changes to the fabric are intended to be minimal, or where minor repairs are to be carried out, were subject to a photographic survey. This comprised the production of plans, detailed photography and a descriptive record of all the buildings (internal and external) (English Heritage 2006). On those parts of the building where intervention was intended to be more intrusive, recording was undertaken to English Heritage Level III, and included surveys of the elevations (*Appendix 3*).

### 2.2 BUILDING INVESTIGATION

2.2.1 **Descriptive Record:** written records to English Heritage Level II (*ibid*) standard using OA North *pro-forma* record sheets were made for all principal building elements, both internal and external, as well as any features of historical or architectural significance. Particular attention was paid to the relationship between the various parts of the buildings, especially those that would reveal development of the structure and any alterations that were applied. These records are essentially descriptive, although the interpretation of the structure was made as appropriate.

2.2.2 **Site drawings - Level 3 record:** in accordance with the brief, plans were produced for all floors of the Museum, Court House, and Sound Archive. In addition cross sections were produced through all three buildings. In addition, the following select elevations were recorded to this level:

- South-facing Elevation the Stable Range (Sound Archive)
- North-, west- and south-facing elevations within the courtyard between the south end of the Stable Range (Sound Archive) and the Court House.
- West-facing elevation of the Court House to the Archive Room
- Entrance gate pillars at the north-eastern corner of the ward.
- Southern elevation of the Museum
- Western elevation of the Museum

2.2.3 **Plans and Elevations:** architects plans of these buildings were enhanced and annotated to show the form and location of all structural features of historic significance. The additional detail was created by means of manual survey and annotation of paper copies. The corrected drawings were digitised into an industry standard CAD package (Autocad 2004) for the production of the final drawings. The elevations were enhanced so as to depict all decorative and significant stonework, such as quoins, tracery, window and door surrounds, but will not show all stones.

2.2.4 **Cross-Sections:** the cross-sections were created by the annotation of existing drawings, and with the addition of data from a reflectorless total station. The data from the instrument was combined with the earlier survey base within a CAD

---

---

system and output as a series of plots to enable further enhancement of the drawing by manual survey.

- 2.2.5 **Photographs:** photographs were taken in black and white print and colour slide 35mm SLR formats, as well as 10 megapixel DSLR jpg images. The photographic archive consists of both external and internal views of the buildings and detailed photographs of specific architectural details. Some of the internal rooms were of small dimensions and were photographed from restricted viewpoints, resulting in a limited record. External photography was similarly limited by the availability of appropriate viewpoints, which, because of steep slopes immediately adjacent to the walls, did result in restricted coverage.

### 2.3 ARCHIVE

- 2.3.1 The results of all archaeological work carried out will form the basis for a full archive to professional standards, in accordance with current English Heritage guidelines (*Management of Archaeological Projects*, 2nd edition, 1991). The original record archive of project will be deposited with Lancashire County Record Office
- 2.3.2 The Arts and Humanities Data Service (AHDS) online database *Online Access to index of Archaeological Investigations* (OASIS) will be completed as part of the archiving phase of the project.
-

---

## 3. HISTORICAL BACKGROUND

---

### 3.1 HISTORICAL BACKGROUND

- 3.1.1 **Prehistoric and Roman:** Clitheroe lies on one of the important trans-Pennine trade routes through the Ribble Valley - Aire gap. Evidence of a trade in prestige items, such as Neolithic stone axes, have been found around Clitheroe, including a find spot at Upbrook Farm to the east of Clitheroe (Kenyon 1991, 35). Little other direct evidence for the prehistoric period in general exists for Clitheroe, but there are two known prehistoric findspots from the urban area defined for Clitheroe, including a Late Bronze Age socketed axe head and a stone mace head discovered in the environs of Salt Hill (Lancashire County Council 2006, 14). It has been postulated that the medieval de Lacy honour centred on Clitheroe was located to exploit the same strategic territory as the hillforts of Castercliffe and Portfield (Kenyon 1991, 52).
- 3.1.2 The Roman period is similarly under-represented, with the main Roman occupation in the Ribble Valley, centred on nearby Ribchester. The only known Roman remains in the area is a section of the road between the Roman forts at Ribchester and Ilkley, which passes within 1km of Clitheroe Castle (Codrington 1919, 100).
- 3.1.3 **Medieval:** evidence for an occupation of the wider area during the early medieval period may be drawn from nearby Whalley, where there are groupings of pre-Conquest sculpture within the churchyard (Newman 1996, 99). However, Clitheroe does not appear to have constituted a settlement at the time of Domesday, despite place-name evidence suggesting Anglo-Saxon origins (Lancashire County Council 2006, 14).
- 3.1.4 Much more is certain about the later medieval development of Clitheroe. It was a large landholding which had been acquired by the de Lacy family by 1102 (Best 1990, 4), who created the borough of Clitheroe between 1146 and 1177 as a successor to the eleventh-century hundredal estate of Blackburn (Farrer and Brownbill 1911, 367). It has been suggested, however, that the borough charter was only a confirmation of status for an existing settlement (White 1996, 127). Clitheroe certainly developed during the twelfth century, with the erection of the stone castle and, by 1122, the parish church of St Mary Magdalene. The castle was sited on top of a natural vantage point at the south end of the present town, and the parish church lay to the north. The town developed around the lower ground between the castle and the church, providing an indication of the size of the medieval settlement; documentary evidence identifies 66 burgesses resident in the town by 1258 (Farrer and Brownbill 1911, 367). A market in Clitheroe was not actually documented until 1292, although it was claimed at that date that there had been a market in existence from the Conquest (*op cit*, 368). Evidence to corroborate this claim, however, is lacking (Lancashire County Council 2006, 16).
- 3.1.5 The castle itself is first referred to in 1102, when an area of land below 'le baille' is mentioned. It has been argued, although without any corroborating evidence, that there was a Saxon predecessor to the castle, perhaps comprising a wooden palisaded enclosure (Langshaw 1947, 10). Similarly, it has been argued by Whitaker, in 1872, that there was castle at the time of the Domesday survey in 1086. He suggested that a castle mentioned under the Domesday entry for Barnoldswick was that of
-

---

Clitheroe, but this castle has never been accurately placed (Adams 2006, 180; Best 1990, 2). Nevertheless, the Norman castle does appear to have been an early foundation (Lancashire County Council 2006, 14). The extant keep is of a square plan with three storeys, and is the second smallest surviving keep in England. It was originally surrounded by a curtain wall with a gatehouse built into the south-east, although this has since been demolished. The castle yard contained the chapel of St Michael in Castro, which is likely to have been contemporary with the keep (Farrer and Brownbill 1911, 363). Other buildings within the castle courtyard included a large stable block, a court house and a dwelling house, which incorporated a dairy, a buttery and a cellar: these buildings are depicted on a plan of the castle dated 1723 (Best 1990, 14).

- 3.1.6 In addition to the strategic value of the castle, it was also the centre of local government during the medieval period, as the seat of the honour of Clitheroe, with courts being held there and also acting as a gaol (Adams 2006, 180).
- 3.1.7 **Post-medieval:** whilst Clitheroe experienced a period of economic growth in the sixteenth century, returning two members to the House of Commons in 1558, the castle began to decline in importance and was in need of repair (Best 1990, 11). Surveys in the early 1600s described the castle as ruinous, with the cost of repairs spiralling to £177 in 1608 (*ibid*).
- 3.1.8 The castle was occupied briefly during the Civil War in 1644 and 1649, and was ordered to be slighted later in the same year; there is some debate whether this was ever carried out. Nevertheless, the chapel was ruinous by 1660, and the keep and the curtain walls were in a similar parlous condition by the early eighteenth century, although roofed buildings continued to occupy the castle yard. Improvements to the buildings were undertaken by the late eighteenth century with the rebuilding of the Stewards House. As the castle retained its function as the administrative centre for the Blackburn Hundred until 1822, when a new town hall was begun in Church Street, considerable rebuilding was carried out in an attempt to bring the castle up to date, which included the rebuilding of the Court House (*op cit*, 13-5). However, it seems that the repair work to the keep was insufficient, as it was considered to be in danger of collapse by the early nineteenth century. In 1848, a decision was made to partially restore the ruins of the keep, and buttresses were built against three corners (Farrer and Brownbill 1911, 363).
- 3.1.9 In 1919, the then owner of the castle, Lord Montague of Beaulieu, offered to sell the site to the people of Clitheroe. The funds were raised by public subscription, and the castle and its 17-acre grounds were converted into a war memorial to those who lost their lives in the Great War (Adams 2006, 180-3). The present chapter in the history of the castle dates to 1981, when a museum opened in the castle house. More recently, the North-West Sound Archive occupied the outbuildings in the castle yard.

## 3.2 MAP REGRESSION ANALYSIS

- 3.2.1 Several historic cartographic sources were consulted in order to trace the physical development of the buildings under investigation.
  - 3.2.2 **Early eighteenth century sketch plan of Clitheroe Castle (Best 1990):** this is an inaccurate and poorly provenanced sketch plan of the castle depicted in Best 1990. It shows a simple four celled building (Steward's House) on the site of the
-

---

Museum, which does not correspond with the layout of the present Museum and it is to be presumed that this was the fore-runner of the present Museum structure. Two separate single celled structures were depicted in the locations of the later Sound Archive and Court House.

- 3.2.3 ***Ordnance Survey first edition 6" map 1847 (Fig 18)***: this map clearly shows the layout of the castle and the grounds and illustrates the Museum building and the range of buildings at the west side of the ward. The range is depicted as two separate structures and it is apparent that the Sound Archive building was detached from the rest of the Stable range and linking corridor was then not visible. The layout of the Steward's House is difficult to discern but appears to be similar to the current layout of the present Museum building.
- 3.2.4 ***Ordnance Survey first edition 25" map 1886 (Fig 19)***: this map is much clearer and illustrates the detailed layout of the castle. The Sound Archive building was by this date linked to the Court House by a narrow corridor. The layout of the Museum building was clearly depicted and was then identical to its current footprint (Fig 2). A glazed structure was attached to the south end of the building, and a small circular structure, probably the well, was illustrated.
- 3.2.5 ***Ordnance Survey 1914 and 1932***: these maps are of poor quality but the general layout of the various structures appears to have changed little.
-

---

## 4. BUILDING INVESTIGATION RESULTS

---

### 4.1 INTRODUCTION

- 4.1.1 Three buildings within the complex at Clitheroe Castle were subject to recording to English Heritage Level II/III standard (Fig 2). These were the main former Museum building, the building housing the North-West Sound Archive and the former Court House. At the time of survey, all of these buildings were unoccupied and in good condition. Most services had been disconnected, and many of the fixtures and fittings had been removed. The Museum building, however, still contained display fixtures and fittings (particularly on the first floor) which obscured much of the fabric, and this inevitably limited the scope of the survey in these areas.
- 4.1.2 The buildings under investigation are described below, with an outline of the plan form and function of each building presented together with information on any relevant architectural and historical features, fixtures and fittings. In addition, two gateposts, forming the principal entrance to the Castle Ward, are described and discussed at the end of this section (*Section 4.13*).

### 4.2 THE ARRANGEMENT OF THE BUILDINGS

- 4.2.1 The buildings are situated at the south end of the ward, the Museum building being the southernmost and is the first structure encountered when entering the castle grounds via the drive (Plates 1 and 2; Fig 2). The Sound Archive and Court House buildings are located to the north-west of the Museum building and form part of the range of buildings at the western side of the ward (Plate 3).
- 4.2.2 The Museum building stands alone and forms part of the south boundary of the ward and lies on a north-east/south-west axis. It is entirely separate from the Sound Archive and Court House buildings and comprises three main areas, including a front 'wing' and rear extension (Fig 2). The Sound Archive building lies on a north-north-east/south-south-west axis and the Court House lies almost due north/south. The Sound Archive and Court House buildings are connected by a corridor on both the ground and first floors.
- 4.2.3 For the purposes of the present survey, all the elevations of the buildings will be described in accordance with their direction to the main cardinal points. This means that the principal facade of the court house and Sound Archive buildings which faces east-south-east will be described as the east elevation (Fig 2), and the main (front) elevation of the Museum building which faces north-east, will be described as the north-east elevation. All the other elevations will follow suit.
- 4.2.4 A small grassed area is situated at the south end of the Sound Archive and west of the Museum building which is bounded by the curtain wall to the west and south. A walkway is situated on top of the curtain wall and two paths allow access to a small stone shelter located in the south-west corner of this area. In the centre of this area is a small circular structure which is a former well.
-

---

### 4.3 MUSEUM LAYOUT AND FABRIC

- 4.3.1 **Layout:** the main part of the Museum is laid out over three storeys together with a basement (Figs 3-6 and 9). There is a square 'tower' at the north-east corner and a rear 'extension', which is of two storeys. The building is constructed on the edge of the slope at the southern end of the castle ward resulting in the basement being accessible from ground floor level on the south-east side of the building. The whole building is asymmetrical and is approximately 28m long by 16m wide (at the longest and widest points).
- 4.3.2 **Museum - External Fabric:** the Museum building comprises three distinct parts, all of which have different construction detail. The north-eastern two thirds of the building is of three storeys and is constructed from random coursed (north-east and north-west elevations) and un-coursed (south-east elevation) rubblestone of sandstone with some limestone with smeared, mainly cement mortar. The sandstone is quite distinctive with approximately 50% exhibiting mineral veining. Sandstone quoins are present, of which some exhibit furrow toolmarks. Most of the walls are approximately 0.8m thick.
- 4.3.3 The rear part of the main building, as visible on the south-western part of the north-west elevation (not the rear extension), is constructed from random limestone (Plates 4 and 5), which continues around the corner onto part of the south-west elevation, and is of better quality than the other parts of the building. The quoins, however, are sandstone and of a similar appearance to those already described. The rest of the fabric (north-eastern part) of the south-west-facing elevation is similar to the north-eastern parts of the building (*Section 4.3.2*). A two-storey 'rear extension' is located at the rear of the building, which is constructed from un-coursed random rubble, comprised mainly of sandstone but with a some limestone fabric (Plate 6).
- 4.3.4 A low crenelated parapet is located at the top of each elevation, which is constructed from a mixture of sandstone and limestone fabric, with a sandstone coping. The parapet of the two-storey extension, at the south-west end of the building, differs slightly in that it is slightly lower (Plates 4 and 6). Lead flashing has been inserted into the join between the parapet and the main part of the wall on all the elevations. All the chimneys are constructed from sandstone ashlar (Plate 6), and all the window surrounds are of sandstone, some of which is degraded in places. All of the windows are timber framed.
- 4.3.5 A balcony is located on the south-east elevation, which is constructed from sandstone and has wrought iron railings with substantial sandstone ballusters. There are sandstone steps and the whole assemblage rests on piers of random rubblestone construction. There are four buttresses, also of random rubblestone construction, with sandstone quoins (Plate 7). The front north-east elevation contains a porch which is of fine sandstone construction and has glazed timber doors (Plate 8).
- 4.3.6 The roof is of slate which appears to be of late twentieth century origin and has concrete ridge tiles with ventilation slits (Plate 9). Lead-lined channels are covered partially with timber duck boards. All the rainwater goods are of cast iron.
- 4.3.7 An additional structure formerly existed at the rear of the Museum, and was originally a greenhouse or orangery. It may have been partially constructed from brick and there is some handmade brick fabric visible adjacent to the curtain wall. The floor of this structure is mainly concrete and sandstone but some encaustic tiles are also visible.
-



- 
- 4.3.8 ***The Museum - Internal Fabric:*** internally, the Museum comprised plain plastered solid walls with some internal plasterboard and lath and plaster partitions. All the floors are of timber construction with the exception of the basement and some of the ground floor rooms, which are either flagged or tiled. Some decorative plaster ceilings are evident on the ground floor. Much late-twentieth century fabric (such as museum displays) remains, particularly on the ground and first floors. Modern carpets cover some of the floors.

#### 4.4 MUSEUM EXTERIOR

- 4.4.1 ***North-East Elevation:*** the principal north-eastern elevation of the Museum contains the main entrance, located within a single storey porch which butts against the elevation and appears to be a later addition (Plates 8 and 13). The porch is of Jacobean Revival style and exhibits a round-headed arched doorway with three prominent key stones (Plate 8). There are two blind windows or niches on each side and the whole feature has a flat roof and has two ball finials at the corners. It is probable that an earlier doorway formerly existed here.
- 4.4.2 The elevation comprises two main parts, the south-eastern third comprises the tower which projects from the main elevation (Plate 13). It contains twin, lancet-arched fenestration with flush surrounds, on all three floors. All the window frames are one-over-one timber sliding sashes without horns and with concealed sash-boxes. The ground floor windows are slightly taller than the others. The main two thirds of the elevation contains mixed fenestration. The windows on the first and second floors at the south-east side are similar to those in the tower, with those on the first floor being taller. The other fenestration consists of timber-mullioned windows with chamfered surrounds; the frames are timber one-over-one sliding sashes without horns. The windows on the top floor are not as tall as the others. Some of the window surrounds exhibit weathered furrow tool marks, and the quoins are similarly weathered.
- 4.4.3 There is a low plinth at the south-east side of the elevation and a small flower bed with sandstone kerbstones is present at the north-west end. Sandstone mounting steps are present at the north-west corner of the building. A crenelated parapet is present at the top of the elevation, which was probably a later addition.
- 4.4.4 ***South-East Elevation:*** the south-east elevation is of four storeys and access to it from the front of the building is via a flight of stone steps (Plate 14). These are plain (some worn) and have a solid stone balustrade with moulded handrail. This leads to a path which allows access to the gardens at the foot of the terrace slope, out with the castle curtain wall.
- 4.4.5 The elevation has two projecting areas at the north-east and south-west ends (Plate 15); the north-east projection is part of the 'tower' described in *Section 4.4.2*. It is windowless on the east face and is of plain appearance. The south-west face of the tower, as observed from the balcony, contains three blocked narrow, lancet window apertures (basement, ground and first floors) (Plate 16). These have flush sandstone surrounds of similar appearance to those already described, which are partially obscured, indicating that the tower represents an earlier phase of construction.
- 4.4.6 The central part of the elevation has six windows across its width and varies between three and four storeys high (including the basement). The south-western part of the elevation is three storeys high; it is part of the rear extension (Plate 15),
-

---

and it is evident that it has been built against the main building, as quoins are visible within the fabric which show the extent of the original structure (Plate 17). The fenestration is mixed but mainly consists of lancet-arched windows of similar appearance to those already described. Some of the surrounds have been repaired with cement render and one appears to have been recently replaced with new sandstone. A blocked narrow lancet window is partially visible from the steps leading to the balcony (Plate 18; Fig 10).

- 4.4.7 There are two larger windows located in the centre of the elevation at ground floor level (Plate 15); these are tall (full height internally) and have sandstone sills and lintels. The frames have timber mullions and transoms. These windows may once have housed doors, which allowed access to the balcony. The balcony is at ground floor level and is partly supported by two substantial piers of mixed limestone and sandstone fabric, each with large quoins (Plate 15). The piers incorporate buttresses and their primary function appears to support this side of the building, although a blocked lancet window in one of the piers once allowed light into the basement. Further buttresses of similar fabric are built against the elevation and were evidently later additions. The balcony is constructed from well-finished, fine sandstone flagstones and has twisted wrought iron railings between seven decorative sandstone ballusters. They have a similar architectural style to the porch on the front elevation, and there is possibility that the balcony and porch were contemporary. At the time of the survey the only access to the balcony was via sandstone steps located at the north-east end (Plate 19). There is a wrought iron gate which is quite decorative and of nineteenth century appearance.
- 4.4.8 Access to part of the basement is available via a modern louver door located at the south-west end of the central part of the elevation (Plate 20). It has a stone segmental arch and an iron door, as well as a further wooden door external to the iron one; the iron door was put in place before the timber one. The wooden door is plain with ventilation holes and is hung on wrought iron pintles with strap hinges. To the left of this is a limestone pier, containing a niche with a stone shelf, which was presumably built to support the balcony above. A lancet window is located further to the left, which is of similar appearance to the others already described. All the rainwater goods are of cast iron, one of the down spout brackets sports a relief rose motif with the letter 'C' (Plate 21).
- 4.4.9 ***South-West Elevation (Fig 7):*** the south-west elevation is in two parts due to the addition of the two storey extension (Plate 6). The visible areas of the upper part of the south-west elevation, comprising the main part of the original structure will be described first, and the elevation of the later extension will be described second.
- 4.4.10 Most of the south-west end of the main part of the Museum is now obscured by the extension and access to the roof of the extension was gained via a window located in Room **U004** (Fig 7). The upper part of the elevation is divided into two parts, north-west (Plate 22) and south-east (Plate 23). They both contain a single lancet window, of which the south-east part is glazed with a one-over-one timber sliding sash window and the north-western side has a side opening casement. The north-western side has a steel ladder which gives access to the roof of the main part of the building. Most of the north-western side has been re-pointed with cement mortar and has a plastic down spout.
- 4.4.11 The south-west elevation of the extension to the Museum is divided in two parts by the main castle curtain wall (Plates 24-26). The north-west side has four windows,
-

---

two on the first floor and two at ground floor level. Those on the first floor are lancet windows similar in appearance to the others already described on the main part of the Museum's south-west elevation, and have one-over-one hornless sliding sashes; the stone surrounds exhibit furrow tool marks. The windows at ground floor level are stone-mullioned, that on the left having 12-light glazing, while that on the right is glazed with a six-over-six sliding sash window with horns. Both have bars set into the lintel and sill; the surround is stone and the sill projects slightly.

- 4.4.12 To the right of the window is a doorway which has a tool-marked sandstone surround and a vertical plank door. Two pintles in the jamb suggest that the current door is either a replacement of an earlier one or suggests that an additional outer door was present. Some rebuilding has taken place to the left of the aperture, and a low ashlar wall is located adjacent to the doorway.
- 4.4.13 At the south-east end of the sunken walkway (which was once flagged), where the curtain wall meets the south-west elevation, a blocked projecting doorway, with a substantial tooled sandstone surround, is visible; this once allowed passage through the curtain wall to the south-east side of the elevation (Plate 25). It is also visible on the other side of the wall together with sandstone steps. A further blocked doorway is present in the south-eastern part of the south-west-facing elevation which once allowed access to the ground floor (Plate 27). Both of these are blocked with brick and have been partially rendered. The doorway in the curtain wall has a sandstone sill and the doorway in the south-west elevation has a sandstone surround. Above this door, some brick rebuilding is visible which was probably an indication of a flue for the heating of the Orangery (Plate 28). A sloping roof scar is also evident.
- 4.4.14 There are three doorways on the south-west side of the sunken walkway which probably led to either storage areas or lavatories (Plate 28). These rooms are set into the garden area to the south-west of the building. The south-west retaining wall of the sunken walkway is comprised of random-coursed sandstone rubble with sandstone coping stones topped with steel railings. The walkway continues around the corner to the south-west elevation where a doorway, with sandstone surround, allows access and egress. Stone steps allow access and egress to the garden at the south-west side of the building (Plate 29).
- 4.4.15 **North-West Elevation:** the north-west elevation of the building (Fig 8) comprises three distinct parts, the north-eastern most of which projects and is part of the front 'wing' (Plate 4). The most immediately noticeable feature of this elevation is the obvious difference in fabric at the south-west end which is limestone (of identical appearance to the Sound Archive). For the most part, the elevation is constructed from random sandstone rubble of similar appearance to the north-east elevation. An irregular vertical join is evident (Plate 5) in the centre of the elevation and this would appear to reflect a former elevation edge, which has subsequently lost its quoins. The implication is that the south-west end of the building was a later addition. Each corner of the building exhibits sandstone quoins, and those at the south-west end were seemingly reused, and may perhaps correspond with those removed from the centre part of the wall.
- 4.4.16 The fenestration in the south-western part of the elevation contains multi-light sash frames set within two centred arched (lancet) sandstone surrounds (Plate 4). Two of these, on the first floor, are wider than the rest and have a variant of four-centred arched heads. The other windows are very similar in appearance to those in other parts of the building except for two on the ground floor in the north-eastern part of
-

---

the elevation which have round heads. The window surrounds on the north-east side are slightly more weathered than those on the south-west side, apparently reflecting that this was the older part of the structure. Between these, a section of rebuilt masonry indicates the outline of a blocked former doorway (Plate 30). There is a single doorway which is set within the south-western, later part of the elevation and has a surround similar to the windows. A 'gothick' fanlight is present over the door, which is of plank construction and relatively recent (Plate 5).

- 4.4.17 A crenelated parapet of identical appearance to that on the other parts of the building is evident and again is of later build than the underlying structure. There are two ashlar chimneys with diagonally set stacks without pots, and the rainwater goods are plastic.

#### 4.5 MUSEUM INTERIOR - GROUND FLOOR

- 4.5.1 *Internal Details:* the Museum is divided by solid cross-walls the layouts of which differ slightly on each floor (Figs 3-6). It is apparent that some modifications to the layout have been made and some modern partition walls have been inserted. Room numbers follow those illustrated on the supplied architect's plans and each room will be described in number sequence as far as is practicable. All the fixtures and fittings within each room (ie heating and lighting provision) are of late twentieth century unless otherwise indicated.
- 4.5.2 *Room E001 and E004:* upon entering the Museum via the main entrance lobby, which is plain plastered and has modern double doors, the first room encountered is **Room E001** which contains the main staircase allowing access to the upper floors (Plate 31). The staircase is decorative with alternately fluted balusters and tread ends decorated with carved flowers and foliate scrolls; panels are present on the soffits. A separate staircase allows access to the basement. **Rooms E002, E004, L006** (first floor) and **E012** are directly accessible from this room. **Rooms E003, E005 and E011** are accessible from **Room E004**.
- 4.5.3 Each wall in the room has decorative plaster moulding panels (Plate 32), and simple moulded cornices, together with plain corbels; the ceiling is *c* 2.98m (9 <sup>3</sup>/<sub>4</sub> feet) high. The doors (except those allowing access into **Rooms E004 and E002**) are six-panelled and have wide moulded architraves with deep plinth blocks. Deep architraves are present and the floor has carpet tiles, laid on decorative geometric encaustic tiles of late Victorian appearance with a guilloche border (these are fully exposed in **Room E004**). There is a single window with deep sill in the north-east wall.
- 4.5.4 *Room E002:* this room is located at the north-east corner of the building within the 'South-East Tower' (Fig 4). The room was being used as a store room at the time of the survey and iron shelving, of nineteenth century appearance, is attached to the walls (Plates 34 and 35). Each shelf has a perforated guilloche pattern similar to the border of the tiles in **Room E004**. The walls are all plain plastered and painted white. The ceiling (*c* 2.98m high) is constructed of massive sandstone slabs supported upon three flush beams, which are of cast iron manufacture; these are in turn supported upon stone corbels with Cyma recta moulding.
- 4.5.5 There are two window apertures in the south-east wall, which are blocked with brick laid in stretcher bond (Plate 34), they both have semi-circular arched splayed reveals with angle-beading and low timber sills. Externally, both of these apertures
-

---

retain their windows (Plate 13). A recess on the opposite wall is of similar style but has a segmental arch and no sill. To the left of this is a further, very small, partially obscured flat headed recess which has a timber sill and angle-beading. This corresponds with a blocked window visible externally (Plate 16; Fig 4) which formerly lit this room. There is a similar recess at the diametrically opposite corner of the room which appears not to have been a former window, as there are no external indications of an aperture.

- 4.5.6 The doorway to this room consists of two sets of heavy iron doors, of which the internal one is a double door (Plate 35). The external door, facing into **Room E001**, is thick with large strap hinges and has a substantial locking mechanism with a large key. The internal doors are of single thickness iron plate with two handles on the internal side and knobs on the outside. When open, the doors, and the knobs, fit into a carefully designed recess within each of the jambs. Each internal door has a substantial bolt top and bottom. The interior door surround is of sandstone construction. This was evidently a secure room intended to also be fireproof; it was probably intended to store valuable items and documents.
- 4.5.7 **Room E003**: this room is located at the end of the corridor (**Room E004**) and was last used as an administration office. It is plain plastered and has few decorative details; the skirting boards are similar to those in **Room E001** and incorporate simple mouldings. The floor is laid down to carpet over timber boards. The ceiling is plain and of the same height as the other rooms thus far described; a single boxed-in beam crosses the room. The door is six panelled and has a simple wide architrave with plinth blocks, and is set within a panelled reveal. There is a built-in dresser/cupboard on the north-west wall which is painted and grained and of nineteenth century appearance. A distinctive fireplace is set into the south-eastern wall; it is made from fossiliferous stone and has a gothic revival style (Plate 36) incorporating carved gothic detailing. The opening has been boarded over and there is no chimney breast; twentieth century radiators now provide the heating and all the light fittings are modern.
- 4.5.8 The fenestration in this room consists of two walk-in windows with panelled splayed reveals, containing shutters and the architraves exhibit similar moulding to that on the doorway. Modern chipboard shutters have been installed and the glazing is modern with ventilation fittings. The frames have pointed arches and are modern.
- 4.5.9 **Room E005**: this is a large room accessible from **Rooms E004, E006** and **E011** and was latterly used as an exhibition room (Fig 4). The room contains large display cabinets and large photographic display boards, which substantially obscured the fabric (Plate 37). The walls are all plain plastered and there is a skirting board of identical appearance to that in **Room E004**. The floor is laid down to carpet over timber boards and the ceiling is the same height as those already described; the ceiling is divided into three by two beams each of which exhibit hollow chamfering with run-out stops. A decorative cornice with billets is visible in each part of the ceiling (Plate 38).
- 4.5.10 The north-west wall of the room contains a depressed arch aperture which allows access to and from **Room E011** (Fig 4). This may be a part of the original fabric of the building and certainly is similar to one between **Rooms E011** and **E012**; however, there is a blocked doorway to the right of the opening which may belong to an earlier phase. Opposite this aperture into E011 are two columns which support three semi-circular arches with projecting decorative 'key stones', forming a short
-

---

arcade; two pilaster columns are present at either end. This is an extension of the corridor **Room E004** and as such provided access throughout the length of the building in its original build (*Section 4.5.3*)

- 4.5.11 The fenestration in this room was largely hidden by museum fixtures and display boards but the western window became visible when stripping work commenced. It comprises a walk-in square reveal with panelled soffit and shutters; it has four-lights and was sealed shut. It is evident that, judging from external inspection, the other window is of the same design; these windows may once have allowed access and egress to the balcony. It is probable that a fireplace exists or existed in-between the windows.
- 4.5.12 **Room E006**: the following rooms, **Rooms E006, E007, E008, E009** and **E010** are located within the south-west extension (*Sections 5.2.6* and *5.2.7*). Access to **Room E006** is available from **Rooms E005, E007** and **E010a** (Plate 39; Fig 4). The doorway allowing access to and from **Room E005** appears to have been inserted recently, as the original access was via a blocked door, now used as a cupboard located in the northern corner of the room. Another cupboard is located to the left of the north-western wall, and appears to be contemporary with the other internal doorways already discussed (Plate 39), having decorative moulding and plinth blocks. It has a splay and was evidently . The other doorway, allowing access into **Room E007**, is modern and plain. The skirting boards are less decorative than those in the rooms previously described.
- 4.5.13 The room is generally of plain appearance and all the walls are plastered and painted. A wooden partition has been fixed to the south-east wall obscuring the windows, although external observation revealed that they were of lancet type with one-over-one sliding sash frames. There are three boxed-in beams supporting the ceiling which lie on an north-east/south-west axis. To the north-west of these, and fixed into the ceiling, are five wrought iron hooks, which have no apparent current usage.
- 4.5.14 **Room E007**: this room is accessible from **Rooms E008** and **E006** and a sealed doorway, of similar appearance to those in **Room E006**, once allowed access to **Room E010b**. The room was latterly used as a display area and various modern display stands are still present. It is of plain appearance with plastered walls and ceiling which incorporated two north-east/south-west boxed-in beams (Fig 4). The floor is laid down to carpet apparently over stone. There are no skirting boards just a stone plinth at the base of all the walls. There are two walk-in lancet windows with splayed reveals set within the north-west wall, one of which has a one-over-one sliding sash; the other has a single pane with a ventilation fixture.
- 4.5.15 The most obvious feature of this room is the fireplace set within the south-west wall (within a shallow chimney breast), which appears to be part of the original fabric and was obviously used a surround for a kitchen range which has subsequently been removed. The surround is stone (painted) and has chamfered corners with straight cut stops (Plate 40). The cornice is simply moulded and three metal plates/brackets have been fitted which are of unknown use but probably supported hooks or other implements. The opening has been partially rebuilt (using some modern brick), probably to house a range-type stove.
- 4.5.16 **Room E008**: dominating this room are the large stone sink and fireplace indicating that this room was once used a kitchen (Plates 41 and 42), otherwise the room is
-

---

quite plain, with plastered walls and ceiling. There are two north-east/south-west beams supporting the ceiling, of which one is boxed-in and the other is not, exhibiting chamfered edges. This beam, at its south-western end, coincides with a stone-mullion which has similar chamfering with run-out stops. Where the two meet the beam has been cut away (Plate 43), and the top part of the mullion has been modified slightly.

- 4.5.17 The window, which is mullioned (*Section 4.4.11*) with a square reveal, contains a six-over-six sliding sash frame (horns externally) with sash ovolo glazing bars and a twelve-light plain frame. Below each is a large sandstone slab, and below this is the sink (Plate 43). It is a shallow, large stone affair with two substantial drain holes and is set into the wall. A notch cut into the left side of the sink, together with a scar in the adjacent wall, suggest that a drainer or small work surface once existed here.
- 4.5.18 The north-west wall of this room contains two asymmetrical openings, which span the full length of the room (Plate 42). The stone surround is finely worked, exhibiting vertical and horizontal furrow tool-marks, and is topped by a plain moulded cornice. Unfortunately, both openings were blocked at the time of survey so a detailed picture of the nature of the fireplaces could not be determined. The floor of this room is laid down to carpet over stone and there is a similar stone plinth to that in **Room E007**.
- 4.5.19 There are two doorways enabling access to **Rooms E007** and **E010b**, both of which have simple architraves and reveals. There is also access to the sunken walkway at the rear of the building through a doorway, which has a plain sandstone surround.
- 4.5.20 **Room E009**: this room can only be accessed via **Room E010b** and is one of the smallest rooms on this floor (Fig 4). The room is very plain, and the plaster walls are somewhat more rough in appearance than of the other rooms. The floor is identical to that in **Room E010** and the ceiling is plain. The fenestration consists of a wide timber-mullioned window with three lancet nine-over-six sliding sash frames; the reveal is splayed and there is a stone sill.
- 4.5.21 Scars across the floor, wall and window frame suggest that the room was once divided down the middle; the two doorways adding to this supposition. Both of the doorways are identical each having simple moulded architraves with plinth blocks (internally they are plain). Each doorway has a transom light; the western door has been partially boarded over and contains a small window.
- 4.5.22 **Room E010**: this room comprises two halves, **Room 010a** and **Room 010b**, which are divided by a partition wall (Fig 4). It forms an 'L-shaped' corridor with external access and egress (to the north-west side of the building) and which affords access to **Rooms E007, E008, E009, and E011**. A flight of stairs allows access to the first floor (**Room L001**), and a second flight of steps formerly allowed access to the basement, but this is now blocked with cinder blocks. Between **Rooms E006** and **E010b** was a blocked window, with an outward splay into **Room E006**, which may be an indication that this was formerly an external wall. A blocked doorway formerly afforded access into **Room E005**, although it may simply be a cupboard. There are two entrances (one boarded) into **Room E009**, which may have formerly been two smaller rooms (*Section 4.5.21*).
- 4.5.23 All the doors have six panels and all have similar moulded architraves (with plinth blocks) to those in the rooms already described. All the walls and ceiling are plain
-

- 
- plastered, and the skirting boards are similar to that in **Room E006**. The dividing wall between the two areas is plasterboard. The floor is laid down to substantial sandstone flags. A boxed in ventilation shaft is visible and various pipes are affixed to the ceiling; there is a north-east/south-west beam visible in **Room E010b** into which three wrought iron hooks are fixed.
- 4.5.24 The staircase, which allows access to the first floor, is open-well with landings and plain balustrade with turned newels (Plate 44). The tread ends are decorated with simple scrolls and a panelled cupboard is present below the stairs. A redundant gas fitting is located on the wall at the bottom of the stairs. There is a lancet window at half-landing level. At the north-west end of the room a doorway with a 'gothic' fanlight leads to the exterior of the building (Plate 44).
- 4.5.25 **Room E011**: the doorway into this room from **Room E010a** has a curving splayed reveal set within the wall which coincides with vertical joins in the south-east and north-west elevations (Fig 4). It has a semi-circular arched fan light and seems to have once been an external doorway. It is probable that this wall formed the south-western external elevation of the original construction phase. The room is quite large and was last used as museum exhibition space. There is open access to **Rooms E005** and **E012** via two wide arched openings (Plates 45 and 46). The room is generally plain in appearance and has plain plaster walls. The skirting boards are identical to those described for **Rooms E001** and **E004**, and the floor is laid down to carpet over stone.
- 4.5.26 The most obvious feature is the ceiling, which is divided by five cross-beams (four south-east/north-west beams and one north-east/south-west) that are all plastered. These arguably betray the former layout of the room, which consisted of two smaller rooms and a corridor (Fig 4). The latter once ran the length of the room to the former external door now allowing access to **Room E010a**. A north-east / south-west beam, supported by a square column, provides some evidence for this although other evidence suggests it is a later addition. The basis for this supposition is that the north-east/south-west beam appears to bisect decorative cornices (identical to those in **Room E012**) which are present on the south-east/north-west beams. Of the south-east/north-west cross beams, the flanking examples exhibit traces of a recessed panel in the soffit similar to those in **Room E012** indicating that these were not cross walls. Clearly, various phases of modifications have been carried out and the situation is not clear. There was also a possible blocked door in the north-west elevation (Plate 30).
- 4.5.27 A small room housing the alarm control system is located at the north-east end of the former corridor and has been created partly by the erection of plasterboard partition walls. Within this room a beam with decorative cornice identical to that described above is visible, indicating that this room was originally separate from **Room E011** and was part of a corridor that extended to the back stairs (**Room E010a**).
- 4.5.28 The fenestration of **Room E011** consists of a boarded window which was similar to the other window that is still visible. This has a splayed reveal with panelled shutters and soffit, together with a moulded architrave and cupboard below the sill. The window is a one-over-one sliding sash affair (without horns) and, contrary to most of the other fenestration in the building, has a semicircular head.
-



- 
- 4.5.29 **Room E012**: this room was apparently last used as the Museum shop and is one of the most decorative rooms in the building (Plate 47). The most obvious feature is the ceiling which is divided into three by two south-east / north-west beams (Plate 48). Each sunken panel or 'coffer' exhibits a plain run cornice with a decorative fleuron at each corner (Plate 49), which collectively are identical to those observed in **Room E011**. Each beam has a recessed panel running the full length of the soffit and is supported by a single square column which exhibits chamfering with run-out stops, and these appear to be later additions. A decorative plaster frieze surrounds the room which consists of alternate small festoon-like groups of flowers and fruit suspended from scrolls (Plate 50).
- 4.5.30 The other notable feature of this room is the marble fireplace located at the south-east end of the room; it has a similar surround to that located in **Room E003** although it is not quite as decorative and is comprised of two types of marble with lighter coloured 'gothic' panels. There is no grate or insert but the reveal has canted cheeks alluding to the type of grate it once contained. The hearth tiles are present though, which are of encaustic manufacture (of nineteenth century appearance) with yellow fleurons (very similar to those on the ceiling) alternately set within black circles on a red background (Plate 51). Most of the tiles are damaged and some were concealed behind carpet, which covers the rest of the room and below which is a stone floor.
- 4.5.31 Attached to the wall either side of the fireplace are two rotary handles which were presumably used for adjusting ventilation or dampers within the chimney flue or may indeed be servant bells; the handle on the right has a decorative cap.
- 4.5.32 The fenestration comprises two walk-in windows located on the north-east wall, both of which have splayed reveals (Fig 4). They both have panelled shutters and soffits together with a moulded architrave with plinth blocks; the windows are mullioned one-over-one sliding sashes (without horns).

## 4.6 MUSEUM INTERIOR - FIRST FLOOR

- 4.6.1 **Room L006**: all the rooms on the second floor of the Museum building are prefixed 'L' and this room forms the landing area leading via the main stairs from **Room E001** (Fig 5). The staircase contains identical detailing to that described in **Room E001** and the soffit is panelled. The floor is laid down to carpet and the ceiling is plain with plain-run cornice moulding; dentils are present on the cornice. The room has two plaster wall panels which are identical to those in **Room E001**. There are two windows located in the north-east wall, both of which have semi-circular arched heads and splayed reveals; they each have plain sills and one-over-one sliding sash window frames within a two-centred 'gothic' arch. The staircase continues up to the second floor (**Room U009**) and access to **Rooms L002, L005 and L007** extends from the room. The doorway leading into **Room L002** is modern and these rooms were once contiguous.
- 4.6.2 **Room L007**: this room is situated directly above **Room E002**, within the South-East tower, and has the same layout (Figs 4 and 5). It is a cluttered, fairly plain room and was last used as a small private office; it is reached via a short flight of steps from **Room L006**. There is a simple picture rail and all the walls and ceiling are of plain plastered appearance. A single north-east / south-west beam supports
-

---

the ceiling, which is itself supported upon plain stone corbels (Plate 53). The floor is laid down to carpet over timber boards.

- 4.6.3 The most obvious feature is the large built-in dresser at the south-west end of the room, which appears to be of nineteenth-century character. There is a very plain painted stone fireplace (no chimney breast present) set within the east wall, which has been boarded over. Above, and either side of, the fireplace are two plain pateras, which formerly housed gas lighting fittings.
- 4.6.4 The fenestration in this room consists of two window apertures which have matchboarded splayed reveals and wide architraves. Each has a plain timber sill and the frames consist of one-over-one sliding sashes with a two-centred 'gothic' arch (Plate 53).
- 4.6.5 **Room L005:** this room was last used as a display area and contains numerous display boards, which partly obstruct the walls. Most of the pertinent detail is still visible, however, and it is clear that the room was elaborately decorated, the most obvious feature being the decorative plasterwork on the ceiling (Plates 54 and 55). The layout of the ceiling is identical to that in **Room E012** with three 'coffers' divided by two south-east / north-west beams; each 'coffer' exhibits decorative panels of plain roll moulding with regular 'tags' and decorative pointed scrolls. A plain-run cornice with egg and dart moulding is also present, some of which appears to have been removed. Unlike those in **Room E012**, the soffits of the beams are plain and there are no supporting columns.
- 4.6.6 The skirting boards are identical to those in **Room E012** and the fenestration is identical, the only difference being the apparent removal of the shutters and panelling in the reveals. The door to **Room L006** is a six-panelled affair and is identical to those examples still present on the ground floor; the door reveal has a segmental arched head and is plain. A further doorway allows access to **Room L004**, and appears to be contemporary with the other doorway in the room. There is a fireplace set within the south-east wall, which at the time of survey, was obscured by display boards.
- 4.6.7 **Room L002:** this room forms the main corridor on the first floor and provides access to all the first floor rooms (except **L007 and L011**) (Fig 5). It is quite plain and all the doorways off it have six-panelled doors, panelled reveals and architraves with deep plinth blocks (Plate 55). The floor is laid down to carpet over timber boards and the skirting boards are identical to those in **Room L005**. The ceiling is mainly plain except for the north-eastern end which has a plain-run cornice, which may have extended across the rest of the ceiling, but has now been removed.
- 4.6.8 At the south-west end of the corridor a second staircase (**Room L001**) affords access to both the ground and second floors. This end of the corridor is quite plain with low skirtings and plain modern doorways; a doorway with a semi-circular arched head and fan-light, allows access to **Room L012**.
- 4.6.9 **Room L004:** access to this room is available from the main corridor (**Room L002**) and **Room L005** (Fig 5); it was last used as a display room. Display panels obscure almost all of the fabric of the room, which for the most part was plain and without embellishment. There is a plain picture rail and a single south-east / north-west beam supporting the ceiling.
- 4.6.10 Two window apertures are present in the north-west wall, one of which is hidden by display boards. An architrave is still visible, however, and this is identical to that
-

---

on the other window. This has a walk-in splayed reveal and the window frame is boarded over but externally can be seen to be a one-over-one sliding sash (Plate 4). Two modern shelves are present. The wall dividing this room from **Room L003** is a partition wall of lath and plaster construction and together these rooms may have constituted a larger space.

- 4.6.11 **Room L003**: this room is entirely obscured by display boards and cabinets. The floor is laid down to carpet and the ceiling is plain plastered. A single window exists in the north-west wall (Fig 5), which, from external observation (Plate 4) was evidently similar to those in **Room L004**. The doorway allowing access from **Room L002** is identical to the others on this floor, while a second (blocked) doorway is visible beneath the display boards in the north-east wall. A rotary handle, identical to those in **Room E012** (*Section 5.4.54*), is located next to the main doorway.
- 4.6.12 **Room L001**: this room comprises the back staircase, which allows access to all the floors in the building (Figs 4, 5 and 6). It is generally very plain in appearance and lacks any form of ostentatious decoration. The stairs are identical to those observed in **Room E010a** (*Section 4.5.22*; Plate 44). The most noteworthy feature is a 15-over-10 sliding sash window (without horns) at half-landing level, the top sash having a two-centred arched head; the sill is sloping and the reveal is slightly splayed.
- 4.6.13 The doorway leading to **Room L002** has a transom light and a modern fire door, which is set within a possible partition wall (Fig 5). A further doorway, which has an architrave similar in style to the others on this floor, allows access to toilets which are of twentieth century appearance. A window identical to that in **Room L001** is present and these toilets were evidently formerly a single room.
- 4.6.14 **Room L012**: this room is quite large and occupies (together with the adjacent **Room L011**) the top floor of the rear extension. It is open up to the roof, which is of hipped construction with exposed hip rafters and purlins. The roof lies on a south-east / north-west axis, which is different from the main part of the building which follows a north-east/south-west axis. In common with the other rooms on this floor, most of the fabric is obscured by display cabinets; however, all the walls are of solid construction and are plain plastered. The floor was laid down to carpet over timber boards.
- 4.6.15 There are three boarded-over windows which are visible externally and are of lancet type (Plate 24). The window in the north-west wall has a six-over-six sliding sash while those on the south-west wall have one-over-one sashes. No trace of the fenestration is visible internally. The doorway leading to **Room L002** has a semi-circular arched head with fan light and six-panelled door (of different style to the others already described).
- 4.6.16 **Room L011**: access to this room is available via **Rooms L012** and **L010** and it was last apparently used as an educational room. It is a plain, square room and the main interest is the fenestration which is situated on the south-east wall, consisting of two walk-in windows with panelled splayed reveals and panelled sills. The frames are one-over-one sliding sashes which are identical to those inspected in **Rooms L006** and **L007** (*Sections 4.6.1* and *4.6.2*). The doorway leading into **Room L012** has a moulded architrave with plinth blocks similar to those already described; however, there is a modern internal extension made of wood or plasterboard which
-

---

forms the surround for a modern door. The floor is laid down to carpet over timber boards with low skirtings.

- 4.6.17 **Rooms L009 and L010:** these rooms are interconnected and were formerly divided by an external wall; Room L010 forming part of a later build; however, the dividing wall has been removed creating a single, long room. The two former rooms are here described together as they form a contiguous exhibition space, and much of the fabric of these rooms is obscured by extensive displays (Plate 56). The fenestration is visible and is identical to that already described (Fig 5), as are the doorways (Plate 55). A plain run cornice is also visible.
- 4.6.18 **Room L008:** this room is plain and quite dark as the two windows in the south-east wall have been boarded over. External inspection reveals these to be of similar appearance to those already described and both have one-over-one sliding sash frames. Part of the architrave is visible as are the plinth blocks. The room was last used as a display area and is painted dark green. All the walls are plain and the floor is laid down to carpet over timber boards. A picture rail is visible and a single south-east/north-west boxed beam supports the ceiling. There is a fireplace set within the north-east wall, which has a plain stone surround and the opening has been boarded.

#### 4.7 MUSEUM INTERIOR - SECOND FLOOR

- 4.7.1 **Introduction:** all the rooms on the second floor are prefixed with the letter 'U' and the layout is similar to the first floor, the main difference being that there are fewer rooms on this floor and they are all of very austere and plain appearance and all appear to have been used for storage. All the doors on the floor are of four-panelled design of nineteenth century appearance with plain architraves.
- 4.7.2 **Room U009:** this is the continuation of the main staircase from **Room L006** and all the features of the staircase are as described in *Section 4.5.2*. The room is almost identical to **Room L006** but is without the plaster wall panels or indeed any decoration (except the staircase). There are two windows located on the north-east wall which have plain plastered splayed surrounds and identical sash windows (although not as tall) to those in the room below. Access is afforded from here to **Rooms U001, U008 and U010**.
- 4.7.3 **Room U001:** this room is located directly above **Room L007**, forming the upper floor of the South-East Tower, and is of the same dimensions (Figs 5 and 6). It is of very plain appearance, has no decorative elements and the fenestration is identical to that for **Room U009**. A small hatch in the ceiling permitted limited inspection above which reveals that the current ceiling (plasterboard, 2.64m high) has been inserted and the original ceiling was of lath and plaster and was 3.15m high.
- 4.7.4 **Room U008:** in common with all the rooms on this floor, this room is very plain and lacks any decorative elements (Plate 57). The carpeted floor appears to have been raised, as there is a step up upon entering the room. The fenestration consists of two walk-in apertures with slightly splayed reveals on the north-east wall and the frames are identical to those in **Room L005** although they are not as deep. There is a boarded up fireplace located on the south-east wall.
- 4.7.5 **Room U010:** this is the central corridor which allows access to all the rooms on the second floor (Fig 6). Again it is of very plain appearance with plain walls, ceiling
-

---

and carpeted floor over timber boards. There is a doorway at the south-western end with a semicircular arched head which allows access to the back staircase (**Rooms U005** and **U004**). Modern heating pipes run down the length of the ceiling.

- 4.7.6 **Room U007**: this is a small square room of plain appearance, the only distinguishing features being the fenestration and the sandstone fireplace in the north-west wall. The fenestration is identical to that in **Room U009**. The fireplace is quite plain and the opening is boarded. It appears to be of similar proportions and style to those within **Rooms L007** and **L008** (Plate 58).
- 4.7.7 **Room U006**: this room is smaller but identical in general appearance to **Room U007**. The single window is similar to those of **Room U007**, but is slightly more ornate (although still of austere appearance) (Plate 59). It has a fairly substantial hearth and the opening is boarded. The wall dividing this room from **Room U007** is a narrow partition and is a later insertion (Fig 6).
- 4.7.8 **Room U005**: access to all the lower floors is available via this room which is plain and without embellishment. The staircase has plain balusters and there is a single window on the south-east wall which is identical to the others already described. A gas fitting is present on the south-west wall just above the staircase, which has a decorated patera. A modern fire door has been fitted between this room and **Room U0004** which is set within a partition wall.
- 4.7.9 **Room U004**: this room occupies the rear of the second floor and has been re-plastered recently. There are three windows which are similar in appearance to those already described; one of these (in the south-west wall) has been modified to allow access to the roof of the south-western extension (Plates 22 and 23). A modern sink unit and work surface are present.
- 4.7.10 **Room U003**: this is a large plain room with two walk-in windows of slightly different sizes but essentially the same as the others on this floor; there is a further blocked window in the south-east wall. The other feature worthy of mention is a small length of hip rafter visible at the south-west corner of the ceiling.
- 4.7.11 **Room U002**: this room is essentially similar to **Rooms U006** and **U007** and contains a small sandstone fireplace of similar appearance to that in **Room U007**. There is a loft hatch which allows limited access to the roof space, which, from limited inspection, appears to have been recently re-covered (Plate 61) and has a breathable textile membrane. All the rafters appear to be recent replacements but the ridge purlin is probably earlier. Part of a communication system of pulleys is visible which consists of wires and levers (Plate 62). Some brick and stone fabric is also visible.

#### 4.8 MUSEUM INTERIOR - BASEMENT

- 4.8.1 The basement is divided into four rooms in two areas, which are currently accessible via two separate entrances (Fig 3). The basement only covers part of the ground plan of the building and there is no evidence to suggest that there is a basement across the rest (Fig 3). The main access in to the basement is via a doorway located beneath the stairs in **Room E001**.
- 4.8.2 **Room B001**: a flight of stone steps (half turn) exhibiting vertical furrow tool marks and an iron hand rail, leads down to an irregularly-shaped barrel-vaulted room (Fig 3; Plate 63), which is plain plastered and whitewashed and has a flagstone floor.
-

---

There are two lancet windows with splayed reveals located in the south-east wall which have been partially blocked externally by later stairs and are visible from the outside (Plate 18). Also within this room is a substantial stone bench (exhibiting furrow tool marks) with storage below.

- 4.8.3 **Room B002:** to the south-west of **Room B001**, through a plain doorway with a concrete lintel, is a further room (**Room B002**) (Fig 3), which is also barrel-vaulted, and has been divided into two areas by the insertion of a brick (stretcher bond) dividing wall at the north-west side. This was done obviously in order to create a small strong room with storage shelving which is of substantial construction with sandstone shelves (also with furrow tool marks) (Plate 64). The south-east side of the room also has substantial shelving which appears to belong to an earlier phase. A further lancet window is visible extending through the considerable thickness of the south-east wall. A possible blocked doorway extended through the north-western part of the south-west wall that divides this from **Room B003**.
- 4.8.4 **Room B003:** further to south-west of **Room B002** (through a similar doorway) is another much larger room (**Room B003**) which is also barrel-vaulted and has a flagged floor. This room is quite plain and has a blocked window (cinder block) in the south-east wall which has a splayed reveal and is visible externally. A large diameter steel flue passes through the room and exits through the window (this originates from the adjacent room). A modern door once allowed access to the rooms further to the south-west (Fig 3) but this could not be opened at the time of the survey. A possible coal chute is located at the south-west end of the room.
- 4.8.5 **Room B004:** access to the south-westernmost rooms of the basement is only available externally from the north-west elevation (*Section 5.4.5* Plate 20), but was once accessed internally from **Room B003** and a corridor leads to a flight of worn stone steps which once allowed access up to **Room E010b**, but which is now blocked with cinder blocks. A short barrel-vaulted corridor leads to a plant room (**B004**), which contains a large modern boiler (the source of the steel flue). The room is again barrel-vaulted and has a flagged floor.

#### 4.9 SOUND ARCHIVE AND COURT HOUSE LAYOUT AND FABRIC

- 4.9.1 **Layout:** the Court House and Sound Archive buildings are both laid out over two storeys and are located at the south end of the range which occupies the west side of the castle ward (Fig 2). They are aligned on a general north/south axis in a 'dog-leg' fashion and are connected on both floors by a short corridor. The main access (for both buildings) is on the east elevation of the Sound Archive.
- 4.9.2 The Sound Archive building measures some 13.3m by 9.8m at the widest points while the Court House, which is the southern end of a range of buildings is some 7.6m wide.
- 4.9.3 **The Sound Archive, External Fabric:** the walls of this building are almost wholly constructed from random un-coursed squared rock-faced limestone with rock-faced limestone quoins (Plate 10). The only exception is the north-west (rear) elevation, which is constructed from random un-coursed sandstone rubble. All the mortar appears to be cement.
- 4.9.4 All the other external features of this building, such as the window surrounds, kneelers, gutters, rear jetty corbels, front porch and all the other mouldings, are of a fine-grained sandstone. There are two chimneys, which are of sandstone ashlar construction and have yellow terracotta pots. The roof covering is flagstone with a
-

---

sandstone ridge. The windows are all leaded with diagonal comes and have wrought iron and steel bars.

- 4.9.5 ***The Sound Archive, Internal Fabric:*** most of the internal walls are solid and plastered but there are some partition walls that are mainly of plasterboard construction. All the floors on the ground floor are flagged, while those on the first floor are of timber construction. All of the internal doors are of timber and the staircase is of timber construction.
- 4.9.6 ***The Court House and Linking Corridor, External Fabric:*** this building is constructed of random un-coursed, squared, well-finished limestone without quoins. The lower part of the south-west elevation (Elevation 4) and south-east elevation of the linking corridor (Elevation 3) are constructed from random un-coursed sandstone rubblestone (Plate 11). The lower part of the north-west elevation is constructed from a mixed fabric of random sandstone and limestone (Plate 12). All the other features, such as the mouldings, window surrounds and corbels, are of similar sandstone to those within the Sound Archive building. The flagstone roof is hipped with lead ridges and has a limestone parapet with sandstone coping stones. The roof of the linking corridor is flagged with a sandstone ridge.
- 4.9.7 ***The Court House, Internal Fabric:*** the upper floor of the Court House and linking corridor has a tiled floor with iron grilles and tiled walls. The ground floor of the linking corridor has a concrete floor, whilst the ground floor of the Court House has flagged and cobbled floors. It is divided by both solid and plasterboard walls; evidence of brick walling is also visible.

#### 4.10 THE SOUND ARCHIVE - EXTERIOR

- 4.10.1 ***East-Facing Elevation:*** as outlined above, the main entrance for both buildings is located on the east elevation of the Sound Archive building (Plate 66) and is set within a projecting porch with crenelations. It is of ashlar construction, has a plain entablature with projecting architrave and plain frieze, and is set within a moulded reveal with an eared hoodmoulding. A flat two-centred arch, with recessed spandrels, crowns the reveal and the door is a substantial planked affair with flamboyant strap hinges; a chamfered plinth is also present. Given the distinct ashlar masonry with respect to the rest of the wall, it is apparent that this doorway was a later addition.
- 4.10.2 The remainder of the east-facing elevation is constructed from un-coursed squared limestone and has large rock-faced sandstone quoins (Plate 10). It is of identical appearance to the south end of the north-west-facing elevation of the Museum (*Section 4.4.15*; Plates 4 and 5) and was probably contemporary. There is an ogee-shaped, sandstone gutter with projecting moulded kneelers. The base of the elevation is obscured by foliage.
- 4.10.3 The fenestration consists of four stone-mullioned windows, each glazed with iron-framed casement windows with lozenge- and diamond-shaped comes. The largest window, on the ground floor, has stained glass which is described in *Section 4.12.4*. Each slightly projecting surround is constructed from sandstone and has cavetto-moulded mullions and lugged sills and lintels. The ground floor windows also have lugged jambs. The large ground floor window has transomes and a hood moulding,
-

---

whereas the others are without the hood moulding. The ground floor windows are barred and it is probable that the windows are of differing phases.

- 4.10.4 ***South-Facing Elevation:*** the south-facing gable elevation of the Sound Archive (Fig 12; Plate 67) is constructed in the same fashion as the east elevation and contains two mullioned windows of similar, but not identical, style (as they lack the lugs) to those already described. Both have glazing that is identical to that previously described and both windows are barred; the ground floor window is of modern appearance and the upper window has a saddle bar. The verge is flush with a sandstone coping and sandstone kneelers are present at both sides. The roof slope is asymmetrical and a mixed fabric chimney stack straddles the ridge. This is rather plain and has a simple projecting cavetto-moulded oversailing course.
- 4.10.5 It is apparent that some rebuilding has taken place specifically in the region of the windows, and the ground floor window surround, which is slightly different to that of the upper floor, may have been replaced. More rebuilding has taken place adjacent to the curtain wall which butts up to the west side of the elevation (Plate 67), and may reflect that this wall has been rebuilt; the western extremity of the elevation was not visible due to trees. A walkway runs along the base of the elevation.
- 4.10.6 ***West-Facing Elevation:*** the west-facing elevation of the Sound Archive building is, for the most part, obscured by trees and, owing to the steep slope, detailed inspection was difficult and photography almost impossible. The base of the elevation could not be inspected. This is a two part elevation with the upper, north side forming the gablet of the east/west roof section (Plate 12; Fig 14).
- 4.10.7 The main part of the elevation is of random rubblestone construction comprising mixed limestone and sandstone fabric with smeared mortar and rock-faced quoins. There are three windows, the largest of which is mullioned with cavetto mullions and transomes. It has a simple drip mould, is glazed with plain glass and is similar in appearance to the ground floor windows on the east elevation. The other windows have simple sandstone surrounds and have one-over-one sliding sash frames. The gutter is iron of ogee shape and the down pipe has a square-section.
- 4.10.8 The gablet projects from the main part of the elevation and is jettied; it is supported by moulded sandstone corbels and has a sandstone wall plate. The gablet is of squared random limestone construction with rock-faced quoins which are identical to those of the east and south elevations. There is a sandstone coping and a ball finial sits atop the ridge. The fenestration of the gablet comprises a tripartite mullion window, which contains three one-over-one sliding sash frames. It is of similar appearance to those on the ground floor of the east elevation.
- 4.10.9 ***North-Facing Elevation:*** the north-facing gable elevation of the Sound Archive building forms the south side of the small flagged courtyard between the Sound Archive and the Court House buildings (Elevation 2; Fig 13 Plate 68). The fabric is identical to the south-facing elevation discussed previously (*Section 4.10.4*). There are two mullion windows which have eared hood moulds and are similar to those already described. Each window is barred and they are glazed with one-over-one sliding sash windows. There are two kneelers and a chimney stack which are identical to those on the south-facing gable.
- 4.10.10 The base of this elevation is obscured by a single-storey projection which forms the entrance lobby (**Room L101**) and short corridor (**Room L109**) (Fig 10). This is
-



---

constructed from rock-faced sandstone with some pick marks and has a flat lead roof; it is clearly a later addition. There are three windows present, one of which has a distinct rock-faced surround. All three are barred and the aperture on the left has moulded jambs. The east end of this structure forms the main entrance (Plate 66).

- 4.10.11 **Roof:** the roof of the Sound Archive building is of pitched construction the axis of which runs north/south. There is a secondary pitched section with an east/west axis forming the gablet described above. The whole roof is covered with sandstone flags laid in diminishing courses with sandstone ridges and copings. There are three chimneys, all which are of similar construction details. A chimney located on the ridge of the east/west part of the roof has a chamfered plinth and two bishop chimney pots.

## 4.11 COURT HOUSE EXTERIOR

- 4.11.1 **East-Facing Elevation of the Courtyard:** a short corridor connects the two buildings on both floors, the east elevation (Elevation 3; Plate 69) of which faces the small courtyard. It is of neat squared random limestone construction with sandstone sill band and cornice (Plate 69). There are two lancet windows on the first floor with lugged sandstone surrounds and cusped apertures containing glazing with diagonal lead comes. Both windows are barred.
- 4.11.2 The ground floor contains a wide, segmental arch with chamfered and tooled sandstone voussoirs. This contains a doorway with flanking windows which are glazed with lozenge and diamond camed glass, some of which is stained. The roof of the corridor is of mono-pitch construction and is covered with sandstone flags.
- 4.11.3 **South-Facing Elevation:** the north side of the courtyard comprises the south-facing elevation of the Court House (Elevation 4) (Fig 13) which is, for the most part, constructed from the same fabric as Elevation 3 and exhibits a continuation of the sill band. There are two windows on the first floor which have lugged sandstone surrounds and cavetto mullions; they are glazed with the same lozenge and diamond camed glass as described elsewhere and each is barred.
- 4.11.4 The top of the elevation (and the whole building) has a moulded sandstone architrave above which are crenelations with moulded sandstone coping stones. Below *c* 3m in height the elevation is composed of random mixed fabric rubblestone with three small plain casement windows (Plate 70). There is a recess at the eastern extremity of the elevation, the origins and function of which are unknown. It is evident that the lower portion of this elevation relates to an earlier phase of the building.
- 4.11.5 **West-Facing Elevation of the Courtyard:** there is a small section of wall and segmental arch at the east side of the small courtyard. This is constructed from random squared and rubblestone fabric and has a saddle-backed coping.
- 4.11.6 **East-Facing Elevation of the Court House:** the east-facing elevation of the Court House building is constructed from the same neat squared limestone (not prominently quoined) and the sill band from Elevations 3 and 4 continues (Plate 11). The upper two thirds of the elevation is jettied with similar sandstone corbels and wall plate to that on the west elevation of the Sound Archive building. The lower left corner of the elevation is sandstone suggesting that it belonged to an earlier phase of building.
-

- 
- 4.11.7 There is a wide mullion window on the upper floor which is identical to that located in the east elevation of the Sound Archive building. It has the same glazing, hood moulding and other details. Three vertical slits are present below the jetty. A sandstone gatepost with ball finial is also present.
- 4.11.8 **North Elevation:** the north elevation is for the most part identical to the east elevation with only minor deviations in detail. The architrave respects the roof slope of the northern range of buildings and there is a small apex on the crenelation. A chimney flue has been added to the west side of the elevation, which has a sandstone stack.
- 4.11.9 **West Facing Elevation of the Court House:** the west-facing elevation of the Court House is high due to the sharp drop in ground level at this side of the range (Fig 14; Plate 12). Part of the elevation is obscured by vegetation and could not be inspected. The upper part is identical to the corresponding section of the east-facing elevation and the fenestration is also the same. It is jettied, has slightly different corbels, and there is no wall plate. The west-facing elevation of the connecting corridor is plain and similarly jettied. Below the jetty, the wall is constructed from mixed fabric random rubblestone. The extreme south end of the elevation is of random rubblestone construction and contains a plain one-over-one sash window set within a plain stone surround.
- 4.11.10 There are three slit windows and what appears to be a blocked window to the right of these (Fig 14). There is a vertical joint below the slit windows which might suggest rebuilding and remodelling. There is a soil pipe set within the wall at the right side of the elevation and some putlog holes are also present. A small stone outshut of unknown use is built against the elevation.
- 4.11.11 The roof of the Court House is of hipped construction with lead ridges. The roof is covered with sandstone flag laid in straight courses.

#### 4.12 SOUND ARCHIVE - INTERNAL DETAILS

- 4.12.1 The rooms within the Sound Archive and Court House buildings are numbered in a similar fashion to those in the Museum building (Figs 10 and 11). All the ground floor rooms are prefixed 'L' and all the upper floor rooms are prefixed 'U'. Description of the internal rooms will commence at the main entrance and follow a logical route around the building.
- 4.12.2 **Room L101:** this room forms the main entrance foyer and forms a later extension to the Sound Archive building. All the walls are plain ashlar with high narrow plinth, the floor is laid down to substantial flags and the ceiling is sandstone. The entrance doorway reflects its external appearance and has a substantial sandstone surround with a flat two-centred arch with recessed spandrels. Access to **Room L102** is available through a doorway to the left which has a chamfered sandstone surround with straight-cut stops; this formerly served as a principal external entrance to the Sound Archive building. A further doorway (now blocked) once allowed access to **Room L109** which has chamfered jambs.
- 4.12.3 **Room L102:** this is the largest room on the ground floor and is also the most decorative (Plate 71). Through this room access is afforded to rooms **L103, L109 and L108**. The floor is laid down to sandstone flags and the ceiling contains three north / south beams, each of which exhibits recessed panels.
-

- 
- 4.12.4 The most noticeable feature of this room is the large mullion window located in the east wall (Plate 72), the external characteristics of which have been discussed in *Section 4.10.3*. The mullions are cavetto moulded, while the transomes are ovolo (Plate 73). Each glazing panel has lozenge and diamond-shaped comes containing stained glass of three designs: a rose, a castle with shield and sword; and the initials B Q. A panel with an heraldic device is present in the centre of the window with the letters 'AMO' (Plate 73). The window has a panelled wooden seat and a decorative wooden surround with engaged columns; above the window is a panelled beam.
- 4.12.5 The doorways in the north wall are identical, each having an elaborate surround of similar design to that of the window (Plate 74). The top is decorated with fleur-de-lys and the jambs have engaged columns; the door is six-panelled and exhibits decorative panels.
- 4.12.6 Situated between the doors on the north wall of the room is a fine sandstone fireplace with decorative detail (Plate 75). It has a moulded two-centred arched opening which decorative scroll-stops with bars at the base. There are two quatrefoil and four multifoil motifs, together with fleur-de-lys projections and a heraldic device with the motto, in French 'HONI SOIT QUI MAL Y PENSE'. There is a simple grate and no insert.
- 4.12.7 A large built-in cupboard with similar carved detail to the door and window surrounds occupies the whole of the west wall of the room. It has three niches and modern matchboard panels have been inserted into the lower parts of each one. A secret door at the northern end allows access into a small cupboard (**Room L108**; Fig 10).
- 4.12.8 **Room L108**: this is a very small room which was last used as a storage room (Plate 76). The south wall has matchboard panelling up to approximately three feet in height, and is of nineteenth century appearance. Scars on the other walls suggest this formerly extended across the whole room, and, as such, this appears to reflect a localised survival of early decoration. The floor and ceiling are stone flagged; a simple timber beam supports the ceiling. There is a window set within the west wall which has a splayed and panelled reveal and is glazed with a one-over-one sash window with a mesh security grille.
- 4.12.9 **Room L109**: this room forms a short corridor through which access to **Room L110** is afforded (Fig 10). A wide, blocked doorway at the east end of the room originally allowed direct access from **Room L101**. The walls are painted and plain in appearance but are identical to those in **Room L101** and must have originally been plain ashlar. A plinth, identical to that in **Room L101**, is visible. The floor is laid down to carpet over stone and the ceiling is plain plaster. There are two small windows set within the north wall, both of which have stone moulded reveals and sloping sills; the reveals exhibit similar moulding to the external reveals. A modern gas boiler is fitted to the north wall.
- 4.12.10 **Room L110**: a half-gazed door allows access from **Room L109** into **Room L110**. There is a stone step up into this room which has a stone-flagged floor with two further steps up; it is a corridor which allows access both to the courtyard and **Room L111** (Plate 77). The east wall of this corridor is largely composed of the timber framework housing the door that accesses the courtyard (Fig 13; *Section 4.11.2*). There are two flanking windows and the door is half-glazed, all of which
-

---

are glazed with leaded glass of similar appearance to that already described. All of the diamond comes are glazed with green stained glass.

- 4.12.11 The west wall of the corridor forms part of the curtain wall of the range and is of stone construction which has been lime washed. There is a blocked window set within the wall which has a plain stone surround and two pintles suggesting that shutters were once present. This blocked window is visible on the west external elevation (Fig 14). Above the window a redundant gas light fitting is present together with stone projections of unknown origin.
- 4.12.12 The north wall of this room contains the doorway leading into **Room L111**, and has been partially rebuilt with brick; there is a further step up into that room. The door is identical to that accessing **Room L109**. There are two narrow window slits set within the west wall, both of which have splayed reveals and are glazed with modern glass (Plate 79). These are visible on the west external elevation (Fig 14).
- 4.12.13 **Room L103**: this room forms a small connecting corridor/room and access to **Rooms L104** and **L106** from **Room L102** (Fig 10). Structurally, the room is part of **Room L104**, and it has been created by the insertion of plasterboard partition walls. The doorway from **Room L102** is modern and is also located within a partition wall. The doorway allowing access to the staircase (**Room L106**) has a simple moulded architrave and is without a door. The floor is laid down to stone flags and the ceiling is plain.
- 4.12.14 **Room L104**: as already described, this room, together with **Room L103**, comprised part of a larger space (Plate 80; Fig 10); the general appearance of the room is similar to **Room L102** and all of the walls are plain plastered. The floor is part flagged and part timber floorboards. The ceiling contains two beams of similar appearance to those in **Room L102**. Two plain cast-iron columns support each beam. The skirting board is a simple torus moulded affair. A vertical scar/butt-joint in the north wall suggests that some rebuilding and/or the removal of a wall has been carried out.
- 4.12.15 The fenestration consists of two window apertures, one in each of the east and south walls which are stone-mullioned, containing glazing and are identical to that already described. The one on the east wall has four lights, that on the south, two. Both windows are set within splayed, panelled reveals with shutters, the window on the south wall has a walk-in reveal. There is a chimney breast in the centre of the south wall which probably contains a blocked fireplace and corresponds with the chimney stack at the apex of the south elevation.
- 4.12.16 **Room L105**: this is a small room accessible only from **Room L104** via a six-panelled door with moulded architrave. The room is plain and contains no decorative detail worthy of note. The floor is laid down to 8½ inch (0.21m) wide timber boards with some 4½ inch (0.114m) wide replacements and the ceiling is plain plastered. The fenestration consists of a single two-over-two sliding sash window set within a splayed reveal in the west wall.
- 4.12.17 There is a single fireplace set within the south wall, which has a stone surround and chamfered detail that is similar to those fireplaces on the second floor of the Museum building; it has a round-arched cast-iron late-Victorian insert. The opening has been blocked with cinder block and there is a slate hearth.
- 4.12.18 **Room L106/U104**: these rooms contain the staircase, which allows access to the upper floor of both the Sound Archive and the Court House buildings (Figs 10 and
-

- 
- 11). The walls are for the most part plain plastered, except for the east wall which is clad with matchboard. The floor in **Room L106** is laid down to flags and the ceiling in **Room U104** is plain plastered. There is direct access to a small store room on the half landing (**Room L107**). The fenestration consists of a single mullion and transom window with plain glazing set within a splayed reveal in the west wall. The surround has decorative elements similar to the carved engaged columns on the cupboards and architraves in **Room L102**.
- 4.12.19 The staircase is of oak open well (with landings) construction and is quite plain (Plate 81). The balusters and upper and lower newels are simply turned and the handrail is similarly plain. The newels on the half-landings are square with chamfered corners. Each newel has a mushroom-shaped turned cap. All the treads are covered with vinyl flooring and metal caps.
- 4.12.20 **Room L107**: this room is accessible from the half landing of the staircase via a substantial ledged and braced timber door and stone steps. It was obviously intended to store fragile or valuable items, as both the floor and ceiling have substantial sandstone flags (Plate 82). The room was originally intended to be at least partially fireproof or fire resistant and the ceiling is supported by a cast-iron parabolic beam (Plate 83). Two of the walls are lined with substantial stone shelving which exhibits furrow tool marks and is of similar appearance to shelving present in the basement of the Museum. Some rebuilding in brick has been carried out.
- 4.12.21 **Room U102**: there is a small landing at the top of the stairs (**U104**), from which access to **Rooms U102** and **U101** is afforded. **Room U102** is a plain, square room through which there is access to **Room U103**. The north-west corner of **Room U102** has a matchboard partition which has been inserted in order to create the top landing of the staircase; a six-panelled door is set into the partition and has a simple moulded architrave.
- 4.12.22 The floor is laid down to 8½ inch (0,21m) wide boards and the ceiling is plain. Two painted stone corbels are visible which appear to support a roof truss (Plate 84). There was no access to the roof space and the trusses could not be inspected.
- 4.12.23 The fenestration consists of three identical mullion windows, two set within the east wall and one in the south. All have splayed reveals and leaded glazing identical to that already described; all three have secondary glazing. Below the window in the south wall there is a short section of matchboard. The south wall contains a wide chimney breast which apparently (in common with **Room L104**) contained a fireplace; the stone hearth remains *in situ*.
- 4.12.24 **Room U103**: there are two steps down into this room which is small and quite plain in appearance. All the walls and ceiling are of plain plaster and a single north/south beam is visible. The ceiling respects the roof slope at the west side of the room. The floor is laid down to carpet over timber boards.
- 4.12.25 There is a single small window set within the west wall which has a three-over-three sliding sash frame. The reveal is splayed and there is a simple timber sill. A blocked fireplace is located on the south wall, but there is no chimney breast; the hearth is still visible below the carpet.
- 4.12.26 **Room U101**: this room is slightly higher than **Room U102** requiring two steps to access from the top landing (**Room U104**). It was obviously last used as a recording studio and sound absorbing foam material and acoustic plywood boxes
-

---

are still attached to some of the walls (Plates 85 and 86). Plasterboard partition walls at the south-west corner of the room create a small lobby through which **Room U105** can be accessed; the doors are six-panelled.

- 4.12.27 The floor is laid down to timber boards with some vinyl covering in areas. The ceiling respects the roof pitch and two corbels similar to those in **Room U102** are visible on either side of the room. Resting on these are the lower parts of two trusses which exhibit bead moulding; there was, though, no access to the upper part of the roof space.
- 4.12.28 The fenestration consists of two windows set within splayed and panelled reveals located on the north wall (Plate 85). Both sills are sloping and the frames are one-over-one sliding sashes, and both windows have stone-mullions, bars are present and each has secondary glazing.
- 4.12.29 **Room U105**: this is a small plain room located within the east/west pitched roof part of the building, with the west wall forming the gablet that is visible in the west elevation (Fig 14). The ceiling respects the slope of the roof and there is a ventilation opening of nineteenth century appearance (Plate 87). The last apparent use of this room was as a conservation studio. There is a wide timber mullion window set within the west wall which has a slightly splayed reveal and which is glazed with three one-over-one sliding sashes. A recess in the south wall may once have housed a cupboard or shelving.
- 4.12.30 **Room U106**: this room forms the connecting corridor between the Sound Archive building and the Court House (Fig 11). A label affixed to the door from **Room U101** (STOREROOM 1) suggests that this room was last used as a storage facility; indeed shelves containing boxes of archive film are present (Plate 88). The door from **Room U101** is of four panel style and is quite unlike any of the other doors in these buildings, each panel is decorative and the surrounding rails, muntins and stiles exhibit chamfering with straight-cut stops.
- 4.12.31 The room is quite decorative and appears to be of late nineteenth century date. All the walls are tile-hung with white glazed rectangular tiles and the floor is laid down to geometric black and red quarry tiling with decorative encaustics (but not similar to those floors in the Museum). There is a cast-iron grille running the length of the east side of the floor which would have provided heating.
- 4.12.32 The fenestration consists of two identical windows set into the east wall each of which is a lancet window with lugged sandstone surrounds and cusped apertures containing glazing with diagonal lead comes, some of which are stained and contain motifs identical to those described in **Room L102** (Plate 89). Timber shelving is attached to the west wall of this room, and appears to be earlier than or contemporary with the tiled floor, as the design of the latter respects the reduced width of the room due to the shelving.
- 4.12.33 The north end of this room contains a rather substantial iron door surround with built-in hinges, which must have housed a thick double door arrangement (Plate 90). Recesses in the jambs suggest a locking mechanism that is not unlike a safe lock, and is similar to that in the Museum building (**E002**). The side of the door surround-facing into **Room U107** is sandstone, but the current door is a feeble plywood affair.
-

---

### 4.13 COURT HOUSE - INTERNAL DETAILS

- 4.13.1 **Room L111**: access to this room is only via **Room L110** and it is, for the most part, of modern appearance. The room is divided into two parts, with the eastern part being a toilet (Fig 10). Most of the walls are of plasterboard construction, as is the ceiling, which has a single boxed-in beam. The north wall is of brick construction and has a blocked door (with cinder block), through which access to **Room L114** was once available (Fig 10). There are two narrow window slits set within the west wall, both of which have splayed reveals and are glazed with modern glass (Plate 79); these are visible on the west external elevation (Fig 14).
- 4.13.2 **Room L112**: this room is currently being used as a toilet and there are three toilet cubicles (Plate 97). Most of the walls are plain plastered except for the east wall which is of random rubblestone and part brick construction. The north wall is of brick construction. The floor is laid down to stone flags, which steps down from **Room L113**. The fenestration consists of two partially concealed windows with square reveals and casement window frames, in the south wall and two narrow slit windows in the east wall.
- 4.13.3 Each cubicle is of matchboard construction and has a half-glazed door of early twentieth century appearance. Two of the cubicles contain sanitary ware of nineteenth century appearance. Each of the toilet pans have makers names 'THE SAMSON WASH-DOWN CLOSET' (Plate 98) and 'VALE'. Each has a high level cistern. The other cubicle has a modern sink and toilet.
- 4.13.4 **Room L113**: this is a short corridor allowing access into **Rooms L114** and **L112** (Fig 10) from Room L115, and is for the most part unremarkable, but has a cobbled floor. All the doors are modern and a plasterboard partition wall separates this room from **Room L114**. There is a slit window in the east wall which is visible externally.
- 4.13.5 **Room L114**: this is a dark room lit by a single slit window in the west wall (visible on the west elevation Fig 14) (Plate 96). Various phases of blocking appear to have taken place and both the north and south walls have blocked apertures (Fig 10). Access was once available into **Room L111** and there are two other blocked doorways leading to other rooms to the north, which are blocked with either brick or cinder block. The whole of the south wall of this room has been rebuilt in brick. The floor is laid down to large cobbles which are identical to those in **Room L113** and the ceiling is of modern plasterboard.
- 4.13.6 **Rooms L115/L116**: these rooms lie outside of the scope of the investigation but the south wall of the Room L115 forms the northern wall of the Court House (Plate 95). It is constructed from random coursed squared limestone stone which is whitewashed. It has a single doorway allowing access to **Room L113**, and access to the other parts of the range is available via this room, as is egress to the castle ward.
- 4.13.7 **Room U107**: this is a large room, which exhibits identical decoration to **Room U106** (Section 4.12.31) (Plate 91). The walls and floor are identical and the ceiling is plain with a simple wooden cornice. There are cast iron grilles set into the floor, which conceal large diameter heating pipes (Plate 92). A substantial cast-iron radiator is fixed to the west wall. The fenestration consists of two wide, segmental-arched, mullion and transom windows, which are glazed with the same lozenge and diamond camed windows as those already described in other parts of the building (Plates 93 and 96). The east window (Plate 93) contains a heraldic motif, which is
-

---

identical to that observed in **Room L102**. There are two further, smaller windows located in the south wall of the room which exhibit identical features. All the windows have substantial lugged sandstone surrounds which exhibit chamfering with run-out stops. The other feature of interest in this room is a wide pine cupboard/shelving which is attached to the south wall (Plate 91). It has carved detail on the stiles, which consists of chamfering with a plinth and decorative top.

- 4.13.8 **Room U108**: an inserted doorway with concrete lintel in the north wall of **Room U107** leads into **Room U108** with is open up to the roof and contains a modern staircase leading down to **Room L115** (Fig 10). The staircase is contained within a plasterboard partition and lies outside of the scope of this investigation.

#### 4.14 THE GATEPOSTS

- 4.14.1 There are two square gateposts located at the end of the drive at the north-east corner of the development site (Figs 2 and 15). They are identical and are approximately 4.5m high, and 0.9m thick (square) and 3m apart; the only difference between them is that the western gate has been damaged by a large vehicle (Plate 99). Each is a substantial stone construction of yellow sandstone ashlar, and some of the faces exhibit furrow toolmarks. Most of the courses are approximately 4 inches (100mm) thick, the sixth course (from the base) of each post being six inches (150mm) thick. Both of the posts have been repointed with cement mortar at some time in the past. There are no gates present but the remains of iron hinges in the ground indicate that they formerly supported gates (Plate 100). Each of the posts sits on a chamfered plinth approximately 0.26m high (Plate 100) and has a decorative capital approximately 1m high with ovolo and cyma recta moulding; this is crowned with a pommel which has an embossed band around it (Plate 101). There is a benchmark incised into the base of the eastern gatepost.
- 4.14.2 Flanking the gateposts are stone walls, which are of random squared rubblestone construction (Plate 99; Fig 15), and form the boundary of the castle gardens. Low walls with sandstone copings line the drive to the south of the gate.
-



---

## 5. DISCUSSION

---

### 5.1 INTRODUCTION

- 5.1.1 The following sections draw together the information collected during the building investigation and present an outline of the architectural development of the individual buildings.

### 5.2 THE MUSEUM BUILDING

- 5.2.1 **Historical Evidence:** the history of the castle is long and the site has probably been occupied since at least 1102 (Adams 2006); however, with the exception of the keep the individual extant buildings within the ward are of much more recent date. An earlier sixteenth century illustration shows no buildings other than the keep, curtain walls and a gatehouse, which was subsequently demolished (*op cit*, Fig 3); however, this does not mean that other buildings did not exist as the castle was certainly used for administrative purposes from an early date. A Steward's House, Court House and Stable are illustrated on a drawing by Arthur Langshaw, produced in 1940, of a sketch of the castle from 1723 which is now lost (Adams 2006, 187; Fig 16) and is the first to show buildings other than the keep. The Steward's House occupies the site of the current Museum building, and is shown to be a long rectangular building with a single pitched roof, a tower and three chimneys, one of which has a distinctive projecting chimney breast. The building is of three storeys and has distinctive square windows with clearly illustrated shouldered hood moulds. The current building differs significantly from this illustration in that it has three pitched roof sections, no projecting chimney breasts and no obvious tower in the centre of the building. The window treatment of the current building also differs in that there are no hood moulds around any of the windows, which instead are a mixture of lancet windows and larger mullions. The illustration of 1723 does, though, show a doorway at the base of the east elevation which appears to be in roughly the same position as the current doorway allowing access to the basement. While there are clearly significant differences between the depiction and the present Museum building, this is not necessarily significant, as the sketch is very schematic and is not necessarily representative of the detail of the structure. In particular, it should be noted that the 1723 representation of the keep also differs substantially from the present day structure, the difference being that we know that the keep was in place at that time in its present form. The sketch shows four floors to the keep with a central window on each face floor of both faces shown, whereas it is evident that there were never this number of windows in existence.
- 5.2.2 The current building bears a more striking resemblance to the structure shown on a later illustration dated to 1781 by M Oddie (Adams 2006, 182; Fig 17). That structure is shown to have similar window treatment, the possible presence of a parapet, multiple chimneys and what is quite probably a square projection of a similar fashion to the South-East Tower on the current structure. The north-east elevation of the Museum is almost identical to the elevation-facing the keep on the illustration, with a very similar fenestration. More recent and detailed mapping confirms that the current layout of the Museum building was in place by at least
-

---

1886 (Fig 19) and may even have been established by 1847 (Fig 18), although this is somewhat difficult to discern from the OS first edition mapping.

- 5.2.2 **Phasing:** the building investigation has revealed that the building has undergone three main phases of construction and alteration with some modifications in the nineteenth century and cosmetic minor alterations and remodelling in the twentieth century.
- 5.2.3 **Phase I:** the first clear phase comprises the north-eastern half of the structure and is clearly illustrated by the vertical joins in the north-west and south-east elevations and the evident differences in fabric on both sides of these joins (Plates 5 and 17). The join on the south-east elevation is evidenced by quoins (Plate 17), and the change in fabric on the north-west elevation (Plate 5) clearly defines the south-western extent of a primary phase of construction. Internally, the doorway leading from **Room E011** to **Room E010a** (Figs 4 and 20) was probably the former rear door of the building. Interestingly, evidence of an earlier possible phase seems to exist with the semi-concealment of lancet windows in the rear of the south-east 'tower' (Plate 16). Further evidence for this is limited, however, and all the fabric of the north-eastern part of the building is of the same distinctive stone; however, it does raise the outside possibility that the tower may have served as an independent standing structure that was attached to the curtain wall.
- 5.2.4 The interiors of the north-eastern part of the building are distinctive and, although not ostentatious, are quite richly decorated. Most of the plaster work which adorns the ceilings and walls, notably in **Rooms E001, E012 and L005**, appears to be of late eighteenth or early-nineteenth century origin (Plates 31, 32, 49, 50 and 54). All of the internal doors are six-panelled and are probably of late-eighteenth or early-nineteenth century date, as are the fireplaces (although see below). The general layout and appearance of the house with probable servants quarters on the upper floor suggest that the building was intended to be a fine residence and the system of bell pulleys for calling the servants is testament to this. The basement of the Museum building appears to be part of the same phase of construction, as there is little evidence to suggest otherwise. It was probably extended when the upper floors were extended.
- 5.2.5 The Phase I structure was undoubtedly in place by the time of the 1781 drawing by M Oddie, and it is possible that it was also in place in 1723, but was misrepresented on the sketch. The other possibility, is that there was another building on the site that had a short life between the late sixteenth century and 1781, which was demolished to make way for the construction of Phase I of the present Museum building. An early eighteenth century sketched plan of Clitheroe Castle (Best 1990, 14) shows a much smaller, and simpler structure on the site of the Museum, which has its principal facade on the south-eastern side, which sported a stair turret and the principal entrance. The only element which would appear to correspond with the present structure is a small turret feature in the position of the South-East Tower, labelled the 'Fire Rooms'. The possibility exists that this was a predecessor of the Phase I structure and that the present tower was adapted from an earlier building; however, given the inaccuracy of both the depiction and the date of the sketch, little reliable interpretation can be made on the strength of it.
- 5.2.6 **Phase II:** this phase is represented by an 'L'-shaped extension set onto the gable end of the Phase I build. It had two storeys and contains further rooms, including kitchens (**Room E008**), which were functional and plain, and were evidently the
-

---

service quarters. Despite the plain interiors, the south-eastern facade was ornate and there was a clear intention to provide symmetry by producing a comparable projecting tower to the South-East Tower. On the north side of the building there was a further extension (Phase III) filling the gap between the Phase I build (Room E011) and the Phase II build (Room E008) (*Section 5.2.7*). There are few clear indicators that this Phase II build predated the Phase III filler extension, but perhaps the best indicator is a now blocked window in the north-west wall of **Room E006**. The blocked window has the splay extending into **Room E006**, which would indicate that the south-eastern side of this wall was the internal side and the north-western side was external. Consequently, the Phase III filler extension post-dated the 'L'-shaped Phase II extension, and for a period there would have been an open courtyard extending out from the north-western facade of the building. This is confirmed by the OS 1847 6" to 1 mile map (Fig 18), which shows the Phase II extension and the four large buttresses against the south-eastern facade and what appears to be a rectangular courtyard set in from the north-western side. As the buttresses at the base of the south-east elevation (Plate 7) were shown on the OS first edition map (1847) (Fig 18), they evidently predated the map and two of them provided support for the Phase II build; therefore, it is probable that they belong to this phase. Although not shown on the map, the construction of the rear sunken walkway also probably dates to this phase.

- 5.2.7 *Phase III*: the building has clearly been extended to the south-west as evidenced by the vertical join in the north-west elevation. It is apparent that the Phase III extension was confined to a new, three storey 'wing' on the north-west of the rear side of the building (Figs 6 and 20; Plate 44). The fabric is quite different from that of Phases I and II, but is very similar to the fabric of the Sound Archive and Court House buildings. Given the evidence of the internal blocked window in the north-west wall of Room E006 (*Section 5.2.6*) it is evident that this was a later infill of a former courtyard. The design, and particularly fenestration, was intended to match up with the rest of the structure, although there are slight differences in the windows of the north-west elevation between the three phases (Plates 4 and 5); similarly, the quoins and general masonry are better dressed than those of the previous two phases. The unusual aspect of this phase is that it was a three-storey structure and the upper storey was in part constructed on top of the two-storey Phase II build. The construction of this wing was intended to provide independent stair access for the servants wing, and further divides the genteel and service ends of the building. The stair access into the basement (extending from **Room E010b**) was evidently also constructed as part of this phase. The courtyard had been filled by the time of the OS 1886 map and therefore the Phase III build dates between 1847 and 1886.
- 5.2.8 *Phase IV*: the addition of the balcony, steps and front porch were carried out later, probably in the later nineteenth century. Internal modifications, such as the laying of encaustic floor tiles in **Room E001** and hearth in **Room E012**, together with the installation of gas lights, were also probably carried out in the nineteenth century. All the chimney stacks and the parapet are of the same phase; they clearly post-date the Phase III build, and were therefore probably of late nineteenth century date.
- 5.2.9 *Phase V*: twentieth century remodelling, such as the removal of some fireplaces and internal walls, has taken place. The roof timbers and coverings are all of relatively recent date. Similarly, all the museum displays and are of modern construction.
-

---

5.2.10 **Conclusion:** the Museum building probably dates to the late eighteenth century and although quite reserved in execution, is an example of eighteenth century gothic or ‘gothick’ revival. No trace of a former structure exists, although more detailed investigation may shed further light on this.

### 5.3 THE SOUND ARCHIVE AND COURT HOUSE

5.3.1 In common with the Museum building, these structures were in place, essentially in their present form, by at least 1886 (Figs 19 and 21). They were obviously two separate structures, which have been joined by the addition of a two-storey corridor, visible from the small courtyard (Plate 69), which itself was partly enclosed at a relatively late date. The present Sound Archive building has the appearance of an earlier construction than the present Court House, which was constructed in ashlar and is of very ornate construction. The fabric of the Sound Archive building has a mid-eighteenth century character, whereas the Court House has a mock Elizabethan, crenelated character that was common of the mid nineteenth century; however, there is evidence of fabric earlier than both buildings evident particularly in the western curtain wall.

5.3.2 **Historical Evidence:** the illustration by Arthur Langshaw reproduced in 1940 of a 1723 drawing (Adams 2006, 187; Fig 16) shows a Court House and separate Stable, although the depicted Court House corresponds with the location and general form of the Sound Archive building. It would appear that the Sound Archive building originally functioned as the Court House and then the current Court House was added at a later date. The Langshaw depiction of the then Court House has a generally similar window treatment to the current Sound Archive building; however, it has already been established (*Section 5.2.1*) that this illustration is very schematic and can not be relied upon as an indicator of the original form. The illustration by M Oddie (dated 1781) (*op cit* 182, fig 2) partially illustrates buildings present in this area and it is clear that the then Court House was separate from the stables, and the fenestration was similar to that evident today on the Sound Archive building. This engraving is much more reliable and there is an implication that the Sound Archive building in its present form was in place at that date. By contrast, the then stables bear very little similarity with the present Court House and it is evident that the latter had not been constructed by this date.

5.3.3 **Fabric evidence:** the two buildings are constructed from dressed limestone blocks, although the Court House was constructed of more finely-worked stone and was obviously of a very different design (Plates 10, 11, 12 and Fig 14); however, there are similarities of fenestration which may reflect a desire for the later structure to be compatible with the earlier. There is the same decorative stained glass, but this may reflect a later insertion. There appear to be four main phases of construction.

5.3.4 **Phase I:** this phase comprises the original construction of the curtain wall and encompasses earlier fabric of the previous Court House and Stables. This is evident on the west elevation (Figs 14 and 21; Plate 12), where the lower parts of the Court House (Plate 70) are of poorly-coursed, roughly-dressed masonry and the few blocked windows have relatively crude red sandstone quoins. The form and character of the underlying structure is consistent with that of a stable. Parts of the curtain wall are visible internally, particularly in the connecting corridor between the two buildings (Plates 78 and 79) and earlier fenestration is visible.

---

- 
- 5.3.5 The west elevation of the Sound Archive building is again constructed of roughly-coursed, mixed rubblestone construction, and is of very different construction to the other elevations which are constructed of dressed limestone. The gablet is of a clearly different build, and evidently a later insertion into the west wall; it is of a similar construction as the south and east walls and was probably a contemporary build. The smaller windows have simple sandstone surrounds, and contrast with the elaborate mullioned window with cavetto mullions and transomes, which are comparable to those on the east elevation. It is therefore probable that the smaller windows belong to Phase 1 and the elaborate mullioned window was a later insertion. This early fabric probably corresponds with the Langshaw early eighteenth century depiction of the first Court House and the Stable.
- 5.3.6 **Phase II:** the rebuilding of the Sound Archive (the original Court House) probably took place at some point in the late eighteenth or early nineteenth century. The earlier west face of the building has no obvious vertical or horizontal joins, which would imply that the building has not been extended or raised. The build of the south, west and east elevations have a very distinctive and uniform character comprising well-dressed rock-faced limestone, and very distinctively has rock-faced quoins. The uniformity would imply that these walls were broadly contemporary, and given that the footprint of the building has not apparently changed there is also the possibility that this reflects a refacading rather than a complete rebuild of these walls. The gablet on the first floor of the west elevation is of the same build as the other elevations of this phase and was almost certainly a contemporary insertion. Similarly, the large mullioned window, adjacent to the gablet, was of a form comparable to those on the east elevation and it was probably inserted at the same time that the building was rebuilt / refacaded. Most of the internal decoration of the building probably dates to this phase, particularly the impressive doorways in **Room L102**, and it is probable that the fireplace in this room may similarly date to this phase.
- 5.3.7 Given that this phase of building has adopted an earlier footprint and may be a refacading, it is very difficult to establish the date of the work from engravings or plans. The Oddie engraving has an indistinct representation of the building, which is similar to the present form of the building. The only noticeable distinction is that there appears to be a door depicted below the two first floor windows, whereas now there is a large mullioned window. This may be an indication that Oddie was engraving the building prior to the Phase II alterations, when there was a door in this position, in which case these major building works post-date 1781. An engraving dated to 1835 shows the west side of the castle and the Sound Archive building (then Court House) is depicted without the gablet, and it is evident that the Phase II works post-date this engraving (Best 1990). An episode of restoration of the keep was undertaken in 1848, and entailed the buttressing of the keep (*op cit*, 16) and its possible that improvements to the other castle buildings were also implemented at this time.
- 5.3.8 **Phase III:** the current Court House building, together with the connecting corridor was constructed during this phase (Figs 21 and 22). This reflects a very significant departure from the previous stable structure and is almost certainly a new build, albeit constructed, at least on its western side, on the foundations of the earlier stable. The interior decoration of this building, together with the connecting corridor is of obvious mid-late nineteenth century date. The encaustic floor tiles and tile-hung walls are obvious late nineteenth century features. All the stained glass
-

---

was probably added during this phase. The build is of a very uniform style and it would appear that the whole of the rectangular Court House was constructed as a single build as part of this phase.

- 5.3.9 The Oddie engraving shows the form of the earlier stable, and therefore the Phase III rebuild clearly post-dates 1781. The OS 1st edition 6" to 1 mile (1847) map (Fig 18) does not show sufficient detail to reveal if the new Court House had been constructed on the foundations of the stable. The first edition OS 1:2500 1886 map shows the outline of the courtyard structures (Phase IV) and, therefore, the new Court House must have been in place by that date.
- 5.3.10 **Phase IV:** the final major phase of construction resulted in the addition of the main entrance, lobby and short corridor (**Rooms L101 and L109**) for the Sound Archive building. This is of clearly differing fabric, and it butts onto the eastern wall of corridor **L110**, which is an element of the Phase III build. This extension to the Sound Archive building is shown on the first edition OS 1:2500 (1886) map and was probably established subsequent to the OS 6" to 1 mile map (1847), although the latter map is of insufficient resolution to be able to determine this with any reliability.
- 5.3.11 **Phase V:** the installation of sound proofing and other fixtures and fittings was carried out for the South Archive building in the late twentieth century. The blocking of some internal doorways also dates to this phase.
- 5.3.12 **Conclusion:** the Sound Archive and Court House buildings have undergone much modification; the Sound Archive building was substantially modified in the late eighteenth / early nineteenth centuries and the later Court House was constructed on the foundations of the stable in the mid nineteenth century.

## 5.4 THE GATEPOSTS

- 5.4.1 These appear to be of a single phase of construction and probably date to at least the early nineteenth century. The curtain wall is of less ornate construction and may be earlier.
-

---

## 6. BIBLIOGRAPHY

---

### 6.1 PRIMARY AND CARTOGRAPHIC SOURCES

- British Geological Survey Clitheroe and Gisburn 1970 1:25000  
Ordnance Survey first edition 1847, *Lancashire Sheet 47, 6"*: mile  
Ordnance Survey 1886 first edition, *Lancashire XXXVII*, 1:2500  
Ordnance Survey 1914 second edition, *Lancashire XXXVII*, 1:2500  
Ordnance Survey 1932 third edition, *Lancashire XXXVII*, 1:2500

### 6.2 SECONDARY SOURCES

- Adams, P, 2006 Clitheroe Castle, *The Castle Studies Group Journal*  
Best, D, 1990 *Clitheroe Castle: A guide*, Lancaster  
Brock Carmichael Architects April 2004, *Conservation Plan for Clitheroe Castle and Museum*  
Clarke, GT, 1877 *Medieval Military Architecture*, London  
Codrington, T, 1919 *Roman Roads in Britain*, London  
Department of the Environment, 1990 *Planning Policy Guidance 16: Archaeology and Planning* (PPG 16)  
Department of the Environment and Department of National Heritage 1994 *Planning Policy Guidance Note 15 – Planning and the Historic Environment*, Swindon  
Earp, JR, Magraw, D, Poole, EG, and Whiteman, DH, 1961 *Geology of the County Around Clitheroe and Nelson*, London  
English Heritage, 1991 *Management of Archaeological Projects*, 2nd edn, Swindon  
English Heritage, 2002 *Environmental Archaeology: A Guide to the Theory and Practice of Methods, from Sampling and Recovery to Post-Excavation*, London  
English Heritage, 2006 *Understanding Historic Buildings: A Guide to Good Recording Practice*, London  
Farrer, W, and Brownbill, J, 1911 *The Victoria History of the County of Lancaster*, **6**, London  
Institute of Field Archaeologists 2001a, *Standard and Guidance for the archaeological investigation and recording of standing buildings or structures*  
Institute of Field Archaeologists 2001b *Standard and Guidance for archaeological desk-based assessment*  
Institute of Field Archaeologists 2002a, *Code of Conduct*  
Institute of Field Archaeologists 2002b, *Code of approved practice for the regulation of contractual arrangements in field archaeology*  
Kenyon, D, 1991 *The Origins of Lancashire*, Manchester, 11
-

- 
- L and R Consulting, Brock Carmichael Associates, Headland Design Associates, May 2003, *Feasibility Study and Conservation Plan for Clitheroe Castle and Museum, Interim Report*
- Lancashire County Council, 2006 *Lancashire Historic Town Survey Programme: Clitheroe. Historic Town Assessment Report*, Preston
- Langshaw, AL, 1947 *A Guide to Clitheroe Castle*, Clitheroe
- Museums' and Galleries' Commission, 1992 *Standards in the Museum Care of Archaeological Collections*, London
- Newman, RM, 1996 The Dark Ages, in R Newman (ed), *The Archaeology of Lancashire*, Lancaster
- OA North, 2007 *Clitheroe Castle, Lancashire, Archaeological Evaluation*, unpubl rep
- Standing Conference of Archaeological Unit Managers (SCAUM), 1997 *Health and Safety for Field Archaeologists Manual*, 3<sup>rd</sup> Edition, Southampton
- United Kingdom Institute for Conservation (UKIC), 1990 *Guidelines for the Preparation of Archives for Long-term Storage*, London
- University of Manchester Archaeology Unit, 2003 *Clitheroe castle, Moor Lane, Clitheroe: Archaeological Watching Brief* (unpublished client report for RVBC)
- Weeks, WS, 1926 Clitheroe in the Seventeenth Century, *Trans Lancashire Cheshire Antiq Soc*, **41**, 44-78
- Whitaker, TD, 1872 A history of the original parish of Whalley and the Honour of Clitheroe, 4th edn, Manchester
- White, A, 1996 Medieval Towns, in R Newman (ed), *The Archaeology of Lancashire*, Lancaster
-



---

## APPENDIX 1: PROJECT BRIEF

---

SPECIFICATION FOR ARCHAEOLOGICAL BUILDING RECORDING  
AT Clitheroe Castle  
(SD 742416 ac)

**Prepared on behalf of Ribble Valley Borough Council**

### **1. Summary**

Ribble Valley Borough Council (RVBC) has developed a large scheme for the refurbishment and revitalisation of the Clitheroe Castle site. Brief details of the scheme can be found on the council web site under the Clitheroe Castle Heritage Scheme banner and further documentation and drawings with the planning applications 3/2006/1047 and 3/2007/0039.

Because of the historic nature of the building it has been recommended that a programme of archaeological works, including building recording, should be devised and implemented before work is carried out. This brief deals with the building recording element of the programme and has been drawn up by Lancashire County Archaeology Service (LCAS).

This recommendation follows the advice given by central government as set out in *Planning Policy Guidance: Planning and the Historic Environment* (PPG 15) and *Planning Policy Guidance: Archaeology and Planning* (PPG 16) issued by the DoE/DoNH, and policies G1, ENV14 and ENV15 of the Ribble Valley District wide Local Plan.

### **2. Site Location and Description**

- 2.1 The castle complex stands above the southern end of Clitheroe, with the Norman keep standing on a limestone knoll at the highest point of the site, centred at NGR SD 74245 41693. In form this is not unlike a small motte, although it is in this instance a rock knoll and not an earthen mound. The castle bailey or ward extends downwards to the south and east, and is entered through the north east corner. It incorporates two main ranges of building, the Steward's House, which houses the castle museum, and the former Court House and stable range, which houses the North West Sound Archive as well as having storage and grounds maintenance functions. These building ranges are listed in their own right and date to the early-mid 19<sup>th</sup> century.
- 2.2 Some remains of medieval curtain walling still stand, including a section of sub-circular walling around the base of the keep, a straight section linking this to the site entrance and, at the southern end of the site, a straight section leading south from the stable range. These walls, along with the building ranges mentioned above and a wall to the south and east, form the boundary of the development site. Open ground within these bounds includes roads, paths and parking areas, a cenotaph and associated memorial garden, and an area formerly occupied by the greenhouses and yards of the council parks department. To the north and east the castle site adjoins the built-up medieval streets of Moor Lane and Castle Gate, whilst to the south and west is the castle park and recreation ground.

### **3. Planning Background**

- 3.1 The proposed works have been carefully designed to minimise the impact on the historic fabric of the castle complex, but will still require some alterations as well as the construction of a new link building. The impact of this new build on buried remains will be dealt with
-

---

elsewhere, but the works will impact on the museum and stable range. Works will include the demolition of an outbuilding and the insertion of a new single storey extension, the removal of existing fabric to provide new openings, insertion of new partition walls, the blocking of former openings and the erection of a single etc

- 3.2 Details of the developments are set out in planning applications 3/2006/1047 and 3/2007/0039, details of which are available on the RVBC web site. The former application in particular is accompanied by a large number of drawings and plans setting out the site as existing and the proposed works.
- 3.3 A conservation plan (Brock Carmichael Architects, April 2004) has been compiled for the site and adopted by RVBC, to inform the proposals for the site. This report built upon an earlier feasibility study (L & R Consulting, Brock Carmichael Associates, Headland design Associates, May 2003), which sets out sketch proposals for development.

#### **4. Archaeological Background**

- 4.1 The castle site at Clitheroe cannot be accurately dated, but a charter of 1102 confirms the existence of some defences in the form of 'le baille'. A further charter of 1122 grants the chapel within the castle to the monks of Pontefract. It is generally accepted, however, that the present tower keep was built by the de Lacy family during the 1180s. It has been suggested that the curving wall at the base of the keep represents the remains of a shell keep, pre-dating the erection of the present square tower keep.
- 4.2 As well as the obvious military value, the castle site was also used to manage the de Lacy's large estate, the Honour of Clitheroe, as well as acting as a gaol. By the seventeenth century the castle site had become dilapidated and ruinous and estimates for its repair rose from £81 in 1602 to £177 in 1608.
- 4.3 During the Civil War the castle was briefly occupied in 1644 by elements of the Royalist army, and in 1649 was taken over by men of the Parliamentarian Lancashire Militia, who refused to disband until their arrears of pay were settled. Later that year the castle was ordered to be slighted and rendered unfit to be held against Parliament, but there is some dispute as to whether this was actually carried out.
- 4.4 The ruins of the castle were partly restored between 1848 and 1853 and in 1919 Lord Montague of Beaulieu sold the site to the people of Clitheroe, the castle grounds being established as a memorial to the Clitheroe victims of the Great War. A brief history of the site is given by Paul Adams in *The Castle Studies Group Journal* of 2005-6 (No.19 pp.179-192) along with a description of the surviving medieval elements and a number of useful plans and illustrations.
- 4.5 The castle site is protected as a Scheduled Monument (SM27747), with the keep and associated walls also being listed grade I. The present Steward's House is listed grade II and assigned to the early-mid 19<sup>th</sup> century in the listed building description (but see below). The stable range is also listed grade II and is also noted as being of the mid 19<sup>th</sup> century, but earlier stonework appears to survive within this range. The present museum building appears to be very different from the 18<sup>th</sup> century building on this site shown in Adam's fig.11 dated 1723, but has significant similarities with that provided as fig.2, dated 1781 (op. cit.) and it is possible that sections of earlier fabric may also be retained within the structure. Neither of these two buildings are shown on the late 16<sup>th</sup> century view drawn up as part of a review of the castles of Lancaster Duchy, a copy of which is provided by Adams as fig.3 (op. cit.).
- 4.6 Little formal archaeological investigation of the castle has taken place in recent years. Two small watching briefs were held on works at the castle in 1991 and 2002, but produced limited results. Trial excavations designed to assess the archaeological potential and allow the formulation of a mitigation strategy were however held in December 2006 by Oxford Archaeology North. These showed that medieval deposits survived at very shallow depths
-

---

in the area of the keep, but that deposits at the southern end of the ward were both deeper and overlain by later material.

- 4.7 The park and recreation ground to the south and west of the castle is included in the Register of Parks and Gardens of Special Historic Interest, and the area is also part of a Conservation Area. Appendix 1 includes the Schedule entry, Listing description, Register entry and other details from the Lancashire Sites and Monuments Record.
- 4.8 Proposals for the buildings on site include the refurbishment of the present Steward's House museum premises, and the restoration of the stable block to house temporary exhibitions, provide staff accommodation and education facilities. These works, along with the alterations and building work to the existing structures necessitated for the new link block across the southern end of the site, mean that a scheme of building recording is required in addition to the archaeological mitigation works.

## **5. Requirement for Recording**

- 5.1 Buildings are an important part of the historic environment, providing information on historical technology, social structure and lifestyles. Alterations to such buildings remove evidence for the past uses and occupation of the buildings and make it more difficult for future historians to understand and interpret the buildings. A drawn and photographic record of the building preserves 'by record' the information that is lost during alteration.
- 5.2 Two basic levels of building recording are proposed: (i) Where intervention is minimal and repairs are on a simple like-for-like basis then a simple photographic record will be sufficient. (ii) Where more major interventions, including blocking existing openings, breaking out new openings, or obscuring walls with new construction, then a modified level 3 record will be required. The general specifications for these recording levels are set out in *Understanding Historic buildings: A Guide to Good recording Practice* (English Heritage, 2006). The guidelines set out in the Institute of Field Archaeologists (IFA) Code of Practice (IFA 2002a,b) and the applicable IFA Standards and Guidance (IFA 2001a,b) should also be used.
- 5.3 Except where specified in 5.4 below, the structures of the stable range and Stewards House (museum), and both faces of the curtain walling at the southern end of the castle ward between these two building ranges should be subject to a rapid photographic record, as set out in section 8 below. Where accessible the curtain walling on the east side of the castle ward, leading north from the Stewards House, the curtain walling and gateway features at the north east corner and the straight section of the curtain walling leading to the circular wall at the foot of the castle knoll on the north side of the ward should also be photographed.
- 5.4 The following areas should be subject to a modified level 3 record, to include the drawings and description set out in section 7 below:
- The south-facing elevation at the south end of the stable range (Elevation 1 on drawing 6210 AL 321).
  - The north, west and south elevations within the courtyard between the Court House at the south end of the stable range and the main section of the stable range and both sides of the eastern courtyard wall/gateway – this recording should not include the modern lean to on the southern side of the courtyard (which should be photographed instead) but should include the wall to the Court House behind this structure (to include Elevations 2, 3, and 4 on drawing 6210 AL 321).
  - The section below the jettied out upper extension of the east-facing elevation (i.e. the outside face of the ward boundary walls) of the section of stable range from the court house to the archive room (the shaded section of wall in Elevation 2 on drawing 6210 AL (0) 322)
-

- 
- At the entrance driveway in the north eastern corner of the ward, the exposed faces of the western gate pillar and 3m of the north face of the curtain wall immediately to its west.
  - The two-storey south elevation of the southernmost part of the museum building (drawing 6210 AL 125).
  - The western side of the southernmost section of the museum building, i.e. that two-storey section to be obscured by the new link building and shown partly shaded for removal of ivy on drawing 6210 AL 126. Note that this record will need to be made after the removal of the ivy and other growths here.

## **6. Documentary research**

- 6.1 A programme of documentary research is not required as part of this brief, although such work will be needed as part of the overall scheme of works. Unless such a programme of works has already been completed, then the summary of the site provided by L and R Consulting (2003), Brook Carmichael (2004), Adams (2006) and Oxford Archaeology North (2007) should be used to inform the contractor of the general history and development of the site.

## **7. Drawn Record**

- 7.1 The building should be carefully examined prior to the commencement of recording, in order to identify all features relevant to the original and subsequent historical uses of the site. These features should then be incorporated into the final drawn record; English Heritage drawing conventions will be followed. The following list should not be treated as exhaustive, but items of interest would typically include:
- All structural elements (including posts, columns, etc)
  - Original doors and windows, including associated shutters or other fittings
  - Any significant changes in construction material, including significant changes in stone type and size
  - Any blocked openings
  - Evidence for phasing, and for historical additions or alterations.
  - Evidence for construction techniques and sequences. Typical features of interest may include tool marks left over from the preparation of structural timbers, carpenters' marks, etc.
- 7.3 A scale plan of each area specified in 5.4 above should be made. Existing plans (e.g. plans submitted with the planning application) may be used as the basis for the drawn record; it is the responsibility of the archaeological contractor to ensure the accuracy of any existing drawings and to make any necessary adjustments or corrections. The scale to be used will be discussed and agreed with LCAS.
- 7.4 Elevations of those areas specified in 5.4 above. Existing elevations (e.g. elevations submitted with the planning application) may be used as the basis for the drawn record; it is the responsibility of the archaeological contractor to ensure the accuracy of any existing drawings and to make any necessary adjustments or corrections. The scale to be used will be discussed and agreed with the LCAS.
- 7.5 Where they are necessary for understanding of the building's design, development of function, the drawn record should include representative sections at a suitable scale.
- 7.6 Drawing conventions should conform to English Heritage guidelines as laid out in *Understanding Historic Buildings – A guide to good practice* (op. cit).
-

---

## 8. Photography

- 8.1 General photographs of the interior and exterior of the building complex are required, along with photographs of the site/setting of the building. These can be taken with a 35mm camera (Medium or Large Format cameras may also be used). Detailed photographs of areas to be affected by the development are also required and are to be taken with a Medium or Large Format camera with perspective control. All photographs are to be black and white. All detailed photographs must contain a graduated photographic scale (measuring tapes and surveying staffs are not considered to be acceptable scales in this context). A 2-metre ranging-rod, discretely positioned, should be included in a selection of general shots, sufficient to independently establish the scale of all elements of the building and its structure.
- 8.2 This basic photographic record is also to be supplemented by colour slide photography where colour is an aspect that needs to be recorded, e.g. decorative finishes. A suitable photographic scale and standard colour bar should be included in such photographs.
- 8.3 Detailed photography should include:
- The overall appearance of principal rooms and circulation areas.
  - Detailed coverage of the building's external appearance
  - Any external detail, structural or decorative, which is relevant to the building's design, development and use and which does not show adequately on general photographs.
  - Each building's relationship to its setting and to other buildings.
  - Internal detail, structural and decorative which is relevant to the building's design, development and use and which does not show adequately on general photographs. Elements for which multiple examples exist (e.g. each type of roof truss, column or window frame) may be recorded by means of a single representative illustration.

Detail photographs must be taken at medium-to-close range and be framed in such a way as to ensure that the element being photographed clearly constitutes the principal feature of the photograph. Where a record board or slate is included in the frame, it should be positioned such that it is readable in the photograph but does not obscure important detail.

- 8.8 For the purposes of the report, high quality digital images (i.e. a camera resolution greater than 8 Mega Pixels) are acceptable.
- 8.9 Archive photographs should be taken with a conventional 35mm, Medium or Large Format camera as above. All record photographs are to be black and white, using conventional silver-based film only, such as Ilford FP4 or HP5, or Delta 400 Pro (a recent replacement for HP5 in certain film sizes such as 220). Dye-based (chromogenic) films such as Ilford XP2 and Kodak T40CN are unacceptable due to poor archiving qualities. Digital photography is unacceptable due to unproven archiving qualities. A suitably stable colour slide film should also be used.
- 8.10 Record photographs should be printed at a minimum of 5" x 7". Bracketed shots of identical viewpoints need not be reproduced, but all viewpoints must be represented within the report.
- 8.11 A plan at a suitable scale (1:50 or 1:100), for each floor, showing the location from which the photographs have been taken shall be produced. The annotation of architects plans for this purpose is acceptable.
- 8.12 A photographic register listing all photographs (b/w prints, colour slide or digital images) taken shall be produced. For ease of use each set of photographs should be numbered sequentially 1, 2, 3, etc.
-

---

## **9. Adherence to specification**

- 9.1 Prior to the commencement of *any work*, the archaeological contractor should confirm in writing adherence to this specification, or state (with reasons) any proposals to vary the specification. Should the contractor wish to vary the specification, then written confirmation of the agreement of the LCAS to any variations is required prior to work commencing. The archaeologist carrying out the watching brief should be appropriately qualified and experienced. Any technical queries arising from the specification detailed below should be addressed to the LCAS *without delay*.

## **10. Monitoring**

- 10.1 The Lancashire County Archaeological Service will be responsible for monitoring the contractor's work. The contractor must give a minimum of one week's notice, in writing or by e-mail, of the commencement of fieldwork in order that arrangements for monitoring can be made.

## **11. Post-Recording Work and Report Preparation**

A written report shall be produced. This will include:

- 11.1 The location of the building, including name or street name and number, town, civil parish, and National Grid Reference. Details of listing and scheduling.
- 11.2 The date when the record was made and the names of the recorders and the organisation which employs them (e.g. Unit name) as well as the reason for the record (to meet the requirements of a planning condition) and quoting the relevant planning application or Listed Building Consent reference (see 1. Summary).
- 11.3 A description of the building elements recorded. This should describe the plan, form, function, age and development sequence as deduced during the recording process. A full and formal description of the development of the whole castle complex is not required as part of this exercise, however (see 6. Documentary research). The purpose of this is to describe the building when no fuller record is required and to serve as an introduction to a more detailed record that may follow.
- 11.4 Where necessary an account of any successive phases of development, and of the evidence supporting this analysis should be provided.
- 11.5 An account of any fixtures, fittings, plant or machinery associated with the buildings should be provided, but this does not need to include any museum displays or features.
- 11.6 Any evidence for the former existence of demolished structures or plant associated with the building should be given.
- 11.7 Copies of other records of the building, or a note of their existence and location.
- 11.8 Relevant information from other readily available sources and from other people such as owners, building contractors or architects) who may be familiar with the building. Sources of such information should be given.
- 11.9 A note of the building's past and present relationship to its setting: for example its relationship to local settlement patterns, particularly settlement patterns contemporary with the building, to a field system, to a park, garden, moat, graveyard or other man made landscape; its part in a larger architectural or functional group of buildings, its visual importance as a landmark, etc.
-

- 
- 11.10 A note of the significance of the building locally, regionally or nationally, in terms of its origin, purpose, form, construction, design, materials or status.
- 11.11 The report illustrations should include as a minimum: a location map at not less than 1:2500; a site plan at not less than 1:500 with the building(s) being recorded clearly marked; photographs used to illustrate key points and a complete set of site drawings, at an appropriate scale, executed to publication standard. Extracts from any historic maps studied are also to be included within the report with the building/buildings of interest clearly visible. All copyright and Licence agreement numbers should be included on maps. The photographic record plan and register must also be included as an integral part of the report.
- 11.12 A copy of this specification should be bound into the back of the report.
- 11.13 A fully indexed archive is to be compiled consisting of all primary written documents, plans, photographic negatives and a complete set of labelled photographic prints. Labelling should be in indelible ink on the back of the print and should include: film and frame number; date recorded and photographer's name; name and address of feature/building; national grid reference. Printed adhesive labels are also acceptable. Photographic prints should be mounted in appropriate archival stable sleeves.

## **12. Deposition of archive**

- 12.1 The ARCHIVE resulting from building recording will be deposited with the Museum of Lancashire, Stanley Street, Preston, PR1 4YP; T. 01772 534075, F. 01772 534079 in a format to be agreed with the County Museum Officer, and within a timetable to be agreed with the Specialist Advisor (Archaeology) or Planning Officer (Archaeology). A summary record of the building with appropriate illustrations will be deposited with the Lancashire Sites and Monuments Record and with the National Monuments Record in Swindon.
- 12.2 The site archive shall be conserved and stored according to the UKIC *Guidelines for the preparation of excavation archives for long-term storage* (1990) and the Museum and Galleries Commission *Standards in the Museum Care of Archaeological collections* (1992) 'Standards for the preparation and transfer of archaeological archives'.
- 12.3 As this recording work forms part of a larger scheme of archaeological works, it may be acceptable for the contractor to delay the production of a final report until all sections of the works have been completed. If this is to be considered then this should be discussed and agreed in advance with the Specialist Advisor (Archaeology) or Planning Officer (Archaeology).
- 12.4 A copy of the final report will be submitted to the Lancashire Sites and Monuments Record within 12 weeks of the completion of the fieldwork for comment. This should be provided as an Acrobat Adobe 'PDF' format file on CD-ROM and should include copies of all digital photographs as TIF or JPG files. Digital survey drawings should be provided as AutoCAD DWG files, with plans georeferenced as appropriate. If requested paper copies should also be supplied to the relevant Planning Officer and Conservation Officer at Ribble Valley Borough Council.
- 12.5 Provision and agreement shall be made for the appropriate academic publication of any results that are not to form part of any further work. As a minimum a brief summary report of fieldwork, to appear in the Council for British Archaeology North West *Archaeology North West* should be produced. This should be sent to the editor of *Archaeology North West* in time for it to appear within a calendar year of the completion of fieldwork.

## **13. Further Details**

- 13.1 Any queries about the contents of the specification should be addressed to the Specialist Advisor (Archaeology), Lancashire County Archaeology Service, Lancashire County
-

---

Council Environment Directorate, Guild House, Cross Street, Preston PPR1 8RD Tel 01772 531550, fax 01772 533423

Peter Iles  
Specialist Advisor (Archaeology)  
E-mail: [peter.iles@env.lancscc.gov.uk](mailto:peter.iles@env.lancscc.gov.uk)

**28 June 2005**



---

## APPENDIX 2: PROJECT DESIGN

---

**Oxford  
Archaeology  
North**

**July 2007**

### **CLITHEROE CASTLE, LANCASHIRE**

### **ARCHAEOLOGICAL BUILDING INVESTIGATION PROJECT DESIGN**

***Proposals***

*The following project design is offered in response to a request by Turner and Townsend, for a building investigation in advance of the development of the Museum and Sound Archive buildings, Clitheroe Castle.*

---

---

## 1. INTRODUCTION

- 1.1 **Project Background:** Clitheroe Castle is situated at the southern end of Clitheroe town (centred at SD 7424 4169), and has been described as ‘the strongest, the oldest, and from its position one of the most remarkable of the fortresses of Lancashire’ (Clarke 1877, 397-8). It is a designated Scheduled Monument (SM 27747), which incorporates several structures, including Grade I and Grade II Listed Buildings, and is situated in both a Registered Park and Garden and Clitheroe Conservation Area.
- 1.2 The site incorporates a museum, itself a Listed Building, and a Stable Range which form an important element of a wide-ranging scheme of restoration and adaptation. In particular, it is proposed that the museum is extended, which will necessitate the erection of a new building. This project design details the methodology that is to be employed during the proposed building recording, and is intended to support an application for Scheduled Monument Consent. The work is in accordance with a project brief prepared by Lancashire County Council.
- 1.3 **Oxford Archaeology:** Oxford Archaeology (OA), which is an educational charity under the guidance of a board of trustees, has over 30 years of experience in professional archaeology, and can provide a professional and cost-effective service. We are the largest independent employer of archaeologists in the country (we currently have more than 200 members of staff), and can thus deploy considerable resources with extensive experience to any archaeological project. We have offices in Lancaster and Oxford, trading as Oxford Archaeology North (OA North), and Oxford Archaeology (OA) respectively, enabling us to provide a truly nationwide service. OA is an Institute of Field Archaeologists Registered Organisation (No 17). All work on the project will be undertaken in accordance with relevant professional standards, including:
- IFA’s *Code of Conduct*, (1999); *Code of Approved Practice for the Regulation of Contractual Arrangements in Field Archaeology*, (1999); *Standard and Guidance for Archaeological Evaluations*, (1999); *Standard and Guidance for Archaeological Watching Briefs*, (1999).
  - English Heritage’s *Management of Archaeological Projects (MAP2)*, 1991.
  - *The European Association of Archaeologists Principles of Conduct for Archaeologists Involved in Contract Archaeological Work* (1998).
- 1.4 OA North has considerable experience of the assessment, survey, building survey and excavation of sites of all periods. Of particular relevance are several excavations and evaluations undertaken at medieval castles in the North West, including those at Brougham, Piel and Pendragon in Cumbria, Bolton in North Yorkshire, and Lancaster in Lancashire. OA North also has considerable experience of undertaking evaluations and excavations of Scheduled Monuments, notably on Hadrian’s Wall. OA North also has extensive experience of the excavation of complex urban stratigraphy, notably from major excavations undertaken in the North at Carlisle, Newcastle, Lancaster, Chester, and Warrington, each of which involved the recording of complex stratigraphy of extensive Roman and medieval deposits.

## 3 METHOD STATEMENT

### 3.1 INTRODUCTION

- 3.1.1 Where the intervention is minimal it is required that only a photographic record is maintained, but those elements of the buildings that will be subject to more major interventions will require an English heritage Level 3 record. The areas requiring a level 3 record are as follows:
- South Facing Elevation at the south end of the Stable Range (Sound Archive) (Elevation 1 on Drawing 6210AL321).
  - North, west and south-facing elevations within the courtyard between the south end of the Stable Range (Sound Archive) and the Court House. This should exclude the modern lean to, but include the earlier wall behind (Elevations 2, 3 and 4 on Drawing 6210 AL(0)4322).
-

- 
- West-facing elevation of the Court House to the Archive Room. This is below the jettied out upper extension of the west-facing elevation (shaded section of Elevation 2 on drawing 6210AL(0) 322
  - Exposed faces of the western gate pillar at the north-eastern corner of the ward, as well as 3m of curtain wall immediately to its west
  - Southern elevation of the museum (Drawing 6210 AL 125)
  - Western side of the southernmost extension of the museum building (Shaded section on drawing 6210 Al 126).

### 3.2 PHOTOGRAPHIC SURVEY

- 3.2.1 **General Photography:** a photographic record will be produced utilising a 35mm camera to produce black and white negatives, medium format images of the principal elevations and a high-resolution digital camera (8 megapixels). The archive will comprise general shots of the buildings (both internal and external) and their surroundings, and detailed coverage of architectural features, which illustrate both function and phasing. All photographs will include a photographic scale. A full photographic index will be produced.
- 3.2.2 **Rectified Photography:** if it proves that the elevation drawings provided by the architect are of insufficient accuracy for the provision of the Level 3 elevation record of the principal elevations (*Section 3.1.1*), rectified photography will be taken to provide a basic face on record of these external elevations. The rectified photography would be undertaken by in-house survey specialists and will be undertaken in black and white using a medium format camera. Control for the rectified photography will be provided by reflectorless instrument, and will record the locations of clearly defined elements of structural detail rather than targets to prevent the need for physically accessing the walls. The photography will be output at an appropriate scale; it will be scanned into a computer and presented as a raster backdrop within AutoCAD. Where there is any distortion within the photographic base, the digital image will be subject to digital correction using Archis software to convert the images to fully rectified images. The corrected images will then be incorporated as a raster backdrop within AutoCad and the elevation drawings will be drawn up as a vector drawing from the rectified base.
- 3.2.3 If the elevation drawings are of sufficient accuracy to enable enhancement, then a series of photographs will be taken of the affected elevations using a medium format camera, although these will not be rectified.

### 3.3 PLAN SURVEY

- 3.3.1 Plans will be produced for all elements of structures requiring a Level 3 survey. This will comprise the following:

#### **Museum**

- Basement Plan
- Ground floor plan
- First floor plan
- Second floor plan

#### **Southern part of the Stable Range - Sound Archive / Court House**

- Ground floor plan
  - First floor plan
  - Second floor plan
-

- 
- 3.3.2 Architects plans of these buildings will be enhanced and annotated to show the form and location of any structural features of historic significance. It is assumed that the plans of the buildings will be of sufficient accuracy to allow for their enhancement, if not there will need to be a variation to the costs to facilitate a new instrument survey. The additional detail will be created by means of manual survey onto paper copies. The corrected drawings will be digitised into an industry standard CAD package (Autocad 2004) for the production of the final drawings.

### 3.4 ELEVATION SURVEY

- 3.4.1 Architects drawings of the elevations defined in *Section 3.1.1* will be enhanced and annotated to show the form and location of any structural features of historic significance. The additional detail will be created by means of manual survey onto paper copies. The corrected drawings will be digitised into an industry standard CAD package (Autocad 2004) for the production of the final drawings. The drawings will show all decorative and significant stonework, such as quoins, tracery, window and door surrounds, but will not show all stones.
- 3.4.2 If the architects elevations are of insufficient accuracy then the elevation drawings will be produced by rectified photography (*Section 3.2.2*).

### 3.5 CROSS SECTIONS

- 3.5.1 Where necessary for the understanding of the buildings it may be necessary to create cross sections through the museum and the Stable Range (Court House) by means of instrument survey. The cross sections, where required, will be recorded by use of a reflectorless total station. The reflectorless total station is capable of measuring distances to architectural detail by reflection from the surface of that detail element; consequently it does not require the placement of a prism on the detail. The survey will be undertaken with respect to a series of accurately surveyed control stations established by traverse around the outside of the buildings. The data from the instrument will be combined with the earlier survey base within a CAD system and output as a series of plots to enable further enhancement of the drawing by manual survey. The drawings will usually be produced at a scale of either 1:50 or 1:100. The final product of the survey will be a single digital ground plan of the whole site, and detail views of the individual areas will be provided as a separate drawing.

### 3.6 BUILDING DESCRIPTION AND ANALYSIS

- 3.6.1 ***Interpretation and Analysis:*** a visual inspection of the buildings will be undertaken utilising the OA North buildings proforma sheets. An outline description will be maintained to RCHME Level II-type survey. This level of recording is descriptive and will produce an analysis of the development and use of the building.

### 3.7 ARCHIVE/REPORT

- 3.7.1 ***Archive:*** the results of the fieldwork will form the basis of a full archive to professional standards, in accordance with current English Heritage guidelines (*The Management of Archaeological Projects, 2nd edition, 1991*) and the *Guidelines for the Preparation of Excavation Archives for Long Term Storage* (UKIC 1990). The project archive represents the collation and indexing of all the data and material gathered during the course of the project. The deposition of a properly ordered and indexed project archive in an appropriate repository is considered an essential and integral element of all archaeological projects by the IFA in that organisation's code of conduct.
- 3.7.2 The paper and finds archive for the archaeological work undertaken at the site will be deposited with the Museum of Lancashire, in accordance with guidelines for the long term storage of archaeological material (MGC 1992). This archive can be provided in the English Heritage Centre for Archaeology format, both as hard and digital copy. The archive will be deposited with the Museums Service within six months of the completion of the fieldwork.
- 3.7.3 ***Survey report:*** three bound copies of a written synthetic report will be submitted to the Client, and a further copy submitted to the Lancashire SMR. The report will include a copy of this project design, and indications of any agreed departure from that design. It will present, summarise, and interpret the results of the programme detailed above. It will include an historical background and a complete bibliography of sources from which data has been derived, and a list of further sources identified during the programme of work, but not examined in detail. It will include a full index of archaeological/architectural features identified in the course of the project, with an assessment of
-

---

the overall plan, form and function, together with appropriate illustrations, including detailed plans and sections indicating the locations of archaeological/architectural features. The report will present an analytical assessment of the architectural significance of the structures on the site and will assess the function of features and identify evidence for features that have been lost. It will present, on the basis of the physical evidence, an assessment of the historical development of the site.

- 3.7.4 Illustrative material will include archaeological annotated record drawings, which would include plans, elevations, cross sections (as appropriate), a location map, and also pertinent photographs. It can be tailored to the specific requests of the client (eg particular scales etc), subject to discussion. The report will include photographs of any significant features.
- 3.7.5 **Confidentiality:** all internal reports to the client are designed as documents for the specific use of the Client, for the particular purpose as defined in the project brief and project design, and should be treated as such. They are not suitable for publication as academic documents or otherwise without amendment or revision.

### **3.8 ACCESS**

- 3.8.1 Access to the site will be arranged via the client/main contractor.

### **3.9 HEALTH AND SAFETY**

- 3.9.1 OA has its own Health and Safety policy and OA will work closely with the main contractor to ensure that safety standards are met. A risk assessment will be prepared by OA North in advance of all stages of field work. All site procedures are in accordance with the guidance set out in the Health and Safety Manual compiled by the Standing Conference of Archaeological Unit Managers (3<sup>rd</sup> Edition, 1997). OA North will liaise with the client/main contractor to ensure all health and safety regulations are met.
- 3.9.2 If any element or part of the building is deemed to be unsafe then, this area will not be recorded as part of the present programme, except from the documentary sources or by remote survey (where possible).
- 3.9.3 OA North has professional indemnity to a value of £2,000,000, employer's liability cover to a value of £10,000,000 and public liability to a value of £15,000,000. Written details of insurance cover can be provided if required.
- 3.9.4 Normal OA North working hours are between 9.00 am and 5.00 pm, Monday to Friday, though adjustments to hours may be made to maximise daylight working time in winter and to meet travel requirements. It is not normal practice for OA North staff to be asked to work weekends or bank holidays and should the client require such time to be worked during the course of a project a contract variation to cover additional costs will be necessary.

## **4. MONITORING**

- 4.1 Monitoring of the project will be undertaken by the Lancashire County Archaeologist, Peter Iles. Access to the site for monitoring purposes will be afforded to the Lancashire County Archaeologist at all times.

## **5. WORK TIMETABLE**

- 5.1 The phases of work will comprise:
- 5.1.1 **Field Survey**  
15 days will be required for the field survey
- 5.1.2 **Archive and Reporting**  
20 days would be required to complete this element.
- 5.1.3 OA North can execute the project within two weeks receipt of written notice.

## **6. STAFFING**

---

- 
- 6.1 The project will be under the overall charge of **Jamie Quartermaine**, BA, Surv Dip, MIFA (OA North Senior Project Manager) to whom all correspondence should be addressed.
-

---

## ILLUSTRATIONS

---

### LIST OF FIGURES

- Figure 1: Site Location
- Figure 2: Site plan of Clitheroe Castle showing locations of elevations and cross-section drawings
- Figure 3: Clitheroe Castle Museum Basement
- Figure 4: Clitheroe Castle Museum ground floor plan
- Figure 5: Clitheroe Castle Museum first floor plan
- Figure 6: Clitheroe Castle Museum second floor plan
- Figure 7: Clitheroe Castle Museum south-west elevation of Museum (Elevation 5)
- Figure 8: Clitheroe Castle Museum north-west elevation of the Museum Extension (Elevation 6)
- Figure 9: South-west-facing section through the Museum building and Sound Archive block
- Figure 10: Clitheroe Castle Sound Archive and Court House ground floor plan
- Figure 11: Clitheroe Castle Sound Archive and Court House first floor plan
- Figure 12: Clitheroe Castle south-facing elevation of the Sound Archive (Elevation 1)
- Figure 13: Clitheroe Castle: north, west and south-facing elevations of the Court House
- Figure 14: Clitheroe Castle: west-facing elevation of the Court House / Sound Archive (Elevation 7)
- Figure 15: Exposed Faces of the western gate pillar at the north-east corner of the ward (Elevation 8)
- Figure 16: 1940 reproduction by A Langshaw of Clitheroe Castle sketch (1732)
- Figure 17: Clitheroe Castle by M Oddie, 1781
- Figure 18: Ordnance Survey 1847 First Edition 6" to 1 mile map
- Figure 19: Ordnance Survey 1886 First Edition 25" to 1 mile map
- Figure 20: Clitheroe Castle Museum ground floor phase plan
- Figure 21: Clitheroe Castle Sound Archive and Court House ground floor phase plan
- Figure 22: Clitheroe Castle Sound Archive and Court House first floor phase plan

### LIST OF PLATES

- Plate 1: General view of the ward facing south with the Museum building in the centre and the Court House on the right
- Plate 2: General view from the grounds towards the Museum facing south
- Plate 3: View past the Museum towards the Sound Archive and Court House
-

---

Plate 4: General view of the north-west elevation of the Museum

Plate 5: Difference in construction visible in the north-west elevation of the Museum

Plate 6: General view of the south-west end of the Museum

Plate 7: Buttresses and balcony at the base of the south-east elevation of the Museum

Plate 8: The porch at the front (north-east elevation) of the Museum

Plate 9: General view of the Museum roof looking north-east

Plate 10: General oblique view of the Sound Archive eastern elevation

Plate 11: General oblique view of the east side of the Court House

Plate 12: General view of the west side of the Court House and Sound Archive

Plate 13: The front (north-east) elevation of the Museum

Plate 14: Flight of steps at the north-east corner of the Museum

Plate 15: General view of the south-east elevation of the Museum

Plate 16: Blocked windows in the south face of the 'South-East Tower'

Plate 17: Quoins visible in the south-east elevation of the Museum

Plate 18: Blocked windows at basement level of the south-east elevation of the Museum

Plate 19: Steps allowing access to the balcony on the south-east elevation of the Museum

Plate 20: Doorway in to the basement in the Museum south-east elevation

Plate 21: Motif on one of the down spout brackets on the Museum south-east elevation

Plate 22: North-western side of the upper part of the Museum south-west elevation

Plate 23: South-eastern side of the upper part of the Museum south-west elevation

Plate 24: The west side of the south-west elevation of the Museum south extension

Plate 25: Walkway at the base of the Museum south-west elevation

Plate 26: East side of the south-west elevation of the Museum south extension

Plate 27: Blocked doors at the rear of the Museum building

Plate 28: Probable lavatories at the east end of the sunken walkway

Plate 29: East side of the sunken walkway

Plate 30: Possible blocked doorway in the north-west elevation of the Museum

Plate 31: **Room E001** - The Foyer in the Museum

Plate 32: Panels in **Room E001**

Plate 33: General view of **Room E002** facing west

Plate 34: General view of **Room E002** facing east

Plate 35: Doorway into **Room E002**

Plate 36: The fireplace in **Room E003**

Plate 37: General view of **Room E005**

Plate 38: Detail of the decorative cornice in **Room E005**

---



---

Plate 39: General view of **Room E006**

Plate 40: Fireplace in **Room E007**

Plate 41: Stone sink in **Room E008**

Plate 42: Fireplace in **Room E008**

Plate 43: Beam and mullion in **Room E008** illustrating cut-away section

Plate 44: Staircase in **Room E010a**

Plate 45: General view of **Room E011** facing south-west

Plate 46: General view of **Room E011** facing north-east

Plate 47: General view of **Room E012** facing south-west

Plate 48: View of the ceiling of **Room E012**

Plate 49: Fleuron in **Room E012**

Plate 50: Decorative frieze in **Room E012**

Plate 51: Fireplace in **Room E012**

Plate 52: Encaustic hearth tiles in **Room E012**

Plate 53: Fenestration in **Room L007**

Plate 54: Decorative ceiling in **Room L005**

Plate 55: Examples of doorways on the second floor of the Museum building

Plate 56: Display in **Rooms L009** and **L010**

Plate 57: General view of **Room U008**

Plate 58: The fireplace in **Room U009**

Plate 59: The fireplace in **Room U006**

Plate 60: Gas fitting in **Room U005**

Plate 61: Roof space above **Room U002**

Plate 62: Communication pulleys

Plate 63: Northern room of the basement

Plate 64: Shelving in the basement

Plate 65: Steps from the basement which once led to **Room E010b**

Plate 66: Main entrance into the Sound Archive

Plate 67: The south-facing elevation of the Sound Archive

Plate 68: The small courtyard in between the Sound Archive and Court House

Plate 69: The east-facing elevation (Elevation 3) of the small courtyard

Plate 70: The lower part of Elevation 4 in the small courtyard

Plate 71: **Room L109** in the Sound Archive

Plate 72: Window in **Room L109** in the Sound Archive

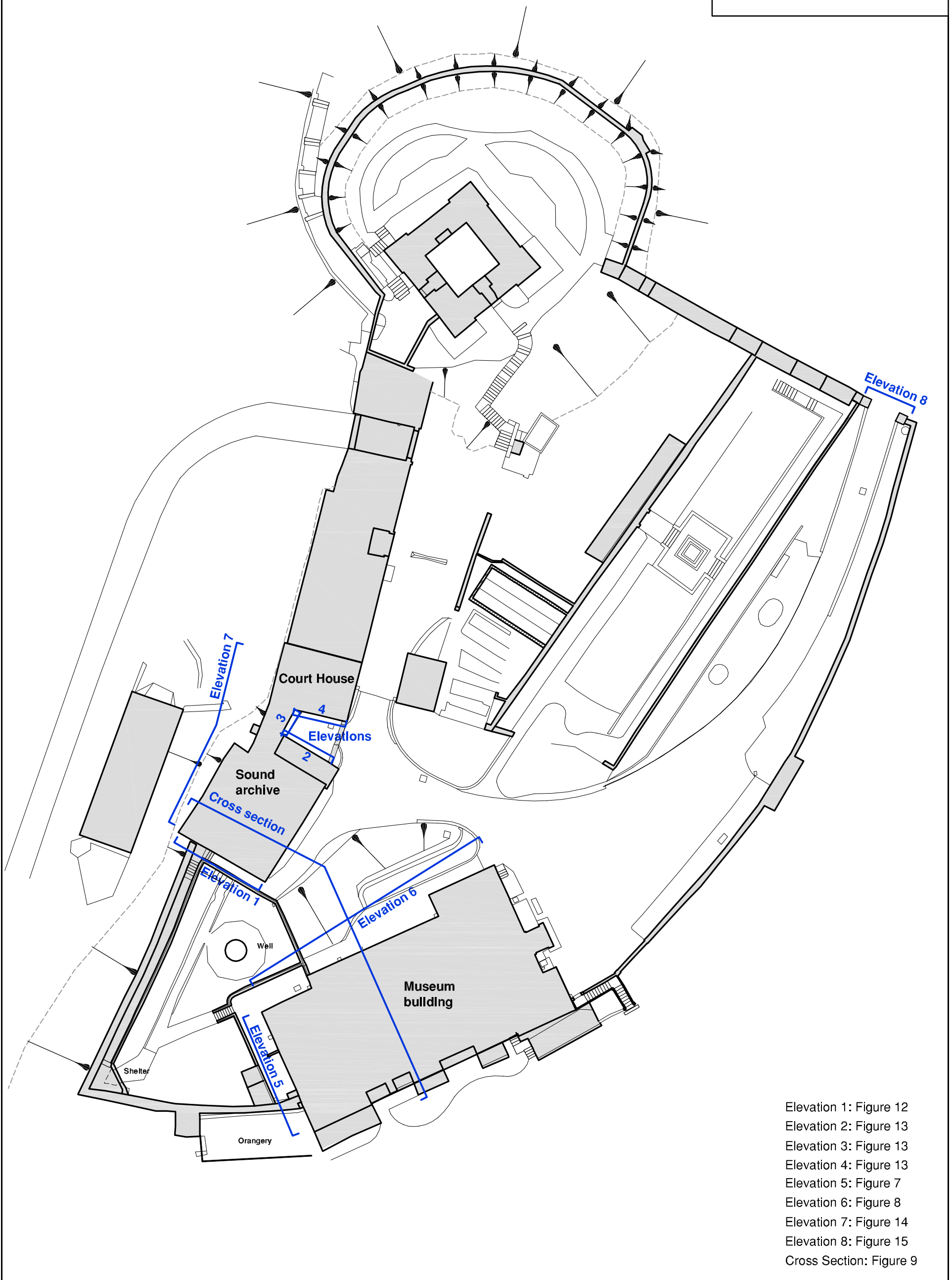
Plate 73: Detail of the Window in **Room L109** in the Sound Archive

---

- 
- Plate 74: Doorway in **Room L109** of the Sound Archive
- Plate 75: Fireplace in **Room L109** of the Sound Archive
- Plate 76: **Room L108** in the Sound Archive
- Plate 77: **Room L110** facing south
- Plate 78: Blocked window in the west wall of **Room L110**
- Plate 79: Windows in **Room L111** of the Court House
- Plate 80: General view of **Room L104** of the Sound Archive facing east
- Plate 81: Oak staircase in **Rooms L106/U104** of the Sound Archive
- Plate 82: Room **L107** of the Sound Archive
- Plate 83: Cast-iron beam in **Room L107** of the Sound Archive
- Plate 84: Corbel and base of truss in **Room U102** of the Sound Archive
- Plate 85: North side of **Room U101** of the Sound Archive
- Plate 86: South side of **Room U101** of the Sound Archive
- Plate 87: Ventilation opening in **Room U105** of the Sound Archive
- Plate 98: View of **Room U106** facing south
- Plate 89: Window in **Room U106**
- Plate 90: Iron door surround in **Room U106**
- Plate 91: General view of **Room U107** of the Court House
- Plate 92: Heating grille in the floor of **Room U107** of the Court House
- Plate 93: The west window in **Room U107** of the Court House
- Plate 94: The east window in **Room U107** of the Court House
- Plate 95: The north wall of the Court House from within **Room L116**
- Plate 96: **Room L114** of the Court House facing west
- Plate 97: Toilets in **Room L112** of the Court House
- Plate 98: The 'Samson Wash-Down Closet' in **Room L112** of the Court House
- Plate 99: The Gateposts facing south
- Plate 100: Example of the plinth at the base of the post, together with remnant of the gate hinges
- Plate 101: Detail of the top of the posts
-


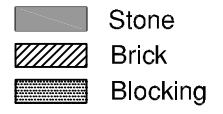



Figure 1: Site location



- Elevation 1: Figure 12
- Elevation 2: Figure 13
- Elevation 3: Figure 13
- Elevation 4: Figure 13
- Elevation 5: Figure 7
- Elevation 6: Figure 8
- Elevation 7: Figure 14
- Elevation 8: Figure 15
- Cross Section: Figure 9

Figure 2: Site plan of Clitheroe Castle showing location of elevations and cross-section drawings


  

  

  
 1:125 @ A3

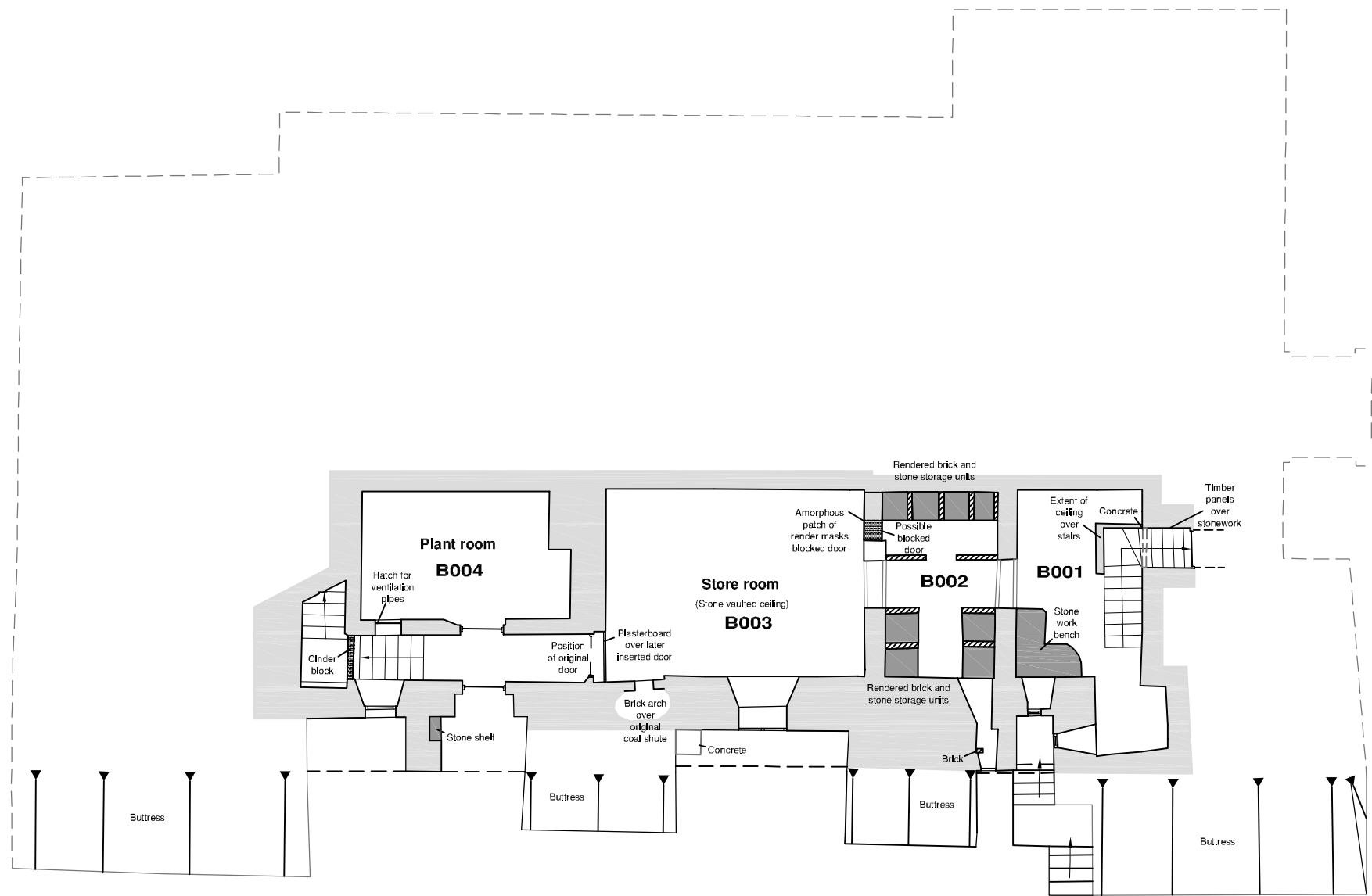


Figure 3: Clitheroe Castle Museum basement



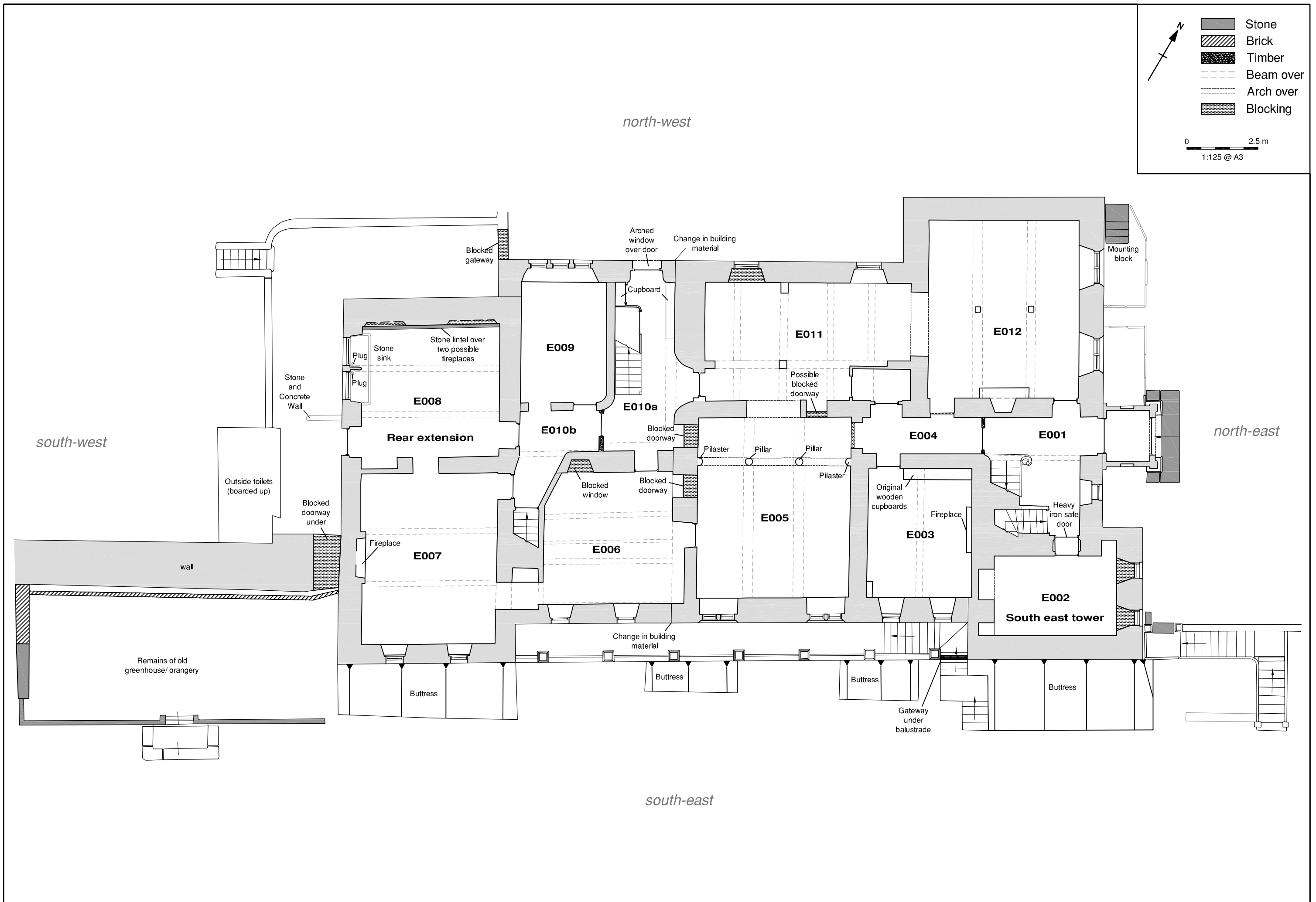


Figure 4: Clitheroe Castle Museum ground floor plan

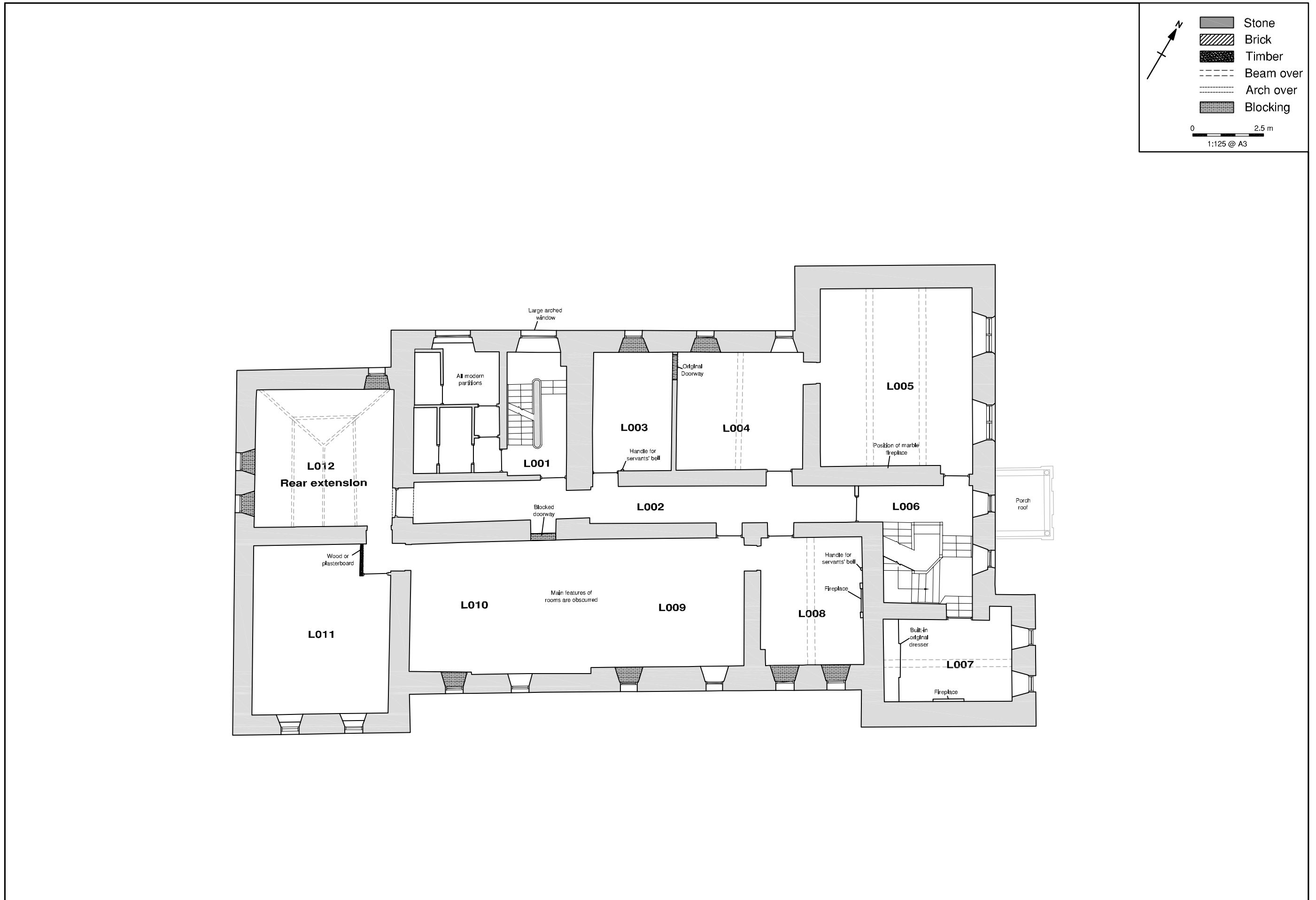










Figure 5: Clitheroe Castle Museum first floor plan





-  Stone
-  Brick
-  Timber
-  Beam over
-  Arch over
-  Blocking

 0 2.5 m  
 1:125 @ A3

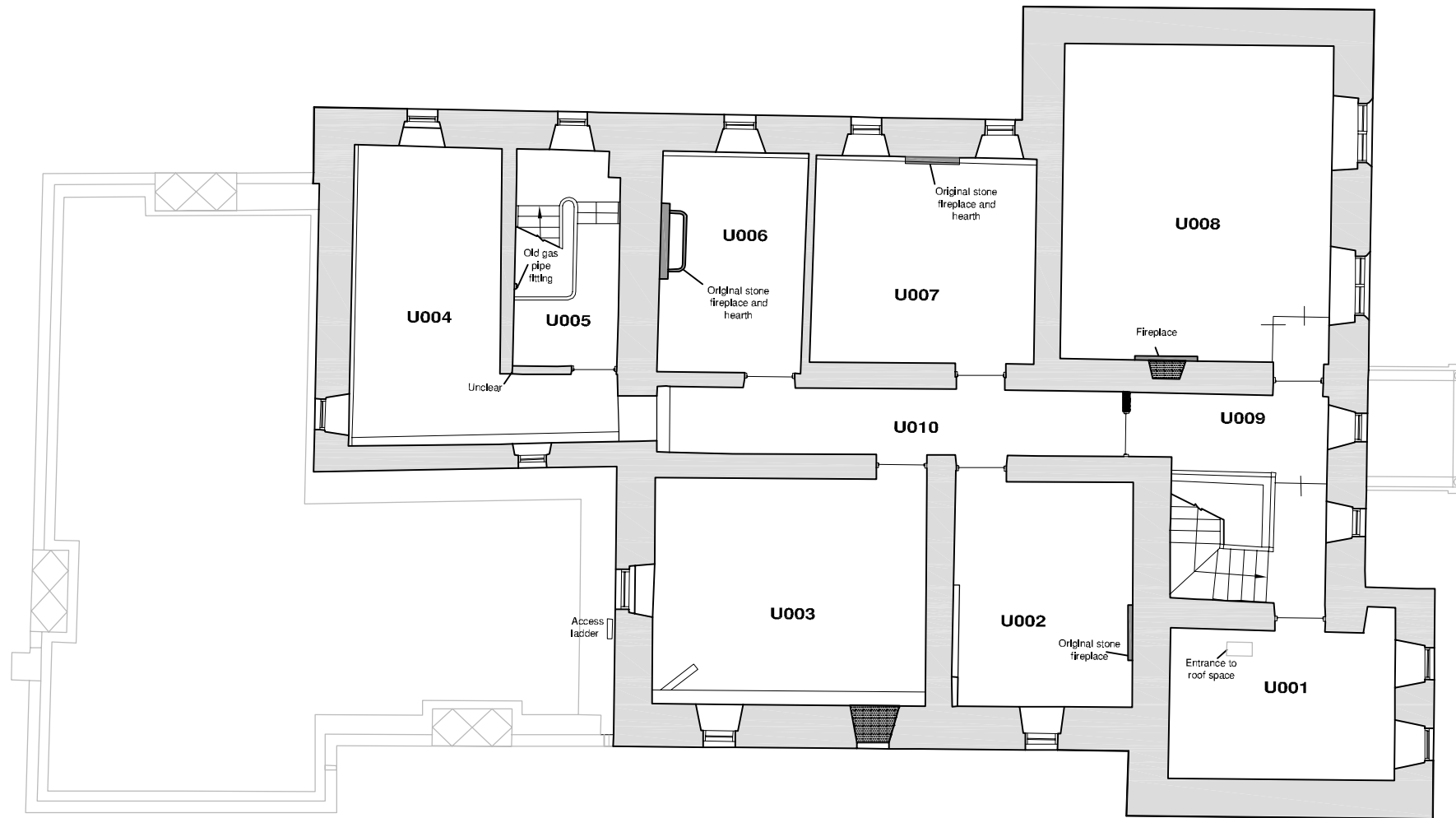


Figure 6: Clitheroe Castle Museum second floor plan







Figure 7: Clitheroe Castle south-west elevation of Museum (elevation 5)

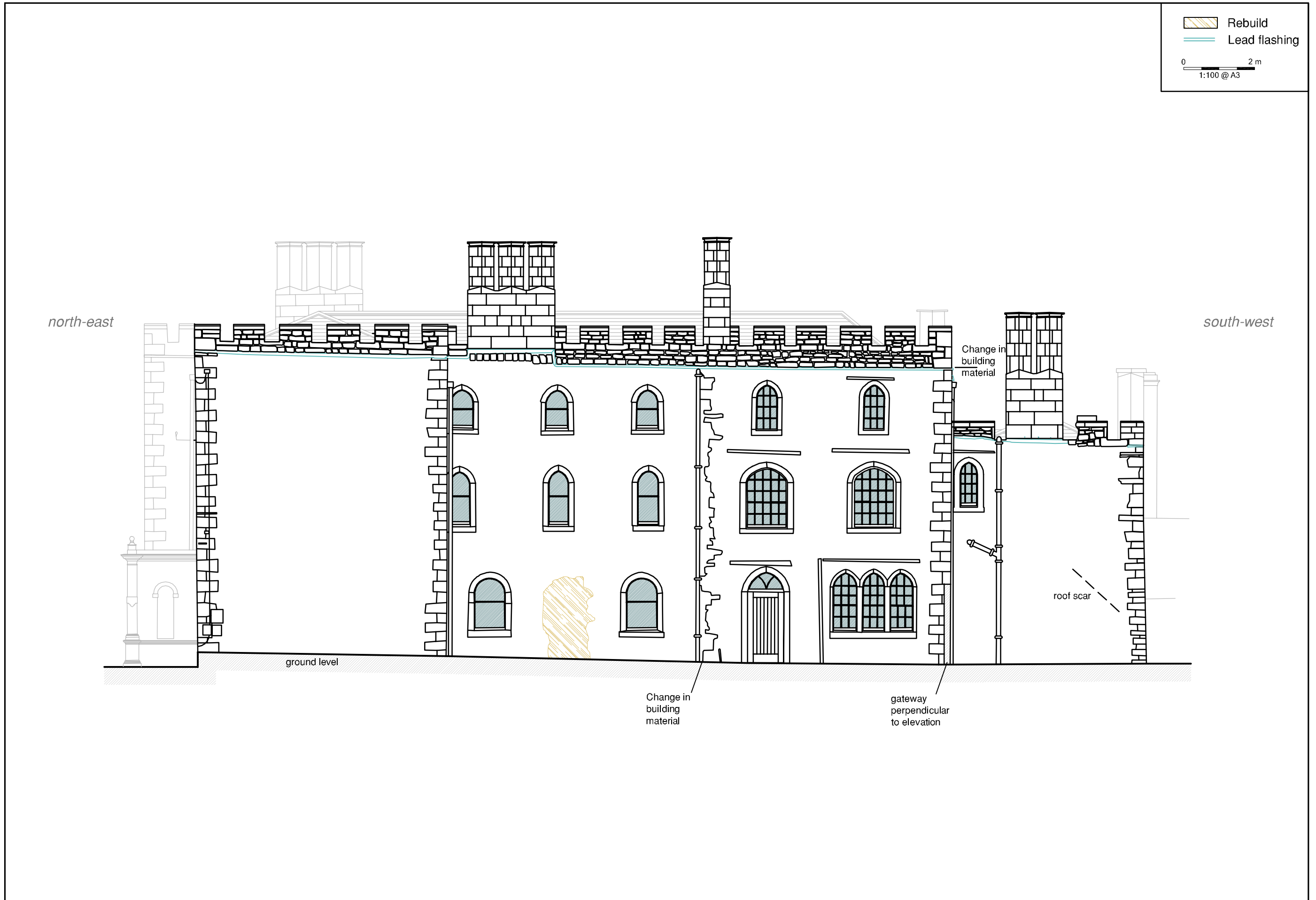


Figure 8: Clitheroe Castle West elevation of the museum extension (elevation 6)

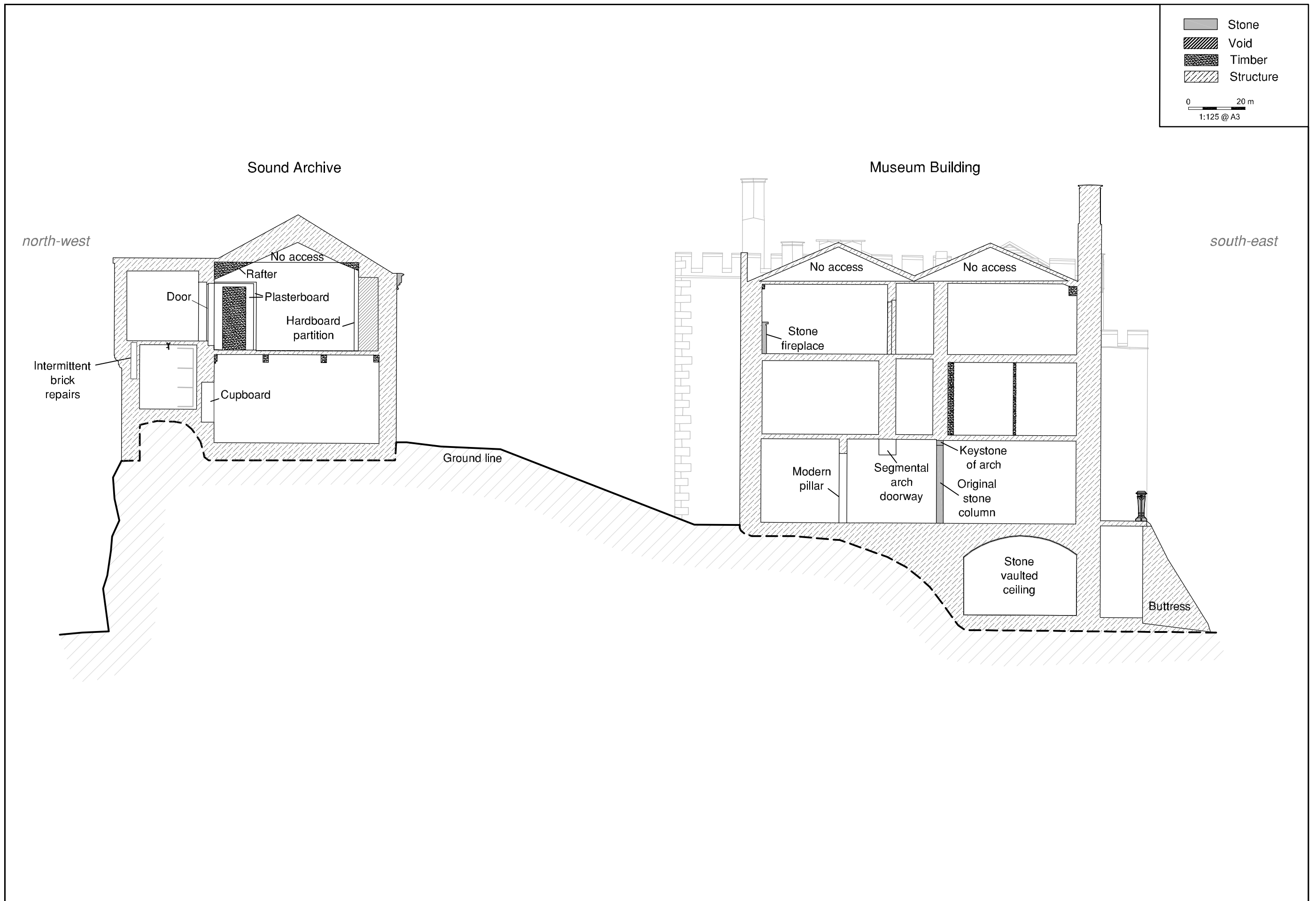


Figure 9: Clitheroe Castle, south-west facing cross-section through the Museum building and Sound Archive block

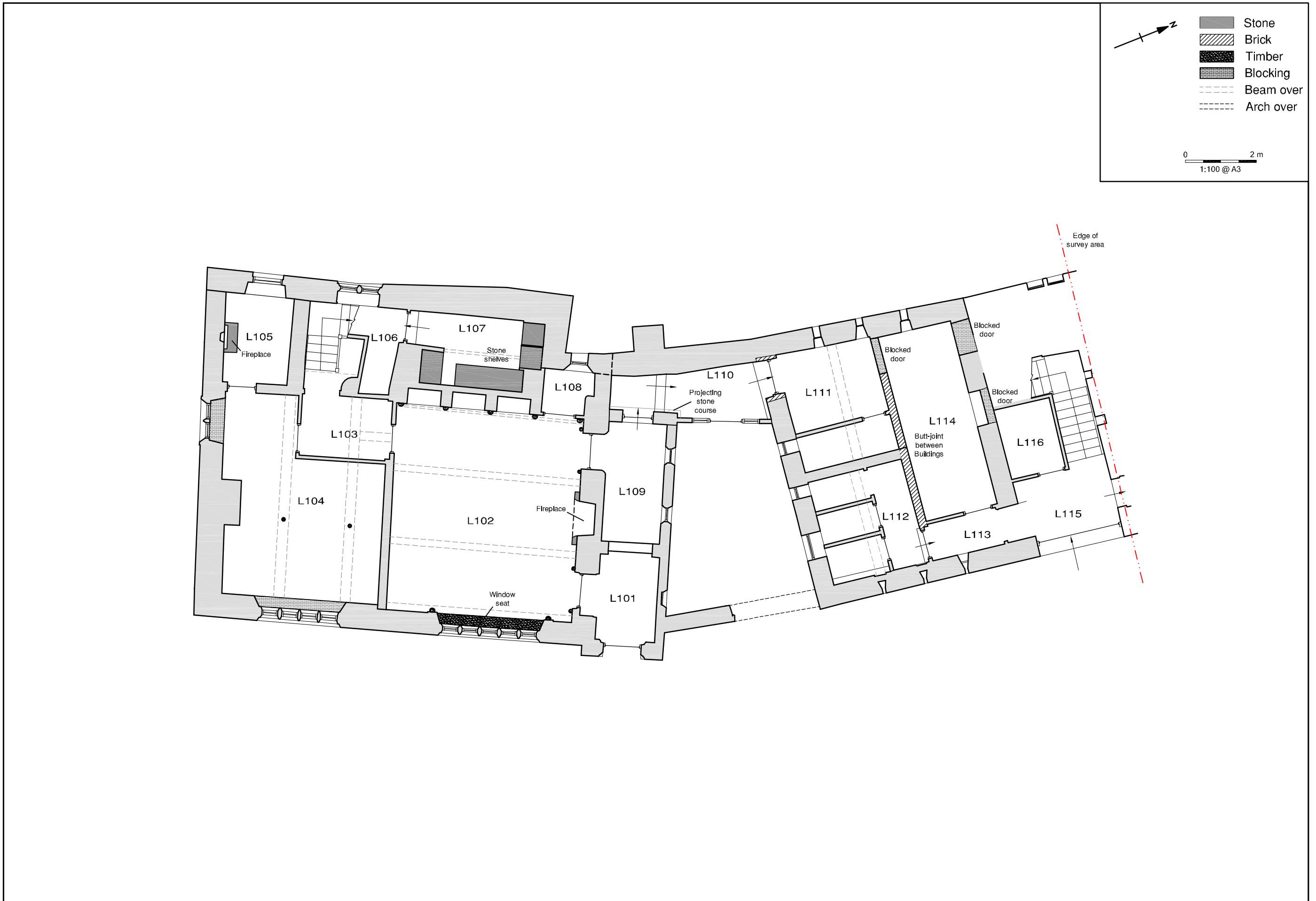


Figure 10: Clitheroe Castle Sound Archive and Court House ground floor plan

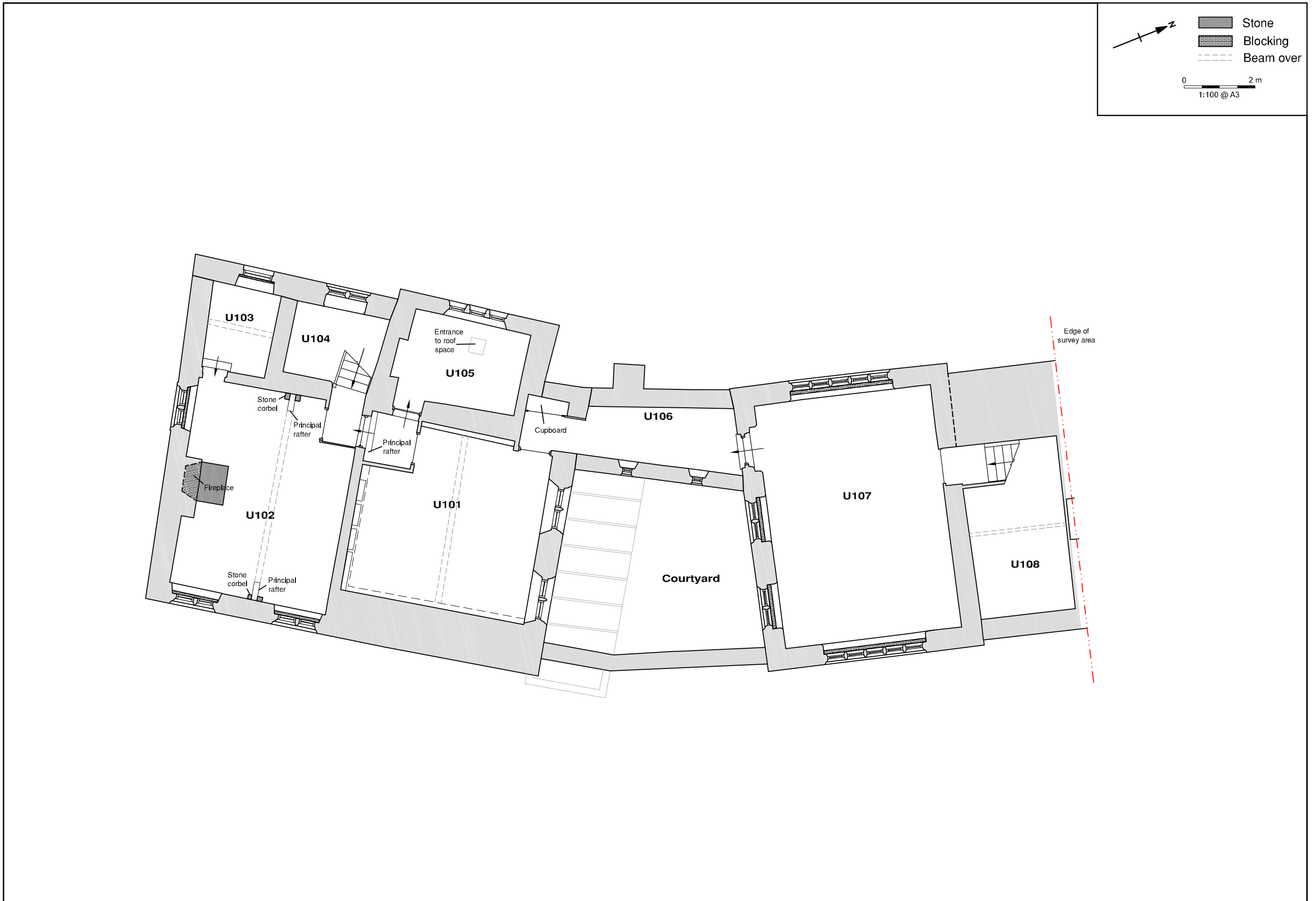


Figure 11: Clitheroe Castle Sound Archive and Court House first floor

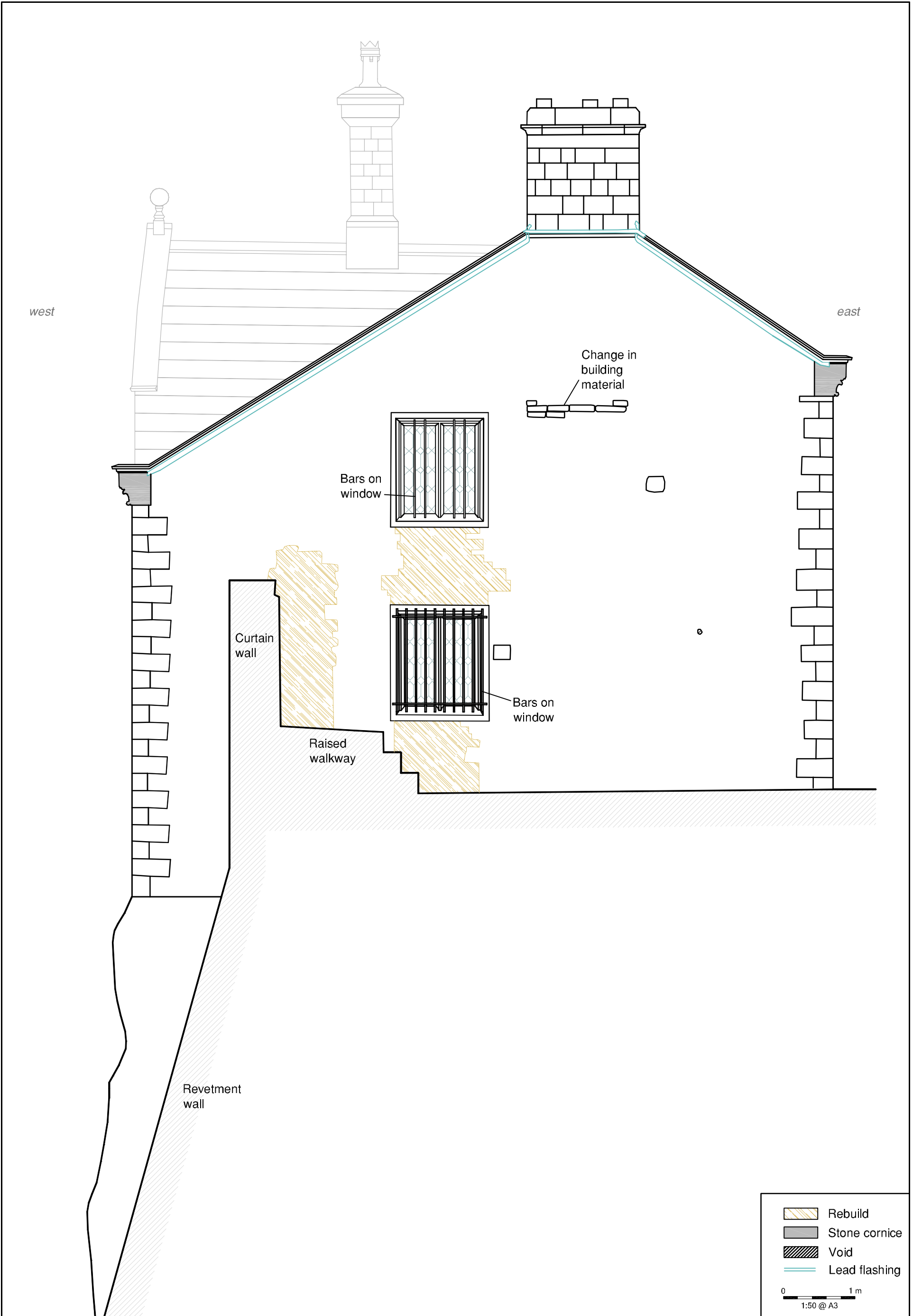


Figure 12: Clitheroe Castle; south-facing elevation of the Sound Archive (elevation 1)

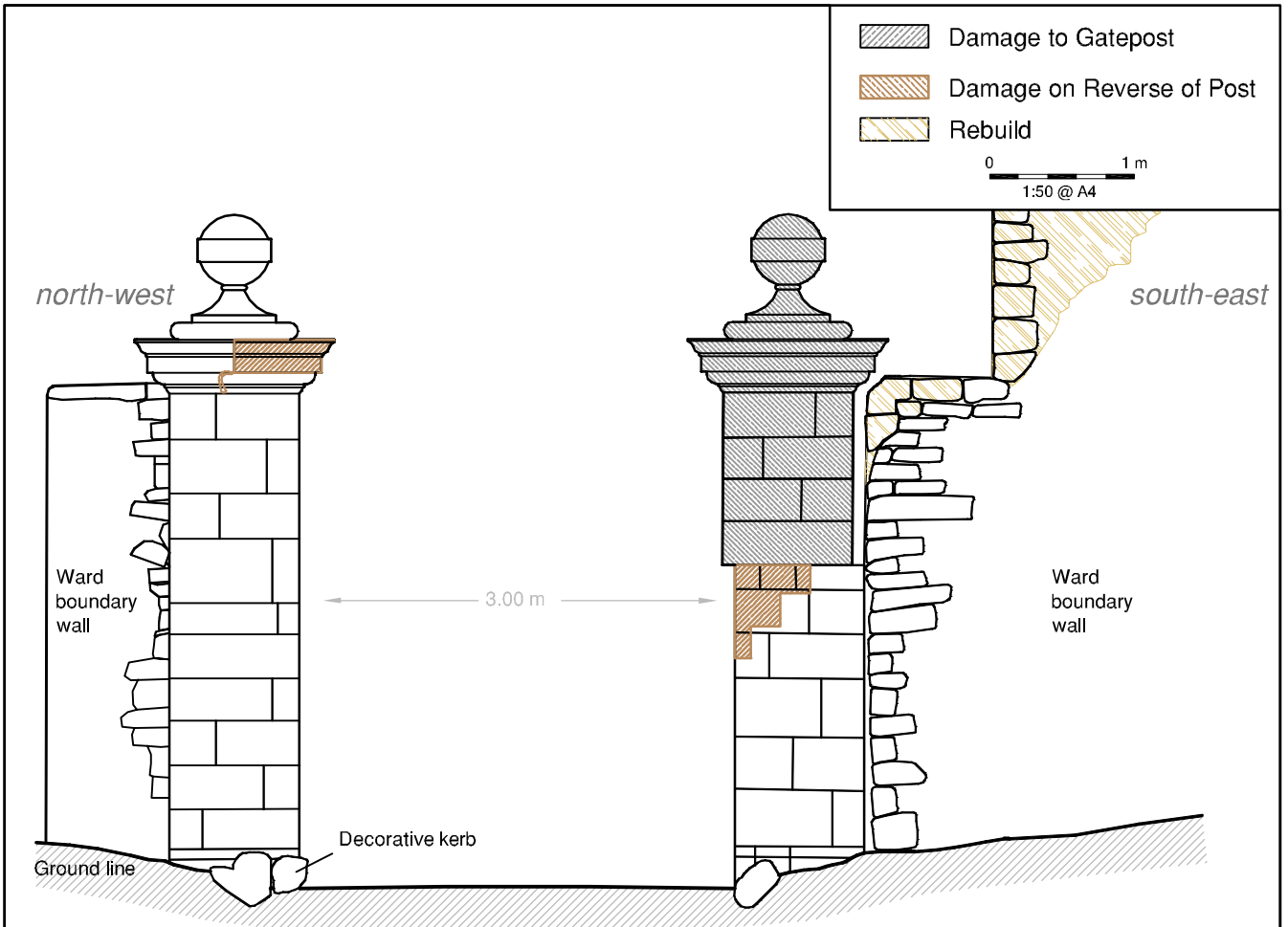


Figure 13: Clitheroe Castle north-, west- and south-facing elevations of the Court House (elevations 2, 3 and 4)

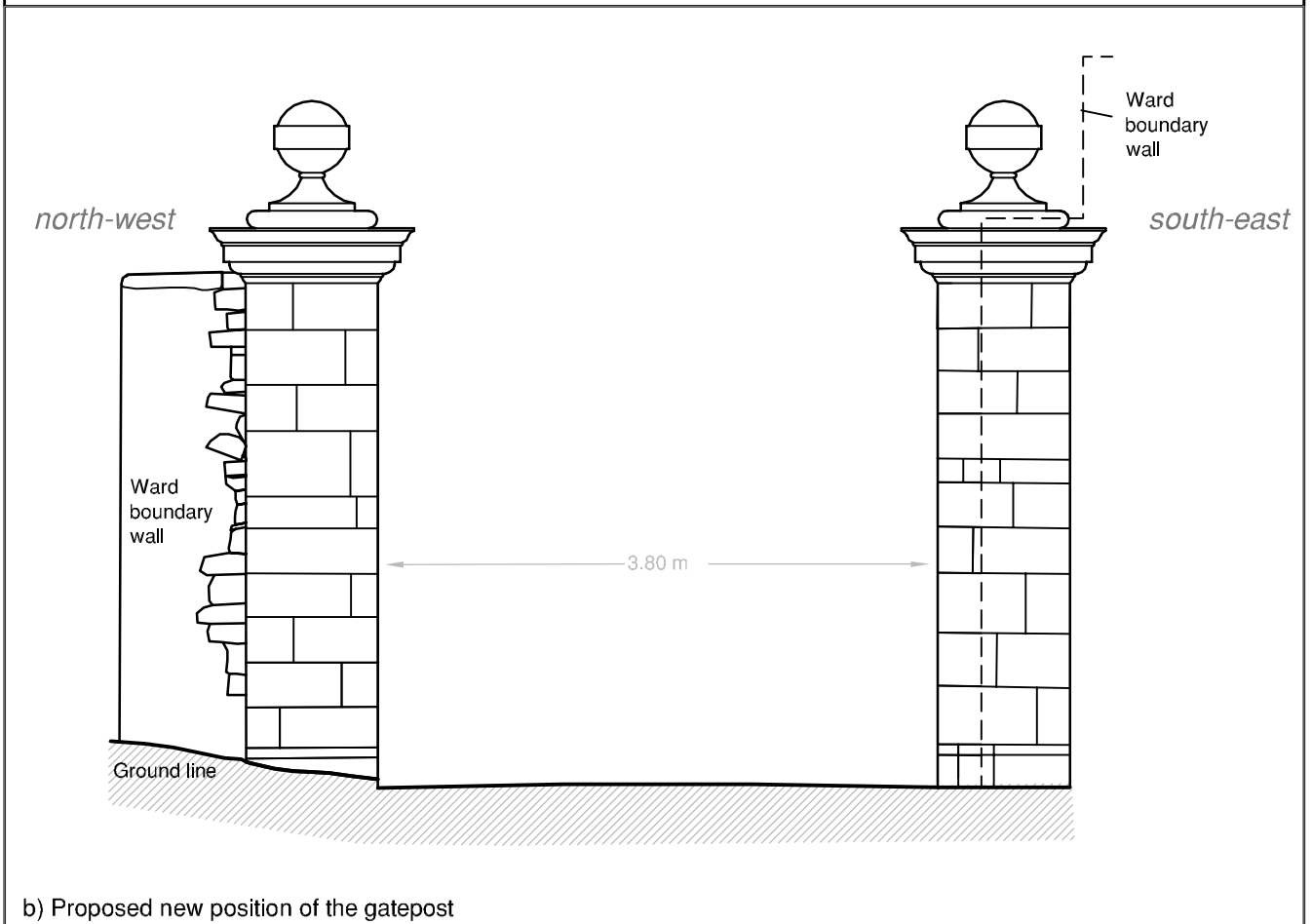


Figure 14: Clitheroe Castle west-facing elevation of the Court House/ Sound Archive (elevation 7)





a) Original position of the gatepost showing areas of damage



b) Proposed new position of the gatepost

Figure 15: Exposed faces of the western gate pillar at the north-east corner of the ward (elevation 8)



Prospect of Clitheroe Castle from the South (1723).

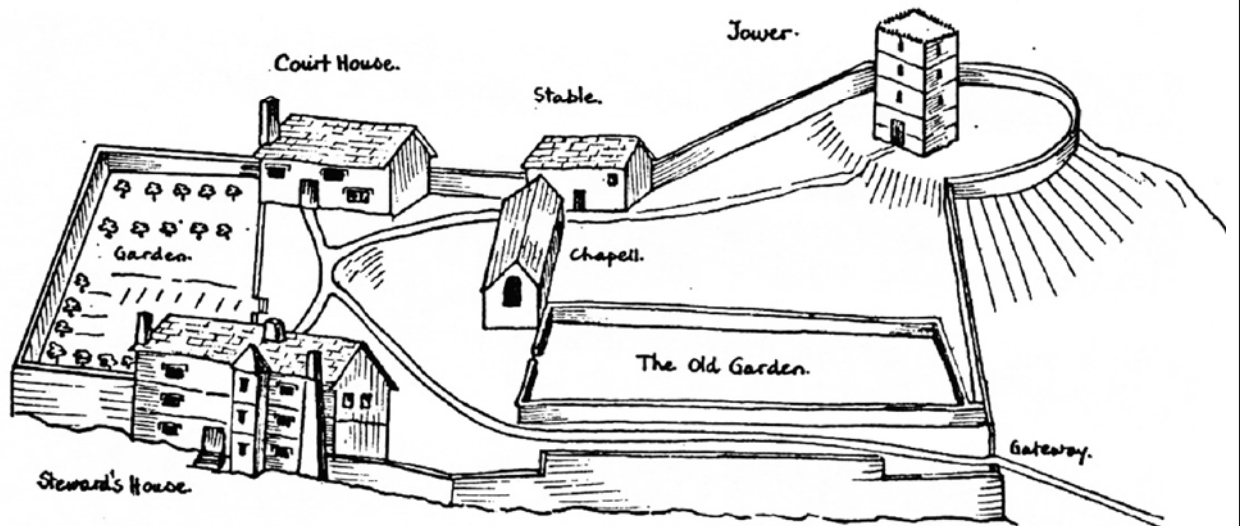


Figure 16: 1940 reproduction of Clitheroe Castle sketch by A. Langshaw (1732)

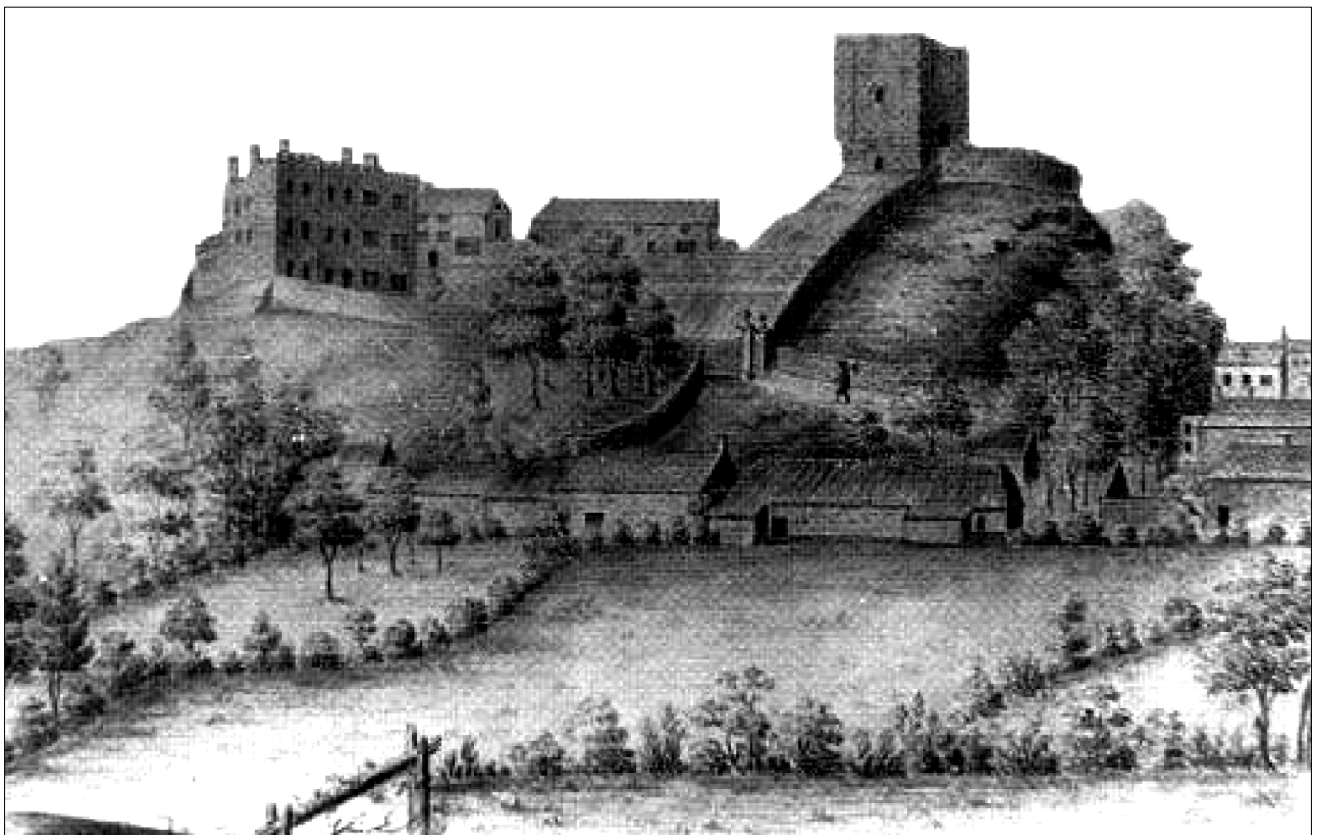


Figure 17: Clitheroe Castle by M Oddie, 1781



Figure 18: Ordnance Survey 1847 First Edition 6" to 1 mile map



Figure 19: Ordnance Survey 1886 First Edition 25" to 1 mile map

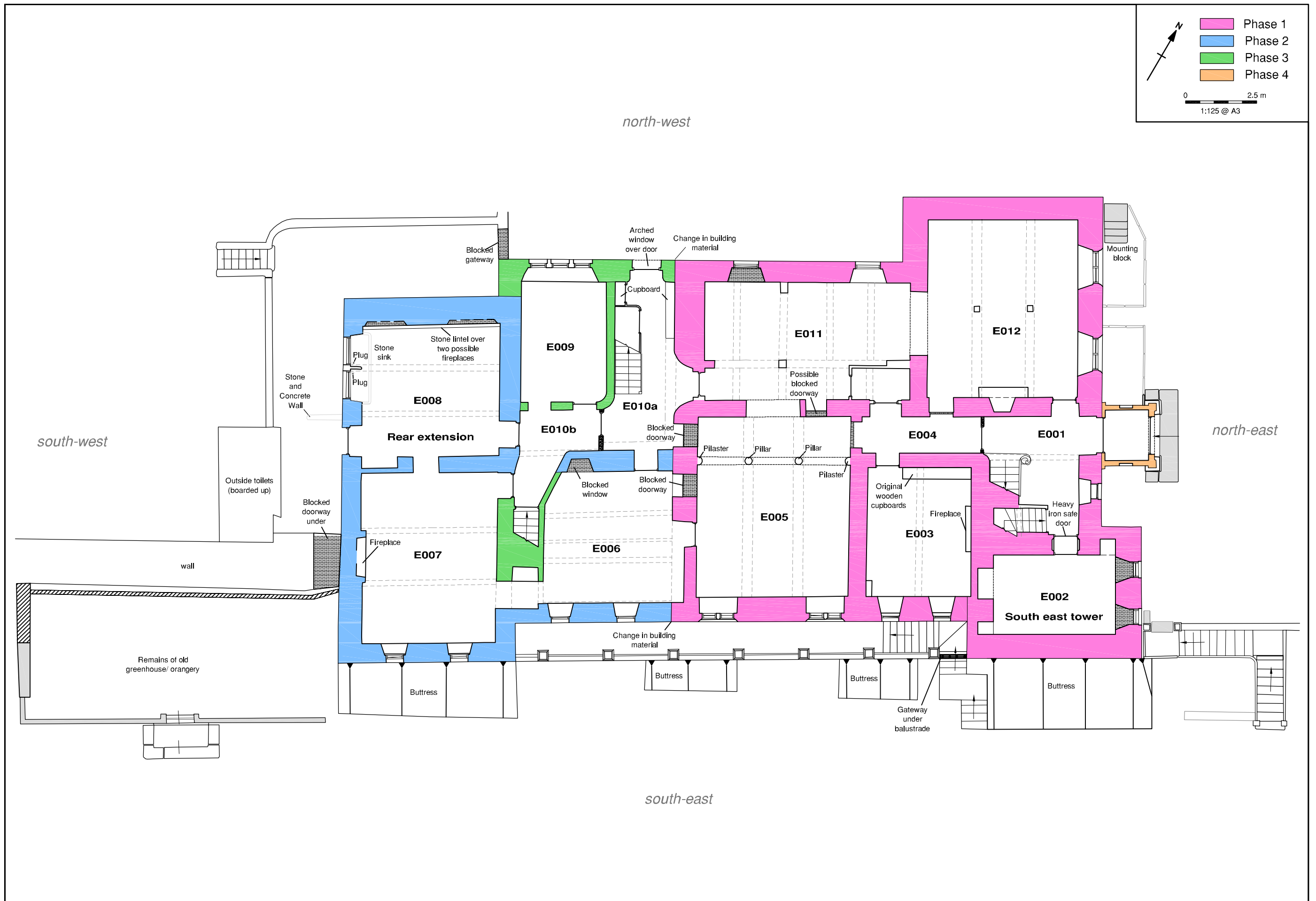


Figure 20: Clitheroe Castle Museum ground floor phase plan

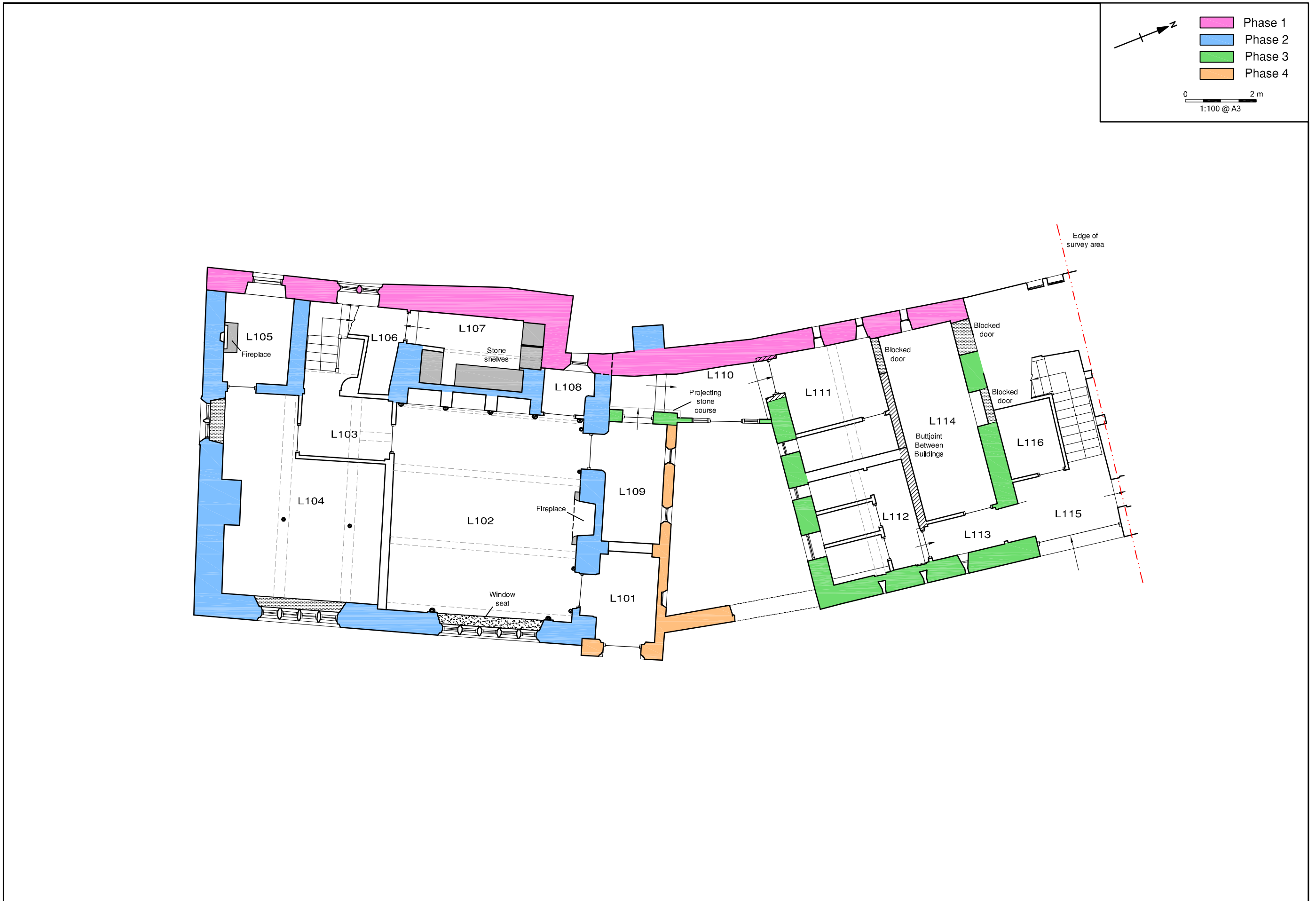


Figure 21: Clitheroe Castle Sound Archive and Court House ground floor phase plan



Figure 22: Clitheroe Castle Sound Archive and Court House first floor phase plan



Plate 1: General view of the ward, facing south with the Museum building in the centre and the Court House on the right



Plate 2: General view from the grounds towards the Museum facing south



Plate 3: View past the museum towards the Sound Archive and Court House



Plate 4: General view of the north-west elevation of the Museum





Plate 5: Difference in construction visible in the north-west elevation of the Museum



Plate 6: General view of the south-west end of the Museum



Plate 7: Buttresses and balcony at the base of the south-east elevation of the Museum



Plate 8: The porch at the front (north-east elevation) of the Museum



Plate 9: General view of the Museum roof looking north-east



Plate 10: General oblique view of the Sound Archive eastern elevation



Plate 11: General oblique view of the east side of the Court House



Plate 12: General view of the west side of the Court House and Sound Archive



Plate 13: The front (north-east) elevation of the Museum



Plate 14: Flight of steps at the north-east corner of the Museum



Plate 15: General view of the south-east elevation of the Museum



Plate 16: Blocked windows in the south face of the 'South-East Tower'



Plate 17: Quoins visible in the south-east elevation of the Museum



Plate 18: Blocked windows at basement level of the south-east elevation of the Museum



Plate 19: Steps allowing access to the balcony on the south-east elevation of the Museum



Plate 20: Doorway in to the basement in the Museum south-east elevation





Plate 21: Motif on one of the down spout brackets on the Museum south-east elevation



Plate 22: North-western side of the upper part of the Museum south-west elevation



Plate 23: South-eastern side of the upper part of the Museum south-west elevation



Plate 24: The west side of the south-west elevation of the Museum south extension



Plate 25: Walkway at the base of the Museum south-west elevation



Plate 26: East side of the south-west elevation of the Museum south extension



Plate 27: Blocked doors at the rear of the Museum building



Plate 28: Probable lavatories at the east end of the sunken walkway



Plate 29: East side of the sunken walkway



Plate 30: Possible blocked doorway in the north-west elevation of the Museum



Plate 31: **Room E001** - The Foyer in the museum



Plate 32: Panels in **Room E001**



Plate 33 General view of **Room E002** facing west



Plate 34 General view of **Room E002** facing east



Plate 35 Doorway into **Room E002**



Plate 36 The fireplace in **Room E003**





Plate 37 General view of **Room E005**



Plate 38 Detail of the decorative cornice in **Room E005**



Plate 39: General view of **Room E006**



Plate 40: Fireplace in **Room E007**



Plate 41: Stone sink in **Room E008**



Plate 42: Fireplace in **Room E008**



Plate 43: Beam and mullion in **Room E008** illustrating cut-away section



Plate 44: Staircase in **Room E010a**



Plate 45: General view of **Room E011** facing south-west



Plate 46: General view of **Room E011** facing north-east



Plate 47: General view of **Room E012** facing south-west



Plate 48: View of the ceiling of **Room E012**



Plate 49: Fleuron in **Room E012**



Plate 50: Decorative frieze in **Room E012**



Plate 51: Fireplace in **Room E012**



Plate 52: Encaustic hearth tiles in **Room E012**





Plate 53: Fenestration in **Room L007**



Plate 54: Decorative ceiling in **Room L005**



Plate 55: Examples of doorways on the second floor of the Museum building



Plate 56: Display in **Rooms L009 and L010**



Plate 57: General view of **Room U008**



Plate 58: The fireplace in **Room U009**



Plate 59: The fireplace in **Room U006**



Plate 60: Gas fitting in **Room U005**



Plate 61: Roof space above **Room U002**



Plate 62: Communication pulleys



Plate 63: Northern room of the basement



Plate 64: Shelving in the basement



Plate 65: Steps from the basement which once led to **Room E010b**



Plate 66: Main entrance into the Sound Archive



Plate 67: The south-facing elevation of the Sound Archive



Plate 68: The small courtyard in-between the Sound Archive and Court House





Plate 69: The east-facing elevation (Elevation 3) of the small courtyard



Plate 70: The lower part of Elevation 4 in the small courtyard



Plate 71: **Room L109** in the Sound Archive



Plate 72: Window in **Room L109** in the Sound Archive



Plate 73: Detail of the Window in **Room L109** in the Sound Archive



Plate 74: Doorway in **Room L109** of the Sound Archive



Plate 75: Fireplace in **Room L109** of the Sound Archive



Plate 76: **Room L108** in the Sound Archive



Plate 77: **Room L110** facing south



Plate 78: Blocked window in the west wall of **Room L110**



Plate 79: Windows in **Room L111** of the Court House



Plate 80: General view of **Room L104** of the Sound Archive facing east



Plate 81: Oak staircase in **Rooms L106/U104** of the Sound Archive



Plate 82: Room **L107** of the Sound Archive



Plate 83: Cast-iron beam in **Room L107** of the Sound Archive



Plate 84: Corbel and base of truss in **Room U102** of the Sound Archive





Plate 85: North side of **Room U101** of the Sound Archive



Plate 86: South side of **Room U101** of the Sound Archive



Plate 87: Ventilation opening in **Room U105** of the Sound Archive



Plate 88: View of **Room U106** facing south



Plate 89: Window in **Room U106**



Plate 90: Iron door surround in **Room U106**



Plate 91: General view of **Room U107** of the Court House



Plate 92: Heating grille in the floor of **Room U107** of the Court House



Plate 93: The west window in **Room U107** of the Court House

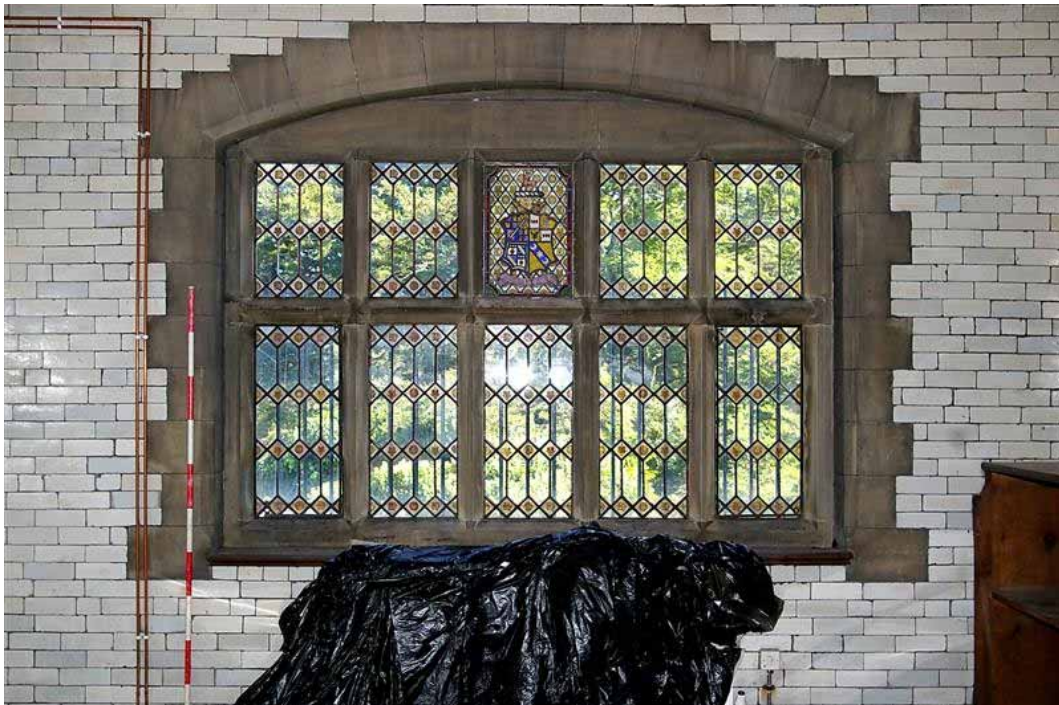


Plate 94: The east window in **Room U107** of the Court House



Plate 95: The north wall of the Court House from within **Room L116**



Plate 96: **Room L114** of the Court House facing west



Plate 97: Toilets in **Room L112** of the Court House



Plate 98: The 'Samson Wash-Down Closet' in **Room L112** of the Court House



Plate 99: The Gateposts facing south



Plate 100: Example of the plinth at the base of the post, together with remnant of the gate hinges





Plate 101: Detail of the top of the posts