

# CFA Archaeology Ltd

*archaeological consultants*

*Advice on Archaeology & Planning*

*Environmental Impact Assessment*

*Interpretation, Design & Display*

*Finds/ Environmental Analysis*

*Field Evaluation & Excavation*

*Historic Building Recording*

*Site & Landscape Survey*

*Geophysical Survey*

**1 Kilwinning Street, Musselburgh,  
East Lothian**

**Archive Assessment  
and Evaluation**

**Report No. 1978**

## **CFA ARCHAEOLOGY LTD**

The Old Engine House  
Eskmills Business Park  
Musselburgh  
East Lothian  
EH21 7PQ

Tel: 0131 273 4380  
Fax: 0131 273 4381  
email: [info@cfa-archaeology.co.uk](mailto:info@cfa-archaeology.co.uk)  
web: [www.cfa-archaeology.co.uk](http://www.cfa-archaeology.co.uk)

|                         |                                      |
|-------------------------|--------------------------------------|
| Author                  | Leigh A. Garst BFA MSc               |
| Illustrator             | Kevin Hicks BA FSA Scot              |
| Editor                  | Melanie Johnson MA PhD FSA Scot MifA |
| Commissioned by         | Hackland + Dore Architects Limited   |
| Date issued             | December 2011                        |
| Version                 | 0                                    |
| Planning Application No | 11/00604/P                           |
| Grid Ref                | NT 3459 7265                         |
| OASIS Ref               | cfaarcha1-115311                     |

This document has been prepared in accordance with CFA Archaeology Ltd standard operating procedures.

**1 Kilwinning Street, Musselburgh,  
East Lothian**

**Archive Assessment  
and Evaluation**

**Report No. 1978**

## **CONTENTS**

|    |                        |   |
|----|------------------------|---|
| 1. | Introduction           | 3 |
| 2. | Working Methods        | 4 |
| 3. | Archaeological Results | 5 |
| 4. | Conclusion             | 8 |

## **Appendices**

|    |  |    |
|----|--|----|
| 1. | Context Register                           | 9  |
| 2. | Drawing Register                           | 10 |
| 3. | Photographic Register                      | 11 |
| 4. | Discovery and Excavation in Scotland Entry | 12 |

## **Illustrations (bound at rear)**

Fig. 1 Site and Trench Location

Fig. 2a Musselburgh 1893, Ordnance Survey extract

Fig. 2b Musselburgh 1893, Ordnance Survey extract

Fig. 3 Trench 1 plan

Fig. 4 The eastern end of Trench 1 from the WNW

Fig. 5 Trench 2 plan

Fig. 6 The eastern end of Trench 2 from the WNW

# **1. INTRODUCTION**

## **1.1 General**

This report presents the results of an archive assessment and archaeological evaluation undertaken by CFA Archaeology Ltd (CFA) in November 2011 at 1 Kilwinning Street, Musselburgh, East Lothian (Fig. 1). The work was commissioned by Hackland + Dore Architects Limited.

A Written Scheme of Investigation (WSI) dated 06 October 2011 was produced by CFA and approved by East Lothian Council Archaeology Service (ELCAS) prior to the fieldwork.

## **1.1 Background**

The site of the proposed development is situated within the historic core of the medieval town of Musselburgh, which had received burgh status by AD 1184. The earliest documentary sources for the town (Royal Charters dating to the 11th and 12th centuries) indicate that Musselburgh was probably already well established by the mid-12th century. The proposed development is located behind the shops and flats, Numbers 72-90, which front onto the High Street. They therefore lie within the original medieval burgage plots (Fig. 2a and 2b).

As with other excavations in medieval burghs, archaeological remains can survive in these areas and therefore a programme of archaeological work was required before any construction-related ground-breaking works. From cartographic evidence it appeared that the proposed development area had not seen significant development since at least the mid 19<sup>th</sup> century, suggesting that there may be survival of archaeological remains.

## **1.2 Aims and Objectives**

The project's aims and objectives were:

- To determine the presence or absence, location, extent, date, character, condition, significance and quality of any surviving archaeological remains liable to be threatened by the proposed development.
- To propose mitigation measures where necessary.

## **2. WORKING METHODS**

### **2.1 General**

CFA Archaeology Ltd follows the Institute for Archaeologists' Code of Conduct, Standards and Guidance.

### **2.2 Archive Assessment**

Historic map coverage for the area was examined together with other available cartographic information on pre-recent land use in the development area. The National Monuments Record of Scotland (NMRS), the East Lothian Council Sites and Monuments Record (SMR), the Statutory List of Buildings of Special Architectural or Historic Interest and the Inventory of Gardens and Designed Landscapes (through Pastmap) were consulted to obtain information on known archaeological sites within the proposed development area.

### **2.3 Evaluation**

Three trenches with a total area of 59m<sup>2</sup> were excavated in the area of the proposed development. The trenches were excavated using a wheeled JCB mechanical excavator equipped with a smooth-bladed ditching bucket under constant archaeological supervision. Any further excavation required to fulfil the objectives of the evaluation was carried out by hand.

Trench positions were constrained due to the presence of upstanding buildings and overhead utility services.

All excavation and on-site recording was carried out according to standard CFA procedures, principally by drawing, by photography and by completing standard CFA record forms.

All trenches were backfilled after the archaeological works had been completed.

### 3. ARCHAEOLOGICAL RESULTS

#### 3.1 Archive Assessment

##### *NMRS Sites*

The NMRS does not list any sites within the development area. The closest recorded sites are early 19<sup>th</sup> century buildings fronting the High Street. These include a Public House (Numbers 72-74, NT37SW 96) alternatively known as The Inn Place or The Grey Horse, Shop Fronts (Numbers 76 (NT37SW 95), 78-80 (NT37SW 997), 82-84 (NT37SW 998) and 88-90 (NT37SW 999)) and a tenement building (Number 86 NT37SW 94). All are Category C-Listed. The earliest site recorded was a chapel (NT37SW 49) dedicated to St. James which once stood between the plots now occupied by the public house 74 and store front 76.

##### *Cartographic Sources*

The earliest map consulted was Taylor and Skinner's map of 1776, which depicts development in the area around the High Street with agricultural plots behind. There is insufficient detail to allow the development area to be accurately pinpointed.

The earliest map to show the proposed development area in detail is the First Edition Ordnance Survey map of 1854 (surveyed 1852-53). Kilwinning Street itself does not appear until the Ordnance Survey map of 1944 (surveyed 1938).

The most useful historical maps are the 1853 (Fig. 2a) and 1893 (Fig. 2b) Musselburgh Town Plans. The 1853 plan shows roofed buildings and what may be yards within the northern part of the development area. The southern part appears to contain gardens as both trees and paths are depicted. Roofed buildings are less clearly depicted on the 1893 plan but the division apparent from the earlier map is repeated. The representation of steps within the plot behind 82-84 High Street suggests the buildings to the north are well below the level of the gardens to the south.

#### 3.2 Evaluation

Machine excavation in both trenches removed a gravel surface (**100**, **200** and **301**) c. 0.1m in thickness. Concrete in the west end of Trench 2 was broken using a hydraulic hammer. All three trenches revealed deep stratigraphy.

Numbers in bold in the following text refer to contexts, a full list of which is contained in Appendix 1.

##### *Trench 1*

Trench 1 measured 18m in length by 1.5m wide and was orientated roughly west to east (Figs. 1-3).

Structural remains were found in the eastern end of the trench (Figs. 3-4). The remains of two parallel sandstone walls (**110**) and (**114**) of similar construction and size were found running north-south and disappeared into the baulk beyond the trench

limits. Running at an angle from underneath (114) was a second sandstone rubble wall (107) with a clay damp-proofing layer (108) running along its south side. Between wall (107) and the northern trench edge were demolished sandstone blocks (116) overlying paving stones (115). No occupation deposits were present.

Another sandstone wall (118) with clay damp-proofing on the northern side (117) could just be seen in the north-facing section of the trench. To the east, a linear ditch (106) running north-south was discovered, filled with soft brown silty sand (112) with 19<sup>th</sup> century finds including brick, bone, pantile, stone and lead in the fill. The ditch continued beyond the trench limits. Immediately east of the ditch (106) the stub of a sandstone wall (105) without obvious mortar-bonding was found.

The stratigraphic layers within the trench varied slightly. At the west end below the gravel surface (100), the made ground consisted of red blaes and stones (102), followed by dark brown/black silty sand (103) under which mid brown silty sand with soot/charcoal inclusions overlay the natural sandy gravel substrate (003). To the east, there were the three upper layers of 100, 102 and 103 followed by light brown silt with stone chips and mortar (111) between wall (113) and ditch (106), and orangey-brown sand overlying wall (113) up to wall (110).

### *Trench 2*

Trench 2 measured 14m in length with a maximum width of 2.1m orientated roughly west to east (Figs. 1-3).

Structural remains in Trench 2 were more varied than Trench 1 (Figs. 5-6). The remains of a set of parallel sandstone walls (208 and 217) were found running north-south and these appear to connect with (114) and (110) found in Trench 1.

Wall (212) abuts wall (208) on the north-facing trench section and runs through (as 213) to the second plot boundary wall 217. An internal sandstone wall 210 was recorded, with a degraded wooden post (211) in the corner formed by walls 212 and 210. The area to the north of wall 212/213 and on either side of wall 210 was paved with rounded cobbles (209, 214). Very large quantities of finds including many complete bottles, crockery, tins, tyres and plastic rubbish were present within these structures.

To the east of wall 213, a short flight of 4 cut-stone steps (216) abutted wall (217). A door check (215) was identified on the east end of the top step.

To the east of wall 217, a mortared stone wall (219) continued east towards the edge of the trench, slightly curving to the north. Immediately to the north of wall (219) a stone-lined well (222) was found. This had sandstone lintels (221) largely obscuring the interior.

The stratigraphic layers within the trench varied dramatically. At the west end under modern concrete, the layers of made ground consisted of yellowish-brown sand with stone chips (201) over black silty sand (205), and dark brown silty sand with soot/charcoal inclusions (206) over mid yellowish brown silty sand (224). The natural substrate (003) was a yellow gravelly sand. Over the middle of the trench where the

architectural remains were present the top layer of gravel (200) was followed by mixed blaes and black silt (203), red and pink blaes (204) and demolition rubble (207). At the eastern end of the trench over the well (222) and wall 219, the gravel (200) was underlain by black silt and gravel (218).

### *Trench 3*

Trench 3 measured 7m in length with a maximum width of 1.5m orientated south-west to north-east (Fig. 1).

Trench 3 was excavated in the north-east corner of the development area. Below surface gravel (301) was a layer of mixed demolition rubble and blaes (302) which overlay a grey-black soil (303). This overlay a deep deposit of yellow-brown sandy soil (304) which merged into natural sands (003) at a depth of 2.4m.

No structural remains were present and there were no negative features.



#### 4. CONCLUSIONS

An archaeological evaluation was carried out by CFA Archaeology Ltd at 1 Kilwinning Street, Musselburgh, East Lothian. Three trenches covered 59m<sup>2</sup> of the development site.

The evaluation demonstrated that the heavily truncated remains of boundary walls and the interior walls of buildings or yards exist at a depth of around 0.5m below current ground level. Some of these appear to represent structures present on the 1853 and 1893 Ordnance Survey Musselburgh Town Plans. The remains identified included boundary walls, external and internal building walls, wooden internal fittings, cobbled and paved stone floors, stone steps and a well.

In terms of where the structural remains were located, no remains were recorded in the plots to the rear of Numbers 72-76 and Numbers 86-90 High Street; these plots contained deep soil horizons. All of the building remains lay in the plots to the rear of Numbers 78-84 High Street.

In Trench 1, the north-south aligned boundary walls are shown on both the 1853 and 1893 Town Plans. The structural remains in the east of the trench underlie the western boundary wall and are not shown on these maps but appear to be the remains of a building or buildings. No finds were recovered and the date of these structure(s) is unknown. They are however bisected and possibly cut by a ditch containing 19th-century finds.

In Trench 2, the north-south aligned boundary walls are shown on both the 1853 and 1893 Town Plans. A roofed building is shown in the west of the trench in 1853 but there was no trace of this structure in the trench. To the east, an unroofed building or yard is shown on the 1853 map. All of the remains are shown on the 1893 Musselburgh Town Plan and the steps provide a very useful reference point for the whole trench. These remains do not appear to represent a roofed building, notwithstanding the presence of a door check. The well in the east of the trench is not shown on either map but the curve of the wall to the south of the well is shown in both 1853 and 1893.

In Trench 3, deep soils were recorded. No archaeological remains were present and none are shown on historic maps.

No pre-modern finds were recovered during the fieldwork.

The decision regarding further mitigation work lies with the East Lothian Council Archaeology Service.

The project archive, comprising all CFA record sheets, maps and reports, will be deposited with the National Monuments Record of Scotland (NMRS) and copies of reports will be lodged with the East Lothian Sites and Monuments Record.

A summary statement of the results of this evaluation will be submitted for publication in *Discovery and Excavation in Scotland* (Appendix 4) and an online OASIS form will be completed.

## APPENDIX 1: Context Register

| Context no. | Trench         | Fill of | Description  |
|-------------|----------------|---------|--|
| 003         | Trench 1 and 2 |         | Natural gravelly sand  |
| 100         | Trench 1       |         | Surface Gravel- c. 0.1m Depth Across Trench  |
| 101         | Trench 1       |         | Red Blaes and Stones- c.0.2m-0.4m Depth Across Trench  |
| 102         | Trench 1       |         | Dark Brown/Black Silty Sand- c. 0.2m-0.5m Depth Across Trench  |
| 103         | Trench 1       |         | Mid Brown Silty Sand and Black Lenses- c. 0.55m Depth Across the First 8.5m of the E End of the Trench                                 |
| 105         | Trench 1       |         | Wall of Medium-Large Sub-Angular Sandstone Build Mortar on Upper Surfaces- 1.10m Length x 0.95m Width x 0.20m Height                   |
| 106         | Trench 1       |         | Cut for N-S Linear Ditch- 1.50m Length x 1.25m Width x 0.90m Depth   |
| 107         | Trench 1       |         | Wall of Sandstone Rubble and Mortar Running E-W Under 112- 2.75m Length x 0.56m Width x 0.3m Height                                    |
| 108         | Trench 1       |         | Yellowish-Grey Gritty Clay Damp Proofing to S of Wall 107- 2.80m Length x 0.35m Width  |
| 109         | Trench 1       |         | Concrete to E of Wall 110- 1.5m in Length x 1.0m Width Extends Beyond Trench Limits  |
| 110         | Trench 1       |         | Wall of Sandstone Build Running N-S Between High St.- Unknown Length x 0.50m Width x 0.45 Height                                       |
| 111         | Trench 1       |         | Light Brown Sandy Silt with Stone Chips and Mortar- 3.35m Length x 0.9m Width x 0.7m Depth   |
| 112         | Trench 1       | 106     | Dark Brown/Black Silty Sand Containing 19th Century Finds- 1.50m Length x 1.25m Width x 0.9m Depth                                     |
| 113         | Trench 1       |         | Orangey-Brown Sand Over Wall 105- 3.2m Length x 1.5m Width x 0.6m Depth  |
| 114         | Trench 1       |         | Wall of Sandstone Build Running N-S Between High St.- Unknown Length x 0.50m Width x 0.28 Height                                       |
| 115         | Trench 1       |         | Paving to N of Wall 107- 1.06m Length x 0.38m Width x 0.09m Depth  |
| 116         | Trench 1       |         | Sandstone Blocks with Mortar and Silt- 0.98m Length x 0.29m Width x 0.22m Depth  |
| 117         | Trench 1       |         | Yellowish-Grey Gritty Clay Damp Proofing to N of Wall 118 in the N Facing Section of Trench- 1.2m Length x 0.12m Width x Unknown Depth |
| 118         | Trench 1       |         | Sandstone Wall in N Facing Section- 1.74 Length x Width and Height Unknown   |
| 200         | Trench 2       |         | Surface Gravel- c. 0.1m Depth Across Trench  |
| 201         | Trench 2       | 202     | Yellowish-Brown Sand and Stone Chips Below Concrete- 2.10m Length x 1.5m Width x 0.19m Depth   |
| 202         | Trench 2       |         | Modern Cut- 2.10 Length x 1.5m Width x 0.19m Depth   |
| 203         | Trench 2       |         | Mixed Blaes and Black Silt Over Wall 208-  |
| 204         | Trench 2       |         | Red and Pink Blaes- 7.20m Length x 1.5m Width x c. 0.3m Depth  |
| 205         | Trench 2       |         | Black Firm Silty Sand Silt- 2.10m Length x 1.5m Width x 0.14m Depth  |
| 206         | Trench 2       |         | Dark Brown Silty Sand with Black Lenses- 2.10 Length x 1.5m Width x 0.28m Depth  |
| 207         | Trench 2       |         | Demolition Rubble- 6.8m Length x 1.5m Width x c. 0.4m Depth  |
| 208         | Trench 2       |         | Boundary and Building Wall of Sandstone Build Continues N and S- 1.52m Length x 0.62m Width x 0.7m Height                              |
| 209         | Trench 2       |         | Floor of Medium Rounded Cobbles- 2.68m Length x 2.10m Width x Unknown Depth  |

| Context no. | Trench   | Fill of | Description   |
|-------------|----------|---------|---|
| 210         | Trench 2 |         | Internal Stone Mortared Building Wall- Continues N and S- 1.68m Length x 0.30m Width x 0.4m Height        |
| 211         | Trench 2 |         | Degraded Wooden Post- 0.06m Width x 0.4m Depth  |
| 212         | Trench 2 |         | Southern Wall of Building to W- 2.7m Length x Unknown Width x 0.1m Height                                 |
| 213         | Trench 2 |         | Southern Wall of Building to E- 3.60m Length x Unknown Width x 0.66m Height                               |
| 214         | Trench 2 |         | Floor of Medium Rounded Cobbles- 2.50m Length x 1.65m Width x Unknown Depth                               |
| 215         | Trench 2 |         | Cut Stone Door Check- 0.29m Length x 0.25m Width 0.49 Height  |
| 216         | Trench 2 |         | Cut Stone Steps W of 217- 1.24m Length x 1.0m Width 0.60m Height  |
| 217         | Trench 2 |         | Boundary and Building Wall of Sandstone Build Continues N and S- 1.70m Length x 0.60m Width x 1.1m Height |
| 218         | Trench 2 |         | Black Silt and Gravel- 2.82m Length x 1.5m Width x 0.2m Depth   |
| 219         | Trench 2 |         | Mortared Stone Wall- 2.82m Continues E x 0.46m Width x Unknown Height                                     |
| 220         | Trench 2 |         | Mixed Silt, Stone Chips and Mortar- 1.46m Length x 1.49m Width x Unknown Depth                            |
| 221         | Trench 2 |         | Sandstone Lintel/Well Cover- c. 1.2m Length x 0.3m Width x Unknown Height                                 |
| 222         | Trench 2 |         | Well Wall of Mortared Sandstone Rubble- 1.15m Diameter x 1.5m Depth                                       |
| 223         | Trench 2 | 222     | Silt and Stones- 1.15m Diameter x Unknown Depth   |
| 224         | Trench 2 |         | Mid Yellowish Brown Soft Silty Sand and Black Lenses- 2.12m Length x 1.5m Width x c. 0.7m Depth           |
| 225         | Trench 2 |         | Black Silt and Very Large Quantities of Artefacts: Fill of Buildings 212, 213 Below 207                   |
| 301         | Trench 3 |         | Surface gravel  |
| 302         | Trench 3 |         | Spread of modern demolition debris and red blaes  |
| 303         | Trench 3 |         | Grey-black buried soil  |
| 304         | Trench 3 |         | Yellow-brown buried soil  |

## APPENDIX 2: Drawing Register

| Dwg No. | Sheet No. | Scale | Plan / Section | Description/contexts         |
|---------|-----------|-------|----------------|------------------------------|
| 1       | 1         | 1:20  | Section        | S Facing Section of Trench 1 |
| 2       | 2         | 1:20  | Plan           | Plan of Trench 1             |
| 3       | 3         | 1:20  | Section        | N Facing Section of Trench 2 |
| 4       | 4         | 1:20  | Plan           | Plan of Trench 2             |

### APPENDIX 3: Photographic Register

| Shot No. | Shot No.   | Taken from | Conditions   |
|----------|--|------------|--------------|
| 1-13     | Pre Ex View of the Site  | Various    | Dull         |
| 14-16    | Trench 1 Excavated   | E          | Overcast     |
| 17       | General View of Wall 105   | S          | Overcast     |
| 18       | Detailed Shot of Wall 105  | S          | Overcast     |
| 19       | Wall 105 and Ditch 106   | S          | Overcast     |
| 20       | Detailed Shot of Ditch 106 Section   | S          | Overcast     |
| 21       | Detailed Shot of Ditch 106 Section Bottom  | S          | Overcast     |
| 22-23    | Wall 107 and Clay Deposit 108  | S          | Overcast     |
| 24       | Wall 107 and Clay Deposit 108  | E          | Overcast     |
| 25-26    | General View of Trench 1 Excavated   | S          | Overcast     |
| 27       | Trench 1 Section at W End  | N          | Overcast     |
| 28       | Trench 1 Wall 110 at E End   | S          | Overcast     |
| 29       | Trench 1 Wall 110 at E End   | N          | Overcast     |
| 30-32    | General View of Trench 1 E End   | W          | Overcast     |
| 33-34    | General Views of Trench 1 E End  | W          | Overcast     |
| 35       | Trench 1 Paving 115  | S          | Overcast     |
| 36       | Trench 1 Paving 115 and Wall 107   | SE         | Overcast     |
| 37-38    | Trench 1 N-S Face of Wall 107 Exposed Below Wall 114   | S/Above    | Overcast     |
| 39-40    | Trench 1 N Facing Section of to E of Wall 114 Showing Clay 117 at Base of Fragmented Wall 118 Both Sealed by 102 | S/Above    | Overcast     |
| 41-43    | Trench 2. Internal views of the well   | -          | Flash        |
| 44-45    | Trench 3. General views of the deep and unsafe trench  | NE         | Bright/Shade |
| 46-50    | General Views of Trench 2  | NW         | Sun/Shade    |
| 51       | General Views of Trench 2  | ENE        | Sun/Shade    |
| 52-53    | General Views of Trench 2  | E          | Sun/Shade    |
| 54       | Trench 2 Steps 216, and Wall 217   | W          | Shade        |
| 55       | Trench 2 Wall 217 and Well 222   | W          | Sun/Shade    |
| 56       | Trench 2 Steps 216, Wall 217 and Well 222  | WSW        | Sun/Shade    |
| 57-58    | Trench 2 Steps 216 Wall 217 and Well 222   | WNW        | Sun/Shade    |
| 59-60    | Trench 2 Steps 216, and Wall 217   | N          | Shade        |
| 61       | Trench 2 N Facing Wall 213 E Area  | NE         | Shade        |
| 62-63    | Trench 2 Wall 210 Between E and W Areas Showing Misalignment Between Walls                                       | E          | Shade        |
| 64-65    | Trench 2 W Area, Wood Post 211 Nailed to Wall 210 and General View of Section                                    | NW         | Shade        |
| 66       | Trench 2 Paving 209 in W Area with wooden post 211 top right   | W          | Shade        |
| 67       | Trench 2 E Area and wall 208 E facing elevation  | W          | Shade        |
| 68       | Trench 2 Soil Section at W End   | S          | Sun/Shade    |
| 69-70    | General Views of Trench 2  | W          | Sun/Shade    |
| 71       | Trench 1 and 2 Showing Connection of Walls 114 and 208   | S          | Sun/Shade    |
| 72       | Trench 2 S Facing Section in E Area Showing Depth of Artefact Rich Floor Deposit                                 | S          | Dull         |
| 73       | Trench 2 N Facing Section Showing Wall with Demo Rubble Above  | N          | Dull         |

## APPENDIX 4: Discovery & Excavation in Scotland Entry

|   |   |
|---|---|
| <b>LOCAL AUTHORITY:</b>   | East Lothian  |
| <b>PROJECT TITLE/SITE NAME:</b>   | 1 Kilwinning Street, Musselburgh  |
| <b>PROJECT CODE:</b>  | KIST  |
| <b>PARISH:</b>  | Inveresk  |
| <b>NAME OF CONTRIBUTOR:</b>   | Leigh A. Garst  |
| <b>NAME OF ORGANISATION:</b>  | CFA Archaeology Ltd   |
| <b>TYPE(S) OF PROJECT:</b>  | Archive Assessment and Evaluation   |
| <b>NMRS NO(S):</b>  | None  |
| <b>SITE/MONUMENT TYPE(S):</b>   | Buildings, well, walls  |
| <b>SIGNIFICANT FINDS:</b>   | None  |
| <b>NGR (2 letters, 10 figures)</b>  | NT 3459 7265  |
| <b>START DATE (this season)</b>   | November 2011   |
| <b>END DATE (this season)</b>   | November 2011   |
| <b>PREVIOUS WORK (incl. DES ref.)</b>   | N/A   |
| <b>MAIN (NARRATIVE) DESCRIPTION:</b><br>(May include information from other fields) | An archaeological evaluation covering 59m <sup>2</sup> was carried out by CFA Archaeology Ltd at 1 Kilwinning Street Musselburgh, East Lothian. The evaluation demonstrated the presence of truncated remains of boundary walls and buildings. Some of these are depicted on the 1853 and 1893 Ordnance Survey Musselburgh Town Plans. The remains identified in the evaluation trenches included at least two building phases with external and internal walls, cobble stone flooring, stone steps and a well. |
| <b>PROPOSED FUTURE WORK:</b>  | Not known   |
| <b>CAPTION(S) FOR ILLUSTRS:</b>   | -   |
| <b>SPONSOR OR FUNDING BODY:</b>   | Hackland + Dore Architects Limited  |
| <b>ADDRESS OF MAIN CONTRIBUTOR:</b>   | The Old Engine House, Eskmills Park, Musselburgh, EH21 7PQ  |
| <b>EMAIL ADDRESS:</b>   | cfa@cfa-archaeology.co.uk   |
| <b>ARCHIVE LOCATION (intended/deposited)</b>  | National Monuments Record of Scotland (archive)<br>East Lothian Council Sites and Monuments Record (report)   |



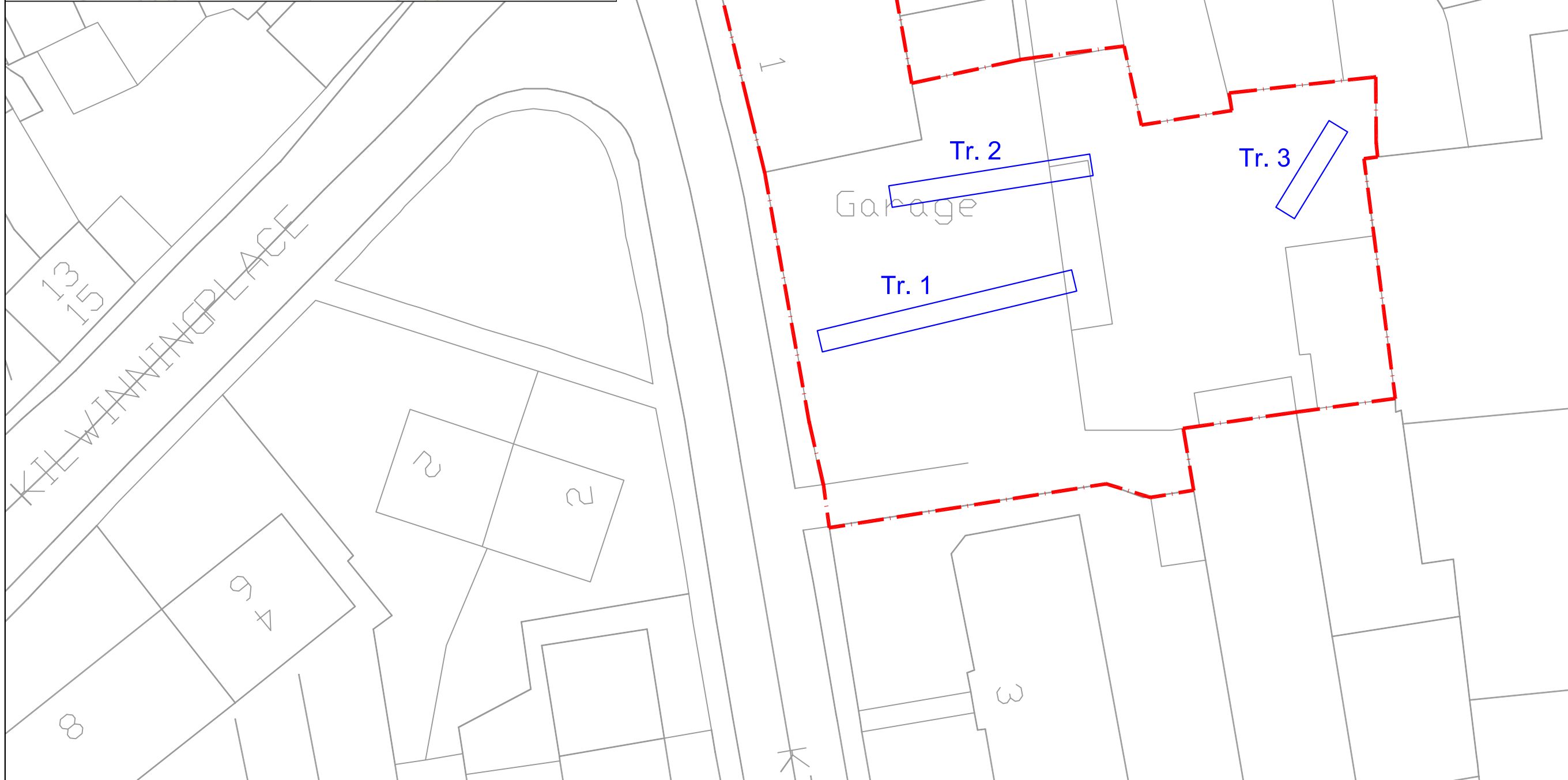
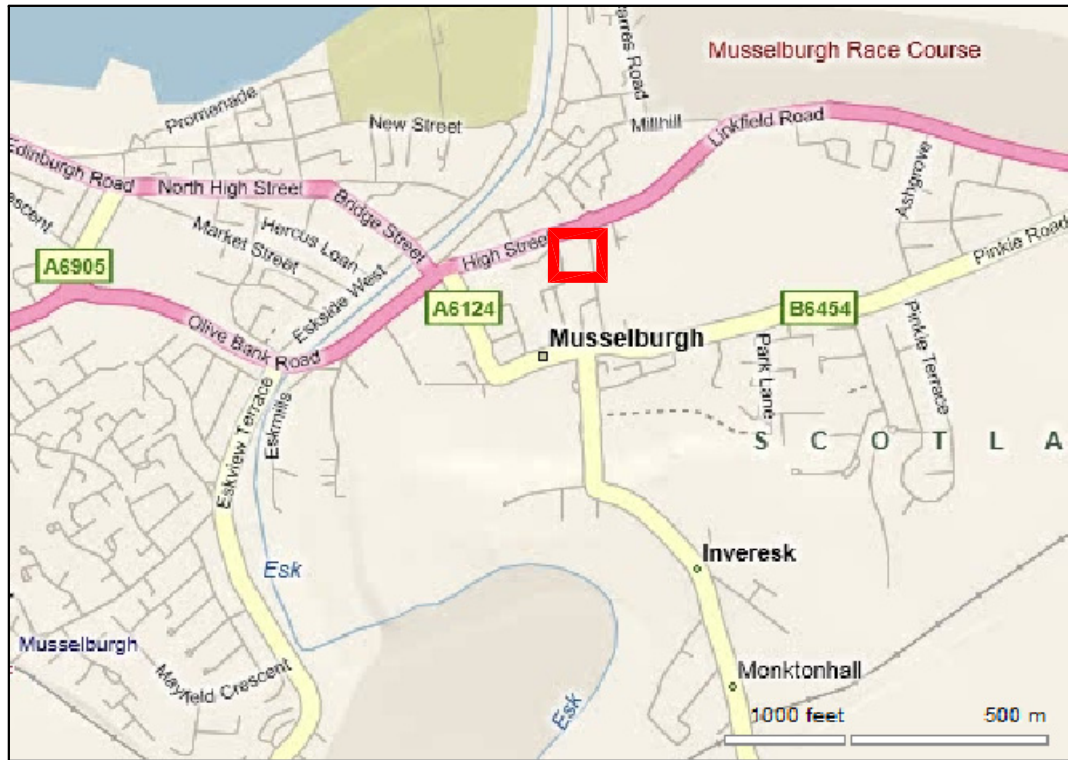

Key:  
 - - - - - Development boundary  
 [ ] Evaluation trench

**CFA** ARCHAEOLOGY LTD  
 The Old Engine House  
 Eskmills Park  
 Musselburgh  
 East Lothian, EH21 7PQ  
 t: 0131 273 4380  
 f: 0131 273 4381  
 e: info@cfa-archaeology.co.uk  
 w: www.cfa-archaeology.co.uk

Fig. No: 1      Revision: A

Title:  
**Site and trench location**

Project:  
**1 Kilwinning Street,  
 Musselburgh, East Lothian**

Client:  
**Hackland + Dore Architects Limited**

Scale at A3:  
**1:300 (main inset)**

Drawn by: KH      Checked: LW      Report No: 1978



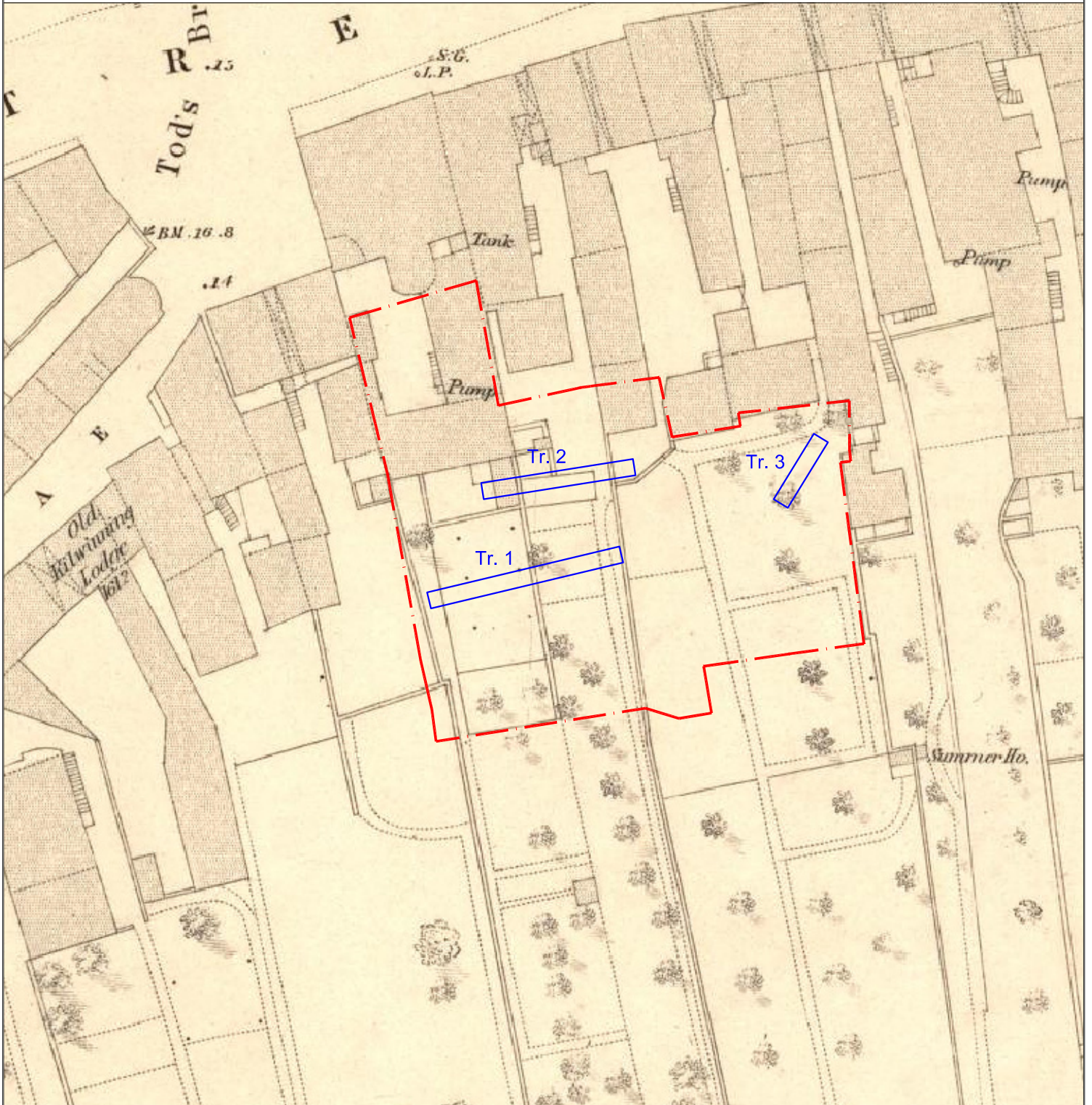

Key:  
 Development boundary



Fig No: 2a      Revision: A      Client: Hackland + Dore Architects Limited

Title: Musselburgh 1853, Ordnance Survey extract

Project: 1 Kilwinning Street, Musselburgh, East Lothian



**CFA**  
 ARCHAEOLOGY LTD  
 The Old Engine House  
 Eskmills Park  
 Musselburgh  
 East Lothian, EH21 7PQ  
 t: 0131 273 4380  
 f: 0131 273 4381  
 e: info@cfa-archaeology.co.uk  
 w: www.cfa-archaeology.co.uk

Scale at A4: 1:500

Drawn by: KH      Checked: LW      Report No: 1978



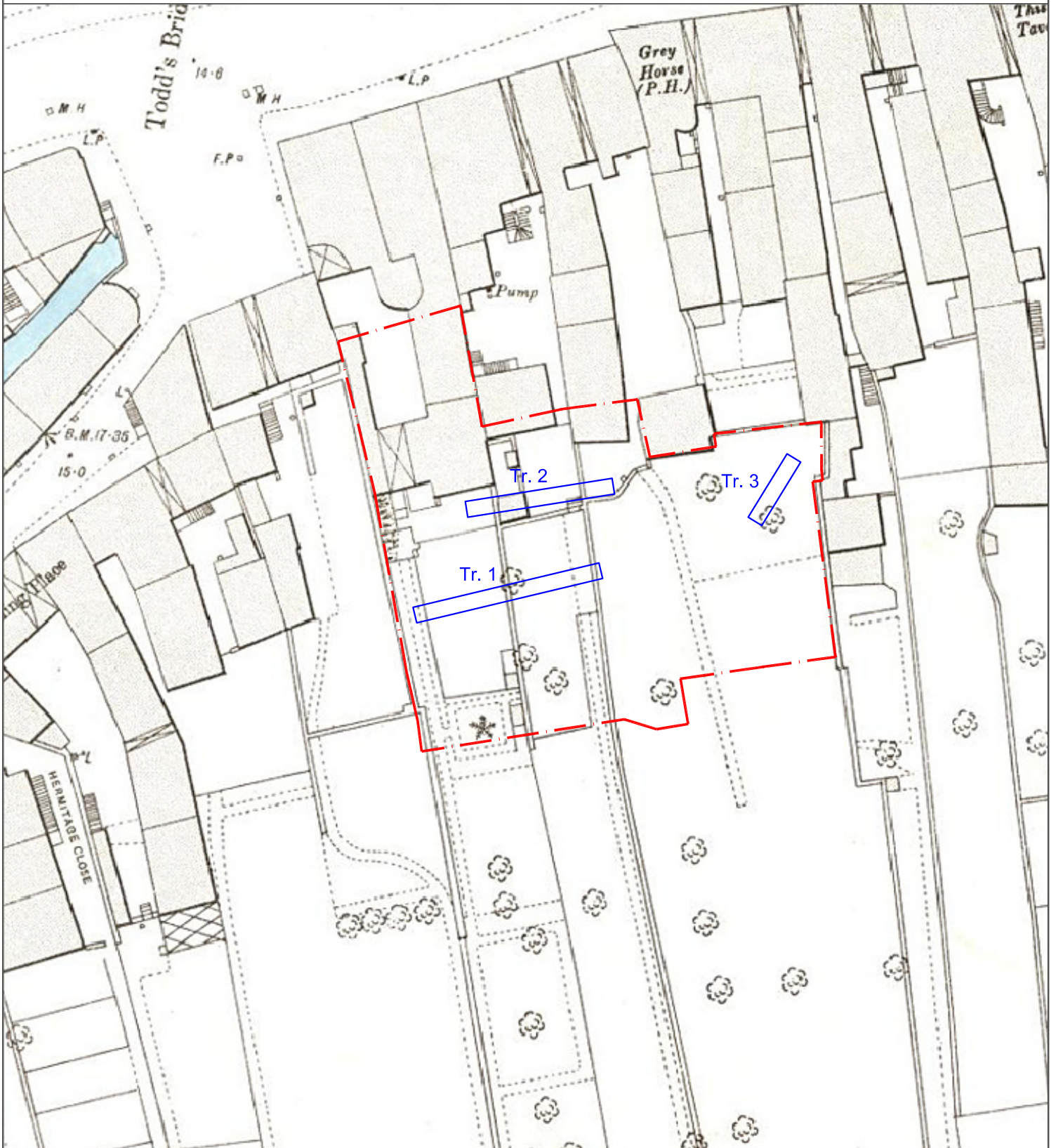

Key:  
 Development boundary



Fig No: 2b      Revision: A      Client: Hackland + Dore Architects Limited

Title: Musselburgh 1893, Ordnance Survey extract

Project: 1 Kilwinning Street, Musselburgh, East Lothian



**CFA** ARCHAEOLOGY LTD  
 The Old Engine House  
 Eskmills Park  
 Musselburgh  
 East Lothian, EH21 7PQ  
 t: 0131 273 4380  
 f: 0131 273 4381  
 e: info@cfa-archaeology.co.uk  
 w: www.cfa-archaeology.co.uk

Scale at A4: 1:500

Drawn by: KH      Checked: LW      Report No: 1978



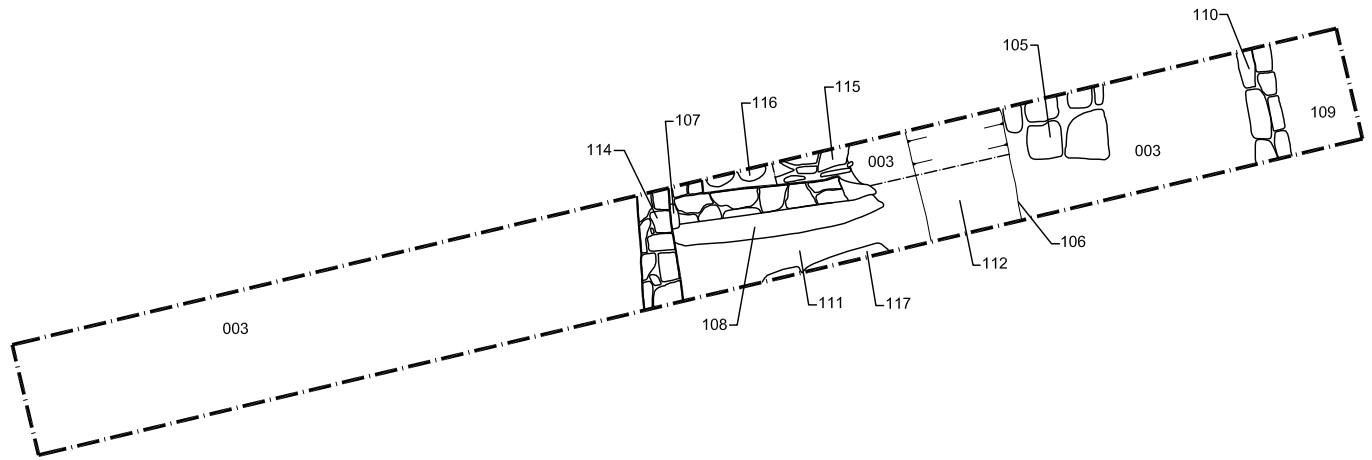



Fig 3 - Trench 1 plan



Fig 4 - The eastern end of Trench 1 from the WNW

|   |         |  |           |   |         |   |  |    |
|---|---------|--|-----------|---|---------|---|--|----|
| Key:  | Fig No: | 3-4  | Revision: | 0 | Client: | Hackland + Dore Architects Limited  |  |    |
|   | Title:  | Trench 1   |           |   |         |   |  |    |
| Scale at A4:  | 1:100   | Project:<br>1 Kilwinning Street, Musselburgh, East Lothian |           |   |         |   |  |    |
|  |         |  |           |   |         |  | CFA ARCHAEOLOGY LTD<br>The Old Engine House<br>Eskmills Park<br>Musselburgh<br>East Lothian, EH21 7PQ<br>t: 0131 273 4380<br>f: 0131 273 4381<br>e: info@cfa-archaeology.co.uk<br>w: www.cfa-archaeology.co.uk |    |
|   |         |  |           |   |         |   | Drawn by:  | KH |



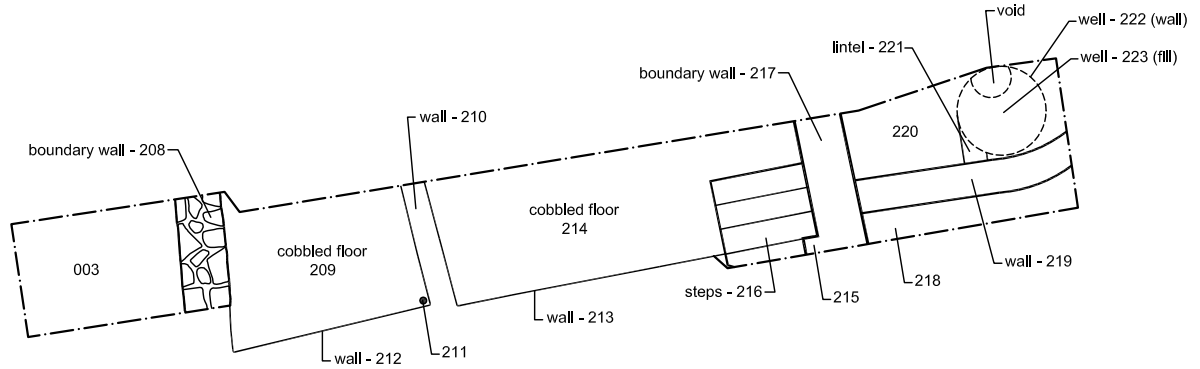



Fig 5 - Trench 2 plan



Fig 6 - The eastern end of Trench 2 from the WNW

|   |         |   |           |  |         |                                    |
|---|---------|---|-----------|--|---------|------------------------------------|
| Key:  | Fig No: | 5-6   | Revision: | 0  | Client: | Hackland + Dore Architects Limited |
|   | Title:  | Trench 2  |           |  |         |                                    |
| Scale at A4:  | 1:100   | Project:<br>1 Kilwinning Street, Musselburgh, East Lothian                            |           |  |         |                                    |
|  |         |  |           | CFA ARCHAEOLOGY LTD<br>The Old Engine House<br>Eskmills Park<br>Musselburgh<br>East Lothian, EH21 7PQ<br>t: 0131 273 4380<br>f: 0131 273 4381<br>e: info@cfa-archaeology.co.uk<br>w: www.cfa-archaeology.co.uk |         |                                    |
|   |         |   |           | Drawn by:  | KH      | Checked:                           |