

Turf Tavern Oxford



Archaeological Evaluation Report

oxfordarchaeology



southsouthsouth

August 2014

Client: ADS Design

Issue No: 1

OA Job No: 5976

NGR: SP 517 065



Client Name: ADS Design
 Client Ref No: N/A
 Document Title: The Turf Tavern, Oxford
 Document Type: Evaluation Report
 Issue/Version Number: Version 1
 Grid Reference: SP 517 065
 Planning Reference: Pre-planning
 Site Code: OXTAV14
 Invoice Code: OXTAVEV
 Receiving Museum: Oxfordshire County Museums Service
 Museum Accession No: OXCMS: 2014.174

Issue	Prepared by	Checked by	Approved by	Signature
1	Robin Bashford Site Supervisor	Ben Ford Senior Project Manager	Ben Ford Senior Project Manager	

Document File Location Projects on Server1:\o\Oxford_Turf Tavern\Report
 Graphics File Location \\Server8\invoice codes I thru q\O_codes\OXTAVEV\Turf Tavern\MD
 Illustrated by Markus Dylewski

Disclaimer:

This document has been prepared for the titled project or named part thereof and should not be relied upon or used for any other project without an independent check being carried out as to its suitability and prior written authority of Oxford Archaeology being obtained. Oxford Archaeology accepts no responsibility or liability for the consequences of this document being used for a purpose other than the purposes for which it was commissioned. Any person/party using or relying on the document for such other purposes agrees, and will by such use or reliance be taken to confirm their agreement to indemnify Oxford Archaeology for all loss or damage resulting therefrom. Oxford Archaeology accepts no responsibility or liability for this document to any party other than the person/party by whom it was commissioned.

© Oxford Archaeology Ltd 2014

Janus House

Osney Mead

Oxford OX2 0ES

t: +44 (0) 1865 263800

e: info@oxfordarch.co.uk

f: +44 (0) 1865 793496

w: oxfordarchaeology.com

Oxford Archaeology Limited is a Registered Charity No: 285627



The Turf Tavern, Oxford

Archaeological Evaluation Report

Written by Robin Bashford

with contributions from John Cotter

and illustrated by Markus Dylewski

Table of Contents

Summary.....	4
1 Introduction.....	5
1.1 Location and scope of work.....	5
1.2 Geology and topography.....	5
1.3 Archaeological and historical background.....	5
2 Evaluation Aims and Methodology.....	8
2.1 Aims.....	8
2.2 Methodology.....	8
3 Results.....	10
3.1 Trench 1.....	10
3.2 Trench 2.....	10
3.3 Trench 3.....	11
4 Discussion.....	12
4.1 Reliability of field investigation.....	12
4.2 Interpretation.....	12
4.3 Evaluation objectives and results.....	12
Appendix A. Trench Descriptions and Context Inventory.....	14
Appendix B. Finds Reports.....	16
B.1 Pottery.....	16
B.2 Clay tobacco pipes.....	18
B.3 Ceramic building material (CBM).....	19
B.4 Glass.....	19
B.5 Small finds.....	20
B.6 Bone.....	20
B.7 Marine shell.....	20



Appendix C. Bibliography and References.....	21
Appendix D. Summary of Site Details.....	22



List of Figures

- Fig. 1 Site location
- Fig. 2 Trench locations
- Fig. 3 Trench 1, Post-ex plan (plan 100) and plan of roots (plan 101)
- Fig. 4 Trench 1, section 100
- Fig. 5 Trench 2, post-ex plan (plan 200)
- Fig. 6 Trench 2, section 200
- Fig. 7 Trench 3, post-ex plan (plan 301)
- Fig. 8 Trench 3, section 300
- Fig. 9 City defences
- Fig. 10 OS 1st Edition 1976



Summary

In July 2014, Oxford Archaeology (OA) was commissioned by ADS Design to undertake an archaeological evaluation at The Turf Tavern, Oxford (SP 517 065). The evaluation comprised three small trenches, two of which were excavated against the northern wall of the terrace garden to the rear (east) of the property, and one against the eastern wall of the same area. The northern wall is on the projected line of an abortive late 13th century attempt to apply the principles of concentric castle architecture to the north-eastern corner of the defences of Oxford - with an outer curtain wall being constructed along the inner edge of the partially backfilled City ditch which then appears to have been re-cut further to the north and east. The evaluation revealed evidence for a substantial earlier wall on the same line as the existing wall of the terrace garden. This may either represent the late-13th century outer curtain wall itself, or a later wall built off it. There was also evidence that a section of this wall had been re-built during a re-configuration of the garden in the 19th century.

The earliest deposit encountered was within a series of augered boreholes in the base of the trenches adjacent to the north wall, and this was fairly consistent in composition in both. Given that the boreholes penetrated below the anticipated elevation of the natural gravel, it seems likely that this deposit was filling a negative feature and if - as the similarity in composition would suggest - the deposits within the boreholes are of the same origin, this may indicate that the feature was linear. It is possible that this feature represents the construction cut for the outer curtain wall although - as indicated above - other excavations along the line of the wall would suggest that it was constructed within the southern edge of the earlier ditch. It is therefore possible that the deposits encountered within the boreholes represent backfill along the edge of, and within, the City ditch, which has then been re-cut to the north following the construction of the outer curtain wall in the late-13th century. However, the relationship between this possible feature and the structural remains within the trenches against the northern wall of the terrace garden was uncertain, and further characterisation of the possible feature or close dating of the structures was not possible within the confines of the trenches.

Some evidence was recovered for an earlier courtyard surface overlying this deposit. The surface comprised limestone 'cobbles' and a linear configuration of kerb stones marking its northern extent.

Overlying this surface, the majority of the deposits excavated within the trenches strongly suggested that the creation of the existing terrace was the result of a phase of landscaping in the 19th century. Some evidence was recovered for a possible brick surface overlying the raised terrace and pre-dating the existing flagstone surface.



1 INTRODUCTION

1.1 Location and scope of work

- 1.1.1 In July 2014, Oxford Archaeology (OA) was commissioned by ADS Design to undertake an archaeological evaluation at The Turf Tavern, Oxford (SP 517 065), (Fig. 1).
- 1.1.2 The evaluation comprised three trenches (Trenches 1-3). Trenches 1 and 2 were excavated against the northern wall of the terrace garden to the rear (east) of the property, and Trench 3 against the eastern wall of the same terrace garden (Fig. 2).
- 1.1.3 The evaluation was carried out prior to submission of the Planning Application, and therefore no formal brief was issued by the Local Planning Authority, although David Radford (Oxford City Archaeologist), and Chris Leyland (Oxford City Tree Officer) were consulted, and approved a Written Scheme of Investigation produced by OA that outlined the aims and methodology of the evaluative work at the Site, and consideration of due care of the roots within the Root Protection Area.

1.2 Geology and topography

- 1.2.1 The Turf Tavern is located on the north-east side of the Oxford City Centre, c 450m from Carfax, south of Holywell Street and north of the medieval elements of New College (Fig. 1).
- 1.2.2 The site lies at c 62.5 m OD. Both routes into it slope down slightly and the yard surfaces are rather uneven, with a mixture of covering. All the outer seating areas are on raised, flagged terraces, c. 0.5m above the passageways and with shallow steps up. The area of the proposed dining extension, now covered by a timber and glass canopy, lies between the east boundary of the site and an existing dining area and forms part of the raised terrace. To its north, separated by a low wall, are further outside seating areas.
- 1.2.3 The Turf Tavern lies midway between the River Cherwell and River Thames, c. 800m from both. The area of proposed development lies on the second or Summertown Radley gravel terrace. The underlying geology is Oxford Clay.

1.3 Archaeological and historical background

- 1.3.1 The following background has been taken from the DBA produced for the client (OA, 2014), which defined the archaeological resource within a Study Area which was defined as the area within a 250m radius from the proposed development area or Site. Full references can be found in that document.

Prehistoric to Roman Periods (500,000BP - 410 AD)

- 1.3.2 No archaeological sites or finds dating to the prehistoric period have been located within the area of proposed development. Within the Study Area a Bronze Age implement was found c. 90m north-east of the Turf Tavern and some evidence for prehistoric and Roman activity was found at Jowett Walk c. 170m away.
- 1.3.3 The presence of prehistoric settlement, field systems and burial monuments in the area of the University Parks has been long established. Crop-marks of ring ditches were known as early as the 17th century. As archaeological work has been carried out during the 20th and early 21st centuries, the extent and range of these sites has increased, finding evidence for all periods from the Neolithic onwards. However, as yet no evidence has been found to suggest that this activity extended as far south as the Turf Tavern. Any evidence will have been substantially damaged or removed by later activity.



Excavations around and within the University Science Area and to the north of the University Parks in the 20th and early 21st centuries have uncovered evidence for occupation during this period. The evidence for farming activity during the Romano-British period within the Study Area and further north is extensive, but, as with the prehistoric period, there is no evidence for it extending southwards to the Turf Tavern, but again any evidence will have been damaged or removed.

Early Medieval Period (AD 410 – 1066)

- 1.3.4 No archaeological sites or finds dating from the Early or Middle Saxon periods have been found within the Turf Tavern site.
- 1.3.5 Oxford was laid out in the late Saxon period as a defended burh. Evidence has been found for the town wall and ditch, originally consisting of an earth rampart with external ditch. The original east side of the town is thought to have lain in the vicinity of Magpie Lane, but later expansion is believed to have enclosed the area which was within the later medieval wall. The Turf Tavern site would have lain at least in part within the ditch, outside the burgh. It is possible that a ditch excavated in 1949 on the north side of the inner wall at New College, c220 m east of the Turf Tavern, may have been part of the Saxon defences. If so, more of this ditch may survive within the area of proposed development itself. The turf facing of the Saxon rampart was identified on the south side of the inner City Wall at New College in 1987, c. 50m east of site.
- 1.3.6 Some pottery dating from the Late Saxon period was found in New College Garden in 1949 and at St Helen's Passage in 1974-5 (Area B), c 210m and 50 m from the Turf Tavern respectively. The level of occupation and activity within that part of the town is uncertain, but it is thought that New College Lane, then called Thorald's Lane, may have Saxon origins.

Later Medieval Period (AD1066-1550)

- 1.3.7 The earlier rampart around Oxford was replaced by stone walls, c 2 m thick, with semi-circular bastions in the first half of the 13th century. The ditch on the outside was generally c 18 m wide, sloping fairly steeply from the wall to a flat-bottomed section, c 7.6 m wide and then rising more gradually. In Oxford the rampart was mostly removed, although in Hereford and Southampton the medieval stone wall was built into an earlier bank.
- 1.3.8 It is possible that some bastions were built or rebuilt later in the 13th century, possibly when the outer line of the City Wall was constructed. The late 13th century outer wall of Oxford did not extend around the whole fortified area, but only the north-east portion, from Smithgate, at the west end of Holywell Street, to the Eastgate on High Street, which includes the Turf Tavern site. Excavations, mainly at 21 Longwall Street in 1910 and 1979-80 (Area E), have shown that the outer wall was only c 1 m wide. It was constructed in the middle of the existing ditch, c 10 m from the inner wall. The section of ditch between the two walls was infilled. If the position of the arrow-slots in the inner bastions was intended to fall above the level of the outer wall, this would suggest that the wall was c 5m on the ditch side. Oxford is unique in having a double stone wall and this combination of the inner and outer walls with the City Ditch in the north-east is of particular significance. None of the outer wall survives above ground and the section of the inner wall within New College represents the best preserved stretch. The up-standing part of Oxford's City Wall are a Scheduled Monument.
- 1.3.9 Within the City Wall the land now occupied by New College had been divided into several plots by the 13th century, in mixed ownership, but with substantial areas held by Osney Abbey and the hospital of St John. The area between the inner City Wall and

an intra-mural lane was held by the Trinitarian Friars. William of Wykeham acquired the land in 1379 for the foundation of New College. The land to the north lay within the estates of Merton College, within the parish of Holywell, but the area including the Turf Tavern site would have lain within the City Ditch until this was partly filled in to allow construction of the outer City Wall in the later 13th century.

Post-Medieval Period (AD1550-1850)

- 1.3.10 At the end of the medieval period the defences were neglected and City Ditch was allowed to fill in. Agas Map of 1587 shows New College extending to the inner wall, but no sign of the outer wall or ditch beyond. The outer wall is shown on the Holywell Terrier from 1660. During the Civil War the medieval defences were repaired and sections of the ditch recut as part of the protection of a major strategic base. The importance of Oxford during the Civil War arose in large part from its association with Charles I. While he was in dispute with parliament the king used Oxford as his base, a temporary capital. The Longwall Street excavations of 1979-80 (Area E) found substantial depths of fill dating from the 17th century. It is clear that the ditch was soon filled in again as both the Terrier and Loggan's Map of 1673 show houses along the whole south side of Holywell Street and a building at the west end of the Turf Tavern site. The tavern was originally a malthouse. When Taylor mapped Oxford the building was still there, but nothing had been built to the east where the proposed development would be located. In 1775 the malthouse was converted to a cider house. It would appear that the Turf Tavern dates from the late 18th century, when it was called the Spotted Cow and the date of the name change is unknown.

Modern Period (AD1851- present)

- 1.3.11 The earliest record found of the name 'Turf Tavern' is on the 1st Edition Ordnance survey map of 1876, which shows a layout very similar to the current one. It is likely that the boundary of the site has increased since the inn first opened and there have been alterations to the smaller buildings. The construction of the seating terraces is a recent change.

Previous archaeological work

- 1.3.12 Evidence from other excavations on the line of the outer City Wall (Areas A-E) as shown on Figure 9 have found that the wall does survive, although much reduced in height. In the post-medieval period, the ditch in which it was set was filled in and the area from the inner City Wall northwards to Holywell Street was built over.
- 1.3.13 The excavations at Hertford College in 1980 (Area A) found a ditch reaching a depth of 3.75m below ground level (58.8m OD) in which the outer City Wall had been constructed. The maximum height of the surviving stretch of wall was 1.75m (60.7m OD). Above the ditch and wall were remains of post-medieval buildings. This excavation was adjacent to an earlier phase of work in 1974-5 (Area B), which had also uncovered a length of the outer City Wall, the top of which lay c. 2.5m below ground level (60.0m OD) (Palmer 1976, 154-5).
- 1.3.14 Excavations at New College in 1993 (Area C) did not find the outer City Wall, the bottom of the trench lying at 60.25m OD (Booth 1995, 211). The outer City Wall was seen in a test pit in the Slype at New College in 1996 (Area D). There its top surface was found c. 1.3 m below ground level. (60.55m OD) (OAU 1996, 2, Figure 1).
- 1.3.15 The former Morris' Garage at 21 Longwall Street also lay on the outer City Wall (Area E). In excavations for its construction the foundations of the outer wall were not reached (Palmer 1976, 152). The excavations carried out during the rebuilding of 21



Longwall Street in 1979-80 were confined to a relatively small area, but the wall was identified at c. 58.7m OD (Durham et al 1983, 23-6).

2 EVALUATION AIMS AND METHODOLOGY

2.1 Aims

General

2.1.1 The aims and objectives of the works were:

- to determine the presence or absence of significant archaeological remains;
- to determine or confirm the approximate extent of any surviving remains;
- to determine the date range, and phasing, of any surviving remains by artefactual dating;
- to determine the condition and state of preservation of any remains;
- to determine the degree of complexity of any surviving horizontal or vertical stratigraphy;
- to assess the associations and implications of any remains encountered with reference to the historic landscape;
- to determine the potential of the site to provide palaeoenvironmental and/or economic evidence, and the forms in which such evidence may survive;
- to determine or confirm the likely range, quality and quantity of the artefactual evidence present.

Specific aims and objectives

2.1.2 The specific aims and objectives were:

- to identify the depth and extent of the medieval outer defensive wall;
- To record infill deposits upon the demolished remains of the wall/or within defensive ditch
- To identify any post-medieval structures built within the reclaimed ditch
- to use the results of the trenching to advise on the type and position of micro-piled foundations

2.2 Methodology

2.2.1 A summary of OA's general approach to excavation and recording can be found in Appendix A of the WSI. Standard methodologies for Geomatics and Survey, Environmental evidence, Artefactual evidence and Burials can also be found in the appendices to that document (Appendices B, C, D and E respectively).

2.2.2 Site specific methodologies will be as follows:

2.2.3 There are a number of trees within and adjacent to the site whose Root Protection Areas RPAs extend within the Site. Chris Leland (Tree Officer OCC) was consulted throughout. No roots over 25mm were cut during the evaluation.

2.2.4 Trench 2 was located adjacent to an existing post of the current roof covering to examine the design of the existing foundations.

2.2.5 The Test Pits were excavated to a maximum of 1.3m below ground level, and then hand augered up to 1.4m from the base of the trench to attempt to locate any potential structural remains of the outer curtain wall.



- 2.2.6 Soil was stored adjacent to the trenches.
- 2.2.7 The entire working area was protected by Heras fencing across the full width of the northern part of the terrace garden.
- 2.2.8 Following the excavation of Trenches 1 and 2, a third trench (Trench 3) was excavated against the eastern wall of the terrace garden in order to establish the density of roots in the south-eastern part of the footprint of the proposed extension.

3 RESULTS

3.1 Trench 1 (Figs. 3 and 4)

3.1.1 Trench 1 measured 1m² and was located 1.2m west of the north-east corner of the terrace bar garden. The trench was hand excavated to 1.3m below ground level (60.68m OD) and augered to a maximum depth of 3.1m below ground level (59.13m OD).

3.1.2 The earliest deposit encountered within Trench 1 (107) was within the augered boreholes and appeared to be a fairly homogeneous deposit of mid olive-brown, sandy silt with up to 25% gravel fragments. If this was all one deposit it was at least 1.5m thick, at which depth the auger encountered an obstruction. This was penetrated by the screw head of the auger into softer deposits beneath, but the composition of these deposits could not be established. Deposit 107 appeared to be overlain by a very loose mid-light yellowish-brown sand and gravel with c10% mortar inclusions and occasional limestone fragments (100). Although the latter deposit was observed in plan, the relationship with the underlying deposit (107) was uncertain as this was only encountered within the borehole and Deposit 100 appeared to be considerably thinner in the borehole to the north (BH1) than that to the south (BH2). Within the trench proper, Deposit 100 had clearly been truncated by an east-west aligned linear feature (101) which is tentatively interpreted as the construction cut for the very badly constructed footing of this section of the garden wall (106). This was un-mortared and poorly faced, with numerous loose limestone blocks and a rough offset/batter 0.8m below ground level, which extended 0.2m into the trench.

3.1.3 The fill (102) of the possible construction cut and Deposit 100 were overlain by two layers of mixed, very loose silt (103 and 104) which had 19th century artefactual material throughout and together measured 0.75m in thickness. Deposit 103 was overlain by a further mixed deposit (108). At the interface between these deposits - in the south-east corner of the trench - were four bricks which may have represented the remnant of a brick surface at the top of the 19th century deposits. Consequently, Deposit 108 is interpreted as a levelling deposit associated with the construction of the existing flagstone surface of the garden courtyard.

3.2 Trench 2 (Figs. 5 and 6)

3.2.1 Trench 2 measured 1m x 0.8m with a 0.6m² sondage to the south-east to investigate the foundation of the column supporting the existing glazed canopy. The trench was located c 2m to the west of Trench 1, and was hand excavated to 1.1m below ground level (61.05m OD) and augered to a maximum depth of 2.5m below ground level (59.65m OD).

3.2.2 The earliest deposit encountered within Trench 2 (204) was exclusively within the three boreholes. This was similar in composition to that encountered within the boreholes in Trench 1 (107), and it is possible that it is part of the same deposit.

3.2.3 Deposit 204 was overlain by a layer of limestone "cobbles" (203) in a very compacted clayey gravel rich matrix. The northern extent of this deposit was marked by an east-west aligned linear configuration of kerb stones (205), and it seems likely that 203/205 represent an earlier courtyard surface to the rear of The Turf. The gap between the kerb stones and the wall may represent a border or flower bed, although the deposit to the north of the kerb stones did not differ greatly in composition from the underlying layer encountered within the boreholes.



- 3.2.4 The footing of the northern wall of the terrace garden was roughly coursed, but well faced and pointed with a creamy white lime mortar (206).
- 3.2.5 The probable surface and the top of Deposit 204 were overlain by two layers of mixed, very loose silt (202 and 201) which had 19th century artefactual material throughout and together measured 0.65m in thickness. Deposit 201 was overlain by a further mixed deposit (200), although the interface between these deposits was marked by a layer of bricks along the western edge of the trench which may have represented the remnant of a brick surface, similar to that seen at the same horizon in Trench 1. Consequently, Deposit 200 is interpreted as a levelling deposit contemporary with Deposit 108 in Trench 1, and is likely to be associated with the construction of the existing flagstone surface of the garden courtyard.

3.3 Trench 3 (Figs. 7 and 8)

- 3.3.1 Trench 3 measured 1.8m (N-S) x 0.65m (E-W) and was located against the eastern wall of the terrace garden, at the boundary with New College. The trench was hand excavated to a maximum of 1.3m below ground level (60.94m OD).
- 3.3.2 The trench was excavated through a 0.75m thick layer of predominantly mid olive-brown sandy silt (303) which was overlain by a mid-dark grey clayey silt (304). Although these deposits were not as mixed as the 19th century deposits within Trenches 1 and 2, artefactual material of a similar date was recovered throughout, and it seems likely that they are of the same origin. At the base of these deposits was a possible interface with a more compacted layer (302), although this was only encountered within a small sondage in the north-west corner. Additionally, as with Trenches 1 and 2, the interface between the upper layer of ?18th century deposition (304) and the overlying modern levelling deposits was marked by a possible earlier surface - in this case a possible earlier flagstone in the south west corner of the trench.
- 3.3.3 The flagstone appeared to overlie the very loose backfill of a possible 19th century, east-west aligned drainage channel - although this was only partially revealed at the southern end of the trench, and not fully characterised.

4 DISCUSSION

4.1 Reliability of field investigation

4.1.1 Although the trenches were limited in size, they represent a good percentage of the overall development area and were well spaced to address the aims of the investigation. Ground conditions were dry and deposits easily identified. Results from the augered boreholes were limited in terms of finds, but useful for identification of deposits and the presence or absence of structural features.

4.2 Interpretation

4.2.1 The origin of the deposit(s) encountered within the augered boreholes is uncertain. However, given that the terrace gravel has recently been recorded at 61.56m OD c100m to the east, the fact that the boreholes penetrated significantly below the anticipated elevation of the natural geology would suggest that this deposit was filling a negative feature and if - as the similarity in composition would suggest - the deposits within the boreholes are of the same origin, this may indicate that the feature was linear. It is possible that this feature represents the construction cut for the outer curtain wall although other excavations along the line of the wall would suggest that it was constructed within the earlier ditch and that the ditch was then infilled behind (Durham *et al*, 1983). It is therefore possible that the deposits encountered within the boreholes represent backfill along the edge of the City ditch, which has then been re-cut to the north following the construction of the outer curtain wall in the late-13th century. However, the relationship between this possible feature and the structural remains within the trenches against the northern wall of the terrace garden was uncertain, and further characterisation of the possible feature or close dating of the structures was not possible within the confines of the trenches.

4.2.2 If the surface within Trench 2 does represent an earlier courtyard, then Wall 206 must have been above ground prior to the deposition of the landscaping material. Although some of the small finds recovered from these deposits appear to be of 20th century origin, the vast majority of the artefactual evidence would suggest that this phase of landscaping is likely to have occurred in the late-19th century, and that - given the loose nature of the deposits and the presence of roots in all three trenches - the later finds may have been intrusive.

4.2.3 Additionally, if these landscaping deposits are of the same origin - as seems to be the case - then that would imply that the wall in Trench 1 is a very badly constructed rebuild of this section of the wall, which is possibly contemporary with the landscaping and may even be blocking a doorway giving access to the outbuildings on the other side of the wall. It is perhaps significant that the ground level to the north of the wall is approximately that of the probable courtyard surface in the terrace bar garden.

4.2.4 The OS 1st edition map of 1876 shows the location of the existing terrace garden as an open area to the west of New College bell tower, with some outbuildings against the northern boundary wall (Fig. 10). The existing eastern extension to The Turf does not appear to have been constructed by this date, and it is possible that the current configuration of the building is contemporary with the creation of the raised terrace garden and the construction of the boundary wall with New College.

4.3 Evaluation objectives and results

- to identify the depth and extent of the medieval outer defensive wall;



- 4.3.1 The date of the structure in Trench 2 is uncertain - as is the relationship with the deposits encountered within the augered boreholes. As has been suggested above, it seems likely that the wall revealed within Trench 2 was originally above ground, and that therefore it is possible that it is a remnant of the late 13th century wall, or a later wall built off the footings of the earlier structure. The structure in Trench 1 is almost certainly a later re-build or blocking of a doorway through the wall and is probably of late 19th century date.
- 4.3.2 The maximum depth of the augered boreholes were 3.1m below ground level (59.13m OD) in Trench 1 and 2.5m below ground level (59.65m OD) in Trench 2. The re-built section of wall in Trench 1 corbelled out c0.2m at 0.8m below ground level, although auger hole BH1 would suggest that this is the extent of the offset. In Trench 2 the south face of the wall was vertical with auger holes A1 and A2 showing no indication of an offset to at least 59.65m OD. The archaeological trenching carried out in St Helen's Passage in the 1970s (Palmer, 1976) encountered the footing of the late 13th century outer curtain wall at around 60mOD, and recorded that the southern face was vertical until the wall bottomed out at around 58.75mOD (*ibid*, Fig 3, p154). Whilst it is possible that the build of the wall is not consistent along its entire length, the findings from St Helen's Passage - together with the results of the current evaluation (ie - no offset at 59.13mOD) - would appear to indicate that there is no significant offset in the section of wall in the garden of The Turf.
- To record infill deposits upon the demolished remains of the wall/or within defensive ditch
- 4.3.3 It is possible that the deposit(s) encountered within the augered boreholes represents backfill within the City ditch, although this was only encountered within the boreholes and therefore the dating and characterisation of the deposit was problematic.
- To identify any post-medieval structures built within the reclaimed ditch
- 4.3.4 No post-medieval structures were encountered with the exception of the earlier courtyard surface in Trench 2 and the ?late 19th century re-build in Trench 1.
- to use the results of the trenching to advise on the type and position of micro-piled foundations
- 4.3.5 The Desk Based Assessment indicated that the maximum impact of the foundations of the proposed dining extension would be 1.5m below the level of the modern paving (61m OD). However, this was based on the likelihood of either a raft or strip foundation design. The alternative design of micro-piled foundations would have significantly less impact on archaeological deposits and tree roots, although would penetrate to a greater depth. The results of the evaluation have confirmed that there are no structural remains to the south of the garden wall to at least 3.1m below ground level (59.13m OD) and - together with the results of the trenching in St Helen's Passage - would suggest that it is unlikely that any surviving 13th century fabric below this depth would be offset.



APPENDIX A. TRENCH DESCRIPTIONS AND CONTEXT INVENTORY

Trench 1						
General description					Orientation	-
Possible moat backfill cut by construction trench for very poorly contracted re-build of northern wall of terrace garden, abutted by late 19th century landscaping deposits					Avg. depth (m)	1.3
					Width (m)	1
					Length (m)	1
Contexts						
Context no	Type	Width (m)	Depth (m)	Comment	Findings	Date
100	Layer		0.4	possibly construction debris associated with 19th century re-build of wall		
101	Cut	0.5+	0.6?	construction cut for re-build wall		
102	Fill	0.5+	0.6?	fill of construction cut 101		18th-19thC
103	Deposit		0.5	imported 19thC landscaping deposit		late 19thC
104	Deposit		0.26	imported 19thC landscaping deposit		late 19thC
105	Deposit		0.2	soil overlying footing 106 in threshold of doorway		
106	Structure			east-west aligned wall - probably a very poorly constructed re-build of the wall seen in trench 2		
107	Deposit		1.3+	possible backfill of city ditch		
108	Deposit		0.25	possible levelling deposit for existing flagstone courtyard surface		
Trench 2						
General description					Orientation	-
Possible moat backfill overlain by courtyard surface overlain by 19th century landscaping deposits					Avg. depth (m)	1.1
					Width (m)	1
					Length (m)	1
Contexts						
Context no	Type	Width (m)	Depth (m)	Comment	Findings	Date
200	Deposit		0.2	possible levelling deposit for existing flagstone courtyard surface		
201	Deposit		0.2	imported 19thC landscaping deposit		late 19thC



202	Deposit		0.5	imported 19thC landscaping deposit		
203	Surface		0.1	courtyard surface		
204	Deposit		1.4+	possible backfill of city ditch		
205	Structure			kerb stones marking northern extent of surface 203		
206	Structure		1.1+	east-west aligned wall		

Trench 3

General description	Orientation	N-S
19th century landscaping deposits	Avg. depth (m)	1
	Width (m)	0.65
	Length (m)	1.8

Contexts

Context no	Type	Width (m)	Depth (m)	Comment	Finds	Date
300	Deposit			levelling deposit for construction horizon for modern flagstone courtyard surface		
301	Deposit			compacted gravel horizon - probable construction horizon for existing flagstone courtyard surface		
302	Deposit			possible earlier courtyard horizon		
303	Deposit		c0.6	imported 19thC landscaping deposit		
304	Deposit		0.2+	imported 19thC landscaping deposit		



APPENDIX B. FINDS REPORTS

B.1 Pottery

by John Cotter

Introduction and methodology

- B.1.1 A total of 40 sherds of pottery weighing 876g was recovered from five contexts. This is all of post-medieval date. All the pottery was examined and spot-dated during the present assessment stage. For each context the total pottery sherd count and weight were recorded on an Excel spreadsheet, followed by the context spot-date which is the date-bracket during which the latest pottery types in the context are estimated to have been produced or were in general circulation. Comments on the presence of datable types were also recorded, usually with mention of vessel form (jugs, bowls etc.) and any other attributes worthy of note (eg. decoration etc.). Types present are summarised below and detailed in the spreadsheet. Post-medieval pottery fabric codes noted in the spreadsheet or below are those of the Museum of London (LAARC 2007).

Date and nature of the assemblage

- B.1.2 Although small, the assemblage is in good condition and includes a few complete vessel profiles. Ordinary domestic pottery types are represented. All five contexts produced 19th-century pottery but most also produced a few sherds of 18th-century pottery. A cylindrical preserve jar (REFW) in context (104) may be as late as the early 20th century. Cross-joining sherds between contexts (201) and (104) and probably (103) were noted. Most of the sherds come from mass-produced products of the Staffordshire and Midlands potteries of the late 18th and 19th centuries - mainly the latter. These include plain (REFW) or transfer-printed (TPW) Staffordshire-type white earthenwares (c 1830+). Vessel forms in the latter include tankards and two large sub-rectangular dishes. One of the latter shows external scorching - probably from heating food. A sherd of yellow ware probably comes from a sanitary ware item such as a washbasin or a water closet (c 1860+). The 18th-century pottery includes local redwares (PMR), Staffordshire combed slipware (STSL), Chinese porcelain (CHPO) and sherds from two decorated dishes of c 1700-1750 in tin-glazed ware (TGW). The earliest piece is a sherd of Surrey/Hampshire border ware (BORDG, c 1550-1700) from (303). No further work is recommended.



Context	Spot-date	No.	Weight	Comments
102	18-19C?	1	7	Plain flaring rim from unusual conical dish/bowl in post-med red earthenware (PMR), diam c120mm. Glazed on inside only
103	c1830-1900	9	132	3x transfer-printed ware (TPW) incl profile (2 joining) Willow pattern dish rim & footring base from tankard with ?Chinese landscape & trace of printed maker's mark underside. 1x Pearlware blue feather edge dish (PEAR). 2 Creamware incl rosette border dish rim (CREA). 1x Staffs combed slipware dish base (STSL). 1x 18C tankard handle prob Midlands stoneware (ENGS). 1x footring base 18C Chinese porcelain bowl (CHPO) with traces blue dec
104	c1860-1920	10	280	Profile (3 joining) cylindrical preserve jar in refined white earthenware (REFW) with impressed mark under of 'MALING NEWCASTLE' & letter 'K'. 1x bo (bodysherd) yellow ware (YELL) sanitary ware/water closet? 3x TPW. 1x saucer profile in English porcelain (ENPO) late-looking with blue & red painted border lines near rim. 1x bo PMR. 1x pad base from 18C STSL porringer
201	c1830-1900	11	375	8x TPW incl large joining sherds from 2 large sub-rectangular 'Willow Pattern' dishes: 1 shows evidence of heating/scorching ext; the other JOINS rim in (104). Also bos from 2 TPW tankards - incl rim poss JOINS base in (103)? 1x REFW cup bo with gilding & complete handle. 1x base 19C stoneware cylindrical ink/blacking bottle (ENGS). 1x flat ?dish/bowl base in pale pink-buff sandy fabric - looks like Surrey/Hants border ware with int greenish glaze (BORDG) but might be an 18C Brill or Wealden product (?) has traces of ?whitewash int
303	c1820-1840?	9	82	1x small saucer profile in Pearlware with Chinese-style transfer-printed dec int (PEAR TR, c1790-1840). 1x PEAR dish rim with blue feather edge. 1x bo Creamware with banded coloured slips & engine-turned dec incl Greek key (CREA SLIP). 1x ENGS cylind bottle bo (c1820+). 1x bo PMR. 1x bo 18C Brill marbled slipware (BRSL). 1x bo BORDG. 2x 18C English tin-glazed earthenware (TGW) dish sherds incl footring base - both with blue-grey painted dec - probably c 1700-1750
TOTAL		40	876	

B.2 Clay tobacco pipes

by John Cotter

B.2.1 A total of 27 pieces of clay pipe weighing 191g was recovered from five contexts. These have been catalogued and recorded on an Excel spreadsheet. The catalogue records, per context, the spot-date, the quantity of stem, bowl and mouth fragments, the overall sherd count, weight, and comments on condition and any makers' marks or decoration present. The catalogue comprises 11 pipe bowl fragments (from 11 bowls), 16 pieces of stem but no mouthpieces. Though fragmentary the condition of the material is quite fresh and includes 5 complete bowls and long fresh pieces of stem up to 110mm long.

Most of the bowls are local 18th-century types, all plain. These include two bowls of St Ebbe's Type C of c 1690-1720 (Oswald 1984, fig. 51C) and at least five bowls of Type D of c 1750-1790 (ibid., fig. 51D). There are three damaged bowls of the mid 19th century including two with damaged makers' initials on the spur or heel. Some stems of this date are also present. The quantity of pipe fragments recovered is quite high for a small excavation and may be suggestive of tavern refuse. No further work is recommended.

Context	Spot-date	Stem	Bowl	Mouth	Tot sherds	Tot Wt	Comments	MIN No Bowls
102	c1750-1790	7	4	0	11	90	3x bowls of St Ebbes Type D (1750-90) incl 2 complete - all fresh but smoked. 1x stem with trace of heel bowl - prob Type D? Long fresh 18C stems up to 110mm long	4
103	19C	2	0	0	2	11	Long fresh stems up to 75mm incl slender 19C with Stem bore (SB) c1.8mm. 1 prob 18C	0
104	Mid 19C	2	1	0	3	12	Damaged prob mid 19C fluted bowl bse with squared heel with relief 'I' or 'T' on surname side (forename chipped off). Slender 19C stems to 80mm	1
201	Mid 19C	3	6	0	9	68	2x mid 19C spurred bowl bases: 1 with 'R' on forename side (surname side damaged); 1 with small 5-pointed stars either side of spur. 2x bowls St Ebbes Type D (1750-90) incl 1 fresh complete & burnished. 2x complete bowls St Ebbes Type C (c1690-1720) both with button-trimmed rims. Stems 18C & 19C	6
303	18-E19C	2	0	0	2	10	Fairly chunky stems with SBs c2.2mm, poss from Type D bowl?	0
TOTAL		16	11	0	27	191		11

B.3 Ceramic building material (CBM)

by John Cotter

B.3.1 Three pieces of CBM weighing 286g were recovered from three contexts. These have not been separately catalogued but are described below. No further work is recommended.

Context (103) Spot-date: 15th-17th century

B.3.2 Description: 1 piece (130g): Fairly fresh fragment from the top right-hand corner of a sandy reddish-brown peg tile with a circular nailhole. Apparently in the local late medieval/early post-medieval roof tile fabric.

Context (104) Spot-date: 17th-19th century

B.3.3 Description: 1 piece (29g): Fairly fresh edge fragment from a peg tile in fairly smooth light orange-brown post-medieval fabric.

Context (201) Spot-date: c 1900+

B.3.4 Description: 1 piece (127g): Fragment from the top of an electrical insulator in vitreous white porcelain. Spinning-top shaped with a flattened top and with a screw-thread in the middle. Possibly from a telephone cable mast?

B.4 Glass

Ian R Scott

B.4.1 There are 3 pieces of glass from three context:

- Context 104: (1) Soda water bottle rim or finish. Tooled finish made with applied glass. Pale blue green metal. Late 19th century. Ht: 38mm; D: 35mm



- Context 201: (2) Soda water bottle body sherd with moulded decoration. This comprises a large monogram (probably 'C A R' intertwined) within a circular border. Around the border is embossed: 'TRADE M[ark] . . . REGISTE[red]'. There is further embossing below the circle, possibly '. . . OXF . . .' but incomplete. Pale blue green metal. Later 19th century. 108mm x 58mm.
- Context 303: (3) Cylindrical bottle, base. Probably moulded bottle, with small pushup and pontil mark. Colourless metal. Late 19th- or early 20th century. D: 70mm.

B.4.2 All the glass is of later 19th-century date and possibly of early 20th-century date.

B.5 Small finds

Ian R Scott

B.5.1 There are 7 small finds from four contexts:

- Context 103: (1) Small finger ring, with very slim hoop and green cut glass in a sheet metal setting. Child's toy or trinket ring. Probably recent. Cu alloy and glass. 9mm x 15mm.
- Context 104: (2) Small iron ball, a little encrusted. Possibly a small cannon ball. Fe.D:c40mm
(3) Tapered point of moulded dark grey or black plastic. Oval cross section, incomplete. Modern. Plastic. L: 54mm
- Context 201: (4) Nail, hand-made nail with flat sub rectangular head and tapering stem, complete. L: c 60mm
(5) Nail encrusted possibly complete. L: c 60mm
(6) Large eyelet, cu alloy, probably from tarpaulin sheet. D: 33mm.
- Context 303: (7) Peg, incomplete, moulded in white plastic with groove around its top. Precise purpose uncertain. Modern. L: 35mm; D: 10mm.

B.5.2 All the finds could be of 20th-century date, with possible exception of the small iron ball (context 104), which cannot be closely dated.

B.6 Bone

Identified by Lena Strid

B.6.1 All bones are fragmentary unless stated otherwise.

Context 201

B.6.2 1 large sheep metatarsal; 1 large mammal vertebra, 38g

B.7 Marine shell

Identified by Rebecca Nicholson

Context 303

B.7.1 1 fragment large crab claw, 7g

**APPENDIX C. BIBLIOGRAPHY AND REFERENCES**

- Dodd, A (Ed) 2003 *Oxford Before the University. The late Saxon and Norman archaeology of the Thames Crossing, the defences and the town.* Thames Valley Landscapes Monograph No.17
- Durham et al 1983 *Oxford's Northern Defences.* Oxoniensia **XLVIII**
- English Heritage 2006 Management of Research Projects in the Historic Environment: The MoRPHE Project Managers' Guide.
- Hey, G. and Lacey, M 2001 Evaluation of Archaeological Decision-making Processes and Sampling Strategies.
- Oxford Archaeology 1992 Fieldwork Manual, (Ed. D Wilkinson, first edition, August 1992)
- Oxford Archaeology 2000 OA Environmental Sampling Guidelines and Instruction, Manual.
- Oxford Archaeology 2014 *The Turf Tavern, Oxford.* Archaeological Desk Based Assessment
- Oxford Archaeology 2014 *The Turf Tavern, Oxford.* Written Scheme of Investigation for an Archaeological Watching Brief.
- Palmer, N 1976 *Excavations on the Outer City Wall of Oxford.* Oxoniensia **XLI**



APPENDIX D. SUMMARY OF SITE DETAILS

Site name:	The Turf Tavern, Oxford
Site code:	OXTAV14
Grid reference:	SP 517 065
Type:	Evaluation
Date and duration:	July 2014, 1 week
Area of site:	c3m ²

Summary of results: In July 2014, Oxford Archaeology (OA) was commissioned by ADS Design to undertake an archaeological evaluation at The Turf Tavern, Oxford (SP 517 065). The evaluation comprised three small trenches, two of which were excavated against the northern wall of the terrace garden to the rear (east) of the property, and one against the eastern wall of the same area. The northern wall is on the projected line of an abortive late 13th century attempt to apply the principles of concentric castle architecture to the north-eastern corner of the defences of Oxford - with an outer curtain wall being constructed along the inner edge of the partially backfilled City ditch which then appears to have been re-cut further to the north and east. The evaluation revealed evidence for a substantial earlier wall on the same line as the existing wall of the terrace garden. This may either represent the late-13th century outer curtain wall itself, or a later wall built off it. There was also evidence that a section of this wall had been re-built during a re-configuration of the garden in the 19th century.

The earliest deposit encountered was within a series of augered boreholes in the base of the trenches adjacent to the north wall, and this was fairly consistent in composition in both. Given that the boreholes penetrated below the anticipated elevation of the natural gravel, it seems likely that this deposit was filling a negative feature and if - as the similarity in composition would suggest - the deposits within the boreholes are of the same origin, this may indicate that the feature was linear. It is possible that this feature represents the construction cut for the outer curtain wall although - as indicated above - other excavations along the line of the wall would suggest that it was constructed within the southern edge of the earlier ditch. It is therefore possible that the deposits encountered within the boreholes represent backfill along the edge of, and within, the City ditch, which has then been re-cut to the north following the construction of the outer curtain wall in the late-13th century. However, the relationship between this possible feature and the structural remains within the trenches against the northern wall of the terrace garden was uncertain, and further characterisation of the possible feature or close dating of the structures was not possible within the confines of the trenches.

Some evidence was recovered for an earlier courtyard surface overlying this deposit. The surface comprised limestone 'cobbles' and a linear configuration of kerb stones marking its northern extent.

Overlying this surface, the majority of the deposits excavated within the trenches strongly suggested that the creation of the existing terrace was the result of a phase of landscaping in the 19th century. Some evidence was recovered for a possible brick surface overlying the raised terrace and pre-dating the existing flagstone surface.

Location of archive: The archive is currently held at OA, Janus House, Osney Mead, Oxford, OX2 0ES, and will be deposited with the Oxfordshire County Museum Service in due course, under the following accession number: OXCMS: 2014.174

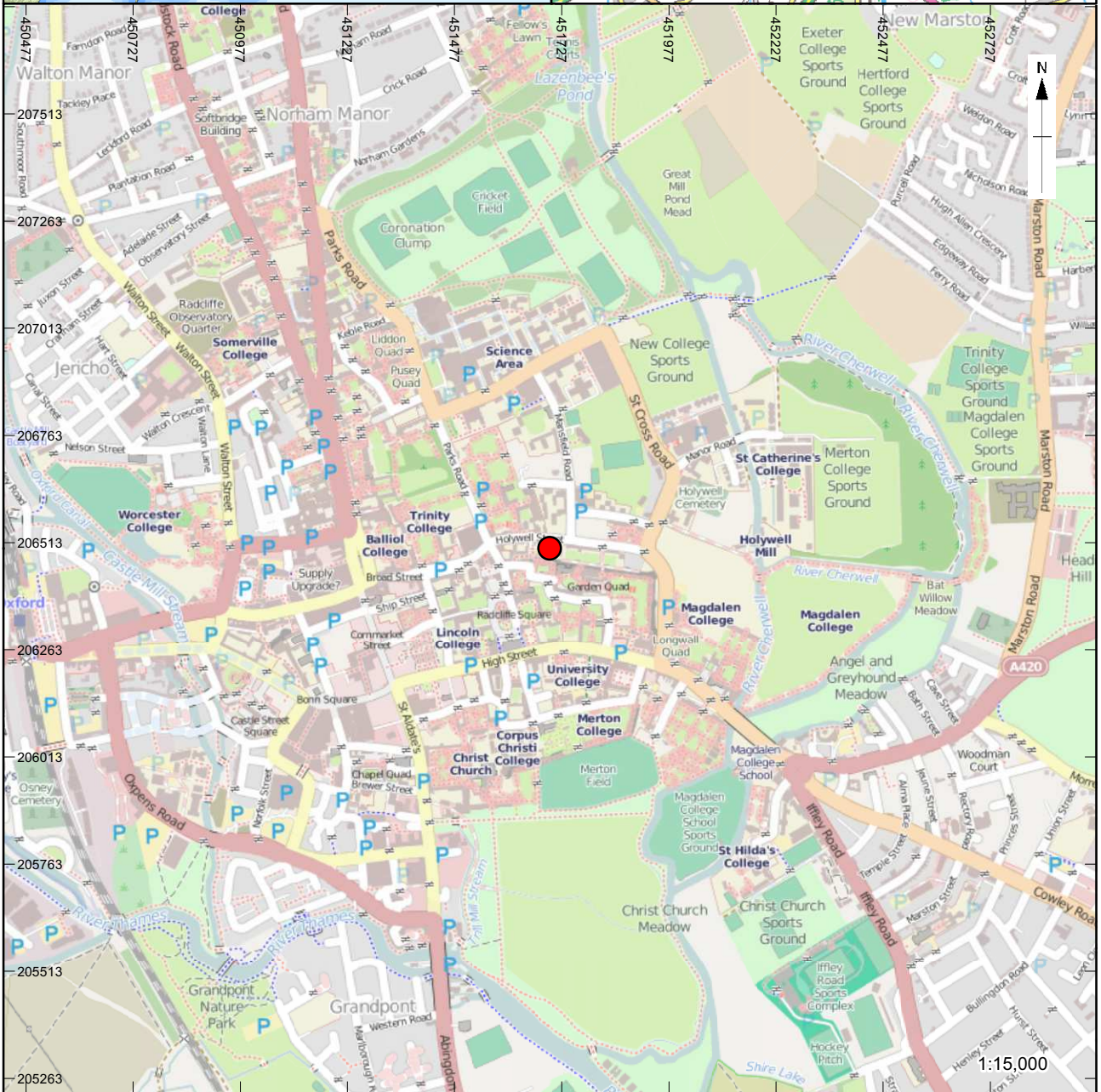
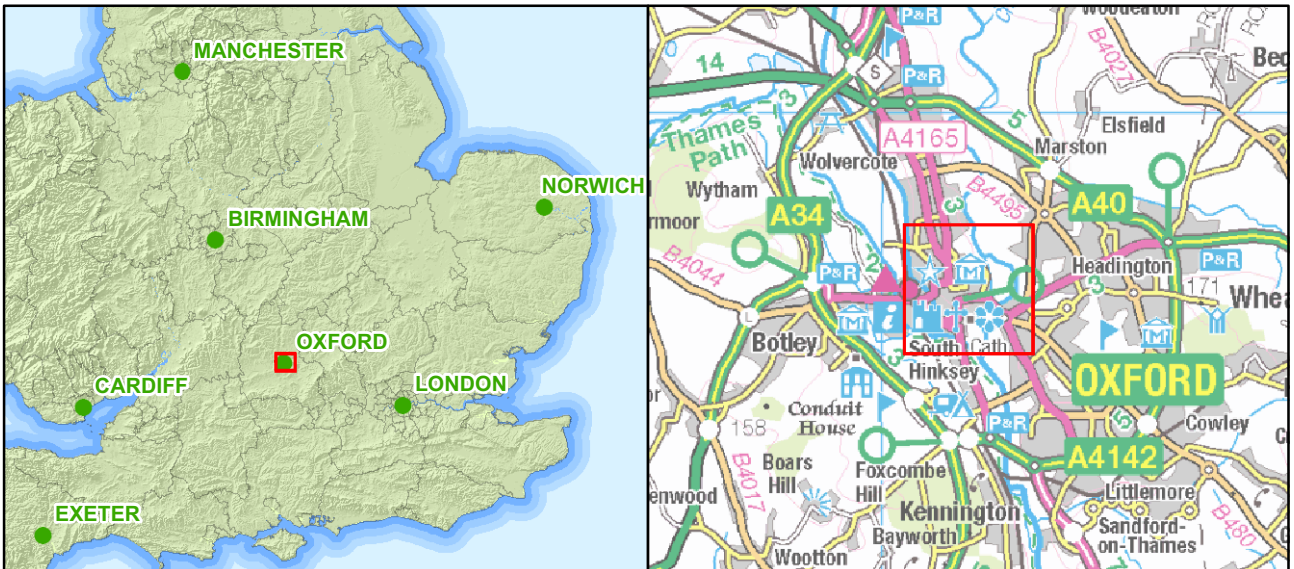

\\server8\invoice codes i thru q\OXTUTVCO\OXTUTVCO_Fig_01.mxd\markus.dylewski\14/05/2014

Contains Ordnance Survey data © Crown copyright and database right 2014
 (c) OpenStreetMap and contributors, Creative Commons-Share Alike License (CC-BY-SA)

Figure 1: Site location

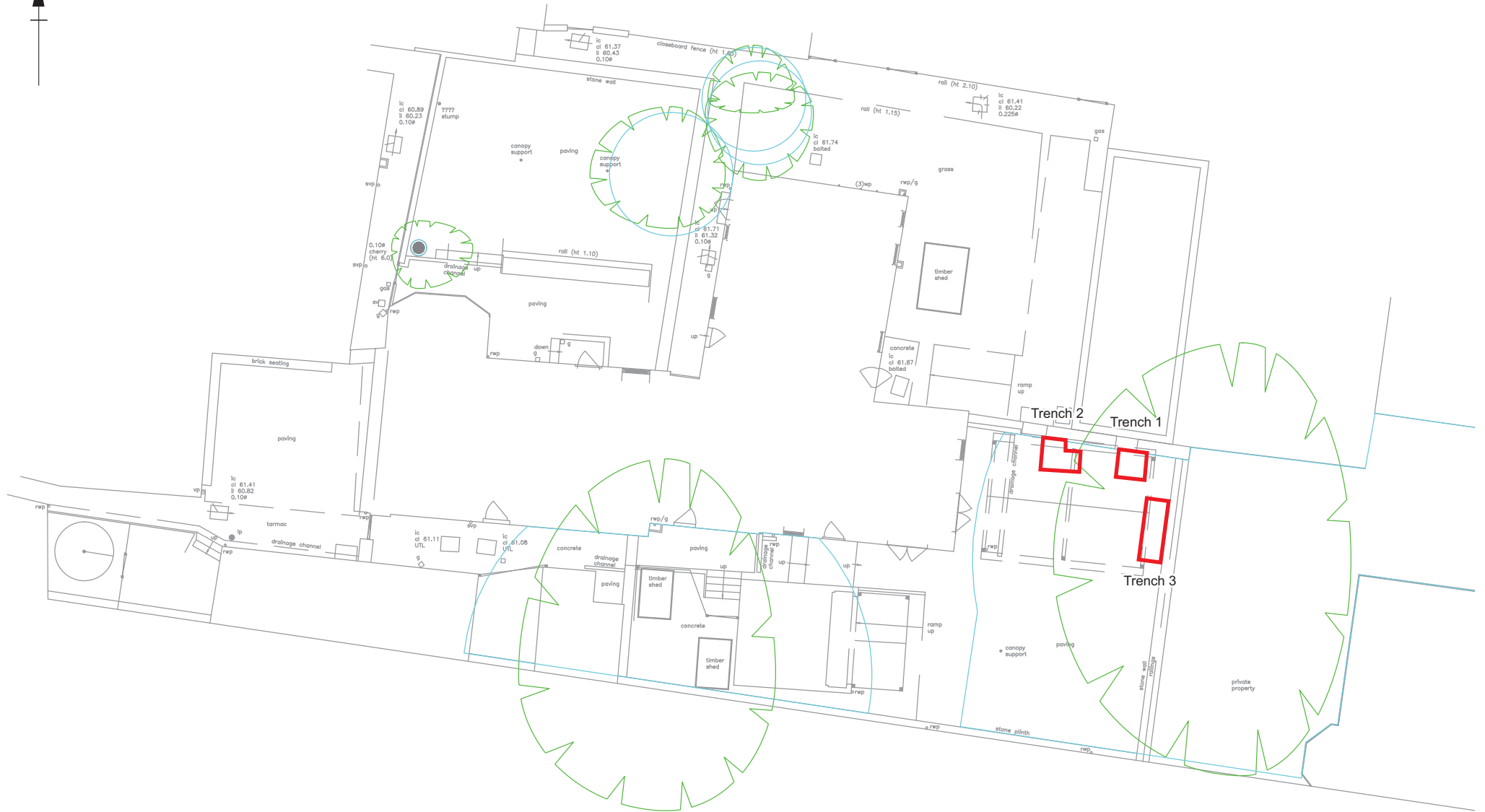
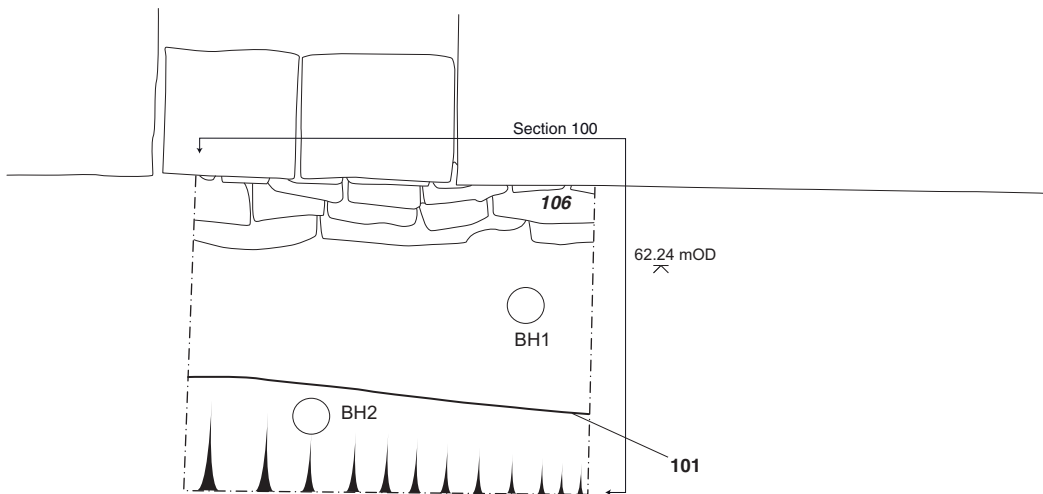

Figure 2: Trench locations





Plan 100

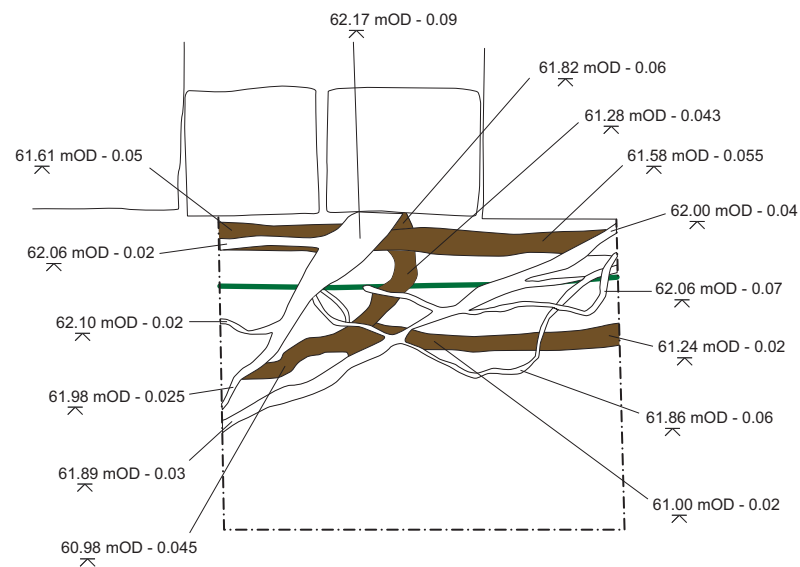

Plan 101



Height of flagstones: 62.24 mOD

Height	Diameter at root
62.17 mOD - 0.07	
	Orangey brown roots
	CU alloy cable

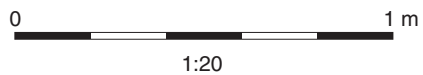

Figure 3: Trench 1, Post-ex plan (plan 100) and plan of roots (plan 101)

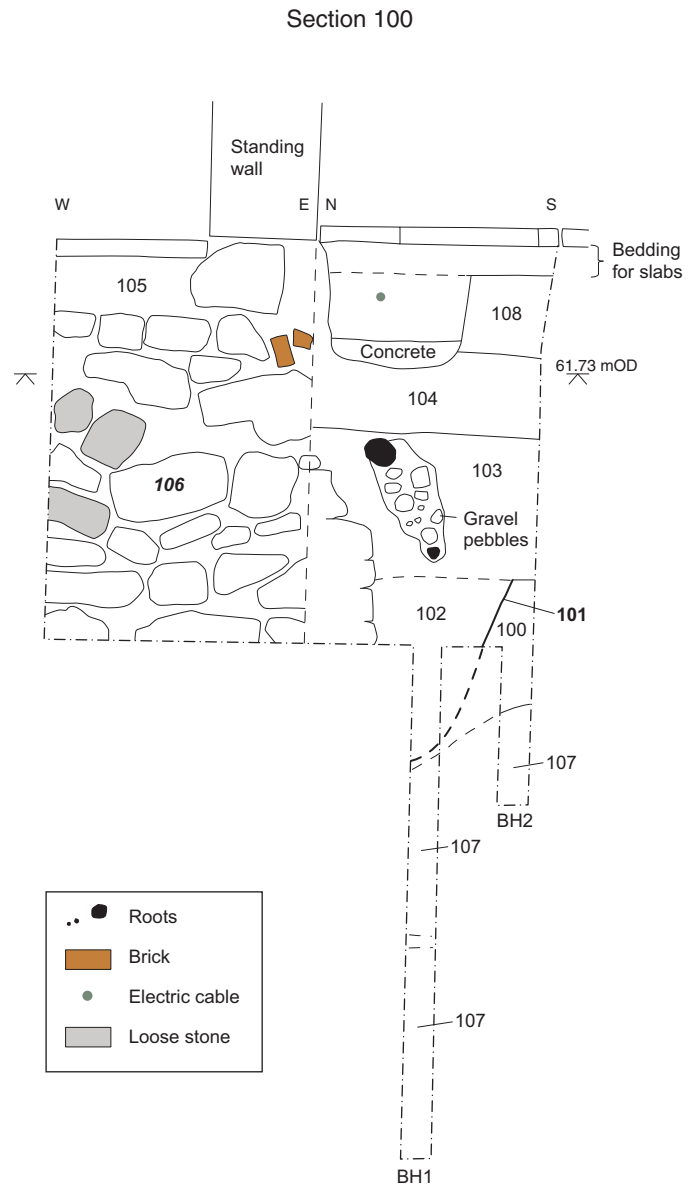

Figure 4: Trench 1, section 100



Plan 200

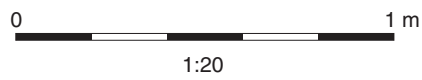
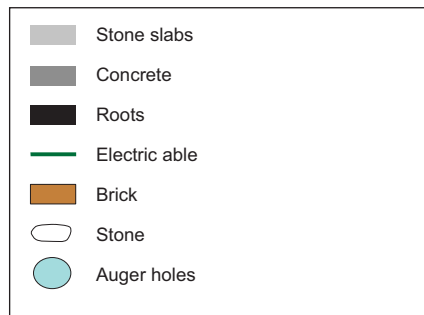
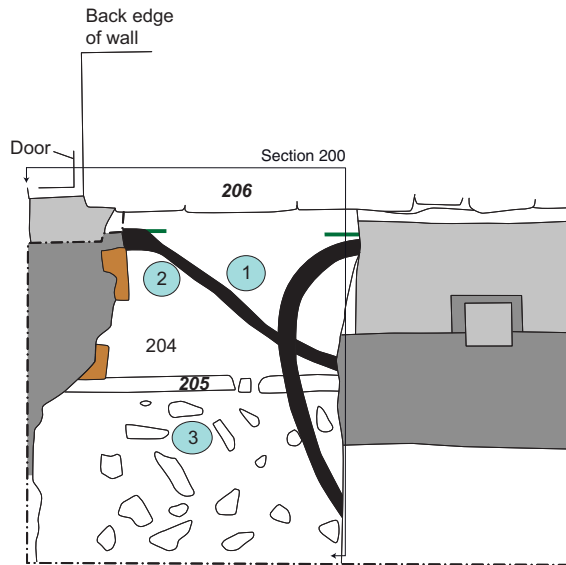

Figure 5: Trench 2, post-ex plan (plan 200)

Section 200

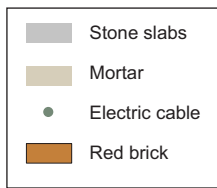
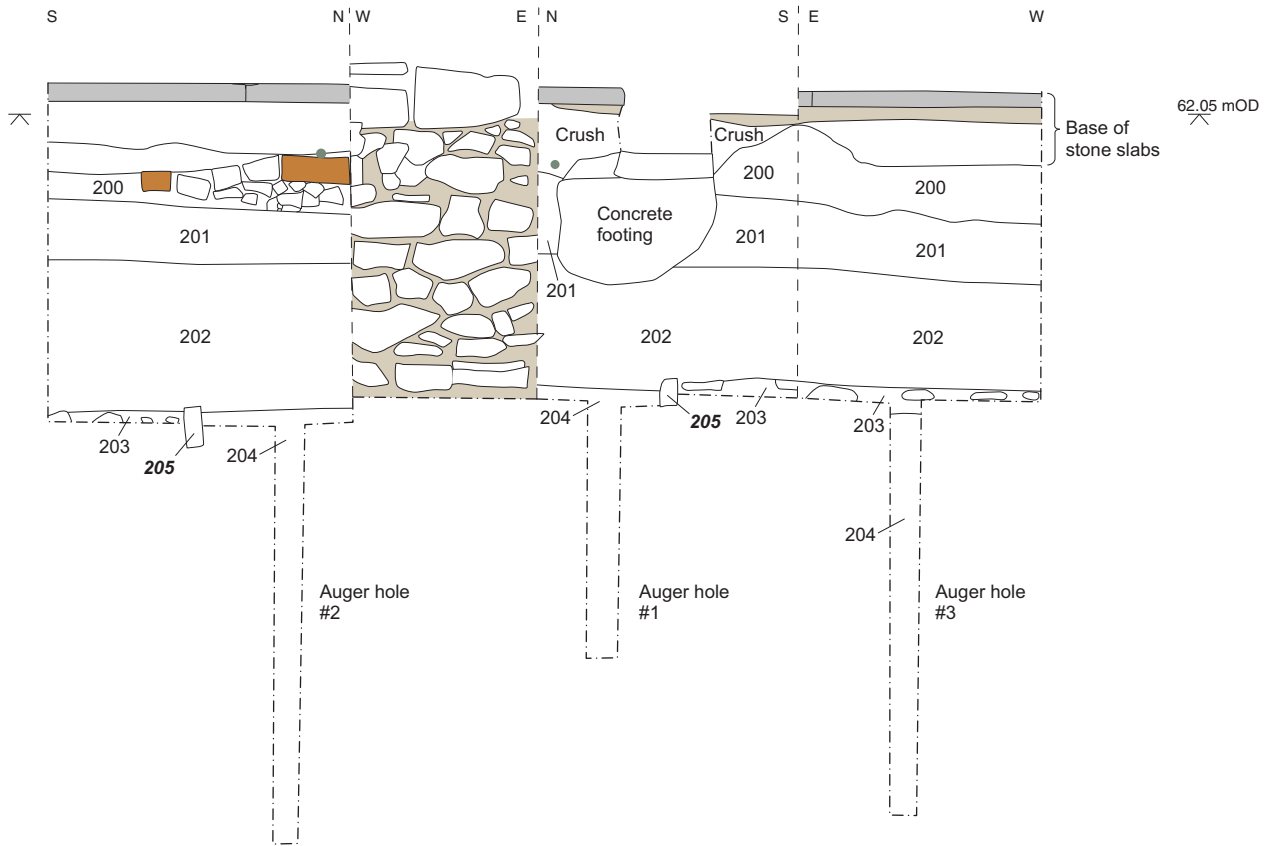

Figure 6: Trench 2, section 200

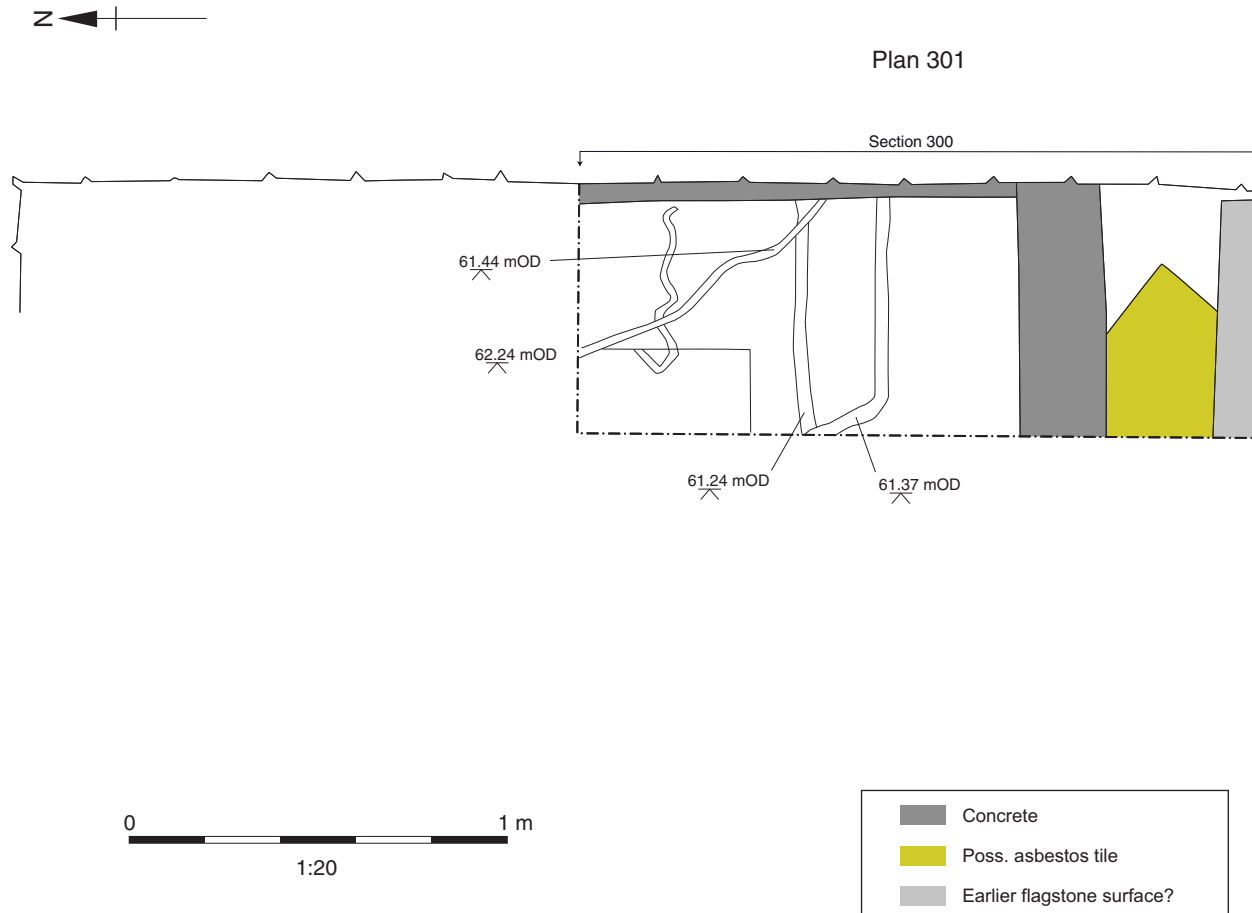

Figure 7: Trench 3, post-ex plan (plan 301)

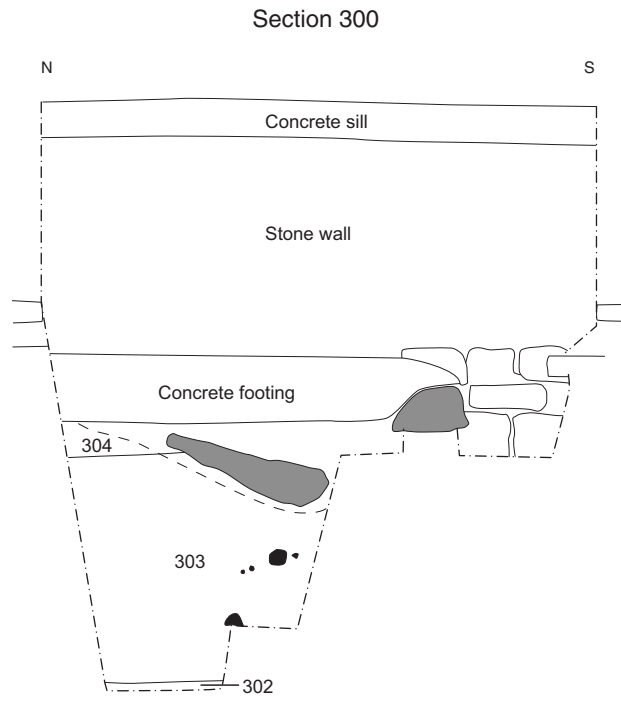
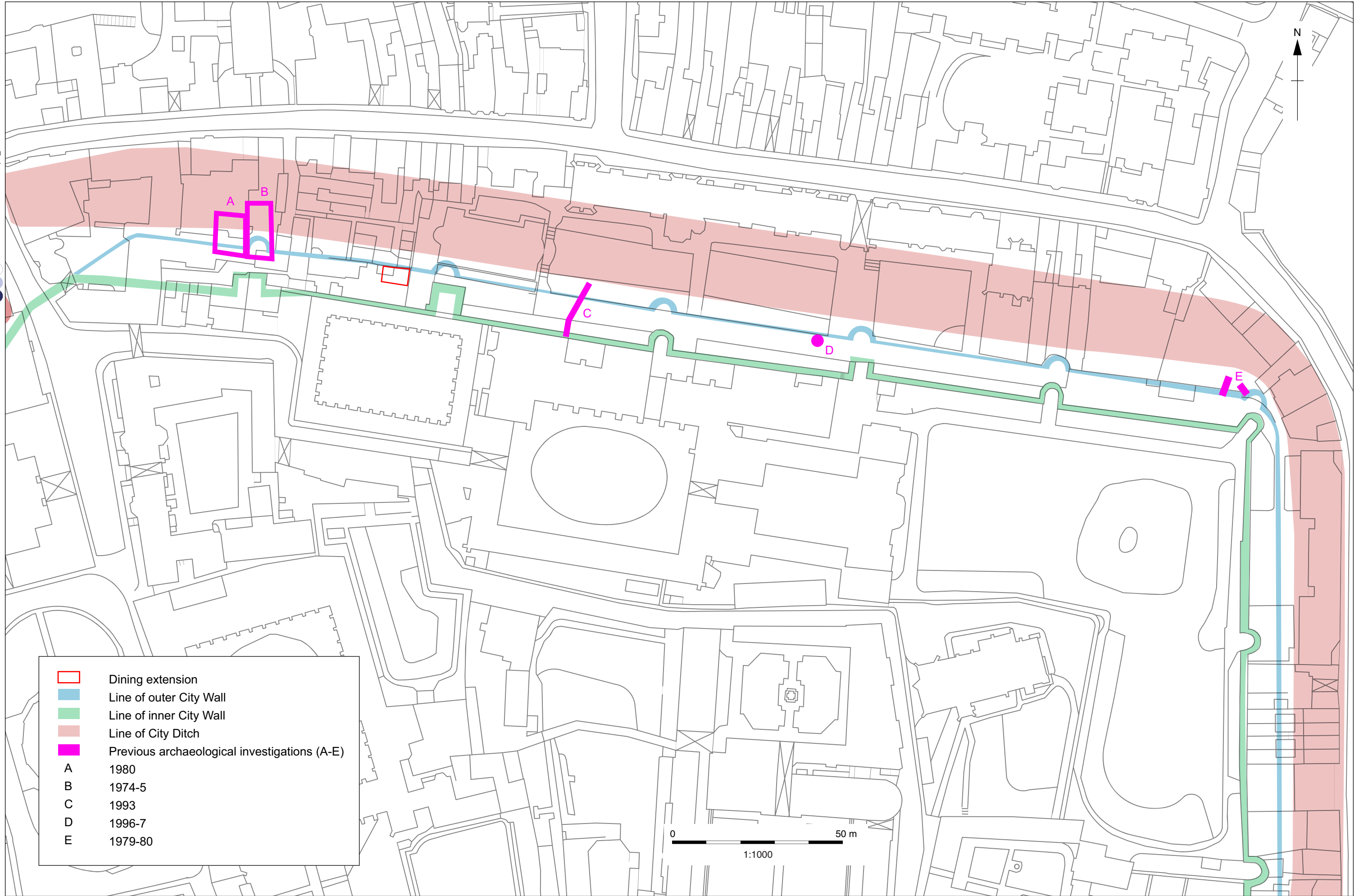

Figure 8: Trench 3, section 300



	Dining extension
	Line of outer City Wall
	Line of inner City Wall
	Line of City Ditch
	Previous archaeological investigations (A-E)
A	1980
B	1974-5
C	1993
D	1996-7
E	1979-80

Figure 9: City Defences



Existing boundary with New College

NOT TO SCALE

Figure 10: OS 1st Edition 1876



**Head Office/Registered Office/
OA South**

Janus House
Osney Mead
Oxford OX2 0ES

t: +44 (0) 1865 263 800
f: +44 (0) 1865 793 496
e: info@oxfordarchaeology.com
w: <http://oxfordarchaeology.com>

OA North

Mill 3
Moor Lane
Lancaster LA1 1QD

t: +44 (0) 1524 541 000
f: +44 (0) 1524 848 606
e: [oanorth@oxfordarchaeology.com](mailto: oanorth@oxfordarchaeology.com)
w: <http://oxfordarchaeology.com>

OA East

15 Trafalgar Way
Bar Hill
Cambridgeshire
CB23 8SQ

t: +44 (0) 1223 850500
e: [oaeast@oxfordarchaeology.com](mailto: oaeast@oxfordarchaeology.com)
w: <http://oxfordarchaeology.com>



Director: Gill Hey, BA PhD FSA MIFA
*Oxford Archaeology Ltd is a
Private Limited Company, N^o: 1618597
and a Registered Charity, N^o: 285627*