

# Gainsborough Building Bath



## Archaeological Evaluation Report



December 2006

**Client: Bath Hotel and Spa  
Co. Ltd**

Issue N<sup>o</sup>: 1  
OA Job N<sup>o</sup>: 2947  
NGR: ST7496 6460

The Proposed Gainsborough Thermal Spa Hotel, Beau Street, Bath  
***ADDENDUM TO AN ARCHAEOLOGICAL EVALUATION REPORT***

**CONTENTS**

Summary.....	3
<b>1 INTRODUCTION .....</b>	<b>3</b>
1.1 Location and scope of work .....	3
1.2 Geology and topography .....	3
1.3 Archaeological and historical background.....	4
1.4 Acknowledgements .....	4
<b>2 EVALUATION AIMS .....</b>	<b>4</b>
2.1 General .....	4
<b>3 EVALUATION METHODOLOGY .....</b>	<b>4</b>
3.1 Scope of fieldwork .....	4
3.2 Fieldwork methods and recording.....	5
3.3 Finds .....	5
3.4 Palaeo-environmental evidence.....	5
3.5 Presentation of results .....	5
<b>4 Results: General .....</b>	<b>5</b>
4.1 Soils and ground conditions .....	5
4.2 Distribution of archaeological deposits.....	6
<b>5 Results: Descriptions.....</b>	<b>6</b>
5.1 Trench 7 extension.....	6
5.2 Trench 10.....	7
5.3 Trench 11.....	8
5.4 Trench 12.....	8
<b>6. ARTEFACTS AND ECOFACTS .....</b>	<b>9</b>
6.2 Pottery .....	
<b>7. DISCUSSION AND INTERPRETATION.....</b>	<b>9</b>
7.1 Reliability of field investigation.....	9
<b>8. DISCUSSION .....</b>	<b>9</b>
8.1 Trench 7 ext.....	9
8.2 Trench 10.....	10
8.3 Trench 11.....	10
8.4 Trench 12.....	10
8.5 Depth of deposits and foundations in the south range.....	11
8.6 Proposed excavations for pools.....	11
9 Conclusion.....	12
Appendix 1 Archaeological Context Inventory .....	13
Appendix 2 Pottery .....	14

Appendix 3 Bibliography and references..... 15  
Appendix 4 Summary of Site Details..... 15

**LIST OF FIGURES**

Figure 1 ..... Site location  
Figure 2 ..... Trench location and previously recorded archaeological remains  
Figure 3 ..... Trench sections and plans

**LIST OF PLATES**

Plate 1 ..... Trench 7 extension after excavation of 712, and partial removal  
of foundation 716 looking west.  
Plate 2 ..... Trench 10, deep wall footings and adjacent deposits, looking north

## SUMMARY

*In November 2006 Oxford Archaeology (OA) carried out an additional investigation to the field evaluation carried out in June at the Gainsborough Building, Beau Street, Bath (NGR ST74966460) on behalf of Bath Hotel and Spa Ltd. The work consisted of four trenches. One was an extension of one of those dug in June and the other three were new. The trenches were intended to provide information to confirm that the archaeological impact of foundation and pool design of the proposed development of the Gainsborough Building be mitigated successfully by the design proposals contained in the evaluation report. Two trenches were dug to investigate the depth of the footings of the southern range fronting Lower Borough Walls, and two were opened to confirm the presence and depth of archaeological deposits in areas that be affected by the construction of the intended pools. It was found that the depths and character of the deposits in the original evaluation trenches could be considered typical. The results of the southern two trenches were less clear. Investigations along the southern wall were confused by the presence of probably 18th century footings and more Roman remains, preventing fuller interpretation. The northern foundations were over 2.6 metres deep, but archaeological deposits continued to at least the same depth. Nonetheless, by comparing the known and extrapolated depths of the pre-Roman ground surface in the vicinity, a strong case can be that the footings of the existing buildings do continue into the natural strata and that the base of the archaeological deposits are not likely to be more than about 0.30 metres below the base of the deepest trench.*

## 1 INTRODUCTION

### 1.1 Location and scope of work

- 1.1.1 In June and July 2006 OA carried out a field evaluation at the Gainsborough Building, Beau Street Bath, formerly part of the Bath College of Further education and originally built as the (Royal) United Hospital (NGR ST74966460) on behalf of Bath Hotel and Spa Ltd. The work was in respect of a proposal for the development of the existing building for hotel use.
- 1.1.2 No brief was issued for the work by the local planning authority, but the work was carried out as a further part of the engineering investigation for foundation design after discussions with the B&NES Archaeological Officer.
- 1.1.3 The development site is situated in the centre of Bath adjacent to the Hot Bath Spring and is 0.1867 hectares in area (Fig. 1). It is bounded by Lower Borough Walls, Bilbury Lane, Beau Street and Hot Bath Street (Fig. 2).
- 1.1.4 The results of that piece of work were reported on in OA2006a. Further information was required to support the mitigation strategy proposed and to confirm the interpretation of the deposits in the north and centre of the site. OA were commissioned to excavate four more trenches to provide this information.
- 1.1.5 Trench 7 of the original series was extended to the south wall of the southern range, and three new trenches, 10, 11 and 12 were excavated and numbered in the series already established (Fig. 2).

### 1.2 Geology and topography

- 1.2.1 The underlying geology consists of Holocene alluvium over Pleistocene river gravels and sands over Lias clay. At the Spa site, north of Beau Street, the two latter phases rarely amounted to more than 1.5 m together in thickness. The alluvium lies at c. 18 m to 17 m OD and slopes gently

from north to south. It has probably been removed over much of the site by Roman building works. Present street level is at 22.15 m OD at Lower Borough Walls.

- 1.2.2 The site is in the centre of modern Bath and near the south east corner of the walled area of Roman and medieval Bath. Bath itself lies in the bottom of the Avon valley and the site is on the north side of the valley floor on a shallow, south-facing slope, rising slightly from the valley bottom itself. The site is currently occupied by the Gainsborough Building which is a multi-period building erected in three major campaigns in the 19th century, during which it grew to occupy the entire island site of the present proposed development.

### 1.3 Archaeological and historical background

- 1.3.1 The archaeological background to the evaluation has been the subject of a two separate desk-based studies (Davenport 2003 and 2005), the results of which were summarised in OA2006A and will not be repeated here. However, the basic archaeological background is that there are many known sites with archaeological remains in the close vicinity of the development site.

### 1.4 Acknowledgements

- 1.4.1 OA would like to thank John Mann and Tim Coldwell of Mann-Williams Civil Engineers for their help with design proposals and the practicalities of excavation and access to the building. Richard Sermon, Archaeological Officer for B&NES who provided useful discussion on the WSI and made helpful comments on site and afterwards. The evaluation was carried out by Kim Watkins (independent archaeological consultants) and managed by Peter Davenport for Oxford Archaeology.

## 2 EVALUATION AIMS

### 2.1 General

- 2.1.1 To establish the depth of the upper limit of significant archaeological deposits under the 1825 block and under the central studio area.
- 2.1.2 To further characterize determine the character of the archaeological deposits under the central studio area.
- 2.1.3 To establish the depth of the Victorian footings where it is proposed to set the new piled foundations of the southern range of the proposed building and their relationship to buried archaeological deposits.
- 2.1.4 To determine the potential for preservation *in situ* of significant archaeological remains, should they be present.
- 2.1.5 To make available the results of the investigation.

## 3 EVALUATION METHODOLOGY

### 3.1 Scope of fieldwork

- 3.1.1 The work was originally planned to consist of four test pits. Two were sited to investigate the north and central area deposits (Trenches 11 and 12) and two were dug to investigate the foundations of the north and south walls of the southern range along Lower Borough Walls (Trenches 7 and 10, Fig. 2).

- 3.1.2 The Trench 7 extension was, in fact, a second attempt to site the trench, as an original position to the west hit both a large, apparently Roman masonry construction and modern concrete underpinning, both of which prevented further investigation.
- 3.1.3 The concrete floors and make-up were removed by contractors under archaeological supervision and recent soils were also excavated by contractors (by hand digging) again under archaeological supervision. The attending archaeologists took over the excavation when deposits predating the 19th century were suspected.
- 3.1.4 As with the original evaluation, trenches were excavated until significant archaeological layers were reached or recognised. Limited excavation into the layers took place where it was necessary to clarify or characterise the deposits.
- 3.1.5 In Trenches 11 and 12 the upper surface of the exposed archaeological horizon in each of the trenches was cleaned and recorded archaeologically and excavation essentially stopped at this point. However, in Trenches 7 and 10 the procedure was varied as the aims of the investigation were a little different.
- 3.1.6 In these trenches it was hoped to show the relationship of the Victorian cellar wall foundations to the layers they were cut through. This meant that archaeological deposits had to be removed to give working room. This was done to a limited an extent as practical.

### **3.2 Fieldwork methods and recording**

- 3.2.1 With the variations mentioned above, techniques were the same as those used in the main evaluation excavation. Recording followed procedures laid down in the *OAU Fieldwork Manual* (ed. D. Wilkinson, 1992).

### **3.3 Finds**

- 3.3.1 Finds were recovered by hand during the course of the excavation and bagged by context. Finds of special interest were given a unique small find number.

### **3.4 Palaeo-environmental evidence**

- 3.4.1 In the context of the excavation of small trenches, the soils could not be sufficiently characterised and dated to make such sampling appropriate.

### **3.5 Presentation of results**

- 3.5.1 The archaeological results from each trench are described individually.
- 3.5.2 Section 5 contains a detailed description of all archaeological observations within each trench, and includes individual context descriptions. General archaeological information is summarised in the trench inventory table (Appendix 1).

## **4 RESULTS: GENERAL**

### **4.1 Soils and ground conditions**

- 4.1.1 The site is located on river alluvium and terrace gravels but these were not reached in the excavations. In Trenches 11 and 12, most of the soils removed were either 19th century dump or earlier post-medieval garden soils. In Trench 10 a considerable depth of silty loams of medieval date were removed but from a narrow sample area.
- 4.1.2 Site conditions were generally dry, as the trenches were all indoors, but the ground remained damp throughout and, therefore, colour and texture definition were good and easily determined.

## 4.2 Distribution of archaeological deposits

- 4.2.1 In the abortive trench west of Trench 7 (Fig. 2) a rectangular masonry mass was revealed just below the concrete floor of the basement. Its character, size and alignment strongly suggested it was a Roman buttress, similar to those recorded by Irvine in 1864 (OA2006A, Fig. 2). Its position suggests that it is part of one of the walls recorded by Irvine belonging to an earlier phase Roman building. It is essentially of uncertain date, however.
- 4.2.2 The extension to Trench 7 showed the post-medieval footing continuing south, cut into what was felt from the finds, to be a Roman or early post-Roman deposit. A straight and vertically-sided feature cut across this layer on what might be thought to be the Roman alignment and contained exclusively Roman material.
- 4.2.3 The foundations of the southern wall cut through this wall. They were of rubble in hard mortar and were traced to a depth of 1.63 m, where it seemed they came to an end. However, it is possible that these were older foundations reused and as they projected northwards as much as 0.80 m, it may be that the 19th century wall footings continued at depth past the south face of these foundations.
- 4.2.4 Trench 10 showed that the deposits under the floors here are of considerable depth. Excavation reached 2.3 metres below the current basement floor without reaching natural gravel or alluvium. The Victorian footings continued downwards beyond the limit of excavation.
- 4.2.5 The upper 0.60 m of the deposits are the concrete floor and its make-up and below this, another metre of deposits are probably medieval and/or early post-medieval. At this depth and downwards, but penetrated by probably medieval rubbish pits, the deposits are most likely to be Roman.
- 4.2.6 Trench 11 indicated that Trench 5 from the original evaluation was typical in showing depths of medieval occupation or garden soils starting near the surface, although here the topmost layers appeared to be post-medieval in date.
- 4.2.7 Trench 12 confirmed that the disturbance of the deposits shown in Trench 2 was typical but also revealed the footings for the original stepped-back rear wall of the south west corner of the Pinch block, as it was before the alterations of 1864-6.

## 5 RESULTS: TRENCH DESCRIPTIONS

### 5.1 Trench 7 Extension (see Section A and Plans A and C)

- 5.1.1 This trench was an extension of the original Trench 7 1.84 m southwards, meeting the southern wall (on Lower Borough Walls) of the building (Fig. 2). The trench was excavated to examine the depth of archaeological deposits relative to the footings of the 1890's wall (Fig. 3).
- 5.1.2 This part of the trench was excavated to a maximum depth of 1.64 m below the current floor level (floor at 20.06 m AOD). The earliest deposit recorded was mid-brownish grey, silty clay (720), which contained occasional flecks of Romano British (RB) tile, occasional oyster shell and pieces of stone tile. This was overlain by a mottled gritty grey clay deposit (719), containing occasional small sub-angular pieces of limestone, oyster shell, charcoal, RB pottery and tile flecks, 0.18 m thick. Above this was a thin layer of soft reddish brown clay (718), with occasional small stones, RB pottery, charcoal, and tile flecks. This was overlain by mid brownish grey clay (722) 0.48 m deep, visible in section but not excavated. This layer contained frequent lenses of small rubble and stone, and should probably be divided into several smaller contexts. Above this was a firm

brownish yellow clay (708), which was 0.12 m deep in this area, and has been recorded in the previous evaluation. This layer or surface had been cut by a very straight edged feature [712], the eastern edge of which lay on a north-south alignment. The eastern side of the cut was vertical with a sharp break of slope at the top and bottom, and the base was flat. The lowest fill of this cut was a mottled greyish brown clay (717) up to 0.34m deep, containing frequent flecks of stone and charcoal and occasional RB pottery, tile and oyster shell. There were also common inclusions of sub angular limestone rubble in this layer, which appeared to be lying on the base of the feature. Above this was a thin layer of soft reddish brown clay (715) with frequent charcoal flecks and occasional RB pottery. This was overlain by a layer of mottled brownish grey clay (714), flecked with stone and containing frequent RB pottery and tile, bone, pieces of iron and frequent charcoal. Overlying this was a similar deposit (713) with occasional large sub angular pieces of limestone. This was the upper fill of cut [712] and was 0.3m deep, with frequent charcoal and occasional RB pottery.

- 5.1.3 Layer 708 was also cut by a wall footing trench, 711 which contained the footings for a wall thought in the previous report to be part of the early 18th century Baves House. Its relationship to the footing 716 will be returned to in the discussion.
- 5.1.4 Cutting through all these layers was the footings trench for an 18th or 19th century wall [721], running on a roughly east-west alignment, to a depth of 1m. This cut contained footing (716), which comprised pieces of pennant and limestone and occasional large limestone slabs in a hard mortar matrix. These footings seemed to continue underneath the existing wall, but projected north of them by 0.80 m and were therefore interpreted as pre-1860s in date.
- 5.1.5 Overlying context (716) there was a thin layer of mortar (704), as recorded in the previous phase of evaluation This was then overlaid by contexts (703), (702) and (701) which were the same 19th century make-up layers recorded on the previous evaluation, overlain by a concrete floor.

## 5.2 Trench 10

- 5.2.1 This new trench was located on the southern side of the building in an area originally occupied by the 'Dead House'. The trench was 2 m long by 1.4 m wide, narrowing to *c.* 0.50 m below 0.60 m, and was excavated against the southern face of the original north wall to investigate the depth of archaeological deposits in relation to the footings of the existing 19th century wall (Figs. 2 and 3).
- 5.2.2 The trench was excavated to a maximum depth of 2.3 m below floor level against the wall footings (17.77 m AOD). The earliest deposit appeared to be context (1011), which was limestone rubble in creamy yellowish decayed mortar. This was at least 0.25 m thick (and may be much thicker), and had an un-abraded sherd of RB pottery within it. The rubble deposit appeared to have been cut by a steep sided feature [1012], possibly a pit up to 0.6 m deep. This was filled with a soft mid brown silty clay loam (1010) containing occasional un-abraded RB pottery and tile. Above this was a similar layer of mid brown silty clay loam (1008) containing occasional small limestone fragments and charcoal, 0.29 m deep. This was overlain by a thin layer of limestone flecks and grit in a matrix of orangey brown clayey silt (1007). This context was 0.1 m thick and contained frequent stone gravel in some cases resembling RB mortar. Above this was a dark greyish-brown, silty clay (1009) containing occasional animal bone, over 0.2 m in thickness. This was overlain by a similar layer (1006) which had a slightly less friable texture and was 0.26 m deep. A more stony layer (1006) was above this, similar to (1007) but only 0.04 m thick. Above this was a dark greyish-brown, silty clay loam soil (1004) 0.44 m deep, with occasional late medieval or early post-medieval pottery inclusions.



5.2.3 The footings trench for the wall of the 19th century Dead House [1013] had cut all layers below 1002, and was barely wider than the wall footing itself. There was some evidence near the base of the excavated sondage that the sides of this footings trench had partially collapsed during construction, and the holes in the side of the excavation had had to be packed with rubble. The foundations of wall (1014) continued to a depth of over 2.3 m below floor level. These were constructed from Bath stone blocks to a depth of 1.3 m, below which they were rubble and mortar, forming a soft concrete which had been poured into the foundation trench cut; the base was not found.

5.2.4 A layer of mixed soil (1002) with frequent mortar and small limestone fragments overlay footings (1014) and abutted the wall. This was overlain by a rubble floor make-up layer (1001), which directly underlay a layer of concrete flooring covered by a finer screed layer. These were later 19th and 20th century.

### 5.3 Trench 11

5.3.1 This trench was 1.3 m long by 0.9 m wide and located in the central part of the building. The trench was excavated to investigate the type of deposits that survive in this area (Fig. 2).

5.3.2 The trench was excavated to a maximum depth of 0.58 m (19.46 m AOD), where a compacted uneven layer (1104) was recorded dipping steeply northwards at the northern edge of the excavated sondage. This context was not excavated but its upper surface contained frequent charcoal and iron (Fe) slag, and pottery of probable Late medieval date. Overlying this was a layer of dark greyish brown gritty soil (1103) up to 0.12m thick, with occasional stones, Fe slag, abraded pottery and charcoal. Above this was a similar but slightly looser and darker deposit (1102) 0.18 m thick, which contained occasional mortar and bone but no dating material (Fig. 3). These contexts were overlain by another similar, but more disturbed layer (1101) with occasional mortar lenses and brick fragments 0.1 m deep.

5.3.3 On the northern side the uppermost soil layer (1101) was cut by a straight edged trench [1106] which contained a relatively modern red brick duct (1105), abutted by a loose soil layer (1107). The concrete floor then overlay this.

### 5.4 Trench 12

5.4.1 This trench was 1.6 m by 1.3 m and was located in the original 1830's building. The trench was excavated to investigate the depth of deposits in the north-western corner of a proposed new pool (Fig. 2).

5.4.2 The trench was excavated to a maximum depth of 1.36 m (18.9 m AOD). The earliest feature recorded was (1205) a solid Bath stone structure the northern edge of which was recorded on an east-west alignment (Fig. 3). This structure was over 1.2m by 1.2m and 0.7m deep and the base was not found. It was recognised as the foundations of the south wall of the inset south-west corner of the 1826 building, rebuilt on its present alignment in the 1860's. This was abutted by 19th century make-up layer (1204), a loose dark brown soil with frequent rubble and lenses of mortar over 0.6m deep. Overlying (1204) was a thin layer of soft cream mortar (1203) which also abutted (1205). Above this there was a loose mortar and rubble floor make-up layer (1202) which had been laid on top of wall footing (1205) after it had been demolished during the later 19th century. Overlying this was a very loose layer of broken pennant slabs and brick rubble (1201), which directly underlay the concrete floor.

## **6 ARTEFACTS AND ECOFACTS**

### **6.1 General**

6.1.1 A summary of the pottery finds can be found below. A full listing of the Roman pottery can be found in Appendix 2.

### **6.2 Pottery**

- 6.2.1 Roman pottery was recovered from Trench 7. Along with the lack of medieval pottery this confirmed the Roman or early post Roman date of the pre-19th century deposits here. The collection, though small, all came from one feature (712), and was typical of Bath sites, with Black-Burnished 1, Oxfordshire and Severn Valley ware, along with local grey wares and central Gaulish Samian. As a collection, the pottery was all post AD250 but contained material that could be second century or earlier, indication that earlier occupation probably occurred on the site.
- 6.2.2 In Trench 10, one sherd was recovered from 1011, thought to be a Roman demolition deposit. This was a colour coat vessel, probably an Oxford ware, but in use throughout the Roman period. Another sherd of BB1 ware was recovered from 1010, the fill of a post-Roman pit cut through 1011, and probably deriving from it. This was similarly broadly dated, as was one final sherd found in the 19th century floor make-up.
- 6.2.3 Roman pottery was found in Trench 11, but was clearly residual in the medieval layers.
- 6.2.4 No pottery was found in the dark soils in Trench 10, suggesting an pre-Norman Conquest date, although the pottery from Trench 8 in the main evaluation was retrieved from layers equivalent to the upper ones in trench 10.
- 6.2.5 Pottery in use in the late 11th to the early 13th century was found in Trench 11, comparable to that in Trench 5. Most of this was local ware but one probably Winchester-type fragment was noted.

## **7 RELIABILITY OF FIELD INVESTIGATION**

- 7.1.1 The evaluation took the form of the excavation of four hand-dug test pits. Finds were abundant enough to judge intuitively the likelihood of residuality. Intrusion of later material into earlier deposits was a strong theoretical possibility given the history of this site. Therefore, layers thought likely on finds and stratigraphic grounds to be medieval were very likely to be so in the absence of later pottery or artefacts, abundant in later layers.
- 7.1.2 Some excavation into the pre-19th century contexts took place with the consent of the B&NES Archaeological Officer. This was in order to achieve the aim of investigating the footings of the existing building.

## **8 DISCUSSION**

### **8.1 Trench 7 extension**

- 8.1.1 The trench was first sited to the west of Trench 7 but hit both modern concrete additions to the southern wall, and a substantial masonry construction just below the concrete floor (Fig. 2). Together, these elements prevented the further execution of the investigations here.
- 8.1.2 The concrete seemed to be something to do with alterations to the southern wall of later 20th century date. The masonry structure was not further investigated but its alignment and position made it very likely that this was a part of the Roman buildings recorded in 1864. As it was only just beneath the floor and beyond the footprint of the 1864 "Dead House and Dissecting Room",

it seems that this area, outside the development of that period, has archaeological remains unaffected by the truncation caused by that work.

- 8.1.3 With this in mind, the investigation was changed to extending Trench 7 (OA2006a) just within the west end of the 1864 building. The late or post-Roman surface 708, found in June, was encountered as was the post-medieval wall footing 709, below the disturbance layers of 1864. Features were cut into this, containing only Roman pottery.
- 8.1.4 Cutting across everything at the southern end was a hard mortared rubble foundation, aligned roughly east-west, the same as the current building (Plate 1). This projected north of the internal wall line of the present building by as much as 0.80 m. It could not be proved to run under the wall more than a few centimetres as it obscured any wall face behind it, which it was not safe to cut into. It came to an end at a depth of 1.6 m below cellar floor.
- 8.1.5 It seems very likely that this footing is an earlier structure, perhaps the Bave house front wall, although it appears to either cut or be abutted by the other post-medieval footing 709, now thought to be an internal wall of the Bave house. It has, therefore, not been possible to ascertain the depth of the wall footing of the current building nor the depth of the archaeological deposits, except to say that the latter extend from 0.6 m to at least 1.63 m below the cellar floor.

## **8.2 Trench 10**

- 8.2.1 In this area the same dark soils that were seen in the adjacent Trench 8. They were traced to a depth of 1.6 metres below the floor or 1.3 metres below the floor make-up (Plate 2). They seemed to be of medieval origin, although the upper level may well be post-medieval. Below 1.6 metres it appeared that the deposits were Roman, on the basis of sparse finds but also the character of the material, and its depth. The Roman deposit was at least 0.6 m and possibly 0.7 m thick but its base was not found.
- 8.2.2 The foundation of the Victorian wall was of coursed, roughly squared work down to 1.4 metres and below this, consisted of poured, not very coherent, weak mix with a very coarse aggregate with large voids. It too was not bottomed but could be seen to continue past 2.3 metres below the cellar floor.
- 8.2.3 The depth of the post-Roman stratified deposits was surprising, with the Roman level here being nearly a metre deeper than that in Trench 7. This may be due to a local truncation of the Roman deposits in the middle ages.
- 8.2.4 The foundations here are of the 1864 work and their depth is consistent with those shown on drawings of the time (e.g. Davenport 2003, fig. 30), although the actual form is certainly formalised on those drawings (which are architects' not engineers' or builders').

## **8.3 Trench 11**

- 8.3.1 This small trench confirmed that the soils predating the construction of the studios were still intact. Unlike with Trench 5, the very top layers appeared to be post-medieval, and medieval layers only survived about 0.40 to 0.50 m below the cellar floor. A brick conduit ran across the corner of the trench, a reminder that the top levels under the floor will be criss-crossed with recent services.

## **8.4 Trench 12**

- 8.4.1 This trench came down squarely on the massive foundation of the original rear wall of the 1825 block, which, here, was set back from its present position, which dates from 1864. On the side

that was possible to excavate, the same disturbance down to more than 1.3 metres was recorded as had been seen in Trench 2.

## **8.5 Depth of deposits and foundations in the south range**

- 8.5.1 The trenches along the south range were dug to try to clarify the depth and character of the foundations here. In this it was partly successful. The north wall was traced down to 2.3 metres below the cellar floor in Trench 10 or 17.67 m OD. The south wall was apparently masked by an earlier foundation that it probably partly re-used (Trench 7). Archaeological deposits were found down to the full depth of the excavations or 17.67 m OD in Trench 10 and 1.63 m below cellar floor or 18.33 m OD in Trench 7.
- 8.5.2 Predictions of the depth of the base of archaeological deposits are based on two main extrapolations. The first of these is simply extending the profile between the known data from the Spa excavations immediately to the north to the depths to the alluvium seen earlier this year in the Avon Street campus of the Bath College of Further Education to the south (OA 2006b). This predicts that the pre-Roman ground surface (PRGS) will be at about 2 m below the cellar floor at the south side or 18 m OD (Davenport 2005, Fig. 7). As this level is found at 18.33 m in Bellott's Hospital next door but further north, it may underestimate the depth.
- 8.5.3 The other method is to inspect the contour map of the pre-Roman ground surface under central Bath prepared by Bath Archaeological Trust on the basis of all available archaeological investigations that had plotted this level. The Gainsborough Building falls almost exactly between the 18 m contour at the north-east corner and the 17 m contour at the south-west corner. Because of the angle of the contours, the best estimate is that the pre-Roman ground surface at this part of the site should fall at about 17.25 to 17.5 m OD.
- 8.5.4 Trench 10 shows that the deposits here go down to at least 17.77 m OD and that the foundations follow to at least that depth. It is therefore very likely that there is a very small depth, perhaps 0.20 – 0.30 m of archaeological deposit below the limit of excavation in Trench 10 and that it is extremely unlikely that the wall footings do not continue into the natural strata.
- 8.5.5 While this is not so clearly shown for Trench 7, it must be likely as the wall is part of the same build. Deep archaeological strata of medieval and Roman date survive here but are almost certainly removed along the line of the standing Victorian wall.
- 8.5.6 This means that the method of foundation design proposed for this area in the main evaluation report (OA 2006a, sec. 8 and Fig. 6) would not impinge on any buried remains below the existing footings, as these are likely to have been previously removed.
- 8.5.7 If the remains in the abortive trench west of Trench 7 are indeed Roman, and it looks very probable, then especial care will need to be taken in designing the foundations in this area and it may be that there are implications for the levels of the new floor slab here.

## **8.6 Proposed excavations for pools**

- 8.6.1 It was reported in the main evaluation report that a rectangular bath was proposed in the south-eastern rooms of the 1825 block (OA 2006a, Fig. 6). Trench 2 was dug in the easternmost of these two rooms and showed that in that part of the room there were no deposits pre-dating 1825 above 1.33 m below the floor. Trench 12 was, therefore, dug to confirm this picture and remove uncertainties about the survival of deposits here.

- 8.6.2 As described above, the new trench came down on the footings of the original rear wall of the 1826 block and showed the same depth of disturbance to its north as seen in Trench 2. The creation of a pool here to a depth of 1.3 metres, will not therefore impact on any archaeological remains.
- 8.6.3 Trench 11 was dug to confirm the results from Trench 5. In general terms, it did so, but indicated, perhaps not surprisingly, that the deposits are likely to be more varied in date. The trench did show, however, that the deposits, of medieval to post-medieval date seem to survive under the floors of the existing studio block. A caveat to this is that relatively recent conduits, as shown in Trench 11 may have dissected the uppermost levels.
- 8.6.4 It is clear that the creation of a pool in this area will require careful consideration of mitigation procedures. Currently it is proposed to build above the level of the archaeological strata and to utilise multiple small bore drainage to reduce this impact. (OA 2006a, para 8.2.1.2). Any excavation for new drainage will be mitigated either by design or archaeological record.

## **9 CONCLUSION**

- 9.1.1 The excavations supported the predictions made in the original report about the levels of archaeological survival, the impacts and the mitigation proposals, although the results from the investigations into the foundations of the south range were not so definitive as had been hoped. However, they did provide enough information to suggest that the foundation design proposed for this area in the main evaluation is still appropriate.
- 9.1.2 The apparent existence of substantial Roman masonry just below the floor west of Trench 7 means that the especial care already recognised as necessary in confirming the nature and date of this masonry and in designing the detail of footings and floor slabs in the vicinity of the Albert wing will also have to be employed in this area..
- 9.1.3 The creation of pools in the area of Trenches 2 and 12 to a depth of 1.3 metres will not impact on any archaeological remains.
- 9.1.4 The creation of a pool in the area of Trenches 5 and 11 may require more careful analysis, although, as the top levels are in places cut through by recent services, there may well be areas where the deposits are not as well preserved.

**APPENDIX 1 ARCHAEOLOGICAL CONTEXT INVENTORY**

<b>BAGAB 06</b>	<b>Bath</b>	<b>Gainsborough Hotel</b>		
<b>Context</b>	<b>Description</b>	<b>Depth</b>	<b>Thickness</b>	<b>Comments</b>
Trench 7 ext				
712	Straight edged cut	0.62m	0.67m	RB / Early med
713	Mottled greyish brown clay	0.62m	0.32m	Fill of 712
714	Mottled brownish grey clay	0.8m	0.1m	Fill of 712
715	Soft reddish brown peaty clay	0.9m	0.16m	Fill of 712
716	Wall footings mortar and stone	0.58m	1m	19th c footings
717	Mottled greyish brown clay	0.94m	0.34m	Fill of 712
718	Soft reddish brown organic clay	1.22m	0.08m	RB layer
719	Brownish grey gritty clay	1.32m	0.18m	RB layer
720	Brownish grey silty clay	1.52m	min 0.14m	RB layer
721	Linear cut EW	0.58m	1m	Cut for footings 716
722	Brownish grey stony clay	0.72m	0.48m	RB layer
Trench 10				
1000	concrete floor	0m	0.18m	19th/ 20th
1001	Rubble with Bath stone pieces	0.18m	0.14m	19th/ 20th
1002	Soil with mortar and stone	0.32m	0.24m	floor make up 19th c
1003	Reddish brown soil with limestone dust	0.32m	0.08m	floor make up 19th c
1004	Dark greyish brown silty clay loam	0.6m	0.4m	Late med-early p/med
1005	Limestone and grit	0.78m	0.015m	mortar lens P med?
1006	Dark greyish brown silty clay loam	0.8m	0.38m	Late med /med ?
1007	Limestone and grit	1.2m	0.1m	mortar lens P med?
1008	Brown silty clay loam	1.28m	0.28m	Medieval layer ?
1009	dark greyish brown silty clay loam	1.27m	min 0.24m	Medieval layer ?
1010	Brown silty clay loam	1.6m	0.6m	Fill of 1012 ?
1011	Stone rubble and mortar	1.6m		RB rubble
1012	Probable cut	1.59m	0.6m	Post RB cut?
1013	Narrow linear cut	0.61m		Footings trench for wall 1014
1014	Wall foundations EW			North wall of "Dead House"
Trench 11				
1100	Concrete	0m	0.18m	20th c floor
1101	Dark blackish brown soil	0.18m	0.05m	Post med soil
1102	Dark blackish brown gritty soil	0.28m	0.09m	Late med / early p med
1103	Dark greyish brown gritty soil	0.44m	0.12m	Late med soil

1104	Compacted layer with Fe slag	0.54m	n /a	Late med surface?
1105	Red brick structure	0.23m	0.13m	20th c duct
1106	Linear cut NE by SW	0.21m	0.13m	cut for 1105
1107	Loose soil and brick	0.21m	0.13m	fill of 1106
Trench 12				
1200	Concrete	0m	0.16m	19th /20th c floor
1201	Loose rubble, pennant and brick	0.16m	0.24m	19th /20th c floor make up
1202	Loose mortar, soil and rubble	0.43m	0.3m	19th c make up
1203	Cream mortar	0.66m	0.07m	19th c make up
1204	Dark brown soil, mortar and rubble	0.76m	min 0.5m	19th c make up
1205	Bath stone structure	0.62m	min 0.7m	19th c foundation

## APPENDIX 2 POTTERY

### Dan Stansbie

<b>Ctx</b>	<b>Sherd count</b>	<b>Weight (g)</b>	<b>Comments</b>	<b>Spot Date</b>
713	14	126	R30 sandy grey ware, B11 (BB1) 1 cooking jar, 1 plain rimmed dish with handle, S30 central Gaulish samian, M40 Oxfordshire red-slipped mortaria, O40, Severn valley ware ( 1 tankard/carinated beaker), Q10 oxidised white slipped ware	250+
714	7	66	R30 sandy grey ware, O40 Severn Valley ware (1 plain rimmed dish)	250+
715	1	22	O40 Severn Valley ware	43-410
717	5	62	R30 sandy grey ware, W11 Oxfordshire parchment ware	270-410
719	1	4	S30 central gaulish samian (1 form 18/31	120-150
1003	6	40	R30 (1 plain rimmed dish)	

1010	1	26	Q30 white slipped reduced fabric	43-410
1011	1	16	B11 (BB1)	43-410
1103	1	22	R30 sandy grey ware (1 handle)	43-410
1104	2	10	C10 shelly fabric, F51 Oxfordshire colour-coated ware	270-410

The medieval pottery was identified by John Cotter of Oxford Archaeology, but has not yet been fully written up.

### APPENDIX 3 BIBLIOGRAPHY AND REFERENCES

- Booth, P, nd *Oxford Archaeology Roman pottery recording system*, Oxford Archaeology, unpublished (revised January 2006)
- Davenport, P. 2003 The City Of Bath College. An Archaeological and Historical Desktop Assessment. Unpublished Planning Document B&NES SMR
- Davenport, P. 2005 The Gainsborough Building, Beau Street, Bath: An Archaeological Desktop Assessment. Unpublished Planning Document B&NES SMR
- McCarthy, M. R. and Brooks, C. M. 1988 *Medieval Pottery in Britain AD900-1600* Leicester University Press
- Mellor, M. 1994 Oxford Pottery: A Synthesis of middle and late Saxon, medieval and early post-medieval pottery in the Oxford Region *Oxoniensia* **59**, 17-217
- OA 2006a The Proposed Gainsborough Spa Hotel, Beau Street, Bath. Archaeological Evaluation Report. Unpublished Planning Document B&NES SMR
- OA 2006b City of Bath College, Bath, New Performing Arts Building. Archaeological Watching Brief Report. Unpublished Planning report B&NES SMR
- Tomber, R, and Dore, J. 1998 *The national Roman fabric reference collection: a handbook*, MoLAS Monogr **2**
- Vince, A. G. 1984 Late Saxon and Medieval Pottery in Gloucestershire in A. Saville (ed.) *Archaeology in Gloucestershire: Essays Dedicated to Helen O'Neill and the Late Elsie Clifford*, 248 – 75
- Vince, A. G. unpub. *The Medieval Ceramic Industry of the Severn Valley* Unpublished PhD Thesis, University of Southampton, 1984
- Young, C. J. 1977 *Oxfordshire Roman pottery*, BAR Brit. Ser. **43**, Oxford

### APPENDIX 4 SUMMARY OF SITE DETAILS

**Site name:** Bath, Gainsborough Building



**Site code:** BAGAB06

**Grid reference:** NGR SP 026020

**Type of evaluation:** 4 hand excavated test pits

**Date and duration of project:** November 2006 (10 days)

**Area of site:** 0.186 ha

**Summary of results:** The test pits confirmed the representative nature of the test pits in the centre and north of the site carried out in June 2006 by OA. Investigations of the late Victorian foundations showed that they were very deep and probably extended into the natural subsoil, but the relationship to the buried archaeological deposits was not fully resolved.

**Location of archive:** The archive is currently held at OA, Janus House, Osney Mead, Oxford, OX2 0ES, and will be deposited with the Roman Baths Museum, Bath in due course, under the following accession number: BATRM06.xxx

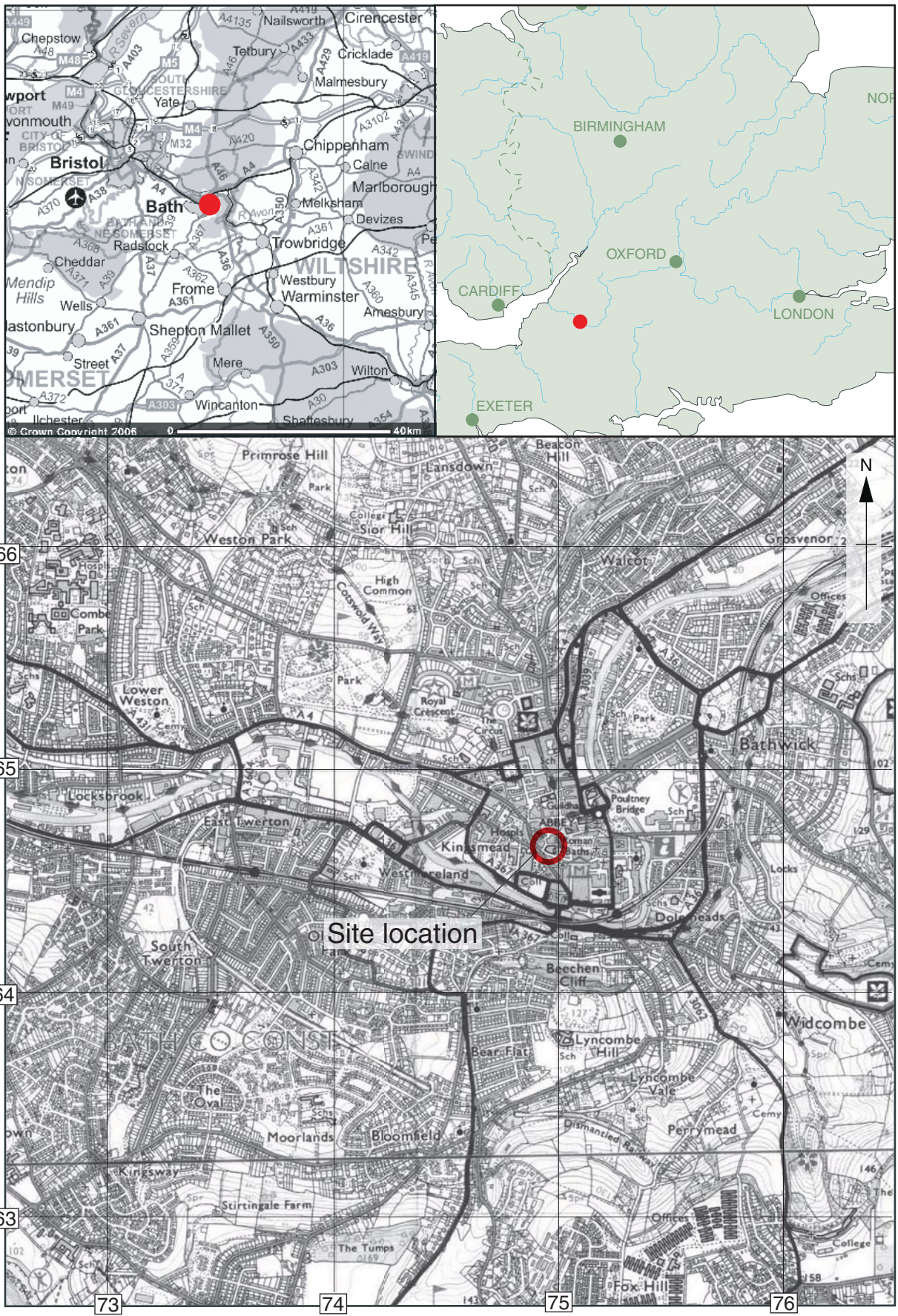

Scale 1:25,000

Reproduced from the Explorer 1:25,000 scale by permission of the Ordnance Survey on behalf of The Controller of Her Majesty's Stationery Office © Crown Copyright 1998. All rights reserved. Licence No. AL 10005569

Figure 1: Site location

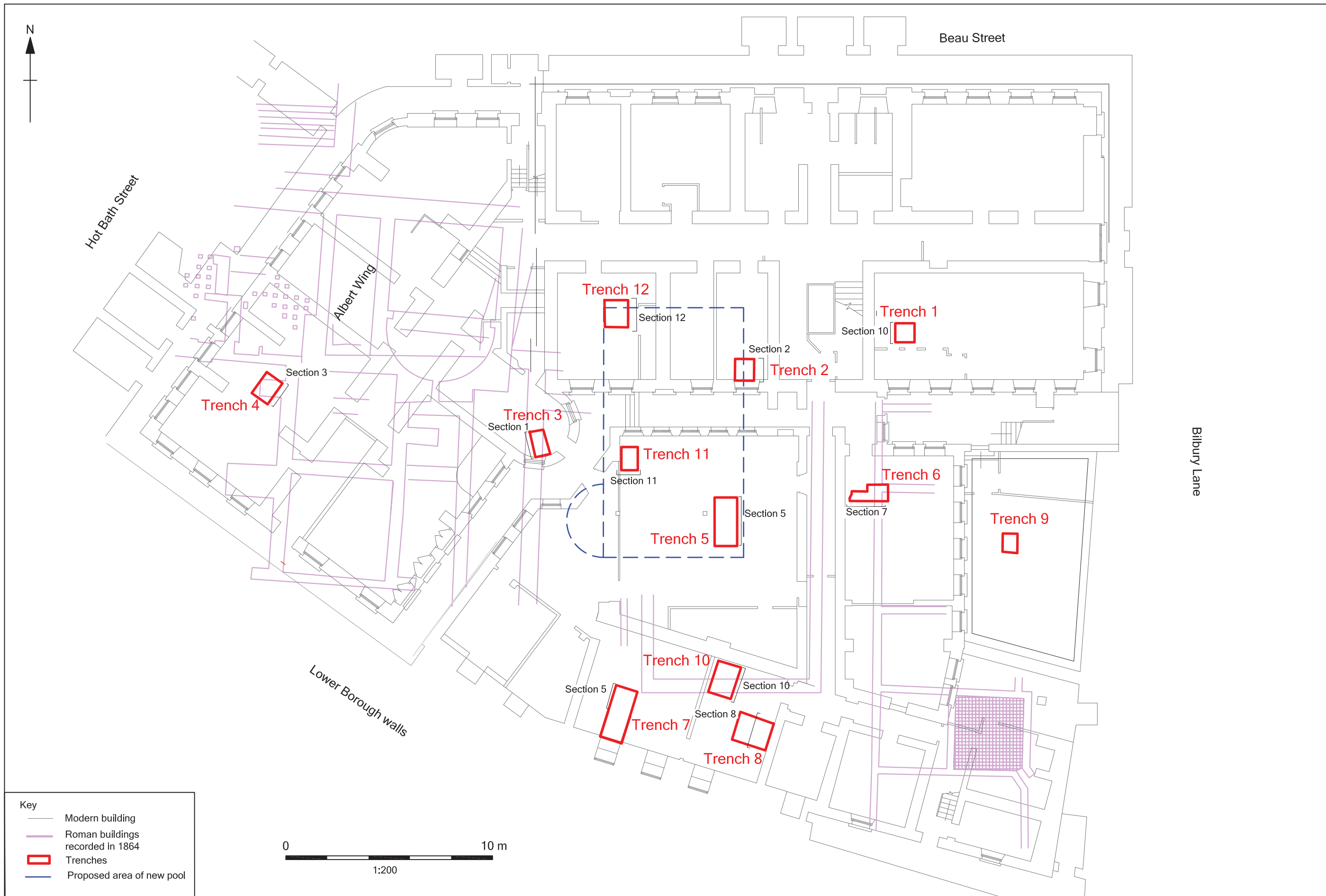

Figure 2: Trench location plan and previously recorded archaeological remains

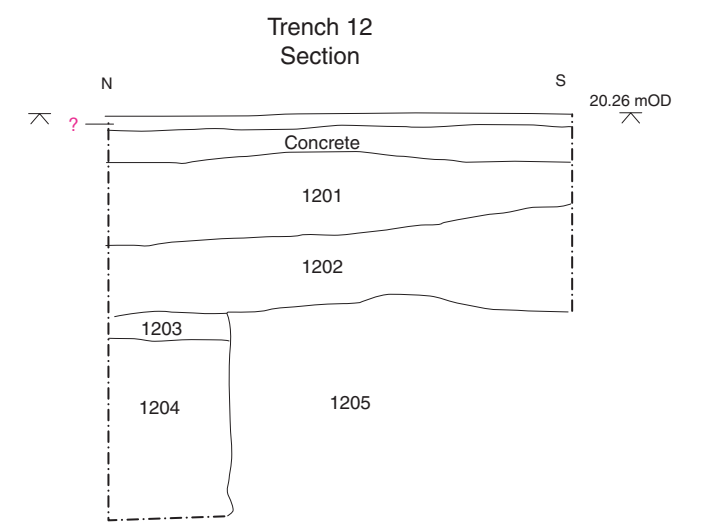
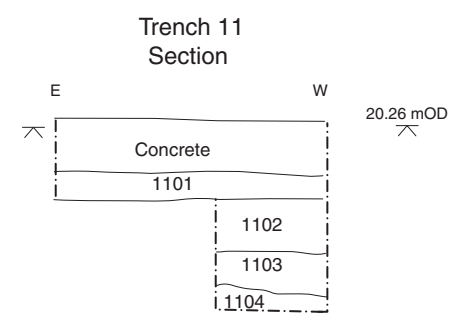
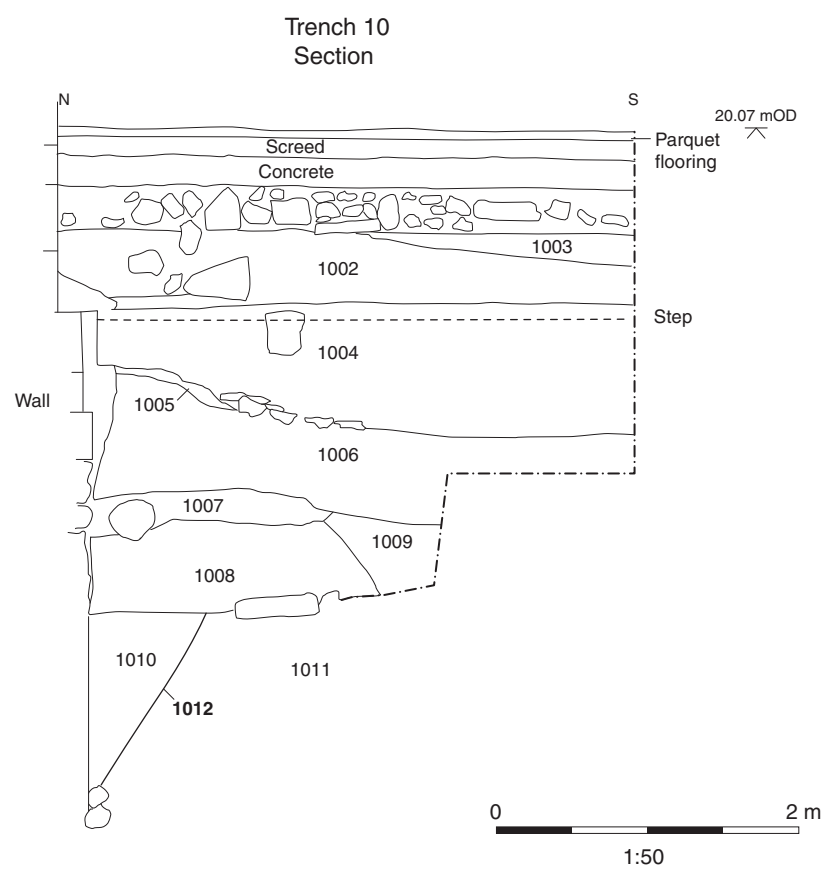
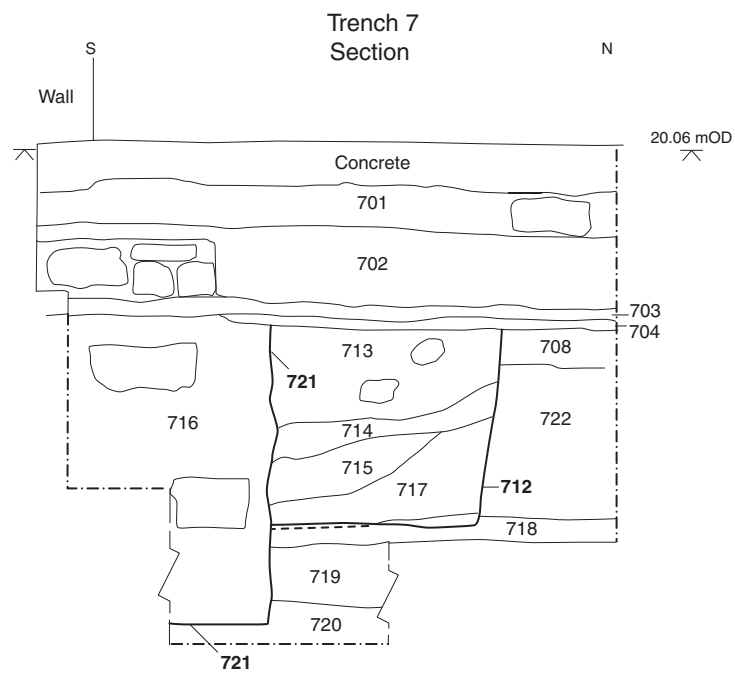
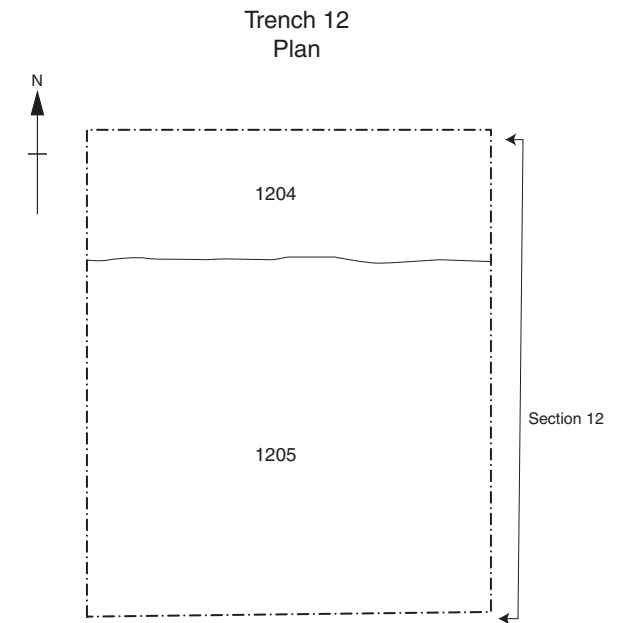
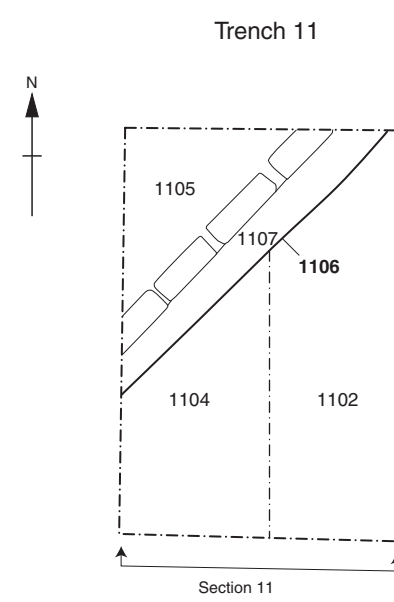
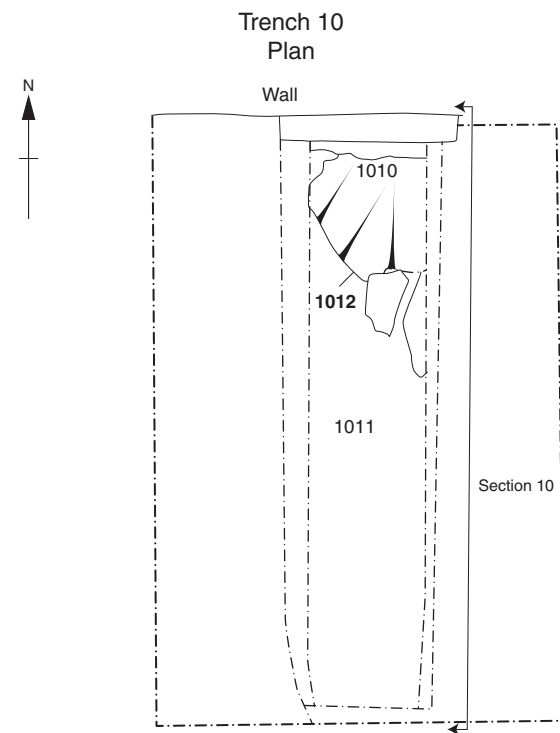
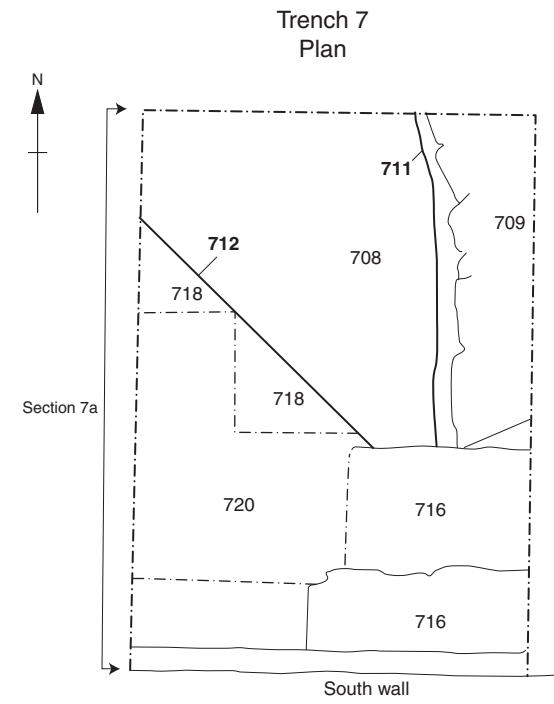

Figure 3: Trench plans 7, 10-12 and sections

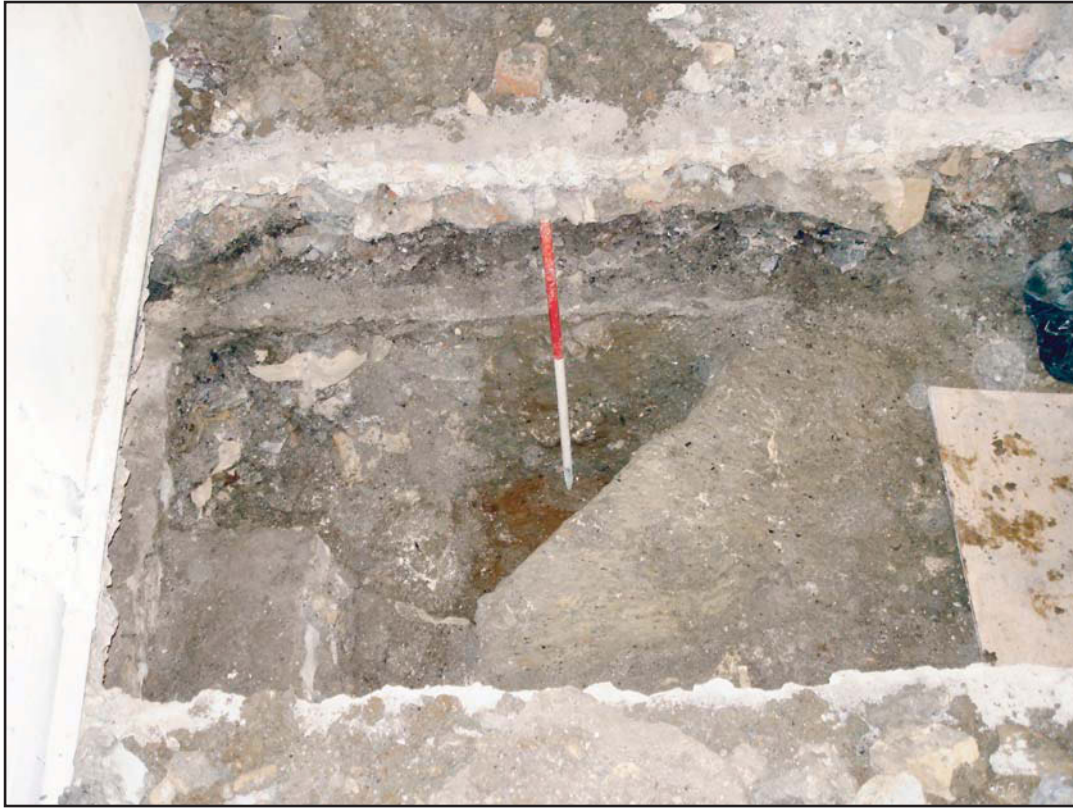

Plate 1: Trench 7 extension after excavation of 712 and partial removal of foundation 716, looking west



Plate 2: Trench 10, deep wall footings and adjacent deposits, looking north