

# Archaeology, Excavation & Surveys

**The Farmyard, Brickyard Lane  
Reed, Hertfordshire**

**Archaeological Investigations: Trenched Evaluation**



**Report No. AES/2015/14**

**The Farmyard, Brickyard Lane  
Reed, Hertfordshire**

**ARCHAEOLOGICAL INVESTIGATIONS:  
A TRENCHED EVALUATION**

Dawn Keen BA MA (Arch) PCIFA

**With Contributions by**

Paul Blinkhorn  
Tom Doig  
Robert Parker

November 2016

Site Code: **REEDBL15**  
NGR TL3608 3646  
Planning refs: 14/02573/1 & 15/01725/1  
Report No. AES/2015/14  
HER No: 196/16  
Event No: TBC  
Oasis id: archaeol15-209807

*Frontispiece: The pond on the old Brickworks*

© 2016. The material contained herein is and remains the sole property of Archaeology, Excavation & Surveys and is not for publication to third parties without prior consent. Whilst every effort has been made to provide detailed and accurate information, Archaeology, Excavation and Surveys cannot be held liable for errors or inaccuracies herein contained.

## **Non-technical Summary**

Archaeology, Excavation and Surveys completed an archaeological trenched evaluation between the 18<sup>th</sup> October 2016 to 21<sup>st</sup> October 2016 on approximately 0.66 hectares of former agricultural and industrial land on the edge of Reed village, in response to a planning requirement set by Andy Instone of Hertfordshire Environment Team prior to the development of the Proposed Development Area (PDA) with twelve dwellings, associated services and access (planning refs: 14/02573/1 & 15/01725/1).

Fifteen linear trenches totaling 150m in length, representing a 5% sample of the total Proposed Development Area (PDA), were opened using a 20 tonne 360 degree excavator with toothless ditching bucket under archaeological supervision.

The investigation primarily revealed the Proposed Development Area's (PDA) historic use for agriculture and industry, dating from the mid 19th century.

Modern overburden was found in all trenches representing the demolition of farm buildings prior to archaeological investigations (Waring, 2014).

Trenches 1, 4, 5, 9, 11, 14 and 15 contained layers of granulated chalk not found in trenches 2, 3, 6, 7, 8, 10, 12 and 13 possibly the hardstanding and access road to the Brickworks and Mill Corner Farm. A sandy layer was also present in trench 2, also possibly part of the latter.

Archaeological features revealed included 9 in 12 of the trenches opened. Two areas of archaeological significance were recorded (figure 2, Areas A and B).

Features in trenches 2, 4 and 6, revealed linears containing 19<sup>th</sup> century clay drains and in trenches 8, and 9 gravel drains. Features in trench 3 revealed a large area of brick rubble and brick dust relating to the sites use during the 19<sup>th</sup> century as a Brickworks. Trench 3 also contained four sherds of 19<sup>th</sup> century white earthenware tea-pot with a manganese glaze (Blinkhorn, 2016), brick fragments and a single light tan brick (Doig, 2016). Features in trench 13 revealed evidence of early 19<sup>th</sup> century Mill Corner Farm buildings in the form of brick footings and postholes, possibly relating to Mill Corner Farm. Trenches 10 and 12 revealed no features of archaeological activity.

Modern features were revealed in trenches 1, 7 and 15, two linears and a curvilinear which contained two drains, one made of plastic, the other in the form of bakelite, and an electric cable.

Ordnance survey (OS) maps from 1878 to 1911 show the presence of the brickworks, but which are no longer evident on the 1921 OS map. From the 1921 OS map, Mill Corner Farm is shown occupying the southern half of the PDA, however on the 1975 OS map only Farm buildings remain, Mill Corner Farm itself being relocated.

Although the site lies in close proximity to Roman Ermine Street, only a single rim sherd of Romano-British Grey Ware revealed evidence of Roman activity, found in Trench 12 (Blinkhorn, 2016). Additionally, metal detecting of spoil above trenches 3, 5 and 6 recovered an 18<sup>th</sup>-19<sup>th</sup> century livery button, 19<sup>th</sup> century machine plate and 18<sup>th</sup>-19<sup>th</sup> century thimble (Parker, 2016).

## CONTENTS

Non-technical summary	
1.0 Introduction	1
2.0 Compliance	1
3.0 Geology and Topography	1
4.0 Aims and objectives	2
5.0 Methodology	2
6.0 Archaeological and Historical Background	3
7.0 Archive	4
8.0 Results	4
8.1 Overview of results	
8.1.1 Trench 1	4
8.1.2 Trench 2	5
8.1.3 Trench 3	5
8.1.4 Trench 4	6
8.1.5 Trench 5	6
8.1.6 Trench 6	6
8.1.7 Trench 7	7
8.1.8 Trench 8	7
8.1.9 Trench 9	7
8.1.10 Trench 10	8
8.1.11 Trench 11	8
8.1.12 Trench 12	8
8.1.13 Trench 13	8
8.1.14 Trench 14	9
8.1.15 Trench 15	9
8.2 Metal detectorist survey	9
9.0 Conclusions	10
Acknowledgments	12
Bibliography	13

## SUPPORTING ILLUSTRATIONS

### APPENDICES

APPENDIX 1: Site location

APPENDIX 2: Site photographs

APPENDIX 3: Trench plans and sections

APPENDIX 4: Cartographic sources

APPENDIX 5: Archive qualification (Site Code: REEDBL15)

APPENDIX 6: Finds quantification

APPENDIX 7: Context summary

APPENDIX 8: Photographic Register

APPENDIX 9: SPECIALIST REPORTS

    Brickwork – Tom Doig

    Pottery - Paul Blinkhorn

APPENDIX 10: Metal detecting report

APPENDIX 11: Hertfordshire Historic Environment Record - Summary sheet

APPENDIX 12: Oasis Form

APPENDIX 13: Strip, Map and Record Report February 2017

### FIGURES

Figure 1: Site and trench location plans for The Farmyard, Brickyard Lane, Reed

Figure 2: Areas of archaeological significance Brickworks (A) and Mill Corner Farm (B)

Figure 3: Ordnance Survey map of 1878

Figure 4: Ordnance Survey map of 1898

Figure 5: Ordnance Survey map of 1911

Figure 6: Ordnance Survey map of 1921

Figure 7: Ordnance Survey map of 1975

Figure 8: South facing view of Trench 1

Figure 9: South facing view of Trench 2

Figure 10: South facing view of Trench 3

Figure 11: South facing view of Trench 4

Figure 12: South facing view of Trench 5

- Figure 13: South facing view of Trench 6
- Figure 14: South facing view of Trench 7
- Figure 15: South facing view of Trench 8
- Figure 16: South facing view of Trench 9
- Figure 17: South facing view of Trench 10
- Figure 18: South facing view of Trench 11
- Figure 19: South facing view of Trench 12
- Figure 20: South facing view of Trench 13
- Figure 21: North facing view of Trench 14
- Figure 22: North facing view of Trench 15
- Figure 23: Plan view of Trench 1
- Figure 24: Plan view of Trench 2
- Figure 25: Plan view of Trench 3
- Figure 26: Plan view of Trench 4
- Figure 27: Plan view of Trench 5
- Figure 28: Plan view of Trench 6
- Figure 29: Plan view of Trench 7
- Figure 30: Plan view of Trench 8
- Figure 31: Plan view of Trench 9
- Figure 32: Plan view of Trench 10
- Figure 33: Plan view of Trench 13
- Figure 34: Plan view of Trench 14
- Figure 35: Plan view of Trench 15
- Figure 36: East facing section no 3 of Trench 3, Area A
- Figure 37: East facing section no 9 of Trench 13, Area B
- Figure 38: West South West facing section through linear [31]
- Figure 39: North West facing section through posthole [38]
- Figure 40: West North West facing section through posthole [47]

## 1.0 Introduction

An archaeological evaluation was carried out at The farmyard, Brickyard Lane, Reed, by Archaeology, Excavation and Surveys (AES) from 18<sup>th</sup> October 2016 to 21<sup>st</sup> October 2016 inclusive, commissioned by Mr Iain and Mrs Cleo Ford, of Ford Homes.

The village of Reed is located in the county of Hertfordshire. The site comprises an area of c.0.66ha, bounded to the east by Brick Yard Lane, with agricultural land to the north and west of the site. The site housed part of Mill Corner Farm, which comprised of a number of 20th century timber-framed buildings, built over the site of a 19th century brickyard (Waring 2014).

The proposed development consists of 6 detached 4-bed dwellings (plots 1-4, 8 and 9), 2 semi-detached 3-bed dwellings (plots 5 and 6), one detached 3-bed dwelling (plot 7) and a terrace of 3 x 2-bed dwellings (lots 10-12) together with associated car ports, parking and landscaping with access from Brickyard Lane. The site is centred on national grid reference NGR TL3608 3646 (planning ref: 14/02573/1 & 1/01725/15).

A 5% sample of the site, consisting of fifteen 10m by 2.0m trenches, was excavated by 20 tonne tracked excavator with toothless ditching bucket. This work followed the Written Scheme of Investigation produced by Archaeology, Excavation and Surveys (April 2015) and approved by Andy Instone Senior Archaeologist, Historic Environment Team (HET) Hertfordshire County Council.

The proposed development lies on land with potential for archaeological remains and the Local Planning Authority (LPA) has been advised that any planning consent should be conditional upon an agreed programme of archaeological investigation before any development takes place.

## 2.0 Compliance

When completing the work, Archaeology, Excavation and Surveys will adhere to the requirements established by HCC HEU, and the Chartered Institute of Field Archaeologists (CIFA). Standards and guidelines as stated within the following documents: *North Hertfordshire District Council Local Plan 1996, policy 16 and draft 2011-2031* and the national policies contained in the *National Planning Policy Framework (March 2012)* and *Standard and Guidance for an Archaeological Field Evaluation*, (CIFA, updated Nov 2013).

## 3.0 Geology and Topography

The Farmyard, Brickyard Lane is situated on a plateau of land at c.150m AOD. A steep escarpment is found immediately north of the village of Reed, sloping downwards to the north and marking the extent of the chalk upland that forms the Chilterns to the south west. The soils are of Hanslope formation, which predominantly comprises slowly permeable calcareous clayey soils. These overlie quaternary drift geology of Lowestoft Till: a bluish grey, sandy silty clay derived largely from Jurassic clays with erratics of mainly chalk and flint. The solid geology of the area is upper clay (Waring, 2014).

#### 4.0 Aims and objectives

The aims of the evaluation were as follows:

- to enable the archaeological resource, both in quantity and extent, to be accurately quantified.
- to identify the date, approximate form and purpose of any archaeological deposits, together with its likely extent, localized depth and quality of preservation.
- to identify the potential for environmental deposits.
- to further elaborate on the nature, period and morphology of the cropmarks.
- to further elaborate on the agricultural and industrial development of the village of Reed.
- to enhance the understanding of the village of Reed through the examination of the date, form and character within its local, regional and national context.
- to produce a permanent record of the site in an archive that will be deposited with Hertfordshire County Council (HCC HEU).
- the site will be recorded under a new site code (REEDBL15). A copy of the report will be deposited on to OASIS under the reference of archaeol15-209807 upon the completion of the work.

The aims were to be achieved using a combination of methodologies of a linear trenched evaluation and analysis of cartographic and historical sources. This report details the results of the investigation together with an assessment of the archaeological evidence discovered.

#### 5.0 Methodology

The evaluation trenching represented a 5% sample of 0.66ha of a former agricultural and industrial zone. This equated to 300sqm of linear trenching with each trench measuring 10m x 2.0m. Trench 13 was to be positioned at the southern end of the development area, but was repositioned due to an area of Japanese Knotweed contamination.

Machining was carried out under constant archaeological supervision using a 20 tonne tracked 360° excavator with a 1.8m wide toothless ditching bucket.

The trenches were tied into the National Grid using a Leica 1200 GPS Smart Rover with RTK differential correction giving global positioning accuracy to within 2cm.

Spoil, exposed surfaces and features were scanned with a metal detector and hand collected finds were retained for inspection, other than those, which were obviously modern.

All archaeological features, deposits and layers were recorded using AES *pro forma* context sheets. Features are denoted for the purposes of this project with the prefix F and are numbered alongside layer, cut and fill numbers. Trench locations, plans

and sections were recorded at appropriate scales and site photographs were taken of all trenches, profiles and any features using a Canon EOS 1100 SLR digital camera.

The work was completed in varied conditions from good, sunny and dry to heavy showers and wet.

Prior to the fieldwork an HER code (196/16) was obtained from the HHET. This number was clearly marked on any documentation relating to the work and in any reports arising from the work.

## **6.0 Archaeological and historical background**

The development site lies on the edge of the village of Reed. The following provides a brief overview of the archaeological and historical background to the proposed development site (Keen, 2015). A more extensive survey of the archaeology and history of the area is available within the desk-based assessment written by Waring (2014) on the Farmyard, Brickyard Lane.

### Prehistory (500,000 BC to 43 AD)

Known cropmarks within the area surrounding the site are attributed to prehistoric features including Neolithic ring ditches and round barrows, as well as a Bronze Age enclosure and bell barrow, and early Neolithic – late Bronze Age cemetery on the south western edge of Royston. In addition to this, find spots have yielded Bronze Age and Iron Age pottery. The site is situated 5km south of the Icknield Way, an ancient trackway, flanked along the extent of its route by prehistoric features; thus placing Reed within a significant prehistoric landscape.

### Roman (AD 43- 410)

Scattered findspots in the form of Roman coins (HER 1522), bronze figure of Mars and silver votive tablets (HER nos 490, 2233), attest to the Roman period in Reed, likely as a result of the close proximity of Roman Ermine Street less than 300m to the west.

### Anglo-saxon (AD 410-1066)

There is little evidence for Anglo-Saxon activity within the area of the site, apart from a late Saxon parish church (HER 4035).

### Medieval (1066-1540)

Archaeological evidence for the medieval period within and surrounding Reed village is extensive, being mentioned in the Domesday Book as Retth or Rete (HER 2702) and existing in the form of homestead moats (HER 1922, 4026, 9099), manor (HER 15908), a possible motte and bailey castle at Periwinkle Hill (HER 855) and evidence of agricultural practice in the form of ridge and furrow and earthworks on the edge of the village (HER nos; 7776, 7783, 77787, 11427, 18178).

### Post-medieval (1539-1900)

Post-medieval features known within the immediate vicinity of the site, include two large farmsteads, one at Queenbury and the other at Wisbridge Farm (HER nos 11038, 11039).



Occupation on the site appears to commence during the post-medieval period with the mention of a thatched cottage, brick built kiln and kiln pit in details of a sale of the land in 1898 (Waring, 2014), and also the emergence of the brickyard and associated structures, which appear on maps until 1921, when it became part of Mill Corner Farm, the farmyard and agricultural buildings still in part remaining.

## 7.0 Archive

A total of 64 contexts were excavated and recorded, and artefacts including: pottery; fe nails and ceramic building material were recovered and catalogued. All documentary records and accompanying artefacts have been assembled into a catalogued archive in line with MoRPHE (2015) and are currently being stored at the AES offices, until deposition with Hertfordshire Museums Service.

## 8.0 Results

### Overview of results

The results of the evaluation are presented sequentially by trench. A full context list can be found in Appendix 7. The site makeup was found to consist of a leveling layer of c.1 - 1.5m in depth consisting of building demolition materials, sealing the preserved archaeology. As the leveling or demolition layers varied little in composition across the proposed development (PDA), it will therefore only be described once. Trenches 1, 4, 5, 9, 11, 14 and 15 contained layers of granulated chalk not found in trenches 2, 3, 6, 7, 8, 10, 12 and 13. A sandy layer c0.40m in depth was also present in trench 2.

Archaeological features were found in 12 of the trenches opened, within which, were two areas of potential archaeological significance (Figure 2; Areas A & B). Evidence of 19th century drainage was found in trenches 2, 4, 6, 8 and 9. Trench 3 revealed 19th century features in the form of brick remnants relating to the Brickworks after which Brickyard Lane was named. Trenches 13 and 14 revealed early 20th century features in the form of postholes and building remains relating to Mill Corner Farm buildings. Trenches 10 and 12 revealed no archaeological features.

Modern features revealed included evidence for 20th century drainage in trenches 1 and 7, and services in trench 15, relating to the sites history for agricultural use.

### Results

**8.1.1 Trench 1** was located towards the northern boundary of the site, at right angles to Brickyard Lane and the site entrance, orientated north/south (figures 1, 2, 8 and 23). The trench measured  $\leq 10\text{m}$  in length and  $\leq 2.0\text{m}$  in width and was machined to a depth of  $\leq 0.45\text{m}$  where natural clays were encountered. Demolition layer (1) extended beyond the trench boundaries and measured  $\leq 0.05\text{m}$  -  $\leq 0.20\text{m}$  in depth, it overlay clay silt layer (2).

Layer (2) consisted of a light to med grey brown clay silt with inclusions of granulated chalk and occasional brick and flint inclusions  $\leq 0.05\text{m}$  -  $\leq 0.10\text{m}$  and measured  $\leq 7.75\text{m}$  length x  $\leq 2\text{m}$  width x  $\leq 0.05\text{m}$  -  $\leq 0.25\text{m}$  depth, which lay beneath demolition layer (1) and overlay natural clays. The layer (2) extended beyond the trench boundaries, it was cut by drain cut [3].

The trench contained one feature:

The feature, a 20<sup>th</sup> century plastic drain F(4), was located towards the southern end of the trench, linear in plan and orientated East/West. The cut [3] measured  $\leq 2.0\text{m}$  length x  $\leq 0.60\text{m}$  width x  $\leq 0.25\text{m}$  depth and was filled by a loose light to mid grey brown sandy silt (5).

**8.1.2 Trench 2** was located towards the northern boundary of the site, at right angles to Brickyard Lane and the site entrance, and orientated north/south (figures 1, 2, 9 and 23) The trench measured  $\leq 10\text{m}$  in length and  $\leq 2.0\text{m}$  in width and was machined to a depth of  $\leq 0.55\text{m}$ , where natural clays were encountered.

The demolition layer (1) measured  $\leq 0.05\text{m}$  to  $\leq 0.35\text{m}$  in depth extending the length and width of the trench, it overlay field drain F(9), a sandy silt layer (7)  $\leq 5.25\text{m}$  width x  $\leq 0.25\text{m}$  depth at the southern end of the trench and natural clay (6) at the north,  $\leq 4.15\text{m}$  width and  $\leq 0.45\text{m}$  depth.

The trench contained one feature.

The feature consisted of a clay 19<sup>th</sup> century drain F(9) found at the northern end of the trench, linear in plan and orientated East/West and lay within cut [8]. It was made of clay with a diameter of  $\leq 0.20\text{m}$ , the cut of the drain [8] measured  $\leq 2.0\text{m}$  length x  $\leq 0.50\text{m}$  width x  $\leq 0.25\text{m}$  depth and was filled by a loose light to mid grey brown sandy silt clay (10). The drain cut [8], cut into natural clays (6) and was overlain by demolition layer (1).

**8.1.3 Trench 3** was located towards the northern boundary of the site at right angles to Brickyard Lane and orientated north/south (figures 1, 2, 10 and 25). The trench measured  $\leq 10\text{m}$  in length and  $\leq 2.0\text{m}$  in width and was machined to a depth of  $\leq 0.40\text{m}$  where the natural clays (6) were encountered. The demolition layer (1) was  $\leq 0.05\text{m}$  –  $\leq 0.10\text{m}$  in depth.

The trench contained one feature.

The feature F(68) consisted of brick remnants possibly from the 19<sup>th</sup> century brickworks (figure 35, Doig 2016), roughly rectangular in plan, the extent of which was  $\leq 6\text{m}$  length x  $\leq 1.26\text{m}$  –  $\leq 1.75\text{m}$  width x  $\leq 0.35\text{m}$  depth extending beneath the western and southern trench edges. An investigation slot [31] was dug measuring  $1\text{m}$  in width x  $1\text{m}$  in length x  $\leq 0.45\text{m}$  in depth, with sloping sides and concave base, it filled by a single fill (32) consisting of a solid compact terracotta red brick dust, brick fragments and heated clay (figure 36).

Four sherds of a 19<sup>th</sup> century white earthenware tea-pot with a manganese glaze were uncovered within fill (32). (Blinkhorn, 2016).

Brickwork remnants from Trench 3 were analysed by Mr T Doig (see appendix 10) the sample analysed included brick fragments which measured approx.  $9.125''$  x  $2.125''$  x  $4.5''$ , dated to the mid c1800s and a light tan coloured whole brick recovered from fill (32).

The brick fragments were of high quality, well-fired and of moderately well-puddled clay local to Reed, with white chalk or shell inclusions and handmade in wooden moulds with a shallow frog insertion, The upper face of the bricks was cut used a flat-bladed strike, which occasionally caught on protruding inclusions. Some samples showed sagging in the centre of the long face. A possible pantile was also included within the sample of brick fragments.

Light tan brick was also included within the brick fragment sample (32) in investigation slot [31], this measured 9" x 4.5" x 1.75". It was hand made from a wooden mould, with good quality puddling and fewer large inclusions. It shows strike marks just prior to it being released from the mould. This example was stacked in the drying shed on its edge and one long, side face shows the impression of another damp brick being placed above it. The brick was fired in a kiln and was given slightly less than the optimum length of time (or possibly the kiln did not reach its full temperature) as the inner core of the brick does not show the rich tan colour of the 'skin'. Other evidence of the rather under-firing are the minor cracks on the upper face where the brick had sagged in the kiln. It is possibly manufactured at Reed, but could have been imported (Doig, 2016)

**8.1.4 Trench 4** was located on the northern boundary of the site, at right angles to Brickyard Lane and orientated north/south (figures 1, 2, 11, and 26). The trench measured  $\leq 10\text{m}$  in length and 2.0m in width and was machined to a depth of  $\leq 0.50\text{m}$  where the natural clays (6) were encountered at the northern end. The demolition layer (1) was  $\leq 0.20\text{m}$  to  $\leq 0.48\text{m}$  in depth and overlay natural clays (6) and chalk layer (16).

Layer (16) consisted of solid compacted granulated chalk with frequent inclusions in the form of nodular flint a compact off-white granulated chalk with occasional nodular flint inclusions  $\leq 0.10\text{m}$  -  $\leq 0.20\text{m}$  and measured  $\leq 5.4\text{m}$  length x  $\leq 2\text{m}$  width x  $\leq 0.05\text{m}$  -  $\leq 0.25\text{m}$  depth, lies beneath demolition layer (1) and overlies natural clays. The layer (16) extended beyond the trench boundaries towards the southern end of the trench, possibly forming the hardcore of a roadway for the 19<sup>th</sup> century Brickworks (figure 1). The layer (16) was cut by drain cut [13].

The trench contained one feature.

The feature consisted of a clay field drain F(14) located towards the northern end of the trench, linear in plan and orientated East/West, possibly of 19<sup>th</sup> century date. The drain F(14) was  $\leq 0.30\text{m}$  in diameter and cut into the natural clay (6). The drain cut [13] was  $\leq 0.50\text{m}$  to  $\leq 0.90\text{m}$  in width, and filled with a compact light orangey grey brown sandy silty clay (15).

**8.1.5 Trench 5** was located on the northern boundary of the site, at right angles to Brickyard Lane to the east and orientated approximately north/south (figures 1, 2, 12, and 27). The trench measured  $\leq 10\text{m}$  in length and  $\leq 2.0\text{m}$  in width and was machined to a depth of  $\leq 0.20\text{m}$  where the natural clays were encountered. The demolition layer (1) was  $\leq 0.10\text{m}$  -  $\leq 0.55\text{m}$  in depth and overlay chalk layer (18)

Layer (18) consisted of a fairly compact off-white chalk lump with occasional flint inclusions  $\leq 0.05$  -  $\leq 0.10\text{m}$ , which measured  $\leq 4\text{m}$  length x  $\leq 2\text{m}$  width x  $\leq 0.35\text{m}$  depth and located at the southern end of the trench it extended beyond the boundaries both to the south, west and east, possibly forming the hardcore of a roadway for the 19<sup>th</sup> century Brickworks, cut into the natural clay (6).

No archaeological finds or features were recovered.

**8.1.6 Trench 6** was located on the western boundary of the site, parallel to Brickyard Lane to the east and orientated approximately north/south (figures 1, 2 13, and 28). The trench measured  $\leq 10\text{m}$  in length and 2.0m in width and was machined to a depth of  $\leq 0.60\text{m}$  where the natural clays were encountered. The demolition layer

(1) was  $\leq 0.05\text{m}$  -  $\leq 0.15\text{m}$  in depth and overlay the natural clays (6) and field drain F(20).

The trench contained one feature.

The feature consisted of a clay field drain F(20) located towards the northern end of the trench, linear in plan, orientated North East/South West, possibly of 19<sup>th</sup> century date. The drain F(20) was  $\leq 0.30\text{m}$  in diameter and cut into the natural clay (6). The drain cut [19] was  $\leq 2\text{m}$  length x  $\leq 0.50\text{m}$  width x  $\leq 0.10\text{m}$  depth, and filled with a compact light – mid grey brown clay silt (21) measuring  $\leq 0.10\text{m}$  either side of the drain F(20).

**8.1.7 Trench 7** was located on the eastern boundary of the site, parallel to Dreadnought Villa (figure 7) and at right angles to Brickyard Lane to the east, orientated north/south (figures 1, 2, 14, and 29). The trench measured  $\leq 10\text{m}$  in length and  $\leq 2.0\text{m}$  in width and was machined to a depth of  $\leq 0.60\text{m}$  where the natural clays (6) were encountered. The demolition layer (1) was  $\leq 0.10\text{m}$  -  $\leq 0.45\text{m}$  in depth.

The trench contained one feature.

The feature consisted of a bakelite field drain F(23), located towards the middle of the trench, linear in plan, orientated East/West, and dating to the 20<sup>th</sup> century (bakelite patented 1907). The drain F(23) was  $\leq 0.20\text{m}$  in diameter and cut into the natural clay (6). The drain cut [22] was  $\leq 2.0\text{m}$  in length x  $\leq 0.40\text{m}$  in width and filled with a compact light mid grey brown chalky clay silt (24).

**8.1.8 Trench 8** was located on the western boundary of the site, parallel to Brickyard Lane to the east and orientated approximately north/south (figures 1, 2, 8 and 29). The trench measured  $\leq 10\text{m}$  in length and  $\leq 2.0\text{m}$  in width and was machined to a depth of  $\leq 0.40\text{m}$  where the natural clays (6) were encountered, depth in section  $\leq 0.20\text{m}$ . The demolition layer (1) was  $\leq 0.05\text{m}$  -  $\leq 0.25\text{m}$  in depth.

The trench contained one feature.

The feature consisted of a field drain F(26), made up solely of gravel, located towards the northern end of the trench. It was linear in plan, orientated North North East/South South West, and possibly dating to the 19<sup>th</sup> century. The drain cut [25] was cut into the natural clay (6). The drain cut [25] was  $\leq 5.0\text{m}$  in length x  $\leq 0.15\text{m}$  in width and filled with subangular stones and pebbles, no pipe was present.

**8.1.9 Trench 9** was located on the western boundary of the site, parallel to Brickyard Lane to the east and orientated approximately north/south (figures 1, 2, 16 and 31). The trench measured  $\leq 10\text{m}$  in length and  $\leq 2.0\text{m}$  in width and was machined to a depth of  $\leq 0.55\text{m}$  where the natural clays were encountered. The demolition layer (1) was  $\leq 0.20\text{m}$  to  $\leq 0.45\text{m}$  in depth.

Layer (27) consisted of a compact off-white granulated chalk with occasional nodular flint inclusions  $\leq 0.10\text{m}$  -  $\leq 0.20\text{m}$  and measured  $\leq 5.0\text{m}$  length x  $\leq 0.90\text{m}$  width x  $\leq 0.22\text{m}$  in depth within which gravel field drain F(29) was cut [28]. The layer extended beneath the southern and eastern edges of the trench.

The trench contained one feature.

The feature consisted of a field drain F(29) made up solely of gravel, linear in plan and orientated North East/South West and possibly dated to the 19<sup>th</sup> century. It

measured  $\leq 6.75\text{m}$  length x  $\leq 0.10 - \leq 0.12\text{m}$  width x  $\leq 0.20\text{m}$  depth, sealed with compact mid orangey brown silt clay (30) [28], and cut into chalk layer (27) and natural clay (6).

**8.1.10 Trench 10** was located on the western boundary of the site, parallel to Brickyard Lane to the east and orientated approximately north/south (figures 1, 2 and 17). The trench measured  $\leq 10\text{m}$  in length and  $\leq 2.0\text{m}$  in width and was machined to a depth of  $\leq 0.45\text{m}$  where the natural clays were encountered. The demolition layer (1) was  $\leq 0.10\text{m} - \leq 0.25\text{m}$  in depth.

No archaeological finds or features were recovered.

**8.1.11 Trench 11** was located on the southern half of the site, equi-distant between eastern and western site boundaries, and orientated approximately north/south (figures 1, 2 and 18). The trench measured  $\leq 10\text{m}$  in length and  $\leq 2.0\text{m}$  in width and was machined to a depth of  $\leq 0.45\text{m}$  where the natural clays were encountered. The demolition layer (1) was  $\leq 0.10\text{m} - \leq 0.20\text{m}$  in depth.

Layer (62) consisted of a compact off-white granulated chalk with occasional nodular flint inclusions  $\leq 0.10\text{m} - \leq 0.20\text{m}$ , which measured  $\leq 0.30\text{m}$  length x  $\leq 2.0\text{m}$  width x  $\leq 0.10\text{m}$  in depth and was located at the northern end of the trench.

No archaeological finds or features were recovered.

**8.1.12 Trench 12** was located on the eastern boundary of the site, parallel to the boundary of Gladstone Villas and Brickyard Lane to the east and orientated approximately north/south (figures 1, 2, 7 and 19). The trench measured  $\leq 10\text{m}$  in length and  $\leq 2.0\text{m}$  in width and was machined to a depth of  $\leq 0.45\text{m}$  where the natural clays were encountered. The demolition layer (01) was  $\leq 0.10\text{m} - \leq 0.25\text{m}$  in depth.

A single rimsherd from a Romano-British sandy grey ware jar was recovered during machining of the trench (Blinkhorn, 2016).

**8.1.13 Trench 13** was located towards the southern boundary of the site, directly east of Trench 10 parallel to Brickyard Lane and orientated approximately north/south (figures 1, 2, 20, and 33). The trench measured  $\leq 10\text{m}$  in length and  $\leq 2.0\text{m}$  in width and was machined to a depth of  $\leq 0.45\text{m}$  where the natural clays (6) were encountered. The demolition layer (1) was  $\leq 0.10$  to  $\leq 0.20\text{m}$  in depth, which overlay masonry layer 1, this in turn overlay the natural clays (6).

The trench contained three features.

The first feature F(65) the footings of a brick building, were revealed on the western and southern side of the trench, being tied in at the south-eastern corner, located under the baulk edge. The brick footings consisted of red handmade bricks with a shallow frog, which measured  $\leq 0.20\text{m} \times \leq 0.11\text{m} \times \leq 0.07\text{m}$ . The total footings revealed in section, measured  $\leq 11.5\text{m}$  in length and  $\leq 2\text{m}$  wide extending beneath the western side of the trench.

The second feature F(66) recovered was a group of postholes [33], [36], [38], [42], [45] and [48] circular in form, linear in formation and orientated North/South, of which only [38] was excavated and measured  $\leq 0.40\text{m}$  in diameter and  $\leq 0.15\text{m}$  in depth (figure 37). Posthole fill (40) consisted of a compact light grey brown clay silt, with frequent chalk lumps and wood fragments, occasional residual brick fragments and small flints ( $\leq 0.01\text{m} - \leq 0.02\text{m}$ ). The profile of posthole [38] is steeply sloping to near

vertical sides with a relatively flat base. The post remnants (39) were wooden and had been burnt and measured  $\leq 0.14\text{m}$  in length x  $\leq 0.14\text{m}$  in width x  $\leq 0.15\text{m}$  in depth. The posts were cut into the natural clays (6).

Five iron (Fe) post nails were found in situ (39) [38].

The third feature F(67) recovered, included smaller postholes, both circular and square; two postholes [50] and [52] circular in form, stood side by side, orientated East/West and measured  $\leq 0.35\text{m}$  in diameter and  $\leq 0.27\text{m}$  in depth. Postholes [47], [54] and [56] are square in form, of which only [47] was excavated and measured  $\leq 0.35\text{m}$  in diameter and  $\leq 0.27\text{m}$  in depth (figure 38). Postholes [47], [54] and [56] were linear in formation and orientated North/South. The posthole fill (49) consists of a compact light grey brown clay silt, with chalk and chalk lump inclusions, few residual brick fragments, occasional small flints and wood fragments which measured  $\leq 0.01\text{m}$  –  $\leq 0.02\text{m}$ . The profile of posthole [47] is steeply sloping to near vertical sides with a V-shaped base. The post remnants (48) measured  $\leq 0.09\text{m}$  in length x  $\leq 0.09\text{m}$  in width x  $\leq 0.15\text{m}$  in depth, of which some burning was evident. The posts were cut into the natural clays (6).

**8.1.14 Trench 14** was located on the southern boundary of the site, parallel to Trench 15 to the east and orientated approximately north/south (figures 1, 2, 21 and 34). The trench measured  $\leq 10\text{m}$  in length and  $\leq 2.0\text{m}$  in width and was machined to a depth of  $\leq 0.40\text{m}$  where the natural clays (6) were encountered. The demolition layer (1) was  $\leq 0.10\text{m}$  to  $\leq 0.30\text{m}$  in depth.

Layer (63) consisted of a compact off-white granulated chalk with occasional nodular flint inclusions  $\leq 0.05\text{m}$  -  $\leq 0.20\text{m}$  and measured  $\leq 2.5\text{m}$  in length and  $\leq 0.10\text{m}$  in depth, was overlain by demolition layer (1), it extended beneath the eastern edge of the trench.

Layer (58) consisted of brick rubble and measured  $\leq 1.85\text{m}$  length x  $\leq 0.90\text{m}$  width this was located on the western side of the trench and overlay the natural clays (6).

No archaeological finds or features were recovered.

**8.1.15 Trench 15** was located on the southern boundary of the site, at right angles to a residential boundary and Brickyard Lane to the east, and orientated approximately north/south (figures 1, 2, 22 and 35). The trench measured  $\leq 10\text{m}$  in length and  $\leq 2.0\text{m}$  in width and was machined to a depth of  $\leq 0.60\text{m}$  where the natural clays (6) were encountered. The demolition layer (1) was  $\leq 0.10\text{m}$  -  $0.30\text{m}$  in depth.

Layer (64) consisted of a compact off-white granulated chalk with occasional nodular flint inclusions  $\leq 0.10\text{m}$  -  $\leq 0.20\text{m}$  and measured  $\leq 4.0\text{m}$  in length and  $\leq 0.20\text{m}$  in depth in the western section of the trench. It was overlain by demolition layer (1) and extended beneath the northern edge of the trench.

The trench contained one feature.

A curvilinear feature F[59], located at the northern end of the trench, measured  $\leq 0.30\text{m}$  –  $\leq 0.40\text{m}$  in width x  $\leq 2.85\text{m}$  in length. It extended beneath both north-eastern and western trench edges, it was filled by a loose chalk lump deposit (61) and found to contain an electric cable (60).

## **8.2 Metal Detectorist Survey**

Excavated trench bases, features and spoil heaps were scanned by an experienced metal detectorist, see overview of finds (Appendix 10).

## 9.0 Conclusions

In conclusion the evaluation achieved the aims and objectives as required by Hertfordshire Historic Environment Team.

The evaluation was appropriate to the nature of the development. Weather conditions were generally favourable, but with occasional episodes of inclement weather.

The archaeological resource in quantity and extent was quantified through detailed recording of the finds and features in all fifteen trenches sampling the 0.66ha area of the PDA. From the information recovered it was possible to date, identify and define the purpose of the archaeology deposits found through historic documentation and specialist knowledge, together with its likely extent, localized depth and quality of preservation.

The results of the investigation revealed archaeological remains of some value and significance present on the site, dating from the mid 19th century to early 20th century. These were in two areas A and B concentrated in trenches 1, 2, 3, 4 and 6 (figures 5 to 7) and represent a 19th century Brickworks as documented on the Ordnance Survey map of 1878 and also 20<sup>th</sup> century Mill Corner Farm in area B as referenced on the Ordnance Survey map of 1911.

Trenches 1, 4, 5, 9, 11, 14 and 15 contained layers of granulated chalk not found in trenches 2, 3, 6, 7, 8, 10, 12 and 13. A sandy layer was also present in trench 2. It is possible that the layers formed part of hardstanding and roadways linked to the Brickworks and Mill Corner Farm. Evidence of drainage was found in trenches 2, 4, 6, 8 and 9 possibly dating to the 19<sup>th</sup> century. Trench 3 revealed 19th century features in the form of brick remnants relating to the Brickworks after which Brickyard Lane was named. Trenches 13 and 14 15 revealed early 20th century features in the form of postholes and building footings relating to Mill Corner Farm buildings. Trenches 10 and 12 revealed no archaeological features. Modern features revealed included evidence for 20th century drainage in trenches 1 and 7 and a service cable in trench 15, relating to the sites history for agricultural use.

From the archaeology discovered on the PDA, it has also been possible to further elaborate on the industrial and agricultural development of the village of Reed. A contribution has been made to the industrial development of the site with the discovery of the remains of the Brickworks, and evidence of drainage. The remnants discovered in trench 3, also provide further evidence for the development of Reed as a village and potentially reflecting an increase in population at that time with the need for bricks. From 1911 onwards (figure 5) farm buildings on the PDA increase as noted with the comparison of the Ordnance Survey maps of 1878 and 1898. By 1975 (figure 7 OS map) the brickworks drying sheds have been demolished, reflecting a transition from brickmaking to agriculture. A further understanding of the development of the village of Reed, has therefore been gained from both documentary and archaeological evidence for the existence and extent of the Brickworks and Mill Corner Farm.

Overall, the PDA has evidence for use and activity from the late 19th century in the form of the Brickworks and from early 20th century with the introduction of buildings belonging to Mill Corner Farm. The potential for further remnants of the Brickworks to remain is high and possibly lie beneath the late 20<sup>th</sup> century Farm building remnants, demolition layer and remaining topsoil, and similarly with that of Mill Corner Farm.

Negative evidence for Bronze age and Iron Age activity was recovered (Waring 2014) and little evidence for Roman activity in the form of a single rim sherd of Romano-British sandy grey ware was recovered in trench 12. Three metal finds in the form of a livery button, machine plate and thimble dating to the 18<sup>th</sup> to 19<sup>th</sup> century further confirmed post medieval activity on the PDA (Parker, 2016).



## **Acknowledgements**

Archaeology, Excavation & Surveys would like to thank Mr & Mrs Ford of Ford Homes for commissioning the archaeological investigation. Thanks also to Andy Instone, Historic Environment Officer of the Historic Environment Team, Hertfordshire County Council in providing the initial Project Brief and for commenting on the Written Scheme of Investigation and final report.

Thanks to Robert Parker for his help on site completing the metal detecting survey and Matthew Jones of Pre-Construct Archaeology (Central) for assisting with surveying.

The site work was directed by Dawn Keen BA MA PCIFA and assisted by Caroline Sims BSc MSc PCIFA, Maria Buczak MA and Lucy Van de Wijk.

## Bibliography

Brown N., & Glazebrook J., (eds.), 2000, *Research and Archaeology: A Framework for the Eastern Counties*, East Anglian Archaeology Occasional Papers 8

CIFA (2014), *Standard and guidance for archaeological field evaluation*.

CIFA (2014), *Standard and guidance for the creation, compilation, transfer and deposition of archaeological archives*.

English Heritage (reissue 2015), *Management of Archaeological Projects in the Historic Environment* (MoRPHE).

Glazebrook J., (ed.) 1997 *Research and Archaeology, A Framework for the Eastern Counties*. East Anglian Archaeology Occasional Papers 3

Gurney, D., (2003), *Standards for field archaeology in the East of England*, East Anglian Archaeological, occasional papers 14 (EAA14)

Keen, D., (2015), 'The Farmyard, Brickyard Lane, Reed: A Written Scheme of Investigation' AES 2015.

Medlycott, M., & Brown N., (2008), *Revised East Anglian Archaeological Research Frameworks* [www.eaareports/algaoee](http://www.eaareports/algaoee)

Medlycott, M., (ed.), 2011, *Research and Archaeology revisited: a revised framework for the East of England*, ALGAO East of England Region, East Anglian Archaeology Occasional Papers 24.

National Policy Planning Framework, Policy 141, Department for Communities and Local Government 2012

Page. W., *Victoria County History. A History of the County of Hertfordshire Volume 3*, 1912

Waring, W. & Henry, K. *The Farmyard, Brickyard Lane, Reed, Hertfordshire, An Archaeological desk-based assessment*, Archaeological Solutions Limited June 2014

## SUPPORTING ILLUSTRATIONS

### APPENDIX 1: Site location

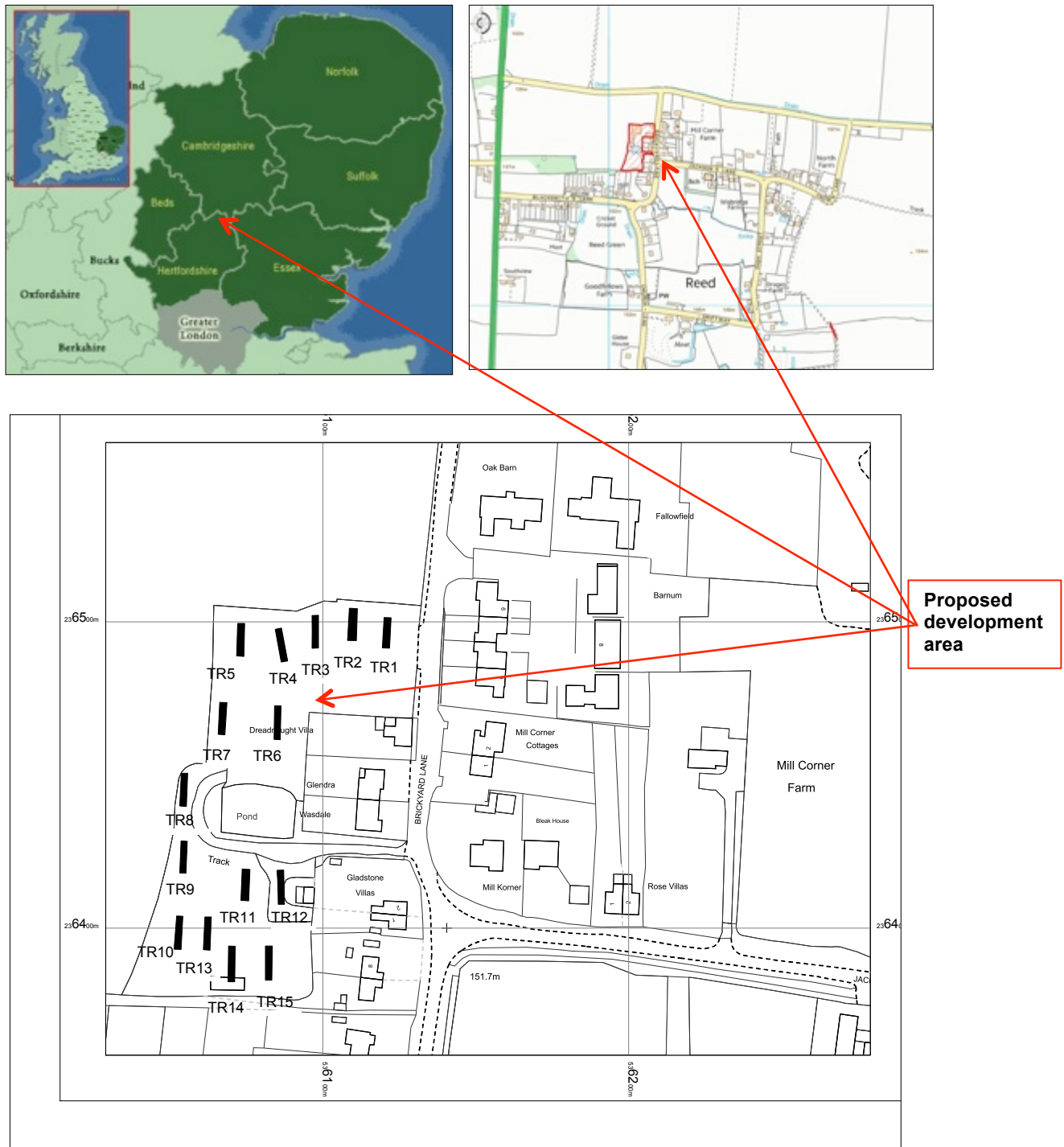

**Figure 1:** Site and trench location plans for The Farmyard, Brickyard Lane, Reed

© Crown Copyright All Rights Reserved Archaeology, Excavation & Surveys 100057973

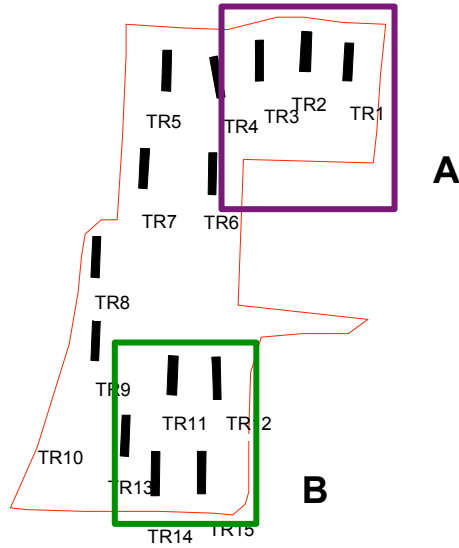

Figure 2 Areas of archaeological significance Brickworks (A) and Early 19<sup>th</sup> century Farm Buildings (B)



Figure 3 OS map of 1878

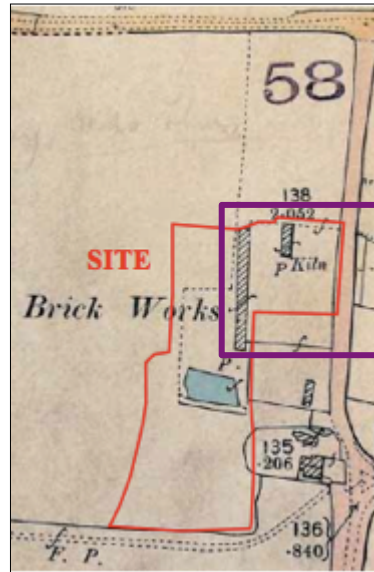

Figure 4 OS map of 1898

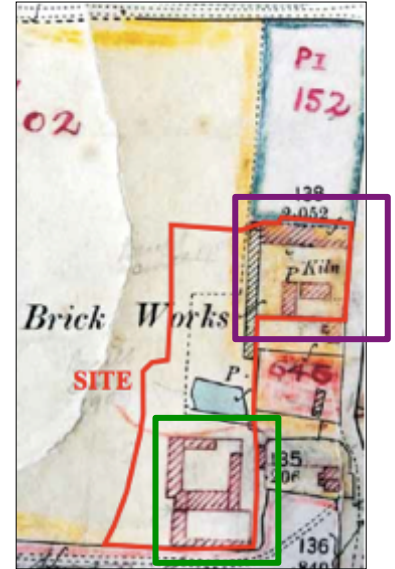

Figure 5 OS map of 1911

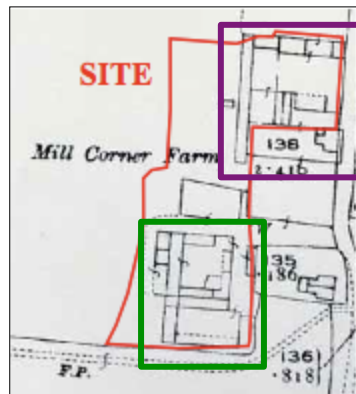

Figure 6 OS map of 1921

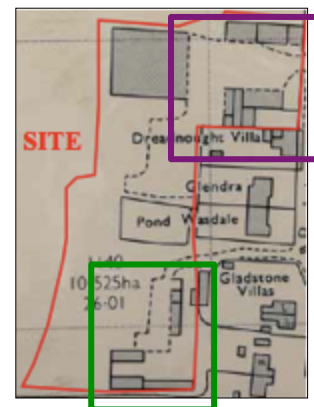

Figure 7 OS map of 1975

## APPENDIX 2: Site photographs

### Plan views



Figure 8 South facing view of Trench 1



Figure 9 South facing view of Trench 2



Figure 10 South facing view of Trench 3



Figure 11 South facing view of Trench 4



Figure 12 South facing view of Trench 5



Figure 13 South facing view of Trench 6



Figure 14 South facing view of Trench 7



Figure 15 South facing view of Trench 8



Figure 16 South facing view of Trench 9



Figure 17 South facing view of Trench 10



Figure 18 South facing view of Trench 11



Figure 19 South facing view of Trench 12



Figure 20 South facing view of Trench 13



Figure 21 North facing view of Trench 14



Figure 22 North facing view of Trench 15

**APPENDIX 3: Trench plans and sections**

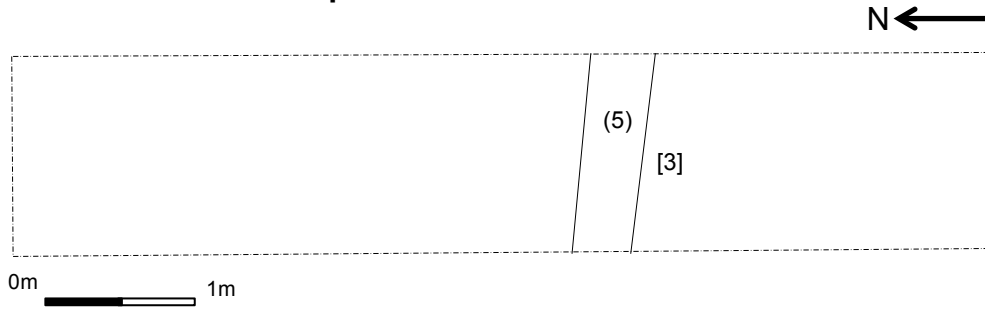

Figure 23 Plan view of Trench 1

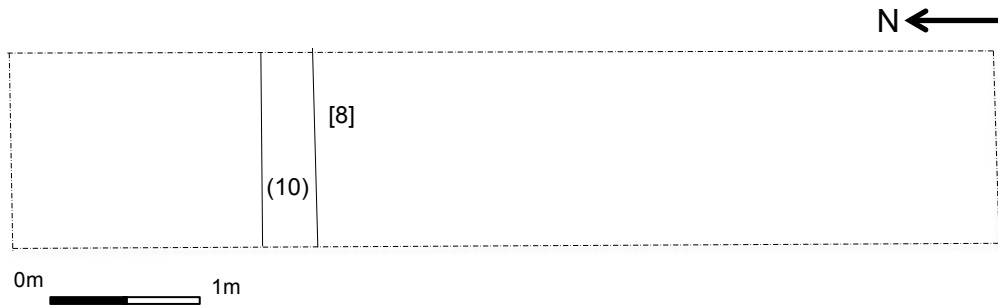

Figure 24 Plan view of Trench 2

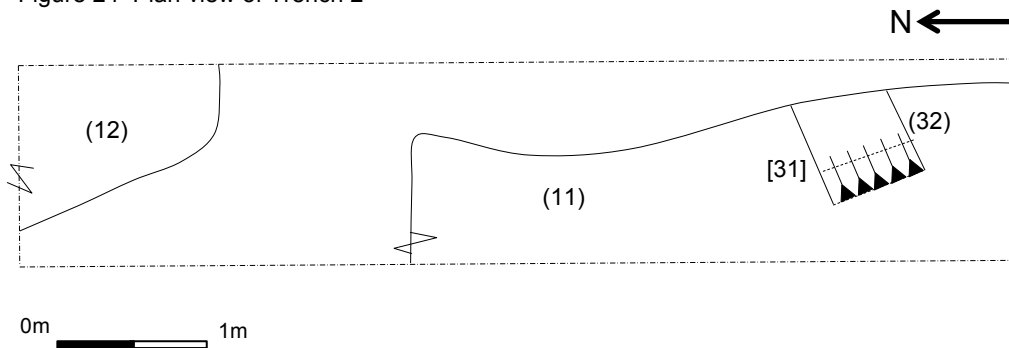

Figure 25 Plan view of Trench 3

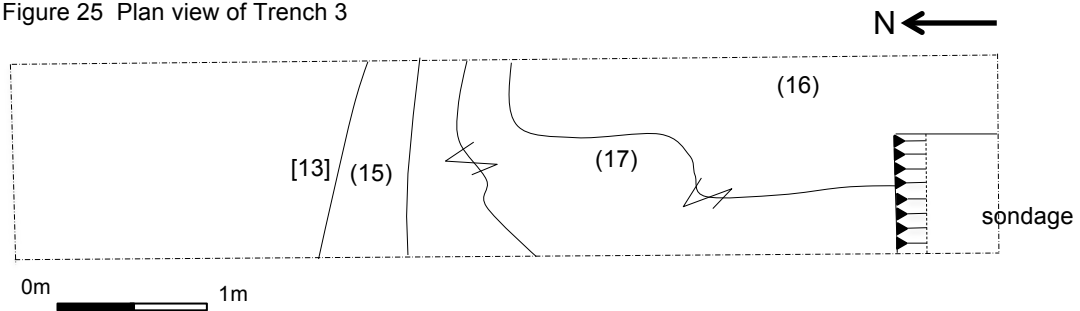

Figure 26 Plan view of Trench 4

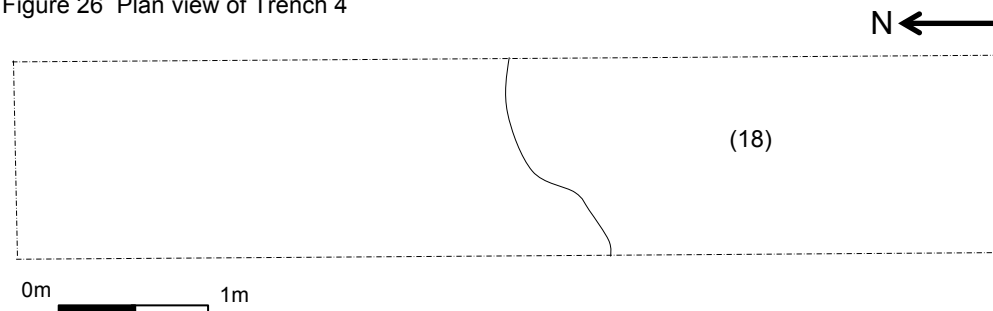

Figure 27 Plan view of Trench 5





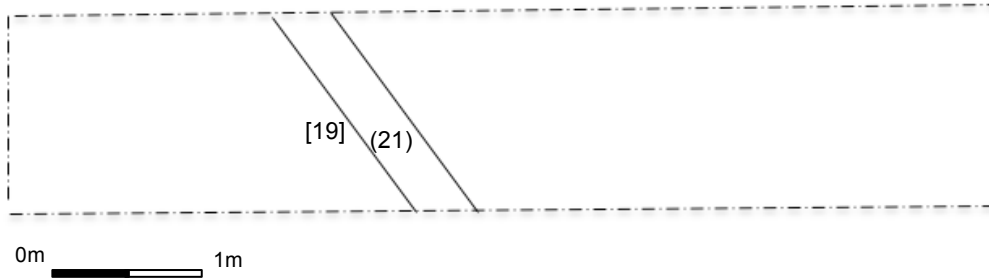

Figure 28 Plan view of Trench 6

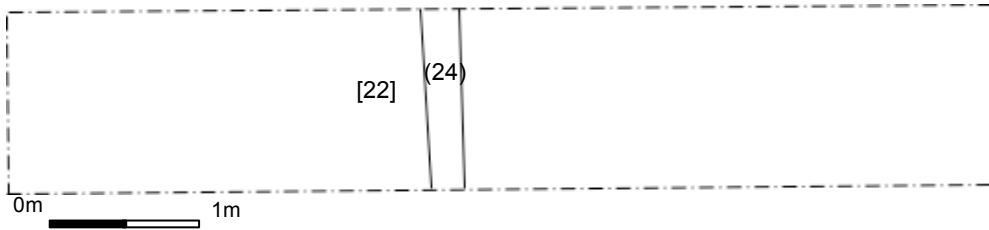

Figure 29 Plan view of Trench 7

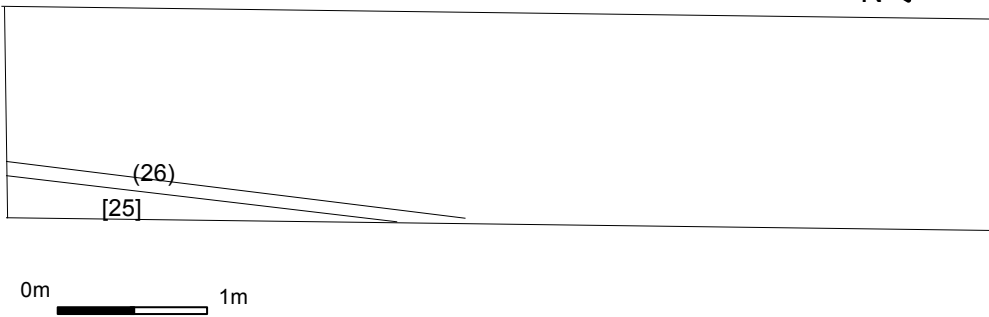

Figure 30 Plan view of Trench 8

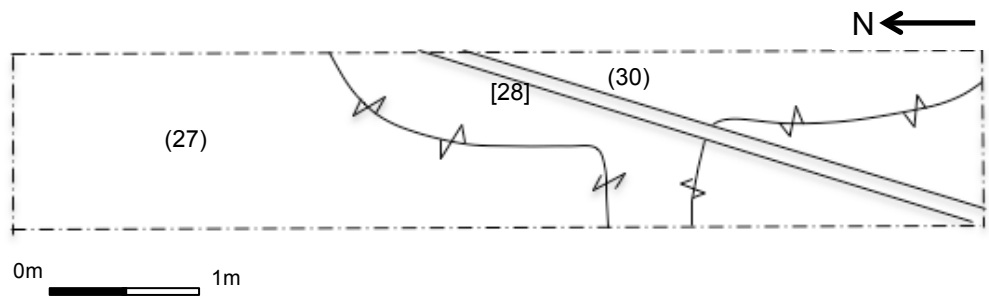

Figure 31 Plan view of Trench 9





Figure 32 Plan view of Trench 11

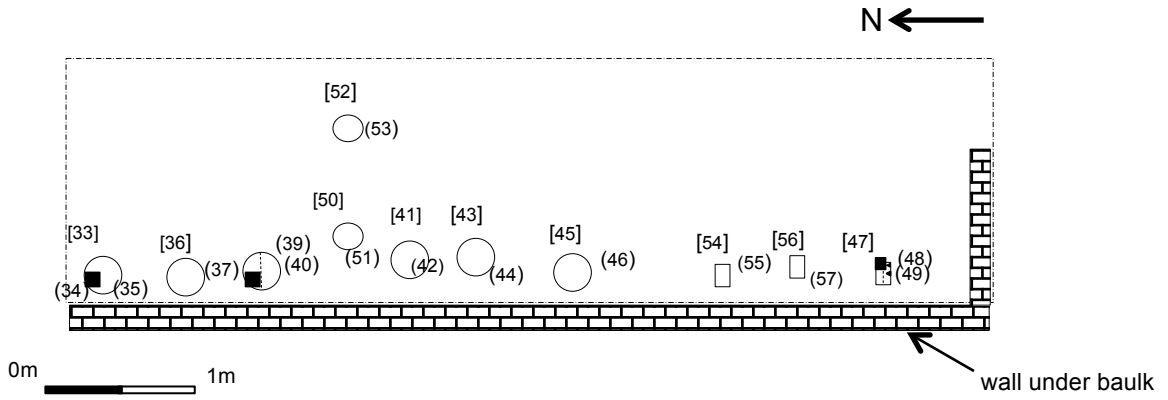

Figure 33 Plan view of Trench 13

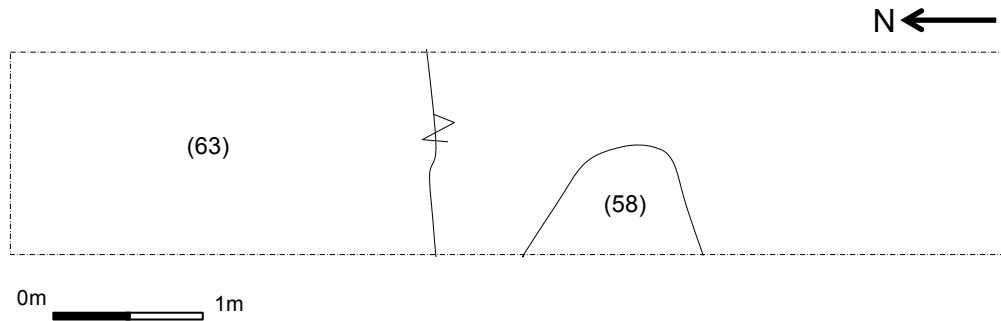

Figure 34 Plan view of Trench 14

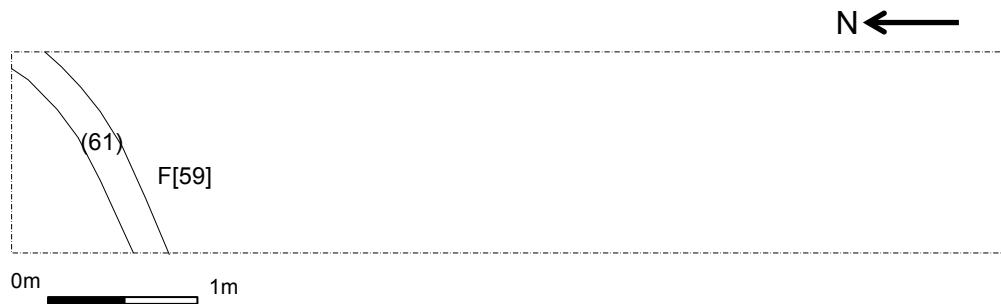

Figure 35 Plan view of Trench 15

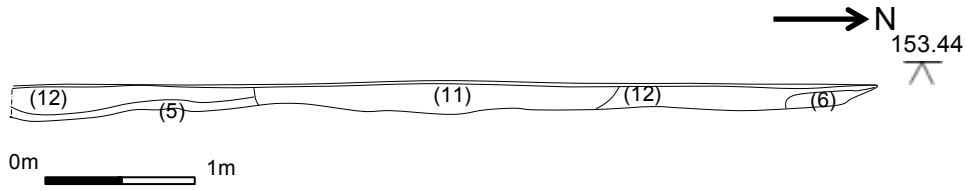

Figure 36 East facing section no 3 of Trench 3, Area A

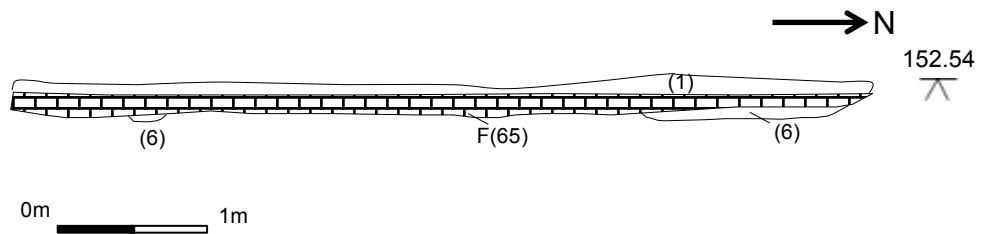

Figure 37 East facing section no 9 of Trench 13, Area B

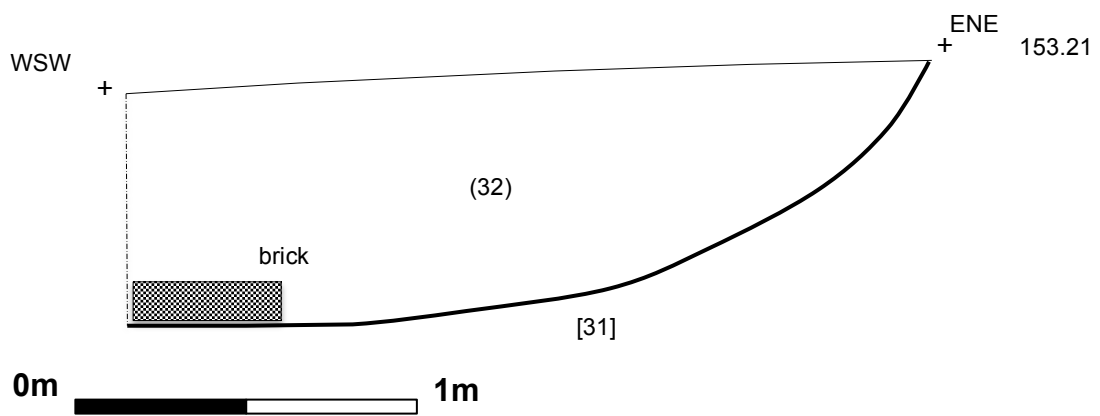

Figure 38 West South West facing section through linear [31]



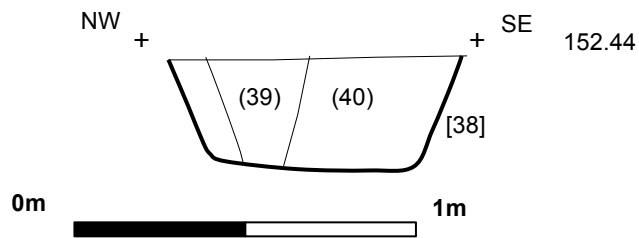

Figure 39 North West facing section through posthole [38]

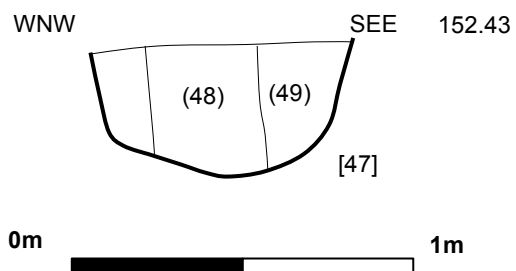

Figure 40 West North West facing section through posthole [47]

#### APPENDIX 4: Cartographic sources

See figures 3 to 7 Appendix 1



## **APPENDIX 5: Archive qualification (Site Code: REEDBL15)**

**Recorded Contexts:** 68 contexts

**Digital Photographic Archive:** 76 photographs

**Drawn Plans Archive:** 2 x A3 sheets at 1:50

**Drawn Sections Archive:** 1 x A3 sheets at 1:10

**Level Diary** Yes

**GPS plot:** Leica 1200 GPS Smart Rover with RTK differential correction giving global positioning accuracy to within 2cm

### **FINDS**

**Small Finds:** None

**Bulk Finds:** CBM.

### **Environmental Samples:**

**Level Diary:** See GPS Data

## APPENDIX 6: Finds quantification

Fill no	Cut no	Layer no	Trench No	Type	Weight (kg)	Date range
32	31		3	CBM		C19th
		12	3	Pot sherds	43	C19th
			12	Pot sherd	16	Ro
39	38		13	Fe nails x 3		C20th
48	47		13	Fe nails x 2		C20th

## APPENDIX 7: Context summary

Cxt No.	Tr. No.	Description	Interpretation	Date
		Topsoil	Little to non remaining	
1	1	Demolition	Layer	20 <sup>th</sup> century
2	1	Chalk	Layer – access road to Brickworks	19 <sup>th</sup> century
3	1	Land drainage	Cut of drain	20 <sup>th</sup> century
F4	1	Land drainage	Field drain [3]	20 <sup>th</sup> century
5	1	Land drainage	Fill of drain [3]	20 <sup>th</sup> century
6	2-8 13-15	Compact light-mid grey brown clay silt	Layer / subsoil	
7	2	Light orange/brown sandy silt	Layer – hardstanding farm buildings	20 <sup>th</sup> century
8	2	Land drainage	Cut of drain	19 <sup>th</sup> century
F9	2	Land drainage	Field drain [8]	19 <sup>th</sup> century
10	2	Land drainage	Fill of drain [8]	19 <sup>th</sup> century
11	3	Demolition rubble	Fill	20 <sup>th</sup> century
12	3	Demolition	Layer	20 <sup>th</sup> century
13	4	Land drainage	Cut of drain	19 <sup>th</sup> century
F14	4	Land drainage	Field drain [13]	19 <sup>th</sup> century
15	4	Land drainage	Fill of drain [13]	19 <sup>th</sup> century
16	4	1878 Brickworks: compacted chalk	Layer – access road	19 <sup>th</sup> century
17	4	Compact mid grey brown clay silt	Layer	19 <sup>th</sup> century
18	5	Chalk	Layer – access road	19 <sup>th</sup> century
19	6	Land drainage	Cut of drain	19 <sup>th</sup> century
F20	6	Land Drainage	Field drain [19]	19 <sup>th</sup> century
21	6	Land drainage	Fill of drain [19]	19 <sup>th</sup> century
22	7	Land drainage	Cut of drain	20 <sup>th</sup> century
F23	7	Land drainage	Field drain [22]	20 <sup>th</sup> century
24	7	Land drainage	Fill of drain [22]	20 <sup>th</sup> century
25	8	Land drainage	Cut of drain	19 <sup>th</sup> century
26	8	Land drainage	Gravel field drain [25]	19 <sup>th</sup> century
27	9	1911 Mill Corner Farm buildings: compacted chalk	Layer – hardstanding/roadway	20 <sup>th</sup> century
28	9	Land drainage	Cut of drain	19 <sup>th</sup> century
F29	9	Land drainage	Field drain [28]	19 <sup>th</sup> century
30	9	Land drainage	Fill of drain [28]	19 <sup>th</sup> century
31	3	1878 Brickworks	Cut of slot into brickworks remnants	19 <sup>th</sup> century
32	3	1878 Brickworks	Fill of cut [25]	19 <sup>th</sup> century
33	13	1911 Mill Corner Farm buildings	Cut of posthole	20 <sup>th</sup> century
34	13	1911 Mill Corner Farm buildings	Post [33]	20 <sup>th</sup> century
35	13	1911 Mill Corner Farm buildings	Fill of posthole [33]	20 <sup>th</sup> century
36	13	1911 Mill Corner Farm buildings	Cut of posthole	20 <sup>th</sup> century
37	13	1911 Mill Corner Farm buildings	Fill of posthole [36]	20 <sup>th</sup> century
38	13	1911 Mill Corner Farm buildings	Cut of posthole	20 <sup>th</sup> century
39	13	1911 Mill Corner Farm buildings	Post [38]	20 <sup>th</sup> century
40	13	1911 Mill Corner Farm buildings	Fill of posthole [38]	20 <sup>th</sup> century
41	13	1911 Mill Corner Farm buildings	Cut of posthole	20 <sup>th</sup> century
42	13	1911 Mill Corner Farm buildings	Fill of posthole [41]	20 <sup>th</sup> century
43	13	1911 Mill Corner Farm buildings	Cut of posthole	20 <sup>th</sup> century
44	13	1911 Mill Corner Farm buildings	Fill of posthole [43]	20 <sup>th</sup> century
45	13	1911 Mill Corner Farm buildings	Cut of posthole	20 <sup>th</sup> century
46	13	1911 Mill Corner Farm buildings	Fill of posthole [45]	20 <sup>th</sup> century
47	13	1911 Mill Corner Farm buildings	Cut of posthole	20 <sup>th</sup> century
48	13	1911 Mill Corner Farm buildings	Post [47]	20 <sup>th</sup> century
49	13	1911 Mill Corner Farm buildings	Fill of posthole [47]	20 <sup>th</sup> century
50	13	1911 Mill Corner Farm buildings	Cut of posthole	20 <sup>th</sup> century
51	13	1911 Mill Corner Farm buildings	Fill of posthole [50]	20 <sup>th</sup> century
52	13	1911 Mill Corner Farm buildings	Cut of posthole	20 <sup>th</sup> century
53	13	1911 Mill Corner Farm buildings	Fill of posthole [52]	20 <sup>th</sup> century



54	13	1911 Mill Corner Farm buildings	Cut of posthole	20 <sup>th</sup> century
55	13	1911 Mill Corner Farm buildings	Fill of posthole [54]	20 <sup>th</sup> century
56	13	1911 Mill Corner Farm buildings	Cut of posthole	20 <sup>th</sup> century
57	13	1911 Mill Corner Farm buildings	Fill of posthole [57]	20 <sup>th</sup> century
58	14	1911 Mill Corner Farm buildings	Brick layer	20 <sup>th</sup> century
F59	15	1975 Mill Corner Farm buildings	Cut of curvilinear cable trench	20 <sup>th</sup> century
60	15	1975 Mill Corner Farm buildings	Electric cable	20 <sup>th</sup> century
61	15	1975 Mill Corner Farm buildings	Fill of cable trench [59]	20 <sup>th</sup> century
62	11	1911 Mill Corner Farm buildings	Layer - hardstanding/roadway	20 <sup>th</sup> century
63	14	1911 Mill Corner Farm buildings	Layer - hardstanding/roadway	20 <sup>th</sup> century
64	14	1911 Mill Corner Farm buildings	Layer - hardstanding/roadway	20 <sup>th</sup> century
F65	13	1911 Mill Corner Farm buildings	Brick foundations	20 <sup>th</sup> century
F66	13	1911 Mill Corner Farm buildings	Group of postholes [33], [36], [38], [42], [45] and [48]	20 <sup>th</sup> century
F67	13	1911 Mill Corner Farm buildings	Group of postholes [47], [50], [52]	20 <sup>th</sup> century
F68	3	1878-1898 Brickworks	Brickworks remnants	19 <sup>th</sup> century

## APPENDIX 8: Photographic register

Photo reg no	Digital no	Direction taken from	Description of shot	Initials/date
1	7116	NW	Pre evaluation view of PDA	DEK 16/10/16
2	7117	NNW	Pre evaluation view of PDA	DEK 16/10/16
3	7118	NW	Pre evaluation view of PDA	DEK 16/10/16
4	7119	SW	Pre evaluation view of PDA	DEK 16/10/16
5	7120	SSW	Pre evaluation view of PDA	DEK 16/10/16
6	7121	SSE	Pre evaluation view of PDA	DEK 16/10/16
7	7122	SSE	Pre evaluation view of PDA	DEK 16/10/16
8	7123	SSE	Pre evaluation view of PDA	DEK 16/10/16
9	7124	SSE	Pre evaluation view of PDA	DEK 16/10/16
10	7125	NE	Pre evaluation view of PDA	DEK 16/10/16
11	7126	NE	Pre evaluation view of PDA	DEK 16/10/16
12	7127	NW	Pre evaluation view of PDA	DEK 16/10/16
13	7128	S	Trench 1 plan view	CJS/DK 19/10/16
14	7129	S	Trench 1 plan view	CJS/DK 19/10/16
15	7130	W	West facing section no 1 (north end)	CJS/DK 19/10/16
16	7131	W	West facing section no 1 (south end)	CJS/DK 19/10/16
17	7132	S	Trench 2 plan view	CJS/DK 19/10/16
18	7133	S	Trench 2 plan view	CJS/DK 19/10/16
19	7134	W	Trench 2 West facing section no 2 (north end)	CJS/DK 19/10/16
20	7135	W	Trench 2 West facing section no 2 (south end)	CJS/DK 19/10/16
21	7136	S	Trench 3 plan view	CJS/DK 19/10/16
22	7137	S	Trench 3 plan view	CJS/DK 19/10/16
23	7138	E	Trench 3 East facing section no 3 (south end)	CJS/DK 19/10/16
24	7139	E	Trench 3 East facing section no 3 (north end)	CJS/DK 19/10/16
25	7140	E	Trench 3 East facing section no 3 (north end)	CJS/DK 19/10/16
26	7141	S	Trench 4 plan view	CJS/DK 19/10/16
27	7142	S	Trench 4 plan view	CJS/DK 19/10/16
28	7143	W	Trench 4 West facing section no 4 (north end)	CJS/DK 19/10/16
29	7144	W	Trench 4 West facing section no 4 (south end)	CJS/DK 19/10/16
30	7145	S	Trench 5 plan view	CJS/DK 19/10/16
31	7146	W	Trench 5 West facing section no 5 (north end)	CJS/DK 19/10/16
32	7147	W	Trench 5 West facing section no 5 (south end)	CJS/DK 19/10/16
33	7148	W	Trench 5 West facing section no 5 (south end)	CJS/DK 19/10/16
34	7149	S	Trench 6 plan view	CJS/DK 19/10/16
35	7150	S	Trench 6 plan view	CJS/DK 19/10/16
36	7151	W	Trench 6 West facing section no 6 (north end)	CJS/DK 19/10/16
37	7152	W	Trench 6 West facing section no 6 (south end)	CJS/DK 19/10/16
38	7153	S	Trench 7 plan view	CJS/DK 19/10/16
39	7154	W	Trench 7 West facing section no 7 (north end)	CJS/DK 19/10/16
40	7155	W	Trench 7 West facing section no 7 (middle)	CJS/DK 19/10/16
41	7156	W	Trench 7 West facing section no 7 (south end)	CJS/DK 19/10/16
42	7157	S	Trench 8 plan view	CJS/DK 19/10/16
43	7158	W	Trench 8 West facing section no 8 (north end)	CJS/DK 19/10/16
44	7159	W	Trench 8 West facing section no 8 (south end)	CJS/DK 19/10/16
45	7160	S	Trench 9 plan view	CJS/DK 19/10/16
46	7161	W	Trench 9 West facing section no 9 (north end)	CJS/DK 19/10/16
47	7162	W	Trench 9 West facing section no 9 (north end)	CJS/DK 19/10/16
48	7163	W	Trench 9 West facing section no 9 (north end)	CJS/DK 19/10/16
49	7164	W	Trench 9 West facing section no 9 (south end)	CJS/DK 19/10/16
50	7165	S	Trench 10 Plan view	CJS/DK 19/10/16
51	7166	W	Trench 10 West facing section no 10 (north end)	CJS/DK 19/10/16
52	7167	W	Trench 10 West facing section no 10 (south end)	CJS/DK 19/10/16
53	7168	W	Trench 10 West facing section no 10 (south end)	CJS/DK 19/10/16
54	7174	W	Trench 11 West facing section no 11 (north end)	CJS/DK 19/10/16
55	7175	W	Trench 11 West facing section no 11 (south end)	CJS/DK 19/10/16
56	7176	S	Trench 11 plan view	CJS/DK 19/10/16
57	7177	S	Trench 12 plan view	CJS/DK 19/10/16
58	7178	W	Trench 12 West facing section no 12 (north end)	CJS/DK 19/10/16
59	7179	W	Trench 12 West facing section no 12 (south end)	CJS/DK 19/10/16
<b>Photo reg no.</b>				CJS/DK 19/10/16
60	7180	S	Trench 13 plan view	CJS/DK 19/10/16
61	7181	E	Trench 13 East facing section no 13 (south end)	CJS/DK 19/10/16

62	7182	E	Trench 13 East facing section no 13 (north end)	CJS/DK 19/10/16
63	7183	S	Trench 14 plan view	CJS/DK 19/10/16
64	7184	W	Trench 14 West facing section no 14 (north end)	CJS/DK 19/10/16
65	7185	W	Trench 14 West facing section no 14 (south end)	CJS/DK 19/10/16
66	7186	S	Trench 15 plan view	CJS/DK 19/10/16
67	7187	W	Trench 15 West facing section no 15 (north end)	CJS/DK 19/10/16
68	7188	W	Trench 15 West facing section no 15 (south end)	CJS/DK 19/10/16
69	7189	S	Trench 3 South facing section no 16 [31]	MB 21/10/15
70	7190	S	Trench 3 South facing section no 16 [31]	MB 21/10/15
71	7191	S	Trench 3 South facing section no 16 [31]	MB 21/10/15
72	7192	S	Trench 3 South facing section no 16 [31]	MB 21/10/15
73	7193	SW	Trench 13 South West facing section no 17 [38]	MB 21/10/15
74	7194	SW	Trench 13 South West facing section no 17 [38]	MB 21/10/15
75	7195	SW	Trench 13 South West facing section no 18 [47]	MB 21/10/15
76	7196	SW	Trench 13 South West facing section no 18 [47]	MB 21/10/15

## **APPENDIX 9: Specialists reports**

### **Brickwork from Old Farmyard, Brickyard Lane, Reed, Hertfordshire (Site REEDBL15)**

*Tom Doig* MA (Cantab.) MIMI PGCE FSG

This report considers a batch of red brick fragments and a single light tan coloured whole brick. It is understood that the samples came from the site of the abandoned brickworks at Mill Corner, Reed in Hertfordshire.

#### 1) The Fragments

These are from well-fired and moderately well-puddled local clay. The quality is much higher than that found at the brickworks at Puckeridge/Braughing (about 6 miles to the south), Hare Street/Buntingford, (about 4 miles south) and Hamels (a temporary brick-works) (about 5 miles south). Similar quality bricks were being manufactured at Morrice Green, Nuthampstead (about 3 miles east), up to the closure of those works in 1881.

The clay may contain an occasional white chalk or shell intrusion. All the bricks appear to have been hand-made in wooden moulds. The moulds had a very shallow frog insertion. The upper face of the bricks was cut using a flat-bladed strike which occasionally caught on protruding inclusions.

When the soft bricks were removed from the mould they were set to part-dry, probably in the adjacent open-sided brick drying sheds which can be identified on the early OS maps. The bricks were usually stacked edge upwards although these samples show no evidence of this procedure. Many other bricks used in the village of Reed (and most likely from the same brickworks) indicate that this was the normal method of drying.

The bricks were rather wetter than usual when they were stacked and some samples show sagging in the centre of the long face as the water was driven out. All are well-fired and show no evidence of over- or under-firing.

Considering the shallow frog and hand-moulding technique and other examples from dateable buildings in the locality, it could be suggested that the samples were manufactured during the mid1800s, possibly around the period 1850-1860.  
Dimensions: approx. 9.125" x 2.125" x 4.5"

One small red sample is not from a 'house' brick but rather from a pantile or drainage brick. Although it is large enough to give a definitive identification, the curve of its surface could be thought to be rather large for a drain tile and therefore the burden of probability suggests that it is part of a pantile. As the clay is similar to the majority of the fragments, a similar date could be implied.

#### 2) The 'light tan' brick

Again, this is a hand-made brick from a wooden mould. In many ways similar to the above, it does show a better quality of puddling with fewer large intrusions. It shows the marks made by the strike just prior to it being released from the mould. This example was stacked in the drying shed on its edge and one long, side face shows the impression of another damp brick being placed above it.

The brick was fired in a kiln and was given slightly less than the optimum length of time (or possibly the kiln did not reach its full temperature) as the inner core of the brick does not show the rich tan colour of the 'skin'. Other evidence of the rather under-firing are the minor cracks on the upper face where the brick had sagged in the kiln.

Although the colour of this example does not show the rich redness of the fragments it is probably that that it was manufactured at Reed. However, it should be borne in mind that by the 1850/60s, when this example was made, the railway had come to nearby Royston and the brick may have been imported.

That this brick is of the dimensions of the traditional 'Tudor Brick' should not be used as evidence of such an early date. Many buildings in Reed contain such bricks as structural and occasionally, decorative.  
Dimensions: approx. 9" x 4.5" x 1.75"

**Pottery from Old Farmyard, Brickyard Lane, Reed, Hertfordshire  
(Site REEDBL15)**

*Paul Blinkhorn*

The pottery assemblage comprised five sherds with a total weight of 59g. It was all unstratified.

Four sherds weighing 43g occurred in Trench 3. They are all from the same vessel, a 19<sup>th</sup> century white earthenware tea-pot with a manganese glaze. A single sherd weighing 16g came from Trench 12. It is a rimsherd from a Romano-British sandy grey ware jar. Such pottery is common throughout the Romano-British period (Tomber and Dore 1998). It is slightly abraded, but otherwise in good condition.

**Bibliography**

Tomber, R, and Dore, J, 1998 *The National Roman Fabric Reference Collection: A Handbook* Museum of London/English heritage/British Museum

## APPENDIX 10: Metal detecting report

### Metal finds from the Reed, Brickyard Lane (Site REED/BL/15)

*Robert Parker*

ON BEHALF of ARCHAEOLOGY, EXCAVATION & SURVEYS

Fifteen trenches and spoil heaps were surveyed as requested. Metal objects found dated to the 18<sup>th</sup> -19<sup>th</sup> century. A high level of metal working activity was noted due to industrial iron waste workings and debris round the site.



A1 POST MED 18<sup>TH</sup>-19<sup>TH</sup> CENTURY LIVERY BUTTON  
LOCATION TRENCH 3



A2 19<sup>TH</sup> CENTURY MACHINE PLATE  
LOCATION TRENCH 5



A3 18<sup>TH</sup>-19<sup>TH</sup> CENTURY THIMBLE  
LOCATION TRENCH 6

## APPENDIX 11 HERTFORDSHIRE HISTORIC ENVIRONMENT RECORD SUMMARY SHEET

Site name and address: The Farmyard, Brickyard Lane, Reed, Hertfordshire		
County: Hertfordshire	District: North Hertfordshire	
Village/Town: Reed	Parish: Reed	
Planning application reference: 15/1725/1		
HER Enquiry reference: 196/16		
Funding source: Commercial		
Nature of application: Commercial		
Present land use: Agricultural and Industrial		
Size of application area: 0.66 ha	Size of area investigated: 0.66ha	
NGR (to 8 figures minimum): TL3608 3646		
Site code (if applicable): REEDBL15		
Site director/Organization: Archaeology, Excavation and Surveys.		
Type of work: Archaeological Evaluation		
Date of work:	Start: 18 <sup>th</sup> October	Finish: 21 <sup>st</sup> October
Location of finds & site archive/Curating museum: Stored at present in AES offices to be deposited with appropriate Hertfordshire Museum		
Related HER Nos: 11427, 15082, 15352. EHT4688, EHT7091, EHT4980, EHT7780	Periods represented: Medieval, Post-medieval	
Relevant previous summaries/reports Doel, Peter. 1999. Mill Korner, Jacksons Lane, Reed: archaeological observation and recording. watching brief. RNO 893 Waring, William. 2014. The Farmyard, Brickyard Lane, Reed, Hertfordshire: an archaeological desk-based assessment. desk-based assessment. RNO 3298		
Summary of fieldwork results: <i>Archaeology, Excavation and Surveys completed an archaeological trenched evaluation between the 18th October 2016 to 21st October 2016 on approximately 0.66 hectares of former agricultural and industrial land on the edge of Reed village, in response to a planning requirement set by Andy Instone of Hertfordshire Environment Team prior to the development of the Proposed Development Area (PDA) with twelve dwellings, associated services and access (planning refs: 14/02573/1 &amp; 15/01725/1). Fifteen linear trenches totaling 150m in length, representing a 5% sample of the total Proposed Development Area (PDA), were opened using a 20 tonne 360 degree excavator with toothless ditching bucket under archaeological supervision. The investigation primarily revealed the Proposed Development Area's (PDA) historic use for agriculture and industry, dating from the mid 19th century. Modern overburden was found in all trenches representing the demolition of farm buildings prior to archaeological investigations (Waring, 2014). Trenches 1, 4, 5, 9, 11, 14 and 15 contained layers of granulated chalk not found in trenches 2, 3, 6, 7, 8, 10, 12 and 13 possibly the hardstanding and access road to the Brickworks and Mill Corner Farm. A sandy layer was also present in trench 2, also possibly part of the latter. Archaeological features revealed included 9 in 12 of the trenches opened. Two areas of archaeological significance were recorded (figure 2, Areas A and B). Features in trenches 2, 4 and 6, revealed linears containing 19th century clay drains and in trenches 8, and 9 gravel drains. Features in trench 3 revealed a large area of brick rubble and brick dust relating to the sites use during the 19th century as a Brickworks. Trench 3 also contained four sherds of 19th century white earthenware tea-pot with a manganese glaze (Blinkhorn, 2016), brick fragments and a single light tan brick (Doig, 2016). Features in trench 13 revealed evidence of early 19th century Mill Corner Farm buildings in the form of brick footings and postholes, possibly relating to Mill Corner Farm. Trenches 10 and 12 revealed no features of archaeological activity. Modern features were revealed in trenches 1, 7 and 15, two linears and a curvilinear which contained two drains, one made of plastic, the other in the form of bakelite, and an electric cable. Ordnance survey (OS) maps from 1878 to 1911 show the presence of the brickworks, but which are no longer evident on the 1921 OS map. From the 1921 OS map, Mill Corner Farm is shown occupying the southern half of the PDA, however on the 1975 OS map only Farm buildings remain, Mill Corner Farm itself being relocated. Although the site lies in close proximity to Roman Ermine Street, only a single rim sherd of Romano- British Grey Ware revealed evidence of Roman activity, found in Trench 12 (Blinkhorn, 2016). Additionally, metal detecting of spoil above trenches 3, 5 and 6 recovered an 18th-19th century livery button, 19th century machine plate and 18th-19th century thimble (Parker, 2016).</i>		
Author of summary: Dawn Keen	Date of summary: 9th December 2016	



## APPENDIX 12: Oasis form

AES OASIS Report Form

OASIS ID Number: archaeol15-209807

PROJECT DETAILS			
Project Name:		The Farmyard, Brickyard Lane, Reed. An Archaeological Trenched Evaluation	
Short Description:		<p><i>Archaeology, Excavation and Surveys completed an archaeological trenched evaluation between the 18<sup>th</sup> October 2016 to 21<sup>st</sup> October 2016 on approximately 0.66 hectares of former agricultural and industrial land on the edge of Reed village, in response to a planning requirement set by Andy Instone of Hertfordshire Environment Team prior to the development of the Proposed Development Area (PDA) with twelve dwellings, associated services and access (planning refs: 14/02573/1 &amp; 15/01725/1).</i></p> <p><i>Fifteen linear trenches totaling 150m in length, representing a 5% sample of the total Proposed Development Area (PDA), were opened using a 20 tonne 360 degree excavator with toothless ditching bucket under archaeological supervision.</i></p> <p><i>The investigation primarily revealed the Proposed Development Area's (PDA) historic use for agriculture and industry, dating from the mid 19th century.</i></p> <p><i>Modern overburden was found in all trenches representing the demolition of farm buildings prior to archaeological investigations (Waring, 2014).</i></p> <p><i>Trenches 1, 4, 5, 9, 11, 14 and 15 contained layers of granulated chalk not found in trenches 2, 3, 6, 7, 8, 10, 12 and 13 possibly the hardstanding and access road to the Brickworks and Mill Corner Farm. A sandy layer was also present in trench 2, also possibly part of the latter.</i></p> <p><i>Archaeological features revealed included 9 in 12 of the trenches opened. Two areas of archaeological significance were recorded (figure 2, Areas A and B).</i></p> <p><i>Features in trenches 2, 4 and 6, revealed linears containing 19<sup>th</sup> century clay drains and in trenches 8, and 9 gravel drains. Features in trench 3 revealed a large area of brick rubble and brick dust relating to the sites use during the 19<sup>th</sup> century as a Brickworks. Trench 3 also contained four sherds of 19<sup>th</sup> century white earthenware tea-pot with a manganese glaze (Blinkhorn, 2016), brick fragments and a single light tan brick (Doig, 2016). Features in trench 13 revealed evidence of early 19<sup>th</sup> century Mill Corner Farm buildings in the form of brick footings and postholes, possibly relating to Mill Corner Farm. Trenches 10 and 12 revealed no features of archaeological activity.</i></p> <p><i>Modern features were revealed in trenches 1, 7 and 15, two linears and a curvilinear which contained two drains, one made of plastic, the other in the form of bakelite, and an electric cable.</i></p> <p><i>Ordnance survey (OS) maps from 1878 to 1911 show the presence of the brickworks, but which are no longer evident on the 1921 OS map. From the 1921 OS map, Mill Corner Farm is shown occupying the southern half of the PDA, however on the 1975 OS map only Farm buildings remain, Mill Corner Farm itself being relocated.</i></p> <p><i>Although the site lies in close proximity to Roman Ermine Street, only a single rim sherd of Romano-British Grey Ware revealed evidence of Roman activity, found in Trench 12 (Blinkhorn, 2016). Additionally, metal detecting of spoil above trenches 3, 5 and 6 recovered an 18<sup>th</sup>-19<sup>th</sup> century livery button, 19<sup>th</sup> century machine plate and 18<sup>th</sup>-19<sup>th</sup> century thimble (Parker, 2016).</i></p>	
Project Dates:	S t a r t	18th October 2016	E n d
			21 <sup>st</sup> October 2016
Previous work:	No	Future work:	Yes No
Associated Project Reference Codes:		REEDBL15	
Type of Project:		Archaeological Trenched Evaluation	
Site Status:		None	
Current land use: (list all that apply)		Agricultural	
Planned development:		Residential	

Monument types/period (list all that apply)		Brickworks including drying sheds and kiln. Farm buildings			
Significant finds: Artefact type / period (List all that apply)		Post-Medieval			
<b>PROJECT LOCATION</b>					
County:	Hertfordshire	Parish:	Reed		
HER for region:		Hertfordshire			
Site address: (including postcode)		The Farmyard, Brickyard Lane, Hertfordshire			
Study area (sq m or ha)		0.66 hectare			
<b>National Grid Reference</b>	Easting (6 figures)	TL 3608	Northing (6 figures)	3646	
<b>Height OD</b>	Max OD	154.27	Min OD	152.54	
<b>PROJECT ORIGINATORS</b>					
Organisation:		Archaeology, Excavation & Surveys			
Project brief originator:		Andy Instone			
Project design originator:		Simon Bray			
Sponsor or funding body:		Developer			
<b>ARCHIVES</b>	<b>Location and accession number</b>		<b>Content (eg. Pottery, animal bone, database, context sheet etc)</b>		
Physical	Hertfordshire Museum Service		CBM		
Paper	Hertfordshire Museum Service		Context sheets, plans, sections		
Digital	AES		Report, illustrations		
<b>BIBLIOGRAPHY</b>					
Full title:		The Farmyard, Brickyard Lane, Reed: An Archaeological Investigations: Trenched Evaluation			
Report No.:		AES/2015/14			
Series title and volume:					
Page numbers:		43			
Author(s)		Dawn Keen BA MA PCIFA			

## APPENDIX 13.0: Strip, Map and Record Report February 2017

### Archaeological Investigations: Strip, Map and Record

#### **Non-technical Summary**

Archaeology, Excavation and Surveys completed an archaeological strip, map and record between the 15th December 2016 to 12<sup>th</sup> January 2017 on approximately 0.20 hectares of former agricultural and industrial land on the edge of Reed village, in response to a planning requirement set by Andy Instone of Hertfordshire Environment Team prior to the development of the Proposed Development Area (PDA) with twelve dwellings, associated services and access (planning refs: 14/02573/1 & 15/01725/1).

The investigation discovered nine phases of activity on the Proposed Development Area (PDA) and primarily revealed the PDA's historical use as a brickworks and as a farm, dating it from the 19th Century. Within this, eight phases and seventeen groups were identified; **phase one** – pre 1878 activity; **phase two** - 1878-1898 Brickwork remnants; **phase three** - 1911 Brickwork remnants; **phase four** - 1911 Area B Mill Corner Farm; **phase five** - 1921 Area A Mill Corner Farm; **phase six** – 1921 Area B Mill Corner Farm; **phase seven** - 1975 Agricultural/industrial buildings Areas A/B; **phase eight** - Post 1975 activity Areas A/B; **phase nine** - Undated.

Modern overburden was found over the site within Areas A and B representing the demolition of farm buildings prior to archaeological investigations (Waring, 2014).

The layer of modern overburden covered layers of granulated chalk, possibly the hardstanding and access road to the Brickworks and Mill Corner Farm in Area A. A sandy layer was also present in Area A. The brick foundations of a thatched cottage consisting of three bedrooms, a pantry and attached drying shed, and possible remnants of a brick-built kiln were also found in Area A along with associated 19<sup>th</sup> century clay drains, and also brick remnants of 20<sup>th</sup> century Mill Corner Farm and associated drains. A large area of brick rubble and dust relating to the sites use during the 19<sup>th</sup> century as a Brickworks was also revealed in Area A. A further single light tan brick to that found in the evaluation was found at the southern end of Area A (Doig, 2016).

The layer of modern overburden also covered layers of mortar/concrete flooring, granulated chalk and brick foundations of Mill Corner Farm with associated posted outbuildings and 20th century clay drains in Area B. No archaeological stratified finds were recovered.

Modern features revealed in Area A included a linear feature containing a water pipe and two investigation slots. In Area B two further investigation slots were revealed.

Ordnance survey (OS) maps from 1878 to 1911 (figures 3 and 4) show the presence of the brickworks, but which are no longer evident on the 1921 OS map (figure 6). From the 1921 OS map, Mill Corner Farm is shown occupying the southern half of the PDA, however on the 1975 OS map (figure 7) only Farm buildings remain, Mill Corner Farm itself having being relocated.

Additionally, metal detecting of Area B recovered a 19th century RAF shirt button, 19th century latch key and 19th century brass door knob (Parker, 2017).

## Contents

Non-technical summary		
10.0	Introduction	1
11.0	Strip, Map and Record: Results	1
11.1	Phase 1 Pre 1878 activity	2
11.2	Phase 2 Brickworks 1878-1898	2
11.3	Phase 3 1911 Brickworks	3
11.4	Phase 4 1911 Mill Corner Farm	3
11.5	Phase 5 1921 Brickworks	6
11.6	Phase 6 1921 Mill Corner Farm	6
11.7	Phase seven 1975 Agricultural/industrial buildings	9
11.8	Phase eight Post 1975 activity	9
2.9	Phase nine Undated	9
12.0	Metal detectorist survey	10
13.0	Conclusions	10

## SUPPORTING ILLUSTRATIONS

### APPENDICES

- APPENDIX 1: Site location
- APPENDIX 2: Site photographs
- APPENDIX 3: Plans and sections
- APPENDIX 4: Archive sources
- APPENDIX 5: Archive qualification (Site Code: REEDBL15)
- APPENDIX 6: Finds quantification
- APPENDIX 7: Context summary
- APPENDIX 8: Photographic Register
- APPENDIX 9: Metal detecting report
- APPENDIX 10: HER Summary Sheet

### FIGURES

- Figure 1: Areas of archaeological significance Brickworks (A) and Mill Corner Farm (B)
- Figure 2: Ordnance Survey map of 1878
- Figure 3: Ordnance Survey map of 1898
- Figure 4: Ordnance Survey map of 1911
- Figure 5: Ordnance Survey map of 1921
- Figure 6: Ordnance Survey map of 1975
- Figure 7: North facing view of brick foundations
- Figure 8: South facing view of brick foundations
- Figure 9: South East facing view of brick foundations and 1911 kiln location
- Figure 10: East facing view of brick foundations
- Figure 11: East facing view of brick foundations
- Figure 12: North East facing view of brick foundations
- Figure 13: West facing view of Mill Corner Farm 1 of 3
- Figure 14: West facing view of Mill Corner Farm 1 of 3
- Figure 15: West facing view of Mill Corner Farm 2 of 3
- Figure 16: South facing view of Mill Corner Farm 1 of 4
- Figure 17: South facing view of Mill Corner Farm 2 of 4
- Figure 18: South facing view of Mill Corner Farm 3 of 4
- Figure 19: South facing view of Mill Corner Farm 4 of 4
- Figure 20: South East facing view of Mill Corner Farm 1 of 2
- Figure 22: South East facing view of Mill Corner Farm 2 of 2
- Figure 23: North facing view of Mill Corner Farm 1 of 2
- Figure 24: North facing view of Mill Corner Farm 2 of 2
- Figure 25: East facing view of Mill Corner Farm 1 of 4
- Figure 26: East facing view of Mill Corner Farm 2 of 4
- Figure 27: East facing view of Mill Corner Farm 3 of 4
- Figure 28: East facing view of Mill Corner Farm 4 of 4
- Figure 29: North facing view of section no 4
- Figure 30: South facing view of drains F(4), F(5), F(6) and brick pad F(8) locations
- Figure 31: Plan view of brick pad F(8)
- Figure 32: Plan view of drain F(4)
- Figure 33: Plan view of drain F(5)

- Figure 34: North facing view of drain F(87) and F(88)
- Figure 35: Plan view of drain F(87) F(88)
- Figure 36: West facing view of wall F(25) and drain F(98)
- Figure 37: North facing view of drain F(98) and doorway F(99)
- Figure 38: Plan view of drain construction F(101)
- Figure 39: West facing section of external wall F(55)
- Figure 40: East facing section of external wall F(68)
- Figure 41: West facing section of internal wall F(68)
- Figure 42: South facing section of internal wall F(56)
- Figure 43: North facing section of internal wall F(57)
- Figure 44: North facing section of wall external F(56)
- Figure 45: Posthole [35] location within Mill Corner Farm
- Figure 46: Plan view of posthole [35]
- Figure 47: Posthole/pit [47] location within Mill Corner Farm
- Figure 48: Plan view of posthole/pit [47]
- Figure 49: Plan view of post and packing [45]
- Figure 50: Side view of post and packing [45]
- Figure: 51: Posthole [127] location within Mill Corner Farm (MCF)
- Figure 52: South facing view of posthole [127]
- Figure 53: Post and packing [72], location within MCF
- Figure 54: South facing view of post and packing [72]
- Figure 55: Post and packing [72], location within MCF
- Figure 56: South facing view of post hole [127]
- Figure 57: Rectangular slot [134] and drain [136] location within MCF
- Figure 58: South facing view of drain cut [163]
- Figure 59: South facing view of rectangular slot [134]
- Figure 60: Drain base F(6)
- Figure 61: Drain base F(24)
- Figure 62: Drain base F(87)
- Figure 63: Drain base F(136)
- Figure 64: Drain tiles F(101)
- Figure 65: Brick F(30) with makers mark
- Figure 66: Flooring F(59)
- Figure 67: Plan view of Area A showing remnants of Brickworks, Thatched Cottage and Mill Corner Farm
- Figure 68: Plan view of Area A south end
- Figure 69: Plan view of Area B Mill Corner Farm
- Figure 70: Plan view of Area B Mill Corner Farm, after removal of rubble layer (76)
- Figure 71: Phase two Area A 1878-1898 Brickworks
- Figure 72: Phase two Area A 1878-1898 Brickworks – southern end
- Figure 73: Phase three Area A 1911 Brick works
- Figure 74: Phase four Area B 1911 Mill Corner Farm
- Figure 75: Phase five Area A 1921 Mill Corner Farm
- Figure 76: Phase six Area B 1921 Mill Corner Farm
- Figure 77: Phase seven Area A 1975 Mill Corner Farm
- Figure 78: Phase seven Area B 1975 Mill Corner Farm
- Figure 79: Phase eight Area A post 1975 activity
- Figure 80: Phase eight Area B post 1975 activity
- Figure 81: Phase nine: Area A undated activity
- Figure 82: North facing section no 4 of layers (1), (2) and (155)
- Figure 83: West facing section no 1 of wall remnants F(30) southern end
- Figure 84: West facing section no 2 of wall remnants F(25) and drain F(98)
- Figure 85: West facing section no 2 showing brick construction of wall F(25) - 5 courses with footing
- Figure 86: North facing section no 3 of drain F(98) and wall F(99)
- Figure 87: North facing section no 3 showing brick construction of wall F(99) - 4 courses with footing
- Figure 88: North facing section no 13 of wall remnants F(56)
- Figure 89: North facing section no 14 showing brick construction of wall (F56) - 2 courses
- Figure 90: North facing section no 15 showing brick construction of wall F(56) – 3 courses with footing
- Figure 91: Plan view of north facing section no 15 showing brick construction of wall F(56)
- Figure 92: West facing sections no 18 and 19 of wall remnants F(68)
- Figure 93: West facing section no 19 showing brick construction of wall F(68) - 2 courses
- Figure 94: Plan view of west facing section no 19 showing brick construction of wall F(68)
- Figure 95: West facing section no 20 of wall remnants F(54) and F(55)

- Figure 96: West facing section no 21 showing brick construction of wall F(55) – 2 courses  
Figure 97: Plan view of west facing section no 20 showing brick construction of wall F(55)  
Figure 98: Plan view of post hole [35]  
Figure 99: South facing view of post hole [35]  
Figure 100: Plan view of post hole [47]  
Figure 101: South facing view of post hole [47]  
Figure 102: Plan view of post hole [73]  
Figure 103: South facing view of post hole [73]  
Figure 104: Plan view of post hole [116]  
Figure 105: South facing view of pit/post hole [116]  
Figure 106: Plan view of post hole [119]  
Figure 107: South facing view of post hole [119]  
Figure 108: Plan view of slot [134] and drain cut [163]  
Figure 109: North facing view of slot [134]  
Figure 110: Archive sources

## 1.0 Introduction

An archaeological strip, map and record was carried out at The Farmyard, Brickyard Lane, Reed, by Archaeology, Excavation and Surveys (AES), from 15<sup>th</sup> December 2016 to 12<sup>th</sup> January 2017 inclusive, as required by Senior Archaeologist Andy Instone of Hertfordshire County Council Historic Environment Team.

The strip, map and record followed on from an evaluation carried out from 18<sup>th</sup> October 2016 to 21<sup>st</sup> October 2016 and the results have been included as an appendix within the evaluation report, therefore there has been minimal repetition of information already included within the latter. The methodology has been written as a separate document and issued prior to the Strip, Map and Record to the HCC HET.

Further to the evaluation, the strip, map and record revealed archaeological activity relating to the sites use for agriculture, however due to extensive contamination within Area A, on discussion with Andy Instone from the HCC HET and Richard Tiffin from HCC planning team, it was deemed that for Health and Safety reasons excavation was not possible. Minimal recording therefore, in the form of photographs, plans and sections, was carried out in Area A.

*Contaminates in Area A consisted of:*

*Asbestos – within drains F(22), F(23), investigation slot F(26), beneath hardstanding of entrance road, and asbestos roofing remnants spread across Area A.*

*Extractable Ammonia –the results of the chemical analysis identified the presence of between 1600mg/kg and 2200mg/kg extractable ammonium within the samples (Miles, 2017), which covered the area between Thatched cottage/drying shed brick foundations F(25),F (28), F(29) F(30), spread into layer (17) and postholes F(18), F(19), F(104), F(105), southwards at least to the boundary of drain F(22), east to the baulk boundary and north to brick foundationsF (27) and beyond.*

A representative sample of differing types of feature revealed were excavated within Area B.

The site, consisting of 0.20ha, was stripped for the map and record by a 16 tonne tracked excavator with toothless ditching bucket.

## 2.0 Strip, Map and Record: results

### Overview of results

The period of activity on the site at Brickyard Lane can be divided into nine phases and twenty six groups, all contexts within these phases and groups are listed in the context summary in Appendix 7.0.

Phase 1.	Pre 1878 activity
Phases 2 to 3	1878 to 1911 Brickworks (divided into 4 groups)
Phases 4 to 6	1911 to 1921 Mill Corner Farm (divided into 18 groups)
Phase 7	1975 Agricultural/Industrial buildings
Phase 8	Post 1975 activity Areas A and B (divided into 3 groups)
Phase 9	Undated activity

A total of 164 contexts were excavated and recorded, and artefacts in the form of ceramic building material were recovered and catalogued. A full context list can be found in Appendix 7.

## **Results**

### **2.1 Phase 1 Pre 1878 activity**

No archaeological features or finds were recovered.

### **2.2 Phase 2 1878 – 1898 brickworks**

This phase represents the period of brickwork operation as depicted on the OS maps of 1878 and 1898 and within Area A (figure 1). The archaeological activity on the site consists of 6 brick post pads, 4 drains and the foundations of a 19<sup>th</sup> century brick built thatched cottage of 3 rooms with a thatched drying shed attached and brick-built kiln (figure 110).

Layer (2) is comprised of a hardpacked chalk lump. It overlies the natural clay and lies beneath modern demolition layer (1) and measured  $\leq 2.35\text{m}$  (w) x  $\leq 0.40\text{m}$  (d) in section (figure 82).

No datable material was recovered.

Layer (17) is comprised of a dark red clay with frequent brick fragments. It was cut into the natural clay and lies beneath modern demolition layer (1) and measured  $\leq 12.3\text{m}$  (l) x  $\leq 2.3\text{m}$  (w) x  $\leq 0.45\text{m}$  (d) (ref: evaluation report, p5 (12)).

Brick remnants dateable to the mid 19<sup>th</sup> century were recovered (Doig, 2017 in Keen, 2016).

Layer (94) is comprised of bricks in rectangular formation, and measured  $\leq 1.0\text{m}$  (l) x  $\leq 0.8\text{m}$  (w) x  $\leq 0.6\text{m}$  (d).

**Phase 2 group one** consists of brick post pads possibly associated the kiln structure depicted on the OS map of 1878-1898 (figures 2 and 3). The post pads within this group total six F(7), F(8), F(9), F(10), F(11) and F(12).

The brick pads varied in shape from  $\leq 0.5\text{m}$  (l) to  $\leq 1.0\text{m}$  (l) x  $\leq 0.05\text{m}$  (w) to  $\leq 0.07\text{m}$ .

Brick pad F(11) was rectangular in shape and measured  $\leq 1.0\text{m}$  (l) x  $\leq 0.70\text{m}$  (w), with a top fill of orange/grey silt clay, with inclusions of brick rubble  $\leq 0.04\text{m}$  (l) x  $\leq 0.03\text{m}$  (w), mortar and chalk lump (figure 31).

**Phase 2 group two** consists of four drains F(6), F(100), F(101), F(102). Drain F(6) lay horizontal to the posts pads F(7), F(9) and F(10) and is possibly connected to the kiln structure (figure 67). Drain F(100) = F(101) = F(102) was located at the southern end of the brick foundations in Area A.

Drain F(6) measured was  $\leq 1.0\text{m}$  (l) x  $\leq 0.15\text{m}$  (w) viewed in situ, was of N-S orientation and rectangular. The drain was made of hard fired red clay. The base segment measured  $\leq 0.30\text{m}$  (l) x  $\leq 0.16\text{m}$  (w) x  $\leq 0.09\text{m}$  (d). (figure 60),

Drain F(100) = F(101) = F(102) was constructed with bricks the drain was covered with flag tiles (figure 38, 64). The drain tiles measured  $\leq 0.22\text{m}$  (l) x  $\leq 0.22\text{m}$  (w) x  $\leq 0.5\text{m}$  (d) and  $\leq 0.15\text{m}$  (l) x  $\leq 0.15\text{m}$  (w) x  $\leq 0.4\text{m}$  (d) respectively and were made of hard fired red clay with flint and chalk inclusions.



**Phase 2 group three** consists of wall remnants F(25), F(27), F(28), F(29), F(30), F(93), F(95), F(96), F(97), F(99), F(160) and F(161) (figures 5, 6, 67 and 68).

The external walls consisted of F(25), F(27), F(28), F(29), F(30), F(160) and F(161). The brick foundations represented are outlined on the OS Maps of 1878, 1898, 1911, and 1921 (figures 2-5), and measured  $\leq 3.5\text{m}$  (l) x  $\leq 4.3\text{m}$  (w) x  $\leq 0.50\text{m}$  (d). The brick footings consisted of bricks with the makers mark H and measured  $\leq 0.22\text{m}$  (l) x  $\leq 0.11\text{m}$  (w) x  $\leq 0.06\text{m}$  (d) (figure 65).

The internal walls consisted of F(93), F(95), F(96) and F(97). The walls were all similar in dimension, measured  $\leq 3.5\text{m}$  (l) x  $\leq 0.30\text{m}$  (w) x  $\leq 0.50\text{m}$  (d), apart from F(96) where the length was  $\leq 2.2\text{m}$ . All were built of single skin walling. Only six courses remained including footings (figure 84).

### 2.3 Phase three 1911 Brickworks

This phase represents the period of brickwork operation as depicted on the OS maps of 1911 within Area A (figure 5). The archaeological activity on the site consists of one layer and three drains.

Layer/deposit (92) is comprised of a hardpacked chalk lump. It overlies the natural clay and lies beneath modern demolition layer (1) and measured  $\leq 2.40\text{m}$  (w) x  $\leq 2.20\text{m}$  (d) (figure 67).

**Phase three group one** consists of three drains F(24), F(87) and F(88). Drains F(87) and F(88) form the same drain. From the OS map of 1911 it appears that the kiln moved south of its original location (figure 5). Drains F(24), F(87) and F(88) are located adjacent to the kiln on the East and West and possibly formed part of the kiln structure (figure 73).

Drain F(24) measured  $\leq 0.80\text{m}$  (l) x  $\leq 0.15\text{m}$  (w), N-S orientation and linear in shape. The drain was made of hard fired red clay with chalk inclusions.

Drains F(87) and F(88) measured  $\leq 1.75\text{m}$  (l) x  $\leq 0.15\text{m}$  (w) and  $\leq 0.90\text{m}$  (l) x  $\leq 0.15\text{m}$  (w), orientated N-S and linear in shape. The drain F(87) was made of hard fired red clay and measured  $\leq 0.29\text{m}$  (l) x  $\leq 0.16\text{m}$  (w) x  $\leq 0.09\text{m}$  (d) with frequent flecks of chalk, occasional small fragments of flint  $\leq 0.025\text{m}$  (l) x  $\leq 0.01\text{m}$  (w) and small stones, (figure 62).

### 2.4 Phase four 1911 Mill Corner Farm

This phase represents the period from the demise of the brickworks as an operation to the use of the land for agricultural purpose as according to the OS map of 1911 Mill Corner Farm had now been built (figure 5, 74). The archaeological activity revealed on Area B Mill Corner Farm consisted of twelve layers, three linears, and two postholes (figure 74).

Layer (32) is the same as (77) is comprised of a hardpacked chalk lump. It overlies the natural clay and measured  $992\text{ m}^2$ .

Layer (58) is comprised of a hardpacked chalk lump and located within the internal brick foundations F(54) and F(68) of Mill Corner Farm, it is possible that it forms part of the internal flooring of the building. It overlies the natural and lies beneath layer (59) and measured  $\leq 8.0\text{m}$  (l) x  $\leq 4.2\text{m}$  (w). No dateable material was recovered.

Layer (59) is comprised of a compact mortar/concrete, with occasional chalk flecks and stones  $\leq 0.02\text{m}$  (l) x  $\leq 0.015\text{m}$  (w) and located within the internal brick foundations F(54) and F(58) of Mill Corner Farm and it is possible that it forms the upper surface of the internal flooring of the building. It overlies layer (58) and measured  $\leq 1.7\text{m}$  (l) x  $\leq 0.8\text{m}$  (w).

Layer (69) is comprised of a hardpacked chalk lump and located within the internal brick foundations F(56) and F(68) of Mill Corner Farm and it is possible that it forms the lower surface of the internal flooring of the building. It overlies the natural and lies beneath layer (70) and measured  $\leq 1.3\text{m}$  (l) x  $\leq 1.0\text{m}$  (w). No dateable material was recovered.

Layer (70) is comprised of a compact mortar/concrete, with occasional chalk flecks and stones  $\leq 0.02\text{m}$  (l) x  $\leq 0.015\text{m}$  (w) and located within the internal brick foundations F(56) and F(88) of Mill Corner Farm and it is possible that it forms the upper surface of the internal flooring of the building. It overlies layer (69) and measured  $\leq 0.3\text{m}$  (l) x  $\leq 0.2\text{m}$  (w). No dateable material was recovered.

Layers (71), (74) and (75) are comprised of a hardpacked chalk lump, and located within internal wall (56) of Mill Corner Farm and it is possible that the three layers form the lower surface of the internal flooring of the building. The layers overlie the natural and lie beneath a layer of mortar/concrete flooring similar to (59), and measured: layer (71)  $\leq 2.0\text{m}$  (l) x  $\leq 4.1\text{m}$  (w); layer (74)  $\leq 2.3\text{m}$  (l) x  $\leq 2.1\text{m}$  (w); layer (75)  $\leq 3.4\text{m}$  (l) x  $\leq 2.4\text{m}$  (w). No dateable material was recovered.

Layer (76) is comprised of a rubble spread, made up of brick fragments from the demolition of Mill Corner Farm and located to the North of the farm on Area B. The layer overlies drains F(130), F(132) and F(136) and measured  $\leq 13.8\text{m}$  (l) x  $\leq 3.5\text{m}$  (w). No dateable material was recovered.

Layer (78) is comprised of a rubble spread, made up of brick fragments from the demolition of Mill Corner Farm and located to the East of the farm on Area B. The layer overlies the natural and measured  $\leq 16.5\text{m}$  (l) x  $\leq 3.0\text{m}$  (w). No dateable material was recovered.

Layer (110) is comprised of a rubble spread, made up of brick fragments from the demolition of Mill Corner Farm and located to the North East of the farm on Area B. The layer overlies the natural and measured  $\leq 1.0\text{m}$  (l) x  $\leq 0.8\text{m}$  (w). No dateable material was recovered.

Linear (42) is comprised of a hardpacked chalk lump, and located parallel to external wall F(54) and F(55). The layer overlies drain F(129) and measured  $\leq 24.6\text{m}$  (l) x  $\leq 1.0\text{m}$  (w). No dateable material was recovered.

Linear F(65) is comprised of a grey/black clay with burnt wood fragments, and located within the internal walls of F(54) and F(68). The layer overlies the natural and measured  $\leq 1.0\text{m}$  (l) and  $\leq 0.2\text{m}$  (w). No dateable material was recovered.

Linear F(67) is comprised of a grey silt clay, and located within the internal walls F(54) and F(68). The layer overlies the natural and lies beneath layer (58), and measured  $\leq 1.9\text{m}$  (l) and  $\leq 0.1\text{m}$  (w). No dateable material was recovered.

Post and packing F(156). Post and packing F(156) is located abutted to internal wall F(68) (figure 92, 93). Of burnt wood, the post measured  $\leq 0.5\text{m}$  (l) x  $\leq 0.5\text{m}$  (w).

**Phase four group one** consists of three drains F(121), F(129) and F(136)

Drain F(121) was located parallel to wall (53). The drain underlay chalk layer (77) and measured  $\leq 9.7\text{m}$  (l) x  $\leq 0.2\text{m}$  (w) x  $\leq 0.4\text{m}$  (d).

Drain F(129) was located parallel to external wall F(54) and F(55). The drain was made of buff hard fired clay and circular in diameter. It underlay chalk linear F(42) and was cut into the natural clay and measured  $\leq 24.6\text{m}$  (l) x  $\leq 0.2\text{m}$  (w).

Drain F(136) was located at right angles to external wall F(56). The drain was made of buff hard fired clay and circular in diameter. The drain underlay rubble spread (76), was cut into the natural clay and cut by investigation slot [134]. It measured  $\leq 1.45\text{m}$  (l) x  $\leq 0.20\text{m}$  (w). The individual drain sections measured  $\leq 0.30\text{m}$  (l) x  $\leq 0.15\text{m}$  dia x  $\leq 0.15\text{m}$  in thickness.

**Phase four group two** consists of external wall remnants F(53), F(54), F(55), F(56), F(57), F(68), and F(122), (figures 5, 6, 69)

The brick foundations represented are outlined on the OS Maps of 1911, and 1921 (figures 5, 6), and measured; F(53)  $\leq 24.1\text{m}$  (l) x  $\leq 3.8\text{m}$  (w); F(68)  $\leq 24.8\text{m}$  (l) x  $\leq 5.0\text{m}$  (w); F(56)  $\leq 17.8\text{m}$  (l) x  $\leq 3.9\text{m}$  (w). The brick courses consisted of bricks made of red hard fired clay, which measured  $\leq 0.23\text{m}$  (l) x  $\leq 0.11\text{m}$  (w) x  $\leq 0.065\text{m}$  (d).

The internal walls consisted of F(93), F(95), F(96) and F(97). The wall were all similar in dimension, measured  $\leq 3.5\text{m}$  (l) x  $\leq 0.30\text{m}$  (w) x  $\leq 0.50\text{m}$  (d), apart from F(96) where the length was  $\leq 2.2\text{m}$ . All were built of single skin walling. Only six courses remained including footings (figure 84).

**Phase four group three** consists of three post holes F(60), [61] and F(62) possibly part of an internal wall construction, the group lies within the internal walls of Mill Corner Farm, orientated North / South.

The excavated post hole was that of [61]. The post hole was rectangular in shape and measured  $\leq 0.62\text{m}$  (l) x  $\leq 0.42\text{m}$  (w) x  $\leq 0.40\text{m}$  (d). A single fill (153) was present, consisting of a compact chalk lump. The post remnants of wood were square in shape, measuring  $\leq 0.14\text{m}$  (l) x  $\leq 0.14\text{m}$  (w) x  $\leq 0.25\text{m}$  (d) was present within post hole [61].

**Phase four group four** consists of two post holes F(63) and F(64) round in shape, possibly part of an internal wall construction, the group lies within the internal walls of Mill Corner Farm, orientated North / South and forms a line of post holes F(60) to F(62).

**Phase four group five** consists of five post holes [72], [73], F(107), F(108) and F(109) lying parallel to external wall F(56), of which [73], F(107), F(108) and F(109) were orientated East / West. It is possible the group of post holes formed part of the structure of the internal walls.

Post and packing [72], measured  $\leq 0.44\text{m}$  (w) x  $\leq 0.50\text{m}$  (d) in section. The primary fill/packing (148) was a light grey silt clay, with off white, compact chalk lump inclusions, occasional charcoal fragments and a few brick fragments and some fine rooting, and measured  $\leq 0.42\text{m}$  (w) x  $\leq 0.30\text{m}$  (d). A secondary fill (149) was a dark grey/black clay silt, with chalk lump inclusions and measured  $\leq 0.20\text{m}$  (w) x  $\leq 0.12\text{m}$  (d). The post remnants (152) measured  $\leq 0.20\text{m}$  (l) x  $\leq 0.10\text{m}$  (w) x  $\leq 0.36\text{m}$  (d), the post was wooden and burnt. The post (152) abutted the remnants of a possible

internal wall of mortar and brick fragments F(150), measuring  $\leq 0.18\text{m}$  (w) x  $\leq 0.22\text{m}$  (d), and brick F(151), and also abutted wall F(56) (figure 54).

The excavated post hole was that of [73]. The post hole [73] was rectangular in shape and measured  $\leq 0.30\text{m}$  (l) x  $\leq 0.40\text{m}$  (w) x  $\leq 0.34\text{m}$  (d). The primary fill (145) consisted of a light grey/brown silt clay, with frequent small chalk inclusions  $\leq 0.01\text{m}$  (l) x  $\leq 0.02\text{m}$  (w). The secondary fill (146) consisted of a light orangey/brown silt clay, with frequent small chalk inclusions  $\leq 0.01\text{m}$  (l) x  $\leq 0.02\text{m}$  (w), occasional brick fragments  $\leq 0.01\text{m}$  (l) x  $\leq 0.02\text{m}$  (w), and fine roots. The post remnants (147) were of wood and burnt, and measured  $\leq 0.10\text{m}$  (l) x  $\leq 0.10\text{m}$  (w) x  $\leq 0.10\text{m}$  (d) (figure 56, 103).

## 2.5 Phase five 1921 Brickworks

The period 1921 as recorded on the OS map of 1921, shows the expansion of Mill Corner Farm, with the Brickworks and kiln no longer denoted on the map (figure 6). The archaeology recovered from this period within Area A includes four drains, five post holes and three sections of wall.

**Phase five group one** consists of four drains, F(4), F(5), F(82) and F(106) located to the East of the brick foundations (figure 75).

Drain F(4) was made of hard fired red clay with chalk inclusions and measured  $\leq 2.50\text{m}$  (l) x  $\leq 0.10\text{m}$  (w), it was of N-S orientation and circular in diameter.

Drain F(5) was made of hard fired red clay and measured  $\leq 1.65\text{m}$  (l) x  $\leq 0.10\text{m}$  (w), it was of N-S orientation and circular in diameter. The drain was cut by a modern pit F(162).

Drain F(82) was made of hard fired red clay and measured  $\leq 3.90\text{m}$  (l) x  $\leq 0.10\text{m}$  (w), N-S orientation and circular in diameter.

Drain F(106) was made of hard fired red clay with chalk inclusions and measured  $\leq 6.10\text{m}$  (l) x  $\leq 0.15\text{m}$  (w), it was of N-S orientation and circular in diameter.

**Phase five group two** consists of five post holes F(18), F(19), F(21), F(104), F(105) lying parallel to the external wall F(25) on a North / South alignment (figure 75).

The post holes F(18), F(19), F(21), F(104), F(105) consisted of a single post surrounded on all sides by bricks. The post holes measured  $\leq 0.15\text{m}$  (l) x  $\leq 0.10\text{m}$  (w) and were rectangular in shape. Only fragments of burnt wood remained of all posts.

**Phase five group three** consists of three sections of wall remnants F(20) and F(84), (figure 75).

The brick foundations represented are outlined on the OS Map of 1921 (figure 6), and measured; F(20)  $\leq 2.0\text{m}$  (l) x  $\leq 0.2\text{m}$  (w); F(84)  $\leq 0.9\text{m}$  (l) x  $\leq 0.2\text{m}$  (w) with total suggested length F(20) to F(84)  $\leq 10.1\text{m}$  (l) x  $0.20\text{m}$  (w). A single brick course remained.

## 2.6 Phase six 1921 Mill Corner Farm

The period 1921 as recorded on the OS map of 1921, shows the expansion of Mill Corner Farm, with the Brickworks and kiln no longer denoted on the map (figure 6). The archaeology revealed from this period within Area B includes one layer, one post

a circular feature, three possible pits, twenty three post holes, two linears and, four drains and three sections of wall remnants (figure 76).

Layer (33) = (1) is comprised of a rubble spread, made up of brick fragments from the demolition of Mill Corner Farm. The layer overlay the archaeology of Area B and measured  $\leq 33.0\text{m}$  (l) East / West x  $\leq 29\text{m}$  (w) North / West.

Post F(66) was located to the south of external wall F(53) and measured  $\leq 0.10\text{m}$  (l) x  $\leq 0.15\text{m}$  (w).

Circular feature F(128) is filled with a hardpack chalk lump and was located to the south of drain F(121). It measured  $\leq 0.5\text{m}$  x  $\leq 0.5\text{m}$  in diameter.

**Phase six group one** consists of a group of three post holes F(34), [35] and F(36), that appear to reflect the remnants of a posted outbuilding attached to Mill Corner Farm,. The posts run in a line at right angles to the main farm buildings, orientated East / West. The outline is evident on the Ordnance Survey map of 1921 (figure 6)

The excavated post hole was that of [35]. The post hole was subcircular in shape and measured  $\leq 0.70\text{m}$  (l) x  $\leq 0.50$  (w) x  $\leq 0.26\text{m}$  (d). The primary fill (137) for posthole [35] was a compact, buff/yellow clay with occasional chalk inclusions, with a secondary fill (138) of a light grey clay silt with occasional chalk inclusions and subangular stones  $\leq 0.03\text{m}$  (l) x  $\leq 0.02\text{m}$  (w). The base of a burnt wooden post (139) survived within the post hole, and measured  $\leq 0.50\text{m}$  (l) x  $\leq 0.20\text{m}$  (w). The wooden post remnants were roughly rectangular in shape.

**Phase six group two** consists of a group of three possible pits F(37), F(39), [47] lying externally, parallel and west of Mill Corner Farm brick foundations, orientated North / South. No post remnants were evident.

The excavated possible possible pit was that of [47]. The pit was subcircular in shape and measured  $\leq 0.66\text{m}$  (l) x  $\leq 0.50\text{m}$  (w) and  $\leq 0.70\text{m}$  (d). A single fill (140) was present, a firm light grey clay silt, with the occasional nodular flint  $\leq 0.05\text{m}$  (l) x  $\leq 0.04\text{m}$  (w) and frequent chalk inclusions, a few brick fragments were present possible residual from building demolition.

**Phase six group three** consists of a group of six post holes F(38), F(40), F(43), F(44), [45], F(46), F(48) lying externally, parallel and west of Mill Corner Farm brick foundations, orientated North / South.

The excavated post hole was that of [45]. The post hole was circular in shape and measured  $\leq 0.57\text{m}$  (l) x  $\leq 0.60\text{m}$  (w) x  $\leq 0.72$  (d). A single fill (157) was present, consisting of a solid/compact dark grey/black tarmac. A post, square in shape measuring  $\leq 0.14\text{m}$  (l) x  $\leq 0.14\text{m}$  (w) was present within post hole [45].

**Phase six group four** consists of a group of two linears F(41) and F(52). Linears F(41) and F(52) lie west of the external wall of Mill Corner Farm brick foundations.

Linear F(41) is comprised of a hardpacked chalk lump and measured  $\leq 4.0$  (l) x  $\leq 0.30$  (w) It was located at right angles to wall (54), and orientated North / South. The layer overlies drain F(12) and lies beneath modern overburden (31), and cut by posthole F(40). No dateable material was recovered.

Linear F(52) is comprised of a grey silt clay, and measured  $\leq 1.0\text{m}$  (l) x  $\leq 0.2\text{m}$  (w). It was located at right angles to wall F(54), orientated East / West, The layer overlies

linear F(42), lies beneath modern overburden (31). No dateable material was recovered.

**Phase six group five** consists of a group of five post holes F(112), F(113), F(116), F(118) and F(123). The post holes are located in the centre of the brick foundation complex of Mill Corner Farm.

The construction of this group of postholes is similar to those found in Area A parallel to brick foundations F(25). The postholes were square in shape and consisted of a burnt wooden post surrounded by bricks and measured  $\leq 0.40\text{m}$  (l) x  $\leq 0.40\text{m}$  (w) with a  $\leq 0.10\text{m}$  (l) x  $\leq 0.10\text{m}$  (w) post.

Artefacts recovered consisted of small drain fragments found in the centre of posthole F(112).

**Phase six group six** consists of a group of two post holes F(114) F(115) located in the centre of the Mill Corner Farm complex.

The post holes F(114) and F(115) were rectangular in shape and measured  $\leq 0.30\text{m}$  (l) x  $\leq 0.30\text{m}$  (w), with a wooden post which measured  $\leq 0.15\text{m}$  (l) x  $\leq 0.10\text{m}$  (w).

**Phase six group seven** consists of two possible post holes [119], F(120) lying parallel to wall remnants F(122) and on an East / West alignment.

The excavated possible post hole was that of [119]. The posthole [119] was circular in shape and measured  $\leq 0.58\text{m}$  (w) x  $\leq 0.54\text{m}$  (w) x  $\leq 0.30\text{m}$  (d). A single fill (144) was present consisting of a compact chalk lump and measured  $\leq 0.58\text{m}$  (w) x  $\leq 0.54\text{m}$  (w) x  $\leq 0.30\text{m}$  (d).

**Phase six group eight** consists of a group of four post holes F(124), F(125), F(126) and [127], lie parallel to brick foundations F(53), between drain F(121) on the north and brick foundations on the south F(53), and East West orientation.

The excavated post hole was that of [127]. The post hole [127] was circular in shape and measured  $\leq 0.54\text{m}$  (l) x  $\leq 0.54\text{m}$  (w) x  $\leq 0.15\text{m}$  (d). The post remnants were of wood (143) and measured  $\leq 0.10\text{m}$  (l) x  $\leq 0.10\text{m}$  (w) x  $\leq 0.44\text{m}$  (d). The primary fill (142) consisted of compact chalk lump and measured  $\leq 0.20\text{m}$  (w) x  $\leq 0.10\text{m}$  (d). The secondary fill (141) consisted of a light grey brown clay silt, with occasional chalk inclusions  $\leq 0.01\text{m}$  (l) x  $\leq 0.02\text{m}$  (w) and brick fragments  $\leq 0.01\text{m}$  (l) x  $\leq 0.02\text{m}$  (w),

**Phase six group nine** consists of a group of four drains F(103), F(130), F(132) and F(136). Drains F(130), F(132) and F(136) were located at the northern end of Area B. Drain F(103) was located in the South / West corner of Area A on a North / South alignment. Drains F(130) and F(132) lay parallel to the pond. Drain F(136) lay at right angles to the pond into which it drained.

Drain F(103) was comprised of buff hard fired clay with chalk inclusions and measured  $\leq 0.80\text{m}$  (l) x  $\leq 0.20\text{m}$  (w), it was of North / South orientation.

Drain F(130) was comprised of buff hard fired clay with chalk inclusions surrounded by chalk lump and measured  $\leq 13.0\text{m}$  (l) x  $\leq 0.20\text{m}$  (w) and East/West orientation.

Drain F(132) was comprised of buff hard fired clay with chalk inclusions, surrounded by a light grey clay silt with inclusions of chalk lump and small flints, and measured  $\leq 6.2\text{m}$  (l) x  $\leq 0.2\text{m}$  (w), and North/South orientation.

Drain F(136) was comprised of buff hard fired clay with chalk inclusions, surrounded by a light orangey brown clay silt, and measured  $\leq 6.2\text{m}$  (l) x  $\leq 0.2\text{m}$  (w), and North/South orientation. Drain cut [163] was cut by slot [134] and capped with slate at the southern end. (figures 57, 58, 63).

**Phase six group ten** consists of a group of three sections of wall remnants F(49), F(50), F(51), located at the southern end of Area B on an alignment with brick foundations F(53).

Wall remnants F(49) was comprised of six bricks laid lengthways and side on, and measured in total  $\leq 0.60\text{m}$  (l) x  $\leq 0.22\text{m}$  (w), orientated East / West.

Wall remnants F(50) was comprised of two brick laid lengthways and side on, and measured in total  $\leq 0.20\text{m}$  (l) x  $\leq 0.22\text{m}$  (w), orientated East / West.

Wall remnants F(51) was comprised of one brick laid lengthways and side on, and measured  $\leq 0.10\text{m}$  (l) x  $\leq 0.22\text{m}$  (w). Remnants of mortar also remained beneath the brick and extended to  $\leq 1.0\text{m}$  (l) x  $\leq 0.22\text{m}$  (w), orientated East / West.

## 2.7 Phase seven 1975 Agricultural/industrial buildings

The period 1975 as recorded on OS map, shows the demise of Mill Corner Farm of 1921, with little remaining of the farm buildings on Areas A and B (figure 7). The archaeological activity from this period revealed, a linear, a posthole and one drain.

Linear F(79) consists of a line of five bricks, which measured  $\leq 1.9\text{m}$  (l) x  $\leq 0.10\text{m}$  (w) and lay within Area B, south of brick foundations F(53) on a North / South orientation and cut by post hole F(80).

Post hole F(80) was circular in shape and measured  $\leq 0.10\text{m}$  (l) x  $\leq 0.10\text{m}$  (w), and located within Area B, south of brick foundations F(53) and cut linear F(79).

Drain F(98) lies within Area A at the southern end of brick foundations F(25), F(30) F(160) and F(161). The drain was  $\leq 3.0\text{m}$  (l) and  $\leq 0.25\text{m}$  (w), it cut brick foundations F(25), F(99) F(160) and drain F(101) (figures 36, 37, 77, 84, 86).

## 2.8 Phase eight Post 1975 activity

Post 1975 activity has been denoted as any feature associated with the late 20<sup>th</sup> century demolition of Mill Corner Farm in lieu of the development. The archaeological activity consisted of seven layers of which six were located in Area A and one located in Area B, one pit, four investigation slots, one drain, a linear and two modern pits.

Layer (1) is comprised of building fragments from the demolition of Mill Corner Farm and located on Area A at the north of the site. The layer overlies all preserved archaeology and measured a total of  $1070\text{m}^2$ , to a maximum depth of  $\leq 0.50\text{m}$  (d) (figure 82).

Layer (3) is comprised of topsoil, and formed the northern boundary to Area A. It measured  $\leq 23.0\text{m}$  (l) x  $\leq 8.0\text{m}$  (w).

Layer (31) is comprised of building fragments from the demolition of Mill Corner Farm and located on Area B at the north of the site. The layer overlies all preserved archaeology, and measured a total of  $992\text{m}^2$ .

Layer (83) is comprised of a brick rubble spread and lies parallel to drain F(82). It measured  $\leq 1.8\text{m}$  (l) x  $\leq 1.0\text{m}$  (w).

Layer (85) is comprised of a brick rubble spread. The layer overlies drain F(82) and abuts wall F(84) and measured  $\leq 2.0$  (l) x  $\leq 1.2$  (w).

Layer (89) is comprised of a brick rubble spread, rectangular in shape and measured  $\leq 0.7\text{m}$  (l) x  $\leq 0.2\text{m}$  (w). It is located to the East of drain F(82), within Area A.

Layer (91) is comprised of a brick rubble spread and measured  $\leq 1.0\text{m}$  (l) and  $\leq 1.0\text{m}$  (w). It is located to the south of investigation slot F(90) and circular deposit F(92) within Area A.

**Phase eight group one** consists of a group of four investigation slots F(81), F(90), F(117) and [134]. Investigation slots F(81) and F(90) were located to the East of brick foundations F(25) within Area A. Investigation slots F(117) and [134] were located to the north of brick foundations F(53) and F(134) to the north of brick foundations F(56) within Area B.

Investigation slot F(81) was comprised of chalk lump and measured  $\leq 2.2\text{m}$  (l) x  $\leq 0.7\text{m}$  (w).

Investigation F(90) was comprised of chalk lump and measured  $\leq 2.6\text{m}$  (l) x  $\leq 0.6\text{m}$  (w).

Investigation slot F(117) was comprised of a sandy clay with inclusions of chalk lump, brick fragments, wood fragments and small fine roots. It measured  $\leq 2.7\text{m}$  (l) x  $\leq 0.9\text{m}$  (w).

Investigation slot [134] was comprised of a light-mid grey silt clay with inclusions of chalk lump, small stones and flints. It measured  $\leq 1.0\text{m}$  (l) x  $\leq 0.5\text{m}$  (w), and cut drain cut [163].

**Phase eight group two** consists of a drain F(22) and Flinear (23). The drain was located on the southern half of Area A. Linear F(23) also located on the southern half of Area A.

Drain F(22) was comprised of asbestos and measured  $\leq 17.0\text{m}$  (l) x  $\leq 0.70\text{m}$  (w), it was cut by an active water pipe within linear F(23), modern hardstanding/roadway, and also drain cut [106] and brick foundations F(25).

Linear F(23) was comprised of an active water pipe and measured  $\leq 7.3\text{m}$  (l) x  $\leq 0.40\text{m}$  (w). The water pipe measured  $\leq 0.6\text{m}$  in diameter.

**Phase eight group three** consists of two modern pits F(26) and F(162), located on the northern half of Area A.

Pit F(26) was comprised of Asbestos and measured  $\leq 2.3\text{m}$  (l) x  $\leq 0.8\text{m}$  (w). It abuts brick outcrop F(27) and is located to the East of brick foundations F(25).

Pit F(162) was comprised of brick rubble and concrete fragments, measured  $\leq 2.5\text{m}$  (l) x  $\leq 2.0\text{m}$  (w) and drain cut F(5), located to the East of brick foundations F(25).



**2.9 Phase nine Undated** consists of a group of four postholes, a tree bole and layer.

**Phase nine group one** is comprised of postholes F(13), F(14), F(15) and F(16). The postholes were located to the East of Area A along with layer (155).

Post hole F(13) measured  $\leq 0.10\text{m}$  (w) x  $\leq 0.10\text{m}$  (l) and square in shape, filled by a grey/black clay silt with wood fragments.

Post hole F(14) measured  $\leq 0.10\text{m}$  (w) x  $\leq 0.10\text{m}$  (l) and square in shape, filled by a grey/black clay silt with wood fragments.

Post hole F(15) measured  $\leq 0.10\text{m}$  (l) x  $\leq 0.10\text{m}$  (w) and square in shape, filled by a grey/black clay silt with wood fragments.

Tree bole F(111) was of irregular shape and measured  $\leq 1.8\text{m}$  (l) x  $\leq 1.0\text{m}$  (w). The tree bole F(111) was located to the East of Area B.

Layer (155) comprised of a grey silt clay and measured  $\leq 8.0\text{m}$  (l) x  $\leq 0.5\text{m}$  (d). It lies beneath layer (1) and overlies the natural.

### **3.0 Metal Detectorist Survey**

The stripped Areas A and B, features and spoil heaps were scanned by an experienced metal detectorist, see overview of finds (Appendix 9).

### **4.0 Conclusions**

In conclusion the strip, map and record achieved the aims and objectives as required by the Hertfordshire Historic Environment Team.

The strip, map and record was appropriate to the nature of the development. Weather conditions were generally favourable, but episodes of inclement weather, caused difficult working conditions due to the nature of the natural clay.

The archaeological resource in quantity and extent was quantified through detailed recording of a sample of the features in both areas A and B over the 0.20ha area of the PDA. From the information recovered it was possible to date, identify and define the purpose of the archaeological deposits found through historic documentation and specialist knowledge, together with its likely extent, localized depth and quality of preservation.

The results of the investigation revealed and supported the archaeological remains of some value and significance present on the site, dating from the mid 19th century to early 20th century. These were in two areas A and B and represented a 19th century Brickworks as documented on the Ordnance Survey map of 1878 (figure 3) and 20<sup>th</sup> century Mill Corner Farm as referenced on the Ordnance Survey map of 1911 (figure 5).

The archaeology found at the Farmyard, Brickyard Lane in furtherance to the evaluation extends the archaeological and historical knowledge of its use and activity during antiquity that has already been recorded, as far as; the presence of 19th century land drainage over Areas A and B provided evidence for activity on the land whether for agricultural or industrial use; prior to 1878 documentation shows the land dearth of buildings and possibly under agricultural use (OS map 1862, Waring 2014);

evidence for Brickwork activity dating from the mid 1800s (Doig, 2016) and shown on a series of Ordnance Survey maps (figures 3 to 6) and according to the OS map of 1878 and 1898 the Brickworks kiln lay on the northern boundary of the PDA with an access road, which by 1911 (OS map figure 5) is no longer clearly evident. Dating the demise of the Brickworks as early 20th century has been tentatively possible as the remains are not evident cartographically after 1921.

From the archaeology discovered during the strip, map and record on the PDA, it has also been possible to further elaborate on the industrial and agricultural development of the village of Reed. A contribution has been made to the industrial development of the site with the discovery of the remains of the Brickworks. The remnants discovered in Areas A and B provide evidence for the development of Reed as a village and potentially reflecting an increase in population at that time with the need for bricks. Closure of the brickworks is recorded as 1909 when Mr Andrews the brickmaker retired (Appendix 4). From 1911 onwards (figure 5) farm buildings on the PDA increase as noted with the comparison of the Ordnance Survey maps of 1878 and 1898 (figures 3 and 4). By 1975 (figure 7 OS map) the thatched cottages with attached drying shed (Appendix 4) have been demolished, reflecting the transition from brickmaking to agriculture. An enhanced understanding of the development of the village of Reed, has therefore been gained from both documentary and archaeological evidence for the existence and extent of the Brickworks and Mill Corner Farm.

Overall, the PDA has revealed archaeological evidence for use and activity from the late 19th century in the form of the Brickworks and from early 20th century with the introduction of buildings belonging to Mill Corner Farm.

**SUPPORTING ILLUSTRATIONS**

**APPENDIX 1: Areas A and B**

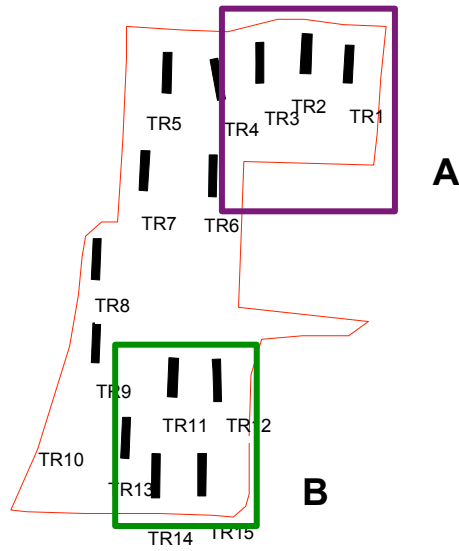

Figure 1 Areas of archaeological significance Brickworks (A) and Early 19<sup>th</sup> century Farm Buildings (B)

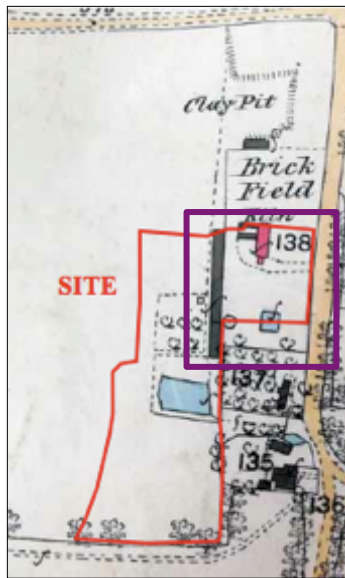

Figure 2 OS map of 1878

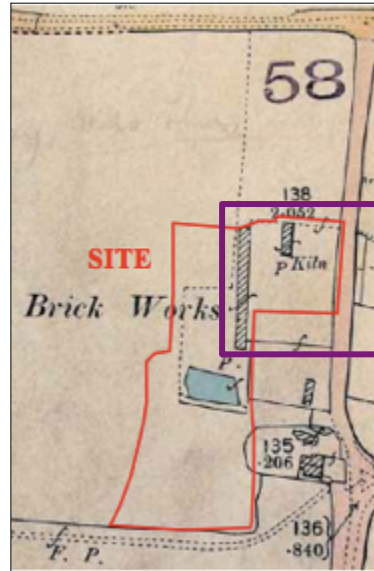

Figure 3 OS map of 1898

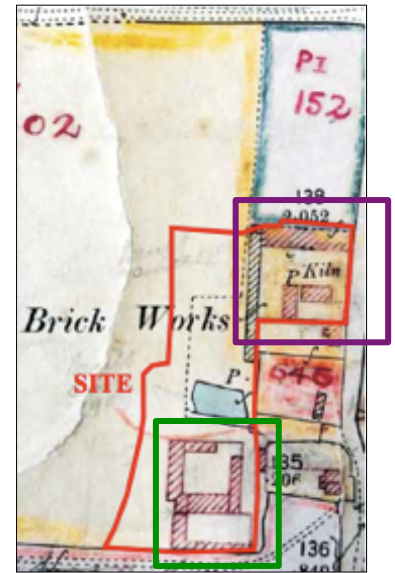

Figure 4 OS map of 1911

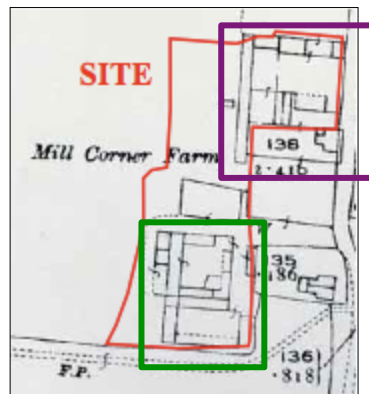

Figure 5 OS map of 1921

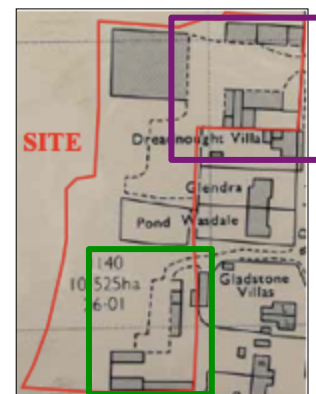

Figure 6 OS map of 1975

## APPENDIX 2: Site photographs

### Area A Plan views



Figure 7: North facing view of brick foundations



Figure 8: South facing view of brick foundations



Figure 9: South East facing view of brick foundations and 1911 kiln location



Figure 10: East facing view of brick foundations



Figure 11: East facing view of brick foundations



Figure 12: North East facing view of brick foundations

## Area B Plan views



Figure 13: West facing view of Mill Corner Farm 1 of 3



Figure 14: West facing view of Mill Corner Farm 2 of 3



Figure 15: West facing view of Mill Corner Farm 3 of 3



Figure 16: South facing view of Mill Corner Farm 1 of 4



Figure 17: South facing view of Mill Corner  
Farm 2 of 4



Figure 18: South facing view of Mill Corner Farm 3 of 4



Figure 19: South facing view of Mill Corner  
Farm 4 of 4



Figure 20: South East facing view of Mill Corner Farm 1 of 4



Figure 21: South East facing view of Mill Corner Farm  
2 of 2



Figure 23: North facing view of Mill Corner Farm 1 of 2



Figure 24 North facing view of Mill Corner

Farm 2 of 2



Figure 25: East facing view of Mill Corner Farm 1 of 4



Figure 26: East facing view of Mill  
Corner Farm 2 of 4



Figure 27: East facing view of Mill Corner Farm 3 of 4



Figure 28: East facing view of Mill  
Corner Farm 4 of 4



## Area A Section and feature views



Figure 29: North facing view of section no 4



Figure 30: South facing view of drain F(4), F(5), F(6) and brick pad F(8) locations



Figure 31: Plan view of brick pad F(8)



Figure 32: Plan view of drain F(4)



Figure 33: Plan view of drain F(5)



Figure 34: North facing view of drain F(87), F(88) F(88)



Figure 35: Plan view of drain F(87),



Figure 36: West facing view of wall F(25) and drain F(98) Figure 37: North facing view of drain F(98) and doorway F(99)



Figure 38: Plan view of drain construction F(101)

## Area B Section and feature views



Figure 39: West facing section of external wall F(55) wall F(68)



Figure 40: East facing section of external



Figure 41: West facing section of internal wall F(68) internal wall F(56)



Figure 42: South facing section of



Figure 43: North facing section of internal wall F(57) external F(56)



Figure 44: North facing section of wall



Figure 45: Posthole [35] location within Mill Corner Farm



Figure 46: Plan view of posthole [35]



Figure 47: Posthole/pit [47] location within Mill Corner Farm



Figure 48: Plan view of posthole/pit [47]



Figure 49: Plan view of post and packing [45]



Figure 50: Side view of post and



Figure 51: Posthole [127] location within Mill Corner Farm Figure 52: South facing view of posthole [127]



Figure 53: Post and packing [72], location within MCF [72]



Figure 54: South facing view of post



Figure 55: Post [72], location within MCF hole (127)



Figure 56: South facing view of post



Figure 57: Rectangular slot [134] and drain [136] location within MCF



[136]



Figure 58: South facing view of drain

Figure 59: South facing view of rectangular slot [134]

**Areas A and B Ceramic building material**



Figure 60: Drain base F(6)



Figure 61: Drain base F(24)



Figure 62: Drain F(87)



Figure: 63: Drain base F(136)



Figure 64: Drain tiles F(101)



Figure 65: Drain tile F(88)



Figure 66: Drain tile F(50)



### APPENDIX 3: Plans and sections

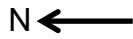

Figure 67: Plan view of Area A showing remnants of Brickworks, Thatched Cottages and Mill Corner Farm

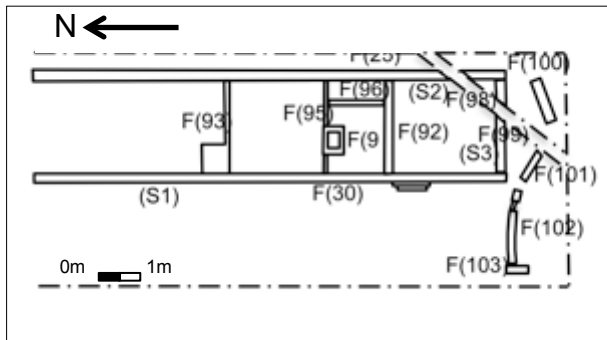

Figure 68: Plan view of Area A south end

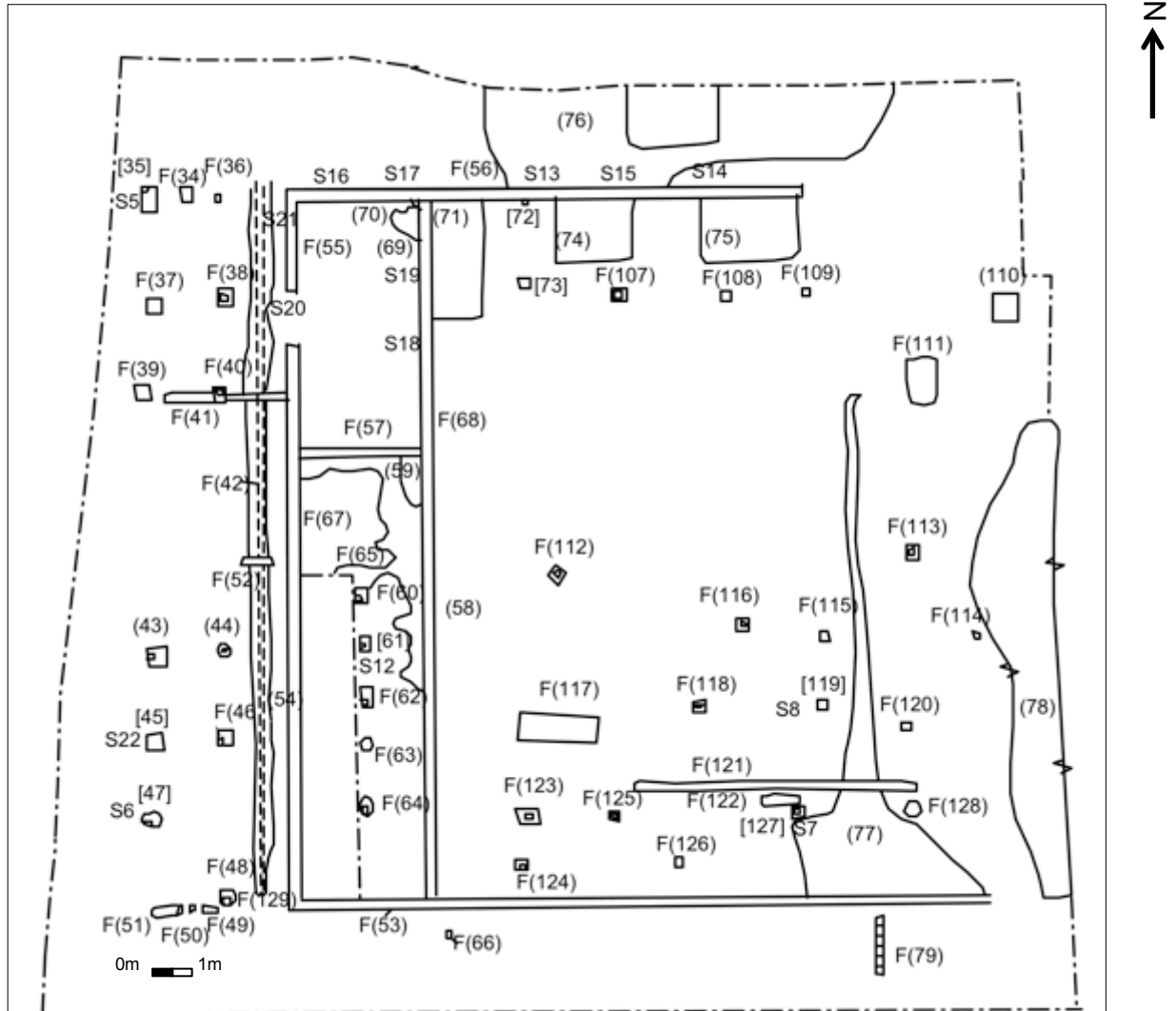

Figure 69: Plan view of Area B showing remnants of Mill Corner Farm

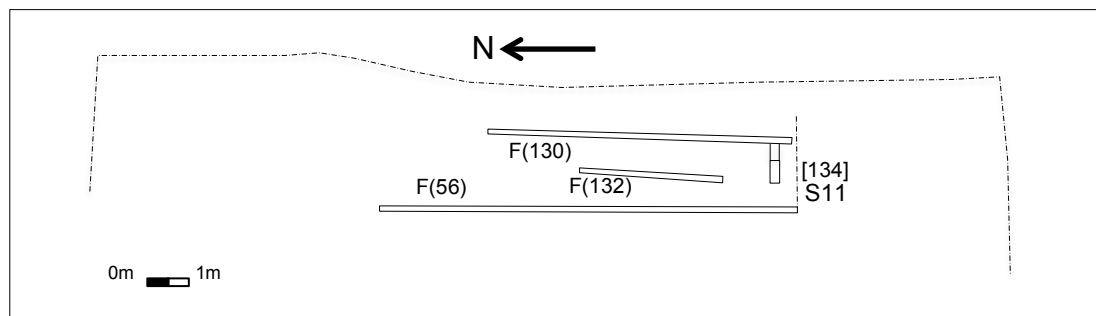

Figure 70: Plan view of Area B Mill Corner Farm, after removal of rubble layer (76)

**Area A and B Phase plans**

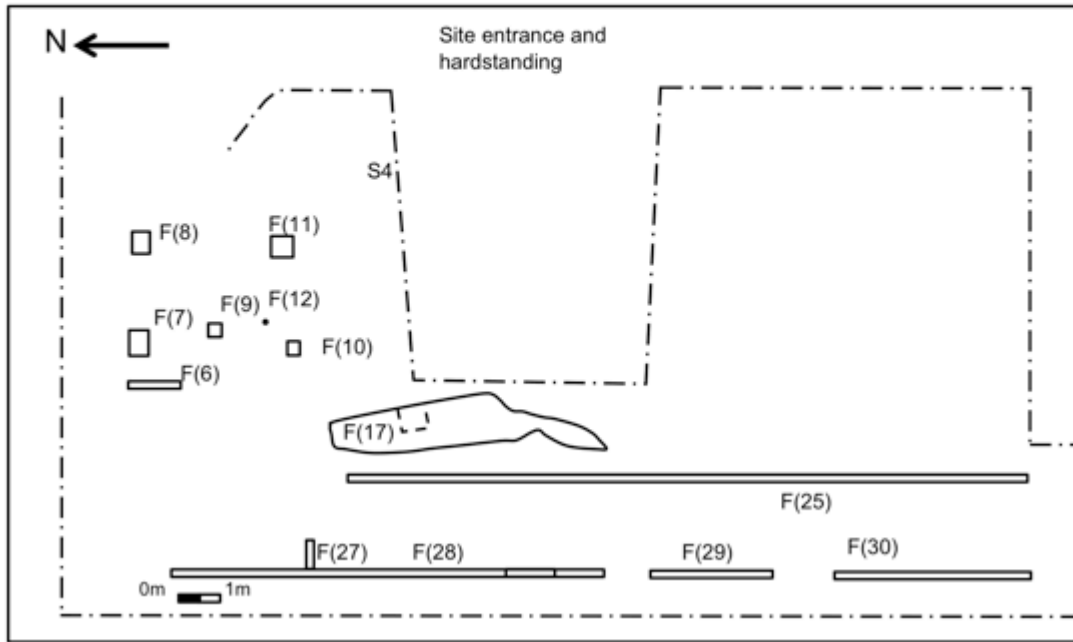

Figure 71: Phase two Area A 1878-1898 Brickworks

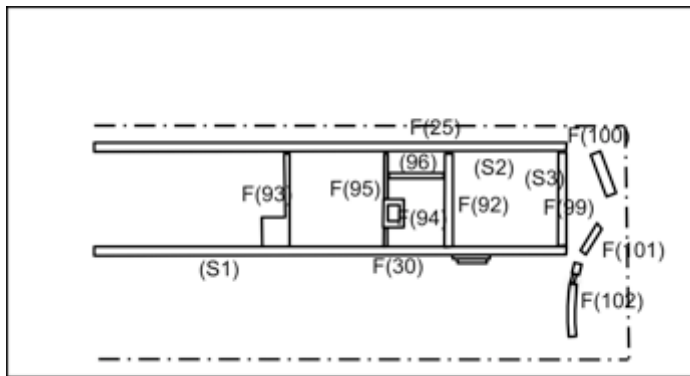

Figure 72: Phase two Area A 1878-1898 Brickworks - southern end

Figure 73: Phase three Area A 1911 Brickworks

Figure 74: Phase four Area B 1911 Mill Corner Farm

Figure 75: Phase five Area A 1921 Mill Corner Farm

Figure 76: Phase six Area B 1921 Mill Corner Farm

Figure 77: Phase seven Area A 1975 Mill Corner Farm

Figure 78: Phase seven Area B 1975 Mill Corner Farm

Figure 79: Phase eight Area A post 1975 activity

Figure 80: Phase eight Area B post 1975 activity





Figure 81: Phase nine: Area A undated activity

## Area A Plans and sections continued

Figure 82: North facing section no 4 of layers (1), (2) and (155)

Figure 83: West facing section no 1 of wall remnants F(30) southern end

Figure 84: West facing section no 2 of wall remnants F(25) and drain F(98)

Figure 85: West facing section no 2 showing brick construction of wall F(25) - 5 courses with footing

Figure 86: North facing section no 3 of drain F(98) and wall F(99)

Figure 87: North facing section no 3 showing brick construction of wall F(99) - 4 courses with footing

## Area B Plans and sections

Figure 88: North facing section no 13 of wall remnants F(56)

Figure 89: North facing section no 14 showing brick construction of wall F(56) - 2 courses with footing

Figure 90: North facing section no 15 showing brick construction of wall F(56) – 3 courses with footing

Figure 91: Plan view of north facing section no 15 showing brick construction of wall F(56)

Figure 92: West facing sections no 18 and 19 of wall remnants F(68)

Figure 93: West facing section no 19 showing brick construction of wall F(68) - 2 courses

Figure 94: Plan view of west facing section no 19 showing brick construction of wall F(68)

## Area B Plans and sections continued

Figure 95: West facing section no 20 of wall remnants F(54) and F(55)

Figure 96: West facing section no 21 showing brick construction of wall F(55) – 2 courses

Figure 97: Plan view of west facing section no 20 showing brick construction of wall F(55)

## Area B plans and sections continued

Figure 98: Plan view of post hole [35]

Figure 99: South facing view of post hole [35]

Figure 100: Plan view of post hole [47]

Figure 101: South facing view of post hole [47]

Figure 102: Plan view of post hole [73]

Figure 103: South facing view of post hole [73]

Figure 104: Plan view of post hole [119]  
[119]

Figure 105: South facing view of pit/post hole

Figure 106: Plan view of post hole [127]

Figure 107: South facing view of post hole [127]

Figure 108: Plan view of slot [134] and drain [163]

Figure 109: North facing view of slot [134]

## APPENDIX 4 Archive sources

Figure 110: Cockett & Nash Auctions – Lot 6 details

Figure 110: Archive sources (Doig, 2017)

## **APPENDIX 5: Archive qualification (Site Code: REEDBL15)**

**Recorded Contexts:** 164 contexts

**Digital Photographic Archive:** 257 photographs

**Drawn Plans Archive:** 3 x A3 sheets at 1:50

**Drawn Sections Archive:** 5 x A3 sheets at 1:10

**Level Diary** Yes

**GPS plot:** Leica 1200 GPS Smart Rover with RTK differential correction giving global positioning accuracy to within 2cm

### **FINDS**

**Small Finds:** None

**Bulk Finds:** CBM.

### **Environmental Samples:**

**Level Diary:** See GPS Data

## APPENDIX 6: Finds quantification

Feature No	No	Type	Weight (kg)	Date range
F6	1	CBM – drain tile	4.9	mid 19 <sup>th</sup> C
F4, F5	1	CBM - drains	0.01	19 <sup>th</sup> C
F24	1	CBM - drain	3.0	mid 19 <sup>th</sup> C
F30	1	CBM – brick with makers mark (H)	2.3	mid 19 <sup>th</sup> C
F55	1	CBM – brick with button shaped impressions	2.8	20 <sup>th</sup> C
F59	1	CBM – flooring frag	1.218	20 <sup>th</sup> C
F101	1	CBM – drain tile	4.0	mid 19 <sup>th</sup> C
F101	1	CBM – drain tile	1.3	mid 19 <sup>th</sup> C
F112	1	CBM - drain	0.04	20th C
F99, F160, F161	1	CBM – thin brick no frog	2.3	19 <sup>th</sup> C
F136	1	CBM - drain	3.567	20th C

## APPENDIX 7: Context summary

Phase Number	Group Numbers	Phase Description
1		Pre 1878 activity No dateable finds or features
2	1 2 3	1878-1898 Brickwork remnants Post pads F(7), F(8), F(9), F(10), F(11) and F(12) Drains F(6), F(100), F(101), F(102) Wall remnants F(25), F(27), F(28) F(29), F(30), F(93), F(95), F(96), F(97), F(99), F(160), F(161) Brickwork red clay deposit F(17) Flooring? F(94) Layer (2)
3	- 1	1911 Brickwork remnants Drain F(24), F(87), F(88) Layer (92)
4	- 1 2 3 4 5	1911 Area B Mill Corner Farm Drains F(121), F(129) and F(136) Wall remnants F(53), F(54), F(55), F(56), F(57), F(68), F(122) Post holes – internal square F(60), [61], F(62) Post holes – internal round F(63) and F(64) Post holes – external building remnants F(72), F(73), F(107), F(108), F(109) Layers (32) = (77), (58), (59), (69), (70), (71), (74), (75), (76), (77), (78), (110) Linears F(42), F(65), F(67) Posts F(156), F(159)
5	1 2 3	1921 Area A Mill Corner Farm Drains F(4), F(5), F(82) and F(106) Post holes F(18), F(19), F(21), F(104), F(105) Walls F(20), F(84), F(86)
6	1 2 3 4 5 6 7 8 9 10	1921 Area B Mill Corner Farm Post holes F(34), [35] and F(36) Post holes/Pits – external F(37), F(39), [47] Post holes – tarmac – external F(38), F(40), F(43), F(44), F(45), F(46), F(48) Linears F(41), F(52) Post holes external F(112), F(113), F(116), F(118), F(123) Post holes external F(114), F(115) Pits no post external F(119), F(120) Post holes external F(124) to F(127) Drains F(103), F(130), F(132), F(136) Wall remnants F(49), F(50), F(51) Post F(66) Circular feature F(128) Layer (33)
7		1975 Area A Agricultural/industrial buildings 1975 Area B Agricultural/industrial buildings Linear F(79) Drain F(98) Post hole F(80)
8	1 2	Post 1975 activity Areas A/B Investigation slot F(81), F(90), F(117), [134] Drains F(22), F(23)



	3	Pit F(26), F(162) Layer (1), (3), (31), (83), (85), (89), (91)
9	1	Undated Post holes F(13), F(14), F(15) and (F16) Tree bole F(111) Layer (155)

Ftr/Cxt No.	Area	Phase No	Group No	Description	Interpretation	Find
1	A	8		Post 1975 activity	Layer – overburden	
2	A	2		1878-1898 Brickworks	Layer - chalk – hard pack/road	
3	A	8		Post 1975 activity	Layer - headland – topsoil	
F4	A	5	1	1921 Mill Corner Farm	Drain – field drain – N/S	
F5	A	5	1	1921 Mill Corner Farm	Drain – field drain – N/S cut by pit F(162)	
F6	A	2	2	1878-1898 Brickworks	Drain – field drain – N/S	CBM
F7	A	2	1	1878-1898 Brickworks	Brick pad?	
F8	A	2	1	1878-1898 Brickworks	Brick pad?	
F9	A	2	1	1878-1898 Brickworks	Brick pad?	
F10	A	2	1	1878-1898 Brickworks	Brick pad?	
F11	A	2	1	1878-1898 Brickworks	Brick pad?	
F12	A	2	1	1878-1898 Brickworks	Brick pad?	
F13	A	9	1	undated	Part post still in situ	
F14	A	9	1	undated	Part post still in situ	
F15	A	9	1	undated	Small p/h / tree bowl?	
F16	A	9	1	undated	Burnt out post	
F17	A	2		1878 - 1898 Brickworks	Red clay silt deposit	
F18	A	5	2	1921 Mill Corner Farm	Brick surround – square post	
F19	A	5	2	1921 Mill Corner Farm	Brick surround – square post	
F20	A	5	3	1921 Mill Corner Farm	Wall E-W same as walls F(84) and F(86)	
F21	A	5	2	1921 Mill Corner Farm	Brick surround - square post	
F22	A	8	2	Post 1975 activity	Drain N/E – S/W asbestos filled cuts wall F(25), drainFs (24) and F(106), cut by linear F(23)	
F23	A	8	2	Post 1975 activity	Linear containing water pipe, cuts drain F(22), walls F(25) and F(30)	
F24	A	3	1	1911 Brickworks	Drain N/S cut by drain F(22)	CBM
F25	A	2	3	1878-1898 Brickworks	Wall remnants cut by drains F(22), F(98) and linear F(23)	
F26	A	8		Post 1975 activity	Modern pit asbestos filled	
F27	A	2	3	1878-1898 Brickworks	Brick outcrop – internal wall	
F28	A	2	3	1878-1898 Brickworks	Wall N-S	
F29	A	2	3	1878-1898 Brickworks	Wall N-S	
F30	A	2	3	1878-1898 Brickworks	Wall cut by drains F(22) and (F23)	CBM
31	B	8		Post 1975 activity	Layer – overburden Area B, (site strip (1)	
32	B	4		1911 Mill Corner Farm	Layer - Chalk – hard pack – roadway same as (77), (site strip (1)	
33	B	6		1921 Mill Corner Farm	Layer – brick rubble, site strip (1)	
F34	B	6	1	1921 Mill Corner Farm	Post hole with post	
[35]	B	6	1	1921 Mill Corner Farm	Post hole cut with post F(139) and filled by (137). (138)	
F36	B	6	1	1921 Mill Corner Farm	Post hole with post/nail	
F37	B	6	2	1921 Mill Corner Farm	Posthole / pit	
F38	B	6	3	1921 Mill Corner Farm	Post hole with post	
F39	B	6	2	1921 Mill Corner Farm	Post hole / pit	
F40	B	6	3	1921 Mill Corner Farm	Post hole cuts linear F(41)	
F41	B	6	4	1921 Mill Corner Farm	Linear E-W cuts layer (42)	
F42	B	4		1911 Mill Corner Farm	Chalk linear N/S cut by linear F(41) and F(52), overlies drain F(129)	
F43	B	6	3	1921 Mill Corner Farm	Square post hole with post	
F44	B	6	3	1921 Mill Corner Farm	Round post hole with post	
[45]	B	6	3	1921 Mill Corner Farm	Square post hole cut, filled by (157) and post (158)	
F46	B	6	3	1921 Mill Corner Farm	Square post hole with post	
[47]	B	6	2	1921 Mill Corner Farm	Round post hole cut filled by (140)	
F48	B	6	3	1921 Mill Corner Farm	Post hole	
F49	B	6	10	1921 Mill Corner Farm	Wall footing - single brick E-W	
F50	B	6	10	1921 Mill Corner Farm	Wall footings– single brick E-W	
F51	B	6	10	1921 Mill Corner Farm	Wall footings – single brick E-W	
F52	B	6	4	1921 Mill Corner Farm	Linear , cuts linear (42)	
F53	B	4	2	1911 Mill Corner Farm	Wall foundations E-W abuts walls F(54) and F(68)	
F54	B	4	2	1911 Mill Corner Farm	Wall foundations N-S abuts walls F(53), F(56) and F(57)	
F55	B	4	2	1911 Mill Corner Farm	Wall foundations N-S abuts walls F(53), F(56) and F(57), and layer (58)	CBM
F56	B	4	2	1911 Mill Corner Farm	Wall foundations E-W abuts walls F(55) and (F68) and layers (71), (74), (75) and (76)	
F57	B	4	2	1911 Mill Corner Farm	Internal wall foundations E-W abuts walls F(54) and F(68), and layers (58) and (59)	
58	B	4		1911 Mill Corner Farm	Layer – chalk underlies layer (59), same as (69)	
59	B	4		1911 Mill Corner Farm	Layer - mortar flooring overlies layer (58) same as (70)	CBM
F60	B	4	3	1921 Mill Corner Farm	Square post hole with stake, cuts layers (58) and (59)	

[61]	B	4	3	1921 Mill Corner Farm	Square post hole cut with stake (154), cuts layers (58) and (59)	
F62	B	4	3	1921 Mill Corner Farm	Square post hole with stake cuts layers (58) and (59)	
F63	B	4	4	1921 Mill Corner Farm	Round post hole with stake, cuts layers (58) and (59)	
F64	B	4	4	1921 Mill Corner Farm	Round post hole with stake, cuts layers (58) and (59)	
F65	B	4		1911 Mill Corner Farm	Linear, abuts layers (58)	
F66	B	6		1921 Mill Corner Farm	Post	
F67	B	4		1911 Mill Corner Farm	Linear, lies below layer (58)	
F68	B	4		1911 Mill Corner Farm	Wall N-S abuts walls F(53), F(56), F(57) and layers (58), (59), (69), (70) and (71)	
69	B	4		1911 Mill Corner Farm	Layer - chalk pack underlies layer (70) same as (58)	
70	B	4		1911 Mill Corner Farm	Layer - flooring overlies layer (69), same as (59)	
71	B	4		1911 Mill Corner Farm	Layer - chalk flooring abuts walls F(56) and F(68)	
[72]	B	4	5	1911 Mill Corner Farm	Posthole cut, filled by (148), (149), (150) post F(152) abuts wall F(56)	
[73]	B	4	5	1911 Mill Corner Farm	Posthole cut filled by (145), (146), post F(147), with brick post pad	
74	B	4		1911 Mill Corner Farm	Layer - chalk flooring abuts wall F(56)	
75	B	4		1911 Mill Corner Farm	Layer - chalk flooring abuts wall F(56)	
76	B	4		1911 Mill Corner Farm	Layer - rubble spread remains 1911 farm abuts wall F(56), overlies rectangular slot [134] and drain F(136)	
77	B	4		1911 Mill Corner Farm	Layer - chalk underlies demolition layer (31) and linear F(121)	
78	B	4		1911 Mill Corner Farm	Layer - rubble spread remains 1911 Farm - east side	
F79	B	7		1975 Farm buildings	Wall N-S nissan hut remnant? Cut by F(80)	
F80	B	7		1975 Farm buildings	Post hole, cuts F(79)	
F81	A	8	1	Post 1975 activity	Investigation slot	
F82	A	5	1	1921 Brickworks	Drain terracotta underlies rubble (85)	
83	A	8		Post 1975 activity	Layer - brick rubble spread	
F84	A	8		1921 Mill Corner Farm	Wall E-W abuts (85), same as walls F(20) and F(86)	
85	A	8		Post 1975 activity	Layer - brick rubble abuts (84)	
F86	A	8		1921 Mill Corner Farm	Wall E-W abuts drain F(87), same as walls F(20) and F(84)	
F87	A	3	1	1911 Brickworks	Drain - Terracotta same as F(88)	CBM
F88	A	3	1	1911 Brickworks	Drain - Terracotta same as F(87)	
F89	A	8		Post 1975 activity	Brick rubble spread	
F90	A	8	1	Post 1975 activity	Investigation slot	
91	A	8		Post 1975 activity	Layer - brick rubble spread	
92	A	3		1911 Brickwork	Layer - chalk flooring remnants	
F93	A	2	3	1878-1898 Brickworks	Inner separation wall	
F94	A	2		1878-1898 Brickworks	Rectangular brick formation - flooring?	
F95	A	2	3	1878-1898 Brickworks	Inner separation wall	
F96	A	2	3	1878-1898 Brickworks	Inner separation wall	
F97	A	2	3	1878-1898 Brickworks	Inner separation wall	
F98	A	7		1975 Agricultural/industrial buildings	Drain - terracotta cuts walls F(25), F(160), F(161) and drain F(101)	
F99	A	2		1878-1898 Brickworks	Doorway, cut by drain F(98), abuts wall F(161)	
F100	A	2	2	1878-1898 Brickworks	Flag tiles - terracotta	
F101	A	2	2	1878-1898 Brickworks	Brick drain - terracotta drain covering cut by drains F(98)	CBM
F102	A	2	2	1878-1898 Brickworks?	Flag tiles - terracotta drain covering cut by drain F(103)	
F103	A	6	9	1921 Mill Corner Farm	Drain cuts drain F(102)	
F104	A	5	2	1921 Mill Corner Farm	Post hole with brick surround	
F105	A	5	2	1921 Mill Corner Farm	Post hole with brick surround	
F106	A	5	1	1878-1898 Brickworks?	Drain, cut by drain F(22)	
F107	B	4	5	1911 Mill Corner Farm	Post hole	
F108	B	4	5	1911 Mill Corner Farm	Post hole with post	
F109	B	4	5	1911 Mill Corner Farm	Post hole	
110	B	4		1911 Mill Corner Farm	Layer - brick rubble spread	
F111	B	9		Undated	Tree bole	
F112	B	6	5	1921 Mill Corner Farm	Brick lined post hole	
F113	B	6	5	1921 Mill Corner Farm	Brick lined post hole	
F114	B	6	6	1921 Mill Corner Farm	Post hole	
F115	B	6	6	1921 Mill Corner Farm	Post hole	
F116	B	6	5	1921 Mill Corner Farm	Brick lined post hole	
F117	B	8	1	Post 1975 activity	Investigation slot	
F118	B	6	5	1921 Mill Corner Farm	Brick lined post hole	
[119]	B	6	7	1921 Mill Corner Farm	Cut of post hole/pit, filled by F(144)	
F120	B	6	7	1921 Mill Corner Farm	Post hole	
F121	B	4	1	1911 Mill Corner Farm	Field drain - terracotta, underlying layer (77)	
F122	B	4	2	1911 Mill Corner Farm	Wall remnants - brick rubble	
F123	B	6	5	1921 Mill Corner Farm	Brick lined post hole	
F124	B	6	8	1921 Mill Corner Farm	Post hole	
F125	B	6	8	1921 Mill Corner Farm	Post hole	
F126	B	6	8	1921 Mill Corner Farm	Post hole	
[127]	B	6	8	1921 Mill Corner Farm	Posthole cut filled by (141), (142), post F(143)	
F128	B	6		1921 Mill Corner Farm	Chalk filled circular feature	
F129	B	4	1	1911 Mill Corner Farm	Drain underlies linear F(42)	
[130]	B	6	9	1921 Mill Corner Farm	Drain	

(131)	B	6	9	1921 Mill Corner Farm	Fill of drain [130]	
[132]	B	6	9	1921 Mill Corner Farm	Drain	
(133)	B	6	9	1921 Mill Corner Farm	Fill of drain [132]	
[134]	B	8	1	Post 1975 activity	Rectangular slot filled by (135), underlies rubble spread (76)	
(135)	B	8	1	Post 1975 activity	Fill of rectangular slot [134]	
F136	B	6	9	1921 Mill Corner Farm	Drain - underlies rubble spread (76)	CBM
(137)	B	6	1	1921 Mill Corner Farm	Fill of post hole [35]	
(138)	B	6	1	1921 Mill Corner Farm	Fill of post hole [35]	
F139	B	6	1	1921 Mill Corner Farm	Post within cut [35]	
(140)	B	6	2	1921 Mill Corner Farm	Fill of post hole [47]	
(141)	B	6	8	1921 Mill Corner Farm	Fill of post hole [127]	
(142)	B	6	8	1921 Mill Corner Farm	Fill of post hole [127]	
F143	B	6	8	1921 Mill Corner Farm	Post within cut [127]	
(144)	B	6	5	1921 Mill Corner Farm	Fill of post hole [116]	
(145)	B	4	5	1921 Mill Corner Farm	Fill of post hole [73]	
(146)	B	4	5	1921 Mill Corner Farm	Fill of post hole [73]	
F147	B	4	5	1921 Mill Corner Farm	Post within cut [73]	
(148)	B	4	5	1921 Mill Corner Farm	Fill of post hole [72]	
(149)	B	4	5	1921 Mill Corner Farm	Fill of post hole [72]	
(150)	B	4	5	1921 Mill Corner Farm	Fill of post hole [72]	
(151)	B	4	5	1921 Mill Corner Farm	Masonry abutting post [72]	
F152	B	4	5	1921 Mill Corner Farm	Post within cut [72]	
(153)	B	4	3	1921 Mill Corner Farm	Fill of post hole [61]	
F154	B	4	3	1921 Mill Corner Farm	Post within cut [61]	
155	A	9		undated	Grey silt layer	
F156	B	4	5	1911 Mill Corner farm	Post abutting internal wall F(68)	
(157)	B	6	3	1921 Mill Corner Farm	Fill of post hole [45]	
F158	B	4	3	1921 Mill Corner Farm	Post within cut [61]	
F159	B	4	5	1911 Mill Corner Farm	Post? Within cut [73]	
F160	A	2	3	1878-1898 Mill Corner Farm	Wall same as F 161 cut by drain F(98)	
F161	A	2	3	1878-1898 Mill Corner Farm	Wall same as F(99) and F(160)	
F162	A	8	3	Post 1975 activity	Pit cuts drain F(5)	
[163]	B	6	9	1921 Mill Corner Farm	Cut of drain F(136), filled by (164), cut by (134), underlies rubble spread (76)	
(164)	B	6	9	1921 Mill Corner Farm	Fill of drain cut [163] - cut by F(134), underlies rubble spread (76)	

## APPENDIX 8: Photographic register

Photo Reg No	Digitl no	Area	Directi on taken from	Description of shot	Initials/date
1	7322	A	N	Brick drying Shed/ thatched cottage (BS/cott) footings, internal wall and flooring, with scale F(94), F(95)	DK 22/12/2016
2	7323	A	N	Brick drying shed/ thatched cottage footings, internal wall and flooring, with scale F(94) F(95)	DK 22/12/2016
3	7324	A	NE	BS/cott flooring, with scale F(94)	DK 22/12/2016
4	7325	A	SE	BS/cott brick footings F(25), F(30) cut by drains F(22) and F(23)	DK 23/12/2016
5	7327	A	E	BS F(25), F(30) cut by drain F(22) cut by water pipe F(23)	DK 23/12/2016
6	7329	A	NE	BS F(25), F(30) cut by drain F(22) cut by water pipe F(23)	DK 23/12/2016
7	7330	A	SE	Burnt wood fragments in situ, poss sapling	DK 30/12/2016
8	7333	A		Nameplate	DK 30/12/2016
9	7334	A	S	BS/cott brick footings general shot, with scale	DK 30/12/2016
10	7335	A	S	BS/cott brick footings general shot, with scale	DK 30/12/2016
11	7336	A	S	BS/cott brick footings general shot, with scale	DK 30/12/2016
12	7337	A	S	BS/cott brick footings, external wall F(25), with scale	DK 30/12/2016
13	7338	A	S	BS/cott brick footings, external wall F(25), with scale	DK 30/12/2016
14	7339	A	SW	BS/cott brick footings, external wall F(25), with scale	DK 30/12/2016
15	7340	A	SW	BS/cott brick footings, external wall F(25), with scale	DK 30/12/2016
16	7341	A	SW	BS/cott brick footings, external wall F(25), with scale	DK 30/12/2016
17	7343	A	SW	BS/cott brick footings, external wall F(25), with scale	DK 30/12/2016
18	7344	A	SW	BS/cott brick footings, external wall F(25), with scale	DK 30/12/2016
19	7345	A	SW	BS/cott brick footings, external wall F(25), with scale	DK 30/12/2016
20	7346	A	NW	BS/cott brick footings, doorway F(99), without scale	DK 30/12/2016
21	7347	A	N	BS/cott brick footings, doorway F(99), with scale	DK 30/12/2016
22	7348	A	N	Site strip, BS/cott footings, external wall, with scale	DK 30/12/2016
23	7349	A	N	Site strip, BS/cott footings, external wall, with scale	DK 30/12/2016
24	7350	A	SW	Site strip, BS/cott footings, without scale	DK 30/12/2016
25	7351	B		Area B nameplate	DK 30/12/2016
26	7353	B	W	Site strip, Mill Corner Farm, with scale	DK 30/12/2016
27	7354	B	W	Site strip, Mill Corner Farm, with scale	DK 30/12/2016
28	7355	B	NW	Site strip, Mill Corner Farm, without scale	DK 30/12/2016
29	7356	B	SW	Site strip, Mill Corner Farm, with scale	DK 30/12/2016
30	7357	B	S	Mill Corner Farm, walls F(56), F(68), chalk flooring layer (71), with scale	DK 30/12/2016
31	7358	B	S	Mill Corner Farm, walls F(56), F(68) chalk flooring layer (71), with scale	DK 30/12/2016
32	7359	B	S	Mill Corner Farm, wall F(68), chalk flooring layer (71), with scale	DK 30/12/2016
33	7361	A/B	NE	Site strip, Mill Corner Farm across pond from Area A, without scale	DK 02/01/2017
34	7362	A/B	NE	BS/cott footings F(25),F(30), F(95), F(97), F(99), without scale	DK 02/01/2017
35	7363	A	E	BrickdryingSheds/cott footings F(25), F(28), F(29), with scale	DK 02/01/2017
36	7364	A	E	BS/cott footings F(25), F(28), F(29), with scale	DK 02/01/2017
37	7365	A	E	BS/cott footings F(25), F(28), F(29) with scale	DK 02/01/2017
38	7366	A	SE	BS/cott footings F(25), F(28), without scale	DK 02/01/2017
39	7367	A	SE	BS/cott footings, F(25), F(27), F(28), without scale	DK 02/01/2017
40	7369	A	SE	BS/cott footings, F(25), F(27), F(28), without scale	DK 02/01/2017
41	7370	A	NE	BS/cott footings, F(25), F(27), F(28), F(29), F(30)	DK 02/01/2017
42	7371	A	NE	BS/cott footings and 1911 kiln location F(25), F(28), F(29), F(30)	DK 02/01/2017
43	7372	A	N	BS/cott footings and 1911 kiln location, walls F(25), F(28), F(29), F(30), drain F(22), with scale	DK 02/01/2017
44	7373	A	N	BS/cott footings and 1911 kiln location, walls F(25), F(30), with scale	DK 02/01/2017
45	7374	A	NW	1911 kiln location and drain F(87), F(88), without scale	DK 02/01/2017
46	7376	A	NW	1911 kiln location and drain F(87), F(88), with scale	DK 02/01/2017
47	7377	A	NW	1911 kiln location and drain F(87), F(88), with scale	DK 02/01/2017
48	7378	A	NE	1911 Mill Corner Farm Area A brick walls F(20), F(25) with scale	DK 02/01/2017
49	7380	A	S	1878-1898 kiln location, with scale	DK 02/01/2017
50	7381	A	SE	1878-1898 brick drying shed and kiln location, with scale	DK 02/01/2017
51	7382	A	S	1878-1898 kiln location, with scale	DK 02/01/2017
52	7383	A	SE	BS/cott footings, layer (17), walls F(29), F(30), without scale	DK 02/01/2017
53	7384	A	SE	BS/cott footings, layer (17), posthole F(18), walls F(25), F(28), without scale	DK 02/01/2017
54	7386	A	SE	BS/cott footings, layer (17), walls F(25), F(28), with scale	DK 02/01/2017
55	7387	A	SE	BS/cott footings, layer (17), walls F(25), F(28), with scale	DK 02/01/2017
56	7392	A	W	BS/cott footings, walls F(27), F(28), with scale	DK 02/01/2017
57	7393	A	W	BS/cott footings walls F(25), F(28), with scale	DK 02/01/2017
58	7394	A	W	BS/cott footings, walls F(25), F(28) without scale	DK 02/01/2017
59	7395	A	W	BS/cott footings, walls F(25), F(28) without scale	DK 02/01/2017
60	7396	A	W	BS/cott footings, walls F(25), F(28) without scale	DK 02/01/2017
61	7397	A	W	BS/cott footings, walls F(20), F(25), F(29), without scale	DK 02/01/2017
62	7398	A	W	BS/cott footings, walls F(25), F(29), without scale	DK 02/01/2017
63	7399	A	W	Bckground 1911 kiln location BS/cott footings, walls F(25), F(29), without scale	DK 02/01/2017
64	7400	A	W	Background 1911 kiln location BS/cott footings, drain F(22), modern water pipe F(23), walls F(25), F(30), without scale	DK 02/01/2017
65	7401	A	W	BS/cott footings, drain F(22), modern water pipe F(23), walls F(25), F(30), without scale	DK 02/01/2017
66	7402	A	W	BS/cott footings, walls F(25), F(30), internal F(93), without scale	DK 02/01/2017
67	7403	A	W	BS/cott footings, walls F(25), F(30), internal F(93), without scale	DK 02/01/2017
68	7405	A	W	BS/cott footings, walls F(25), F(30), flooring F(94), internal walls F(95), F(97), w/out scale	DK 02/01/2017
69	7406	A	W	BS/cott footings, walls F(25), F(30), internal walls F(95), F(97), doorway F(99), without scale	DK 02/01/2017

Photo reg no	Digit al no	Area	Directi on taken from	Description of shot	Initials/date
70	7407	A	W	BS/cott footings, walls F(25), F(30), internal walls F(97), doorway F(99) drain F(102), without scale	DK 02/01/2017
71	7410	A	S	BS/cott footings, with scale	DK 02/01/2017
72	7412	A	S	BS/cott footings, with scale	DK 02/01/2017
73	7413	A	W	BS/cott footings, flooring F(94), with scale	DK 02/01/2017
74	7414	A	W	BS/cott footings, flooring F(94), with scale	DK 02/01/2017
75	7415	A	NE	BS/cott footings, walls F(25), F(30), drain F(98), doorway F(99), without scale	DK 02/01/2017
76	7418	A	N	BS/cott footings, walls F(25), F(30), drain F(98), doorway F(99), without scale	DK 02/01/2017
77	7419	A	N	BS/cott footings, wall F(95), without scale	DK 02/01/2017
78	7420	A	W	BS/cott footings, wall F(25), without scale	DK 02/01/2017
79	7421	A	N	BS/cott footings, walls F(25), F(30), drain F(98), doorway F(99), with scale	DK 02/01/2017
80	7423	A	E	BS/cott footings F(99), F(30) and drain F(101), with scale	DK 02/01/2017
81	7424	A	E	BS/cott footings F(99), F(30) and drain F(101)	DK 02/01/2017
82	7426	A	N	BS/cott footings, drain F(98) and doorway F(99), without scale	DK 02/01/2017
83	7427	A	E	BS/cott footings, walls F(25), (30), drain F(98) and doorway F(99), with scale	DK 02/01/2017
84	7430	B	W	Site strip, Mill Corner Farm, with scale	CJS 03/01/2017
85	7431	B	W	Site strip, Mill Corner Farm with scale	CJS 03/01/2017
86	7432	B	W	Site strip, Mill Corner Farm, without scale	CJS 03/01/2017
87	7433	B	W	Site strip, Mill Corner Farm, without scale	CJS 03/01/2017
88	7434	B	W	Site strip, Mill Corner Farm, without scale	CJS 03/01/2017
89	7435	B	W	Site strip, Mill Corner Farm, without scale	CJS 03/01/2017
90	7436	B	S	Site strip, Mill Corner Farm, with scale	CJS 03/01/2017
91	7437	B	S	Site strip, Mill Corner Farm, with scale	CJS 03/01/2017
92	7438	B	S	Site strip, Mill Corner Farm, with scale	CJS 03/01/2017
93	7439	B	S	Site strip, Mill Corner Farm, without scale	CJS 03/01/2017
94	7440	B	S	Site strip, Mill Corner Farm, without scale	CJS 03/01/2017
95	7441	B	S	Site strip, Mill Corner Farm, without scale	CJS 03/01/2017
96	7442	B	S	Site strip, Mill Corner Farm, without scale	CJS 03/01/2017
97	7443	B	E	Site strip, Mill Corner Farm, without scale	CJS 03/01/2017
98	7444	B	E	Site strip, Mill Corner Farm, with scale	CJS 03/01/2017
99	7445	B	E	Site strip, Mill Corner Farm, with scale	CJS 03/01/2017
101	7446	B	E	Site strip, Mill Corner Farm, with scale	CJS 03/01/2017
102	7447	B	E	Site strip, Mill Corner Farm, without scale	CJS 03/01/2017
103	7448	B	E	Site strip, Mill Corner Farm, without scale	CJS 03/01/2017
104	7449	B	NE	Site strip, Mill Corner Farm, without scale	CJS 03/01/2017
105	7450	B	N	Site strip, Mill Corner Farm, with scale	CJS 03/01/2017
106	7451	B	N	Site strip, Mill Corner Farm, with scale	CJS 03/01/2017
107	7452	B	N	Site strip, Mill Corner Farm, without scale	CJS 03/01/2017
108	7453	B	N	Site strip, Mill Corner Farm, without scale	CJS 03/01/2017
109	7454	B	N	Site strip, Mill Corner Farm, without scale	CJS 03/01/2017
110	7455	B	N	Site strip, Mill Corner Farm, without scale	CJS 03/01/2017
111	7456	B	N	Site strip, Mill Corner Farm, without scale	CJS 03/01/2017
112	7457	B	NW	Site strip, Mill Corner Farm, without scale	CJS 03/01/2017
113	7459	A	W	BS/cott brick footings, wall F(30), with scale	CJS 05/01/2017
114	7460	A	W	BS/Cott brick footings, wall F(30), with scale	CJS 05/01/2017
115	7461	A	W	BS/cott brick footings, wall F(30), with scale	CJS 05/01/2017
116	7462	A	W	BS/cott brick footings, wall F(30), with scale	CJS 05/01/2017
117	7463	A	E	BS/cott brick footings, wall F(30), with scale	CJS 05/01/2017
118	7464	A	W	BS/cott brick footings, wall F(30), with scale	CJS 05/01/2017
119	7465	A	E	BS/cott brick footings, wall F(30), with scale	CJS 05/01/2017
120	7466	A	W	BS/cott brick footings, wall F(30), with scale	CJS 05/01/2017
121	7467	A	NW	BS/cott brick footings, wall F(30), without scale	CJS 05/01/2017
122	7468	A	N	BS/cott brick footings, doorway F(99), without scale	CJS 05/01/2017
123	7469	A	S	BS/cott drain tiles F(102), without scale	DK 05/01/2017
124	7470	A	S	BS/cott drain construction F(102), without scale	DK 05/01/2017
125	7471	A	S	BS/cott drain construction F(102), without scale	DK 05/01/2017
126	7472	A	SW	BS/cott drain F(102), without scale	DK 05/01/2017
127	7473	A	W	BS/cott brick footings, wall F(25), drain F(98), with scale	DK 05/01/2017
128	7475	A	W	BS/cott brick footings, wall F(22), drain F(98), with scale	DK 05/01/2017
129	7478	A	N	BS/cott drain F(98), doorway F(99), with scale	DK 05/01/2017
130	7479	A	N	BS/cott drain F(98), doorway F(99), with scale	DK 05/01/2017
131	7481	A	N	BS/cott drain F(98), doorway F(99), with scale	DK 05/01/2017
132	7482	A	N	BS/cott brick footings wall F(30), without scale	DK 05/01/2017
133	7484	A	N	BS chalk layer (2), without scale	DK 06/01/2017
134	7485	A	E	BS/kiln brick pad F(7), with scale	DK 06/01/2017
135	7486	A	E	BS/kiln brick pad F(8), with scale	DK 06/01/2017
136	7487	A	E	BS/kiln brick pad F(11), with scale	DK 06/01/2017
137	7488	A	E	BS/ drain F(4), with scale	DK 06/01/2017
138	7489	A	E	BS/ drain F(5), with scale	DK 06/01/2017
139	7490	A	E	BS/ drain associated with kiln structure F(6), with scale	DK 06/01/2017
140	7491	A	E	Post and packing , with scale F(12)	DK 06/01/2017
141	7492	B	W	Site strip 2, Mill Corner Farm, with scale	DK 06/01/2017
142	7493	B	W	Site strip 2, Mill Corner Farm, with scale	DK 06/01/2017
143	7494	B	NW	Site strip 2, Mill Corner Farm, with scale	DK 06/01/2017
144	7495	B	W	Site strip 2, Mill Corner Farm, with scale	DK 06/01/2017
145	7496	B	W	Site strip 2, Mill Corner Farm, with scale	DK 06/01/2017
146	7497	B	W	Site strip 2, Mill Corner Farm, with scale	DK 06/01/2017

Photo reg no	Digit al no	Area	Directi on taken from	Description of shot	Initials/date
147	7498	B	W	Site strip 2, Mill Corner Farm, with scale	DK 06/01/2017
148	7499	B	W	Site strip 2, Mill Corner Farm, without scale	DK 06/01/2017
149	7500	B	W	Site strip 2, Mill Corner Farm, without scale	DK 06/01/2017
150	7501	B	W	Site strip 2, Mill Corner Farm, without scale	DK 06/01/2017
151	7502	B	S	Site strip 2, Mill Corner Farm with scale	DK 06/01/2017
152	7503	B	S	Site strip 2, Mill Corner Farm, with scale	DK 06/01/2017
153	7504	B	S	Site strip 2, Mill Corner Farm, with scale	DK 06/01/2017
154	7505	B	S	Site strip 2, Mill Corner Farm, without scale	DK 06/01/2017
155	7506	B	SE	Site strip 2, Mill Corner Farm, without scale	DK 06/01/2017
156	7507	B	SE	Site strip 2, Mill Corner Farm, without scale	DK 06/01/2017
157	7508	B	SE	Site strip 2, Mill Corner Farm, without scale	DK 06/01/2017
158	7509	B	SW	Site strip 2, Mill Corner Farm, without scale	DK 06/01/2017
159	7510	B	SE	Site strip 2, Mill Corner Farm, without scale	DK 06/01/2017
160	7513	B	S	Post and packing F(38), with scale	DK 06/01/2017
161	7514	B	S	Post and packing F(40), with scale	DK 06/01/2017
162	7515	B	E	Pit? F(37), with scale	DK 06/01/2017
163	7516	B	E	Post and packing F(45), with scale	DK 06/01/2017
164	7517	B	S	Post and packing F(45), with scale	DK 06/01/2017
165	7518	B	S	Pit? cut [47], with scale	DK 06/01/2017
166	7519	B	S	Pit? cut [47], with scale	DK 06/01/2017
167	7520	B	S	Post and packing F(49), with scale	DK 06/01/2017
168	7521	B	S	Post and packing F(62), with scale	DK 06/01/2017
169	7522	B	S	Post and packing F(125), with scale	DK 06/01/2017
170	7523	B	S	Post and packing F(123), with scale	DK 06/01/2017
171	7524	B	S	Post and packing F(124), with scale	DK 06/01/2017
172	7525	B	S	Post and packing F(128), with scale	DK 06/01/2017
173	7526	B	S	Post and packing F(118), with scale	DK 06/01/2017
174	7528	A	E	BS/cott footings and drain F(100), with scale	DK 08/01/2017
175	7529	A	E	BS/cott footings and drain F(100), with scale	DK 08/01/2017
176	7530	A	S	Drain F(101), with scale	DK 08/01/2017
177	7531	A	S	BS/cott footings and drain F(101), with scale	DK 08/01/2017
178	7534	A	S	BS/cott footings and drain F(101), with scale	DK 08/01/2017
179	7536	A	S	Drains F(102) and F(103), without scale	DK 08/01/2017
180	7537	A	S	Drains F(102) and F(103), with scale	DK 08/01/2017
181	7541	B	W	Site strip 2 Mill Corner Farm, with scale	DK 09/01/2017
182	7543	B	W	Site strip 2 Mill Corner Farm, with scale	DK 09/01/2017
183	7544	B	NW	Site strip 2 Mill Corner Farm, with scale	DK 09/01/2017
184	7546	B	NW	Site strip 2 Mill Corner Farm, without scale	DK 09/01/2017
185	7547	B	W	Site strip 2 Mill Corner Farm, with scale	DK 09/01/2017
186	7548	B	NW	Site strip 2 Mill Corner Farm, with scale	DK 09/01/2017
187	7549	B	NW	Site strip 2 Mill Corner Farm, without scale	DK 09/01/2017
188	7551	B	N	Site strip 2 Mill Corner Farm, without scale	DK 09/01/2017
189	7552	B	N	Site strip 2 Mill Corner Farm, wall F(56) without scale	DK 09/01/2017
190	7553	B	N	Site strip 2 Mill Corner Farm, wall F(56) without scale	DK 09/01/2017
191	7554	B	N	Site strip 2 Mill Corner Farm, wall F(56) without scale	DK 09/01/2017
192	7555	B	N	Site strip 2 Mill Corner Farm, wall F(56) without scale	DK 09/01/2017
193	7556	B	E	Site strip 2 Mill Corner Farm brick footings, with scale	DK 09/01/2017
194	7557	B	E	Site strip 2 Mill Corner Farm brick footings, with scale	DK 09/01/2017
195	7558	B	E	Site strip 2 Mill Corner Farm brick footings, with scale	DK 09/01/2017
196	7559	B	E	Site strip 2 Mill Corner Farm brick footings, without scale	DK 09/01/2017
197	7560	B	E	Site strip 2 Mill Corner Farm brick footings, without scale	DK 09/01/2017
198	7561	B	E	Site strip 2 Mill Corner Farm brick footings, without scale	DK 09/01/2017
199	7562	B	E	Site strip 2 Mill Corner Farm brick footings, with scale	DK 09/01/2017
200	7563	B	E	Site strip 2 Mill Corner Farm brick footings, without scale	DK 09/01/2017
201	7564	B	E	Site strip 2 Mill Corner Farm brick footings, with scale	DK 09/01/2017
202	7565	B	E	Site strip 2 Mill Corner Farm brick footings, without scale	DK 09/01/2017
203	7566	B	E	Site strip 2 Mill Corner Farm brick footings, without scale	DK 09/01/2017
204	7567	B	E	Site strip 2 Mill Corner Farm brick footings, without scale	DK 09/01/2017
205	7569	B	S	Site strip 2 Mill Corner Farm brick footings, with scale	DK 09/01/2017
206	7570	B	S	Site strip 2 Mill Corner Farm brick footings, without scale	DK 09/01/2017
207	7571	B	S	Site strip 2 Mill Corner Farm brick footings, with scale	DK 09/01/2017
208	7572	B	S	Site strip 2 Mill Corner Farm brick footings, without scale	DK 09/01/2017
209	7573	B	S	Site strip 2 Mill Corner Farm brick footings, without scale	DK 09/01/2017
210	7575	B	S	Site strip 2 Mill Corner Farm brick footings, internal wall F(56), with scale	DK 09/01/2017
211	7576	B	S	Site strip 2 Mill Corner Farm brick footings, internal wall F(57), with scale	DK 09/01/2017
212	7577	B	W	Site strip 2 Mill Corner Farm brick footings, wall F(68), with scale	DK 09/01/2017
213	7578	B	W	Site strip 2 Mill Corner Farm brick footings, wall F(68), with scale	DK 09/01/2017
214	7579	B	W	Site strip 2 Mill Corner Farm brick footings, internal wall F(57), without scale	DK 09/01/2017
215	7580	B	W	Site strip 2 Mill Corner Farm brick footings, internal wall F(57), without scale	DK 09/01/2017
216	7581	B	W	Site strip 2 Mill Corner Farm brick footings, wall F(68), without scale	DK 09/01/2017
217	7582	B	W	Site strip 2 Mill Corner Farm brick footings, wall F(68), without scale	DK 09/01/2017
218	7583	B	W	Site strip 2 Mill Corner Farm brick footings, wall F(68), without scale	DK 09/01/2017
219	7584	B	W	Site strip 2 Mill Corner Farm brick footings, wall F(68), without scale	DK 09/01/2017
220	7585	B	W	Site strip 2 Mill Corner Farm brick footings, external wall F(55), with scale	DK 09/01/2017
221	7586	B	W	Site strip 2 Mill Corner Farm brick footings, external wall F(55), with scale	DK 09/01/2017
222	7587	B	W	Site strip 2 Mill Corner Farm brick footings, external wall F(55), without scale	DK 09/01/2017
223	7588	B	W	Site strip 2 Mill Corner Farm brick footings, external wall F(55), without scale	DK 09/01/2017

Photo reg no	Digit al no	Area	Directi on taken from	Description of shot	Initials/date
224	7589	B	W	Site strip 2 Mill Corner Farm brick footings, external wall F(55), without scale	DK 09/01/2017
225	7590	B	W	Site strip 2 Mill Corner Farm brick footings, external wall F(55), without scale	DK 09/01/2017
226	7591	B	W	Site strip 2 Mill Corner Farm brick footings, external wall F(55), without scale	DK 09/01/2017
227	7592	B	W	Site strip 2 Mill Corner Farm brick footings, external wall F(55), without scale	DK 09/01/2017
228	7594	B	S	Post and packing [45], with scale	DK 10/01/2017
229	7595	B	S	Post and packing [45], with scale	DK 10/01/2017
230	7596	B	E	Post and packing [45], with scale	DK 10/01/2017
231	7597	B	S	Post and packing [47], with scale	DK 10/01/2017
232	7598	B	S	Post and packing [127], with scale	DK 10/01/2017
233	7599	B	S	Post and packing [127], with scale	DK 10/01/2017
234	7600	B	S	Post and packing [127], with scale	DK 10/01/2017
235	7601	B	S	Post and packing [119], with scale	DK 10/01/2017
236	7602	B	S	Post and packing [73], with scale	DK 10/01/2017
237	7604	B	S	Post and packing [73], with scale	DK 10/01/2017
238	7605	B	S	Post and packing [72], with scale	DK 10/01/2017
239	7606	B	S	Post and packing [72], with scale	DK 10/01/2017
240	7608	B	N	Rectangular slot [134] and drain F(136), with scale	DK 10/01/2017
241	7609	B	N	Rectangular slot [134] and drain F(136), with scale	DK 10/01/2017
242	7610	B	N	Rectangular slot [134] and drain F(136), with scale	DK 10/01/2017
243	7611	B	N	Rectangular slot [134], with scale	DK 10/01/2017
244	7612	B	N	Drain F(136), with scale	DK 11/01/2017
245	7613	B	N	Site strip, Mill Corner Farm, with scale	DK 11/01/2017
246	7614	B	N	Site strip, Mill Corner Farm, with scale	DK 11/01/2017
247	7615	B	N	Site strip, Mill Corner Farm, with scale	DK 11/01/2017
248	7616	B	N	Site strip, Mill Corner Farm, with scale	DK 11/01/2017
249	7617	B	N	Site strip, Mill Corner Farm, with scale	DK 11/01/2017
250	7618	B	N	Site strip, Mill Corner Farm, with scale	DK 11/01/2017
251	7619	B	E	Site strip, Mill Corner Farm, with scale	DK 11/01/2017
252	7620	B	E	Site strip, Mill Corner Farm, with scale	DK 11/01/2017
253	7621	B	E	Site strip, Mill Corner Farm, without scale	DK 11/01/2017
254	7622	B	E	Site strip, Mill Corner Farm, without scale	DK 11/01/2017
255	7623	B	E	Site strip, Mill Corner Farm, without scale	DK 11/01/2017
256	7624	B	E	Site strip, Mill Corner Farm, with scale	DK 11/01/2017
257	7625	B	S	Post and packing [35], with scale	DK 11/01/2017

## **APPENDIX 9: Metal detecting report**



## APPENDIX 10 HERTFORDSHIRE HISTORIC ENVIRONMENT RECORD SUMMARY SHEET

Site name and address: The Farmyard, Brickyard Lane, Reed, Hertfordshire		
County: Hertfordshire	District: North Hertfordshire	
Village/Town: Reed	Parish: Reed	
Planning application reference: 15/1725/1		
HER Enquiry reference: 196/16		
Funding source: Commercial		
Nature of application: Commercial		
Present land use: Agricultural and Industrial		
Size of application area: 0.66 ha	Size of area investigated: 0.20ha	
NGR (to 8 figures minimum): TL3608 3646		
Site code (if applicable): REEDBL15		
Site director/Organization: Archaeology, Excavation and Surveys.		
Type of work: Archaeological Strip, Map and Record		
Date of work:	Start: 15 <sup>th</sup> December	Finish: 12 <sup>th</sup> January
Location of finds & site archive/Curating museum: Stored at present in AES offices to be deposited with appropriate Hertfordshire Museum		
Related HER Nos: 11427, 15082, 15352. EHT4688, EHT7091, EHT4980, EHT7780	Periods represented: Medieval, Post-medieval	
Relevant previous summaries/reports Doel, Peter. 1999. Mill Corner, Jacksons Lane, Reed: archaeological observation and recording. watching brief. RNO 893 Waring, William. 2014. The Farmyard, Brickyard Lane, Reed, Hertfordshire: an archaeological desk-based assessment. desk-based assessment. RNO 3298		
Summary of fieldwork results: <i>Archaeology, Excavation and Surveys completed an archaeological strip, map and record between the 15th December 2016 to 12<sup>th</sup> January 2017 on approximately 0.20 hectares of former agricultural and industrial land on the edge of Reed village, in response to a planning requirement set by Andy Instone of Hertfordshire Environment Team prior to the development of the Proposed Development Area (PDA) with twelve dwellings, associated services and access (planning refs: 14/02573/1 &amp; 15/01725/1). The investigation discovered nine phases of activity on the Proposed Development Area (PDA) and primarily revealed the PDA's historical use as a brickworks and as a farm, dating it from the 19th Century. Within this eight phases and seventeen groups were identified; <b>phase one</b> – pre 1878 activity; <b>phase two</b> - 1878-1898 Brickwork remnants; <b>phase three</b> - 1911 Brickwork remnants; <b>phase four</b> - 1911 Area B Mill Corner Farm; <b>phase five</b> - 1921 Area A Mill Corner Farm; <b>phase six</b> – 1921 Area B Mill Corner Farm; <b>phase seven</b> - 1975 Agricultural/industrial buildings Areas A/B; <b>phase eight</b> - Post 1975 activity Areas A/B; <b>phase nine</b> - Undated. Modern overburden was found over the site within Areas A and B representing the demolition of farm buildings prior to archaeological investigations (Waring, 2014). The layer of modern overburn covered layers granulated chalk possibly the hardstanding and access road to the Brickworks and Mill Corner Farm in Area A. A sandy layer was also present in Area A. The brick foundations of a thatched cottage consisting of three bedroom, a pantry and attached drying shed, and possible remnants of a brick-built kiln were also found in Area A along with associated 19<sup>th</sup> century clay drains, and also brick remnants of 20<sup>th</sup> century Mill Corner Farm and associated drains. A large area of brick rubble and dust relating to the sites use during the 19<sup>th</sup> century as a Brickworks was also revealed in Area A. A further single light tan brick to that found in the evaluation was found at the southern end of Area A (Doig, 2016). The layer of modern overburn also covered layers of mortar/concrete flooring, granulated chalk and brick foundations of Mill Corner Farm with associated posted outbuildings and 20th century clay drains in Area B. No archaeological stratified finds were recovered. Modern features revealed in Area A included a linear containing a water pipe and two investigation slots In Area B two further investigation slots were revealed. Ordnance survey (OS) maps from 1878 to 1911 show the presence of the brickworks, but which are no longer evident on the 1921 OS map. From the 1921 OS map, Mill Corner Farm is shown occupying the southern half of the PDA, however on the 1975 OS map only Farm buildings remain, Mill Corner Farm itself being relocated. Additionally, metal detecting of Area B recovered a 19th century shirt and RAF button, 19th century latch key and 19th century brass door knob (Parker, 2017).</i>		
Author of summary: Dawn Keen	Date of summary: 17 <sup>th</sup> February 2017	