



WYAS  
**Archaeological  
Services**

**Great North Road  
Micklefield  
West Yorkshire**

Archaeological Evaluation

Report no. 3003  
August 2017

**Client:** Prospect Archaeology



# Great North Road, Micklefield West Yorkshire

## Archaeological Evaluation

### *Summary*

*An evaluation undertaken off Great North Road, Micklefield, West Yorkshire comprised the excavation of nine trenches 50m long trenches, following a geophysical survey of the site. Evidence for a series of ditches running across the site was found, particularly in the north-western half of the site. All the ditches have similar, rectilinear alignments, appearing to respect the orientation of Great North Road. This suggests they form the boundaries of plots lining the road. Dating material from the ditches was limited to one sherd of medieval pottery, though this represents a likely date for the features. Two pits also produced medieval pottery and a cache of charred material. These may represent evidence of nearby medieval settlement and suggest the potential for other similar features to lie in the north-western extent of the site.*



## Report Information

Client: Prospect Archaeology  
Address: Prospect House, Garden Lane, Sherburn-in-Elmet, Leeds  
Report Type: Archaeological Evaluation  
Location: Micklefield  
County: West Yorkshire  
Grid Reference: SE 442 433  
Period(s) of activity represented: Medieval  
Report Number: 3003  
Project Number: 6590  
Site Code: GNR17  
Planning Application No.: 13/02271/OT  
Museum Accession No.: TBC  
Date of fieldwork: June 2017  
Date of report: August 2017  
Project Management: David Williams BA MCIfA  
Fieldwork supervisor: Iain McIntrye MA  
Report: Matt Wells BSc MA  
Illustrations: Matt Wells  
Photography: Site staff  
Specialists: Andrew Sage (pottery)  
Diane Alldritt (carbonised plant macrofossils and charcoal)  
Zoe Horn (metal finds)

Authorisation for  
distribution: \_\_\_\_\_



© Archaeological Services WYAS 2017  
Nepshaw Lane South, Morley, Leeds LS27 7JQ  
Telephone: 0113 383 7500.  
Email: [admin@aswyas.com](mailto:admin@aswyas.com)



## Contents

Report information .....	ii
Contents.....	iii
List of Figures .....	iv
List of Plates.....	iv
List of Tables .....	iv
<b>1 Introduction.....</b>	<b>1</b>
Site location, topography and land use .....	1
Soils and geology.....	1
<b>2 Archaeological and Historical Background.....</b>	<b>1</b>
<b>3 Aims and Objectives .....</b>	<b>2</b>
<b>4 Methodology .....</b>	<b>3</b>
<b>5 Results .....</b>	<b>4</b>
Trench 1 .....	4
Trench 2 .....	4
Trench 3 .....	5
Trench 4 .....	5
Trench 5 .....	5
Trench 6 .....	6
Trench 8 .....	6
<b>6 Artefact Record.....</b>	<b>6</b>
Pottery.....	6
Metal finds .....	7
<b>7 Environmental Record .....</b>	<b>7</b>
Carbonised plant macrofossils and charcoal.....	7
<b>8 Discussion .....</b>	<b>9</b>
<b>9 Conclusions.....</b>	<b>10</b>

Figures

Plates

### Appendices

Appendix 1: Specification

Appendix 2: Inventory of primary archive

Appendix 3: Trench tables

### Bibliography

## **List of Figures**

- 1 Site location
- 2 Site plan showing trench locations and interpretation of magnetometer data
- 3 Trench 1 feature plans and sections
- 4 North-west facing section of Trench 1
- 5 Trench 2 plan and sections
- 6 Trench 3 NW end, plan and sections
- 7 Trench 3 SE end, plan and section
- 8 Trench 4 plan and section
- 9 Trench 5 plan and section
- 10 Trench 6 plan and section
- 11 North-facing sample section of Trench 7
- 12 Trench 8 plan and section
- 13 Earthwork Survey

## **List of Plates**

- 1 Trench 1, looking north-east
- 2 Trench 2, looking north-west
- 3 Trench 4, looking north-east
- 4 Trench 5, looking north-west
- 5 Trench 6, looking south-east
- 6 Trench 7, looking east
- 7 Trench 8, looking east
- 8 North-facing section of Ditch 803
- 9 Trench 9, looking north
- 10 East-facing section of sondage in Trench 9

## **List of Tables**

- 1 Summary of pottery finds
- 2 Summary of carbonised plant macrofossils and charcoal

## **1 Introduction**

Archaeological Services WYAS (ASWYAS) were commissioned by Nansi Rosenberg of Prospect Archaeology to undertake an archaeological evaluation on land off Great North Road, Micklefield, West Yorkshire, in advance of a proposed residential development. The evaluation was carried out in accordance with the requirements of the National Planning Policy Framework (2012), a specification produced by West Yorkshire Archaeology Advisory Service (WYAAS, see Appendix 1) and employing standards laid down by Historic England (2006; 2008) and the Chartered Institute for Archaeologists (2014). The evaluation was carried out in June 2017.

### **Site location and topography and land-use**

The site consists of an irregularly-shaped parcel of land, measuring 2.9ha in total, located to the east edge of Old Micklefield, east of Great North Road (Fig. 1). A small stream, the Sheep Dike, runs north-west to south-east through the site dividing it into two and the site slopes down from properties lining the Great North Road in the west to the “valley” of Sheep Dike in the east. The site is currently used as agricultural pasture. The site is centred on National Grid Reference SE 442 433 and lies between 50m and 58m above Ordnance Datum.

### **Soils and geology**

The solid geology across the site consists of Dolostone of the Cadeby Formation - sedimentary bedrock formed approximately 251 to 271 million years ago in the Permian Period, formed in shallow carbonate seas (British Geological Survey 2016). The soils are classified in the Aberford association, described as shallow, locally brashy, well-drained calcareous soils over limestone (Soil Survey of England and Wales 1983).

## **2 Archaeological and Historical Background**

The site lies within a landscape of high archaeological potential, with a large number of archaeological features mapped locally as cropmarks and a number of archaeological investigations carried out in the vicinity. These consist largely of remains dating from the Bronze Age through Iron Age and Roman periods to medieval and post-medieval. The site is also located in the historic township of Micklefield. The following archaeological background is taken from the Specification (Appendix 1).

Late prehistoric and Roman period settlements have been identified, generally taking the form of small discrete farmsteads surrounded by a ditch and bank and comprising the buried remains of round houses, pits, hearths and post-holes. A network of trackways and field boundaries lie between settlements. Other features include burial monuments such as ring ditches which are assumed to be ploughed out Bronze Age barrows, individual and groups of cremations and inhumation burials. Roman Ridge, the main north-south Roman Road lies *c.*2km to the west of Micklefield.

During the early medieval period the site lay in the Kingdom of Elmet. A village or settlement of Micleanfield is recorded in the possession of the Archbishop of York in 963 but Micklefield is not recorded in the Domesday Book of 1086. Whilst there is some evidence to suggest the village later developed as a medieval settlement this has not been proven by recent archaeological work.

However, the presence of evidence relating to both medieval cultivation in strip fields (ridge and furrow) and the earthworks standing in the northern part of the site suggest there is potential for remains of the medieval or later periods to be present. These earthworks comprise an east-west bank with a more complex rectangular enclosure attached at its eastern end and aligned with the Sheep Dike. The assertion made by Wheater in the late 19th century that remains of buildings were found to the immediate north in Hall Garth further suggests medieval activity within the site (West Yorkshire Historic Environment Record PRN 2838). The earthworks, which historic maps show extend beyond the site to the west, have not been fully characterised. It has been suggested that they may relate to a water-powered corn mill. However, this assumption remains unproven and they may have fulfilled other agricultural roles requiring the control of the Sheep Dike. The creation of flood meadows, to promote early growth of meadow grass being one possible function, whilst the assumed water mill site may conceivably be a sheep wash. Standing remains, in the form of grass covered earthworks, are present in the northern part of the site and may be medieval or post-medieval in date.

In November 2016, a cart-based geophysical (magnetometer) survey, covering approximately 3 hectares, was carried out on the site (Goulding 2016). Throughout the site there is a number of anomalies which were interpreted as agricultural in origin, and represent arable cultivation of the land from the early post-medieval period onwards. These are combined with a series of large parallel anomalies which are likely to represent the archaeological remains of a medieval or earlier strip-field system, with long linear boundaries running downslope and perpendicular minor boundaries subdividing the fields. Combined with a possible enclosure in the north-western corner, the archaeological potential of this site is considered to be high.

### **3 Aims and Objectives**

The overall aim of the evaluation was to assess the site for previously untested archaeological remains and record the location, extent, date, nature, character and relationships of any surviving archaeological remains uncovered ahead of development works. The objective was to establish the potential impacts of the development scheme upon any archaeological features uncovered and determine any need for further mitigation.

Specific objectives of the archaeological evaluation were to:

- Excavate archaeological evaluation trenches as specified;
- Identify archaeological features and deposits of interest;

- Excavate and record any identified archaeological features and deposits to a level to enable their nature and significance to be identified;
- Undertake sufficient post-excavation analysis to confidently interpret archaeological features identified during site works;
- Undertake sufficient post-excavation analysis of artefacts and samples to identify the potential scope for detailed analysis in future mitigation;
- Report the results of the investigations in the field and subsequent post-excavation analysis and place these results within their local and regional context;
- Compile and deposit a site archive at a suitable repository.

## 4 Methodology

Excavation of the trenches was carried out using a mechanical excavator equipped with a toothless ditching bucket under direct archaeological supervision. Soil was removed in level spits of no more than 0.2m until either the top of the first archaeological horizon or undisturbed natural was reached. The resulting surface was inspected for archaeological remains. Ditches were excavated in order to investigate their depth and profile and to recover finds, while discrete features encountered were at least 50% sampled.

A full written, drawn and photographic (35mm monochrome and digital) record of all material revealed during the course of the work was made. The trench locations were set out using GPS survey equipment with hand drawn trench plans and sections produced at a suitable scale and tied to the Ordnance Survey National Grid. All sections, plans and elevations included spot-heights related to Ordnance Datum in metres as correct to two decimal places.

All artefacts recovered were retained and removed from the site for assessment, with soil samples taken of deposits, where appropriate, in order to identify and recover carbonised and waterlogged remains, vertebrate remains, molluscs and small artefactual material.

An inventory of the primary archive is presented in Appendix 2, and a tabulated summary of results by trench is presented in Appendix 3. ASWYAS currently hold the site archive in a stable and secure location, but it will be deposited with the local museum for long-term storage in due course.

All excavation was undertaken in line with the CIfA guidelines Standard and Guidance for Archaeological Field Evaluation (2014), the Historic England MoRPHE PPN3: Archaeological Excavation (2008) and in compliance with ASWYAS's own methodologies (ASWYAS 2011).



## 5 Results

Trench locations are shown in Fig. 2 and the results of each trench are recorded in Appendix 3. A description of each trench in which archaeology was encountered is given below, with further details about the depths and descriptions of individual deposits provided in Appendix 3. Trenches devoid of archaeology are not discussed further but are tabulated below.

The underlying geology largely consisted weathered limestone bedrock and a mid-orangey-brown sandy-clay. Trenches 1-3, 6 and 8 were excavated through topsoil and subsoil onto natural geology, while the remaining trenches were also excavated through a variety of other deposits. These include natural alluvial and colluvial deposits and imported made ground. The naturally deposited layers are found in lower lying ground in Trenches 4, 5 and 7.

The archaeological features comprise ditch features, many of which correlate well with the results of the geophysical survey, and a small number of pits. These generally cut the natural bedrock and were sealed by the overburden, but in some cases they cut through other natural deposits. Finds from the evaluation consist of a small assemblage consisting of medieval pottery, metalwork and a cache of charred material finds from a pit in Trench 3 and a sherd of medieval pottery from a ditch in Trench 6.

### Trench 1 (Figs 3 and 4, Plate 1)

A pair of ditches were excavated at each end of the trench, each corresponding with a geophysical anomaly. An intermediate geophysical anomaly was not identified. Each ditch cut the natural geology and were sealed by the subsoil. A large cut (106, shown in section only) in the centre of the trench cut the subsoil and was backfilled with modern demolition material (107).

Ditch 102 had a north to south alignment and crossed the trench at its southern end. Its single fill (103) contained no finds.

Ditch 105 crossed the north-eastern end of the trench with a north-west to south east alignment. Its single fill (104) contained no finds.

### Trench 2 (Fig. 5, Plate 2)

Three ditches were excavated, two of which corresponded with geophysical anomalies. Each had a south-west to north-east orientation, cut the natural geology and was sealed by the subsoil.

Ditch 203 crossed the centre of the trench, measuring 1.10m wide and 0.50m deep and correlated closely with a geophysical anomaly. Its single fill (204) contained no finds.

Ditch 207 crossed the north-western end of the trench, measuring 2.00m wide and 0.50m deep. It was a substantial feature and correlated closely with a geophysical anomaly, but its single fill (208) was comparatively light in colour, and, coupled with diffuse edges, may suggest a non-archaeological origin.

Ditch 205 ran between the two ditches described above, measuring 0.50m wide and 0.37m deep. Its single fill (206) contained no finds.

### **Trench 3 (Figs 6 and 7)**

Trench 3 targeted two south-west to north-east aligned linear geophysical anomalies at its north-western end. These correlate closely with the ditches discussed below. The archaeology cut the natural geology and was sealed by the subsoil.

Ditch 302 measured 2.30m wide and 0.83m deep, orientated approximately south-west to north-east. Its single fill (303) contained no finds.

Ditch 314 crossed the trench towards its north-western end, measuring 3.55m wide and 0.87m deep. Its single fill contained no finds.

Pit 304 lay towards the south-eastern end of the trench and measured 3.90m long, at least 1.55m wide and 0.26m deep. It contained three fills (305-307). The upper and lower fills (305 and 307) contained pottery dating to between the mid-11th century and the late 13th century and the middle fill (306) contained a cache of charred material including bread wheat, oat, oak charcoal and garden pea. Fill 307 also contained two metal items, a copper alloy key and a iron pincher the associated pottery suggests a medieval date.

Two intercutting pits (308 and 312) were also excavated to the south-east of Pit 304. The later pit (312) measured 1.02m long, at least 1.30m wide and 0.40m deep. Its single fill (313) contained modern pottery which was not retained. Pit 308 was earlier and measured 2.22m long, at least 1.40m wide and 0.30m deep, containing three fills (309-311). The uppermost fill (311) contained pottery with a date range between the mid-11th century and early 13th century.

### **Trench 4 (Fig. 9, Plate 3)**

This trench was excavated through topsoil and subsoil at the surface, with a small amount of redeposited limestone (402) and a lens of clay and sand (403) found beneath the subsoil at the south-eastern end of the trench. A geophysical anomaly crossed the trench at its south-eastern end, running south-west to north-east. This correlates with the two intercutting ditches described below.

Ditch 404 was later and measured 0.75m wide and 0.51m deep and contained a single fill (405) with no finds.

Ditch 406 was earlier and measured 0.80m wide and 0.21m deep. It contained two fills, an upper fill (407) and lower fill (408) from which a sterile sample was taken.

A layer of colluvium (409), measuring up to 0.51m deep, was cut by Ditch 404 and sealed the natural limestone.

### **Trench 5 (Fig. 10, Plate 4)**

Trench 5 was excavated through the topsoil, subsoil and a layer of naturally deposited material (502), possibly alluvial in origin. These layers sealed a ditch which correlated with a geophysical anomaly towards its north-western end.

Ditch 505 had a south-west to north-east alignment and measured 1.75m wide and 0.55m deep. Its single fill (506) contained no finds. It cut a second layer of naturally deposited material (503), possibly alluvial or colluvial in origin, which sealed the limestone bedrock.

#### **Trench 6 (Fig. 11, Plate 5)**

A pair of ditches were excavated which may correlate with one of several weak geophysical anomalies. Each ditch cut the natural geology and was sealed by the subsoil.

Ditch 603 lay near the centre of the trench, measured 0.80m wide and 0.11m deep and had a south-west to north-east alignment. It contained a single fill (604) from which a sherd of mid-11th to early 13th-century pottery was recovered.

Ditch 605 had a north-west to south-east alignment, roughly perpendicular to that of Ditch 603, and crossed the trench towards its north-western extent. It measured 1.06m wide and 0.22m deep. It contained two fills (606 and 607), neither of which contained any finds.

#### **Trench 8 (Fig. 12, Plate 7 and 8)**

A single ditch was excavated which correlates strongly with a linear geophysical anomaly crossing the trench towards its western limit, with a roughly south-west to north-east orientation. The ditch cut the natural geology and was sealed by the subsoil and a stoney made ground layer (802).

Ditch 809 measured 2.40m wide and 1.87m deep and it displayed a highly irregular profile contained a single fill (805). It contained no finds and the soil sample taken from it was sterile.

## 6 Artefact Record

### Pottery by Andrew Sage

A small assemblage of eight sherds (254g) of medieval pottery was recovered from two trenches, spanning the mid-11th to late 13th century in date. The assemblage was recorded, as per the Standard for Pottery Studies (PCRG, SGRP and MPRG 2016) onto a database, and measured by sherd count and weight. No form sherds were present in the assemblage.

Table 1. Summary of pottery finds

Trench	Ctx	FABCODE	Form	Sh	Wt	TAQ	TPQ	Comments
3	305	YG	jar/cp?	2	56	Lt C11	E C13	
3	307	HILLAM	hv	1	18	M C11	E C13	Sooted ext.
3	307	YG		1	10	Lt C11	E C13	Sooted ext.
3	307	HALLB	hv	1	7	Lt C12	Lt C13	pale olive glaze ext.
3	311	YG	hv	1	121	Lt C11	E C13	Sooted ext.
3	311	HILLAM	jar/cp?	1	36	M C11	E C13	Sooted ext.
6	604	MEDLOC GR		1	6	M C11	E C13	Abraded, sooted ext.
Total Pottery				8	254			
Average sherd weight				32				

The assemblage is dominated by gritty wares specifically Hillam (HILLAM) and Yorkshire Gritty (YG) wares. These are typically dated to the mid-11th to early 13th century (Mainman and Jenner 2013), however work at Pontefract has indicated that the Hillam ware industries may have pre-conquest origins (Roberts *et al.* 2013).

The only glazed/fineware sherd is a sherd of Doncaster Hallgate type B (HALLB) ware. Production of this type is typically dated to the late 12th to late 13th century (Buckland *et al.* 1979).

One sherd of pottery is of an unidentified medieval gritty type (MEDLOC GR) from Trench 6 (604). The coarse gritted fabric was a pale reddish brown with a pale grey core and moderate to abundant mica was visible in the surfaces. This sherd is significantly more abraded than the material from Trench 3.

Although the assemblage is small the high average sherd weight of the material from Trench 3 (35g) suggests that this material, came from primary deposits and not from re-deposited

midden or manuring material and that the pottery is evidence of 12th to early 13th-century occupation.

### **Metal finds** by Zoe Horn

Two metal objects were recovered from the single fill (307) of Pit 304 (Trench 3). The first is a copper alloy key. The key has a broken handle, with the remaining loop "U" shaped. There is a small bulge at the neck with a vertical line across the top and bottom of the bulge. The end of the body is hollow. The bit is rectangular with two key wards cut into the sides and one cut horizontally from the bottom to the centre. The second find is a pair of possible iron pinchers of indeterminate date, with a highly corroded loop.

## **7 Environmental Record**

### **Carbonised plant macrofossils and charcoal** by Diane Alldritt

Three environmental sample flots were examined for carbonised plant macrofossils and charcoal. Bulk environmental samples were processed by Archaeological Services WYAS using a Siraf-style water flotation system (French 1971). Samples were 5-20 litres in volume. The flots were dried before examination under a low power binocular microscope typically at x10 magnification. All identified plant remains including charcoal were removed and bagged separately by type. Wood charcoal was examined using a high powered Vickers M10 metallurgical microscope at magnifications up to x200. The reference photographs of Schweingruber (1990) were consulted for charcoal identification. Plant nomenclature utilised in the text follows Stace (1997) for all vascular plants apart from cereals, which follow Zohary and Hopf (2000).

Two of the environmental samples were found to be largely sterile of carbonised remains producing only traces of degraded charred detritus, probably decayed charcoal, in amounts <2.5ml, whilst the third contained a greater concentration of charcoal fragments, cereal grain and other remains. Modern material was fairly scarce indicating a small degree of bioturbation. Traces of clinker were also noted in one of the samples. Results are given in Table 2 and discussed below.

Ditch 803 (fill 804, sample 1) produced traces of degraded charred material, together with a small amount of snail shell and a single fragment of clinker. This feature is possibly post-medieval or has been disturbed by more recent activity.

Ditch 406 (fill 408, sample 2) was similar with only a few small slivers of charred detritus present, together with snail shell.

Pit 304 (fill 306, sample 300) produced a small concentration of cereal grain amongst crushed and degraded oak charcoal with occasional 10mm-15mm charcoal fragments present. A few of the cereal grains are well preserved and can be identified as *Triticum aestivum* (bread wheat), with a single *Avena sp.* (oat) also found. Four specimens of *Pisum sativum*

(garden pea) were recorded, and this may have been grown as a fodder crop or for human consumption. The charcoal was exclusively identified as *Quercus* (oak) probably being used as fuel in cereal drying processes or for cooking. The pit could have been a fire pit with material burnt in situ, or a waste pit for general disposal of mixed burnt waste, but as the carbonised material is mostly in good condition it had not moved far from the location of burning.

Table 2. Summary of carbonised plant macrofossils and charcoal

	Context	306	408	804
	Sample	300	2	1
	Feature	pit	ditch	ditch
	Total sample volume	5 litres	10 litres	10 litres
	Total CV	20ml	<2.5ml	<2.5ml
	Modern	5ml	10ml	<2.5ml
Carbonised Cereal Grain	Common name			
<i>Avena</i> sp.	oat	1		
<i>Triticum aestivum</i>	bread wheat	10		
Indeterminate cereal grain (+embryo)		16		
Charcoal				
<i>Quercus</i>	oak	6 (0.66g)		
Carbonised Weeds				
<i>Pisum sativum</i>	garden pea	4		
Other Remains				
Non-marine mollusc (snail) shell			5+	10+
Clinker				1

## 8 Discussion

The evaluation was largely successful in investigating the potential for archaeological features or deposits to survive on the site.

The geophysical survey is considered to be a reliable indication of the archaeological features on the site and the clearest anomalies correlate closely with the results of the evaluation. The weaker anomalies, however, produced mixed results. In Trench 6 they correlated well with two small ditches, but in Trenches 4 and 5, no archaeological features were found to coincide with the anomalies. Trench 1 contained a large cut, backfilled by modern demolition debris which appears to relate to the large anomaly recorded crossing the centre of the trench. Trench 7, 8 and 9 were excavated through modern demolition deposits which probably relate to the large areas of magnetic disturbance recorded during the geophysical survey in the south-eastern half of the site.

Trenches 1-6 and Trench 8 produced evidence of a series of ditches across the site, particularly to the north-west of the site, some of which were significant, large features. The ditches are all on similar alignments, running either north-west to south-east or north-east to south-west, and there is a possibility that they represent a contemporary system of boundaries, particularly those in Trenches 1-3 and 5. The alignments respect that of Great North Road and may represent plot divisions between properties lining the road. Unfortunately the soil samples taken from two ditch fills proved to be sterile and finds were limited to a single sherd of 11th-13th-century pottery, though a broadly medieval date for the features is likely. Re-cutting of features was noted in some cases, suggesting multiple phases of silting and re-cutting, and the use of features over an extended period.

In addition to the ditches, a total of three pits were excavated in Trench 3, two in particular representing more direct evidence of nearby settlement. Pit 312 contained modern pottery but both Pit 304 and 308 are probably contemporary with the ditch system, each producing 11th-13th-century pottery. Pit 304 also contained a cache of charred material. The cereal grain from the pit was found to be mostly bread wheat, with a small amount of oat, whilst peas were possibly also grown for fodder or food. Oak was the only charcoal type recorded from the samples, probably used for fuel. The two metal finds, of indeterminate date, were also found in Pit 304. Given the well-dated pottery finds also recovered from the pit, it is likely that these metal finds are also medieval in date. The north-western end of the site, particularly the area around Trench 3, has a high potential to contain further evidence of nearby settlement.

Two irregular features located within the western end of Trench 2, and the only feature in Trench 8, may represent palaeochannels or features associated with the creation of flood meadows. The earthwork survey (Fig. 9) taken during the geophysical survey clearly demonstrates that earthworks survive in the northern part of the site, perhaps with channels and/or flat areas running towards the south-east. Parts of these have been clearly infilled. No definitive evidence of palaeochannels, however, were noted from the earthwork survey.

## **9 Conclusions**

The evaluation off Great North Road produced evidence of a series of ditches running across the site, found particularly in the north-western half of the site. All the ditches have similar, rectilinear alignments, appearing to respect the orientation of Great North Road. This suggests they form the boundaries of plots lining the road. Dating material from the ditches was limited to one sherd of medieval pottery, though this represents a likely date for the features. The ditches possibly represent a broadly contemporary system of boundaries. Two pits in Trench 3 also produced medieval pottery and a cache of charred material. These may represent evidence of nearby medieval settlement and suggest the potential for other similar features to lie in this area of the site.

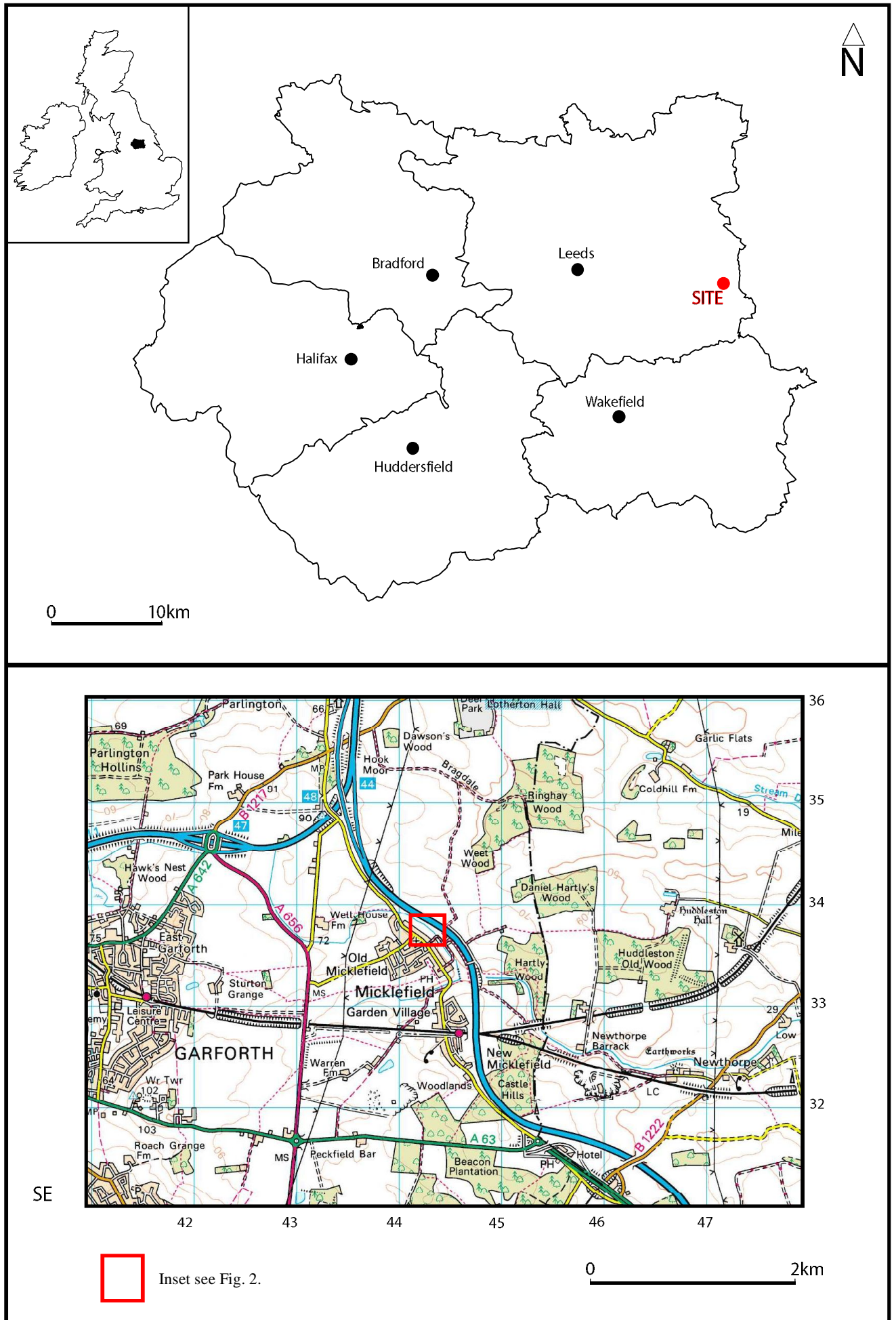

Fig. 1. Site location



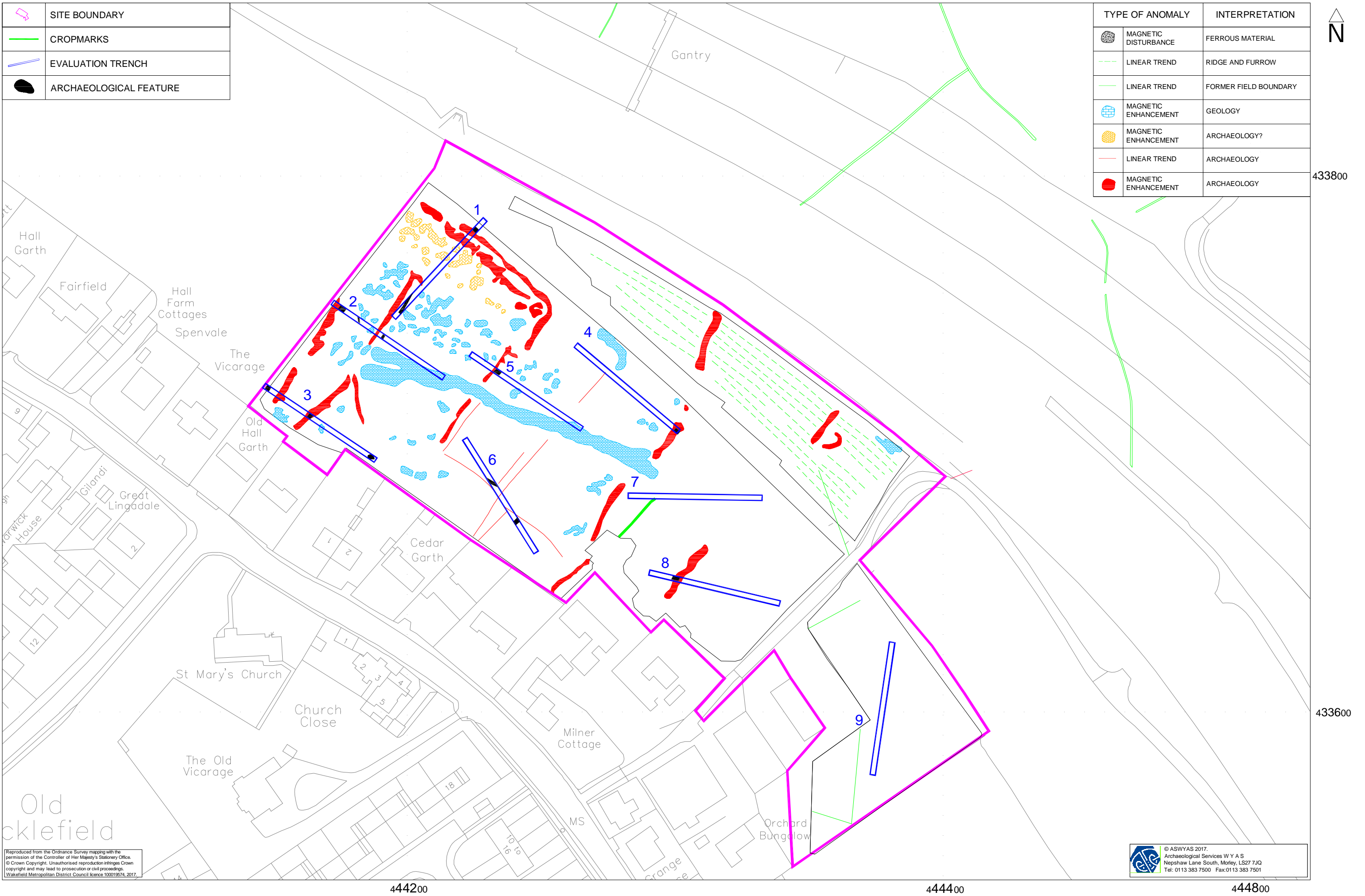

Fig. 2. Site plan showing trench locations and interpretation of magnetometer data (1:1250 @ A3)



Reproduced from the Ordnance Survey mapping with the permission of the Controller of Her Majesty's Stationery Office. © Crown Copyright. Unauthorised reproduction infringes Crown copyright and may lead to prosecution or civil proceedings. Wakefield Metropolitan District Council licence 100019574, 2017.

© ASWYAS 2017. Archaeological Services W Y A S. Nepshaw Lane South, Morley, LS27 7JQ. Tel: 0113 383 7500 Fax: 0113 383 7501

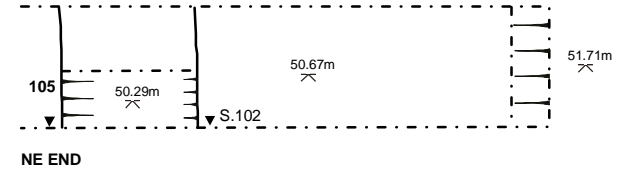
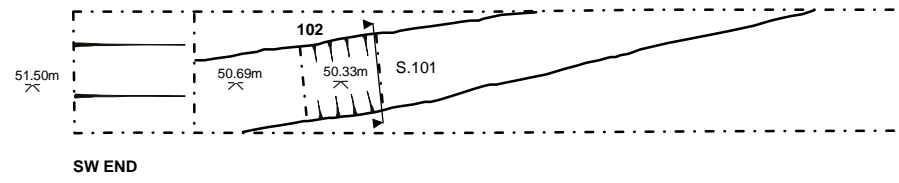
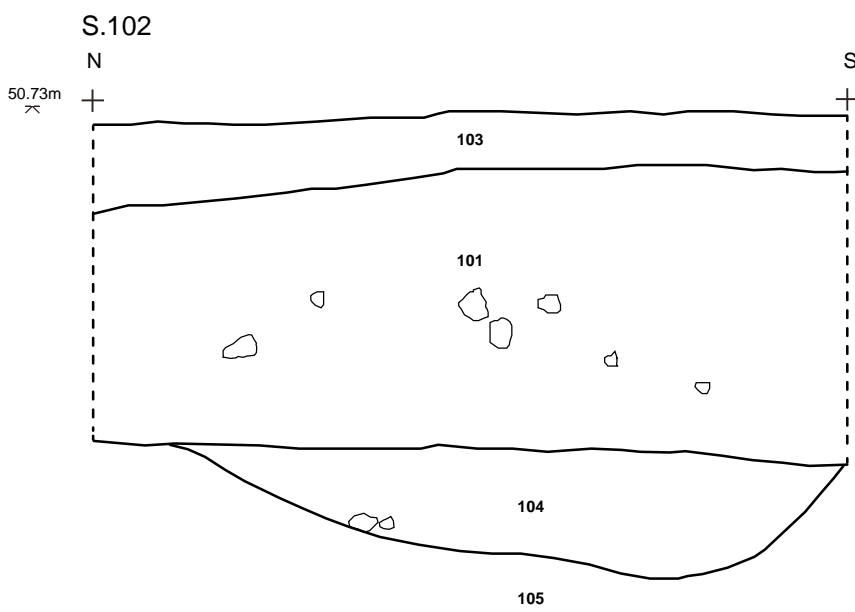
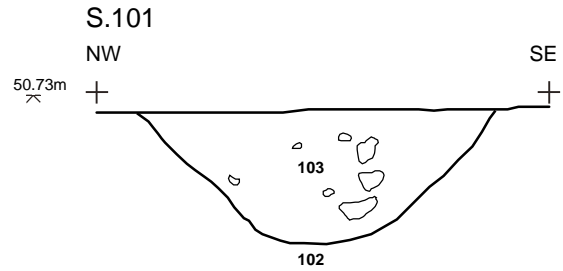

Fig. 3. Trench 1 feature plans and sections

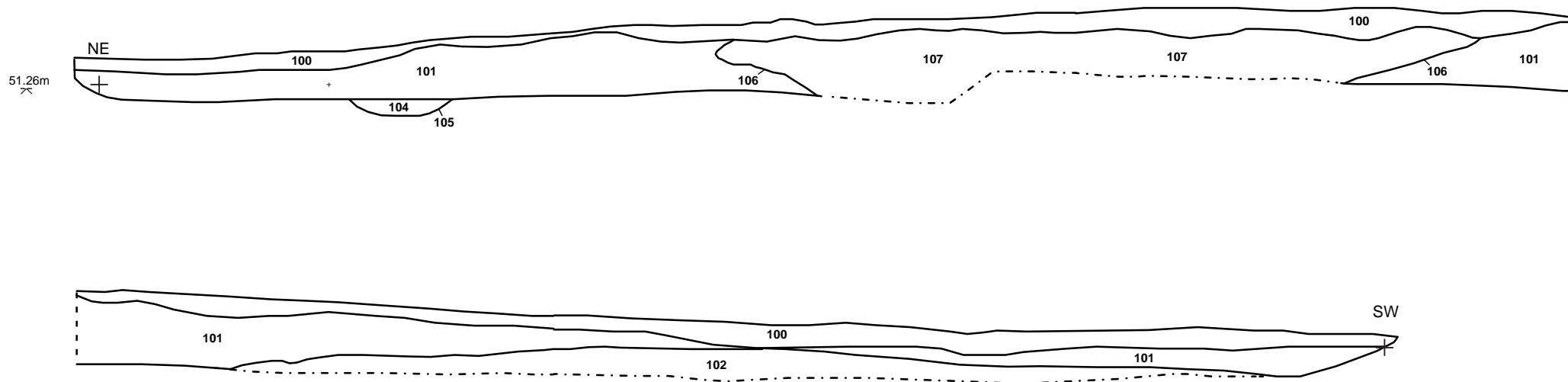

Fig. 4. North-west facing section of Trench 1

Section  
0 5m (1:100)

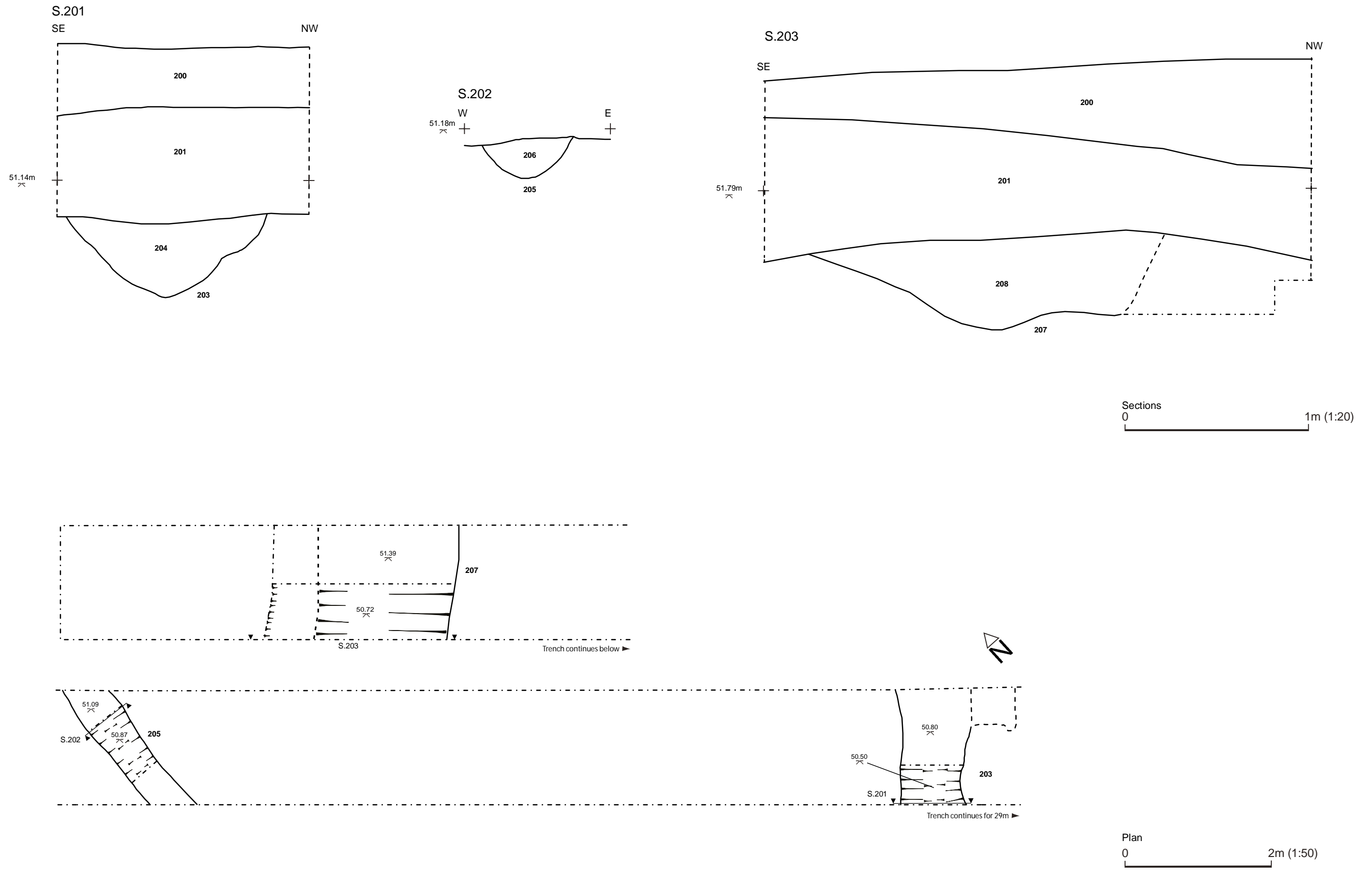

Fig. 5. Trench 2 plan and sections

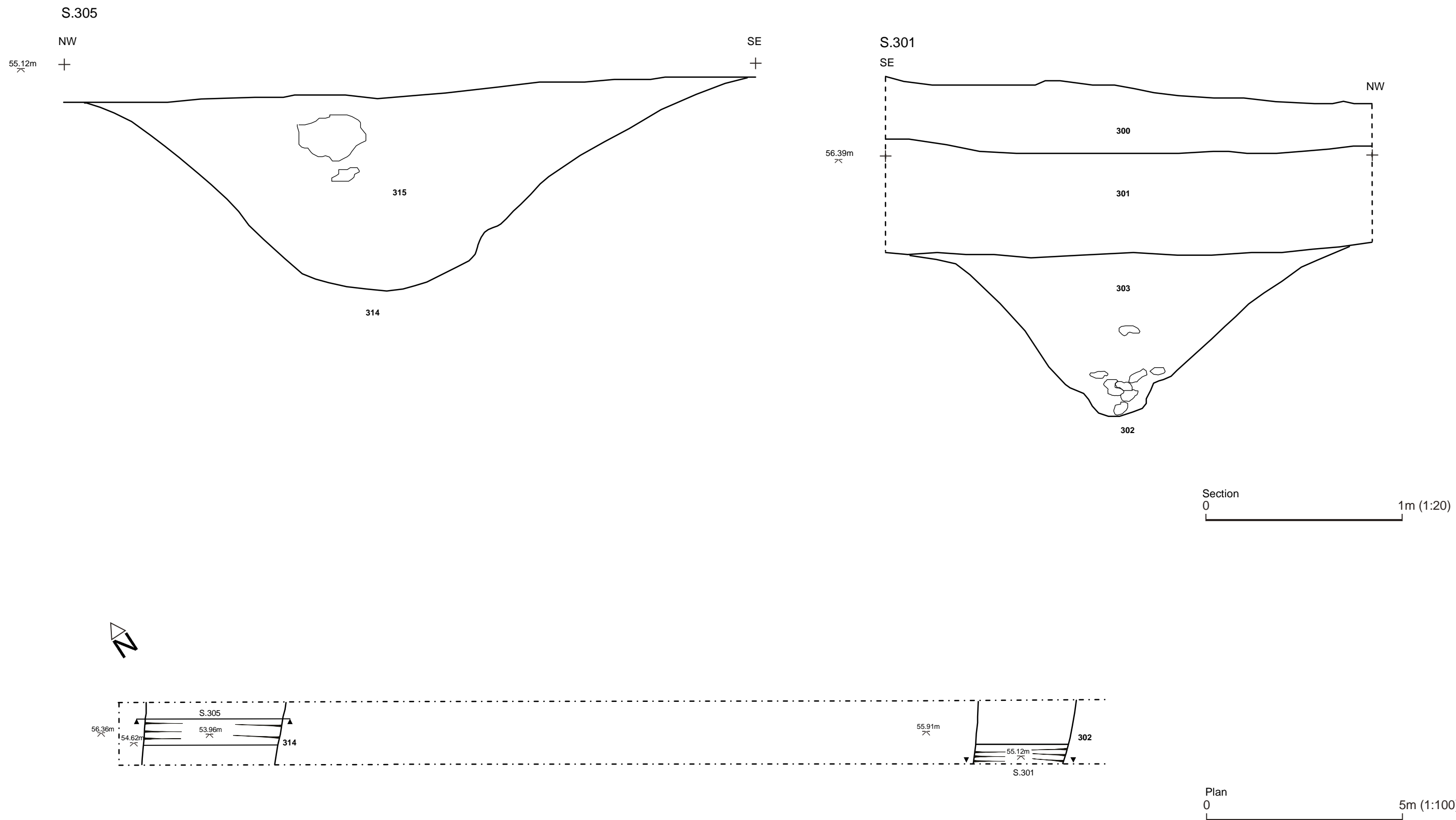

Fig. 6. Trench 3 NW end, plan and sections

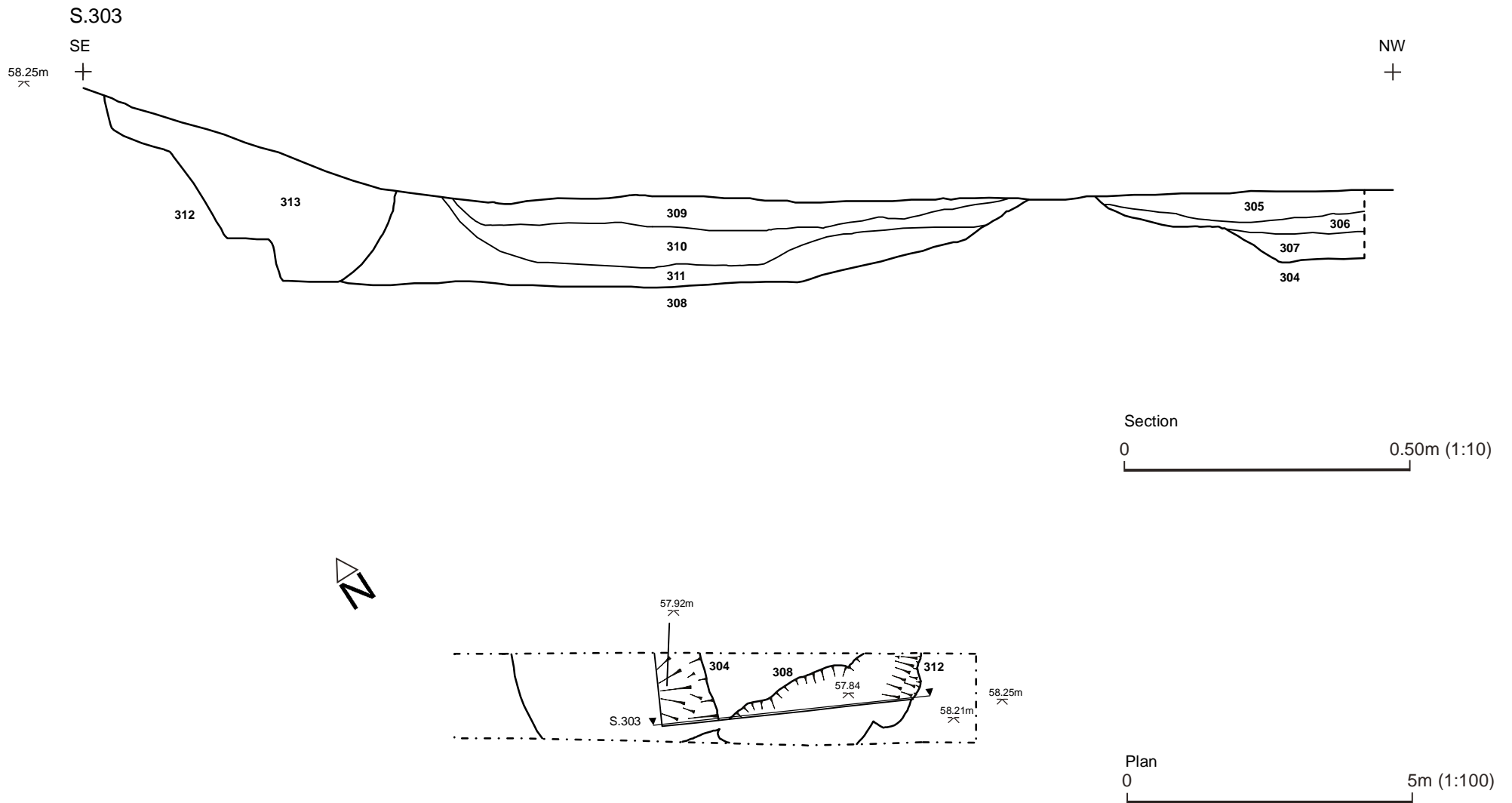

Fig. 7. Trench 3 SE end, plan and section

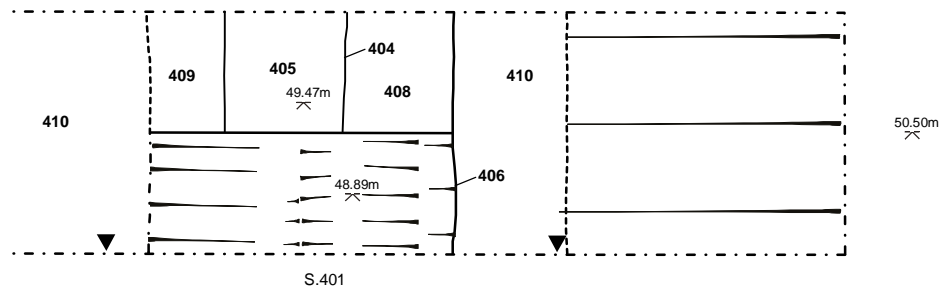
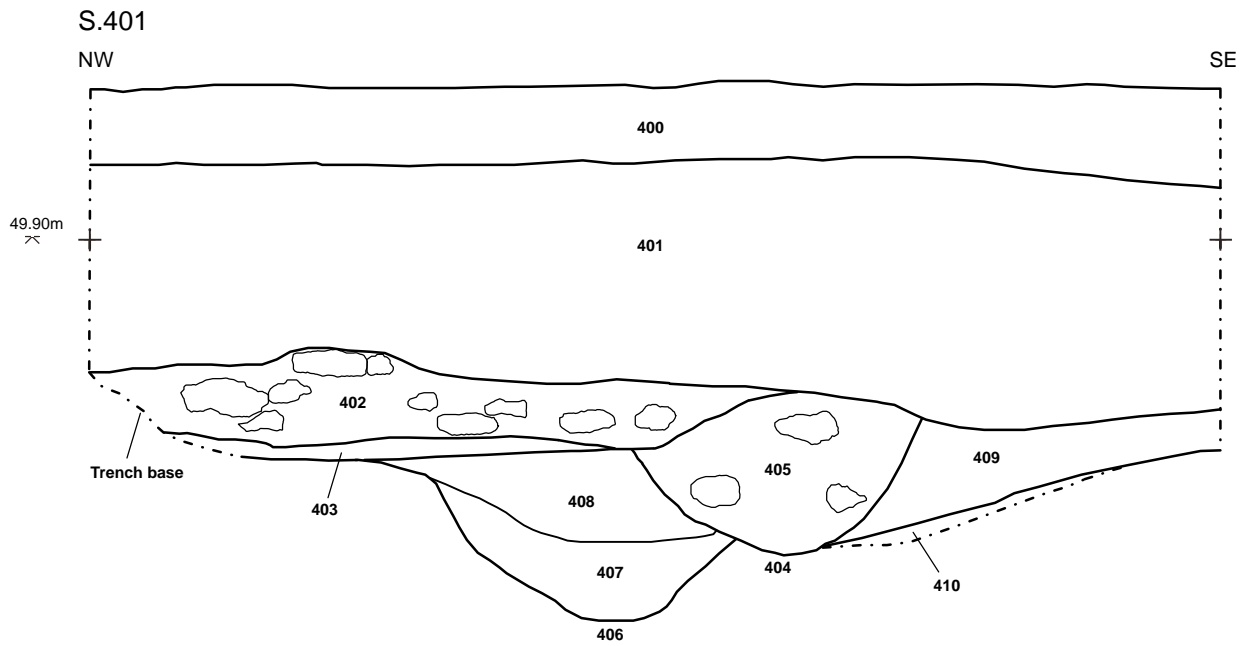

Fig. 8. Trench 4 plan and section

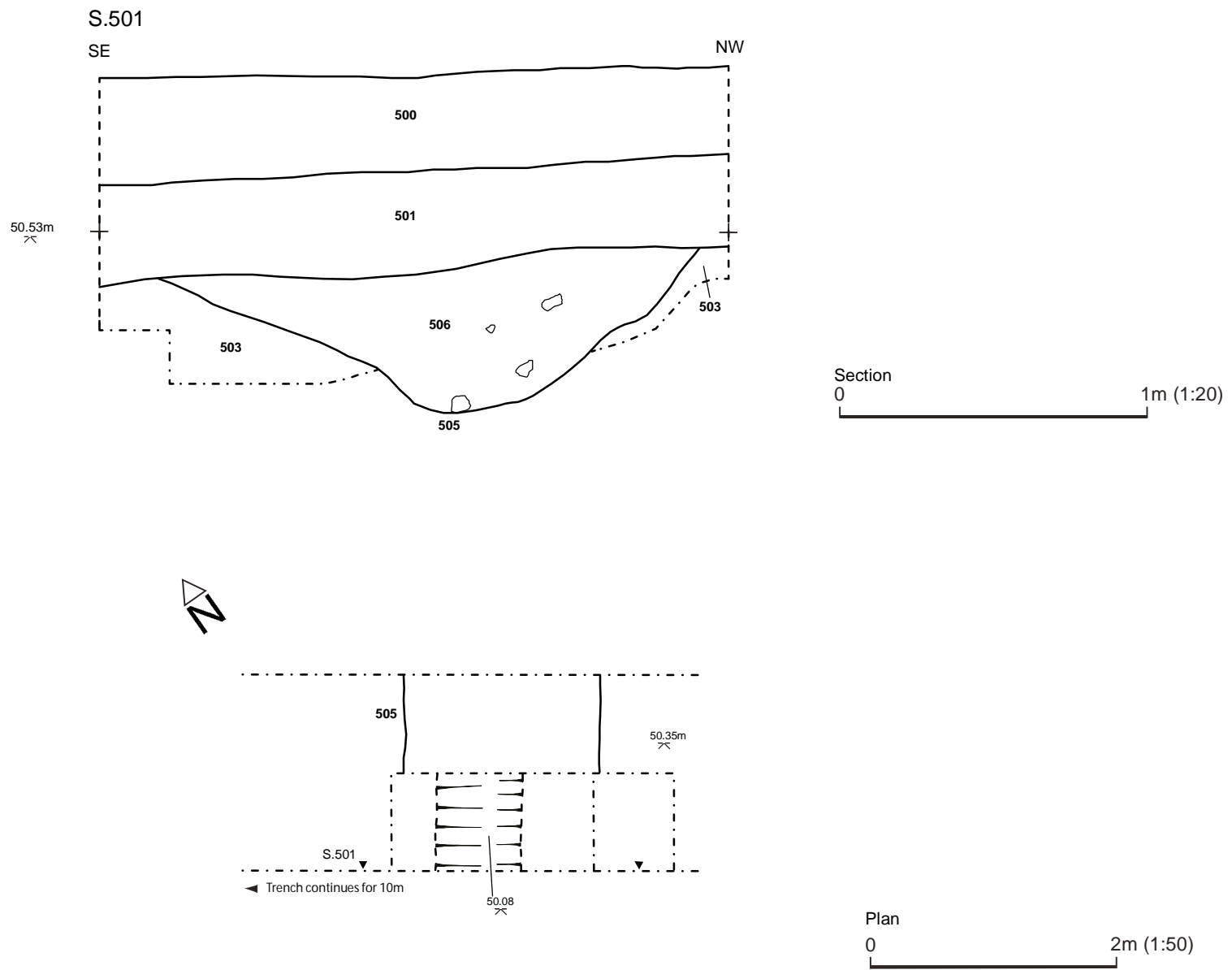

Fig. 9. Trench 5 plan and section



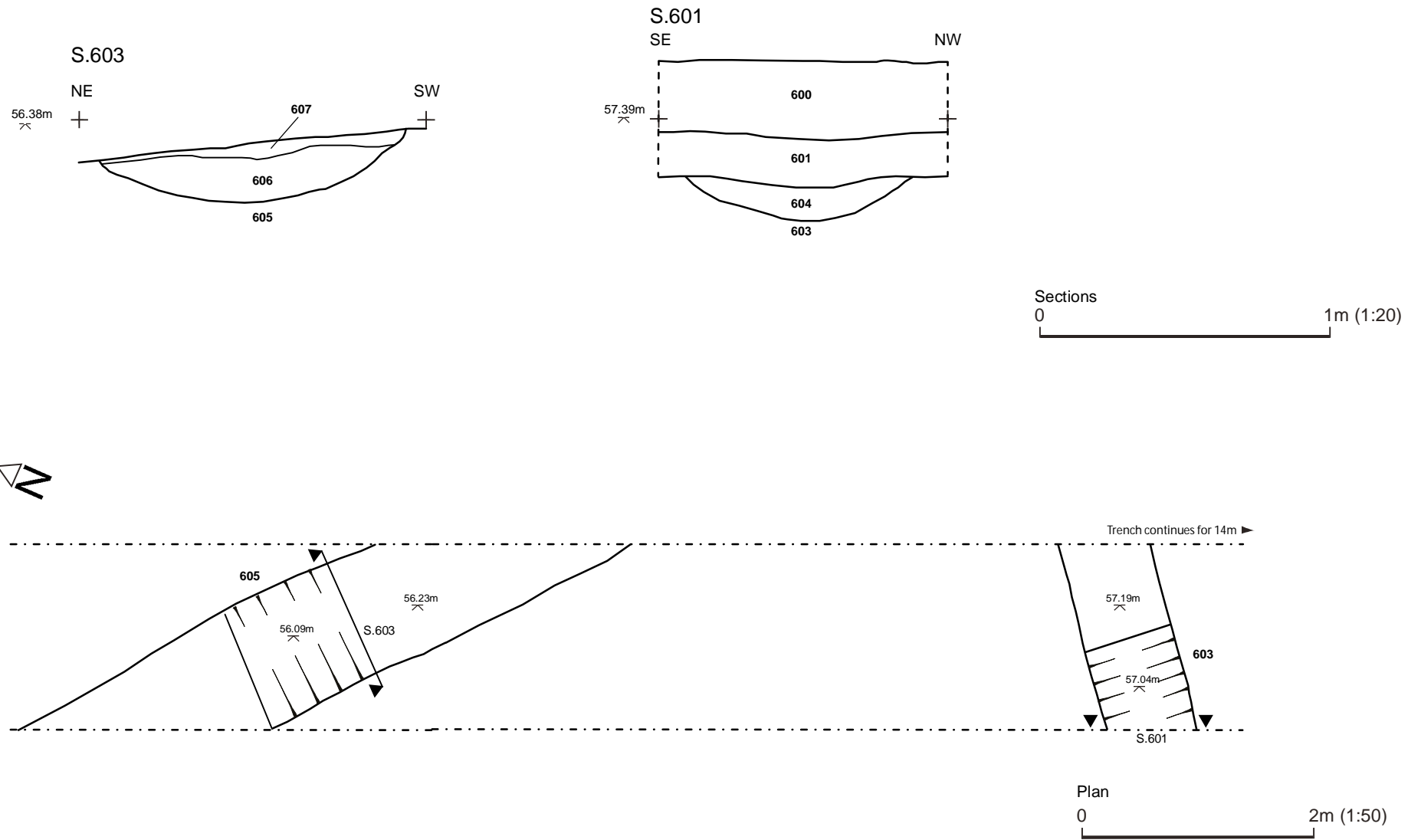

Fig. 10. Trench 6 plan and sections

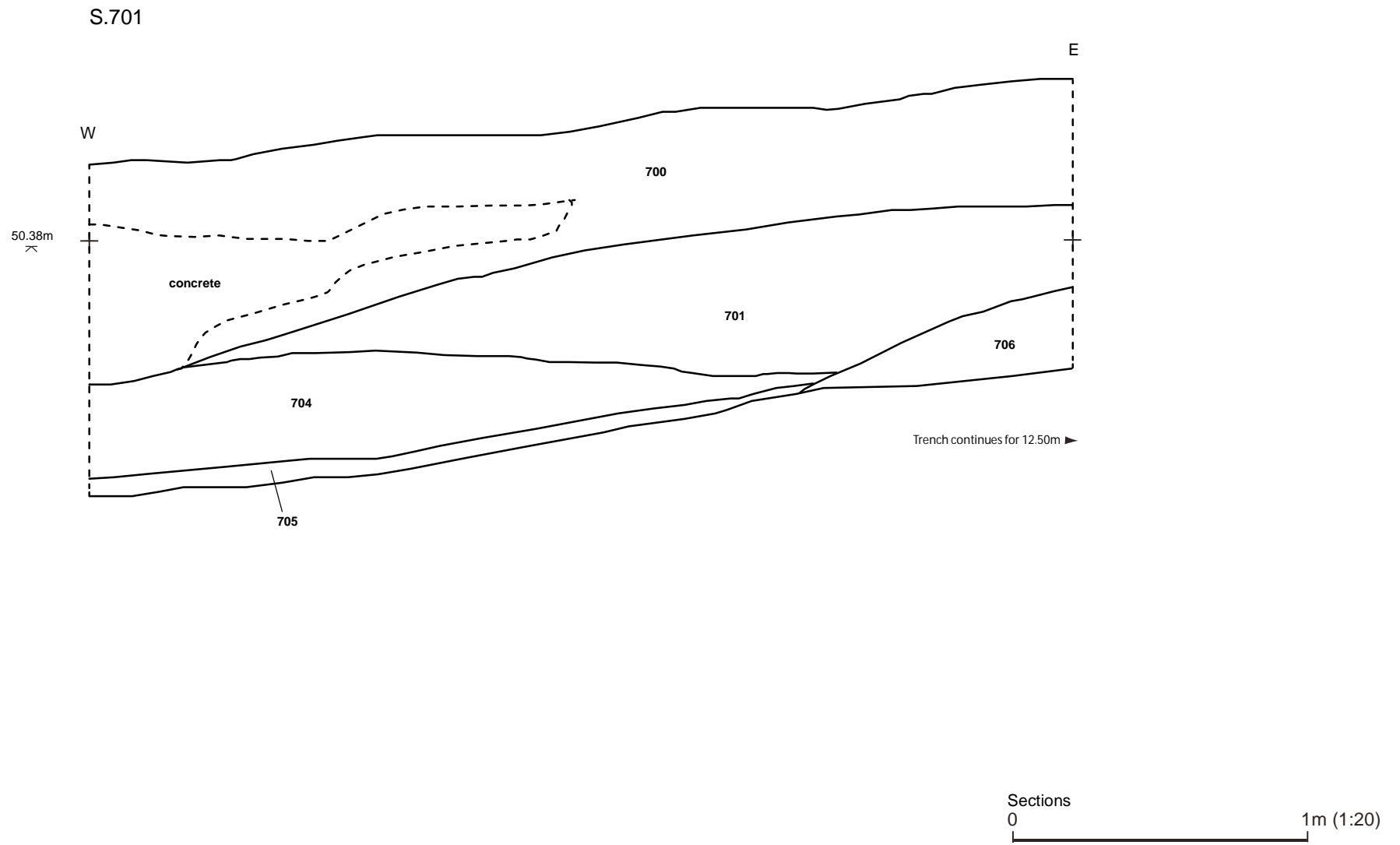

Fig. 11. North-facing sample section of Trench 7

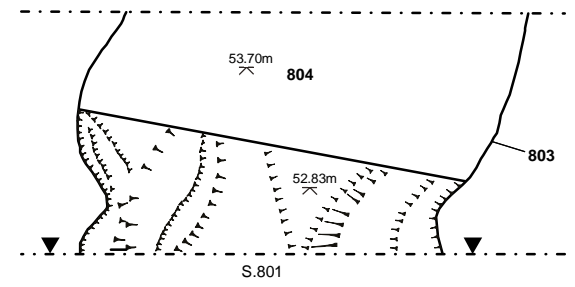
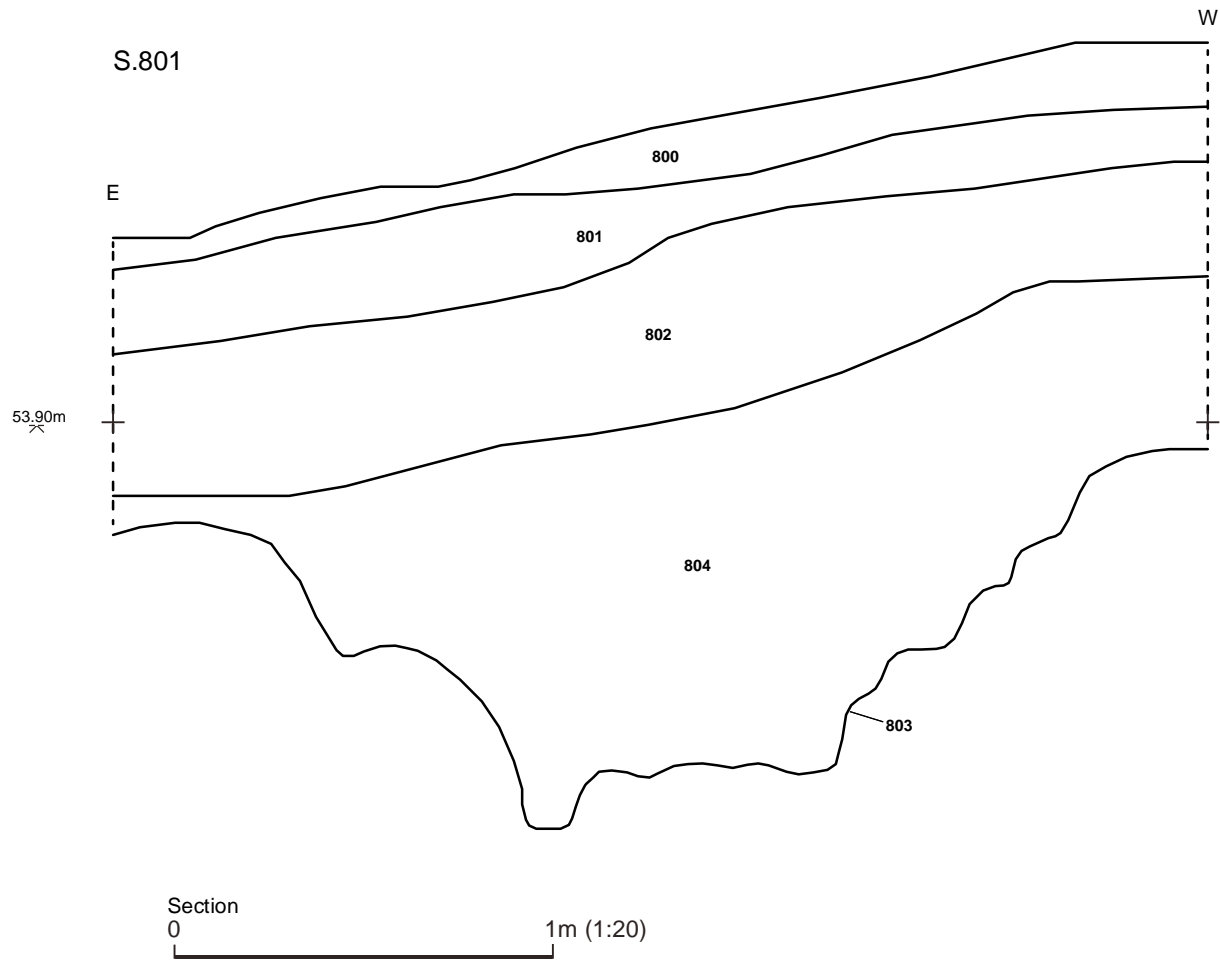

Fig. 12. Trench 8 plan and section



Fig. 13. Earthwork survey (1:1000 @ A3)

Reproduced from the Ordnance Survey mapping with the permission of the Controller of Her Majesty's Stationery Office.  
 © Crown Copyright. Unauthorised reproduction infringes Crown copyright and may lead to prosecution or civil proceedings.  
 Wakefield Metropolitan District Council licence 100019574 . 2017.

© ASWYAS 2017.  
 Archaeological Services W Y A S  
 Nephaw Lane South, Morley, LS27 7JQ  
 Tel: 0113 383 7500 Fax: 0113 383 7501



*Plate 1. Trench 1, looking north-east*



*Plate 2. Trench 2, looking north-west*



*Plate 3. Trench 4, looking north-east*



*Plate 4. Trench 5, looking north-west*



*Plate 5. Trench 6, looking south-east*



*Plate 6. Trench 7, looking east*



*Plate 7. Trench 8, looking east*



*Plate 8. North-facing section of Ditch 803*



*Plate 9. Trench 9, looking north*



*Plate 10. East-facing section of sondage in Trench 9*

**Appendix 1: Specification**



**WEST YORKSHIRE ARCHAEOLOGY ADVISORY SERVICE (WYAAS):  
SPECIFICATION FOR GEOPHYSICAL SURVEY, EARTHWORK SURVEY AND  
TRIAL TRENCHING TO EVALUATE ARCHAEOLOGICAL REMAINS IN ADVANCE  
OF DEVELOPMENT AT LAND OFF GREAT NORTH ROAD MICKLEFIELD  
(Revised 26/1/17)**

**SE 44262 33707**

**Specification prepared on behalf of Leeds City Council at the request of Nansi Rosenberg of Prospect Archaeology (Planning Application 13/02271/OT).**

## **1.0 Summary**

1.1 Archaeological work, consisting of geophysical survey, earthwork survey and trial trenching is proposed to help establish the archaeological significance of the above site prior to development for housing. Any work arising from the results of the evaluation will be covered by a further specification.

1.2 This specification has been prepared by the West Yorkshire Archaeology Advisory Service, the holders of the WY Historic Environment Record

NOTE: The requirements detailed in paragraphs 6.3, 6.4, 6.5, 6.6 and 9.1 are to be met by the archaeological contractor **prior** to the commencement of fieldwork by completing and returning the attached form to the WY Archaeology Advisory Service.

## **2.0 Site Location & Description**

Grid Reference (centred): **SE 44262 33707**

2.1 The irregularly shaped application site is located to the east of Old Micklefield, east of the route of the Great North Road and west of the modern A1(M). A small stream, the Sheep Dike runs north-west to south-east through the site dividing it into two parcels of land with 2/3rds to the west and 1/3<sup>rd</sup> to the east of the stream. The site slopes down from properties lining the Great North Road in the west to the “valley” of Sheep Dike in the east and is currently used as pasture.

2.2 The under lying geology is Dolomitised Limestone and Dolomite.

2.3 The site has an area of 2.9ha and is located in the historic township of Micklefield.

## **3.0 Planning Background**

3.1 An outline planning application has been made for residential development within the site (13/02271/OT). Based on information held by the West Yorkshire Historic Environment Record and desk based assessment by the developer’s agent the West Yorkshire Archaeology Advisory Service informed Leeds City Council that important archaeological remains may be affected by the proposed development. The WYAAS recommended a pre-determination archaeological evaluation was carried out to permit

a balanced judgement to be made on the significance of known and buried archaeological remains and the impact the development would have on these.

3.2 Depending upon the results obtained, additional archaeological work governed by separate specifications of work, may be required.

3.3 This specification has been prepared by the West Yorkshire Archaeology Advisory Service at the request of Nansi Rosenberg of Prospect Archaeology (Prospect House, Garden Lane, Sherburn-in-Elmet LS25 6AT Tel.: 01977 681885), to detail what is required to evaluate the site.

#### 4.0 **Archaeological Interest**

4.1 The application site lies in an area of known archaeological potential identified by aerial photography and archaeological excavation. Remains from the Bronze Age through Iron Age and Roman periods to medieval and post medieval periods are known to lie in the vicinity. Standing remains, in the form of grass covered earthworks are present in the northern part of the site (shown in solid red and green on figure 1), these may be medieval or post medieval in date (see below). The sites archaeological potential has been reviewed by the applicant's agent in a desk based assessment.

4.2 Late Prehistoric and Roman period settlement have been identified in the vicinity and in some cases excavated ahead of development. These sites generally take the form of small discrete farmsteads surrounded by a ditch and bank and comprising the buried remains of round houses, pits, hearths and postholes. A network of trackways and field boundaries lie between settlements. Landscapes of different periods overlap and are superimposed upon one another creating a complex palimpsest of settlement. Burial monuments are also known, such as ring ditches which are assumed to be ploughed out Bronze Age barrows. Individual and small groups of cremations and inhumation burials are also recorded.

4.3 Roman Ridge, the main north-to-south Roman Road lies c.2km to the west of Micklefield.

During the early medieval period the site lay in the Kingdom of Elmet. A village or settlement of *Miclanfield* is recorded in the possession of the Archbishop of York in 963 but Micklefield is not recorded in the Domesday Book of 1086. Whilst there is some evidence to suggest the village later developed as a medieval settlement this has not been proven by recent archaeological work.

However, the presence of evidence relating to both medieval cultivation in strip fields (ridge and furrow ploughing) and the earthworks standing in the northern part of the site shows there is potential for remains of the medieval or later periods to be present. These earthworks comprise an east-west bank with a more complex rectangular enclosure attached at its eastern end and aligned with the Sheep Dike. The assertion made by Wheeler in the late 19<sup>th</sup> century that the remains of buildings were found to the immediate north in Hall Garth further suggests medieval activity within the site (West Yorkshire Historic Environment Record PRN 2838).

The earthworks, which historic maps show extend beyond the site to the west, have not been fully characterised. It has been suggested that they may relate to a water powered corn mill. However, this assumption remains unproven and they may have fulfilled other agricultural roles requiring the control of the Sheep Dike. The creation of flood meadows, to promote early growth of meadow grass being one possible function, whilst the assumed water mill site may conceivably be a sheep wash.

4.4 The significance of the remains within the site can only be determined by archaeological fieldwork comprising geophysical survey, earthwork survey and trial trenching.

## 5. Aim of the Specified Work

5.1 The aim of the evaluation is to gather sufficient information to establish the extent, condition, character and date (as far as circumstances permit) of any archaeological features and deposits within the area of interest. The information gained will allow the Planning Authority to make a reasonable and informed decision on the impact of the development proposals and whether archaeological deposits should be preserved in-situ, or more appropriately, be recorded prior to destruction (whether this be a summary record from a salvage excavation or watching brief, or a detailed record from full open area excavation).

## 6. General Instructions

### 6.1 Health and Safety

6.1.1 The archaeologist on site will naturally operate with due regard for Health and Safety regulations. This work may require the preparation of a Risk Assessment of the site, in accordance with the Health and Safety at Work Regulations. The WYAAS and its officers cannot be held responsible for any accidents or injuries that may occur to outside contractors while attempting to conform to this specification. Any Health and Safety issues which may hinder compliance with this specification should be discussed with WYAAS at the earliest possible opportunity (e.g. working close to a water course) (see section 13.2).

### 6.2 Location of Services, etc.

6.2.1 The archaeological contractors will be responsible for locating any drainage pipes, service pipes, cables *etc.* which may cross any of the trench lines, and for taking the necessary measures to avoid disturbing such services.

### 6.3 Confirmation of Adherence to Specification

6.3.1 Prior to the commencement of *any work*, the archaeological contractor must confirm adherence to this specification in writing to the WYAAS, or state (with reasons) any proposals to vary the specification. Should the contractor wish to vary the specification, then written confirmation of the agreement of the West Yorkshire Archaeology Advisory Service to any variations is required prior to work commencing. Unauthorised variations are made at the sole risk of the contractor. **Modifications presented in the form of a re-written specification/project design will not be considered by the WYAAS.** Any technical queries arising from the specification detailed below should be addressed to the WYAAS *without delay*.

## 6.4 Confirmation of Timetable and Contractors' Qualifications

6.4.1 Prior to the commencement of *any work*, the archaeological contractor **must** provide WYAAS **in writing** with:

- a projected timetable for the site work;
- details of the staff structure and numbers;
- names and CVs of key project members (the project manager, site supervisor, any proposed specialists, sub-contractors *etc.*),

6.4.2 All project staff provided by the archaeological contractor must be suitably qualified and experienced for their roles. The timetable should be adequate to allow the work to be undertaken to the appropriate professional standard, subject to the ultimate judgement of WYAAS.

## 6.5 Notification

6.5.1 WYAAS should be provided with **as much notice as possible in writing** (and certainly not less than one week) of the intention to start work. A copy of the archaeological contractor's risk assessment of the site should accompany the notification.

6.5.2 The Leeds City Museums curator, Katherine Baxter (Leeds Museum Discovery Centre Carlisle Road, Hunslet, Leeds, LS10 1LB Tel.: 0113 2305492; email: [katherine.baxter@leeds.gov.uk](mailto:katherine.baxter@leeds.gov.uk)) must be contacted prior to commencing fieldwork.

6.5.3 Historic England's Regional Science Adviser, Andy Hammon, should also be notified of the intention to commence fieldwork. (Tel.: 01904 601983; email: [Andy.Hammon@HistoricEngland.org.uk](mailto:Andy.Hammon@HistoricEngland.org.uk)).

## 6.6 Documentary Research

6.6.1 Prior to the commencement of *fieldwork* the archaeological contractor should study the desk based assessment prepared for *Land at Manor Farm, Micklefield, W Yorks*, prepared by Prospect Archaeology, in order to gain an overview of the archaeological/historical background of the site and environs. In addition to providing a knowledge base for the work in hand, the results of this assessment may be incorporated into the contractor's report where they are considered to contribute to that report, but any extraneous material should be omitted. A copy is held by the WY HER. Please note that the HER makes a charge for consultations of a commercial nature. The results of this exercise should be used to inform the whole project. A formal desk-based report is not required and the results of this stage of work should be incorporated in the final report.

## 7.0 Earthwork and Geophysical Survey Methodology

Geophysical survey contractors are expected to adhere to the English Heritage *Geophysical Survey in Archaeological Field Evaluation* (2008), but also see para. 7.2 and 7.3 below.

### 7.1 Earthwork Survey

7.1.1 Detailed survey will be carried out on the earthwork bank, which forms the southern boundary Hall Garth, and the earthwork enclosure to the east of this running parallel with the Sheep Dike (shown within the blue polygon on figure 1). These remains are currently considered to be the site of a medieval water mill and water control features. These remains occupy an area of c. 0.9ha.

7.1.2 The detailed earthwork survey should be carried out using tapes and level, an electronic total station or GPS and should be tied into the national grid and Ordnance Survey datum. Site boundaries should be plotted in order to link the site to the O.S base map. All identified earthworks should be surveyed, plotting the top and bottom of slope; in the case of linear features each end should also be plotted. Where earthwork monuments are encountered, observed bank heights and ditch depths should be recorded; profiles across the earthworks should be drawn. The total station or GPS data can then be used to produce a hachured earthwork survey plan.

7.1.3 Horizontal survey interval will vary according to the complexity of the earthworks being surveyed, sufficient to recover an accurate record of the character of the earthworks. The interval between points will normally be no more than 1m on the upstanding earthworks. However, where earthworks have strongly directional components, as is the case with upstanding ridge-and-furrow, a greater spacing in the direction parallel to those components will suffice. In areas of particular complexity (including the areas requiring detailed survey above), hand-drawn detail plans will be produced, to complement the surveyed data.

7.1.4 Each earthwork component is to be given a unique identifier code or number. Each individual monument will be located on an O.S. base map and given a brief text description (including dimensions and a description of the monuments condition and any relationships with associated monuments).

7.1.5 Archaeological features, exposed archaeological deposits and finds should also be recorded, with an approximate grid reference, but no attempt should be made to excavate these. In the unlikely event of locating surface finds, these may be collected for dating purposes.

**7.1.6 Record photographs should be taken where possible. These should be colour slides or good quality digital photography using a film or exposed to show good contrast in green, scales should be included in photographs. Where earthworks are to be photographed a 30m white tape should be laid over the earthwork so as to show its profile.**

7.1.7 The earthwork Survey results will be presented as a hachured and annotated drawing at an appropriate scale of not less than 1:500. A profile or profiles of the upstanding remains should also be produced at a scale of 1:50 to illustrate their form. Levels, to the Ordnance Survey datum, should be included on major or important features. The finished drawing must be checked against the earthworks in the field.

## **7.2 Geophysical Survey**

7.2.1 The entire area of the proposed development will be subject to a magnetic (gradiometer) survey using cart mounted sensors. The data will be collected at sub-

meter traverse intervals with a minimum of four samples per meter and located using GPS.

7.2.3 The use of hand held gradiometers will only be permitted where site conditions prevent the use of a cart system. The WYAAS must be made aware of this and agree the variation prior to the survey taking place.

### 7.3 Data Presentation

The results of the gradiometer survey should be processed and the results then discussed at a meeting between the contractor and the WYAAS (the client may also wish to attend). The results of the gradiometer survey should be presented in at least two different formats at a minimum 1:500 scale, one of which must be an X/Y trace plot. There must also be an accompanying interpretation drawing at an appropriate scale.

## 8.0 Trenching Methodology

### 8.1 Trench Size and Placement (Figure 1)

8.1.1 Trial Trenching will not be permitted until the results of the earthwork survey have been presented to the WYAAS.

8.1.2 The trial trenching will involve the excavation of 900m<sup>2</sup> of evaluation trenching comprising 9 2m x 50m trench, which can be machine-opened. The contractor should also allow for a contingency amount of 290m<sup>2</sup>. The use of the contingency will depend upon the results obtained in the initial trial trenching. The use of the contingency will be at the decision of the WYAAS, whose decision will be issued in writing, if necessary in retrospect after site discussions.

The location of trenches will be agreed in writing by the contractor and the WYAAS following the publication of the results of the earthwork and geophysical surveys. All significant archaeological anomalies are to be tested as are significant blank areas. An indicative trenching plan is included as figure 1.

Trench No	Dimensions (m)	Area (m <sup>2</sup> )
1	50 x 2	100
2	50 x 2	100
3	50 x 2	100
4	50 x 2	100
5	50 x 2	100
6	50 x 2	100
7	50 x 2	100
8	50 x 2	100
9	50 x 2	100

Total site area: **22300m<sup>2</sup>** Total area of trenching: **900m<sup>2</sup>**

Contingency trenching: **200m<sup>2</sup>**

### 8.2 Method of Excavation

8.2.1 The trial trenches may be opened and the topsoil and recent overburden removed down to the first significant archaeological horizon in successive level spits

of a **maximum** 0.2m. thickness, by the use of an appropriate machine using a wide toothless ditching blade. **Under no circumstances should the machine be used to cut arbitrary trenches down to natural deposits.** Any machine work must be carried out under direct archaeological supervision and the machine halted if significant archaeological deposits are encountered. The top of the first significant archaeological horizon may be exposed by the machine, but must then be cleaned by hand and inspected for features and then dug by hand.

8.2.2 No archaeological deposits should be entirely removed unless this is unavoidable in achieving the objectives of this evaluation, although **all** features identified are expected to be half-sectioned and the **full** depth of archaeological deposits must be assessed. All trenches are to be the stated dimensions at their base.

8.2.3 All artefacts are to be retained for processing and analysis except for unstratified 20<sup>th</sup> and 21<sup>st</sup> century material, which may be noted and discarded. Finds will be stored in secure, appropriate conditions following the guidelines in First Aid for Finds (3<sup>rd</sup> edition).

### **8.3 Method of Recording**

8.3.1 The trenches are to be recorded according to the normal principles of stratigraphic excavation. The stratigraphy of each area is to be recorded, even when no archaeological deposits have been identified.

8.3.2 Section drawings (at a minimum scale of 1:20) must include heights A.O.D. Plans (at a minimum scale of 1:50) must include O.D. spot heights for all principal strata and any features. At least one representative/sample section of each trench edge will be drawn and illustrated in the report. These sections should show a representative and complete sequence of deposits from the modern ground surface to the natural geology. Where archaeological features are present then the full trench section should be recorded and illustrated in the report. In trenches containing no archaeological features a representative profile will be drawn.

8.3.3 The actual areas of excavation and all archaeological (and possibly archaeological) features should be accurately located on a site plan and recorded by photographs, scale drawings and written descriptions sufficient to permit the preparation of a detailed archive and report on the material. The trench locations, as excavated, will be accurately surveyed, tied into the O.S. National Grid and located on an up-to-date 1:1250 O.S. map base.

8.3.4 Except where otherwise requested, black and white photography using orthodox monochrome chemical development should be used. Film should be no faster than ISO400. Slower films should be used where possible as their smaller grain size yields higher definition images. Technical Pan (ISO 25), Pan-F (ISO50), FP4 (ISO125) and HP5 (ISO400) are recommended. The use of dye-based films such as Ilford XP2 and Kodak T40CN is unacceptable due to poor archiving qualities. Black and white photography should be supplemented by colour photography; this should be in transparency format (i.e. slides or digital photography as an acceptable alternative, see paragraph 8.3.5 below).

8.3.55 Digital photography: As an alternative to colour transparency photography, good quality digital photography may be supplied, using cameras with a minimum resolution of 10 megapixels. Digital photography should follow the guidance given by Historic England in Digital Image Capture and File Storage: Guidelines for Best Practice, July 2015. Note that conventional black and white print photography is still required and constitutes the permanent record. Digital images will only be acceptable as an alternative to colour slide photography if each image is supplied in both JPEG and TIFF versions. The latter as an uncompressed 8-bits per channel TIFF version 6 file of not less than 25Mbs (See section 2.3 of the Historic England guidance). The contractor must include metadata embedded in the TIFF file. The metadata must include the following: the commonly used name for the site being photographed, the relevant centred OS grid coordinates for the site to at least six figures, the relevant township name, the date of photograph, the subject of the photograph, the direction of shot and the name of the organisation taking the photograph. **Any digital images are to be supplied to WYAAS on gold CDs by the archaeological contractor accompanying the hard copy of the report.**

#### 8.4 Use of Metal Detectors

8.4.1 Spoil heaps are to be scanned for non-ferrous metal artefacts using a metal detector capable of making this discrimination, operated by an experienced metal detector user (if necessary, operating under the supervision of the contracting archaeologist). Modern artefacts are to be noted but not retained (19<sup>th</sup>-century material and earlier should be retained and identified in the report as unstratified or metal detector finds.)

8.4.2 If a non-professional archaeologist is to be used to carry out the metal-detecting, a formal agreement of their position as a sub-contractor working under direction must be agreed in advance of their use on site. This formal agreement will apply whether they are paid or not. To avoid financial claims under the Treasure Act a suggested wording for this formal agreement with the metal detectorist is: "In the process of working on the archaeological investigation at [*location of site*] between the dates of [*insert dates*], [*name of person contributing to project*] is working under direction or permission of [*name of archaeological organisation*] and hereby waives all rights to rewards for objects discovered that could otherwise be payable under the Treasure Act 1996."

#### 8.5 Environmental Sampling Strategy

8.5.1 Bulk samples must be taken from **all** securely stratified deposits using a strategy which combines systematic and judgement sampling, but which also follows the methodologies outlined in the English Heritage (2011) 'Environmental Archaeology: A Guide to the Theory and Practice of Methods, from Sampling and Recovery to Post-excavation (Second Edition)' guidance

8.5.2 Samples for specialist environmental analysis and scientific dating (soil profiles, archaeomagnetic dating, dendrochronology etc.) should be taken if suitable material is encountered during the excavation. The Historic England Science Advisor should be consulted (Dr Andy Hammon, tel.: 01904 601983, email: Andy.Hammon@HistoricEngland.org.uk.) and provision should be made for an appropriate specialist(s) to visit the site, take samples and discuss the sampling strategy, if necessary.



## **8.6 Conservation Strategy**

8.6.1 A conservation strategy must be developed in collaboration with a recognised laboratory. All finds must be assessed in order to recover information that will contribute to an understanding of their deterioration and hence preservation potential, as well as identifying potential for further investigation. Furthermore, all finds must be stabilised and packaged in accordance with the requirements of the receiving museum. As a guiding principle, only artefacts of a “displayable” quality would warrant full conservation, but metalwork and coinage from stratified contexts would be expected to be x-rayed if necessary, and conservation costs should also be included as a contingency.

## **8.7 Human Remains**

8.7.1 Should human remains be discovered they must initially be left *in-situ*, covered and protected. WYAAS will be notified at the earliest opportunity. If removal is necessary the remains must be excavated archaeologically in accordance with the *Guidance for Best Practice for Treatment of Human Remains Excavated from Christian Burial Grounds in England* published by English Heritage (2005), a valid Ministry of Justice licence, if appropriate, and any local environmental health regulations.

## **8.8 Treasure Act**

8.8.1 The terms of the Treasure Act 1996, as amended, must be followed with regard to any finds that might fall within its purview. Any finds must be removed to a safe place and reported to the local coroner as required by the procedures as laid down in the “Code of Practice”. Where removal cannot be effected on the same working day as the discovery, suitable security measures must be taken to protect the finds from theft.

## **8.9. Unexpectedly Significant or Complex Discoveries**

8.9.1 Should there be unexpectedly significant or complex discoveries made that warrant, in the professional judgement of the archaeologist on site, more detailed recording than is appropriate within the terms of this specification, then the archaeological contractor should urgently contact the WYAAS with the relevant information to enable them to resolve the matter with the developer.

## **8.10 Access/Monitoring Arrangements**

8.10.1 The representative of the WYAAS will be afforded access to the site at any reasonable time. It is usual practice that the visit is arranged in advance, but this is not always feasible. The WYAAS’ representative will be provided with a site tour and an overview of the site by the senior archaeologist present and should be afforded the opportunity to view all trenches, any finds made that are still on site, and any records not in immediate use. It is anticipated that the records of an exemplar context that has previously been fully recorded will be examined. Any observed deficiencies during the site visit are to be made good to the satisfaction of the WYAAS’ representative, by the next agreed site meeting. Access is also to be afforded at any reasonable time to Historic England’s Archaeological Science Advisor.

8.10.2 Please note that WYAAS now make a charge for site monitoring visits. An invoice will be raised on the archaeological contractor. Two site monitoring visit will be charged for this project. Please contact us for the current charge.

## **9. Excavation Archives Deposition.**

**9.1** Before commencing any fieldwork, the archaeological contractor must contact the relevant District museum archaeological curator to determine the museum's requirements for the deposition of an excavation archive. In this case the contact is Katherine Baxter (Leeds Museum Discovery Centre Carlisle Road, Hunslet, Leeds, LS10 1LB Tel.: 0113 2305492; email: [katherine.baxter@leeds.gov.uk](mailto:katherine.baxter@leeds.gov.uk)). Agreement for deposition should be confirmed in writing by the archaeological contractor; this correspondence is to be copied to the WYAAS.

**9.2** It is the policy of Leeds Museums to accept complete excavation archives, including primary site records and research archives and finds, from all excavations carried out in the District that it serves.

**9.3** It is the responsibility of the archaeological contractor to endeavour to obtain consent of the landowner, in writing, to the deposition of finds with Leeds Museums.

**9.4** It is the responsibility of the archaeological contractor to meet Leeds Museums' requirements with regard to the preparation of excavation archives for deposition.

## **10. Post-Excavation Analysis and Reporting**

### **10.1 Finds and Samples**

10.1.1 On completion of the fieldwork, any samples taken shall be processed and any finds shall be cleaned, identified, assessed/analysed, dated (if possible), marked (if appropriate) and properly packed and stored in accordance with the requirements of national guidelines.

10.1.2 Samples should be processed for the recovery of artefactual material, animal/fish/human bones, industrial residues (including hammerscale), shell, molluscs, charcoal and mineralised plant remains as a minimum. 'Specialist' samples (e.g. monoliths, cores, plant/invertebrate macrofossils) should be processed separately as appropriate.

10.1.3 Material suitable for scientific dating (e.g. charcoal) should be identified to species and assessed for suitability by an environmental specialist prior to submission to a dating laboratory. Any human remains submitted for C14 dating should also have carbon ( $\delta 13C$ ) and nitrogen isotope analysis carried out by the radiocarbon laboratory.

10.1.4 All finds and biological material must be analysed by a qualified and experienced specialist.

10.1.5 Following identification, finds of 20<sup>th</sup> & 21<sup>st</sup> century date should be noted, quantified and summarily described, but can then be discarded if appropriate. All finds which are of 19<sup>th</sup> century or earlier date should be retained and archived.

### 10.3 Field Archive

10.3.1 A fully indexed field archive shall be compiled consisting of all primary written documents, plans, sections, photographic negatives and a complete set of labelled photographic prints/slides. Standards for archive compilation and transfer should conform to those outlined in *Archaeological Archives – a guide to best practice in creation, compilation, transfer and curation* (Archaeological Archives Forum, 2007). The contractor should also take account of any additional requirements imposed by the recipient museum (see section 9.1 above). An index to the field archive is to be deposited with the West Yorkshire Archaeology Advisory Service (preferably as an appendix in the report).

10.3.2 Prints may be executed digitally from scanned versions of the film negatives, and may be manipulated to improve print quality (but **not** in a manner which alters detail or perspective). **All digital prints, including those presented in the report, must be made on paper and with inks which are certified against fading or other deterioration for a period of 75 years or more when used in combination. If digital printing is employed, the contractor must supply details of the paper/inks used in writing to the WY Archaeology Advisory Service, with supporting documentation indicating their archival stability/durability.** Written confirmation that the materials are acceptable must have been received from the WYAAS prior to the commencement of work on site.

10.3.3 The original archive is to accompany the deposition of any finds, providing the landowner agrees to the deposition of finds in a publicly accessible archive (see para. 8.4 above). In the absence of this agreement the field archive (less finds) is to be deposited with the West Yorkshire Archaeology Advisory Service.

### 10.4 Report Format and Content

10.4.1 A report should be produced, which should include background information on the need for the project, a description of the methodology employed, and a full description and interpretation of results produced. It is not envisaged that the report is likely to be published, but it should be produced with sufficient care and attention to detail to be of academic use to future researchers.

10.4.2 Location plans should be produced at a scale which enables easy site identification and which depicts the full extent of the site investigated (a scale of 1:50,000 is not regarded as appropriate unless accompanied by a more detailed plan or plans). Earthwork plans should be provided at a scale of 1:500, additional plans and profiles should be at an appropriate recognised scale to show the detail recorded (see 7.18 above). Site plans should be at an appropriate scale showing trench layout (as dug), features located and, where possible, predicted archaeological deposits. Upon completion of each evaluation trench all sections containing archaeological features will be drawn. Section drawings (at a minimum scale of 1:20) must include heights O.D. Plans (at a minimum scale of 1:50) must include O.D. spot heights for all principal strata and any features.

10.4.3 Where no archaeological deposits are encountered at least one representative section detailing the soil profile will be illustrated in the report and titled as such.

10.4.5 Artefact analysis is to include the production of a descriptive catalogue, quantification by context and discussion/interpretation if warranted, with finds critical for dating and interpretation illustrated.

10.4.5 Environmental analysis is to include identification of the remains, quantification by context, discussion/interpretation if warranted, and a description of the processing methodology. Radiocarbon results must be presented in full (laboratory sample number, conventional radiocarbon age, delta C13 value, calibration programme). Copies of the laboratory-issued dating certificates must be included as an appendix to the report.

10.4.6 Details of the style and format of the report are to be determined by the archaeological contractor, but should include a full bibliography, a quantified index to the site archive, and, as an appendix, a copy of this specification.

## **10.5 Summary for Publication**

10.5.1 The attached summary sheet should be completed and submitted to the WYAAS for inclusion in the summary of archaeological work in West Yorkshire to be published on WYAAS' website.

## **10.6 Publicity**

If the project is to be publicised in any way (including media releases, publications etc.), then it is expected that the WYAAS will be given the opportunity to consider whether it wishes its collaborative role to be acknowledged, and if so, the form of words used will be at the WYAAS' discretion.

## **10.6 Consideration of Appropriate Mitigation Strategy**

11.6.1 The report should not give a judgement on whether preservation or further investigation is considered appropriate, but should provide an interpretation of results, placing them in a local and regional, and if appropriate, national context. However, a client may wish to separately commission the contractor's view as to an appropriate treatment of the resource identified.

## **11. Report Submission and Deposition with the HER**

**11.1 A hard copy of the report (plus a digital facsimile copy on gold disk) is to be supplied directly to the WYAAS, in a timely manner to allow further work, if necessary, to be scheduled and the planning application to be determined in an informed manner, and certainly within a period of two months** following completion of fieldwork so as not to delay a planning decision to be made, unless specialist reports are awaited. In the latter case a revised date should be agreed with the WYAAS. Completion of this project and advice from WYAAS on an appropriate mitigation strategy are dependant upon receipt by WYAAS of a satisfactory report which has been prepared in accordance with this specification. Any comments made by WYAAS in response to the submission of an unsatisfactory report will be taken into account and will result in the reissue of a suitably edited report to all parties, within a timescale which has been agreed with WYAAS.

11.2 The report will be supplied on the understanding that it will be added to the West Yorkshire Historic Environment Record where it will be publicly accessible once

deposited unless confidentiality is explicitly requested, in which case it will become publicly accessible six months after deposition.

11.3 Copyright - Please note that by depositing this report, the contractor gives permission for the material presented within the document to be used by the WYAAS, in perpetuity, although The Contractor retains the right to be identified as the author of all project documentation and reports as specified in the *Copyright, Designs and Patents Act 1988* (chapter IV, section 79). The permission will allow the WYAAS to reproduce material, including for commercial use by third parties, with the copyright owner suitably acknowledged.

11.4 A copy of the final report (in .pdf format) shall also be supplied to Historic England's Science Advisor (Andy.Hammon@HistoricEngland.org.uk).

11.5 The West Yorkshire HER supports the Online Access to Index of Archaeological Investigations (OASIS) project. The overall aim of the OASIS project is to provide an online index to the mass of archaeological grey literature that has been produced as a result of the advent of large-scale developer funded fieldwork. The archaeological contractor must therefore complete the online OASIS form at <http://ads.ahds.ac.uk/project/oasis/>. Contractors are advised to contact the West Yorkshire HER officer prior to completing the form. Once a report has become a public document by submission to or incorporation into the HER, the West Yorkshire HER may place the information on a web-site. Please ensure that you and your client agree to this procedure in writing as part of the process of submitting the report to the case officer at the West Yorkshire HER.

## 12. General Considerations

### 12.1 Authorised Alterations to Specification by Contractor

12.1.1 It should be noted that this specification is based upon records available in the West Yorkshire Historic Environment Record and on a brief examination of the site by the WYAAS. Archaeological contractors submitting tenders should carry out an inspection of the site prior to submission. If, on first visiting the site or at any time during the course of the recording exercise, it appears in the archaeologist's professional judgement that

- i) a part or the whole of the site is not amenable to recording as detailed above, and/or
- ii) an alternative approach may be more appropriate or likely to produce more informative results, and/or

then it is expected that the archaeologist will contact WYAAS as a matter of urgency. If contractors have not yet been appointed, any variations which the WYAAS considers to be justifiable on archaeological grounds will be incorporated into a revised specification, which will then be re-issued to the developer for redistribution to the tendering contractors. If an appointment has already been made and site work is ongoing, WYAAS will resolve the matter in liaison with the developer and the Local Planning Authority.

### 12.2 Unauthorised Alterations to Specification by Contractor

12.2.1 It is the archaeological contractor's responsibility to ensure that they have obtained WYAAS' consent in writing to any variation of the specification prior to the commencement of on-site work or (where applicable) prior to the finalisation of the tender. Unauthorised variations may result in WYAAS being unable to recommend determination of the planning application to the Local Planning Officer based on the archaeological information available and are therefore made solely at the risk of the contractor.

### **12.3 Technical Queries**

Similarly, any technical queries arising from the specification detailed above, should be addressed to WYAAS without delay.

### **12.4 Valid Period of Specification**

This specification is valid for a period of one year from date of issue. After that time it may need to be revised to take into account new discoveries, changes in policy or the introduction of new working practices or techniques.

**West Yorkshire Archaeology Advisory Service  
David Hunter**

**December 2016**

**Historic Environment Record  
West Yorkshire Archaeology Advisory Service  
Registry of Deeds  
Newstead Road  
Wakefield  
WF1 2DE**

**Telephone: (01924) 306798  
Fax: (01924) 306810  
E-mail: david.hunter@wyjs.org.uk**

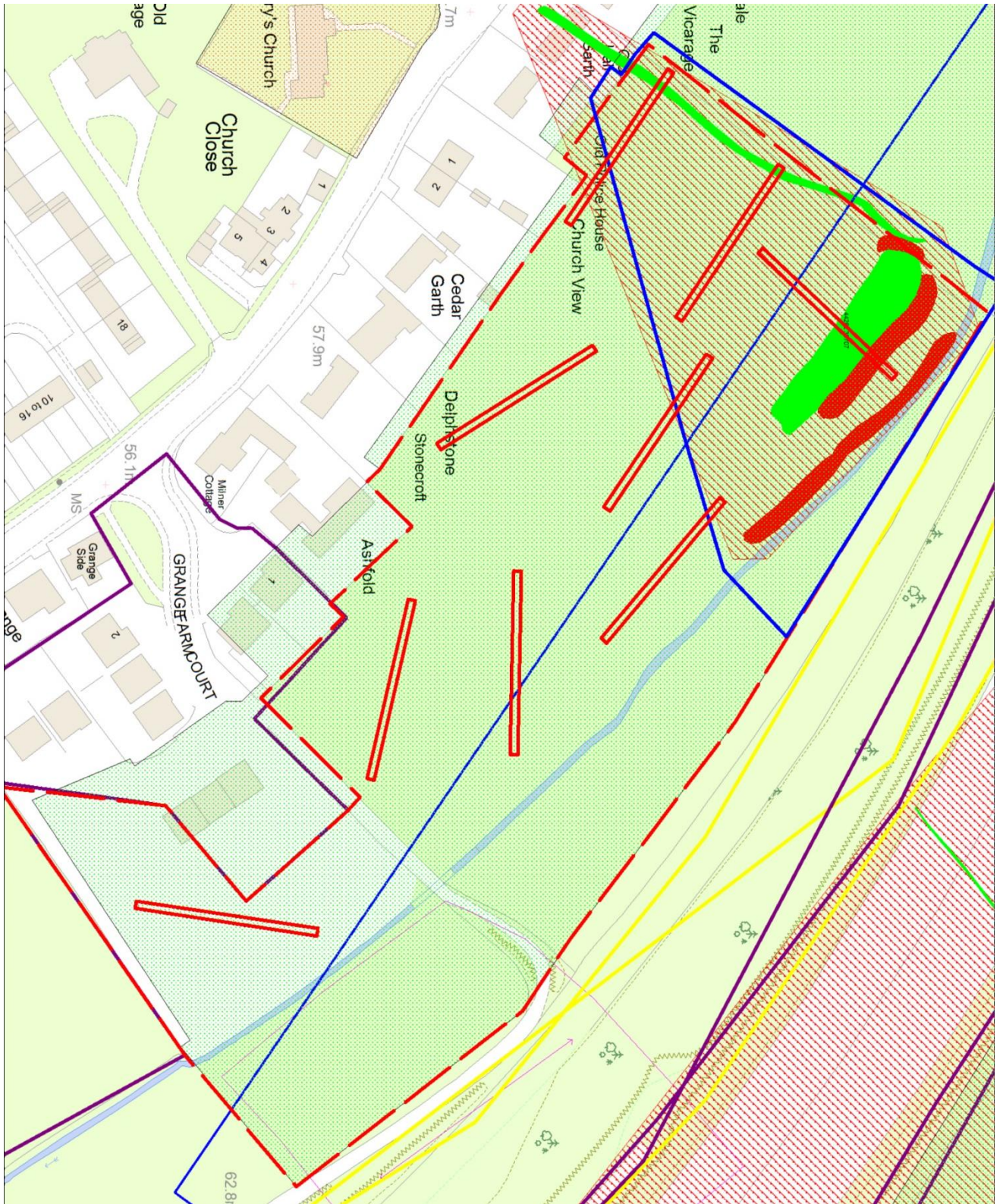

Figure 1. Site Location Plan and Trench Locations

**Appendix 2: Inventory of primary archive**

Phase	File/Box No	Description	Quantity
Evaluation	File no.1	Context register sheets	7
		Daily record sheet	8
		Trench sheets	9
		Context cards	44
		Photo record sheets	1
		Digital photo record sheets	2
		Sample register	1
		Permatrace	12



## Appendix 3: Trench tables

### Trench 1

General Description					Orientation	SW-NE
This trench contained two ditches at each end of the trench both of which were observed as geophysical anomalies. A large deposit of modern construction debris (106) was found in the centre of the trench extending beyond the safe working depth of 1.20m and cut through the subsoil.					Average Depth (m)	0.80-1.20
					Width (m)	1.60
					Length (m)	50.00
Contexts						
Context	Type	Length (m)	Width (m)	Depth (m)	Description	
100	Layer	-	-	0.35	Topsoil – dark brown sandy-silt	
101	Layer	-	-	0.40	Subsoil – mid-orangey-brown sandy-clay	
102	Cut	1.0 (ex.)	1.20	0.50	Cut of N-S aligned ditch	
103	Fill	1.0 (ex.)	1.20	0.50	Fill of Ditch 102 – dark reddish-brown sandy-clay	
104	Fill	1.0 (ex.)	2.00	0.30	Fill of Ditch 105 – dark reddish-brown sandy-clay	
105	Fill	1.0 (ex.)	2.00	0.30	Cut of SW-NE aligned ditch	
106	Cut	-	13.50	1.30	Cut of modern demolition dump	
107	Fill	-	13.50	1.30	Fill of 106 – concrete and modern demolition debris	

### Trench 2

General Description					Orientation	SE-NW
Trench 2 contained three ditches. All but the south-eastern feature (207) correlates with a geophysical anomaly.					Average Depth (m)	1.13
					Width (m)	1.60
					Length (m)	50.00
Contexts						
Context	Type	Length (m)	Width (m)	Depth (m)	Description	
200	Layer	-	-	0.40	Topsoil – dark brown sandy-silt	
201	Layer	-	-	0.73	Subsoil – mid-orangey-brown sandy-clay	

202	Layer	-	-	-	Natural – limestone bedrock
203	Cut	0.56 (ex.)	1.10	0.50	Cut of SW-NE aligned ditch
204	Fill	0.56 (ex.)	1.10	0.50	Fill of Ditch 203 – dark reddish-brown sandy-clay
205	Cut	1.00 (ex.)	0.50	0.37	Cut of N-S aligned ditch
206	Fill	1.00 (ex.)	0.50	0.37	Fill of Ditch 205 – dark reddish-brown sandy-clay
207	Cut	1.60 (ex.)	2.00	0.51	Cut of SW-NE aligned ditch
208	Fill	1.60 (ex.)	2.00	0.51	Fill of Ditch 207 – light reddish-brown sandy-clay

### Trench 3

<b>General Description</b>				<b>Orientation</b>	SE-NW
Trench 3 contained two ditches and a series of intercutting pits at the north-western end. Ditch 302 correlates roughly with a geophysical anomaly running through the centre of the trench.				<b>Average Depth (m)</b>	0.93
				<b>Width (m)</b>	1.60
				<b>Length (m)</b>	50.00
<b>Contexts</b>					
<b>Context</b>	<b>Type</b>	<b>Length (m)</b>	<b>Width (m)</b>	<b>Depth (m)</b>	<b>Description</b>
300	Layer	-	-	0.30	Topsoil – dark brown sandy-silt
301	Layer	-	-	0.63m	Subsoil – mid-orangey-brown sandy-clay
302	Cut	0.50 (ex.)	2.30	0.83	Cut of SW-NE aligned ditch
303	Fill	0.50 (ex.)	2.30	0.83	Fill of Ditch 302 – dark reddish-brown sandy-clay
304	Cut	3.90	>1.55	0.26	Cut of pit
305	Fill	1.20 (ex.)	0.94 (ex.)	0.10	Fill of 304 – mid-orangey-brown silty-clay
306	Fill	1.20 (ex.)	0.10	0.07	Fill of 304 – dark greyish-brown charcoal and silty-clay
307	Fill	1.20 (ex.)	0.48	0.09	Fill of 304 - light orangey-brown silty-clay
308	Cut	2.22	>1.40	0.30	Cut of pit

309	Fill	1.95	1.40 (ex.)	0.13	Fill of 308 – light greyish-brown silty-clay
310	Fill	1.95	1.40 (ex.)	0.15	Fill of 308 – dark greyish-brown silty-clay
311	Fill	1.30	1.40 (ex.)	0.02-0.33	Fill of 308 – dark orangey-brown silty-clay
312	Cut	1.02	>1.30	0.40	Cut of pit
313	Fill	1.02	>1.30	0.40	Fill of 312 – mid-greyish-brown
314	Cut	0.75 (ex.)	3.55	0.87	Cut of SW-NE aligned ditch
315	Fill	0.75 (ex.)	3.55	0.87	Fill of 314 - dark reddish-brown sandy-clay
316	Layer	-	-	-	Natural – limestone bedrock

## Trench 4

<b>General Description</b>				<b>Orientation</b>	SE-NW
Trench 4 contained a series of intercutting ditches at its south-eastern end.				<b>Average Depth (m)</b>	1.10
				<b>Width (m)</b>	2.00
				<b>Length (m)</b>	50.00
<b>Contexts</b>					
<b>Context</b>	<b>Type</b>	<b>Length (m)</b>	<b>Width (m)</b>	<b>Depth (m)</b>	<b>Description</b>
400	Layer	-	-	0.22m	Topsoil – dark brown sandy-silt
401	Layer	-	-	0.50m	Subsoil – mid-orangey-brown sandy-silt
402	Layer	>1.90	>1.60	0.25	Redeposited limestone, gravel and sand
403	Layer	?	1.60	0.05	Clay and sand possibly associated with 408
404	Cut	0.80 (ex.)	0.75	0.51	Cut of SW-NE ditch – re-cut of Ditch 406
405	Fill	0.80 (ex.)	0.75	0.51	Fill of 404 - dark reddish-brown sandy-clay
406	Cut	0.80 (ex.)	0.80	0.21	Cut of SW-NE ditch
407	Fill	0.80 (ex.)	0.80	0.21	Fill of 406 – dark orangey-brown sandy-clay

408	Fill	0.80 (ex.)	0.90	0.27	Fill of 406 – dark brown sandy-clay
409	Layer	-	-	0.51	Colluvial layer
410	Layer	-	-	-	Natural – limestone bedrock, gravels and sand

## Trench 5

<b>General Description</b>				<b>Orientation</b>	SE-NW
Trench 5 contained a single ditch, cut into colluvial deposits				<b>Average Depth (m)</b>	0.85
				<b>Width (m)</b>	1.60
				<b>Length (m)</b>	50.00
<b>Contexts</b>					
<b>Context</b>	<b>Type</b>	<b>Length (m)</b>	<b>Width (m)</b>	<b>Depth (m)</b>	<b>Description</b>
500	Layer	-	-	0.30m	Topsoil – dark brown sandy-silt
501	Layer	-	-	0.50m	Subsoil – dark brownish-red sandy-silt
502	Layer	-	-	0.40	Alluvium – dark brownish-red silty-clay
503	Layer	-	-	0.40	Colluvium – mid-yellowish-brown
504	Layer	-	-	-	Natural – limestone bedrock, gravel and sands
505	Cut	0.80 (ex.)	1.75	0.55	Cut of SW-NE aligned ditch
506	Fill	0.80 (ex.)	1.75	0.55	Fill of 505 - dark reddish-brown sandy-clay

## Trench 6

<b>General Description</b>					<b>Orientation</b>	SE-NW
Trench 6 contained two ditches which may correlate with smaller geophysical anomalies running through the trench.					<b>Average Depth (m)</b>	0.40
					<b>Width (m)</b>	1.60
					<b>Length (m)</b>	50.00
<b>Contexts</b>						
<b>Context</b>	<b>Type</b>	<b>Length (m)</b>	<b>Width (m)</b>	<b>Depth (m)</b>	<b>Description</b>	
600	Layer	-	-	0.20m	Topsoil – dark brown sandy-silt	
601	Layer	-	-	0.20m	Subsoil – mid-orangey-brown sandy-silt	
602	Layer	-	-	-	Natural – sandy-clayey	
603	Cut	1.80	0.80	0.11	Cut of SW-NE aligned ditch	
604	Fill	1.80	0.80	0.11	Fill of 603 – dark yellowish-brown sandy-clay	
605	Cut	7.00	1.06	0.22	Cut of NW-SE aligned ditch	
606	Fill	7.00	1.06	0.16	Fill of 605 - dark yellowish-brown clayey-silt	
607	Fill	-	0.22	0.06	Fill of 605 - dark brownish-black sandy-silt	

## Trench 7

<b>General Description</b>					<b>Orientation</b>	E-W
Trench 7 did not contain any archaeological features but a series of natural and modern deposits were recorded in section.					<b>Average Depth (m)</b>	0.86-1.35
					<b>Width (m)</b>	1.60
					<b>Length (m)</b>	50.00
<b>Contexts</b>						
<b>Context</b>	<b>Type</b>	<b>Length (m)</b>	<b>Width (m)</b>	<b>Depth (m)</b>	<b>Description</b>	
700	Layer	-	-	0.15	Topsoil – dark grey sandy-silt	
701	Layer	-	-	0.35	Subsoil – mid-reddish-brown sandy-clay	
702	Layer	-	-	0.43	Whitish sandy-clay, concrete rubble-filled layer	

703	Layer	-	-	0.60	Compacted rubble layer
704	Layer	-	-	0.40	Alluvial clays
705	Layer	-	-	0.10	Colluvial sands and clays
706	Layer	-	-	-	Natural – weathered limestone bedrock

## Trench 8

<b>General Description</b>				<b>Orientation</b>	E-W
Trench 8 contained a single ditch which correlates with a geophysical anomaly.				<b>Average Depth (m)</b>	0.50
				<b>Width (m)</b>	1.60
				<b>Length (m)</b>	50.00
<b>Contexts</b>					
<b>Context</b>	<b>Type</b>	<b>Length (m)</b>	<b>Width (m)</b>	<b>Depth (m)</b>	<b>Description</b>
800	Layer	-	-	0.17m	Topsoil – dark brown sandy-silt
801	Layer	-	-	0.29m	Subsoil – mid-orangey-brown sandy-silt
802	Layer	-	-	0.40	Mixed dark grey and sandstone layer
803	Cut	0.50-0.90 (ex.)	2.40	1.87	Cut of N-S aligned ditch
804	Fill	0.50-0.90 (ex.)	2.40	1.87	Fill of 803 – dark orangey-brown silty-clay
805	Layer	-	-	-	Natural – weathered limestone bedrock

## Trench 9

<b>General Description</b>				<b>Orientation</b>	N-S
Trench 9 contained no archaeological features. A series of made ground deposits were found at the surface, covering the natural soil horizons. This sequence was investigated in a sondage at the southern end of the trench.				<b>Average Depth (m)</b>	0.50
				<b>Width (m)</b>	1.60
				<b>Length (m)</b>	50.00
<b>Contexts</b>					
<b>Context</b>	<b>Type</b>	<b>Length (m)</b>	<b>Width (m)</b>	<b>Depth (m)</b>	<b>Description</b>
900	Layer	-	-	0.15	Topsoil and turf
901	Layer	-	-	0.60	Crushed limestone made ground

902	Layer	-	-	0.60	Rubble made ground
903	Layer	-	-	0.30	Buried topsoil – dark brown sandy-silt
904	Layer	-	-	0.50	Buried subsoil – mid-orangey-brown sandy-silt
905	Layer	-	-	-	Natural – weathered limestone bedrock

## Bibliography

- Buckland, P.C., Dolby, M.J., Hayfield, C. and Magilton, J.R., 1979, *The medieval pottery industry at Hallgate, Doncaster*. Doncaster Museum and Art Gallery.
- Cumberpatch, C., 2004, *South Yorkshire / North Derbyshire Medieval Ceramics Reference Collection*. Archaeology Data Service (doi: 10.5284/1000242)
- French, D. H., 1971, An Experiment in Water Sieving. *Anatolian Studies* 21 59-64.
- Goulding, B., 2016, Land off Great North Road, Micklefield, West Yorkshire: Geophysical Survey. Archaeological Services WYAS unpublished report. 2923
- Mainman, A. and Jenner, A., 2013, *Medieval pottery from York*. The Archaeology of York- The Pottery **16/9**. Council for British Archaeology/York Archaeological Trust
- Roberts, I., Cumberpatch, C., Young, J., Ixer, R. and Hughes, M., 2013, *A Stamford Ware Pottery Kiln in Pontefract. Excavations at Simpson's Malt, Pontefract, West Yorkshire*. Archaeology Data Service (doi:10.5284/1012479)
- Schweingruber, F. H., 1990, *Anatomy of European Woods*. Paul Haupt Publishers Berne and Stuttgart.
- Stace, C., 1997, *New Flora of the British Isles*. 2nd Edition Cambridge University Press.
- Zohary, D. and Hopf, M., 2000, *Domestication of Plants in the Old World*. 3rd Edition Oxford University Press.



AREAS OF LEVEL GROUND

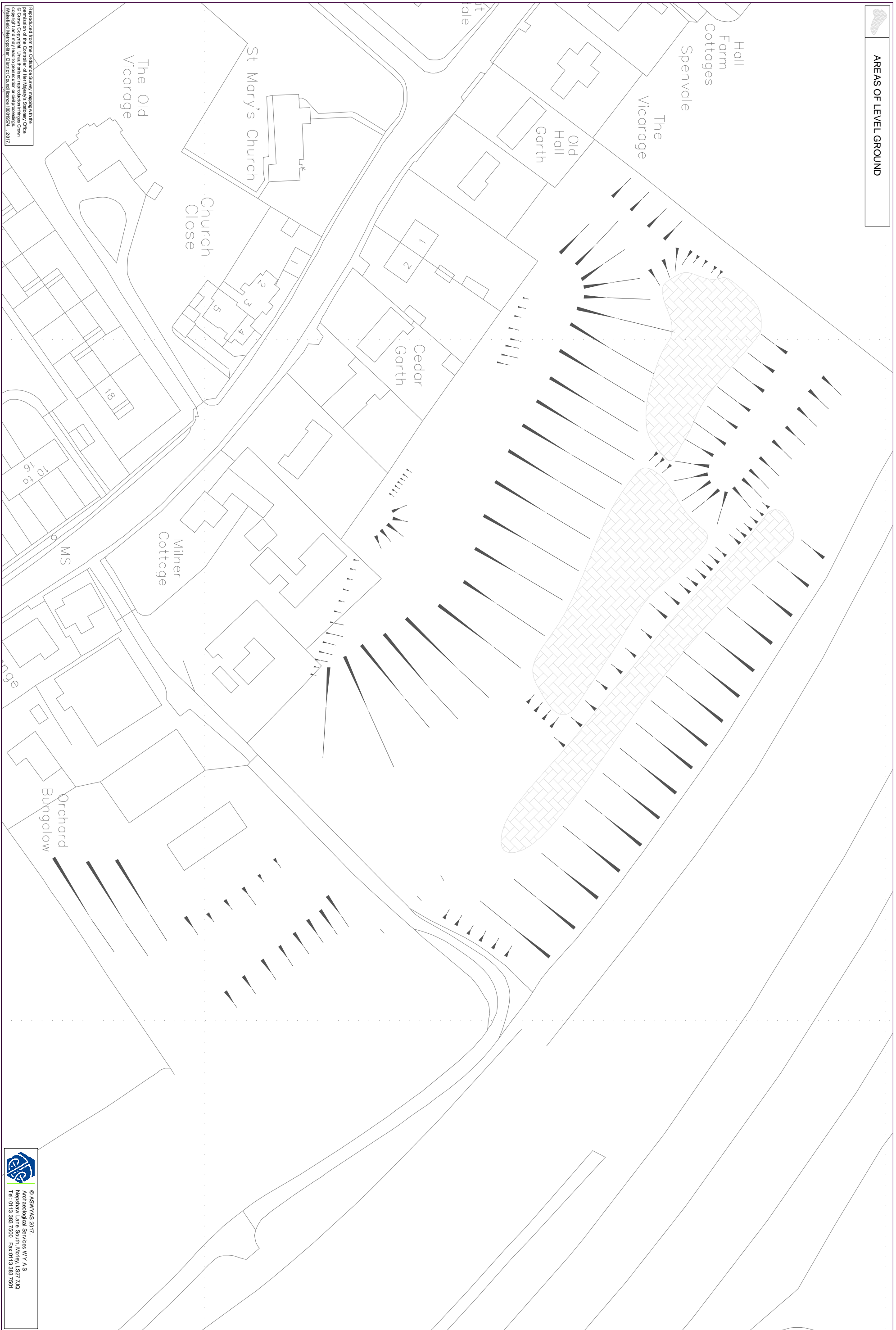

N  
433800

433600

444200

444400

0 50m

Redrafted from the Ordnance Survey map with the permission of the Ordnance Survey. All rights reserved. © Crown Copyright. Unauthorised reproduction is prohibited. Ordnance Survey is a registered trademark of Ordnance Survey Limited. Ordnance Survey is a registered trademark of Ordnance Survey Limited. Ordnance Survey is a registered trademark of Ordnance Survey Limited.

© ASWYAS 2017  
 100, Weymouth Road, Weymouth, Dorset, DT9 7JG  
 Tel: 01328 7500 Fax: 01328 7501

Fig. 13. Earthwork survey (1:1000 @ A3)